

Precise Measurement Of Material Throughput

Engineered as part of the Conair TrueWeigh™ Gravimetric Extrusion Control System, the TrueWeigh hopper measures the mass flow of material into the extrusion process and sends this loss-in-weight information to the TrueWeigh controller. The controller then accurately monitors or adjusts the extruder screw RPM and/or haul-off RPM to maintain a consistent yield control. This enables an operator to run a uniform product within the tightest tolerances at the lowest possible cost.



Model TWH-27

Accurately Measures Extruder Rate by Weight

Mounting directly to the extruder throat, the TrueWeigh™ hopper includes the weigh electronics and load cell required to precisely measure the extruder's material throughput. The "floating" weigh hopper is cantilevered off the load cell and is contained within a heavy-duty frame.

Three (3) hopper sizes are available for throughput rates from 10 to 5,000 lbs/hr {4.5 to 2268 kg/hr}. The hoppers include a 60 degree bottom cone for constant plug flow to optimize blend integrity through the weigh hopper. The steep wall hopper works well with any combination of free-flowing pellet, flake, regrind and free-flowing powder or granular materials. A clear polycarbonate inspection/clean-out door or sight glass allows at-a-glance visual inspection of the hopper contents.

▶ Ease of installation

TrueWeigh™ hoppers are supplied with sub-plates for direct connection to the extruder feed throat. Supplied as a blank, the sub-plate eliminates the need for feed throat detailing prior to installation. Simply measure and drill the matching feed throat bolt pattern, fasten the sub-plate in place and mount the hopper. No additional support is needed. Optional custom mounting adapters are also available.

▶ Integral loading support platform

TrueWeigh standard loading options accommodate Conair positive slide gates with vacuum receivers, surge hoppers, stub, or blending systems. Custom adapters are available to accommodate non-Conair loading equipment.

▶ TrueBlend integration

The TrueWeigh hopper can be used in conjunction with a TrueBlend Gravimetric Batch Blending System. The largest hopper can support up to a TB900 with loaders with no additional support required.



Specifications

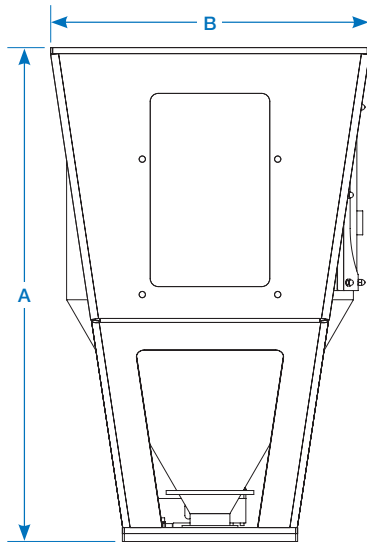

Side view

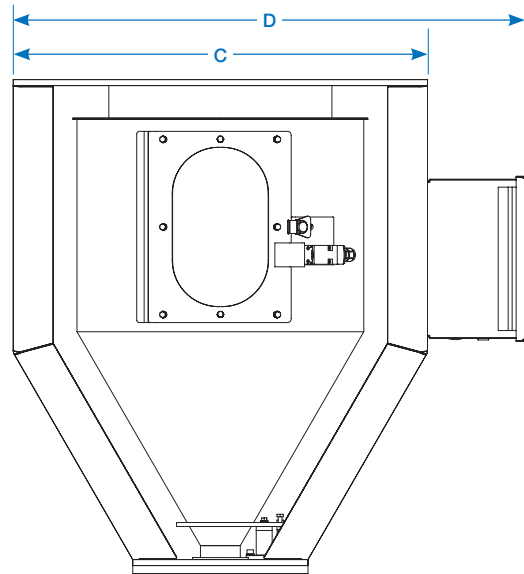

Front view

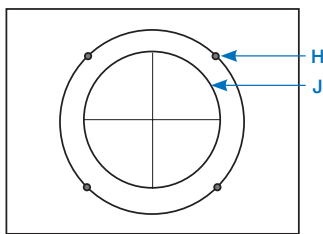

Top plate

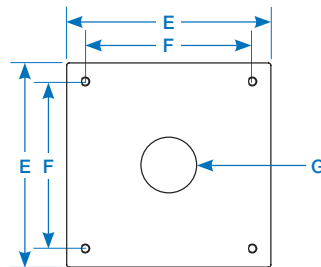

Bottom plate

Note: Standard plate is supplied blank

Model	TWH-05	TWH-27	TWH-44
Performance characteristics			
Hopper capacity ft ³ {}	0.5 {14}	2.7 {76}	4.4 {125}
Dimensions inches {mm}			
A - Height	18.50 {469.9}	30.50 {774.7}	42.00 {1066.8}
B - Depth	12.00 {340.8}	20.00 {508}	
C - Hopper width	18.00 {457.2}	26.00 {660.4}	28.00 {711.2}
D - Overall width	23.91 {607.36}	32.12 {815.9}	34.12 {866.7}
E - Mounting plate width	10.16 {257.96}	11.00 {279.4}	13.00 {330.2}
F - Hole diameter	8.00 {203.2}	9.00 {228.6}	11.00 {279.4}
G - Hole diameter	2.56 {65.07}	3.00 {76.2}	3.50 {88.9}
H - Hole diameter	0.38 {9.53}	0.42 {10.54}	
J - Hole diameter	7.00 {177.8}	12.25 {311.15}	
Approximate weight lb {kg}			
Shipping	75 {34}	125 {57}	250 {114}
Extruder size inches {mm}			
Minimum	2.5 {63.5}	3.0 {76.2}	3.5 {88.9}
Maximum	4.5 {114.3}	6.0 {152.4}	8.0 {203.2}

Specification Notes

Specifications may change without notice. Please consult a Conair representative for the most current information.

Features

- Mild steel construction
- High accuracy, precision cantilever load cell
- High resolution weighing electronics
- Integral loader/surge hopper support platform for Conair equipment
- Inspection sight glass (on TWH-05)
- Clear polycarbonate inspection cleanout door (on TWH-27 and TWH-44)
- Dust seals
- Extruder mounting sub-plate (drilled in the field)

Options

- Stainless steel construction
- High temperature design (up to 350° F {177° C})
- Dry air purge ports
- Dust tight seals
- Drain valve (on TWH-27 and TWH-44)
- Positive shut-off valve on inlet
- Custom mounting adapter
- Integration with TrueBlend Blender for mono-extrusion line control
- Special paint

