

Safely Directs Materials to Conveyor Feed Tubes

Conair Tilters provide a safe method of moving free-flowing materials to one corner of a shipping container for complete emptying by a vacuum loader. They are built tough to withstand heavy use on production floors.

The tilters can be used beside your processing machines or in remote central material storage rooms to assure a constant flow of material throughout your plant. Once emptied, simple foot- or hand-operated controls level the container for removal and replacement.



120 Series Raised Platform Tilter

Floor Level Or Raised Platform Models

Gaylord tilters are available for holding containers weighing up to 3,000 lbs.

Floor level tilters are either hand or foot operated and can hold containers up to 1500 lb. They can be set for either manual or automatic operation.

It can be easily loaded by a hand truck or pallet mover because the box platform is flat on the floor. A heavy-duty air bag device slowly fills with compressed air to automatically tilt the platform and container as it is emptied. An adjustable conveyor feed tube support is included.

Raised platform tilters are operated by heavy-duty air cylinders. This type of tilter is adjusted so that it will start lifting the container when less than 500 lbs remain in the box. Then it slowly tips the box to a 45° angle to assure smooth continuous feeding to the vacuum feed tube.

- ▶ **Wide capacity range**
Capacities for 1200 lb, 1500 lb and 3000 lb loads.
- ▶ **Prevent material voids**
Air or electric-operated vibrators are available to prevent material voids.
- ▶ **No electricity required**
Compressed air operated.
- ▶ **Automatic or manual operation**
Tilters can be set for either manual or automatic operation. The tilters will automatically swing up as material is emptied to assure a constant flow of material.



299 Series Floor Level Tilter



Specifications

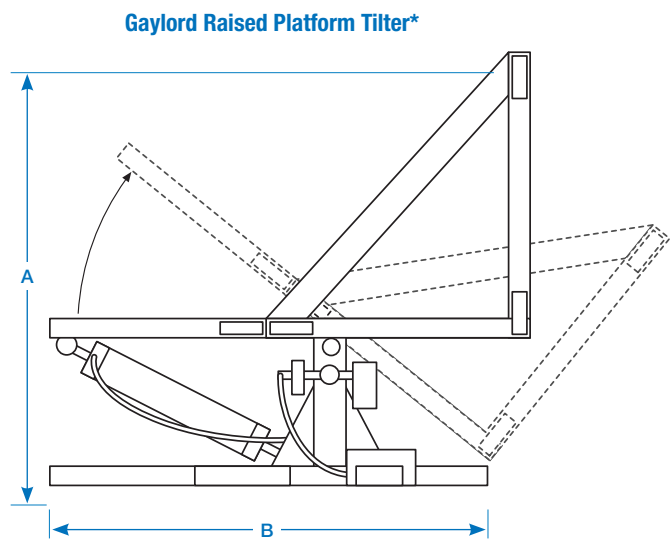
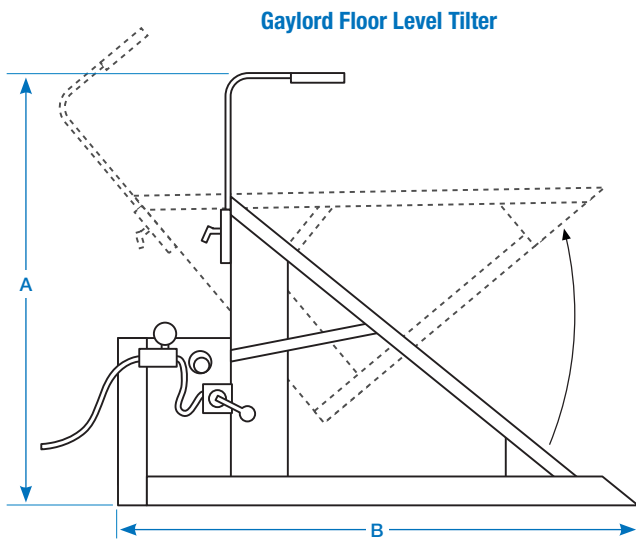

Models	299-276-01	299-276-02	120-004	120-005
Performance characteristics				
Capacity lb {kg}	2500 {1134}		1200 {544}	3000 {1361}
Tilter type	floor level		raised platform	
Control type	foot	hand	foot	
Dimensions inch {mm}				
A - Height †	36 {914}		46.5 {1181}	74 {1880}
B - Width	52 {1321}		40 {1016}	50 {1270}
Length	73 {1854}		40 {1016}	50 {1270}
Weight lb {kg}				
Shipping	450 {204}		540 {245}	1450 {658}
Compressed air requirement				
	40 psi @ 2 CFM {2.75 bars}		80 psi @ 2 CFM {5.52 bars}	

Specification Notes

* Allow a minimum of 30 inches on each side of tilter for working area.

† Height is 54 inches from the floor with wand holder fully extended.

Specifications may change without notice. Consult with a Conair representative for the most current information.

Options

- Electric or pneumatic vibration kits
- Full-tilt indicator light
- Safety check valve
- Gaylord cover

How it works

Raised Platform Tilters

Once placed so that containers can be loaded and removed from the platform, the air regulator is connected to a compressed air supply and a full container is placed on the platform with a hand truck. When the container is about half empty, the operator opens the air flow, inflating a heavy-duty air bag which tilts the platform. The correct adjustment is made when the tilter begins to lift the container. This becomes the correct setting for all future containers of that weight. The hand or foot control remains on at this point and the platform will continue to tilt automatically as material is removed from the container. The tilter can also be manually operated after the container is about half empty and can be leveled by the control for container changes.

Floor Level Tilters

Once these heavy-duty tilters are placed on a level floor and connected to an appropriate compressed air source, a full container is placed in the platform by a lift truck.

An air regulator and air filter are provided to operate the air cylinder which tilts the platform. Once the container is about half empty, air pressure is adjusted to start lifting the platform. From this point on tilting is automatic. As material is emptied, the platform continues to tilt. The larger model 120-005 is designed for extra heavy container tilting. Again, about half the material should be emptied before setting the tilt air pressure. Once the model tilts past the counterbalance point, a cam shuts the air off to the cylinder to maintain safe movement.

