

USERGUIDE

IMA-072-C1

12/85

Conomix Plus

TABLE OF CONTENTS

Chapter 1	Introduction	
	Functional Description	6
	Applicable Materials	6
	The Blender Assembly	7
	Blender Specifications	8
	Blender Features	
	Interchangeable Auger/Sleeve Combinations	9
	Calibration Sample Chute	10
	Hopper Clean-Out Door	11
	Removable Mixing Chamber	12
Chapter 2	Installation	
	Machine Mounting	14
	Central Blending Mounting	14
	Control Box Mounting/Electrical	16
	Loader Installation	16
	Mounting	16
	Wiring	16
	Air Requirements	16
Chapter 3	Blender Set Up	
	Auxiliary Alarm Hook-Up	19
	Level Sensor Adjustment	19
	Selecting Auger Sizes	20
	Auger/Sleeve Removal and Replacement	21
Chapter 4	Control Panel	
	Layout	23
	Functions	24

TABLE OF CONTENTS

Chapter 5 Control Operation and Set Up

Start-Up	27
Operating The Control	28
Select (Main) Menu	28
Selecting A Recipe - Menu Pos. 0	29
Creating/Editing A Recipe - Menu Pos. 1 through 4	29
Monitoring Blender Performance	
Totalizer - Menu Position 5	30
Hopper Levels - Menu Position 6	31
% Total Throughput - Menu Position 7	31
Diagnostics - Menu Position 8	32

Chapter 6 Diagnostics Menu and Functions

Diagnostics Menu Listing	34
Using Diagnostic Functions	35
Function Summaries And Uses	35

Chapter 7 Blender Calibration

Volumetric Calibration - Access Code 754	54
Calibration Stop Mode - Access Code 755	59
Edit Calibration Data - Access Code 756	60
Hopper Clean-Out - Access Code 757	62
Calibration Data Log	63

Chapter 8 Blender Operation

Review Of Start Up-Procedures	65
Accuracy And Taking Material Samples	66

TABLE OF CONTENTS

Chapter 9	Troubleshooting	
	<SETUP> Mode	70
	<SETUP> Diagnostics Menu Listing	71
	Using <SETUP> Diagnostic Functions	73
	<SETUP> Diagnostics Function Summaries	75
	Alarms And Possible Causes	84
	Circuit Board LED Identification	86
Chapter 10	Appendix	88
	Warranty/Service Information	
	Parts List	
	Control Box Assembly	
	Control Box Wiring Diagram	
	Terminal Box	
	Terminal Box Wiring Diagram	
	Sample RS-232 Print-Out	

INTRODUCTION

Functional Description

Applicable Materials

The Blender Assembly

Blender Specifications

Blender Features

- Auger/Sleeve Combinations
- Calibration/Sample Chute
- Hopper Clean Out Door
- Removable Molding Chamber

FUNCTIONAL DESCRIPTION

The Conomix Plus is a microprocessor controlled, CIM compatible, four-component Volumetric Blender designed for at-the-throat or central material blending. This blender is extremely easy to set up and offers reliable inventory management while accurately maintaining your material blend.

Conomix Plus features include:

An easy-to-operate control with a 2x20 character display that guides the operator through all the blending functions.

Continuous blending...Unlike batch-type blenders, the Conomix Plus automatically adjusts the throughput of all ingredients to match and maintain the rate of material usage.

Material Usage Totals...The Conomix Plus makes inventory control simple and reliable by providing a running total of material usage for each ingredient as well as the total blender throughput.

APPLICABLE MATERIALS

1. Powders (PVC, PP, PE, ABS)
2. Granular (LLDPE)
3. Pelletized Resins
4. Regrinds
5. Fillers (talc, mica, calcium, carbonate, Wollastonite)
6. Additives (Pelletized/free flowing powders)
 - a. Color concentrate (no dry color)
 - b. Fire retardants
 - c. U/V inhibitors
 - d. Stabilizers
 - e. Processing/Flow Aids

BLENDER FEATURES (CONT.)**Removable Mixing Chamber** - See Figure 5

1. Disconnect power to mixer motor.
2. Remove small lower band clamp (A)
3. Tighten two thumb screws (B) - this will lower the seal plate (C)
4. Aluminum cast slide gate (D) can now be removed.
5. Remove large upper band clamp.
6. Lower the mixing chamber to allow access to the agitator.
7. Turn agitator counter-clockwise (as loosening a bolt)
8. Remove agitator and then mixing chamber.

To assemble, reverse above procedure.

CAUTION: NEVER open the mixing chamber door without first pushing the Mixer Motor rocker switch on the Blender Control Box to the "OFF" position.

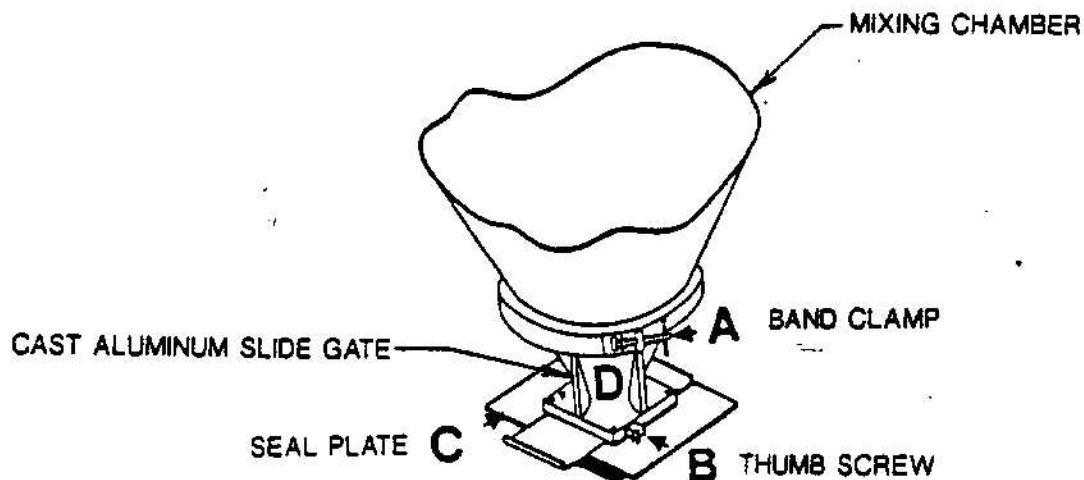

Figure 5 - Mixing Chamber Bottom Removal

BLENDER FEATURES (cont.)**Hopper Clean-Out Door**

Before opening the supply hopper clean-out doors, check that the Power and Mixer Motor On/Off Rocker Switches are in the OFF position, and that the power is disconnected from the control box. As a safety feature, there is a magnetic interlock for each clean out door which prevents the blender from running when any door is open.

If a door is open while the control is "ON", the control will alarm "Interlock Open".

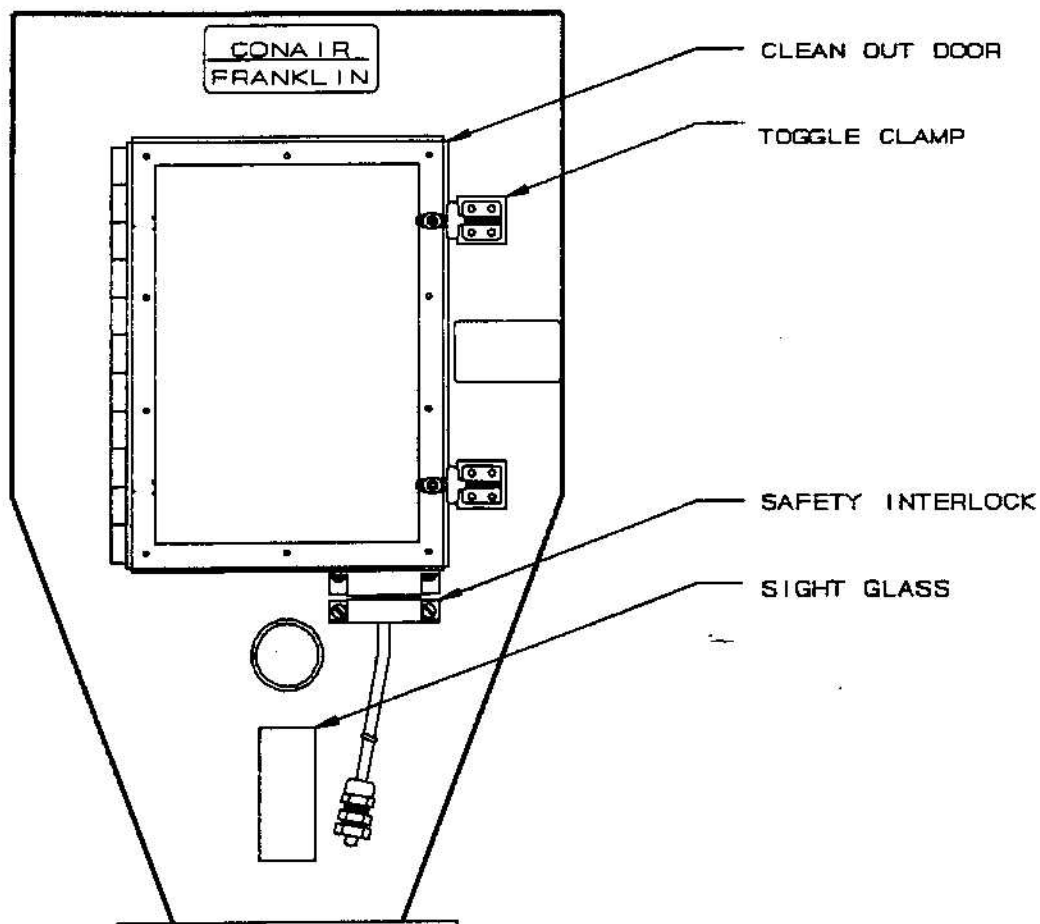

Figure 4 - HOPPER CLEAN-OUT DOOR

BLENDER FEATURES (cont.)

The Calibration Sample Chute

Each auger housing on your blender is equipped with an internal calibration slide gate that can be used to divert your auger fed material away from the mixing chamber and to the calibration sample chute.

The calibration slide gate is used when performing a volumetric calibration of each auger position needed for a recipe. During the calibration, materials metered through the calibration sample chute are individually collected by the operator to be weighed, then returned to the storage containers for later use.

The calibration slide gate has two functional positions, both shown in Figure 3.

The RUN POSITION allows material to fall directly from the auger into the mixing chamber. Select the Run Position by pulling the slide gate tabs until it reaches its fully downward position.

The CALIBRATE POSITION diverts material away from the mixing chamber and through the calibration sample chute. Select the Calibrate Position by pushing the slide gate tabs until it reaches its fully upward position.

NOTE: If your blender is equipped with plastic plugs in the calibration sample ports, you must remove them before running the blender with the calibration slide gate in the Calibrate Position.

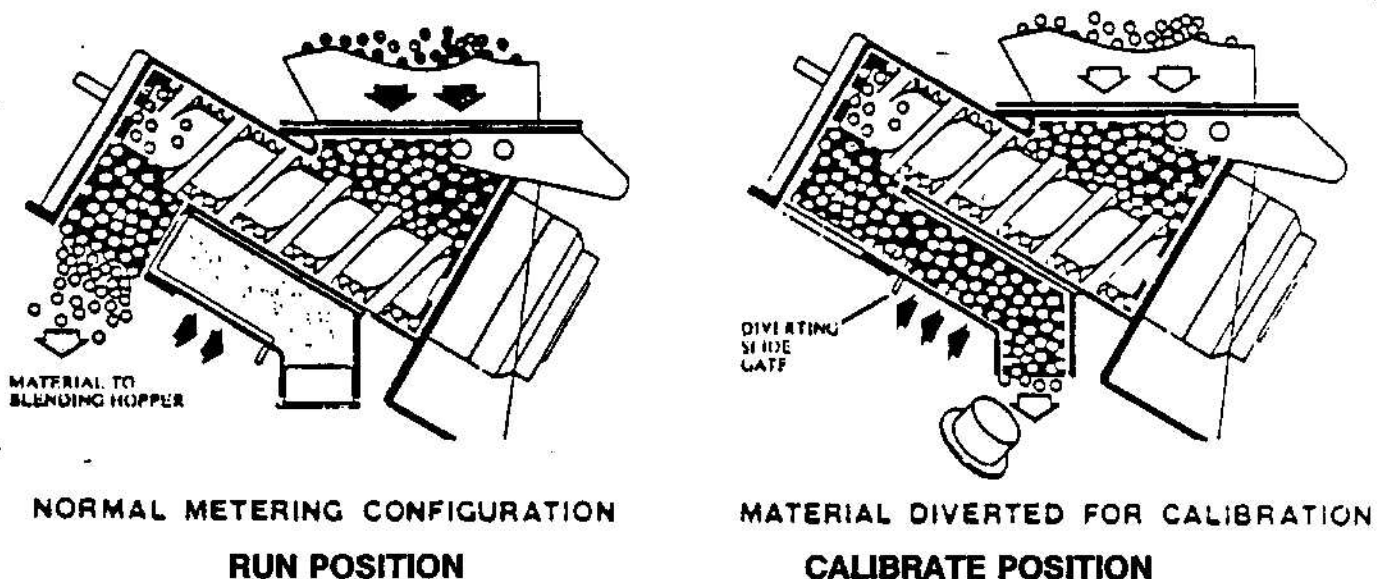

Figure 3 - CALIBRATION DIVERTER CHUTE

BLENDER FEATURES

The Conomix Plus is designed to allow for easy setup as well as easy cleaning and maintenance. The following are some of the convenient standard features you'll find built into this blender.

Interchangeable Auger/Sleeve Combinations

Auger/Sleeve Combinations are located in the auger housings (See Figure 2).

The sleeve slides into the auger housing from the bearing cap end and is locked into position by tightening the thumbscrew located on the side of the auger housing.

The auger is installed through the sleeve center bore and should engage the drive coupling at the end of the auger housing.

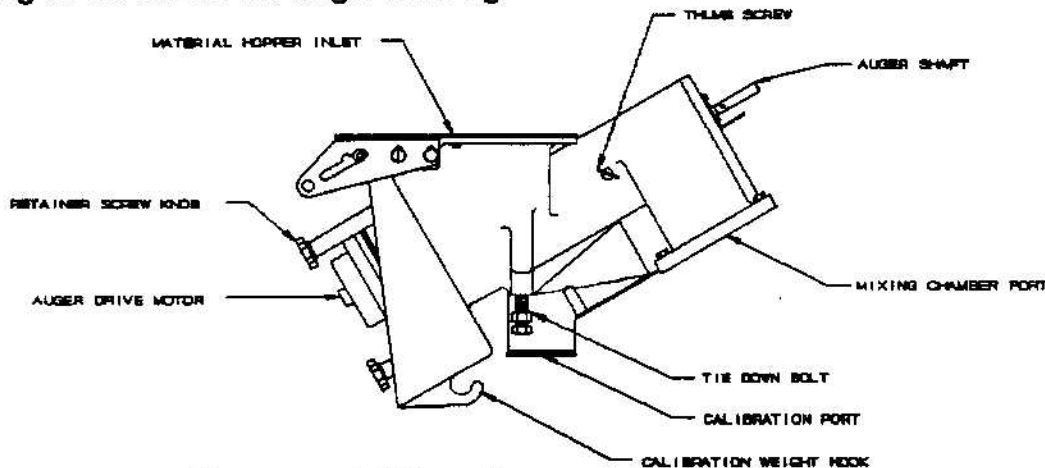

Figure 2 - AUGER HOUSING

Each auger should be installed with a properly sized sleeve. As a general rule of thumb,
 PELLETS require a 3/8" clearance
 POWDERS require a 1/8" clearance
 where CLEARANCE is measured as (sleeve ID) minus (auger OD).

Auger sizes vary to cover a wide range of throughput rates. See *Chapter 3 - Selecting Auger Sizes* for available auger sizes and their maximum rates.

For proper removal and installation procedures, please see *Chapter 3 - Auger/Sleeve Removal and Replacement*.

BLENDER SPECIFICATIONS

Voltage:	120 VAC, Single Phase supply @ 15 Amps
Mixer Motor:	1/2 HP TEFC, 120 VAC, 1 ϕ , 7.8 Full Load Amps, 1750 RPM
Mixer Gear Reducer:	35:1 Ratio, 50 RPM Output
Metering Auger Motors:	0-24 VDC, 45 Watts, 2.8 Amps, 25: 1 Ratio 0-120 RPM Output
Supply Hopper Capacity:	2 cu ft (Std.), 3 cu ft (Opt.)
Mixing Chamber Capacity:	1.5 cu ft
Shipping Weight:	500 Lbs.
Compressed Air Supply:	80 PSI (We suggest using a minimum 3/4" pipe supply line with 3/8" ID flexible hose to individual connections)

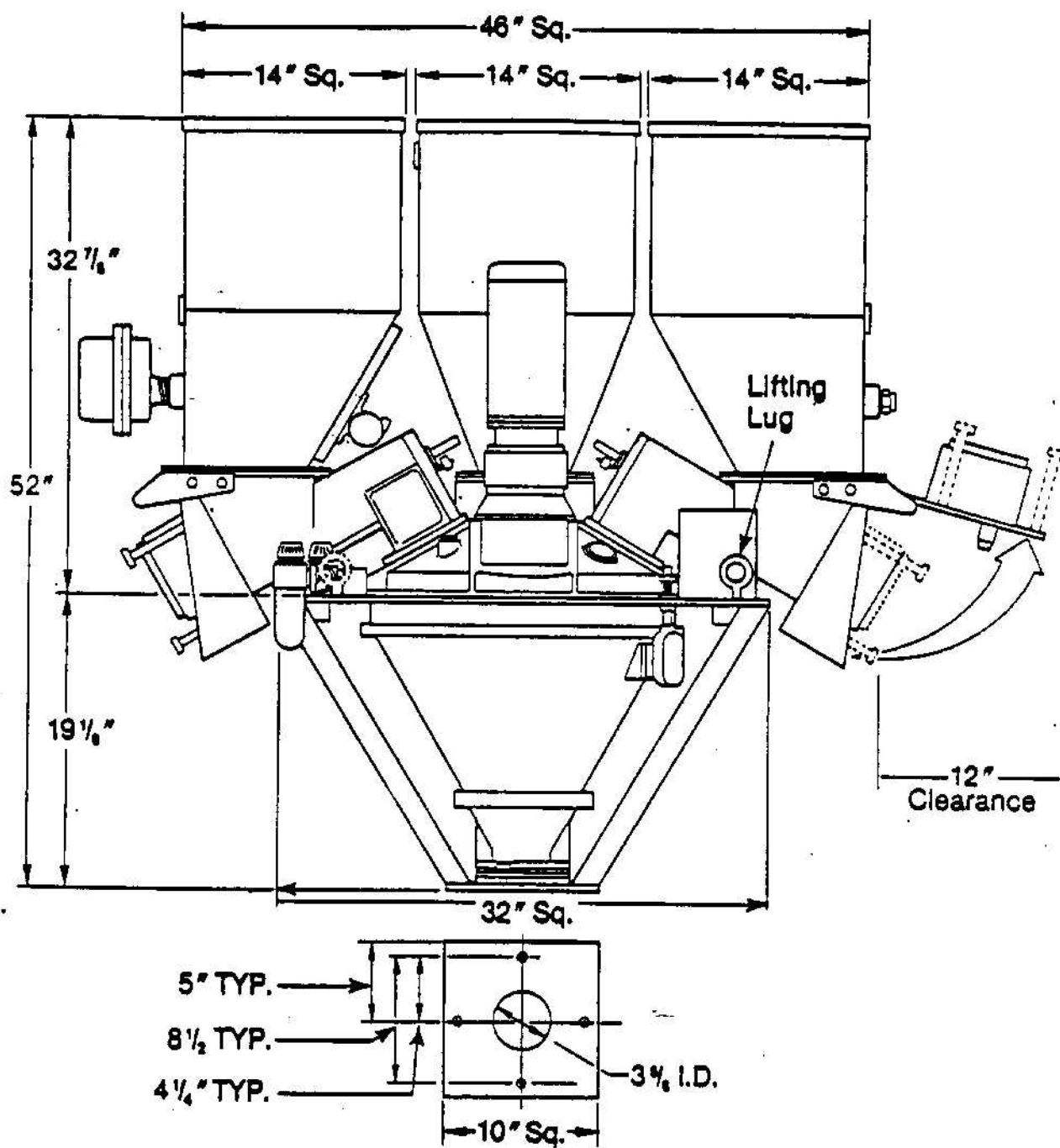

Figure 1 - THE BLENDER ASSEMBLY

INSTALLATION

Machine Mounting

Central Blending Mounting

Control Box Mounting/Electrical

Loader Installation

-Mounting

-Wiring

-Air Requirements

This section will describe the installation procedure for the blender as well as for its integral parts.

MACHINING MOUNTING

This blender is designed for mounting directly to the throat of the injection molding machine or extruder. The mounting plate has four holes for 3/8 - 16 NC flat head countersunk bolts. An adapter plate with holes matching the blender and your processing machine should be fabricated. This plate should be .625 thick or greater and should be bolted to the machine throat before mounting the blender. The blender mounting plate bolt hole pattern is square, so the blender can be rotated as needed to position the mixing chamber drain port to the desired location.

Lifting straps may be used to lower the blender onto the processing machine. Be sure to avoid wires and hoses when slinging the blender for movement. Use the lower section of the metering housings as a grip point for the straps.

If extreme machine vibration or screw break action occurs in your process, it may be necessary to stabilize the blender with auxiliary bracing. You, the customer, are responsible for the integrity of the final installation.

CENTRAL BLENDING MOUNTING - See Figure 6

For central blending applications, the blender is mounted on a fill stand or surge bin. To provide for adequate residence time within the mixing chamber, the blended material is metered from the blender through a discharge auger bolted between the receiving bin or stand and the blender. The location of the bin or gaylord fill stand should be central to your operation and provide optimum access for lift truck traffic (gaylord fill) or piping from the distribution box (surge bin).

When installing the system, first bolt the discharge auger assembly to the surge bin or fill stand. Then mount the blender directly to the discharge auger assembly. A matching bolt pattern is provided and no adapter plate is necessary. Be sure to carefully consider the orientation of all components for operation, cleanout, and service.

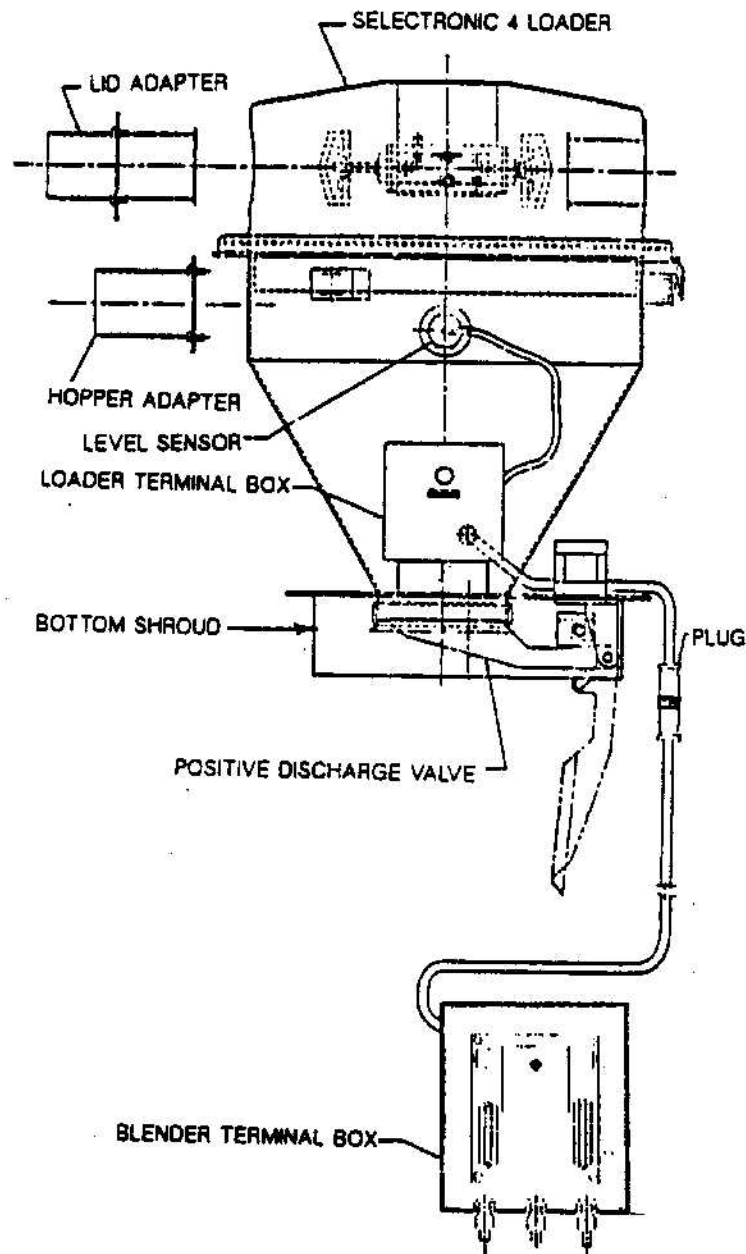

Figure 7 - LOADER

CONTROL BOX MOUNTING/ELECTRICAL

120 Volt/Single Phase/15 Amp grounded service is required. Be sure to follow all local and national electrical codes.

MACHINE MOUNTING - Mount the main control on the vibration-free surface at machine operator level. (Mounting the control on an injection machine or extruder is not recommended.) Fifteen feet of cable is provided with an amphenol connector on the control box. Circuit protection is provided in the main control enclosure in the two illuminated power switches labeled "Power On/Off" (15 amp), and "Mixer Motor On/Off" (12 amp).

CENTRAL BLENDING - Mount the additional discharge auger control on a vibration-free surface within the 20-foot length of cables supplied with the discharge auger and binicator(s). Close proximity to the main blender control is recommended.

LOADER INSTALLATION See Figure 7

Automatic Conveying Equipment can be used to convey and load pelletized materials, regrinds, and powders to the blender supply bins.

The blender control can operate two types of loaders: Selectronic and Integral Motor. The Selectronic loaders require a common vacuum source which can also be controlled by the blender.

MOUNTING - The loaders have a mounting flange that bolts to the loader mounting plate on the top of the blender frame. The loader should be oriented to allow for easy routing of the material lines. We strongly suggest using a flexible connection for the material and vacuum lines for ease of maintenance.

WIRING - The interconnecting wiring is accomplished easily through the blender's quick disconnect electrical fittings that mate to the loader's pre-wired terminal boxes, and a terminal strip in the blender control to signal the pump and dust collector.

AIR REQUIREMENTS - The air required (80 PSI) can be dropped to any one of the loaders' solenoid valves (located on the loader terminal boxes) then routed to the other loaders on the blender.

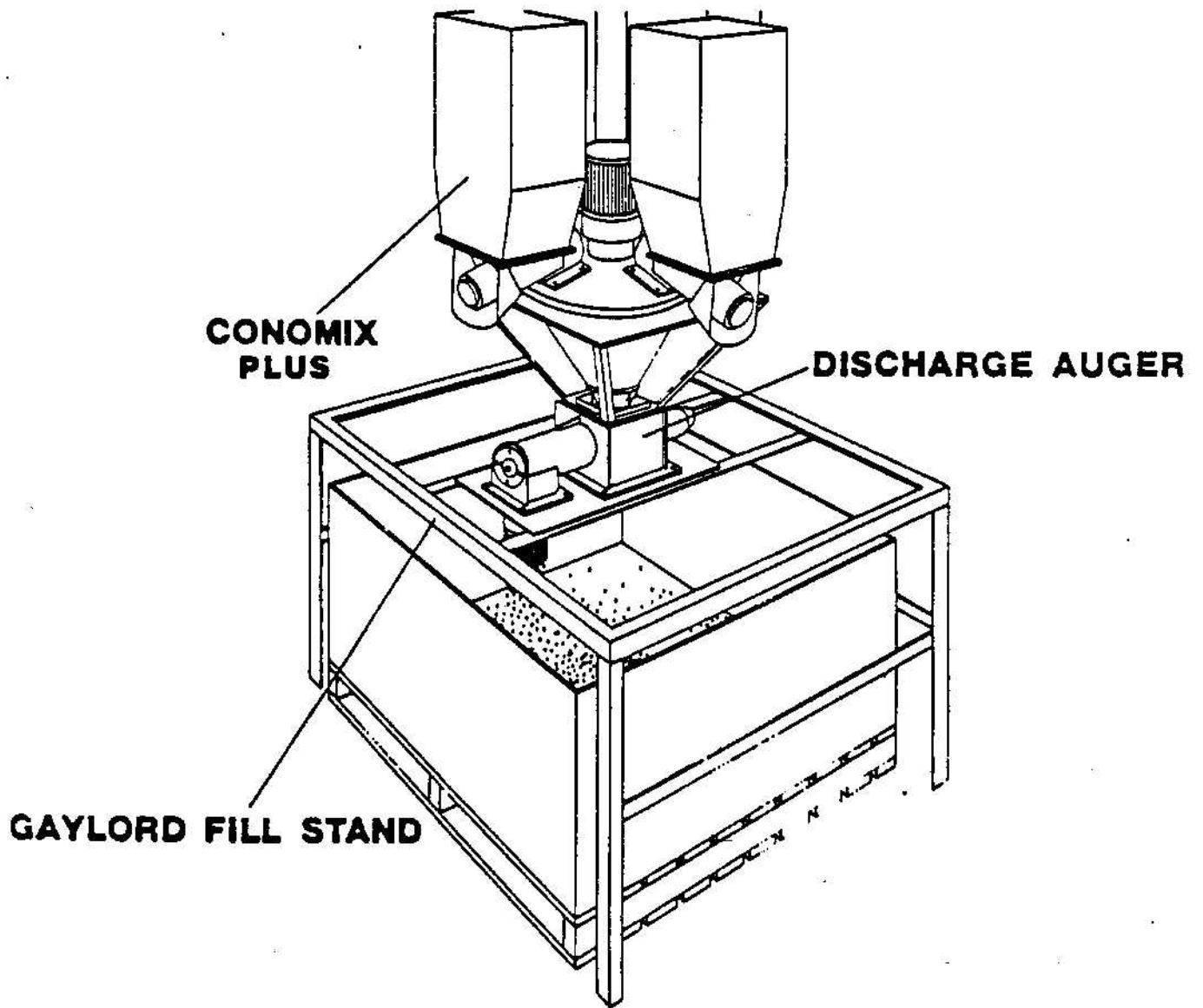

Figure 6 - Central Blending Application

BLENDER SETUP

**Auxiliary Alarm Hook-Up
Level Sensor Adjustment
Selecting Auger Sizes
Auger/Sleeve Removal
and Replacement**

AUXILIARY ALARM HOOK-UP

In addition to the audible and visual alarm signals provided with the Control Box, all Conomix Plus blenders are equipped with 115 VAC triac driven auxiliary alarm output for driving an external warning light, horn, or siren. The external alarm can be wired to the blender control box as follows:

<u>Terminal #</u>	<u>Description</u>
22	Alarm Signal (115 VAC)
2	Neutral
G	Earth Ground

NOTE: Alarm output is rated at 0.25 Amps maximum.

LEVEL SENSOR ADJUSTMENT (See Figure 8)

The blender mixing chamber can contain up to two capacitive proximity sensors located in the mixer top plate. These sensor(s) provide signals that enable the blender control to maintain a full level of material in the mixing chamber, independently of time or rate.

Before running any material through the mixing chamber:

1. Check the sensor's mounting and position - The mixer sensor(s) should be positioned so that its top is flush with its cast mounting hole as shown in FIGURE 7.
2. Adjust the sensor's sensitivity - Turn the trimpot clockwise until the LED energizes. Slowly turn the trimpot counter-clockwise until the LED de-energizes. Turn the trimpot an additional 1/2 turn counterclockwise. Be sure to adjust both mixing chamber sensors.
3. Check the adjustment - To check the sensor adjustment, first hold your hand approximately 1/2" from the sensor tip and the LED should energize. Next, reinstall the mixing chamber door and turn the mixer motor on to make certain the sensor is not energized by the rotating agitator.

AUGER/SLEEVE REMOVAL AND REPLACEMENT - See Figure 9

1. Remove material from supply hopper as follows:
 - Set container/drum under drain spout below metering motor
 - Loosen the three motor plate mounting knobs
 - **Hold exposed auger shaft at upper end by knurled grip**
 - Pull auger drive motor out from auger
 - Swing motor up and lock in position (A)
 - Remove auger (B)
2. **Before removing the sleeve**, carefully wipe the inside of the auger housing to remove any pellets remaining from emptying the hopper. This prevents material from becoming wedged between the auger housing and sleeve and trapping the sleeve inside the auger housing.
3. Loosen set screw on side of cast housing (C)
4. Slide out aluminum sleeve (D). Clean auger housing thoroughly.
5. Install new sleeve and tighten thumbscrew.
6. Insert auger (knurled end) through bushing in upper end of auger housing as far as possible. Drive end of shaft should point toward motor (E).
7. Swing motor mounting plate down and fasten in place.
8. Grasping the knurled end of the auger shaft, rotate and push until the auger drive tabs are seated in the motor drive ball coupling.

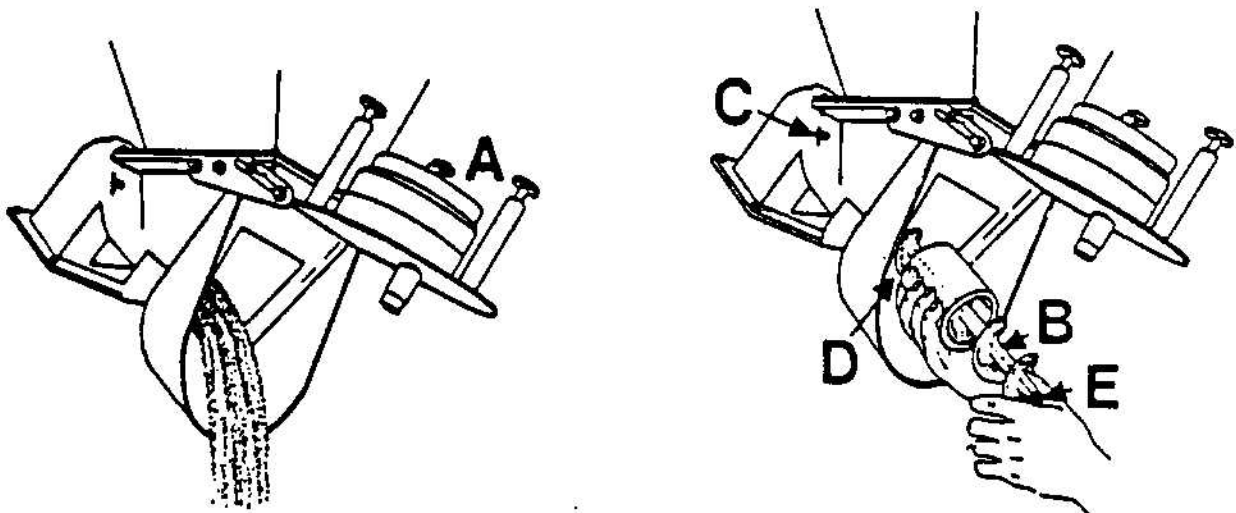

Figure 9 - Auger Sleeve Removal

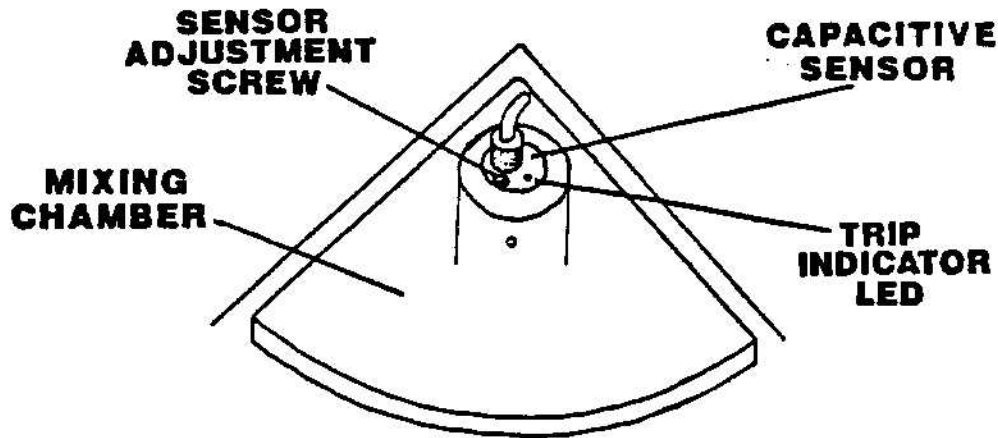

Figure 8 - THE MIXER LEVEL SENSOR

SELECTING AUGER SIZES

The smallest augers capable of maintaining the maximum expected rate of material usage for the given recipe should be selected. TABLE 1 lists the maximum throughput rates of all standard augers. In most cases, the augers supplied have been sized at CONAIR to maintain the application specified by our customer. For highest accuracy, an auger should be sized to maintain a minimum of 20% motor speed.

TABLE 1 - METERING AUGERS

SIZE	RATE (#/hr) BASED ON AUGER SPEED = 120 RPM BULK DENSITY = 35 #/CuFt
1/2"OD x 1/2"PITCH	7.5 #/hr
3/4"OD x 3/4"PITCH	29 #/hr
1"OD x 1"PITCH	72 #/hr
1-1/2"OD x 1-1/2"PITCH	266 #/hr
2"OD x 2"PITCH	644 #/hr
2-1/2"OD x 2-1/2"PITCH	1275#/hr
3"OD x 3"PITCH	2662 #/hr
<p>NOTE:</p> <ol style="list-style-type: none"> 1. All augers are stainless steel with welded flighting. 2. Each auger should be installed with a sleeve whose ID is 1/8" to 3/8" larger than the auger's OD. (1/8" clearance is for powders; 3/8" clearance is for pellets and regrind) 	

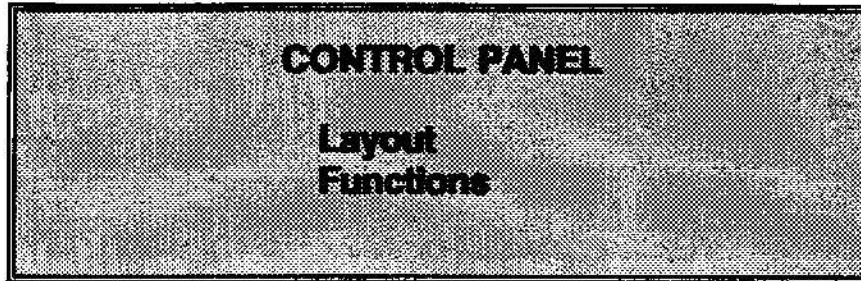

Control Layout

Please see CONTROL FUNCTIONS section for an explanation of the panel layout.

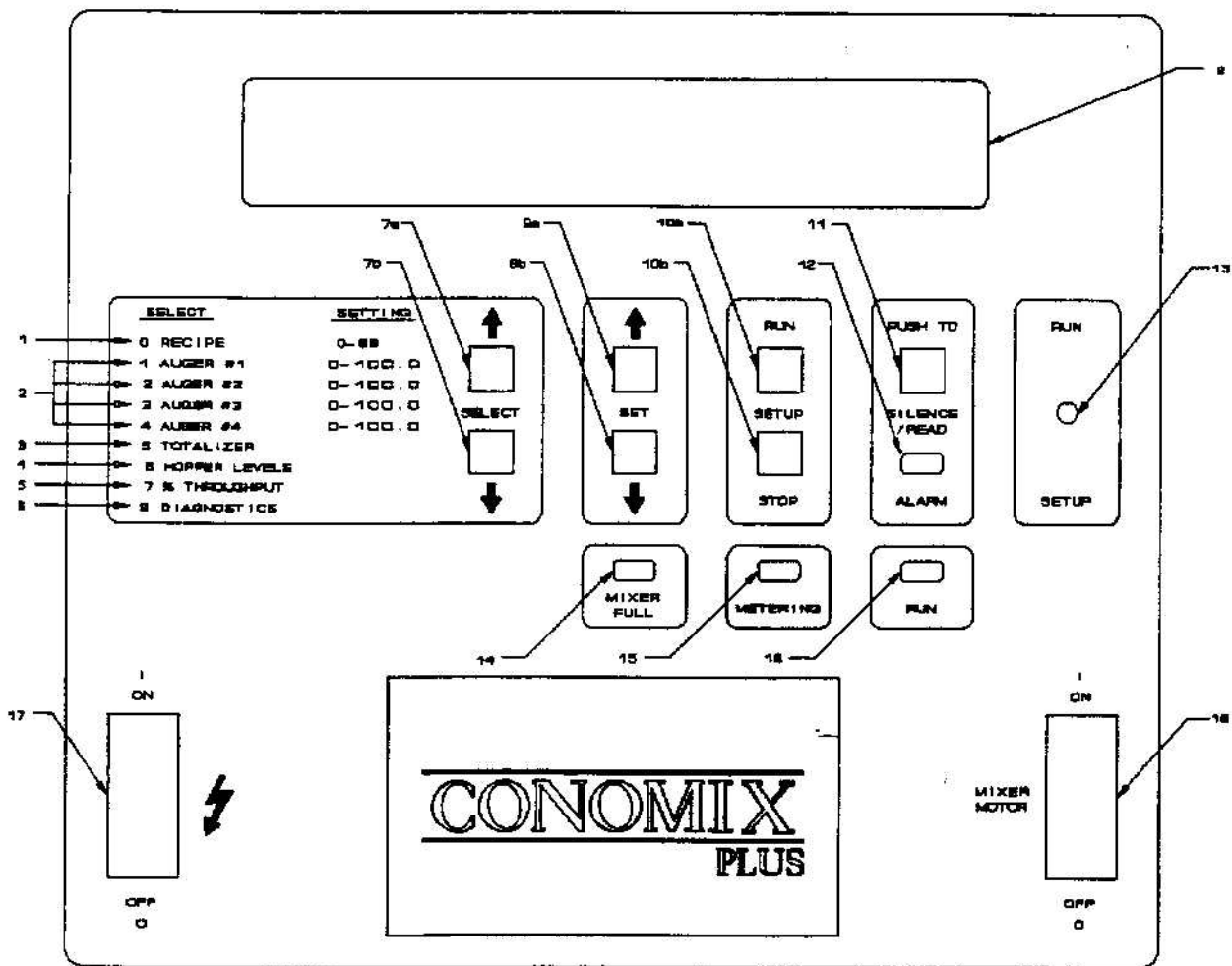

Figure 10 - Control Layout

Diagnostics

Advance to the last Position of the Select Menu using the DnSELECT Button (7B). The display will read:

Menu Pos. 8 - Diagnostics

DIAGNOSTICS	
Access Code	- 0

Access Code (0-999) permits entry to a corresponding diagnostic function

The DIAGNOSTICS functions allow the user to set all necessary operating parameters for the blender.

Before the blender first begins metering material, we recommend checking parameters available in the DIAGNOSTICS menu to ensure proper blender setup.

See Chapter 6 for a complete listing and functional description of the Diagnostics Menu.

NOTE: The Blender Control also has a <SETUP> DIAGNOSTICS screen with additional control functions useful for troubleshooting. Please see Chapter 9 for details.

Menu Pos. 6 - Hopper Levels

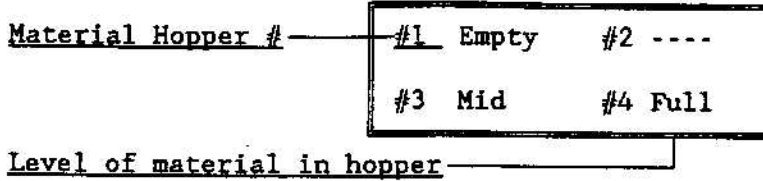

These descriptions will change during operation as the hopper material is continually metered out and then refilled.

Press the DnSELECT Button (7B) to proceed to the next Menu Position.

Menu Pos. 7 - % Total Throughput

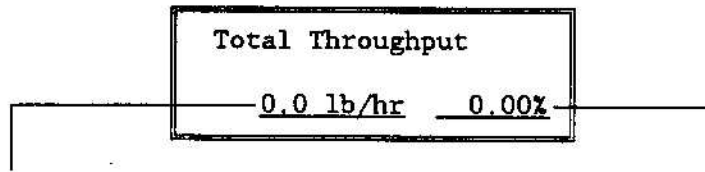

Total Lb/Hr metering through the blender, obtained by adding throughputs of auger positions 1, 2, 3 & 4.

Percent of maximum blender thruput capacity, based on the maximum throughput each auger position can achieve without affecting the blend proportions entered in the recipe.

Next, enter the setpoint for auger position 2. Press the DnSELECT Button and the display will read:

Menu Pos. 2 - Auger 2

2	AUGER #2	000.000
SP	0.0	RPM 0.0%

Continue to press the DnSELECT Button (7A) to advance through Auger Position 4, stopping at each position to set the desired recipe.

Menu Pos. 4 - Auger 4

4	AUGER #4	000.000
SP	0.0	RPM 0.0%

For each Auger Position, change the Setpoint as required using the SET BUTTONS (9A, 9B).

Monitoring Blender Performance - Menu Positions 5 through 7

The following menu positions display updated parameters highlighting the blender's performance. These screens provide information and require no user interaction.

Now that the blend proportions have been entered as outlined in the previous section, proceed to the next Menu Position using the SELECT Buttons (7A and 7B).

Menu Pos. 5 - Totalizer

<u>Material/Hopper #</u>	1	777.77	2	7777
	3	77.77	4	0.00
<u>Lbs or Kg. of material used since last Totalizer reset</u>				

No setpoints can be changed in this position.

The totalizer records the total material metered by each auger position for each individual recipe in memory since that recipe's last totalizer reset.

Press the DnSELECT Button (7B) to proceed to the next Menu Position.

Selecting A Recipe - Menu Pos. 0

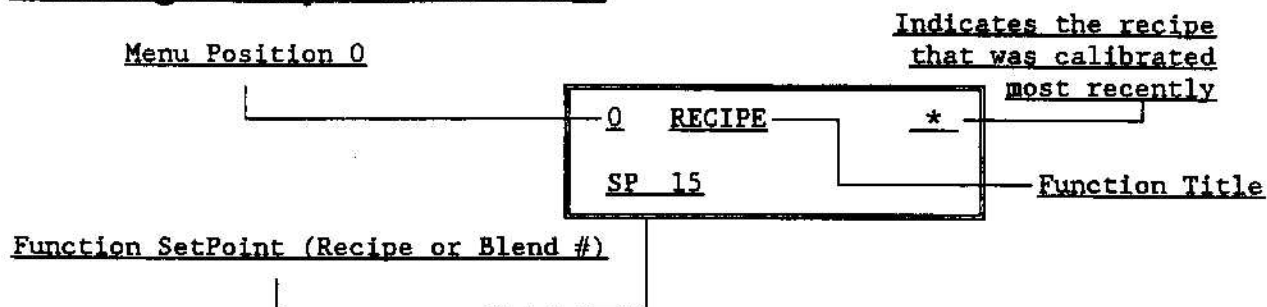

This function designates the recipe number. Any data entered on subsequent screens is automatically stored under the SetPoint you chose here.

Setpoint Range = 0 - 99: Each SP can contain a set of proportions for the 4 auger positions that are safely stored in the control's memory.

NOTE: When a recipe change includes a change in material or requires an auger change, please see "Editing Calibration Data" in Chapter 7.

Press the UpSET Button (9A) to increase the SP.
 Press the DnSET Button (9B) to decrease the SP.

Creating/Editing A Recipe - Menu Pos. 1 through 4

To CREATE, VIEW, or EDIT a recipe, select the desired SetPoint as shown above, then press the SELECT Buttons (7A and 7B) to advance through Select Menu positions 1 through 4.

Menu Pos. 1 - Auger 1

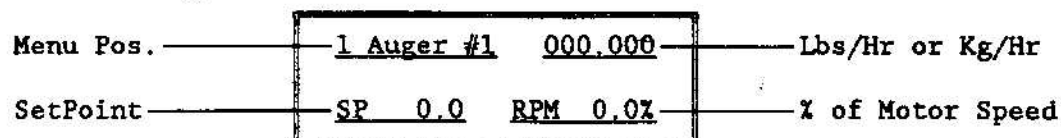

SP Range = 0.0 - 100.0 : SP represents the proportion of blend or mix; can be any unit of measure (parts, %, lbs, etc.) as long as the units are the same for all auger positions (1 - 4).

If this auger position is to be used, enter the correct setpoint using the SET BUTTONS (9A, 9B).

NOTE: S.P. = 0.0 will eliminate the auger position from the material blend by preventing the auger from metering material.

OPERATING THE CONTROL

Use the SET BUTTONS (9A and 9B) to change a SetPoint (SP).

UpSET increases the SP.
DnSET (down set) decreases the SP.

Please note that setpoints cannot be changed unless the RUN/SETUP switch (2) is in the SETUP position.

Use the SELECT Buttons (7A and 7B) to advance through the different Function Screens in the main program menu.

UpSELECT decreases Menu Position.
DnSELECT increases Menu Position.

SELECT (MAIN) MENU

<u>Menu Position</u>	<u>Function Title</u>	<u>Function Settings</u>
0	Recipe	S.P., 0 - 99
1	Auger #1	S.P., 0 - 100.0
2	Auger #2	S.P., 0 - 100.0
3	Auger #3	S.P., 0 - 100.0
4	Auger #4	S.P., 0 - 100.0
5	Totalizer	
6	Hopper Levels	
7	% Total Throughput	
8	Diagnostics	Access Code, 0 -999

Now that you are familiar with the control features and their locations, you must enter your process parameters for the blender to operate properly.

Please refer to the CONTROL LAYOUT Section in Chapter 4 for control panel references throughout this section and the remainder of the manual.

START-UP

Before turning the power on, the RUN/SETUP switch should be in the SETUP position. This prevents the augers from starting after initialization.

Once power is turned on, the unit should be allowed to warm up for at least 30 minutes if it has not been run for an extended length of time (more than one hour). This is especially true if the unit is to be calibrated.

Push the Power Switch to the ON position. The display will execute the following routine:

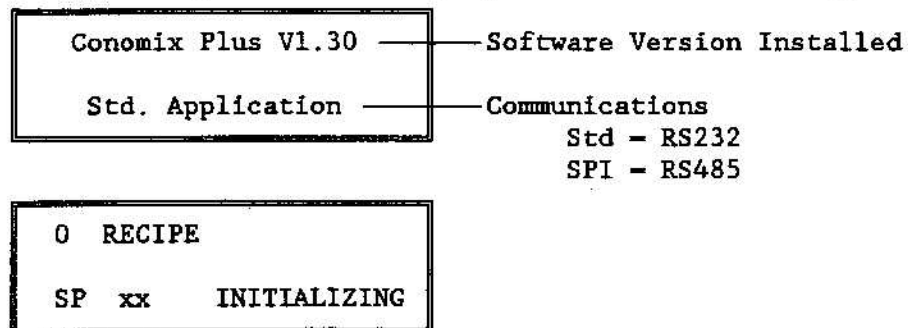

This is the control "loading itself from memory" which lasts approximately ten seconds. After the control completes initialization, the display will read:

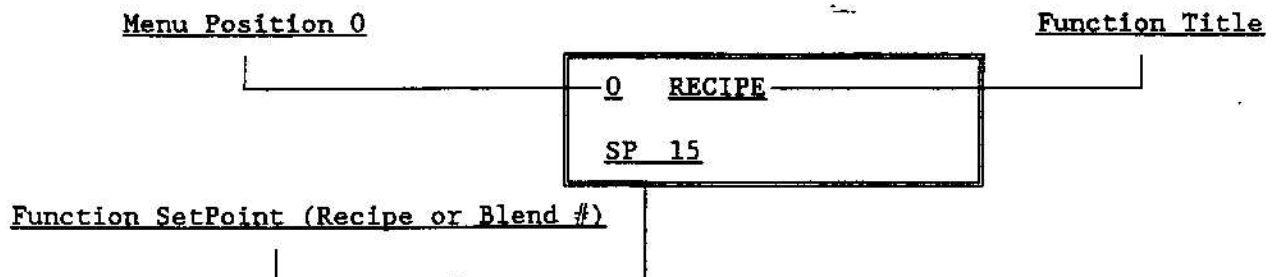

CONTROL OPERATION AND SETUP

Start-Up

Operating The Control

Select (Main) Menu

Selecting A Recipe

Creating/Editing A Recipe

Monitoring Blender Performance

-Totalizer

-Hopper Levels

-% Total Throughput

Diagnostics

13. Run/Setup Switch; sets the blender control mode to either the Setup (calibration) mode or the Run (operating) mode.
14. Mixer Full Light; indicates when the mixing chamber is full.
15. Metering Light; indicates operation of the metering cycle.
16. Run Light; indicates blender is in the Run mode.
17. On/Off Switch; combination switch and circuit breaker, 115 VAC control power. (See Wiring Diagram).
18. Mixer Motor Switch; combination switch and circuit breaker, 115 VAC mixer motor power. (See Wiring Diagram).

CONTROL FUNCTIONS

Listed below are explanations for each area of the control label (refer to Figure 10).

1. SELECT 0; indicates the recipe number from 0-99 and stores each recipe for access and repeatability without recalibrating. (When using same material but with different proportions; if material is changed, a new calibration must be performed or calibration data edited.)
2. SELECT 1 thru 4; indicates setpoint, lb./hr. & RPM of each auger. The setpoint is the proportion or % of each material.
3. Totalizer. SELECT 5; indicates the total, cumulative throughput of each auger for each recipe.
4. Hopper Levels. SELECT 6; indicates the on-hand material in each of the supply hoppers.
5. % Throughput. SELECT 7; indicates the % throughput of the total blended material with respect to maximum.
6. Diagnostics SELECT 8; for blender setup and calibration.
7. Select Buttons; select Up or Down the main program menu. Also used to access Diagnostic Screens.
8. Display Window; indicates user commands specified through the 'select' and 'set' buttons and prompts the user through the steps required for operation.
9. Set Buttons; for changing information in the display window and selecting the diagnostic screens.
10. Run/Stop Buttons; for control of the metering motors in the set-up mode.
11. Push-to-Silence/Read Alarm Button; for silencing the alarm condition and viewing associated alarm messages.

NOTE: Referred to as "Alarm Button" throughout the manual.

12. Alarm Light; indication of low material supply, bad data, control or motor failure, an open safety switch, or other problem areas.

DIAGNOSTICS MENU AND FUNCTIONS

**Diagnostics Menu Listing
Using Diagnostic Functions
Function Summaries And Uses**

DIAGNOSTICS MENU LISTING

To monitor and change setpoints in diagnostics, you must first enter a correct access code. Listed below are the operator access codes available.

<u>Operator Access Codes</u>	<u>Functions</u>
1	Expected Rate
2	Analog Output Setpoint
3	▶ Print Interval
5	Machine Totalizer
6	Clear Totalizers
7	Alarm Mode
54	★ Screen Intensity
154	✓ SPI Setup (Node and Baud Rate)
254	Mixer Reset Time
454	Load Times
455	Dump Times
456	Loader Type
457	No. of Load Cycles Before Alarm
458	Loader Control (Control Type)
459	Hopper Sensor Type
460	★ 5th Loader for use w/Analog Output
461	★ Hopper Low Level Sensors
554	Auger Shaft Speed
654	Real-Time clock
754	Calibration
755	Calibration Stop Mode
756	Edit Calibration Data
757	Hopper Clean-Out
854	Mixer Level Mode
855	Mixer Sensors
856	Measurement System

- ▶ Indicates functions used only in RS-232 applications
- ★ Indicates functions not used in LCD applications.
- ✓ Indicates functions used only in SPI applications

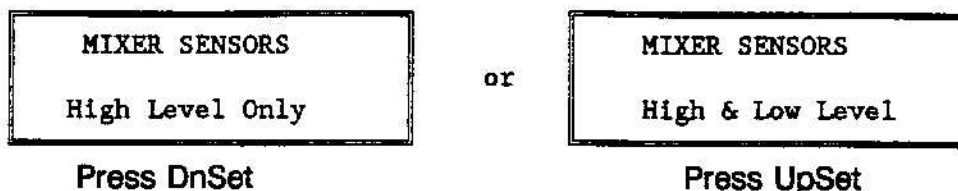

The blender homes in on a process throughput rate through the use of material level sensors in the mixing chamber.

The control operates in one of two ways:

1. High Level Only - One Level Sensor in the mixing chamber tries to maintain the material level at a single level to match the process rate.
2. High & Low Level - Two level sensors in the mixing chamber try to maintain the material level within a specific range to match the process rate.

Check the number of level sensors dedicated to the mixing chamber and choose an operational mode as follows:

One Sensor - Press DnSet

Two Sensors - Press UpSet

Exit Diagnostic Function 855 by pressing the UpSELECT Button(7A).

Access Code 856- Measurement System

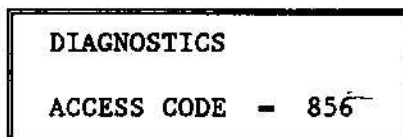

Advance to Access Code 856 using the SET Buttons.
Press the DnSELECT Button (7B) and the display will read:

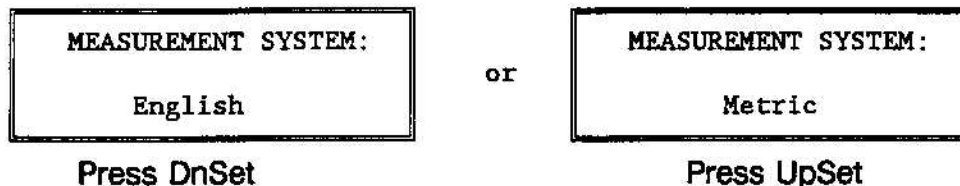

Designate the required unit of measure using the SET Buttons as indicated.

Exit Diagnostic Function 856 by pressing the UpSELECT Button(7A).

Use Set Buttons as indicated to designate mode of operation.

Continuous Mode - Standard blender operation with blender homing in on the process rate.

Cycling Mode - "ON" (100%) or "OFF" (0%) operation only. Blender does not home in on process rate. "ON" throughput determined by next screen.

Press DnSELECT Button (7B) and the display will read:

BLENDER MASTER SPEED	
SP	50%

For Cycling Mode only. SP determines the blenders total throughput when the blender is "ON".

Press DnSELECT Button (7B) and the display will read:

BLENDER RESTART TIME	
SP	30 Sec.

Range - 2 - 60 Sec.

For Cycling Mode only. SP determines length of delay time after mixer full condition and before blender restarts.

Exit the Mixer Level Mode function by pressing the UpSELECT Button until the display returns to the "Diagnostics Access Code" screen.

Access Code 855 - Mixer Sensors

DIAGNOSTICS	
ACCESS CODE	- 855

Advance to Access Code 855 using the SET Buttons.
Press the DnSELECT Button (7B) and the display will read:

To change or set the Real-Time Clock:

Press the Alarm Button (11) to enable the edit mode.

NOTE: The "hours" number pair will begin flashing.

Use the SET BUTTONS (9A and 9B) to increase or decrease the flashing number.

Press the DnSelect Button and the number pair to the right will begin flashing.

Press the UpSelect Button and the number pair to the left will begin flashing.

Press the Alarm Button (11) again when the correct time and date have been entered. This locks the displayed information and restarts the Real-Time Clock.

Exit Diagnostic Function 654 by pressing the UpSELECT Button(7A).

Access Code 754 - Calibration

Access Code 755 - Calibration Stop Mode

Access Code 756 - Edit Calibration Data

Access Code 757 - Hopper Clean-Out

SEE CHAPTER 7 - BLENDER
CALIBRATION

Access Code 854 - Mixer Level Mode

DIAGNOSTICS
ACCESS CODE - 854

Advance to Access Code 854 using the SET Buttons.

Press the DnSELECT Button (7B) and the display will read:

MIXER LEVEL MODE
Continuous Mode

Press DnSet

or

MIXER LEVEL MODE
Cycling Mode

Press UpSet

Access Code 554 - Auger Shaft Speed

```
DIAGNOSTICS
ACCESS CODE - 554
```

Advance to Access Code 554 using the SET Buttons.
Press the DnSELECT Button (7B) and the display will read:

```
AUGER SHAFT SPEED
AUGER #1: STOPPED
```

or

```
AUGER SHAFT SPEED
AUGER #1: CHECKING
```

followed by:

```
AUGER SHAFT SPEED
AUGER #1: xxx RPM
```

Function Summary: Shows instantaneous readout of Auger shaft speed.

Press the DnSELECT Button to advance from Auger #1 through Auger #4.

Exit diagnostic function 554 by pressing the UpSELECT Button (7A) until the display returns to the "Diagnostic Access Code" screen.

Access Code 654 - Real-Time Clock

```
DIAGNOSTICS
ACCESS CODE - 654
```

Advance to Access Code 654 using the SET Buttons.
Press the DnSELECT Button (7B) and the display will read:

```
REAL-TIME CLOCK
T HH:MM:SS D MM/DD/YY
```

Time - Hours: Minutes: Seconds
DATE - Month/Day/Year

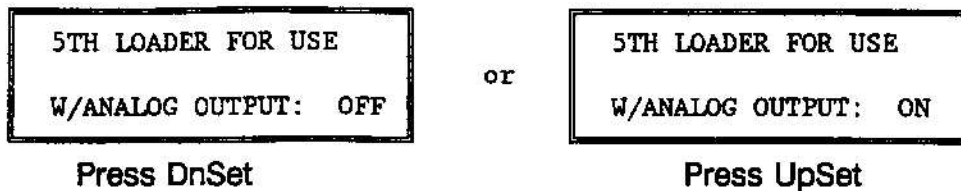

When using the analog output (See Diagnostics Access Code 2) and the use of a loader is required, press the UpSet Button to activate the 5th loader function to ON mode.

Exit diagnostic function 460 by pressing the UpSELECT Button (7A).

This function not available for use. Select "OFF" position to deactivate.

Access Code 461 - Hopper Low Level Sensors (Not available with LCD Display)

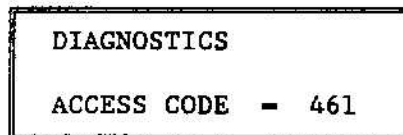

Advance to Access Code 461 using the SET Buttons.
Press the DnSELECT Button (7B) and the display will read:

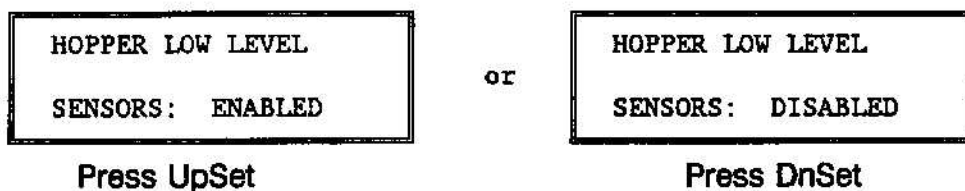

If the blender hoppers are equipped with low level hopper sensors, press the UpSet Button (9A) to enable. NOTE: When in the Enabled Mode, Access Code 457 (No. of Load Cycles before alarm) becomes N/A (not applicable).

When Disabled Mode is chosen, be sure to enter Access Code 457 and set the No. of Load Cycles.

Exit diagnostic function 461 by pressing the UpSELECT Button (7A).

2. Loader Demand Switches (if using the Conomix Plus Internal Loader Control, implemented through Access Code 458).

Use the following chart to determine the proper Sensor Type for the given situations:

ACCESS CODE 459 Hopper Sensor Type	ACCESS CODE 458 Loader Control	ACCESS CODE 461 Low Level Sensor
N.O. *	Conomix Plus	Enabled *
N.O. *	Conomix Plus	Disabled
N.O.	External	Enabled *
N.C.	External	Disabled

- * Using Conair Loaders with demand switches wired in the normally open position - see Blender Terminal Box Wiring diagram in the Appendix for correct loader demand switch wiring.
- * When the low level sensor is enabled, all installed hopper positions should have a level sensor; otherwise, any position(s) missing the level sensor will appear "empty" to the control. **NOTE:** When using the internal Conomix Plus Loader control, the loader demand switch, when full, will override the low level switch.

Choose the desired Hopper Sensor Type using the SET BUTTONS (9A and 9B).

Exit diagnostic function 459 by pressing the UpSELECT Button (7A).

Access Code 460 - 5th Loader for use with Analog Output (Not available with LCD Display)

DIAGNOSTICS
ACCESS CODE - 460

Advance to Access Code 460 using the SET Buttons. Press the DnSELECT Button (7B) and the display will read:

Access Code 458 - Loader Control

DIAGNOSTICS
ACCESS CODE - 458

Advance to Access Code 458 using the SET Buttons.
Press the DnSELECT Button (7B) and the display will read:

LOADER CTRL: INTERNAL
CONOMIX + CONTROL PCB

or

LOADER CTRL: EXTER-
NAL CNTRL ON LOADER

Loader Control is accomplished through 1 of 2 methods:

1. Internal Conomix + Control PCB - Press DnSet
2. External Control on Loader - Press UpSet

Exit diagnostic function 458 by pressing the UpSELECT Button (7A).

Access Code 459 - Hopper Sensor Type

DIAGNOSTICS
ACCESS CODE - 459

Advance to Access Code 459 using the SET Buttons.
Press the DnSELECT Button (7B) and the display will read:

HOPPER SENSOR TYPE
NO: CLOSED WHEN FULL

Press UpSet

or

HOPPER SENSOR TYPE
NC: OPEN WHEN FULL

Press DnSet

This screen is valid for the following:

1. Hopper Low Level Sensors (if installed in the material hoppers and enabled through Access Code 461).

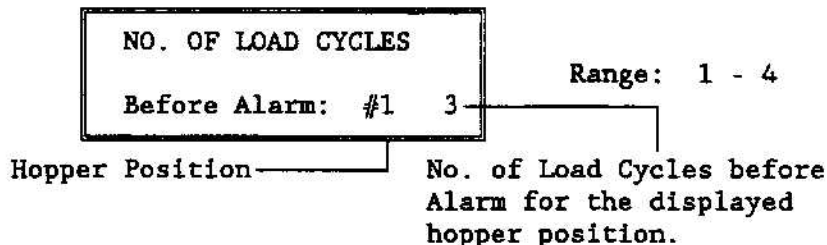

This control function assists in alerting the operator to potential low material levels in material hoppers.

When material in a blender supply hopper drops below the demand sensor, a demand for material is created. The demand for material activates a loader to load and then discharge material into the blender supply hopper. The material demand is canceled when the demand sensor "sees" material again.

The control can monitor the number of loader cycles that take place after the initial demand but before the demand sensor is satisfied. If the number of load cycles reaches the number selected in this diagnostic function, an alarm will sound. The alarm signifies the loading system is not satisfying the throughput requirement.

NOTE: If supply hopper low level sensors are installed and enabled (see Diagnostics Access Code 461), this diagnostic function is NOT APPLICABLE, and the display will read:

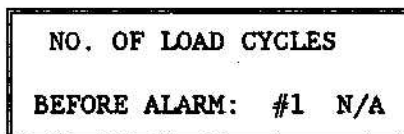

Use the SELECT Buttons (7A and 7B) to advance from hopper #1 through #4.

Use the UpSet and DnSet Buttons to choose the "number of load cycles before alarm" for each hopper position.

Exit Diagnostic Function 457 by pressing the UpSELECT Button (7A) until the display returns to the "Diagnostics Access Code" screen.

Access Code 456 - Loader Type

DIAGNOSTICS
ACCESS CODE - 456

Advance to Access Code 456 using the SET Buttons.
Press the DnSELECT Button (7B) and the display will read:

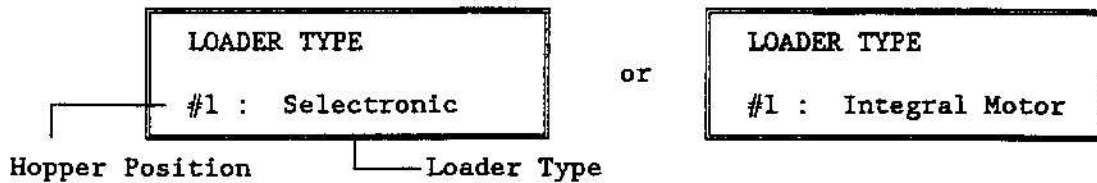

The "Loader Type" screen allows you to designate 1 of 2 possible methods of filling the blender material hoppers. These types include:

SELECTRONIC - The loader functions with a remotely mounted pump and is usually part of a system of loaders, on the blender.

INTEGRAL MOTOR - The loader is self-contained and can load material at any time, based on hopper demand.

Choose a Loader Type using the SET BUTTONS (9A and 9B).

Use the SELECT Buttons (7A and 7B) to advance through the different auger positions.

Exit the Loader Type function by pressing the UpSELECT Button until the display returns to the "Diagnostics Access Code" screen. NOTE: Set the Loader Type for each auger position.

Access Code 457 - No. of Load Cycles Before Alarm

DIAGNOSTICS
ACCESS CODE - 457

Advance to Access Code 457 using the SET Buttons.
Press the DnSELECT Button (7B) and the display will read:

Control Summary:

Use the SET BUTTONS (9A and 9B) to increase or decrease the displayed Dump Time SetPoint from 1 to 99 seconds.

Use the SELECT Buttons (7A and 7B) to advance through the different auger positions.

Exit the DUMP Time function by pressing the UpSELECT Button until the display return to the "Diagnostics Access Code" screen. NOTE: Set the Dump Time for each auger position.

Function Summary:

Dump Time is the time required for the loader to completely empty a full load of material

The Dump Time SetPoint represents the minimum time between load cycles during which a loader can discharge material. (For "Positive Discharge" Loaders, Dump Time represents the length of time the discharge valve remains open.)

Dump Time required is affected by loader size, material flow properties, static, and other conditions. The Dump Time should always be set to allow the loader to empty completely to obtain maximum loader efficiency and, in turn, optimum blender performance.

Setting the Dump Time:

1. Enter a SetPoint greater than the time required to completely empty the loader (typically 10 seconds).
2. After the blender is in operation, measure the actual discharge time.
3. Add two seconds to the measured discharge time and enter value into the Dump Time function.

NOTE: Repeat this process for each loader.

Function Summary:

The Load Time is the maximum length of time the loader is permitted to "pull" material to the displayed position during a single load cycle.

Load Time will vary with material type, conveying distance, filter condition, temperature and other conditions.

Select an appropriate Load Time as follows:

1. Enter a time for each Auger Position that is longer than necessary to fill the loader (typically 40 sec.).
2. After the blender is in operation, measure the actual time required to fill the loader.

The actual load time can be measured in 1 of 2 ways, depending on the type of loader pulling material.

1. Loader w/Full Sensor - Begin timing when the loader begins pulling material and stop timing when the loader stops.
2. Loader without Full Sensor - Begin timing when the loader begins pulling material and stop timing when the material line flow stops. If the material line flow to the loader cannot be observed, stop timing when a change in pitch, similar to blocking the inlet to a vacuum cleaner, is noticed during loader operation. This signifies the loader is full.
3. Increase the measured load time for each auger position by 5% and enter each value into the load time function.

Access Code 455 - Dump Times

DIAGNOSTICS
ACCESS CODE = 455

Advance to Access Code 455 using the SET Buttons.
Press the DnSELECT Button (7B) and the display will read:

DUMP TIME
Auger #1: 10 Sec.

Dump Time range:
1 - 99 Sec.

MIXER RESET TIME	
SP	400 SEC.

The Mixer Reset time SP can be adjusted through a range of 400 - 900 seconds using the SET Buttons (9A and 9B).

The function of this diagnostic position is to adjust the amount of time that is required before the blender algorithm, used to home in on process rate, changes from gross speed adjustment to minimal speed adjustment.

Example: If the material level in the mixing chamber is maintained at the normal operating level longer than the SetPoint of 400 seconds and then requires a rate change to maintain the material level, the rate adjustment in this case will be minor (approx. 1%).

Exit diagnostic function 254 by pressing the UpSELECT Button until the display returns to the Diagnostics Access Code screen.

Access Code 454 - Load Times

DIAGNOSTICS
ACCESS CODE - 454

Advance to Access Code 454 using the SET Buttons.
Press the DnSELECT Button (7B) and the display will read:

LOAD TIME
Auger #1: 10 Sec.

Load Time range:
2 - 99 Sec.

Control Summary:

Use the SET BUTTONS (9A and 9B) to increase or decrease the displayed Load Time SetPoint from 2 to 99 seconds.

Use the SELECT Buttons (7A and 7B) to advance through the different auger positions.

Exit the Load Time function by pressing the UpSELECT Button until the display returns to the Diagnostics Access Code screen. **NOTE:** Set the Load Time for each auger position.

NOTE: We recommend using an intensity setting consistent with operating conditions, using dimmer settings where ambient lighting permits to maximize display screen life.

When the correct screen intensity has been chosen, exit diagnostic function 54 by pressing UpSELECT (7A).

Access Code 154 - SPI Setup

DIAGNOSTICS
ACCESS CODE - 154

Advance to Access Code 154 using the SET Buttons.
Press the DnSELECT Button (7B) and the display will read:

SPI SETUP
NODE ADDRESS - 32

Use the SET Buttons (9A and 9B) to change setpoint if required. Setpoint should be 32. (Setpoints of 33 through 64 are also available)

Next push DnSELECT Button (7B). Display will read:

SPI SETUP
BAUD RATE - 9600

Use the SET Buttons (9A and 9B) to change setpoint if required. Setpoint should be 9600. (Setpoints of 1200, 2400, 4800 & 9600 available)

Exit diagnostic function 154 by pressing the UpSELECT Button until the display returns to the Diagnostics Access Code screen.

Access Code 254 - Mixer Reset Time

DIAGNOSTICS
ACCESS CODE - 254

Advance to Access Code 254 using the SET Buttons.
Press the DnSELECT Button (7B) and the display will read:

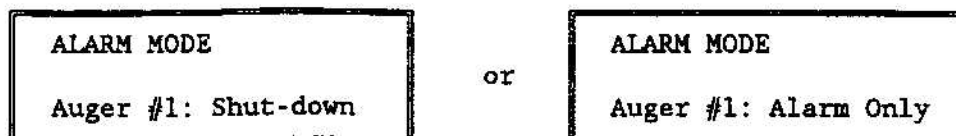

For each hopper position the control gives the user the choice of either shutting down or alarming only if that hopper runs out of material.

If SHUT-DOWN is selected and that hopper runs out of material, the alarm will sound and all four augers will shut down.

If ALARM ONLY is selected and that hopper runs out of material, the alarm will still sound but only the auger that has no material will stop while the other auger(s) will continue to run. The typical use for this feature would be to keep a production line running, even if you run out of regrind, until more can be supplied.

CONTROL SUMMARY

Press the UpSET Button (9A) to activate the ALARM ONLY mode.

Press the DnSET Button (9B) to activate the SHUT-DOWN mode.

Use the SELECT Buttons (7A and 7B) to advance to each of the remaining Auger Positions.

After the ALARM MODE has been set for all of the positions, exit diagnostic Function 7 by pressing the UpSELECT Button until the display returns to the "Diagnostics Access Code" screen.

Access Code 54 - Screen Intensity (Vacuum Fluorescent Display ONLY)

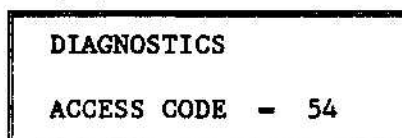

Advance to Access Code 54 using the SET Buttons.
Press the DnSELECT Button (7B) and the display will read:

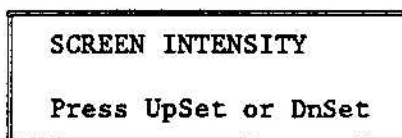

Use the SET BUTTONS (9A and 9B) to adjust the brightness of the display characters to 1 of 4 possible intensity levels to suit your specific requirements.

Press UpSET (9A) to BRIGHTEN character intensity.

Press DnSET (9B) to DIM character intensity.

Access Code 6 - Clear Totalizers

DIAGNOSTICS
ACCESS CODE - 6

Advance to Access Code 6 using the SET Buttons.
Press the DnSELECT Button (7B) and the display will read:

CLEAR TOTALIZER
Press UpSet to clear

This function will return the machine totalizers (See Totalizer, Chapter 5) to zero to begin accumulating a new set of metered material weights through each auger position. The total material metered through the blender (See Diagnostics Access Code 5) is also reset to zero.

Press the UpSET Button (9A) to clear Totalizers if desired.

The display will then read:

CLEAR TOTALIZER
TOTALIZER CLEARED

Exit diagnostic function 6 by pressing the UpSELECT Button (7A).

Access Code 7 - Auger Alarm Mode

DIAGNOSTICS
ACCESS CODE - 7

Advance to Access Code 7 using the SET Buttons.
Press the DnSELECT Button (7B) and the display will read:

Access Code 3 - Print Interval

DIAGNOSTICS
ACCESS CODE - 3

Advance to Access Code 3 using the SET Buttons (7A and 7B).
Press the DnSELECT Button (7B) and the display will read:

PRINT INTERVAL
NOT IMPLEMENTED

or

PRINT INTERVAL
0 Min.

SPI Application

RS232 Application

NOTE: For SPI Applications, this screen is de-activated

For RS232 Applications, use this screen to choose the time interval at which information will be sent to the printer port.

Use the SET BUTTONS (9A, 9B) to change the setpoint. [Print Interval = 0 - 60 Min.]

Exit diagnostic function 3 by pressing the UpSELECT Button (7A).

Access Code 5 - Machine Totalizer

DIAGNOSTICS
ACCESS CODE - 5

Advance to Access Code 5 using the SET Buttons.
Press the DnSELECT Button (7B) and the display will read:

MACHINE TOTALIZER
7777 lb

This diagnostics position displays the total material metered for this recipe since the last Totalizer reset. (Totalizer range is 0 - 9,999,999 Lbs.)

Exit diagnostic function 5 by pressing the UpSELECT Button (7A).

information, the control can alert you if the blender will not be able to achieve this rate even before any material is metered. This can save shutdowns, material loss, and many other problems caused by a lack of material supplied to the process equipment.

NOTE: If nuisance alarms occur during setup, leave setpoint at 0.0 Lb/Hr until setup is complete and the blender is ready to run.

Press the UpSELECT Button (7A) to exit this function.

Access Code 2 - Analog Output

DIAGNOSTICS
ACCESS CODE - 2

Advance to Access Code 2 using the SET Buttons.
Press the DnSELECT Button (7B) and the display will read:

ANALOG OUTPUT
SP 0%

Use the SET BUTTONS (9A, 9B) to change the setpoint.

Exit diagnostics position 2 by pressing the UpSELECT Button (7A).

The analog output function provides a signal from the blender control that can be used to drive other equipment that must maintain a relationship to the blend. The provided output signal is 0 - 10VDC and is dependent on both the displayed SP and the total blender throughput percentage (i.e. 10VDC is provided when SP = 100% and the blender is running at 100% total throughput capacity).

The analog output source is provided from pins 1(-) and 2(+) of block J2 on the I/O PC Board (see blender control box schematic, sheet 2, in the Appendix).

USING DIAGNOSTIC FUNCTIONS

Proceed to Diagnostics using the DnSELECT Button (7B).
The display will read:

DIAGNOSTICS
Access Code - 0

Use the SET Buttons (9A and 9B) to change the ACCESS CODE.
Press the UpSET Button to increase the access code.
Press the DnSET Button to decrease the access code.

Use the SELECT Buttons (7A and 7B) to ENTER and EXIT a Diagnostic Function.
Press DnSELECT to enter a diagnostic function.
Press UpSELECT to exit a diagnostic function.
Press UpSELECT to exit the Diagnostic Menu when viewing
the "Diagnostic Access Code" screen.

FUNCTION SUMMARIES AND USES**Access Code 1 - Expected Rate**

DIAGNOSTICS
ACCESS CODE - 1

Advance to Access Code 1 using the SET Buttons.
Press the DnSELECT Button (7B) and the display will read:

EXPECTED RATE
0.0 lb/hr

The expected rate setpoint can now be changed using the SET BUTTONS (9A, 9B).

This setpoint does not have to be entered (it may be left at 0.0), but can be helpful if entered as slightly more than (approx. 2%) your expected process rate. With this

BLENDER CALIBRATION

**Volumetric Calibration
Calibration Stop Mode
Edit Calibration Data
Hopper Clean-Out
Calibration Data Log**

VOLUMETRIC CALIBRATION - ACCESS CODE 754

During this diagnostic function, material will be metered through auger positions you select at factory pre-set motor speeds.

During the metering portion of the calibration cycle, the control will monitor the metering time for each position, then afterward compare that time with the calibration weights of the material samples you collect and weigh. The Conomix control uses this information to calculate throughput rates for each position.

Once the control records these individual throughput rates, the blender can calculate rates for different recipes as well as alarm against rates or recipes that are not attainable with the existing setup.

Step 1 : Advance to the Diagnostics screen of the Select Menu using the Select Buttons (7A & 7B). The display will read:

DIAGNOSTICS
Access Code - 0

Step 2 : Use the SET Buttons (9A and 9B) to advance to Access Code 754. The display will read:

DIAGNOSTICS
ACCESS CODE - 754

Step 3 : Press the DnSELECT Button and the display will read:

CALIBRATE *
Auger No(s) 1 2 3 4

This display gives you the choice of calibrating any auger independently and up to 4 augers simultaneously.

Use the SET Buttons (9A & 9B) to move the indicator asterisk above the Auger Number you would like to calibrate.

Press the ALARM Button (11) to select the Auger Number directly below the indicator asterisk. The selected auger number will begin flashing. You may select any or all of the hopper positions shown for a calibration run.

To CANCEL a selected Auger Number, move the indicator asterisk above the Auger Number to be canceled and press the ALARM Button. The Auger Number will stop flashing.

HOPPER CLEAN-OUT - ACCESS CODE 757

DIAGNOSTICS
ACCESS CODE - 757

Advance to Access Code 757 using the SET Buttons.
Press the DnSELECT Button (7B) and the display will read:

HOPPER CLEAN-OUT
Loader #1: Enabled

or

HOPPER CLEAN-OUT
Loader #1: Disabled

Press UpSet

Press DnSet

The hopper Clean-Out function controls the status of the loader for each position.

Enabled Mode allows the loader to operate normally, based on supply hopper demand.

Disabled Mode prevents the loader from loading by interrupting the demand signal to the loader, allowing for emptying and cleaning of a supply hopper.

CONTROL SUMMARY

Use the SET BUTTONS to change the status of a hopper position

Use the Select Buttons to select different hopper positions.

[DnSelect to move from position 1 through 4.]

[UpSelect to move from position 4 through 1.]

Exit Hopper Clean-Out Function by pressing the UpSELECT Button (7A).

HINT: To simplify the editing process, use the same time interval for a given blender position each time it is calibrated. Since the time interval is constant, a new calibration weight doesn't need to be scaled - just enter the value from the Calibration Data Log and your recipe is updated and valid.

The following example illustrates the Edit Function:

	<u>Auger Size</u>	<u>Calibration Time</u>	<u>Calibration Weight</u>
Current Ingredient	3/4"	15 Min 0 Sec	18.0 Lbs.
New Ingredient	3/4"	7 Min 30 Sec	15.0 Lbs.

Display now reads:

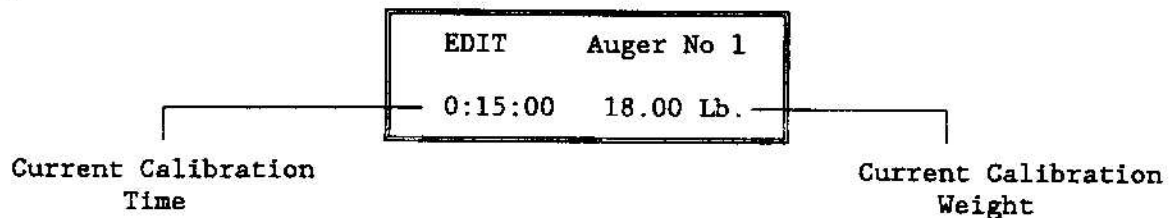

If switching from the current ingredient to the new ingredient, the calibration data must be changed to represent the new ingredient. Since the Calibration Time cannot be changed without re-calibrating, the Calibration Weight for the new ingredient should be scaled to the current Calibration time and entered as follows:

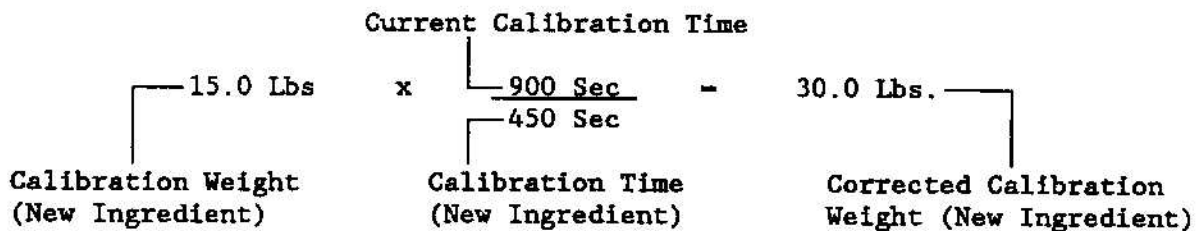

Use the SET Buttons to enter the corrected calibration weight for the new ingredient.

CONTROL SUMMARY

Use the SET Buttons (9A and 9B) to increase or decrease the displayed calibration weight.

Press the DnSelect Buttons to advance to the next auger position.

Press the UpSelect Button to return to the previous auger position.

Exit the Edit function by pressing the UpSelect Button until the display returns to the "Diagnostic Access Code" screen.

EDIT CALIBRATION DATA - ACCESS CODE 756

DIAGNOSTICS ACCESS CODE - 756

Advance to Access Code 756 using the SET Buttons.
 Press the DnSELECT Button (7B) and the display will read:

Auger Position - Press DnSelect to advance from 1 through 4; Press UpSelect to advance from 4 through 1.

EDIT	Auger No. 1
H:MM:SS	0.10 Lb.

Calibration time for current calibration data in Hours:Minutes:Seconds
 This is a READ ONLY value and cannot be edited.

Current Data - Calibration sample weight - Range - 0.10 to 15000.00
 Press UpSet to increase weight
 Press DnSet to decrease weight.

The information shown represents the current calibration data for the displayed auger position. The calibration sample weight represents the total amount of material metered during the last calibration run, while the calibration time represents the time the auger needed to meter that material.

The Edit function allows the user to change or re-enter the calibration sample weight entered during the last calibration run (see Access Code 754 for details).

The Calibration Data for a newly selected recipe should be changed when one or more ingredients undergo a change in bulk density or flow characteristics from the previous recipe, or the auger size is changed. This change is accomplished in one of two ways:

1. Re-Calibrate the auger position containing the new ingredient (See Access Code 754).
2. Edit the calibration sample weight for that auger position - if the new ingredient has been previously calibrated and it's data recorded in the log provided later in Chapter 7, the calibration data is valid and can be scaled to the displayed calibration time, eliminating the need to re-calibrate the position.

NOTE: Please enter your recipe calibration data in the Calibration Data Log at the end of this chapter.

Press the Alarm Button to advance to the next auger position selected for calibration. If no other augers were selected for calibration, pressing the Alarm Button will return to the original calibration screen:

CALIBRATION	*
Auger No(s)	1 2 3 4

Press RUN to begin a new calibration sequence, selecting auger positions as before in Step 3 of this section.

CALIBRATION STOP MODE - ACCESS CODE 755

DIAGNOSTICS
ACCESS CODE - 755

Advance to Access Code 755 using the SET Buttons.
Press the DnSELECT Button (7B) and the display will read:

CALIBRATION STOP
MODE: Automatic

or

CALIBRATION STOP
MODE: Manual

Press UpSet

Press DnSet

Use the SET Buttons as indicated to choose the desired mode.

AUTOMATIC - The user chooses a time interval for the sample, then once the calibration run has reached its metering cycle, the auger will run until their calibration times have expired. **NOTE:** Press the STOP Button to override the remaining time and stop the auger(s) immediately.

MANUAL - When the metering cycle begins, the Elapsed Time for the metering augers is displayed and continues to go forward until the STOP Button is pressed. All augers meter for the same length of time.

Exit Diagnostic Function 755 by pressing the UpSELECT Button (7A).

When all of the augers have completed the Calibration Cycle, the display will advance to:

Enter Weight for
Auger #3 0.10 Lb.

(See Below)

Enter Weight or
Auger #3 0.10 Lb.

Weight of sample collected
during calibration
Range - 0.10 through 15000.00

Step 6: Take sample collected during the timed calibration and weigh it on an accurately calibrated scale.

Enter the measured sample weight using the SET Buttons. The UpSet Button increases the displayed weight and the DnSet Button decreases the displayed weight.

After the correct weight has been entered, press RUN.

Screen will advance to the next auger position that was selected for calibration. Enter the appropriate weight as described above and press RUN.

If no other augers were selected, the display will read:

CALIBRATION STATUS
Press Alarm Silence

If the calibration was successful, pressing the Alarm button results in the following:

#3 CALIBRATED
All Cal. Data O.K.

or

2. The auger(s) should run at least 15 minutes.

When a sufficient length of time has elapsed, press the STOP button to stop the auger(s) from turning.

The display will read:

Enter Weight for
Auger #3 0.10 Lb.

(See Below)

Press RUN after the correct calibration time is entered. The screen will advance to the next auger position selected for calibration.

If no other augers were selected, the calibration will begin and the selected augers will rotate at a constant, pre-set speed (approximately 120 RPM). The display will change momentarily to:

Calibration Started
PLEASE WAIT

followed by:

1 OFF	2 OFF
3 H:MM:SS	4 OFF

Time remaining for calibration sample.

This display shows the calibration status of each auger position. Each position will display 1 of the following 3 messages:

OFF - Position not selected for calibration.

DONE - Sample time expired, calibration complete.

H:MM:SS - Time remaining

Seconds
Minutes
Hours

NOTE: Press the STOP Button to stop the augers before their time remaining has expired.

NOTE: At this point in the calibration, the operating sequence will follow one of two paths - "Automatic" or "Manual" calibration stop. (See Access Code 755 for details on selecting a calibration stop mode.)

For "Automatic" Cal Stop Mode, continue with Section B.

For "Manual" Cal. Stop Mode, continue with Section A.

Section A
"Manual" Calibration Stop Mode

Press RUN to Start
Calibration

Press the RUN button and the display will read:

Calibration Started
PLEASE WAIT

followed by:

Push STOP to end Cal.
Elapsed Time H:MM SS
Hours
Minutes
Seconds

The augers will begin turning as the timer begins counting.

NOTE: The metering portion of the Conomix calibration should last long enough to satisfy one of the following two conditions:

1. The selected auger(s) should empty approx. 70% of its total supply hopper(s) capacity.

Section B
"Automatic" Calibration Stop Mode

Enter Cal. Time for
Auger #3 H:MM:SS
Hours
Minutes
Seconds

Use the SET BUTTONS (9A and 9B) to increase or decrease the calibration time SetPoint.

Choose a calibration time to satisfy 1 of the following 2 requirements:

1. The auger should meter at least 70% of the supply hopper capacity

or

2. The auger should run at least 15 minutes.

NOTE: DO NOT ALLOW THE SUPPLY HOPPER TO BE COMPLETELY EMPTIED DURING A CALIBRATION RUN. If this happens, the calibration is invalid and must be repeated with a shorter calibration time.

We will choose Auger #3 as the auger we want to calibrate first in this example. To select 3, use the DnSET Button to move the indicator asterisk until it is located above Auger Number "3". The display will read:

CALIBRATE	*
Auger No(s) 1 2 3 4	

Push the Alarm Button to select Auger No. 3 for calibration and the number "3" will begin flashing.

Step 4 : Press the Run Button (10A) and the display will read:

Place buckets under augers & press RUN

The "buckets" should be large enough to run almost a full weighed hopper of material (up to 120# on largest bin). Also, the Calibration Diverter Chutes should be diverted to the Calibration position.

Step 5 : Press the Run Button. If the hoppers need material the display will read:

Filling Hoppers PLEASE WAIT

The loaders will now load material into the supply hopper(s) of the blender. When the hopper(s) is full, the display will read:

Hoppers full. Press RUN to flood augers
--

Press the Run Button and wait for material to flood the auger(s) (until material flows from the auger housing calibration chutes). The amount of time required for this is dependent upon the auger size and material and will range from approximately 2 to 10 seconds. The display now reads:

Press STOP when all augers are flooded

Push the STOP Button. The auger motors will stop and the display will read:

BLENDER OPERATION

**Review Of Start-Up Procedures
Accuracy And Taking Material Samples**

REVIEW OF START-UP PROCEDURES

After having completed the blender setup and calibration sequences described earlier in this manual, you should review the following information as a "check list" when operating the blender.

1. Choose a recipe number (Chapter 5 - Selecting a Recipe).
2. Enter a recipe (Chapter 5 - Creating/Editing a Recipe).
3. Reset the totalizer (Chapter 6 - Function Summaries and Uses, Access Code 6).
4. Check that the material supply is sufficient.
5. Set the Calibration/Sample chutes to the Run position (Chapter 1 - Calibration Sample Chute).
6. Check that the rate auger (if used) is on and functioning properly at the correct speed.
7. Check that the mixing chamber agitator is on.

You are now ready to start the blender.

Push the Run/Setup toggle switch to "RUN". The blender augers will rotate at the highest speed possible while maintaining the proportions of the recipe (100% maximum throughput).

Because the initial input to the mixing chamber will be higher than the process take away rate, the mixing chamber will go from empty to full. This will signal the control that the metering augers can run at slower speeds while still maintaining the correct proportions. The control will correct the total rates of the metering augers to match the throughput of the rate auger or process rate. This is the ideal "RUN" condition, because the augers will run continuously and the residence time of the material in the mixing chamber will be constant.

Once the blender has been running and has "homed in" on the process rate, you can check its operation quickly and easily by doing the following:

Check the "totalizer" for confirmation of the mix.

Monitor the material level of each position by viewing the "Hopper Level" screen (Chapter 5 - Select Menu) to confirm proper blender operation.

In these setups, the mixing chamber will not fill up, so the blender will run at the rate it has previously homed in on and the only changes in motor speed will be those dictated by the control while monitoring the recipe throughput.

After an appropriate amount of material (drum full) has been metered, press the STOP Button (10B). The material samples can now be weighed and compared.

In our example, assume the total material collected to be 217.4 pounds of virgin, 27.3 pounds of additive "A", 21.8 pounds of additive "B", and 5.4 pounds of color.

First, total these actual weights.

217.4
27.3
21.8
<u>5.4</u>
272.0 Pounds

Next, multiply the total weight by the setpoints in the recipe. This is the target weight.

272.0 x .80 = 217.60
272.0 x .10 = 27.20
272.0 x .08 = 21.76
272.0 x .02 = 5.44

Compare target weights to actual weights to find the deviation from the target weights.

217.4 actual - 217.60 target = -.2 pounds difference
27.3 actual - 27.20 target = +.1 pounds difference
21.9 actual - 21.76 target = +.14 pounds difference
5.4 actual - 5.45 target = -.04 pounds difference

Finally, use the deviation from the target weight to show variation from setpoint.

<u>-.2 pounds difference</u>	
217.60 target	= 0.092% of virgin (light)
<u>+.1 pound difference</u>	
27.20 target	= 0.368% of additive "A" (heavy)
<u>+.14 pounds difference</u>	
21.76 target	= 0.643% of additive "B" (heavy)
<u>-.04 pounds difference</u>	
5.44 target	= 0.735% of color (light)

ACCURACY AND TAKING MATERIAL SAMPLES

To confirm that the blend is consistent with the proportions of the recipe, you can collect material samples, weigh them and analyze the results. This section describes both how to properly collect material samples and how to interpret them to determine accuracy.

Example: Recipe #1 is

Auger 1 SP	=	80% Virgin
Auger 2 SP	=	10% Additive "A"
Auger 3 SP	=	8% Additive "B"
Auger 4 SP	=	2% Color

If the samples are taken before the blender has been run, the rate of the four metering augers will be the maximum that the blender can achieve while maintaining the proportions, which will be above the process rate. While these samples will show the accuracy of the blender, they are not as relevant a test as samples collected while the metering augers were running at your actual process rate.

FOR SURGE BIN/GAYLORD FILL APPLICATIONS: To take samples at the process rate, the calibration diverter chute for position #1 (virgin) should be left in the run position so that the material will fill the mixing chamber and "Home In" on the rate of the rate auger. **NOTE:** Only virgin material will run into the surge bin below the blender, so the bin must be clean and empty for this test procedure. Also note the rate of the rate auger should be set at 80% of the expected rate for this recipe.

The diverter valves for positions 2, 3 and 4 should be in the calibrate position and the material diverter into "Buckets" (drums).

Now the blender should be run by turning the Run/Setup toggle switch to the RUN position. This will start all augers turning and let the blender "Home In" on the rate auger. The "Home In" time or time required for the blender to match the process rate will depend on the difference in rate between auger #1 and the rate auger, as well as the volume of the mixing chamber. To check that the blender has homed in, monitor the motor speeds of the augers until they change by less than 3%. Now that the blender is running at the process rate, move the Run/Setup toggle switch to SETUP. At this time, turn the rate auger up about 5%. Also at this time, empty the gaylords and make sure that the bin is empty. Samples can now be collected at the process rate by restarting the blender using the RUN Button (10A).

FOR AT-THE-THROAT APPLICATIONS: Stop the blender by moving the Run/Setup toggle switch to the SETUP position while the blender is still "Homed In" on your process rate (when auger motor speed changes are less than 3%). The calibration diverter chutes should be changed to the calibrate position and containers positioned to catch material. You can now catch the samples at the process rate by pressing the RUN Button (10A).

As this example shows, an accurate scale is needed since only 0.04 pounds deviation was 0.7% of the color, while .20 pounds was only 0.1% of the virgin. If we want to measure the accuracy to the tenth of a percent, we will need a scale with a resolution equal to 0.1% (.001) multiplied by sample weight (1000 pounds and above $\times .001 = 1$ pound resolution). If the sample weight is less than 1000 pounds, the scale will have to have the capability to read to the nearest tenth ($1/10$) of a pound ($100 \times .001 = 0.1$). For sample weights less than 100 pounds, the scale should be able to read to the nearest hundredth ($1/100$) of a pound ($10 \times .001 = 0.01$).

This example illustrates that longer sample times will be more accurate.

The material used in this sample test will not be mixed and can be returned to the supply tanks.

TROUBLESHOOTING**<SETUP> Mode****<SETUP> Diagnostics Menu Listing****Using <SETUP> Diagnostic Functions****<SETUP> Diagnostic Function Summaries****Alarms And Possible Causes****Circuit Board LED Identification**

<SETUP> MODE

The blender <SETUP> Mode is identical to the standard operating mode with the exception of Diagnostics Functions.

The <SETUP> Access Codes are available only when the blender is in its <SETUP> mode, which is noted on the display window when viewing the "Recipe No." screen (Select Menu - Pos. 0).

The <SETUP> Access Codes are useful for initial blender setup and troubleshooting during installation, as well as any future troubleshooting that becomes necessary.

Enter the blender <SETUP> Mode as follows:

Push the Power Switch to the ON position. The display will execute the following routine:

```
CONOMIX PLUS  V1.30  
Standard Application
```

```
STORING CALIBRATION  
DATA .... Please Wait
```

```
0 RECIPE  
SP xx INITIALIZING
```

This is the control "loading itself from memory" which lasts approximately ten seconds.

Press UpSELECT while the control is initializing (loading its data into memory). The word initializing will remain on the display for approx. 5 - 10-seconds. (You must press UpSELECT while "Initializing" is still displayed on the screen.)

The display will then read:

```
0 RECIPE <SETUP>  
SP xx
```

The word <SETUP> signifies the control will operate using the <SETUP> Access Codes outlined in this chapter. (As with the standard Diagnostics Menu, the functions accessed through the <SETUP> Diagnostics Menu are operational only when the Run/Setup Switch is in the SETUP position.)

PROCESSOR PC BOARD

<u>LED #</u>	<u>Description</u>
LD1	Receive Data
LD2	Transmit Data
LD3	Direction Pin
LD4	Auger motor #1 metering when lit
LD5	Auger motor #2 metering when lit
LD6	Auger motor #3 metering when lit
LD7	Auger motor #4 metering when lit
LD8	Power (yellow)
LD9	Power (red)
LD10	1 Second Timer

CIRCUIT BOARD LED IDENTIFICATION

I/O PC Board

<u>LOCATION #</u>	<u>LED #</u>	<u>Description</u>	
J3	LD1	Spare Sensor, Auger#1	
J3	LD2	Spare Sensor, Auger#2	
J3	LD3	Spare Sensor, Auger#3	
J3	LD4	Spare Sensor, Auger#4	
J6	LD5	Loader #1 Full (material in loader)	
J6	LD6	Loader #2 Full (material in loader)	
J6	LD7	Loader #3 Full (material in loader)	
J6	LD8	Loader #4 Full (material in loader)	
J5	LD9	Demand Out (to pump)	
J5	LD10	Demand In (a loader needs material)	
J5	LD11	Last Loader	
J5	LD12	Next Loader	
J4	LD15	Load #1 (loader popper valve)	
J4	LD16	Load #2 (loader popper valve)	
J4	LD17	Load #3 (loader popper valve)	
J4	LD18	Load #4 (loader popper valve)	
J4	LD13	Dump #1 (loader discharge valve)	
J4	LD14	Dump #2 (loader discharge valve)	
J4	LD19	Dump #3 (loader discharge valve)	
J4	LD20	Dump #4 (loader discharge valve)	
J4	LD22	Metering Light	
J4	LD23	Alarm Horn	
J11	LD43	Mixer Spare Input	
J11	LD44	Mixer Empty Sensor	
J11	LD45	Mixer Interlock Switch	
J11	LD46	Mixer Full Sensor	
J8	LD31	Hopper #1 Level Sensor	Spare when disabled.
J8	LD32	Hopper #2 Level Sensor	
J8	LD33	Hopper #3 Level Sensor	
J8	LD34	Hopper #4 Level Sensor	

Alarm #6 Bad Data - If a severe power surge or spike occurs and data is lost, this alarm will occur. To solve this problem, the system must be setup again (see Setup and Diagnostics section).

Alarm #7 Motor Overload Auger No. (1-4) - This alarm occurs when an auger motor overloads. The motor will overload if the auger jams with material. Check to see that material is not backed up into auger discharge chute. To solve this problem, remove the auger and sleeve and check for obstructions. Re-install the auger and sleeve or replace the auger if it is bent or damaged.

Turn the power off and back on to reset the motor overload.

Alarm #8 Mixer Interlock Open Check Mixer Cover - As a safety feature, the mixing chamber and metering hoppers have interlocks so that the blender cannot be run without the access doors being secured.

Alarm #9 Memory Failure Check Recipe Data or Check Setup Data or Recalibrate Machine - Data failed to pass integrity tests on power-up, indicating that data may have been corrupted or memory has failed. Cycle the power, then check setup parameters and calibration data. Recalibrate if necessary. If problem persists, consult Conair.

Alarm #10 Check Volume Calibration Auger No. x - Blender tried to adjust an auger's speed to greater than 100% while trying to obtain a throughput rate that should have been attainable based on its Volumetric Calibration Data. Could be caused by the following:

1. Changing an auger/sleeve combination without recalibrating (must recalibrate or edit the volume calibrated data).
2. Switching to a material with a change in bulk density without recalibrating volumetrically.
3. Poor material flow in the material supply hopper.

ALARMS AND POSSIBLE CAUSES

The blender is programmed to give an alarm if any part of its system is not operating properly. The following is a list of possible alarms, their causes and solutions. When alarms occur, the Alarm Light and Horn will sound. Push the ALARM Button and the Horn will be silenced, then press the ALARM Button again and the alarm message(s) will be displayed.

- Alarm #1 Mixing chamber empty - This alarm occurs when the blender is not able to supply enough material to maintain the mixing chamber at its normal operating level (when the material level in mixing chamber fails to reach the mixer full sensor after blender has run at 100% for 10 minutes). This alarm will occur if the augers are too small. Check the auger speeds for optimum metering. The augers should be sized so that they are all turning at 20% to 100%. Refer to the Installation section for changing augers and sleeves. After an auger has been changed, the hopper must be recalibrated.
- Alarm #2 No Material Hopper No. (1-4) - The No Material alarm occurs when the amount of material in a hopper drops to below the hopper low level indicator (if installed, See Access Code 461, Chapter 6) or when the loader demand switch is not satisfied in the specified number of load cycles (see Access Code 457, Chapter 6).
- Alarm #3 Auger No. (1-4) No Throughput - This alarm occurs when a metering auger tries to meter material at less than 2% motor speed. When this occurs, decrease your auger size for that position and recalibrate.
- Alarm #4 Ratio Error Auger No. (1-4) - A Ratio Error can result from a poor auger selection. Check the auger speeds. For optimum recipe accuracy, all auger speeds should be about equal. Increase or decrease auger sizes to improve auger speeds. (See Auger/Sleeve installation section). After changing an auger and sleeve, you must recalibrate that hopper position or edit it's calibration data.
- Alarm #5 Cannot Meet Expected Rate With This Setup - This alarm occurs immediately upon entering the RUN mode when the programmed recipe and setup parameters cannot keep up with the programmed expected rate setpoint. Increase the augers sizes and re-calibrate to increase the throughput rate or check setpoint of expected rate.

```
Motor Output Test
Motor No. - 1
```

Use Set Buttons to change the designated auger motor.

Press DnSelect to view Motor Speed.

```
Motor Output Test
Speed - 100.0%
```

Use SET Buttons to change the displayed % motor speed.

Press the RUN Button to start the designated motor at the displayed speed.

Press the STOP Button to de-energize the motor.

Exit this function by pressing the UpSELECT Button (7A).

Access Code 35 - Watchdog Timer Test

```
DIAGNOSTICS
ACCESS CODE - 15
```

Advance to Access Code 35 using the SET Buttons.
Press the DnSELECT Button (7B) and the display will read:

```
Watchdog Timer Test
Will RESET in 3 Sec.
```

Press the UpSELECT Button (7A) in less than 3 seconds to prevent the control from resetting itself (The control resetting has the same effect as cycling the blender power switch "OFF" and back "ON"). This function is for Conair Troubleshooting purposes only.

<SETUP> Access Code 31 - 36:

Note that these diagnostic screens are for Conair Testing/Troubleshooting purposes only.

Spare Input 9
J11, Pin 5, LED43 OFF

- Spare Input not used.
The following summarizes the Spare Inputs:

<u>Spare Input</u>	<u>Address</u>	<u>Pin</u>	<u>LED</u>
9	J9	5	35
10	J9	4	36
11	J9	3	37
12	J9	2	38

Press UpSet 3 times to advance through the "Spare Input" screens to Spare Input #12.

Counter Sensor #1
J10, Pin 5, LED39 OFF

- OFF - Counter not energized.
ON - Counter energized.

There are 4 "Counter Sensor" screens.
The following summarizes these inputs:

<u>Counter Sensor #</u>	<u>Address</u>	<u>Pin</u>	<u>LED</u>
1	J10	5	39
2	J10	4	40
3	J10	3	41
4	J10	2	42

Press UpSet 3 times to advance through and view the "Counter Sensor" screens, finishing with counter sensor #4.

END OF INPUT TEST

<SETUP> Access Code 30 - Motor Output Test

DIAGNOSTICS
30 Motor Out Test

Advance to <SETUP> Access Code 10 using the SET Buttons.
Press the DnSELECT Button (7B) and the display will read:

<u>Loader Full Sens.</u>	<u>Address</u>	<u>Pin</u>	<u>LED</u>
1	J6	5	5
2	J6	4	6
3	J6	3	7
4	J6	2	8

Press UpSet 3 times to advance through and view the "Loader Full Sens." screens, finishing with Loader Full Sensor #4.

Demand Sensor #1
J7, Pin 5, LED 27 OFF

- ON - Hopper High Level Sensor de-energized (sensor not in contact with material)
- OFF - Hopper High Level Sensor energized (sensor contacting material).

There are 4 "Demand Sensor" screens. The following summarizes these inputs:

<u>Demand Sensor #</u>	<u>Address</u>	<u>Pin</u>	<u>LED</u>
1	J7	5	27
2	J7	4	28
3	J7	3	29
4	J7	2	30

Press UpSet 3 times to advance through and view the "Demand Sensor" screens, finishing with Demand Sensor #4.

Hopper Low Level #1
J8, Pin 5, LED 31 ON

*Spare Input when low level sensor is disabled.

- ON - Hopper Low Level Sensor energized (sensor contacting material).
- OFF - Hopper Low Level Sensor de-energized (sensor not in contact with material).

There are 4 "Hopper Low Level" screens. The following summarizes these inputs:

<u>Low Level Sensor #</u>	<u>Address</u>	<u>Pin</u>	<u>LED</u>
1	J8	5	31
2	J8	4	32
3	J8	3	33
4	J8	2	34

Press UpSet 3 times to advance through and view the "Hopper Low Level" screens, finishing with Hopper Low Level Sensor #4.

Run Switch Input
On Front Panel OFF

- Run/Setup Switch in SETUP position - OFF.
- Run/Setup Switch in RUN position - ON.

Mixer Full Sensor
J11, Pin 3, LED45 OFF

- OFF - Sensor(s) in mixing chamber not in contact with material.
- ON - Sensor(s) in mixing chamber directly contacting material.

Mixer Interlock Sw.
J11, Pin 3, LED45 ON

- ON - All safety switches (mixing chamber door, hopper doors) closed.
- OFF - 1 or more safety switches open.

Mixer Empty Sensor
J11, Pin 4, LED44 OFF

- OFF - Mixer Sensor "High Level Only" Mode.
- OFF - Mixer Sensor "High & Low Level" Mode, Low Level Sensor not in contact with material.
- ON - Mixer Sensor "High & Low Level" Mode, Low Level Sensor directly contacting material.

Spare Input 0
J11, Pin 5, LED43 OFF

- Spare Input not used.
- The following summarizes the Spare Inputs:

<u>Spare Input</u>	<u>Address</u>	<u>Pin</u>	<u>LED</u>
0	J11	5	43
1	J3	5	1
2	J3	4	2
3	J3	3	3
4	J3	2	4

Press UpSet 4 times to advance through the "Spare Input" screens to Spare Input 4.

Loader Full Sens. #1
J6, Pin 5, LED 5 OFF

- OFF - Loader Full Sensor not in contact with material.
- ON - Loader Full Sensor contacting material. Interrupts demand signal at control if energized before load time completed.

There are 4 "Loader Full Sens." screens. The following summarizes these inputs:

<SETUP> Access Code 29 - Input Test

```

*** DIAGNOSTICS****
29 Input Test
    
```

Advance to <SETUP> Access Code 29 using the SET Buttons. Press the DnSelect Button (3B) and the display will read:

```

INPUT TEST
Press UpSet to Start
    
```

The Input Test allows the operator to view the current status of an input.

Press the UpSET Button to advance through the inputs listed on the following pages.

Press the DnSet Button to return to previous inputs and scroll backwards through the inputs listed on the following pages.

INPUT TEST

NOTE: See Appendix for the location of the I/O PC Board referenced below.

```

INPUT TEST
Press UpSET to Start
    
```

- NOTE: The Input Test will advance through each of the inputs transmitting information to the blender control displaying a continually updated status for each.

```

Last Loader
J5, Pin 3, LED11  OFF
    
```

- Last Loader is part of the Conair Selectronic Loading control System and will always be off when the Blender has a pump dedicated exclusively to its loaders, or when Integral Motor Loaders are used.

```

Demand In
J5, Pin 1, LED10  OFF
    
```

- When the Blender is part of a Selectronic Loading Systems, Demand In is tied to the Demand Out signal from other loading stations in the system. When any other station has a Demand Out signal, the Demand In for the blender will be ON. When the Blender has a dedicated pump, Demand In is ON when any of its own loaders has a demand.

Alarm Horn Output
LED 23 (J4, Pin 11)

Spare Output
LED 24 (J4, Pin 12)

Motor #4 Running LED
Main Board - LED 7

Motor #3 Running LED
Main Board - LED 6

Motor #2 Running LED
Main Board - LED 5

Motor #1 Running LED
Main Board - LED 4

Run LED
(On Front Panel)

Mixer Full LED
(On Front Panel)

Alarm LED
(On Front Panel)

End of Output Test

Spare Output
LED 26 (J4, Pin 14)

Spare Output
LED 25 (J4, Pin 13)

Demand Out (Pump)
LEDs 9/10 (J5, Pin 1)

Next Loader Output
LED 12 (J5, Pin 4)

Discharge Valve #4
LED 20 (J4, Pin 8)

Discharge Valve #3
LED 19 (J4, Pin 7)

Popper Valve #4
LED 18 (J4, Pin 6)

Popper Valve #3
LED 17 (J4, Pin 5)

Popper Valve #2
LED 16 (J4, Pin 4)

Popper Valve #1
LED 15 (J4, Pin 3)

Discharge Valve #2
LED 14 (J4, Pin 2)

Discharge Valve #1
LED 13 (J4, Pin 1)

Metering Light (AC)
LED 22 (J4, Pin 10)

<SETUP> Access Code 28 - Output Test

*** DIAGNOSTICS***

28 Output Test

Advance to <SETUP> Access Code 28 using the SET Buttons.
Press the DnSelect Button (3B) and the display will read:

OUTPUT TEST

Press UpSet to Start

The Output Test allows the operator to check selected outputs to verify their operation.

CONTROL SUMMARY:

Press the UpSET Button to advance through the outputs listed on the following pages.

Press the DnSet Button to return to previous outputs and scroll backwards through the inputs listed on the following pages.

Press the RUN Button to activate the displayed output.

Press the STOP Button to de-activate the displayed output.

OUTPUT TEST

OUTPUT TEST
Press UpSET to Start

Output Test
All LEDs Off

Metering LED
On Front Panel

Spare Output
LED 21 (J4, Pin 9)

<SETUP> DIAGNOSTICS FUNCTION SUMMARIES

This section explains Diagnostic Functions not discussed in Chapter 6. Please refer to the <SETUP> Diagnostics Menu Listing earlier in this chapter for equivalent Standard Access Codes found in Chapter 6.

<SETUP> Access Code 11 - Use Default Data

```
***DIAGNOSTICS***  
11 Use Default Data
```

Advance to <SETUP> Access Code 11 using the SET Buttons. Press the DnSELECT Button (7B) and the display will read:

```
Press UpSet to Reset  
Default Data
```

Press UpSET Button and display will read:

```
All Data is Reset to  
Default Values
```

Press UpSELECT to exit function and return to <SETUP> Diagnostics Menu. The display will momentarily read:

```
Storing All Data  
Please Wait
```

followed by:

```
***DIAGNOSTICS***  
11 Use Default Data
```

The expected rate setpoint can now be changed using the SET BUTTONS (9A, 9B).

Refer to Chapter 6, Access Code 1 for a full explanation of this function.

Press the UpSELECT Button to exit and return the display to:

DIAGNOSTICS
Access Code - 1

Advance to another Access Code using the SET Buttons.

Exit Diagnostics by pressing the UpSELECT Button.

Control Summary:

1. Press the SET BUTTONS to advance to the desired access code:
DnSET to increase access code.
UpSET to decrease access code.
2. Press the DnSELECT Button to enter the displayed function.
3. Follow the directions for each function as outlined in the next section.
4. Press the UpSELECT Button as needed to exit the function and return to the <SETUP> Diagnostics Menu.
5. Repeat steps 1-4 or press the UpSELECT Button once more to exit Diagnostics and return to the Select Menu.

<SETUP> ACCESS CODE	STD ACCESS CODE	FUNCTION NAME	No. OF SCREENS	DESCRIPTION
✓ 35	—	Watchdog Test	2	Test internal watchdog timer. Disabled on old hardware.
36	955	Spare Function	2	Reserved for future option.
—	354	Spare Function	2	Reserved for future option.

- ★ Function used only in RS-232 applications.
- ✓ Not available with LCD control.
- ▶ Function used only in SPI applications.
- *These functions have five screens if the blender is set up for a fifth component (possible only with Vacuum Fluorescent control).

USING <SETUP> DIAGNOSTICS FUNCTIONS

Enter the blender <SETUP> Mode as outlined in the first section of this manual.

Press the DnSELECT Button to advance to the last Select Menu screen and the display will read:

DIAGNOSTICS

Press Down Set

<SETUP> Diagnostics Functions work the same as their equivalent standard diagnostics functions.

To see an example, press the DnSET Button and the display will read:

DIAGNOSTICS

1 Expected Rate

<SETUP> Access Code	Description
---------------------	-------------

This is the same "Expected Rate" function described earlier in Chapter 6. Press the DnSELECT Button and the display reads:

EXPECTED RATE

0.0 lb/hr

< SETUP > ACCESS CODE	STD ACCESS CODE	FUNCTION NAME	No. OF SCREENS	DESCRIPTION
✓ 18	460	5th Loader	1	5th Loader for analog output ON/OFF.
✓ 19	461	Low Level Sensor	1	Setup Inputs for hopper low level sensors.
20	554	Shaft Speed	4 or 5*	Show actual measured auger speeds in RPM.
21	654	Real-Time Clock	1	Set/View real-time clock used in print out.
22	754	Calibration	1	Perform Volumetric Calibration.
23	755	Calibration Stop Mode	1	Set calibration to stop manually/automatically.
24	756	Edit Calibration Data	4 or 5*	Edit calibration times and weights.
25	757	Hopper Clean Out	4 or 5*	Disable loaders to empty hoppers.
26	854	Mixer Mode	3	Set mixer level program for continuous/cycling mode and set blender master speed and restart time.
27	855	Mixer Sensors	1	Set up machine for one or two Mixer Level Sensors.
28	—	Output Test	27	Test all machine outputs.
29	—	Input Test	32	Test all machine inputs.
30	—	Motor Out Test	2	Individually test motor outputs.
31	—	Jumper Test	1	Test option jumper inputs.
32	—	RAM Test	1	Test Non-Volatile RAM chip(s).
33	—	EEPROM Test	1	Test EEPROM chip. Disabled on old hardware.
34	—	Mixer Status	1	Show mixer timer, status, mfactor, etc. For troubleshooting purposes only.

< SETUP > DIAGNOSTICS MENU LISTING

The following is a list of functions found in the < SETUP > Diagnostics Menu along with their access codes and brief descriptions. Also included are the Standard Access Code equivalents for each < SETUP > Diagnostic Function.

< SETUP > ACCESS CODE	STD ACCESS CODE	FUNCTION NAME	No. OF SCREENS	DESCRIPTION
1	1	Expected Rate	1	Program total machine rate.
2	2	Analog Output	1	Program auxiliary output SP.
* 3	3	Printer Interval	1	Program time interval between printouts.
4	854	English/Metric	1	Choose English/Metric unit of measure.
5	5	Machine Totalizer	1	Total of auger totalizers.
6	6	Clear Totalizers	1	Clear all auger totalizers.
7	7	Auger Alarm Mode	4	Set alarm mode to Shut Down or Alarm Only.
✓ 8	54	Screen Intensity	1	Set V-F Display Brightness. Disabled on LCD hardware.
▷ 9	154	SPI Setup	2	Set Node Address and Baud Rate for SPI Communications
10	254	Mixer Reset Time	1	Time used by mixer level adjustment program.
11	—	Use Default Data	1	Forces all calibration and setup data to default values.
12	454	Load Times	4 or 5*	Maximum Loader "on" times.
13	455	Dump Times	4 or 5*	Discharge Valve open.
14	456	Loader Type	4 or 5*	Selectronic/Integral Motor.
15	457	Load Cycles	4 or 5*	Set number of loader cycles before alarm sounds.
16	458	Control Type	1	Choose external loader control or internal blender control to operate loaders.
17	459	Sensor Type	1	Normally Open/Normally Closed.

< SETUP > ACCESS CODE	STD ACCESS CODE	FUNCTION NAME	No. OF SCREENS	DESCRIPTION
✓ 18	460	5th Loader	1	5th Loader for analog output ON/OFF.
✓ 19	461	Low Level Sensor	1	Setup Inputs for hopper low level sensors.
20	554	Shaft Speed	4 or 5*	Show actual measured auger speeds in RPM.
21	654	Real-Time Clock	1	Set/View real-time clock used in print out.
22	754	Calibration	1	Perform Volumetric Calibration.
23	755	Calibration Stop Mode	1	Set calibration to stop manually/automatically.
24	756	Edit Calibration Data	4 or 5*	Edit calibration times and weights.
25	757	Hopper Clean Out	4 or 5*	Disable loaders to empty hoppers.
26	854	Mixer Mode	3	Set mixer level program for continuous/cycling mode and set blender master speed and restart time.
27	855	Mixer Sensors	1	Set up machine for one or two Mixer Level Sensors.
28	—	Output Test	27	Test all machine outputs.
29	—	Input Test	32	Test all machine inputs.
30	—	Motor Out Test	2	Individually test motor outputs.
31	—	Jumper Test	1	Test option jumper inputs.
32	—	RAM Test	1	Test Non-Volatile RAM chip(s).
33	—	EEPROM Test	1	Test EEPROM chip. Disabled on old hardware.
34	—	Mixer Status	1	Show mixer timer, status, mfactor, etc. For troubleshooting purposes only.

<SETUP> DIAGNOSTICS FUNCTION SUMMARIES

This section explains Diagnostic Functions not discussed in Chapter 6. Please refer to the <SETUP> Diagnostics Menu Listing earlier in this chapter for equivalent Standard Access Codes found in Chapter 6.

<SETUP> Access Code 11 - Use Default Data

```
***DIAGNOSTICS***  
11 Use Default Data
```

Advance to <SETUP> Access Code 11 using the SET Buttons. Press the DnSELECT Button (7B) and the display will read:

```
Press UpSet to Reset  
Default Data
```

Press UpSET Button and display will read:

```
All Data is Reset to  
Default Values
```

Press UpSELECT to exit function and return to <SETUP> Diagnostics Menu. The display will momentarily read:

```
Storing All Data  
Please Wait
```

followed by:

```
***DIAGNOSTICS***  
11 Use Default Data
```

The expected rate setpoint can now be changed using the SET BUTTONS (9A, 9B).

Refer to Chapter 6, Access Code 1 for a full explanation of this function.

Press the UpSELECT Button to exit and return the display to:

DIAGNOSTICS
Access Code - 1

Advance to another Access Code using the SET Buttons.

Exit Diagnostics by pressing the UpSELECT Button.

Control Summary:

1. Press the SET BUTTONS to advance to the desired access code:
DnSET to increase access code.
UpSET to decrease access code.
2. Press the DnSELECT Button to enter the displayed function.
3. Follow the directions for each function as outlined in the next section.
4. Press the UpSELECT Button as needed to exit the function and return to the <SETUP> Diagnostics Menu.
5. Repeat steps 1-4 or press the UpSELECT Button once more to exit Diagnostics and return to the Select Menu.

<SETUP> Access Code 28 - Output Test

*** DIAGNOSTICS***

28 Output Test

Advance to <SETUP> Access Code 28 using the SET Buttons.
Press the DnSelect Button (3B) and the display will read:

OUTPUT TEST

Press UpSet to Start

The Output Test allows the operator to check selected outputs to verify their operation.

CONTROL SUMMARY:

Press the UpSET Button to advance through the outputs listed on the following pages.

Press the DnSet Button to return to previous outputs and scroll backwards through the inputs listed on the following pages.

Press the RUN Button to activate the displayed output.

Press the STOP Button to de-activate the displayed output.

OUTPUT TEST

OUTPUT TEST
Press UpSET to Start

Output Test
All LEDs Off

Metering LED
On Front Panel

Spare Output
LED 21 (J4, Pin 9)

Warranty/Service Information
Parts List
Control Box Assembly
Control Box Wiring Diagram
Terminal Box
Terminal Box Wiring Diagram
Sample RS-232 Print Out

Conair has made the largest investment in customer support in the plastics industry. Our service experts are available to help with any problem you might have installing and operating your equipment. Your Conair sales representative also can help analyze the nature of your problem, assuring that it did not result from misapplication or improper use.

WE'RE HERE TO HELP

To contact Customer Service personnel, call:



HOW TO CONTACT CUSTOMER SERVICE

From outside the United States, call: 814-437-6861

You can commission Conair service personnel to provide on-site service by contacting the Customer Service Department. Standard rates include an on-site hourly rate, with a one-day minimum plus expenses.

If you do have a problem, please complete the following checklist before calling Conair:

- Make sure you have all model, serial and parts list numbers for your particular equipment. Service personnel will need this information to assist you.
- Make sure power is supplied to the equipment.
- Make sure that all connectors and wires within and between loading control and related components have been installed correctly.
- Check the troubleshooting guide of this manual for a solution.
- Thoroughly examine the instruction manual(s) for associated equipment, especially controls. Each manual may have its own troubleshooting guide to help you.
- Check that the equipment has been operated as described in this manual.
- Check accompanying schematic drawings for information on special considerations.

BEFORE YOU CALL ...

Additional manuals and prints for your Conair equipment may be ordered through the Customer Service or Parts Departments for a nominal fee.

EQUIPMENT GUARANTEE

Conair guarantees the machinery and equipment on this order, for a period as defined in the quotation from date of shipment, against defects in material and workmanship under the normal use and service for which it was recommended (except for parts that are typically replaced after normal usage, such as filters, liner plates, etc.). Conair's guarantee is limited to replacing, at our option, the part or parts determined by us to be defective after examination. The customer assumes the cost of transportation of the part or parts to and from the factory.

PERFORMANCE WARRANTY

Conair warrants that this equipment will perform at or above the ratings stated in specific quotations covering the equipment or as detailed in engineering specifications, provided the equipment is applied, installed, operated and maintained in the recommended manner as outlined in our quotation or specifications.

Should performance not meet warranted levels, Conair at its discretion will exercise one of the following options:

- Inspect the equipment and perform alterations or adjustments to satisfy performance claims. (Charges for such inspections and corrections will be waived unless failure to meet warranty is due to misapplication, improper installation, poor maintenance practices or improper operation.)
- Replace the original equipment with other Conair equipment that will meet original performance claims at no extra cost to the customer.
- Refund the invoiced cost to the customer. Credit is subject to prior notice by the customer at which time a Return Goods Authorization Number (RGA) will be issued by Conair's Service Department. Returned equipment must be well crated and in proper operating condition, including all parts. Returns must be prepaid.

Purchaser must notify Conair in writing of any claim and provide a customer receipt and other evidence that a claim is being made.

WARRANTY LIMITATIONS

Except for the Equipment Guarantee and Performance Warranty stated above, Conair disclaims all other warranties with respect to the equipment, express or implied, arising by operation of law, course of dealing, usage of trade or otherwise, including but not limited to the implied warranties of merchantability and fitness for a particular purpose.

SERVICE INFORMATION

WE'RE HERE TO HELP!

Conair Franklin has made the largest investment in Customer Support in the entire industry and our staff of service experts are available to help you in the event of any problem you may encounter in the installation or operation of your equipment.

Your Conair Franklin Sales Representative (who sold the equipment to your company) may be of help in analyzing the exact nature of your problem and assuring that your problem is not the result of misapplication or improper use.

ON SITE SERVICE

Conair Franklin Servicemen may be commissioned to provide on-site service if necessary. Arrangements may be made by contacting the Customer Service Department. Standard rates include an on-site hourly rate with a one day minimum, plus expenses.

BEFORE YOU CALL....

Before calling Conair Franklin in the event of a problem, check the following:

- The troubleshooting guide of this manual.
- Thorough examination of related instruction manual(s) for associated equipment, especially controls. Each manual may have its own troubleshooting guide to help you.
- The complete installation of all connectors and wires within and between control systems and related components.
- Proper power is supplied.
- Proper operation as described in this manual.
- Check accompanying prints for information on special equipment considerations.

Please have available the Model, Serial and Parts List numbers for your particular equipment ready when you call our Customer Service Department.

Additional manuals or prints for your Conair Franklin equipment may be ordered through the Customer Service or Parts Departments for a nominal fee.

CONAIR FRANKLIN SERVICE HOTLINE:

CONAIR FRANKLIN PARTS HOTLINE:

(800) 458-1960

To order parts only, call toll free: (800) 458-1960

Conair Franklin, Franklin, PA 16323 (814)437-6861 Fax: (814)432-6227

Date: <u>5/4/91</u>
Equipment: <u>Conomix Plus (Volumetric Blender)</u>
C Wiring Diagram Number: <u>107-320-01D (RS232)</u> Assembly Number <u>610-009-01</u>
C Terminal Box W.D. No. <u>107-321-01 D</u> Control Assy. No. <u>107-319-01 E</u> C
Instruction Manual Number: <u>IMA-072</u> (RS232)

Ref. No.	Part Number	Qty.	Description
<u>Metering Augers and Sleeves</u>			
C 1.	611-060-15		3/8" OD x 3/8" Pitch Auger (Polished)
C 2.	611-060-16		3/8" OD x 3/8" Pitch Auger (Glass Bead Shot)
3.	611-060-01		1/2" OD x 1/2" Pitch Auger (Polished)
4.	611-060-02		3/4" OD x 3/4" Pitch Auger (Polished)
5.	611-060-03		1" OD x 1" Pitch Auger (Polished)
6.	611-060-04		1-1/2" OD x 1-1/2" Pitch Auger (Polished)
7.	611-060-05		2" OD x 2" Pitch Auger (Polished)
8.	611-060-06		2-1/2" OD x 2-1/2" Pitch Auger (Polished)
9.	611-060-07		3" OD x 3-1/2" Pitch Auger (Polished)
10.	611-060-08		1/2" OD x 1/2" Pitch Auger (Glass Bead Shot)
11.	611-060-09	As Req'd.	3/4" OD x 3/4" Pitch Auger (Glass Bead Shot)
12.	611-060-10	1 Per Hopper	1" OD x 1" Pitch Auger (Glass Bead Shot)
13.	611-060-11		1-1/2" OD x 1-1/2" Pitch Auger (Glass Bead Shot)
14.	611-060-12		2" OD x 2" Pitch Auger (Glass Bead Shot)
15.	611-060-13		2-1/2" OD x 2-1/2" Pitch Auger (Glass Bead Shot)
16.	611-060-14		3" OD x 3" Pitch Auger (Glass Bead Shot)
C 16.	613-012-13		1/2" ID Sleeve
C 17.	613-012-14		3/4" ID Sleeve
18.	613-012-12		5/8" ID Sleeve
19.	613-012-01		7/8" ID Sleeve
20.	613-012-02		1-1/8" ID Sleeve
21.	613-012-03		1-3/8" ID Sleeve
22.	613-012-04		1-5/8" ID Sleeve
23.	613-012-05		1-7/8" ID Sleeve
24.	613-012-06	As Req'd.	2-1/8" ID Sleeve
25.	613-012-07	1 Per Hopper	2-3/8" ID Sleeve
26.	613-012-08		2-5/8" ID Sleeve
27.	613-012-09		2-7/8" ID Sleeve
28.	613-012-10		3-1/8" ID Sleeve
29.	613-012-11		3-3/8" ID Sleeve
30.	613-127	1 Per Hopper	Auger Drive Coupling
31.	299-220-06	1 Per Hopper	Auger Bearing
32.	291-331-07-08	1 Per Hopper	Auger Drive Pin (Req'd. W/Item 27)



Spare Parts List

Ref. No.	Part Number	Qty.	Description
----------	-------------	------	-------------

Fasteners/Hardware

	1.	613-005-02	1 Per Hopper	Auger Sensor Bracket
	2.	613-003-14	3 Per Hopper	5/16-18 NC x 5" Lg. Soc. Head Cap Screw
	3.	291-206-13	3 Per Hopper	Hand Knob Press On (Auger Housing Door)
CC	4.	613-176	1 Per Std. Hpr.	Strip Sight Glass (Hopper)
CC	5.	613-164	1 Per Opt. Hpr.	Strip Sight Glass (Hopper - No door)
	5.	291-206-08	2	Hand Knob 1/4-20 (Mounting)
	6.	299-019-21	2	Spring (Slide gate seal)
	7.	299-019-20	3 Per Hopper	Spring (Motor Mounting Plate Seal)
	8.	299-069	2	Sight Glass (Mixing Chamber)
CC	9.	291-333-01	2	Toggle Clamp
CC	10.	613-163	1 Per Std. Hpr.	Lexan Window - Hopper Door

Control

RE: Drawing Number 107-319-01 E Conomix Plus Control Box Assembly

	1.	107-291-21-01	1	Conomix Plus Control PC Board (RS232)
	2.	107-276-01	1	Gravicon Loader PC Board
	3.	107-252-01	1	Motor PC Board
	4.	107-244-01	1	Display PC Board
	5.	203-018-05	1	Circuit Breaker Switch - 15 Amp
	6.	203-018-09	1	Circuit Breaker Switch - 12 Amp
	7.	209-089-03	1	Audible Alarm - Bell
	8.	107-110-02	1	LCD Display Assembly
	9.	204-023-01-24-08	1	Neon Light - Amber
	10.	204-023-01-22-08	1	Neon Light - Red
	11.	203-037-02	1	Toggle Switch
	12.	209-496-02	1	Transformer 115/230 V. to 24 VAC
	13.	200-004-01	1	Relay DPDT
	14.	108-145-03	1	Fuse 3 Amp
	15.	202-017-03-49-00	7	Pushbutton - Square
	16.	200-007-10	1	Relay - DPDT (Track Mounted)

RE: Drawing Number 107-321-01 A Terminal Box Assembly

	1.	204-014-03	1	Pilotlight - Amber
C	2.	209-341-01	8	MOV

Ref. No.	Part Number	Qty.	Description
----------	-------------	------	-------------

Air

1.	299-240-01	As Req'd.	Vibrator
2.	299-028	As Req'd.	Air Pad, Bindicator BIN-FLO L-SS
3.	292-132-03	As Req'd.	Flow Control Valve
4.	243-001-02	As Req'd.	Filter

Electrical

* 1.	209-597-01	1	Mixing Chamber Sensor
* 2.	209-494-07	1 Per Hopper	Auger Sensor
* 3.	209-525-01	1 Per Hopper	DC Motor, Panasonic, 24VDC, 2.8A, 120 RPM (Auger Drive)
* 4.	209-498-01	1	Mixer Motor 110V., 1 Ph., 60 Hz., 1/2 HP, 10 A.
* 5.	209-358-19	As Req'd.	Hopper Level Bindicator W/7" Paddle - 220 V.
6.	209-160-19	As Req'd.	Hopper Level Bindicator W/7" Paddle - 110 V.
* 7.	209-111-05	As Req'd.	Magnetic Switch, Electric Device EDC-42
* 8.	209-111-06	As Req'd.	Magnetic Actuator, Electric Device EDC-41
9.	108-896-01	As Req'd.	Asco Valve Assembly - 110V. (Air Piping)
10.	209-597-01	As Req'd.	Hopper Level Sensor
11.	107-319-01	1	Conomix Plus Control Box Assembly (RS232)
12.	107-321-01	1	Terminal Box Assembly

Mixer Drive (SM-Cyclo)

1.	612-013-06	1	Agitator (Conomix Plus)
2.	612-045-01	1	Threaded Coupling
3.	291-123-01	1	Roll Pin, 1/4" x 1-3/4" Lg.
4.	**290-441-02	1	Speed Reducer W/Holes, 35 to 1 Ratio, 50 RPM Output

(** modified per 613-011-03)

Gaskets and Seals

1.	613-004-04	1 Per Hopper	Hopper Flange - Auger Housing Gasket
2.	613-004-02	1 Per Hopper	Auger Housing Mounting Flange Gasket
3.	613-004-07	1 Per Hopper	Auger Housing Motor Plate Seal
4.	613-004-05	1	Slide Gate Gasket
5.	613-004-06	1	Slide Gate Adapter Gasket
6.	613-045-06	1 Per Hopper	Calibration Chute Slide Seal
7.	104-161-01	As Req'd.	Lid Seal Gasket (Hand fill or Filter sock lid)
8.	613-004-08	As Req'd.	Filter Sock (Filter sock lid)
9.	259-071-05	1	Sensor "O" Ring (Mixing Chamber)
10.	199-011-84	1 Per Hopper	Calibration Chute Plug
11.	259-143-17-01	1 Per Hopper	"O" Ring (Auger Drive)
12.	613-045-03	As Req'd.	14-1/2" x 28" (3 Cu.Ft.) Hopper Gasket
13.	613-004-02	As Req'd.	Block Off Kit Gasket

CONAIR
FRANKLIN

Spare Parts List

Ref. No.	Part Number	Qty.	Description
RE: Drawing Number 614-016 A Low Level Visual & Audible Alarm Assembly (Reference numbers match item numbers on drawing)			
5.	204-001-05	1	60 Watt Rough Service Bulb
13.	204-001-01	1	Neon Bulb (NE51H)
RE: Drawing Number 614-017 A Electrical Parts for Audible & Visual Alarm (Reference numbers match item numbers on drawing)			
1.	206-006-02	1	Fuse 2 Amp
2.	203-001-02	1	Switch
3.	204-002-03	1	Pilotlight
4.	209-092-01	1	Alarm Light - Killark
5.	209-214	1	Horn - Edwards
6.	202-001-02	1	Pushbutton
7.	200-004-01	2	Relay

* Indicates recommended spare parts

MINIMUM ORDER: \$50.00 (Due to cost of handling)

ITEM NUMBER REQUIRED	PART NUMBER	DESCRIPTION
56	8-32NC X 3/8 RD HD MACH SCREW	ENCLOSURE VELDMENT
57	1/4-20NC X 3/8 RD HD MACH SCREW	PANEL DETAIL
58	10-32NF X 3/8 RD HD MACH SCREW	LABEL
59	3/8-16NC HEX NUT	CONDMIX PLUS CONTROL P.C. BOARD
60	3/8 FLAT WASHER	CONDMIX PLUS LABEL
61	912-187-85-03	GRAY/IDM LDRNR P.C. BOARD
62	506-007-03	SHLD. FRM LDRNR P.C. BOARD
63	509-062-05	GRAY/IDM MOTOR P.C. BOARD
64	912-187-85-04	DISPLAY P.C. BOARD
65	899-874-05-04	LCD DISPLAY ASSEMBLY
11	203-018-05	CIRCUIT BREAKER SWITCH - 15 AMP
12	209-089-03	AUDIO ALARM - BELL
13	209-089-03	AUDIO ALARM - BELL
14	209-010-07	HOLE PLUG
15	205-008-03	CORD SET 14-3 S.J.
16	200-004-01	RELAY - DPDT OCTALS
17	209-070-01	RELAY SOCKET OCTALS
18	209-486-02	TRANSFORMER - SIGNAL #BL-24-12
19	803-037-08	TOGGLE SWITCH
20	108-145-03	FUSE (3A) LITTELFUSE
21	209-082-17	FUSE HOLDER - LITTELFUSE #500359
22	299-153-41-02	LABEL - CONNECTOR
23	299-153-42-02	LABEL - PDVER
24	204-023-01-24-08	NEON LIGHT - AMBER
25	204-023-01-22-08	NEON LIGHT - RED
26	207-001-10	CORD GRIP
27	207-001-08	CORD GRIP
28	209-001-01	CONDUIT LOCKNUT
29	107-157-01	SEL. TV MALE CONNECTOR SET 10 FT
30	107-157-02	SEL. TV FEMALE CONNECT. SET 10 FT
31	434-092	TERMINAL STRIP LABEL
32	209-290-01	GROUND LUG
33	857-100-09	1/4 INTERNAL TOOTH LOCKWASHER
34	209-007-17	TERMINAL STRIP - 17 LUG
35	SEE CHART	CONTROL CABLE/TWISTED PAIR
36	208-043-18	RECEPTACLE - 9 PIN
37	219-053-01	JACK SCREW #4-40NC X 3/16' HEX
38	208-051-06	CONNECTOR - 6 PIN 100 SPACING
39	208-052-02	RECEPTACLE SOCKET
40	899-149-11	1/8 X 3/4 WEATHERSTRIP
41	912-187-85-01	LABEL - ALARM
42	208-014-29	CONNECTOR - 10 PIN AMPHENOL
43	208-014-16	CONNECTOR - 16 PIN AMPHENOL
44	208-014-19	CONNECTOR - 20 PIN AMPHENOL
45	188-406-05	POWER LINE FILTER AND MOV ASH
46	202-017-03-49-00	PUSHBUTTON - SQUARE
47	912-187-85-02	LABEL - SELECT
48	209-543-01-02	#6 CLEAR. X 1/4 LG NYLON SPACER
49	209-543-04-05	6-32NC THD. X 3/4 NYLON SPACER
50	217-600-83	6-32NC X 1-1/2 RD HD NYLON SCREW
51	221-001-07	6-32NC NYLON HEX NUT
52	210-149-02	4-40NC X 5/16 RD HD MACH SCREW
53	221-021-02	4-40NC HEX NUT
54	210-008-06	6-32NC X 3/8 RD HD MACH SCREW
55	210-009-02	6-32NC X 3/4 RD HD MACH SCREW

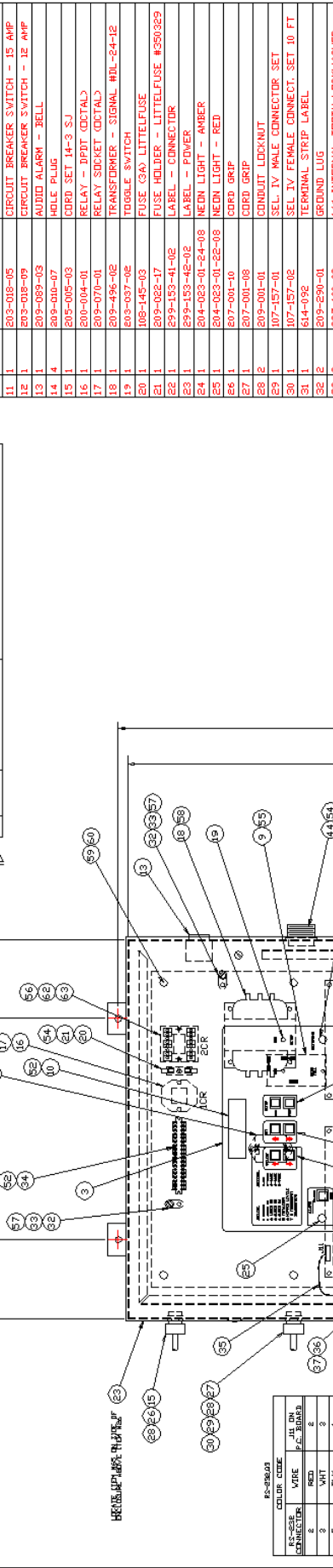

ITEM NUMBER	DESCRIPTION
1	ENCLOSURE VELDMENT
2	PANEL DETAIL
3	LABEL
4	CONDMIX PLUS CONTROL P.C. BOARD
5	CONDMIX PLUS LABEL
6	GRAY/IDM LDRNR P.C. BOARD
7	SHLD. FRM LDRNR P.C. BOARD
8	GRAY/IDM MOTOR P.C. BOARD
9	DISPLAY P.C. BOARD
10	LCD DISPLAY ASSEMBLY
11	CIRCUIT BREAKER SWITCH - 15 AMP
12	AUDIO ALARM - BELL
13	AUDIO ALARM - BELL
14	HOLE PLUG
15	CORD SET 14-3 S.J.
16	RELAY - DPDT OCTALS
17	RELAY SOCKET OCTALS
18	TRANSFORMER - SIGNAL #BL-24-12
19	TOGGLE SWITCH
20	FUSE (3A) LITTELFUSE
21	FUSE HOLDER - LITTELFUSE #500359
22	LABEL - CONNECTOR
23	LABEL - PDVER
24	NEON LIGHT - AMBER
25	NEON LIGHT - RED
26	CORD GRIP
27	CORD GRIP
28	CONDUIT LOCKNUT
29	SEL. TV MALE CONNECTOR SET 10 FT
30	SEL. TV FEMALE CONNECT. SET 10 FT
31	TERMINAL STRIP LABEL
32	GROUND LUG
33	1/4 INTERNAL TOOTH LOCKWASHER
34	TERMINAL STRIP - 17 LUG
35	CONTROL CABLE/TWISTED PAIR
36	RECEPTACLE - 9 PIN
37	JACK SCREW #4-40NC X 3/16' HEX
38	CONNECTOR - 6 PIN 100 SPACING
39	RECEPTACLE SOCKET
40	1/8 X 3/4 WEATHERSTRIP
41	LABEL - ALARM
42	CONNECTOR - 10 PIN AMPHENOL
43	CONNECTOR - 16 PIN AMPHENOL
44	CONNECTOR - 20 PIN AMPHENOL
45	POWER LINE FILTER AND MOV ASH
46	PUSHBUTTON - SQUARE
47	LABEL - SELECT
48	#6 CLEAR. X 1/4 LG NYLON SPACER
49	6-32NC THD. X 3/4 NYLON SPACER
50	6-32NC X 1-1/2 RD HD NYLON SCREW
51	6-32NC NYLON HEX NUT
52	4-40NC X 5/16 RD HD MACH SCREW
53	4-40NC HEX NUT
54	6-32NC X 3/8 RD HD MACH SCREW
55	6-32NC X 3/4 RD HD MACH SCREW

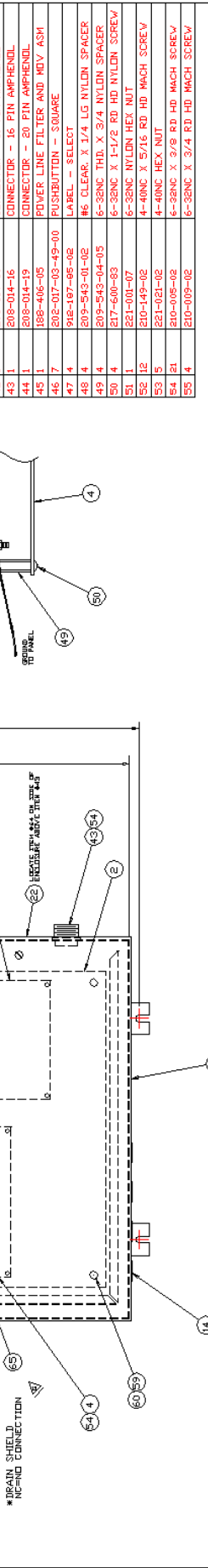

ITEM NUMBER	DESCRIPTION
1	ENCLOSURE VELDMENT
2	PANEL DETAIL
3	LABEL
4	CONDMIX PLUS CONTROL P.C. BOARD
5	CONDMIX PLUS LABEL
6	GRAY/IDM LDRNR P.C. BOARD
7	SHLD. FRM LDRNR P.C. BOARD
8	GRAY/IDM MOTOR P.C. BOARD
9	DISPLAY P.C. BOARD
10	LCD DISPLAY ASSEMBLY
11	CIRCUIT BREAKER SWITCH - 15 AMP
12	AUDIO ALARM - BELL
13	AUDIO ALARM - BELL
14	HOLE PLUG
15	CORD SET 14-3 S.J.
16	RELAY - DPDT OCTALS
17	RELAY SOCKET OCTALS
18	TRANSFORMER - SIGNAL #BL-24-12
19	TOGGLE SWITCH
20	FUSE (3A) LITTELFUSE
21	FUSE HOLDER - LITTELFUSE #500359
22	LABEL - CONNECTOR
23	LABEL - PDVER
24	NEON LIGHT - AMBER
25	NEON LIGHT - RED
26	CORD GRIP
27	CORD GRIP
28	CONDUIT LOCKNUT
29	SEL. TV MALE CONNECTOR SET 10 FT
30	SEL. TV FEMALE CONNECT. SET 10 FT
31	TERMINAL STRIP LABEL
32	GROUND LUG
33	1/4 INTERNAL TOOTH LOCKWASHER
34	TERMINAL STRIP - 17 LUG
35	CONTROL CABLE/TWISTED PAIR
36	RECEPTACLE - 9 PIN
37	JACK SCREW #4-40NC X 3/16' HEX
38	CONNECTOR - 6 PIN 100 SPACING
39	RECEPTACLE SOCKET
40	1/8 X 3/4 WEATHERSTRIP
41	LABEL - ALARM
42	CONNECTOR - 10 PIN AMPHENOL
43	CONNECTOR - 16 PIN AMPHENOL
44	CONNECTOR - 20 PIN AMPHENOL
45	POWER LINE FILTER AND MOV ASH
46	PUSHBUTTON - SQUARE
47	LABEL - SELECT
48	#6 CLEAR. X 1/4 LG NYLON SPACER
49	6-32NC THD. X 3/4 NYLON SPACER
50	6-32NC X 1-1/2 RD HD NYLON SCREW
51	6-32NC NYLON HEX NUT
52	4-40NC X 5/16 RD HD MACH SCREW
53	4-40NC HEX NUT
54	6-32NC X 3/8 RD HD MACH SCREW
55	6-32NC X 3/4 RD HD MACH SCREW

ITEM NUMBER	DESCRIPTION
1	ENCLOSURE VELDMENT
2	PANEL DETAIL
3	LABEL
4	CONDMIX PLUS CONTROL P.C. BOARD
5	CONDMIX PLUS LABEL
6	GRAY/IDM LDRNR P.C. BOARD
7	SHLD. FRM LDRNR P.C. BOARD
8	GRAY/IDM MOTOR P.C. BOARD
9	DISPLAY P.C. BOARD
10	LCD DISPLAY ASSEMBLY
11	CIRCUIT BREAKER SWITCH - 15 AMP
12	AUDIO ALARM - BELL
13	AUDIO ALARM - BELL
14	HOLE PLUG
15	CORD SET 14-3 S.J.
16	RELAY - DPDT OCTALS
17	RELAY SOCKET OCTALS
18	TRANSFORMER - SIGNAL #BL-24-12
19	TOGGLE SWITCH
20	FUSE (3A) LITTELFUSE
21	FUSE HOLDER - LITTELFUSE #500359
22	LABEL - CONNECTOR
23	LABEL - PDVER
24	NEON LIGHT - AMBER
25	NEON LIGHT - RED
26	CORD GRIP
27	CORD GRIP
28	CONDUIT LOCKNUT
29	SEL. TV MALE CONNECTOR SET 10 FT
30	SEL. TV FEMALE CONNECT. SET 10 FT
31	TERMINAL STRIP LABEL
32	GROUND LUG
33	1/4 INTERNAL TOOTH LOCKWASHER
34	TERMINAL STRIP - 17 LUG
35	CONTROL CABLE/TWISTED PAIR
36	RECEPTACLE - 9 PIN
37	JACK SCREW #4-40NC X 3/16' HEX
38	CONNECTOR - 6 PIN 100 SPACING
39	RECEPTACLE SOCKET
40	1/8 X 3/4 WEATHERSTRIP
41	LABEL - ALARM
42	CONNECTOR - 10 PIN AMPHENOL
43	CONNECTOR - 16 PIN AMPHENOL
44	CONNECTOR - 20 PIN AMPHENOL
45	POWER LINE FILTER AND MOV ASH
46	PUSHBUTTON - SQUARE
47	LABEL - SELECT
48	#6 CLEAR. X 1/4 LG NYLON SPACER
49	6-32NC THD. X 3/4 NYLON SPACER
50	6-32NC X 1-1/2 RD HD NYLON SCREW
51	6-32NC NYLON HEX NUT
52	4-40NC X 5/16 RD HD MACH SCREW
53	4-40NC HEX NUT
54	6-32NC X 3/8 RD HD MACH SCREW
55	6-32NC X 3/4 RD HD MACH SCREW

ITEM NUMBER	DESCRIPTION
1	ENCLOSURE VELDMENT
2	PANEL DETAIL
3	LABEL
4	CONDMIX PLUS CONTROL P.C. BOARD
5	CONDMIX PLUS LABEL
6	GRAY/IDM LDRNR P.C. BOARD
7	SHLD. FRM LDRNR P.C. BOARD
8	GRAY/IDM MOTOR P.C. BOARD
9	DISPLAY P.C. BOARD
10	LCD DISPLAY ASSEMBLY
11	CIRCUIT BREAKER SWITCH - 15 AMP
12	AUDIO ALARM - BELL
13	AUDIO ALARM - BELL
14	HOLE PLUG
15	CORD SET 14-3 S.J.
16	RELAY - DPDT OCTALS
17	RELAY SOCKET OCTALS
18	TRANSFORMER - SIGNAL #BL-24-12
19	TOGGLE SWITCH
20	FUSE (3A) LITTELFUSE
21	FUSE HOLDER - LITTELFUSE #500359
22	LABEL - CONNECTOR
23	LABEL - PDVER
24	NEON LIGHT - AMBER
25	NEON LIGHT - RED
26	CORD GRIP
27	CORD GRIP
28	CONDUIT LOCKNUT
29	SEL. TV MALE CONNECTOR SET 10 FT
30	SEL. TV FEMALE CONNECT. SET 10 FT
31	TERMINAL STRIP LABEL
32	GROUND LUG
33	1/4 INTERNAL TOOTH LOCKWASHER
34	TERMINAL STRIP - 17 LUG
35	CONTROL CABLE/TWISTED PAIR
36	RECEPTACLE - 9 PIN
37	JACK SCREW #4-40NC X 3/16' HEX
38	CONNECTOR - 6 PIN 100 SPACING
39	RECEPTACLE SOCKET
40	1/8 X 3/4 WEATHERSTRIP
41	LABEL - ALARM
42	CONNECTOR - 10 PIN AMPHENOL
43	CONNECTOR - 16 PIN AMPHENOL
44	CONNECTOR - 20 PIN AMPHENOL
45	POWER LINE FILTER AND MOV ASH
46	PUSHBUTTON - SQUARE
47	LABEL - SELECT
48	#6 CLEAR. X 1/4 LG NYLON SPACER
49	6-32NC THD. X 3/4 NYLON SPACER
50	6-32NC X 1-1/2 RD HD NYLON SCREW
51	6-32NC NYLON HEX NUT
52	4-40NC X 5/16 RD HD MACH SCREW
53	4-40NC HEX NUT
54	6-32NC X 3/8 RD HD MACH SCREW
55	6-32NC X 3/4 RD HD MACH SCREW

ITEM NUMBER	DESCRIPTION
1	ENCLOSURE VELDMENT
2	PANEL DETAIL
3	LABEL
4	CONDMIX PLUS CONTROL P.C. BOARD
5	CONDMIX PLUS LABEL
6	GRAY/IDM LDRNR P.C. BOARD
7	SHLD. FRM LDRNR P.C. BOARD
8	GRAY/IDM MOTOR P.C. BOARD
9	DISPLAY P.C. BOARD
10	LCD DISPLAY ASSEMBLY
11	CIRCUIT BREAKER SWITCH - 15 AMP
12	AUDIO ALARM - BELL
13	AUDIO ALARM - BELL
14	HOLE PLUG
15	CORD SET 14-3 S.J.
16	RELAY - DPDT OCTALS
17	RELAY SOCKET OCTALS
18	TRANSFORMER - SIGNAL #BL-24-12
19	TOGGLE SWITCH
20	FUSE (3A) LITTELFUSE
21	FUSE HOLDER - LITTELFUSE #500359
22	LABEL - CONNECTOR
23	LABEL - PDVER
24	NEON LIGHT - AMBER
25	NEON LIGHT - RED
26	CORD GRIP
27	CORD GRIP
28	CONDUIT LOCKNUT
29	SEL. TV MALE CONNECTOR SET 10 FT
30	SEL. TV FEMALE CONNECT. SET 10 FT
31	TERMINAL STRIP LABEL
32	GROUND LUG
33	1/4 INTERNAL TOOTH LOCKWASHER
34	TERMINAL STRIP - 17 LUG
35	CONTROL CABLE/TWISTED PAIR
36	RECEPTACLE - 9 PIN
37	JACK SCREW #4-40NC X 3/16' HEX
38	CONNECTOR - 6 PIN 100 SPACING
39	RECEPTACLE SOCKET
40	1/8 X 3/4 WEATHERSTRIP
41	LABEL - ALARM
42	CONNECTOR - 10 PIN AMPHENOL
43	CONNECTOR - 16 PIN AMPHENOL
44	CONNECTOR - 20 PIN AMPHENOL
45	POWER LINE FILTER AND MOV ASH
46	PUSHBUTTON - SQUARE
47	LABEL - SELECT
48	#6 CLEAR. X 1/4 LG NYLON SPACER
49	6-32NC THD. X 3/4 NYLON SPACER
50	6-32NC X 1-1/2 RD HD NYLON SCREW
51	6-32NC NYLON HEX NUT
52	4-40NC X 5/16 RD HD MACH SCREW
53	4-40NC HEX NUT
54	6-32NC X 3/8 RD HD MACH SCREW
55	6-32NC X 3/4 RD HD MACH SCREW

ITEM NUMBER	DESCRIPTION
1	ENCLOSURE VELDMENT
2	PANEL DETAIL
3	LABEL
4	CONDMIX PLUS CONTROL P.C. BOARD
5	CONDMIX PLUS LABEL
6	GRAY/IDM LDRNR P.C. BOARD
7	SHLD. FRM LDRNR P.C. BOARD
8	GRAY/IDM MOTOR P.C. BOARD
9	DISPLAY P.C. BOARD
10	LCD DISPLAY ASSEMBLY
11	CIRCUIT BREAKER SWITCH - 15 AMP
12	AUDIO ALARM - BELL
13	AUDIO ALARM - BELL
14	HOLE PLUG
15	CORD SET 14-3 S.J.
16	RELAY - DPDT OCTALS
17	RELAY SOCKET OCTALS
18	TRANSFORMER - SIGNAL #BL-24-12
19	TOGGLE SWITCH
20	FUSE (3A) LITTELFUSE
21	FUSE HOLDER - LITTELFUSE #500359
22	LABEL - CONNECTOR
23	LABEL - PDVER
24	NEON LIGHT - AMBER
25	NEON LIGHT - RED
26	CORD GRIP
27	CORD GRIP
28	CONDUIT LOCKNUT
29	SEL. TV MALE CONNECTOR SET 10 FT
30	SEL. TV FEMALE CONNECT. SET 10 FT
31	TERMINAL STRIP LABEL
32	GROUND LUG
33	1/4 INTERNAL TOOTH LOCKWASHER
34	TERMINAL STRIP - 17 LUG
35	CONTROL CABLE/TWISTED PAIR
36	RECEPTACLE - 9 PIN
37	JACK SCREW #4-40NC X 3/16' HEX
38	CONNECTOR - 6 PIN 100 SPACING
39	RECEPTACLE SOCKET
40	1/8 X 3/4 WEATHERSTRIP
41	LABEL - ALARM
42	CONNECTOR - 10 PIN AMPHENOL
43	CONNECTOR - 16 PIN AMPHENOL
44	CONNECTOR - 20 PIN AMPHENOL
45	POWER LINE FILTER AND MOV ASH
46	PUSHBUTTON - SQUARE
47	LABEL - SELECT
48	#6 CLEAR. X 1/4 LG NYLON SPACER
49	6-32NC THD. X 3/4 NYLON SPACER
50	6-32NC X 1-1/2 RD HD NYLON SCREW
51	6-32NC NYLON HEX NUT
52	4-40NC X 5/16 RD HD MACH SCREW
53	4-40NC HEX NUT
54	6-32NC X 3/8 RD HD MACH SCREW
55	6-32NC X 3/4 RD HD MACH SCREW

ITEM NUMBER	DESCRIPTION
1	ENCLOSURE VELDMENT
2	PANEL DETAIL
3	LABEL
4	CONDMIX PLUS CONTROL P.C. BOARD
5	CONDMIX PLUS LABEL
6	GRAY/IDM LDRNR P.C. BOARD
7	SHLD. FRM LDRNR P.C. BOARD
8	GRAY/IDM MOTOR P.C. BOARD
9	DISPLAY P.C. BOARD
10	LCD DISPLAY ASSEMBLY
11	CIRCUIT BREAKER SWITCH - 15 AMP
12	AUDIO ALARM - BELL
13	AUDIO ALARM - BELL
14	HOLE PLUG
15	CORD SET 14-3 S.J.
16	RELAY - DPDT OCTALS
17	RELAY SOCKET OCTALS
18	TRANSFORMER - SIGNAL #BL-24-12
19	TOGGLE SWITCH
20	FUSE (3A) LITTELFUSE
21	FUSE HOLDER - LITTELFUSE #500359
22	LABEL - CONNECTOR
23	LABEL - PDVER
24	NEON LIGHT - AMBER
25	NEON LIGHT - RED
26	CORD GRIP
27	CORD GRIP
28	CONDUIT LOCKNUT
29	SEL. TV MALE CONNECTOR SET 10 FT
30	SEL. TV FEMALE CONNECT. SET 10 FT
31	TERMINAL STRIP LABEL
32	GROUND LUG
33	1/4 INTERNAL TOOTH LOCKWASHER
34	TERMINAL STRIP - 17 LUG
35	CONTROL CABLE/TWISTED PAIR
36	RECEPTACLE - 9 PIN
37	JACK SCREW #4-40NC X 3/16' HEX</