

USERGUIDE

IMB-100-93 9/94

Selectronic 4+ Loading System Control



WARNING - Reliance on this Manual Could Result in Severe Bodily Injury or Death!

This manual is out-of-date and is provided only for its technical information, data and capacities. Portions of this manual detailing procedures or precautions in the operation, inspection, maintenance and repair of the product forming the subject matter of this manual may be inadequate, inaccurate, and/or incomplete and cannot be used, followed, or relied upon. Contact Conair at info@conairgroup.com or 1-800-654-6661 for more current information, warnings, and materials about more recent product manuals containing warnings, information, precautions, and procedures that may be more adequate than those contained in this out-of-date manual.

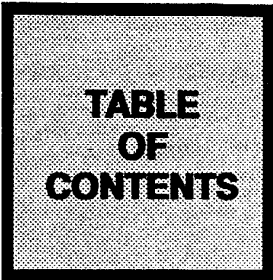

TABLE OF CONTENTS

SELECTRONIC 4+ LOADING SYTEM

SECTION 1

DESCRIPTION PAGE 1

SECTION 2

INSTALLATION PAGE 9

SECTION 3

OPERATION PAGE 11

SECTION 4

TROUBLE SHOOTING PAGE 19

DESCRIPTION

DESCRIPTION

The Selectronic 4+ Conveying System has one pump which provides vacuum conveying power to a number of loading stations in the system. Each loader in the system has an individual control box to provide the proper loading cycle and to sense when material is needed at the station. These individual control boxes are wired together in a "Series" configuration to allow loading of one unit at a time - in sequence. The pump control enclosure is the first in the series and directs power, through multi-conductor cable, to the individual station control enclosures. (See Figure 1). Please refer to the manual(s) for the particular type(s) of loader in your system.

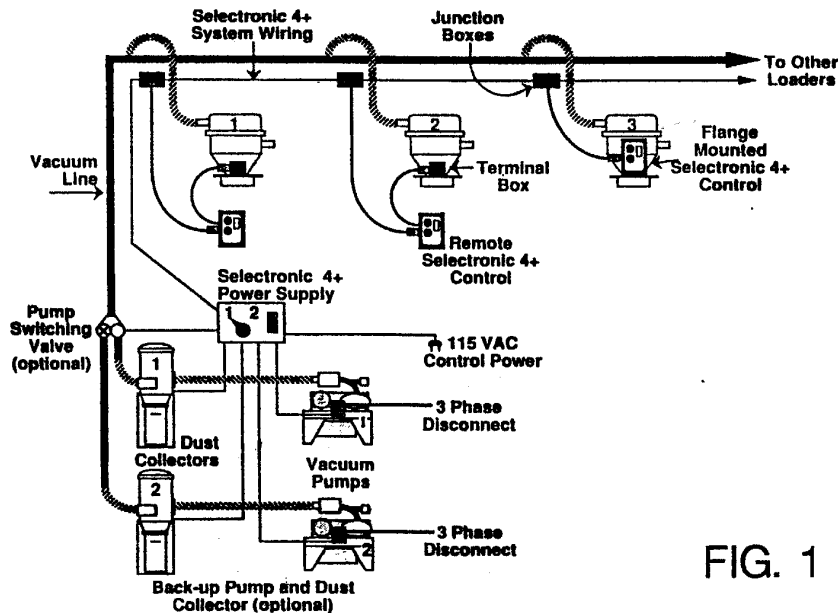

FIG. 1

A Selectronic 4+ System can include several different types of loaders (single material pellet loader, ratio loader, Autocolor, powder loader, etc.). The loader controls are tied together using plug and socket assemblies, connecting the controls to the control cable. Loaders may be interchanged or removed from the system with no system modifications (the maximum number of units on one vacuum pump is determined by conveying rate requirements).

SECTION

1

DESCRIPTION

CONTROL DESCRIPTION

A Selectronic 4+ Loading System is composed of the following electrical components:

- Pump Control (Selectronic Power Supply) located near the vacuum pump
- Eight Conductor Cable (connected from loading station to loading station starting at the pump control)
- Junction Boxes (Customer supplied electrical tie-in points for the loader and the eight conductor cable)

Plus one or more of the following loaders operated by their own control:

- Single Tube Pellet Loader
- Ratio Pellet Loader
- Single Tube Powder Loader (Gemini)
- Ratio Powder Loader
- Autocolor Loader (Includes adapter box to electrically interface with Selectronic 4+)

Pump Control

The pump control performs several functions: 115 volt power for the system; ON/OFF control of the entire loading system; and circuit protection. The dust collector for the vacuum line also electrically connects to this control.

DESCRIPTION

STATION CONTROLS

All Selectronic 4+ controls supplied with Conair loading equipment utilize the same microprocessor printed circuit board. This board is modified through the use of switches located on the circuit board and auxiliary components to perform the specific functions necessary for each type of loader. The following paragraphs describe the operation of the different types of loaders available for your loading system.

Single Tube Loader

This loader provides simple pellet loading into the hopper and automatically cycles the vacuum signal according to the load time set on the control. Unload time for the loader is set with pot 1 on the microprocessor board, and the loader will continue to cycle until the discharge valve level switch indicates that the receiving hopper beneath the loader is full.

Ratio Loader

Selectronic 4+ Controls will load regrind first then virgin. To avoid loading all regrind on start-up adjust ratio percentage before loading. This loader is equipped with a ratio mixing valve which allows the loading of two materials (virgin and regrind), into the vacuum hopper. The control is equipped with a second pot on the control face that determines the percentage of regrind load time desired in the load cycle. The ratio valve will alternate between virgin (left) and regrind (right) during the vacuum cycle to provide some pre-mixing. The rate at which the valve alternates is set with pot 2, located on the PC board within the control.

DESCRIPTION**Single Tube Powder Loader**

This control is provided with a signal from the capacitance load sensor in the vacuum hopper to determine when the loader is full. This sensor, when tripped, terminates the vacuum cycle for that loader, and passes the signal on to the next loader. In this application, the load time control pot acts as an override timer that terminates the load cycle if the sensor is not tripped within the time period set on the control. A vibrator is provided on the vacuum hopper to aid in material flow during unloading. Operation of this vibrator is a function of the unload time, pot 1, on the PC board.

Ratio Powder Loader

This loader is equipped with a ratio mixing valve that alternates between virgin (left) and regrind (right) during the load cycle in order to pre-mix the two materials. The load time control acts as an override timer to pass on the vacuum signal if the material in the vacuum hopper does not trip the load sensor before the time set on the load pot. The regrind control pot sets the desired percentage of regrind load time in relation to the time set on the overall load time pot. Valve cycling is determined by pot 2 on the PC board within the control.

Unit Control Adapter:

(For use with Conair Autocolor) (See Figure 2, Page 5)

This adapter box is provided to permit the installation of an Autocolor into a Selectronic 4+ Loading System. The Autocolor operates from its own remote control enclosure, and determines load and unload times according to its own programmed cycle, independent of the Selectronic Loading System. The unit control adapter receives the load demand from the Autocolor and converts it into a signal for the Selectronic System, to direct vacuum power to the Autocolor.

DESCRIPTION

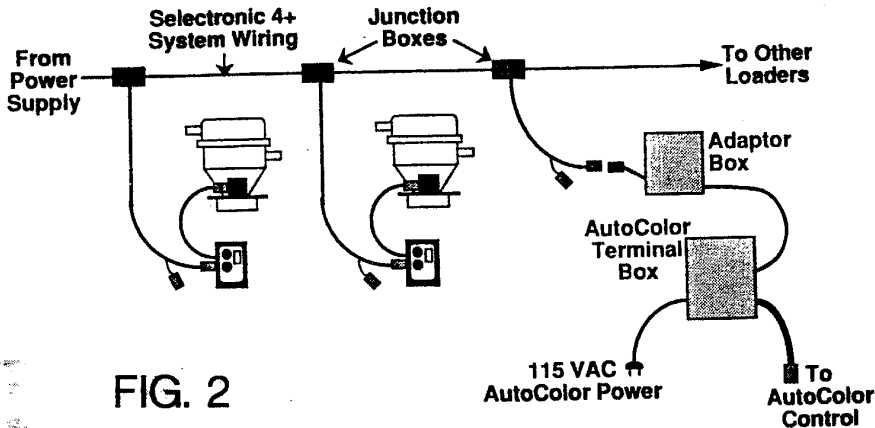

FIG. 2

Selectronic 2 to Selectronic 4+ Unit Control Adapters:
(See Figure 3)

In order to permit newer-style Selectronic 4+ Loaders to work within existing Selectronic 2 Systems, an adapter box can be provided. This adapter converts the 110 volt control signals of the Selectronic 2 System into the lower, 12 VDC signals of Selectronic 4+ Loaders. The adapter box is provided with a multi-pin connector that matches the Selectronic 2 System. This adapter box (See Figure 3) is connected in place of the jumper plug, on the last Selectronic 2 Loader in your system. A junction box, described in "Installation", can then be wired in, from this adapter. This will permit adding a number of Selectronic 4+ Loaders onto your system.

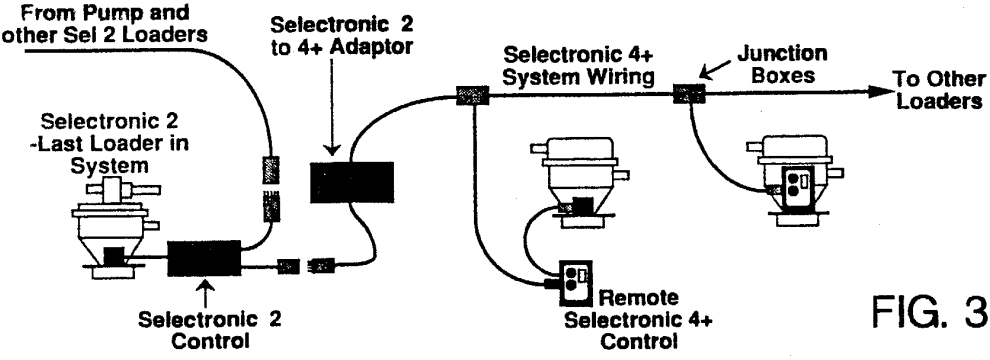

FIG. 3

DESCRIPTION**SELECTRONIC 4+ CONTROL SYSTEM ACCESSORIES****Remote Control Enclosures**

All Selectronic 4+ control enclosures may be mounted remotely with the addition of an extension cable (Available in 10', 15', or 20' lengths). This is highly recommended for loaders used on drying hoppers to prevent the high heat conditions from damaging the electronics of the control. A small terminal box is provided on the loader flange to distribute cables, necessary for loader operation, and to receive the multi-conductor cable, coming from the remote control. Electrical connection to the Selectronic System is performed at the remote control enclosure.

Cabling Junction Box and Connector Cable:

(See Figure 4, Page 7)

To simplify installation of Selectronic 4+ Loading System, a Cabling Junction Box is recommended in close proximity to each loading station. This box provides a tie-in point for the 8 conductor cable coming from upstream loaders, going to downstream loaders, and tying into the loader control via the system connector cable. The junction box may be purchased locally, or provided by any electrical contractor. Color coding is explained in Figure 4. The connector cable provides a singular connection between the loader control and the junction box. The control end of this cable is equipped with the multi-pin connector matching that of the control.

SECTION**1****DESCRIPTION****Station By-Pass Jumper Plug** (See Figure 4, Page 7)

In the event of a problem, or when working on a particular loading station that requires electrical disconnection of power, a jumper may be installed in place of the loader. This jumper, plugged into the connector cable, provides necessary circuit continuity past the loading station when the control is disconnected. Stations may be removed from the system without interfering with the normal operation of remaining loaders with the jumper.

NOTE: The jumper is not needed if the loading station removed from the system is last in the Selectronic line. The by-pass jumper is attached to the station connector cable, shipped with each loader.

INSTALLATION

ELECTRICAL SYSTEM INSTALLATION

The Selectronic 4+ System includes a central vacuum source coupled to a number of loaders. The entire system is operated by the individual control boxes at each loader. As shown in Figures 1 and 4, each loader control is connected to the series wiring using junction boxes and connector cables.

System Wiring

Standard installation consists of mounting the cabling junction boxes near each loader. Eight conductor shielded cable is then connected in and out of these boxes, starting at the pump control, going to station 1, then 2, etc.. (See Figure 1). If local electrical codes permit, the cable can be tie-wrapped to the vacuum line (See "Vacuum Tubing Installation", below). The connector cables, with their multi-pin connectors are then installed from the junction boxes to the loader controls.

Power to the loaders in the system is supplied by this eight conductor, 18 gauge cable, which runs from the selectronic power supply through each loading station junction box, in a series configuration. It should be noted that both 110 VAC and 12 VDC power travels through this cable. Wiring should be performed by a competent electrician and double checked with a volt-ohm meter for continuity, ground, and short circuits. Should the 110V power accidentally contact a 12V conductor, damage to the microprocessor(s) could result.

IMPORTANT: At the system cabling junction box; be sure to connect the brown wire **from** the first loader to the blue wire of the second loader. Connect the brown wire **from** the second loader to the blue wire of the third loader, and so on. Continue this sequence of wiring to the final loader in the system. (See Figure 4, Page 7).

INSTALLATION**Selectronic Power Supply**

Power for the system is connected into this enclosure (See Figure 1). The control power for the system is 110 volt, 60 Hz, single-phase (hot, neutral, and ground). **Be sure the polarity of the control power source is correct (the "hot" leg must pass through 5 Amp Circuit Breaker).**

Three-phase power for the operation of the pump motor is connected to the starter located on the vacuum pump; see the pump nameplate for voltage, and size your 3-phase power accordingly. A wall-mounted disconnect switch with fuses should be installed to provide electrical isolation. Observe all local electrical codes.

Connection should also be made to the dust collector solenoid valve with the cable provided on the dust collector. The collector is wired into the Selectronic power supply box so that whenever the pump is energized, the popper valve in the collector opens to vacuum.

After wiring installation is completed, the loader controls are connected to the system by plugging the multi-pin connectors on the controls into their mating connectors, coming from the junction boxes (See Figure 4, Page 7).

OPERATION**START-UP, MOTOR ROTATION, SYSTEM CHECK**

- A. Before testing the system, turn off the pump control, disconnect power, and turn the "Unload Time" (pot 1), on the microprocessor board at each station to a minimum (counter clockwise). The unload timer on each loader provides extended down time at the conclusion of each loading operation, if ever necessary. Normal operation does not require this unload time increase, and the timer should be set to minimum. Unload time will then be determined by the position of the dump valve: Closed when demanding material; Open when the high material level in the receiving hopper keeps it from closing. This open position of the valve opens the demand switch when the discharge valve is pivoted and prevents further loading cycles. Once the material level in the receiving hopper drops, the discharge valve will swing shut, restoring circuit continuity, and placing the loader in the material "Demand" condition. For air powered discharge loaders, the unload timer must be set to allow loader to completely discharge.
- B. The vacuum pump is shipped with oil, but should be checked prior to running. Also, check to see if vacuum hopper, pump, and dust collector protection filters are in place. With 3-phase pump power off and at least one loader control turned on and demanding material, turn on the power switch at the Selectronic Power Supply. The starter within the pump control should pull in. Allow it to drop back out, turn the power supply "Off", then disconnect the vacuum line at the pump and close the 3-phase switch for the pump to check the rotation. Turn the power supply "On". If air flow is observed to be out of the vacuum connection, direction is backwards. Change any two legs of 3-phase. Air flow should be negative at the pump inlet. Reconnect vacuum line. Unit is ready to run.

OPERATION

NOTE: The Selectronic 4+ control contains selectable **no material fault alarms**. These alarm features are selected by turning on or off switches located on the microprocessor PC board, identified as switches #1 through 4. See Page 15 for description.

- C. First, test all single tube loaders in the system without using material. Turn on the power supply. Turn on the first single tube loader and be sure it is "Demanding" material. (No material in receiving hopper) Set the timer to maximum. The popper valve should open and the pump should start running. All other vacuum valves in the system should be closed. After two minutes, the valve should close on this loader, and the loading cycle should stop. Testing the loader with no material, as described, means that the "Unload", or "Off-time" of the loader will be minimal, since the discharge valve of the loader will not prevent the loader from running. After a few seconds, therefore, the loader should restart. Now set the load control to minimum. Repeat this check at all single tube loaders, observing that each loader cycles according to load time.
- D. Next check the ratio loader stations. This procedure is the same as the single tube units, except that the Selectronic Ratio Control cycles the mixing valve. With the "Load" control set to maximum, set the "Regrind" control to 50%. You should observe that the ratio valve cycles between virgin and regrind and provides approximately equal opening of each material line. At the conclusion of the load cycle, the virgin line should close and the regrind open. Unload time should once again be minimal, when no material is used for the test.

NOTE: **Regrind will load first, then virgin.**

- E. Next check the Gemini units in the same manner. Operation should be identical to the units described above, except that a vibrator accompanies the unload cycle.

OPERATION

- F. Next, check those stations using the unit control adapter and an Autocolor. These units are also checked to be sure the pump turns on when the unit calls for material and the vacuum valve on the unit functions. Refer to the individual instructions of the units for proper functioning.
- G. Once proper operation is confirmed, turn off all units, and proceed with checking each station individually with material. Starting with Station #1, set load time to mid-position. With the material line of the loader connected to a material source (feed tube, distribution box, etc.), observe the flow of material into the loader. Successful, trouble-free vacuum loading is accomplished by drawing an optimum proportion of air and material through the tubing, into the loader. This mixture should provide maximum material movement, but not so much as to cause an immovable block in the material line when vacuum is shut off. Use the distribution box air adjustment tubes, or feed tube holes to provide optimum material flow.

The loader should now be cycled several times, with material, while the load time is adjusted to conform closest to the required filling time of each hopper, plus two to five seconds (**Do not overfill loaders or pack in material. This could cause discharge and filter problems, as well as, lower conveying rates**).

- H. When testing ratio units, a balance between virgin and regrind is desired, as determined by your molding requirements. The regrind control permits this ratio to be set on the control face, but once material flow characteristics are established, you may wish to increase or decrease the number of cycles occurring with each loading cycle to minimize load time or maximize material mixing. To do this, disconnect the loader from the system by unhooking the connector cable and turn pot 2 on the microprocessor board. This setting establishes the number of movements the ratio valve will make within the given load time.

OPERATION

- I. Testing Powder Loaders follows the same procedure, but a load sensor in the vacuum hopper stops loading when it becomes covered with material. To check operation, turn the load time to maximum, and begin to load material. With optimum material flow, the vacuum hopper should fill to the load sensor within a reasonable time determined by material flow characteristics and distance. If it does not, too little sensitivity may be indicated, and the sensor is not detecting the presence of the powder. Adjust the sensitivity screw on the back of the sensor until it detects the density of the powder, but does not prohibit loading due to residual dust tripping the sensor.

NOTE: Indication of too little sensitivity is a large amount of dust carry-over in the vacuum line and system dust collector. See the individual powder loader instructions for more details.

Note that in the proper operation, the load timer pot acts as a load time override adjustment, which, if a problem develops with the material source (no material, feed tube blockage, etc.), will by-pass load sensor tripping and terminate the loading sequence.

- J. Once all loaders are calibrated and running, be sure to double check that each unit shuts down when the receiving hopper is full. This condition is indicated by the bin full light turning on. In this condition, the rise of the material in the receiving hopper blocks the free swing of the discharge valve back to a closed (Demand) position.

OPERATION**LOAD AND HOLD SWITCH****NO MATERIAL FAULT ALARM SWITCHES**

Normally Closed or Normally Open Demand
Printed Circuit Board Switch Settings

Switch 1	On	Load and hold selected, at end of load cycle load will not be discharged from loader until bin level input demands material (Requires optional air operated discharge and bin level sensor)
	Off	Load and hold not selected
Switch 2	On	Bin level sensor alarm activated if bin level sensor not satisfied after 255 load cycles on power up or 2 successive load cycles after bin level sensor is satisfied. Material flow fault indicator will light (Requires optional bin level sensor)
	Off	Bin level sensor alarm not activated
Switch 3	On	Load fault alarm activated if 3 successive loads fail to open discharge valve, material flow fault will light
	Off	Load fault alarm not activated
Switch 4	On	Fill to sensor alarm activated. If fill sensor not satisfied at the end of a load cycle, material flow fault will light. (Requires optional fill sensor).
	Off	Fill to sensor alarm not activated.

SECTION**3****OPERATION**

Switch 5	On	Normal operation with discharge valve N.C.
	Off	For operation with non-standard N.O. level switches.

**SUMMARY OF LED FUNCTIONS ON LOADER
MICROPROCESSOR BOARDS**

LED 1	Load	Indicates load output of control board. Turns on vacuum motor on Self-Contained Loader.
LED 2	Air Discharge	This signal turns on a relay that operates the air discharge solenoid. For powder loaders this output controls the vibrator.
LED 3	Ratio	This signal turns on the ratio output relay.
LED 4	Purge	This signal turns on a relay that operates the purge solenoid.
LED 5	Alarm	This signal turns on a relay that provides 110 VAC up to 1 Amp to power an external alarm.
LED 6	BBL (Blowback)	This signal turns on a relay that operates the blowback solenoid for Self-Contained Material Loader.
LED 7	Not Used	
LED 8	LSI (Level Switch 1)	Indicates the loader needs material. Starts the load cycle.

OPERATION

- LED 9 Bin Level When load and hold function selected, this indicates material should be held in loader at end of load cycle.
- LED 10 LS2
(Level Switch 2) Optional. This input from the high level sensor, terminates the load cycle.
- LED 11 DI
(Demand In) Part of selectronic operation. Indicates when any loader in the string is loading. If a particular loader is calling for material, but DI LED and pump do not come on, check fuse FU8. Also used to reset the load cycle after the last loader is finished loading.
- LED 12 DO
(Demand Out) Part of selectronic operation. This signal turns the pump on. Should be on whenever this loader calls for material.
- LED 13 LL
(Last Loader) Part of selectronic operation. Enables this loader to load. Loader will not load until this light goes out.
- LED 14 NL
(Next Loader) Part of selectronic operation. LED goes out when load signal is passed on to the next loader.
- LED 15 +5 Indicator for the +5 VDC power supply for the logic section. Should be on all the time, if not, replace fuse FU7.
- LED 16 +12 Indicator for the +12 VDC power supply for selectronic operation. Should be on all the time, if not replace fuse FU9.

SECTION**3****OPERATION****SUMMARY OF FUSE FUNCTIONS ON
LOADER MICROPROCESSOR BOARDS**

FU1	1 Amp	Load Output
FU2	1 Amp	Air Discharge Output
FU3	1 Amp	Ratio Output
FU4	1 Amp	Purge Output
FU5	1 Amp	Alarm Output
FU6	1 Amp	Blowback Output
FU7	3 Amp	Circuit Board Power Supply
FU8	.5 Amp	Selectronic Communications
FU9	1 Amp	Selectronic Power Supply
FU10	3 Amp	AC Power Supplied to Circuit Board

TROUBLESHOOTING

TROUBLESHOOTING

Before troubleshooting, refer to the installation and operation sections of this manual to insure that set-up is correct.

SYMPTOM	PROBABLE CAUSE	SOLUTION
Loader will not cycle	No 110 VAC power to control	Apply Power
	Circuit Breaker switch on, loader is off. (Light should be on)	Turn breaker switch on.
	Short circuit has tripped breaker switch	Find and repair the short circuit
	Level switch not calling for material; LED 8 (Demand) light off. 1. Material tripping level switch 2. Switch Malfunction	1. Normal condition 2. Repair or replace switch
	Pump fuse FU8 blown	Investigate/replace
	Load sensor tripped, LED 10 on)	1. Insure sensor is clear of material or other obstructions. 2. Adjust or replace sensor as necessary.
	Incorrect switch settings on control board (refer to summary of switch settings)	Change settings as necessary
	Selectronic plant wiring defective (refer to summary of LED functions)	Correct wiring problems

(Continued on Next Page)

SECTION

4

TROUBLESHOOTING

SYMPTOM	PROBABLE CAUSE	SOLUTION
Loader will not cycle (Cont.)	Check Fuse FU1. Control board defective (Refer to summary LED functions)	Replace fuse FU1. Replace control board
	Solenoid malfunction on loader or dust collector	Repair wiring or replace solenoid as necessary.
	Compressed Air Supply not connected	Connect Compressed Air Supply
Ratio valve malfunction	Ratio valve solenoid malfunction	Check fuse FU3, repair wiring or replace solenoid, as necessary
	Air cylinder binding	Install lubricator on air line
	Output relay in controller defective. Refer to LED functions.	Replace control board
	Ratio (regrind) potentiometer defective or improperly connected	Repair wiring, or replace potentiometer as necessary
Load time adjustment malfunction	Load potentiometer defective or improperly connected	Repair wiring or replace potentiometer as necessary
	Load sensor tripped	Check switch for obstruction or malfunction
	Control board defective	Replace control board
Large Amount of dust carry-over in dust collector (Gemini Loader)	Inoperative or mis-adjusted hopper sensor - does not properly terminate load sequence	Recalibrate sensor to detect rise of powder in vacuum hopper or replace

(Continued on Next Page)

TROUBLESHOOTING

SYMPTOM	PROBABLE CAUSE	SOLUTION
Loader Cycles properly, low or no material flow	Dirty filter on loader, dust collector, or pump (indicated by high reading on gage at vacuum pump)	Clean filter(s)
	Incorrect setting at distribution box or pickup tube	Adjust air-to-material setting on pickup tube or distribution box for best flow
	Leaks in vacuum or material line (indicated by low reading on gage at vacuum pump)	Repair leaks or replace hose as necessary
	Pump inoperative	Check/re-set overloads on pump motor starter Replace vacuum pump. Replace vacuum pump motor.
	No or low compressed air supply to loader or Dust Collector.	Check air supply and pressure.

Conair has made the largest investment in customer support in the plastics industry. Our service experts are available to help with any problem you might have installing and operating your equipment. Your Conair sales representative also can help analyze the nature of your problem, assuring that it did not result from misapplication or improper use.

WE'RE HERE TO HELP

To contact Customer Service personnel, call:



HOW TO CONTACT CUSTOMER SERVICE

From outside the United States, call: 814-437-6861

You can commission Conair service personnel to provide on-site service by contacting the Customer Service Department. Standard rates include an on-site hourly rate, with a one-day minimum plus expenses.

If you do have a problem, please complete the following checklist before calling Conair:

- Make sure you have all model, serial and parts list numbers for your particular equipment. Service personnel will need this information to assist you.
- Make sure power is supplied to the equipment.
- Make sure that all connectors and wires within and between loading control and related components have been installed correctly.
- Check the troubleshooting guide of this manual for a solution.
- Thoroughly examine the instruction manual(s) for associated equipment, especially controls. Each manual may have its own troubleshooting guide to help you.
- Check that the equipment has been operated as described in this manual.
- Check accompanying schematic drawings for information on special considerations.

BEFORE YOU CALL ...

Additional manuals and prints for your Conair equipment may be ordered through the Customer Service or Parts Departments for a nominal fee.

EQUIPMENT GUARANTEE

Conair guarantees the machinery and equipment on this order, for a period as defined in the quotation from date of shipment, against defects in material and workmanship under the normal use and service for which it was recommended (except for parts that are typically replaced after normal usage, such as filters, liner plates, etc.). Conair's guarantee is limited to replacing, at our option, the part or parts determined by us to be defective after examination. The customer assumes the cost of transportation of the part or parts to and from the factory.

PERFORMANCE WARRANTY

Conair warrants that this equipment will perform at or above the ratings stated in specific quotations covering the equipment or as detailed in engineering specifications, provided the equipment is applied, installed, operated and maintained in the recommended manner as outlined in our quotation or specifications.

Should performance not meet warranted levels, Conair at its discretion will exercise one of the following options:

- Inspect the equipment and perform alterations or adjustments to satisfy performance claims. (Charges for such inspections and corrections will be waived unless failure to meet warranty is due to misapplication, improper installation, poor maintenance practices or improper operation.)
- Replace the original equipment with other Conair equipment that will meet original performance claims at no extra cost to the customer.
- Refund the invoiced cost to the customer. Credit is subject to prior notice by the customer at which time a Return Goods Authorization Number (RGA) will be issued by Conair's Service Department. Returned equipment must be well crated and in proper operating condition, including all parts. Returns must be prepaid.

Purchaser must notify Conair in writing of any claim and provide a customer receipt and other evidence that a claim is being made.

WARRANTY LIMITATIONS

Except for the Equipment Guarantee and Performance Warranty stated above, Conair disclaims all other warranties with respect to the equipment, express or implied, arising by operation of law, course of dealing, usage of trade or otherwise, including but not limited to the implied warranties of merchantability and fitness for a particular purpose.

NO.	QUANTITY	PART NUMBER	DESCRIPTION
1	1	107-477	SOLENOID 44V 15000007
2	1	203-055-05	120V SWITCH 2500VA140161-CD
3	1	107-481-06-02	17-120V LAMP RED W/CS
4	1	206-067-18	DISCRIMINATING PIN BATTERY
5	1	106-197-06-01	SOLENOID 44 LAMP
6	1	107-463-08-02	WIRING HARNESS SELECTRONIC 4+
7	1	107-197-02	SEL. 4 INTERCONNECTING CABLE USE

WIRE	COLOR	FUNCTION	LENGTH	END CONNECTION
1	BLACK	AC HOT	5'-5/8"	50-25
2	WHITE	AC NEUTRAL	5'-5/8"	50-25
3	BROWN	EARTH GROUND	5'-7/8"	50-25
4	BROWN	SOLENOID	5'-7/8"	50-25
5	RED	SOLENOID	5'-7/8"	50-25
6	BLUE	SOLENOID	5'-7/8"	50-25
7	BLACK	SOLENOID	5'-7/8"	50-25
8	GREEN	SOLENOID	5'-7/8"	50-25
9	WHITE	SOLENOID	5'-7/8"	50-25
10	WHITE	SOLENOID	5'-7/8"	50-25

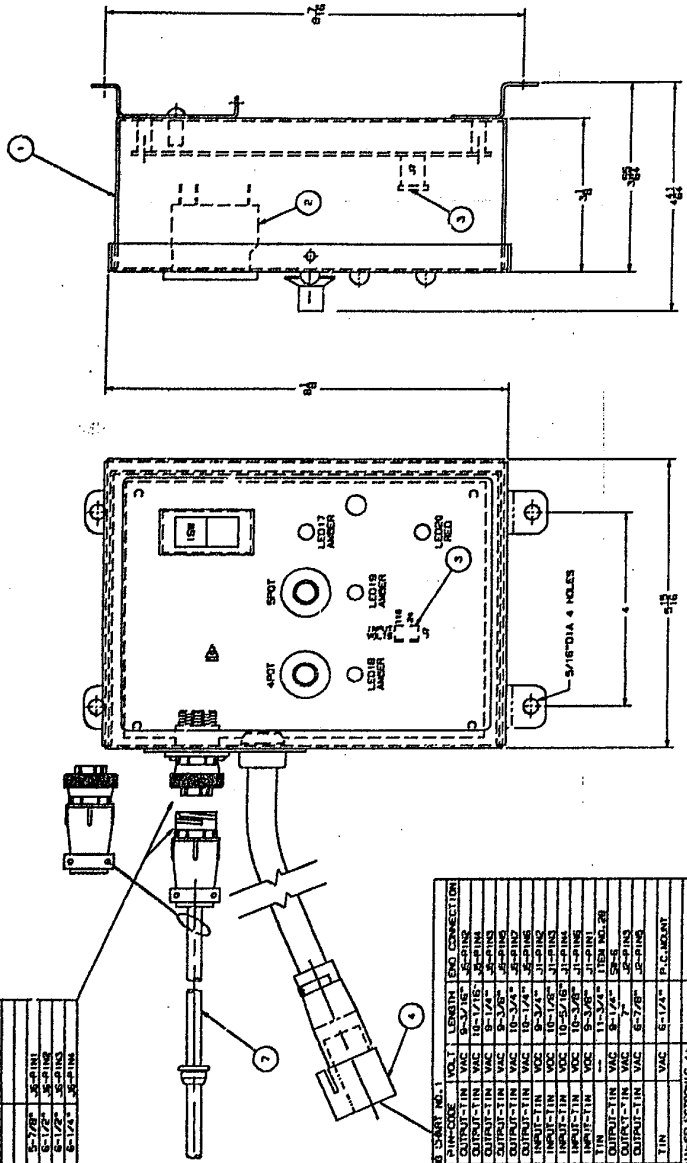

WIRE	COLOR	FUNCTION	PIN-NO.	VOL.	LENGTH	END CONNECTION
1	BROWN	SOLENOID	1	VAC	16-1/2"	50-25
2	RED/YELLOW	AIR DISCHARGE	2	VAC	8-1/2"	50-25
3	RED	SOLENOID	3	VAC	8-1/2"	50-25
4	RED/GREEN	SOLENOID	4	VAC	8-1/2"	50-25
5	WHITE	SOLENOID	5	VAC	8-1/2"	50-25
6	BLACK	SOLENOID	6	VAC	8-1/2"	50-25
7	RED/BLACK	SOLENOID	7	VAC	8-1/2"	50-25
8	GRAY	SOLENOID	8	VAC	8-1/2"	50-25
9	YELLOW	SOLENOID	9	VAC	8-1/2"	50-25
10	WHITE	SOLENOID	10	VAC	8-1/2"	50-25
11	GREEN	SOLENOID	11	VAC	8-1/2"	50-25
12	TAN	SOLENOID	12	VAC	8-1/2"	50-25
13	RED	SOLENOID	13	VAC	8-1/2"	50-25
14	WHITE	SOLENOID	14	VAC	8-1/2"	50-25
15	BROWN	SOLENOID	15	VAC	8-1/2"	50-25
16	GREEN	SOLENOID	16	VAC	8-1/2"	50-25
17	SHIELD	SOLENOID	17	VAC	8-1/2"	50-25
18	SHOCK	SOLENOID	18	VAC	8-1/2"	50-25
19	DISCRIMINATING PIN-SELECTRONIC 4+	SOLENOID	19	VAC	8-1/2"	50-25

CONA IR
FRANKLIN
ELECTRONIC 4+
SELF CONTAINED CONTROL ASSEMBLY
FUNCTIONAL
DATE: 10-1-68
BY: JLF
REV: 10-1-68

FOR WIRING CONNECTIONS SEE 107-477-02

REV.	DATE	BY	CHK.
1	10-1-68	JLF	MS
2	10-1-68	JLF	MS
3	10-1-68	JLF	MS

ORIGINAL

WIRING CHART NO.2

J5	COLOR	FUNCTION	LEAD CONNECTION
PIN 1	BLACK	AC HOT	SW-22
PIN 2	WHITE	NEUTRAL	SW-3
PIN 3	BROWN	EARTH GROUND	SW-3
PIN 4	GREEN	EARTH GROUND	P.C.MOUNT
PIN 5	BROWN	COMMON	J6-PIN1
PIN 6	RED	LAST LOADER	J6-PIN2
PIN 7	BLUE	DEMAND	J6-PIN3
PIN 8	ORANGE	DEMAND	J6-PIN4
PIN 9	BROWN	NEXT LOADER	J6-PIN5

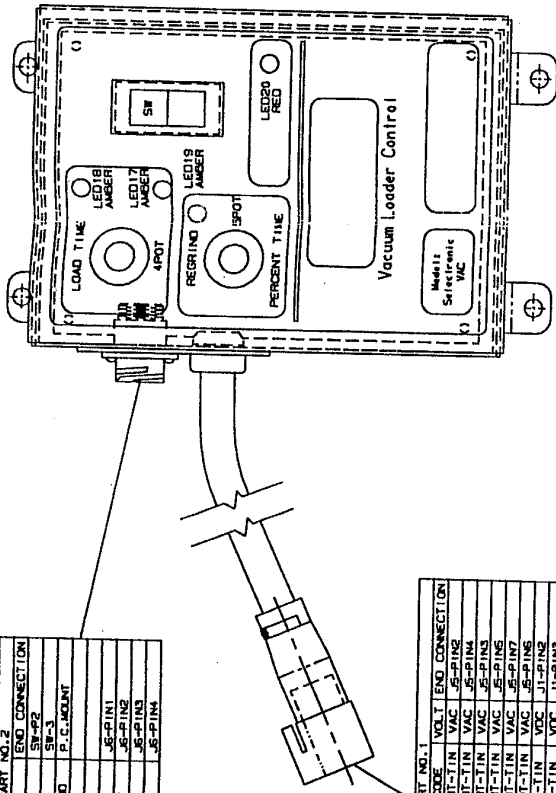

WIRING CHART NO.1

J5	COLOR	FUNCTION	PIN-CODE	VOLT	LEAD CONNECTION
PIN 1	BLACK	LOAD ACT.	OUTPUT-TIN	VAC	J5-PIN2
PIN 2	BROWN	RATIO ACT.	OUTPUT-TIN	VAC	J5-PIN3
PIN 3	RED	AIR DISCHARGE	OUTPUT-TIN	VAC	J5-PIN4
PIN 4	RED/GREEN	ALARM	OUTPUT-TIN	VAC	J5-PIN5
PIN 5	BLUE	ALARM	OUTPUT-TIN	VAC	J5-PIN7
PIN 6	VIOLET	ALARM	OUTPUT-TIN	VAC	J5-PIN8
PIN 7	RED/BLACK	FILL LEVEL	INPUT-TIN	VAC	J1-PIN2
PIN 8	GRAY	BIN LEVEL	INPUT-TIN	VAC	J1-PIN3
PIN 9	YELLOW	VALVE POSITION	INPUT-TIN	VAC	J1-PIN4
PIN 10	PINK	SENSOR COMMON	INPUT-TIN	VAC	J1-PIN5
PIN 11	ORANGE	SENSOR POWER	INPUT-TIN	VAC	J1-PIN6
PIN 12	RED	SPARE	TIN	--	ITEM NO.28
PIN 13	RED	AC HOT	OUTPUT-TIN	VAC	SW-6
PIN 14	WHITE	NEUTRAL	OUTPUT-TIN	VAC	SW-6
PIN 15	GREEN	EARTH GROUND	OUTPUT-TIN	VAC	SW-6
PIN 16	RED	SHIELD	TIN	--	VAC
PIN 17	RED	DISCRIMINATING	PIN-SELECTRONIC 5	VAC	P.C.MOUNT
PIN 18	24VAC				
PIN 19	120VAC				

- LED-01 = VACUUM ON
- LED-02 = AIR DISCHARGE
- LED-03 = RATIO
- LED-04 = PURGE
- LED-05 = ALARM
- LED-06 = BLOW BACK
- LED-07 = POWER-ON BOARD
- LED-08 = BIN LEVEL
- LED-09 = FILL LEVEL
- LED-10 = DEMAND-IN SELECTRONIC
- LED-11 = DEMAND-OUT SELECTRONIC
- LED-12 = NEXT LOADER
- LED-13 = POWER-OFF BOARD
- LED-14 = L10/ BIN FULL
- LED-15 = L10/ LOAD TIME
- LED-16 = L10/ REGRIND/RATIO
- LED-17 = L10/ MATERIAL FAULT
- LED-18 = L10/ REGRIND/RATIO
- LED-19 = L10/ MATERIAL FAULT
- LED-20 = L10/ MATERIAL FAULT

- J1 CONNECTIONS, INPUTS**
- PIN 1 = SENSOR POWER (**12)
 - PIN 2 = BIN LEVEL
 - PIN 3 = FILL LEVEL
 - PIN 4 = VALVE POSITION
 - PIN 5 = SPARE
 - PIN 6 = SENSOR COMMON (D18/8NO)
- J6 CONNECTIONS, SELECTRONIC**
- PIN 1 = COMMON
 - PIN 2 = LAST LOADER
 - PIN 3 = DEMAND
 - PIN 4 = NEXT LOADER

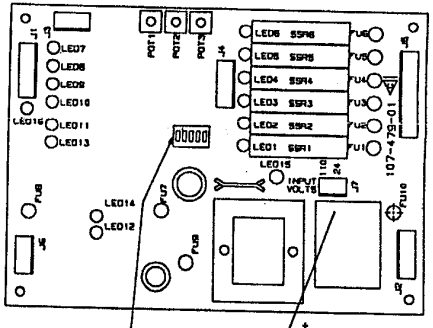

- J2 CONNECTIONS, POWER**
- PIN 1 = A.C. HOT
 - PIN 2 = AC NEUTRAL
 - PIN 3 = AC NEUTRAL
 - PIN 4 = EARTH GROUND
 - PIN 5 = EARTH GROUND
- J3 CONNECTIONS, P.C.B. POWER**
- PIN 1 = 115VAC-SELECTRONIC **
 - PIN 2 = COMMON
 - PIN 3 = 24VAC-SELECTRONIC 5
- J4 CONNECTIONS, LEADS/L10**
- PIN 1 = 4POT A-HIGH
 - PIN 2 = 4POT B-HIGH
 - PIN 3 = 4POT C-LOW
 - PIN 4 = 5POT A-HIGH
 - PIN 5 = 5POT B-HIGH
 - PIN 6 = 5POT C-LOW
 - POT 1 = UNLOAD TIME
 - POT 2 = RATIO CYCLE
 - POT 3 = PURGE TIME
- J5 CONNECTIONS, OUTPUTS**
- PIN 1 = A.C. HOT
 - PIN 2 = VACUUM ON
 - PIN 3 = AIR DISCHARGE
 - PIN 4 = RATIO
 - PIN 5 = PURGE
 - PIN 6 = ALARM
 - PIN 7 = BLOW BACK
 - PIN 8 = NEUTRAL
- J6 CONNECTIONS, LEADS/L10**
- PIN 1 = 17 LED RED LEAD
 - PIN 2 = 17 LED WHITE LEAD
 - PIN 3 = 18 LED RED LEAD
 - PIN 4 = 18 LED WHITE LEAD
 - PIN 5 = 19 LED RED LEAD
 - PIN 6 = 19 LED WHITE LEAD
 - PIN 7 = 20 LED RED LEAD
 - PIN 8 = 20 LED WHITE LEAD

CONA I R FRANKLIN

FRANKLIN POWER VOLTAGE 1523

WIRING CONNECTIONS

TOLERANCE UNLESS OTHERWISE SPECIFIED

FRACTIONAL	DECIMAL	ANGULAR
1/8"	.125	1/2°
1/16"	.0625	1/4°
DATE	08-13-83	DATE

SEE 107-45A-02-03 TO CONNECT TO UNIVERSAL TERMINAL BOX
107-357-01 TO CONNECT TO EXISTING SELECTRONIC 4

NO	DATE	REVISIONS	BY	CHK.	APP.
1	107-27-83				
2	12-27-83				

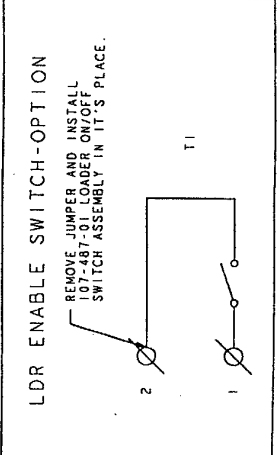
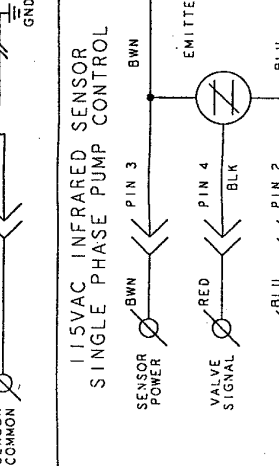
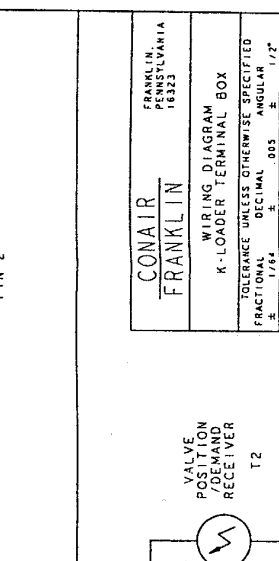
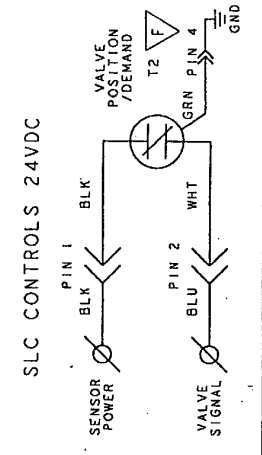
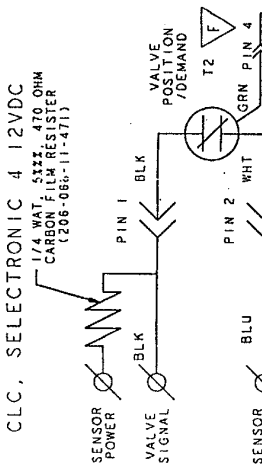
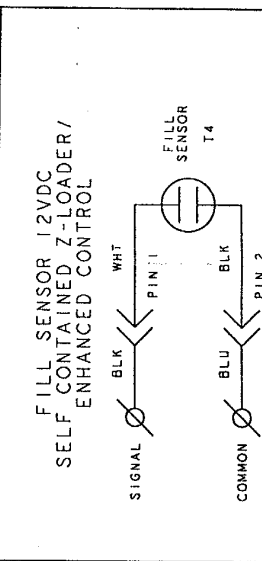
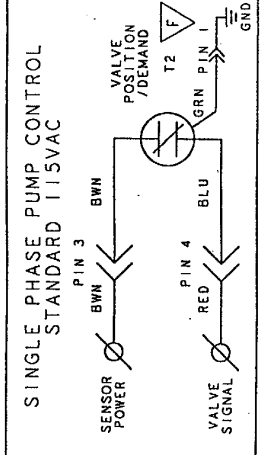
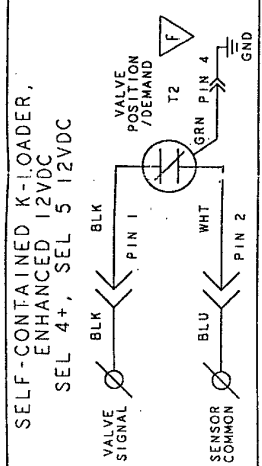
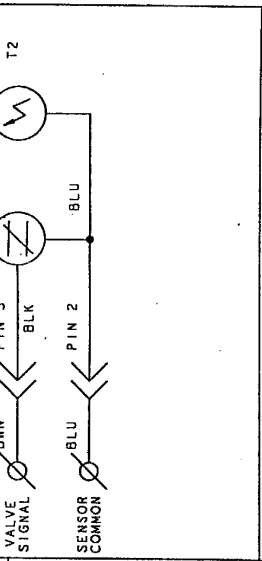
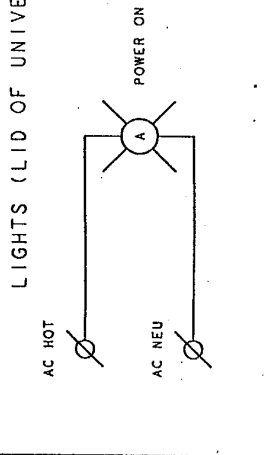
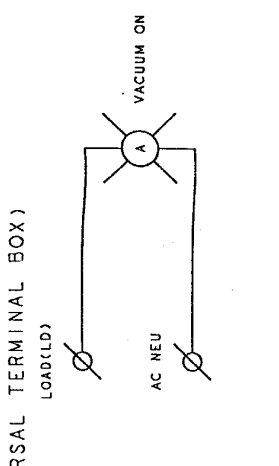
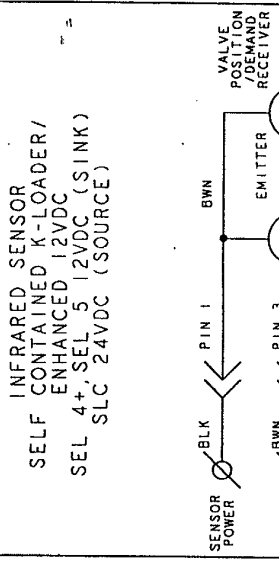

CONAIR		FRANKLIN	
FRANKLIN		PENNSYLVANIA	
16323		WIRING DIAGRAM	
K-LOADER TERMINAL BOX		TOLERANCE UNLESS OTHERWISE SPECIFIED	
FRACTIONAL	DECIMAL	ANGULAR	
INCH	INCH	DEGREE	MINUTE
DATE 9-28-93	DATE	APP 2	DATE
SHT. 1 OF 1 SHTS		107-473-01-01 F	

NO	DATE	REVISIONS	BY	CRD.	APP.
1	9-24-96	ADDED GROUND CONNECTION	HAJ		
2	11-23-96	RED WAS BWN, BWN WAS RED	HAJ		

ITEM NUMBER	DESCRIPTION	PART NUMBER
1	ADAPTER PLATE CABLE MOUNT	105-157-05
2	CONNECTOR AMP 20B7 SERIES	SEE CHART
3	CONTACT PIN-GOLD AMP#60B9-1	208-045-06
4	RD.HD. SCREW NO.4-DUNC 1/4"LG	210-148-02
5	RD.HD. SCREW NO.4-DUNC 1/4"LG	205-033-07
6	15 COND - SHIELDED 18 GA CABLE	205-033-07
7	STRAIN RELIEF HETZCO#SR-31-2	205-033-07
8	SOLD RING TERM. 18B14RB-6	205-030-46
9	19PIN PLUG BUNNDY#BGG1P-1	208-067-03
10	STRAIN RELIEF COUPLING	207-023-07
11	PIGTAIL STRAIN RELIEF	208-067-17
12	7/8 SOCKET BURNDY#SC16M-1TK6	235-007-18-10
13	WIRE NO.18 BLACK 9-5/8" 12-1/2"	205-007-18-08
14	WIRE NO.18 WHITE 11-1/8" 12-1/2"	205-007-18-08
15	90 DEG SOLD TERM HOLL.#205380SF	209-080-32
16	SOLD TERM HOLLINGSWORTH#205383SF	205-007-18-05
17	WIRE NO.18 GREEN 8-1/2"LG	205-007-18-02
18	WIRE NO.18 RED 8-1/2"LG	205-007-18-02
19	WIRE NO.18 BLUE 8-1/2"LG	205-007-18-06
20	WIRE NO.18 ORANGE 8-1/2"LG	205-007-18-03
21	WIRE NO.18 BROWN 8-1/2"LG	205-007-18-01
22	4 PIN CONNECTOR AMP#E40A31	208-069-11
23	COVER AMP#E40551-4	208-069-12
24	5 PIN CONNECTOR AMP#E40A31-5	208-069-14
25	COVER AMP#E40551-5	208-069-15
26	6 PIN CONNECTOR AMP#E40A31-6	208-069-17
27	COVER AMP#E40551-6	208-069-18
28	8 PIN CONNECTOR RIACON#R3100310B	209-015-01
29	WIRE NUT IDEAL NO.718	209-055-01
30	4" WIRE TIES	208-067-18
31	DISCRIMINATING PIN-SEE CHART	208-045-34
32	PANEL MOUNT FLANGE-PLUG	209-080-32
33	SOLD RING TERM. AMP#E40A32	209-080-32

J9	COLOR	FUNCTION	LENGTH	END CONNECTION
PIN 1	BLACK	AC HOT	10"	SW-P2
PIN 2	BROWN	AC HOT	10"	SW-P2
PIN 3	RED/YELLOW	AIR DISCHARGE	9"	SW-P2
PIN 4	RED/GREEN	PURGE	9"	ITEM NO.32
PIN 5	YELLOW	SLOW BACK ACT.	8-1/2"	J6-P1M1
PIN 6	GRAY	FILL SENSOR	8-1/2"	J6-P1M1
PIN 7	RED/BLACK	BIR LEVEL	8-1/2"	J6-P1M1
PIN 8	YELLOW	VALVE POSITION	8-1/2"	J6-P1M1
PIN 9	PINK	SENSOR COMMON	8-1/2"	J6-P1M1
PIN 10	PINK	SENSOR POWER	8-1/2"	J6-P1M1
PIN 11	ORANGE	AC NEUTRAL	8-1/2"	J6-P1M1
PIN 12	GREEN	GROUND	8-1/2"	J6-P1M1
PIN 13	RED	AC HOT	8-1/2"	J6-P1M1
PIN 14	WHITE	AC NEUTRAL	8-1/2"	J6-P1M1
PIN 15	GREEN	GROUND	8-1/2"	J6-P1M1
PIN 16	RED	AC HOT	8-1/2"	J6-P1M1
PIN 17	GREEN	GROUND	8-1/2"	J6-P1M1
PIN 18	RED/VAC	SHIELD	8-1/2"	ITEM NO.7

WIRING CHART NO. 1	WIRING CHART NO. 2
19	1
PIN 1	BLACK
PIN 2	BROWN
PIN 3	RED/YELLOW
PIN 4	RED/GREEN
PIN 5	YELLOW
PIN 6	GRAY
PIN 7	RED/BLACK
PIN 8	YELLOW
PIN 9	PINK
PIN 10	PINK
PIN 11	ORANGE
PIN 12	GREEN
PIN 13	RED
PIN 14	WHITE
PIN 15	GREEN
PIN 16	RED
PIN 17	GREEN
PIN 18	RED/VAC

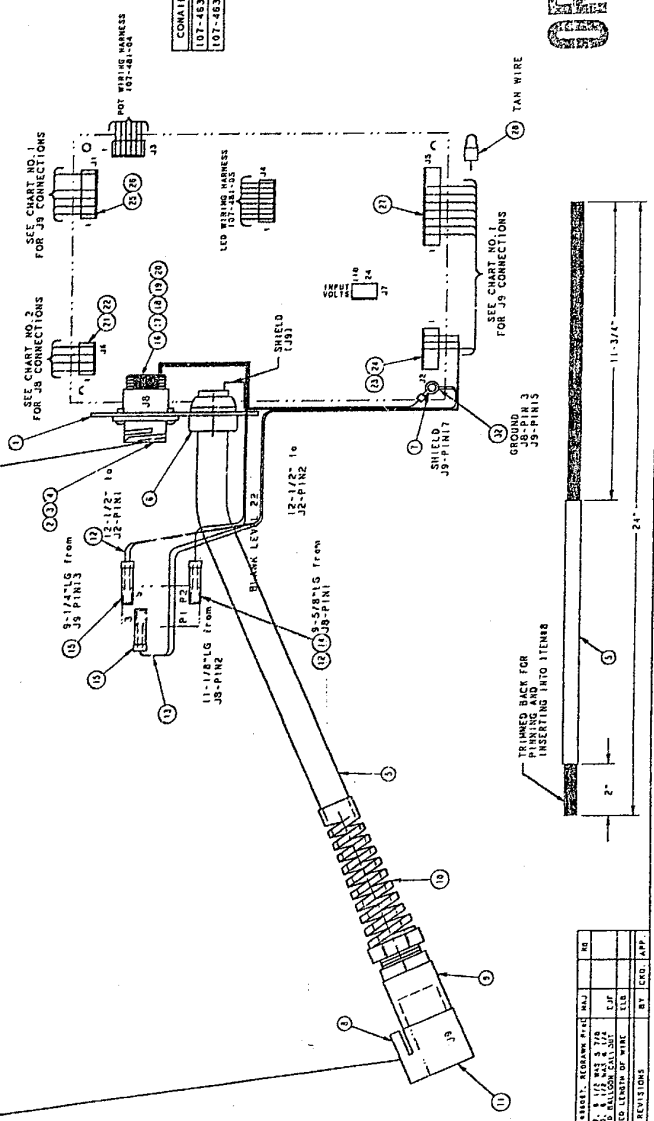

CONAIR NO.	CONTROL	ITEM 2	ITEM 30	ITEM #100
107-463-09-01	SEL-5	208-045-08	J9-P1M18	-0-
107-463-09-02	SEL-4	208-045-02	J9-P1M19	DTY-1
				107-463-09

CONAIR FRANKLIN	
FRANKLIN, OHIO 45422	
WIRING HARNESS SEL 4+5	
DATE	107-463-09-01
REV.	107-463-09-02
DATE	107-463-09-03
REV.	107-463-09-04
DATE	107-463-09-05
REV.	107-463-09-06
DATE	107-463-09-07
REV.	107-463-09-08
DATE	107-463-09-09
REV.	107-463-09-10

ORIGINAL

NO	DATE	REVISIONS	BY	CHK. APP.
1				
2				
3				
4				
5				
6				
7				
8				
9				
10				

SEE 107-482-01 FOR 120VAC LIGHT KIT
 107-482-02 FOR 240VAC LIGHT KIT

ITEM NUMBER NO. REQUIRED	PART NUMBER	DESCRIPTION
1	102-950	TERMINAL BOX WELDMENT
2	107-455-01	PC BOARD TERMINAL BOX
3	210-009-02	RD.HD.SCREW NO.6-32NC x 3/4"LG
4	107-463-01	CABLE ASSEMBLY-TERMINAL BOX
5	210-148-02	RD.HD.SCREW NO.4-40NC x 1/4"LG
6	102-963	FRONT COVER WELDMENT
7	299-216-145	LABEL KIT - TERMINAL BOX
8	208-067-15	TIN PLATED PIN
9	200-054-01	RELAY (MOTOR)
10	REF	RD.HD.SCREW NO.6-32NC x 3/8"LG
11	299-216-143	LABEL -- FRONT COVER
12	208-045-18	FLANGED RECEPT.-"AMP#206430-1
13	208-045-05	SOCKET PIN AMP 66101-2 TIN
14	208-045-07	SOCKET PIN AMP 66101-1 GOLD

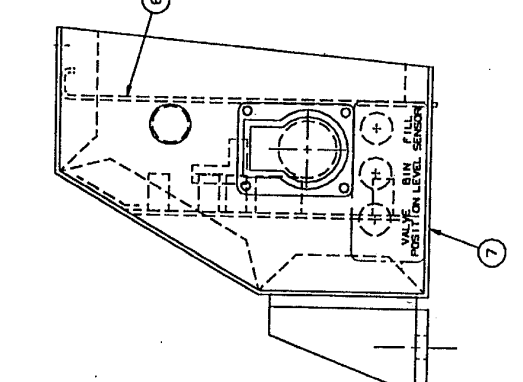
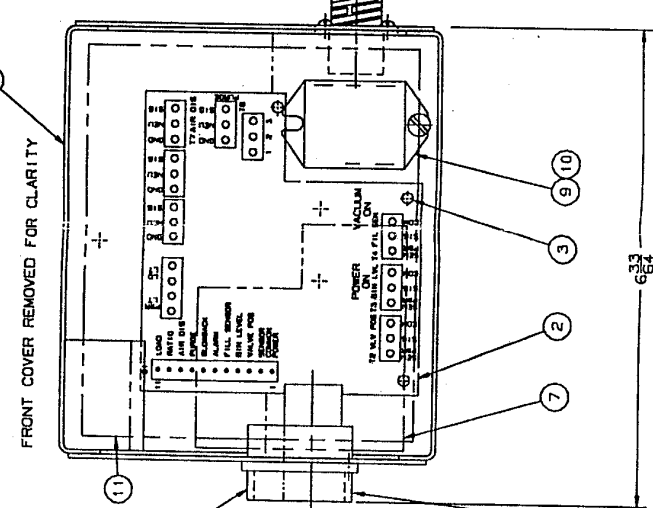
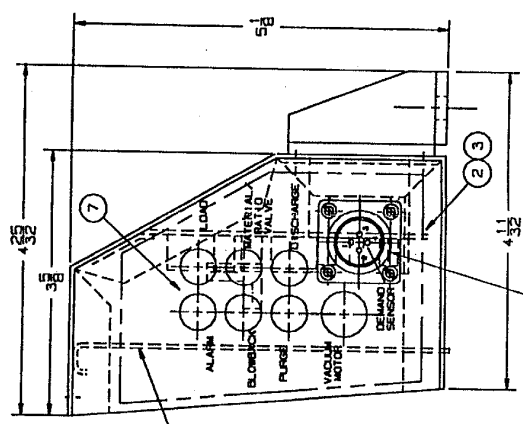

REF. DRAWING 107-454-01
 CONAIR
 FRANKLIN
 FRANKLIN, PENNSYLVANIA 16323
 UNIVERSAL TERMINAL BOX
 K-LOADER & Z-LOADER
 TOLERANCE UNLESS OTHERWISE SPECIFIED
 FRACTIONAL DECIMAL .005
 INCHES .125
 ANGULAR 1/2°
 DIM. MAJ. DIM. MIN. DATE APP. DATE
 107-521-01 C

PIN#1 BLK (ITEM# 13)
 PIN#2 BLU (ITEM# 13)
 PIN#3 BWN (ITEM# 13)
 PIN#4 RED (ITEM# 14)

NOTE FOR PIN (ITEM#8)
 IN 18 120VAC
 IN 19 24VAC

SEE 107-454-02 FOR WIRING DIAGRAM

NO.	DATE	REVISIONS	BY	CHKD.	APP.
C	11-24-96	ADDED 13-14, 15, 16, 17, 18, 19, 20, 21, 22, 23, 24, 25, 26, 27, 28, 29, 30, 31, 32, 33, 34, 35, 36, 37, 38, 39, 40, 41, 42, 43, 44, 45, 46, 47, 48, 49, 50, 51, 52, 53, 54, 55, 56, 57, 58, 59, 60, 61, 62, 63, 64, 65, 66, 67, 68, 69, 70, 71, 72, 73, 74, 75, 76, 77, 78, 79, 80, 81, 82, 83, 84, 85, 86, 87, 88, 89, 90, 91, 92, 93, 94, 95, 96, 97, 98, 99, 100	MAJ		
B	11-20-95	ADDED 11, 12, 13, 14, 15, 16, 17, 18, 19, 20, 21, 22, 23, 24, 25, 26, 27, 28, 29, 30, 31, 32, 33, 34, 35, 36, 37, 38, 39, 40, 41, 42, 43, 44, 45, 46, 47, 48, 49, 50, 51, 52, 53, 54, 55, 56, 57, 58, 59, 60, 61, 62, 63, 64, 65, 66, 67, 68, 69, 70, 71, 72, 73, 74, 75, 76, 77, 78, 79, 80, 81, 82, 83, 84, 85, 86, 87, 88, 89, 90, 91, 92, 93, 94, 95, 96, 97, 98, 99, 100	MAJ		

SYM	ITEM NUMBER (REQUIRED)	PART NUMBER	DESCRIPTION
1SW	1	203-056-01	CIRCUIT BREAKER SWITCH 5 AMP
1SSR	2	200-033-01	SOLID STATE RELAY 10 AMP
1SS	3	203-049-01	2 POS. SEL/SW A/B 800MR-HH2BLA-
2,3LT	4	204-014-04	NEON LIGHT 1/0 NO.10500C1-RED
1W	5	2 FT. 205-037-22-09	1061 WIRE NO.22 CONTROL BLACK
2W	6	2 FT. 205-037-18-04	1061 WIRE NO.18 CONTROL YELLOW
3W	7	1 FT. 205-037-18-05	1061 WIRE NO.18 GROUND GREEN
4W	8	2 FT. 205-037-18-08	1061 WIRE NO.18 NEUTRAL WHITE
5W	9	2 FT. 205-037-22-03	1061 WIRE NO.22 CONTROL ORANGE
6W	10	2 FT. 205-037-18-02	1061 WIRE NO.18 CONTROL RED

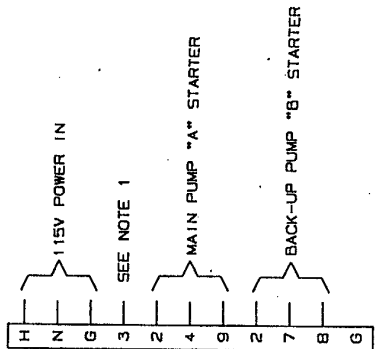
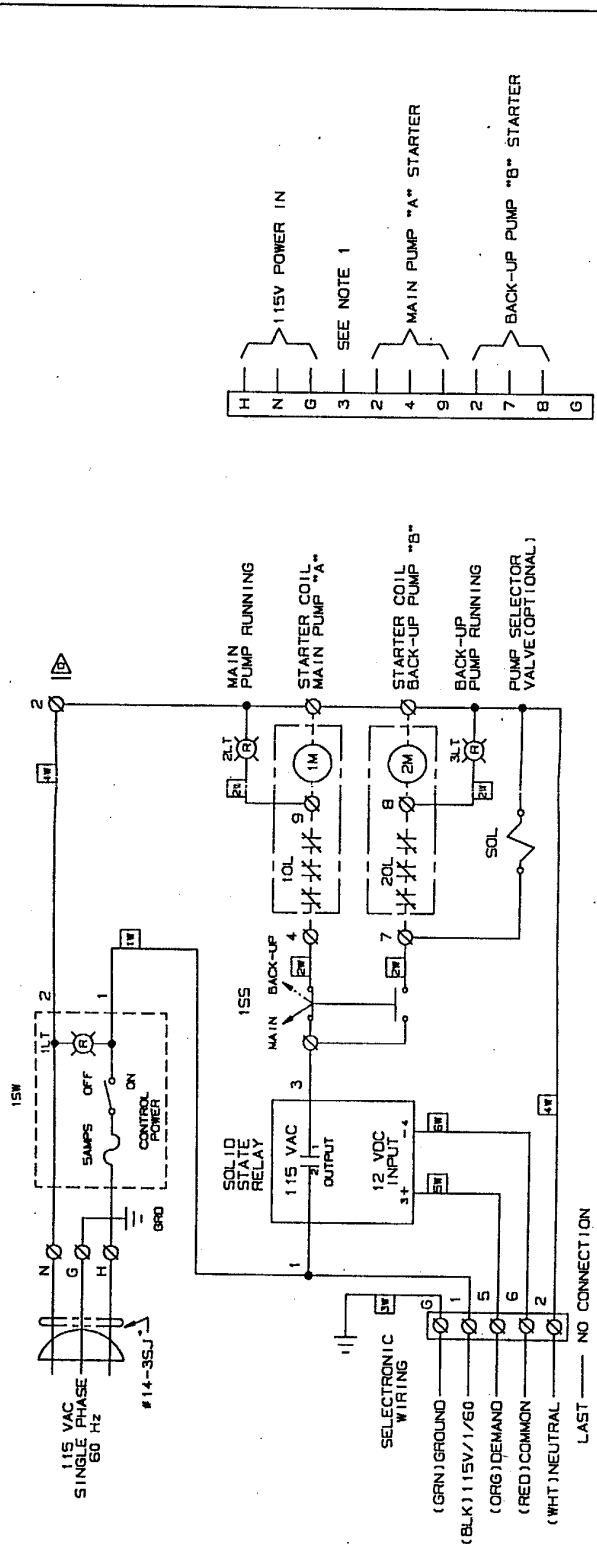

CONAIR FRANKLIN
 FRANKLIN, PENNSYLVANIA 16326

SELECTRONIC POWER SUPPLY WIRING DIAGRAM

TOLERANCE UNLESS OTHERWISE SPECIFIED

FRAC TIONAL	DECIMAL	ANGULAR
1/2	.5	1/2
1/4	.25	1/4
3/16	.1875	3/16
1/8	.125	1/8
3/32	.09375	3/32
1/16	.0625	1/16
3/64	.046875	3/64
1/32	.03125	1/32
1/64	.015625	1/64
1/128	.0078125	1/128
1/256	.00390625	1/256
1/512	.001953125	1/512
1/1024	.0009765625	1/1024
1/2048	.00048828125	1/2048
1/4096	.000244140625	1/4096
1/8192	.0001220703125	1/8192
1/16384	.00006103515625	1/16384
1/32768	.000030517578125	1/32768
1/65536	.0000152587890625	1/65536
1/131072	.00000762939453125	1/131072
1/262144	.000003814697265625	1/262144
1/524288	.0000019073486328125	1/524288
1/1048576	.00000095367431640625	1/1048576
1/2097152	.000000476837158203125	1/2097152
1/4194304	.0000002384185791015625	1/4194304
1/8388608	.00000011920928955078125	1/8388608
1/16777216	.000000059604644775390625	1/16777216
1/33554432	.0000000298023223876953125	1/33554432
1/67108864	.00000001490116119384765625	1/67108864
1/134217728	.000000007450580596923828125	1/134217728
1/268435456	.0000000037252902984619140625	1/268435456
1/536870912	.00000000186264514923095703125	1/536870912
1/1073741824	.000000000931322574615478765625	1/1073741824
1/2147483648	.0000000004656612873077393828125	1/2147483648
1/4294967296	.00000000023283064365386969140625	1/4294967296
1/8589934592	.000000000116415321826934845703125	1/8589934592
1/17179869184	.0000000000582076609134674228515625	1/17179869184
1/34359738368	.000000000029103830456733711193828125	1/34359738368
1/68719476736	.0000000000145519152283668555969140625	1/68719476736
1/137438953472	.00000000000727595761418342779845703125	1/137438953472
1/274877906944	.000000000003637978807091713896928515625	1/274877906944
1/549755813888	.00000000000181898940354585694846428125	1/549755813888
1/1099511627776	.000000000000909494701772928474232140625	1/1099511627776
1/2199023255552	.00000000000045474735088646423711621015625	1/2199023255552
1/4398046511104	.00000000000022737367544323211855810578125	1/4398046511104
1/8796093022208	.000000000000113686837721616059279282890625	1/8796093022208
1/17592186044416	.000000000000056843418860802964646141453125	1/17592186044416
1/35184372088832	.000000000000028421709430401482323070715625	1/35184372088832
1/70368744177664	.000000000000014210854715200741161535378125	1/70368744177664
1/140737488355328	.0000000000000071054273576003705807676890625	1/140737488355328
1/281474976710656	.00000000000000355271367880018529038384453125	1/281474976710656
1/562949953421312	.00000000000000177635683940009264519192228125	1/562949953421312
1/1125899906842624	.000000000000000888178419700046322595961140625	1/1125899906842624
1/2251799813685248	.0000000000000004440892098500231612979805703125	1/2251799813685248
1/4503599627370496	.00000000000000022204460492501158064898928125	1/4503599627370496
1/9007199254740992	.0000000000000001110223024625057903244944140625	1/9007199254740992
1/18014398509481984	.0000000000000000555111512312528951722472228125	1/18014398509481984
1/36028797018963968	.00000000000000002775557561562644761161141140625	1/36028797018963968
1/72057594037927936	.000000000000000013877787807813223805805705703125	1/72057594037927936
1/144115188075855872	.0000000000000000069388939039066119029028528515625	1/144115188075855872
1/288230376151711744	.000000000000000003469446951953305951451426428125	1/288230376151711744
1/576460752303423488	.0000000000000000017347234759766529757257131140625	1/576460752303423488
1/1152921504606846976	.000000000000000000867361737988326488886355705703125	1/1152921504606846976
1/2305843009213693952	.0000000000000000004336808689941632444431778528125	1/2305843009213693952
1/4611686018427387904	.000000000000000000216840434497081622221889264140625	1/4611686018427387904
1/9223372036854775808	.00000000000000000010842021724854081111109463205703125	1/9223372036854775808
1/18446744073709551616	.00000000000000000005421010862427040555547316140625	1/18446744073709551616
1/36893488147419103232	.000000000000000000027105054312135202777736580703125	1/36893488147419103232
1/73786976294838206464	.00000000000000000001355252715606760138888888888140625	1/73786976294838206464
1/147573952589676412928	.000000000000000000006776263578033800694444444428125	1/147573952589676412928
1/295147905179352825856	.000000000000000000003388131789016900347222222140625	1/295147905179352825856
1/5902958103587056517056	.00000000000000000000169406589450845017361111105703125	1/5902958103587056517056
1/11805916207174113134112	.000000000000000000000847032947254225086805555703125	1/11805916207174113134112
1/23611832414348226268224	.0000000000000000000004235164736271125434427778515625	1/23611832414348226268224
1/47223664828696452536448	.00000000000000000000021175823681355627172211388928125	1/47223664828696452536448
1/94447329657392905072896	.0000000000000000000001058791184067781361055569140625	1/94447329657392905072896
1/188894659314785810145792	.00000000000000000000005293955920338906777777705703125	1/188894659314785810145792
1/377789318629571620291584	.0000000000000000000000264697796016945338888888140625	1/377789318629571620291584
1/755578637259143240583168	.000000000000000000000013234889800847266944444428125	1/755578637259143240583168
1/1511157274518286481166336	.000000000000000000000006617444900423633472222140625	1/1511157274518286481166336
1/3022314549036572962332704	.000000000000000000000003308722450211816686111105703125	1/3022314549036572962332704
1/6044629098073145924665408	.0000000000000000000000016543612251058333430555703125	1/6044629098073145924665408
1/12089258196146291849330816	.00000000000000000000000082718061255291667167778515625	1/12089258196146291849330816
1/24178516392292583698661632	.00000000000000000000000041359030627645833388888140625	1/24178516392292583698661632
1/48357032784585167397323264	.000000000000000000000000206795153138229169444428125	1/48357032784585167397323264
1/96714065569170334794646528	.0000000000000000000000001033975765691145847222140625	1/96714065569170334794646528
1/19342813113834066958929312	.00000000000000000000000005169878828455729111105703125	1/19342813113834066958929312
1/38685626227668133917858624	.000000000000000000000000025849394142278605555703125	1/38685626227668133917858624
1/77371252455336267835717248	.0000000000000000000000000129246970711139027778515625	1/77371252455336267835717248
1/15474250491067253567143496	.000000000000000000000000006462348535566951388888140625	1/15474250491067253567143496
1/30948500982134507134286992	.00000000000000000000000000323117426777839759444428125	1/30948500982134507134286992
1/61897001964269014268573984	.000000000000000000000000001615587133888987997222140625	1/61897001964269014268573984
1/12379400392853802853715968	.000000000000000000000000000807793566944493998611105703125	1/12379400392853802853715968
1/24758800785707605707431936	.0000000000000000000000000004038967834722469993055703125	1/24758800785707605707431936
1/49517601571415211414863872	.00000000000000000000000000020194839173612349996528515625	1/49517601571415211414863872
1/99035203142830422829727744	.0000000000000000000000000001009741958680617499826428125	1/99035203142830422829727744
1/19807040628566084565945536	.000000000000000000000000000050487097934030874999132140625	1/19807040628566084565945536
1/39614081257132169131891072	.000000000000000000000000000025243548967015437499565703125	1/39614081257132169131891072
1/79228162514264338263782144	.000000000000000000000000000012621774483507718749778515625	1/79228162514264338263782144
1/158456325028528676527564288	.000000000000000000000000000006310887241753889387488928125	1/158456325028528676527564288
1/316912650057057353055128576	.0000000000000000000000000000031554436208769446937444428125	1/316912650057057353055128576
1/633825300114114706110257152	.0000000000000000000000000000015777218104384723468722140625	1/633825300114114706110257152
1/126765060022822941222051424	.00000000000000000000000000000078886090521923617344361140625	1/126765060022822941222051424
1/253530120045645882444102848	.00000000000000000000000000000039443045260961808671722140625	1/253530120045645882444102848
1/507060240091291764888205696	.000000000000000000000000000000197215226304804043368561140625	1/507060240091291764888205696
1/1014120480182583529776411392	.00000000000000000000000000000009860761315240202168428125	1/1014120480182583529776411392
1/2028240960365167059552822784	.00000000000000000000000000000004930380657620101084240625	1/2028240960365167059552822784
1/405648192073033411910564576	.000000000000000000000000000000024651903288100505421203125	1/405648192073033411910564576
1/811296384146066823821129152	.0000000000000000000000000000000123259516440025271060628125	1/811296384146066823821129152
1/162259276829213364644228304	.000000000000000000000000000000006162975	

QTY. REQUIRED	PART NUMBER	DESCRIPTION
1	102-801-02	POWER BOX WELDMENT
2	105-200-04	ELECTRICAL PANEL
3	209-216-05	LABEL KIT - INSIDE BOX
4	105-200-06	LABEL KIT - OUTSIDE BOX
5	209-137-11	TERMINAL
6	104-907-07	TERMINAL STRIP LABEL
7		
8	209-009-08	TERMINAL BLOCK 8 LUG
9	107-355-01	ELECTRICAL PARTS
10	210-020-02	RD.HD.SCREW NO. 8-32X4
11	210-055-02	RD.HD.SCREW NO. 10-32X4
12	209-010-07	SOLE PLATE
13	209-148-22	NEOSPRENE 1/8 X 1/2X STRIP
14	104-907-05	LABEL - SWITCH BOX
15	209-216-35-01	CONAIR LOGO
16	209-216-28-01	CAUTION LABEL
17	209-005-03	POWER CORD 14-3SJ
18	209-065-01	SAFETY SHROUD LOCK OUT
19	209-009-05	STRAIN RELIEF -ETCO
20	207-001-04	CORD GRIP
20	209-216-05	WIRING DIAGRAM

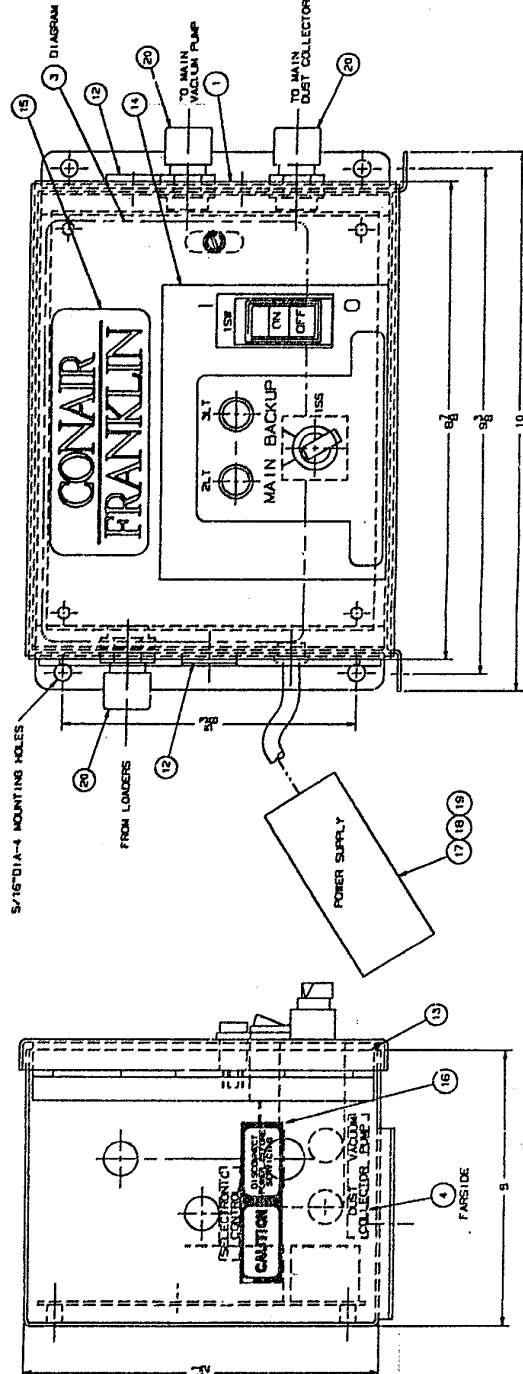
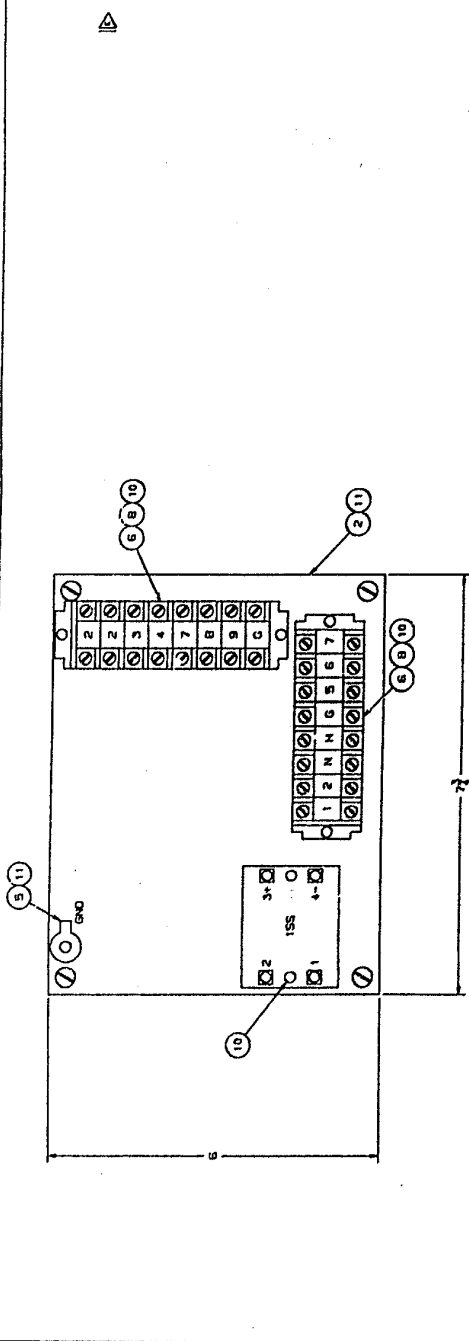

FRANKLIN
CONAIR
 FRANKLIN, MASS.
 POWER BOX ASSEMBLY
 ELECTRICAL PARTS
 FRACTIONAL HORSEPOWER
 1/2 HP
 DATE: 11-1-81
 BY: J. J. SHIRTS
 107-354-01 E

ORIGINAL

REV.	DATE	REVISION	BY	CHK.	APP.
1					
2					
3					
4					
5					
6					
7					
8					
9					
10					
11					
12					
13					
14					
15					
16					
17					
18					
19					
20					