

USERGUIDE

Pendant Board 20E9401x

PENDANT BOARD

Ref. : 20E9401x

Function :

The pendant is made up of a board that manages the keyboard, the display, a printer link and a few ON / OFF inputs / outputs.

The screen is a 320 x 240 pixel graphic display, i.e. 20 lines of 40 characters. It is backlit by a replaceable neon.

Skeleton drawing :

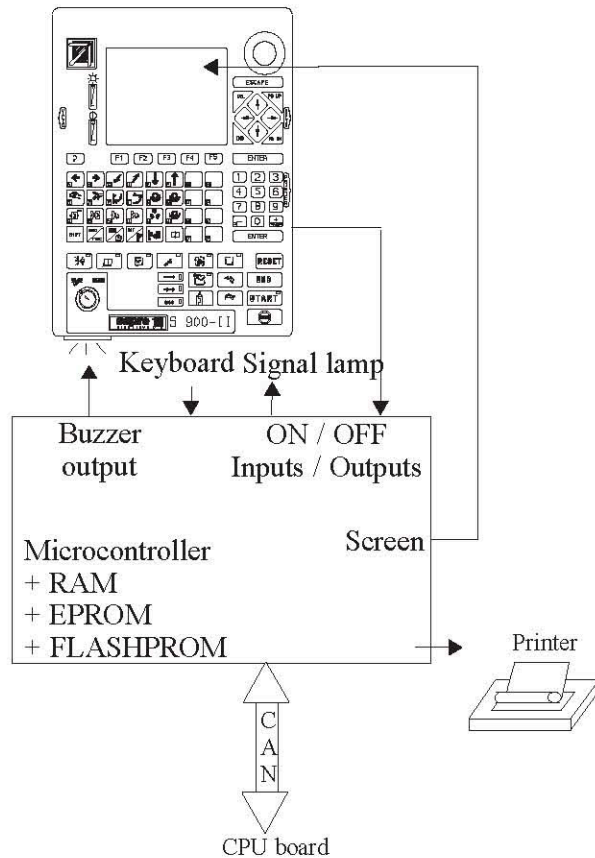

Component lay-out on the board :

Always leave these jumpers in this position

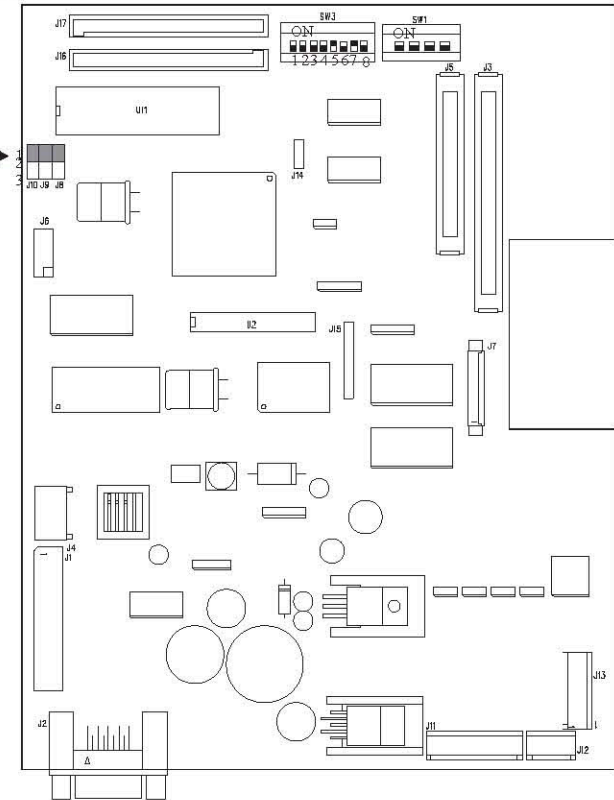

- J1 : Printer ribbon cable
- J2 : Pendant + CAN link power supply
- J3 : Keyboard
- J4 : Neon power supply
- J5 : Keyboard LEDs
- J6, J14, J15, J16 and J17 : Reserved
- J7 : LCD display
- J11 : Button, switch and buzzer inputs
- J12 : I/O + J11 looping power supply
- J13 : 4 additional inputs and 4 additional outputs
- U2 : Programmable component
- U11 : Software

J13 connector : 4 additional inputs and 4 additional outputs connection

Pin	Name	Pin	Name
1	24VIO	2	IN 136
3	24VIO	4	IN 137
5	24VIO	6	IN 138
7	24VIO	8	IN 139
9	OUT 136	10	GNDE
11	OUT 137	12	GNDE
13	OUT 138	14	GNDE
15	OUT 139	16	GNDE

Pendant configuration for a 500Kbit/s CAN link

If the CAN link is longer than 20 metres, you should change the transfer speed from 1Mbits/s to 500Kbits/s.

To change the transmission speed, carry out the following :

- ▶ in the parameters, change the configuration of the “master” node (parameter 45) : add 10 to the value.

 By default the value is 2, so it will become 2 + 10 = 12.

- ▶ Power down the robot cabinet, open the pendant and configure the switches as described below :

The SW3 switches are used to configure the CAN link. The S900-II command parameters MUST be changed if the position of the SW3 switches is changed. The SW3-8 position is not used.

CAN node address (Parameter 46 = 1)					
Switch N°	SW3-1	SW3-2	SW3-3	SW3-4	SW3-5
ON	16	8	4	2	1
OFF	0	0	0	0	0

Bit rate in kb/s (kilobits / second)				Parameter N° 45
SW3-6	SW3-7	Bitrate	Use	CLASS_MSTR_CAN
ON	ON	1000	Very short cable	2
OFF	ON	500	For cabling >20 m	12
ON	OFF	100	–	–
OFF	OFF	20	–	–

- ▶ Power the cabinet up again and the adjustments will be taken into account. (The transfers between the CPU and the PENDANT for the display, keyboard use, ... are now carried out at 500Kbits/s).

Colour and monochrome configurations :

Use the SW1 – 4 switch to set the parameters for the type of display (monochrome or colour). The other SW1 switches are not used.

Colour display	Monochrome display
SW1 – 4 in ON position	SW1 – 4 in OFF position
Colour display 06C02477	Monochrome display 06C02411
Bundle connected on J7 : 20E9440x	Bundle connected on J7 : 20E9530x

Note : The brightness and contrast are memorised after 2 minutes, once they have been adjusted.

-  Never open the pendant when it is powered up. The neon display is powered by a voltage of about 900 V !

Note : The grey areas represent the board’s default configuration.

Replacing the neon tube :

The neon tube reference is the same for a colour or monochrome display : 06C02706.

► Disassembling the neon tube

- Power down the robot's electric cabinet.
- Place the pendant on a clean surface and, if possible, on an anti-static surface. Be careful not to scratch the screen.
- Open the pendant (4 screws on the back).
- Remove the power supply connector from the neon tube (2-pin connector with one pink and one white wire).
- Disconnect the 2 ribbon cables that power the keyboard. To unwire the ribbon cables, remove the 2 side lock latches on the connectors fixed on the pendant board.
- Remove the board from its fixing pins by removing the five 5 mm nuts and the two 5 mm spacers.
- When you are able to access the neon's support screw, remove this screw and free the neon which is supported by a small notch at the opposite end to the screw.

► Putting the neon tube into place

- Position the new neon tube by first inserting the notch, then by fixing the screw.
- Position the board on its fixing nuts and put the 5 nuts and 2 spacers back into place. Push the board in making sure that it is flat but do not push it too hard.
- Put the 2 ribbon cables that power the display back into place. To do this, slip the ribbon cable into the connector fixed on the pendant board. When the ribbon cable is sufficiently advanced and if it is straight, then push in the 2 side lock latches on the connectors fixed on the pendant board.
- Plug the neon tube power supply connector (2-pin connector with one pink and one white wire) into the board.
- Close the pendant (4 screws on the back).
- Power up the robot's electric cabinet to check the functioning of the new neon tube.

The pendant's TEST mode :

There are 2 test pages for the pendant :

- ▶ a test page for the actual pendant

To access this page : switch SW1-1 to ON

- A page of drawings appears in 16 colours or 8 levels of grey, depending on the type of display. This page also shows the state of the internal memory areas (RAM, ROM, Flashprom)
- The keyboard leds flash
- When you press the keys, its code appears on the screen along with an audible beep.

- ▶ a test page for the communication on the CAN network

To access this page : switch SW1-2 to ON

- The display shows the emission buffer, the reception buffer, and, if they exist, the code of the CAN protocol error and the type of hardware error.