

Continuous Blending in Exact, Precise Ratios

TrueWeigh™ Continuous Blenders provide extremely precise loss-in-weight dispensing of dry solids of various size and bulk densities including pellet, regrind, micro-bead and powder. These highly consistent and repeatable blenders are ideally suited to extrusion processes that require perfect blend homogeneity and extremely accurate dosing.

Designed for extrusion rates to 3,000 lb/hr {1,360 kg/hr}, TWB Blenders are available with up to six component positions.



Model TWB07-4

Perfect Multi-Component Homogeneous Blend

TrueWeigh™ Continuous Gravimetric Blenders consist of a series of loss-in-weight material hoppers symmetrically located above a cascade mixing chamber to simultaneously and homogeneously meter all components within a recipe. The system incorporates an extruder throat-mounted weigh hopper which can be supplied as part of the blender or sourced independently. The weigh hopper measures the blended material feed rate and sends that information to the PLC control for monitoring and reporting.

All component hopper-feeder assemblies are mounted on individual single-point contact load cells and are supplied with quick-release, variable speed synchronous motors and configured to accept a range of interchangeable feed augers designed to accommodate specific material shape and flow characteristics. Feeders are inclined for more consistent output and to accommodate fast material drain-out.

▶ Accuracy to +/- 0.5% of set point

The PLC-based control holds each component to +/- 0.5% of its set point. The control uses a proprietary learning algorithm that simultaneously monitors and adjusts each feeder for material flow and bulk density changes.

▶ Homogeneously blend dissimilar materials

Easily and accurately blend virgin pellets, free flowing powders, regrinds, granules, flakes, concentrates and additives. Each component is simultaneously metered through material-specific feed augers. A conical cascade static mixer integrates the materials and eliminates separation caused by ledge or step type cascades.

▶ Add-on extrusion yield control

The blender PLC readily communicates with an extruder through an optional drive card to provide yield control. Add an encoder and haul-off drive control card and you can control line speed and product weight-per-length to +/- 0.5% of target set point.

Configurations



Machine mounted

The machine mounted design includes a TrueWeight™ Gravimetric Hopper mounted direct to the feed throat for monitoring feed rate to the extruder or for optional extrusion yield control.



Stand mounted

The stand mounted design feeds material exiting the static mixer through a central tube design to a remote destination.

Features



Integral loading platform

Canopy cover provides stable mounting platform for hopper material loaders.



100% visibility into material hoppers

Material levels, ingredient type and position are quickly identified and confirmed. Since each material bin is weighed, automatic audible alarms are available for each ingredient.



Easy material and auger changes

Quick change material feed augers are available from 0.5 to 2.0 inch diameters. The material cutoff slide gate allows auger changes to occur with material still present in the hopper. Auger feeder motors are easily removed with quick-release clamps. The inclined auger tube allows a complete and easy way of draining materials.



Static mixer

The conical static mixing chamber provides the most homogenous material blend available. Discriminating processors that require a perfect mix, with no mechanical agitation required, can rely on the Conair cascade static mixer for those critical product applications.



Mass flow loss-in-weight hoppers

Sixty degree cone angle assures consistent mass flow, and prevents material separation within the central weigh hopper.



Single point-of-contact load cells

Cantilever load-cells achieve repeatable, precise readings since there is no effect from an imbalanced load from a second point of reference. Load cells are duty-rated, provide a long, reliable service life and allows ingredient feeder or optional extruder output control to +/- 0.5%.



Positive position slide gates

Detents hold slide gates open to protect against vibration induced closure.



Rigid frame construction

Heavy-duty tubular steel frame resists bending and provides rigid structural stability to minimize vibration and aid precision dosing and blending.

Control Features

Designed for extruder operators with varying skill sets, intuitive input and recipe screens are laid out according to the extrusion process. Touch-button access to recipes, material usage, alarms, reports, and optionally to extruder output, line speed and weight-per-length. Built-in help screens walk you effortlessly through set-up and operations.

- PLC control with user friendly setup and control screens
- 7-inch touchscreen HMI (can be remote located)
- Full color, high visibility graphics
- Stores up to 250 recipes
- Built-in diagnostics / self-calibrating
- Material usage monitoring
- Remote communications: Modbus TCP, Ethernet IP
- Three levels of security passwords for limiting access
- Screen languages: English, Spanish, French, German, Chinese
- Loader control (seven [7] loaders and one [1] pump)
- Remote start/stop
- SMS or text message alarm capable
- Built-in Virtual Network Client (VNC). VNC allows remote Ethernet IP based monitoring and control within a private network.
- Fully configurable priority of hopper specific or system level alarms. Stores up to 100 alarms for recall.
- Material inventory, recipe and diagnostic reports. Automated reports can be sent direct to printer, USB or accumulated on memory stick.

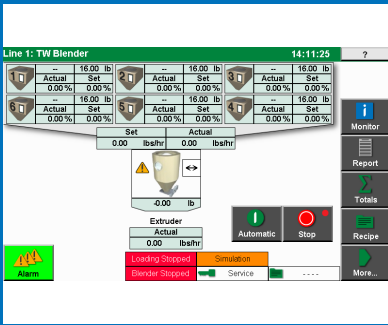

Home page
The blender home page shows all primary information including set point and actual values for component dosing percentages and blender output, weigh hopper fill weights, selected recipe and blender start-stop.

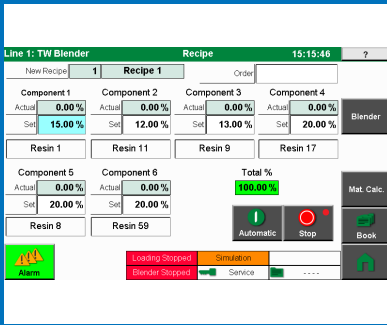

Recipe
The recipe screen offers very simple, intuitive operator inputs for each component position. Recipes can be input by job or selected from memory. The onboard recipe book can store up to 500 recipes for quick set up and assured repeatability.

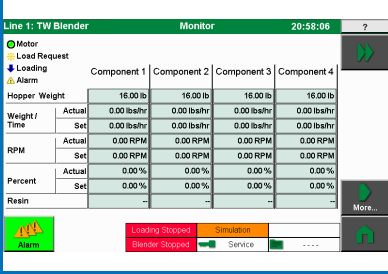

Monitor
Monitor screens are presented in an easy to read table format. Process variable settings are shown for each component position. Up and down arrows toggle through additional or prior positions.

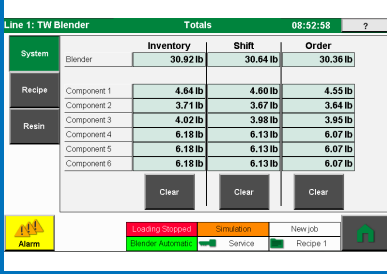

Totals
Instant access to cumulative material weights processed in total, by component position and by shift since last reset. Data is available for output to reporting software.

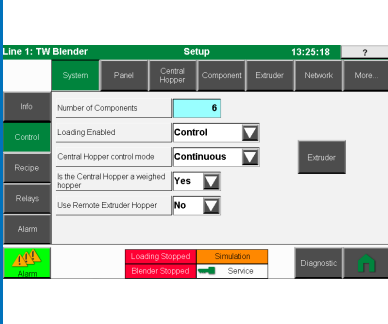

Setup
Setup touch button access for easy configuration of system and all components, as well as access to diagnostics, trend screens and maintenance.

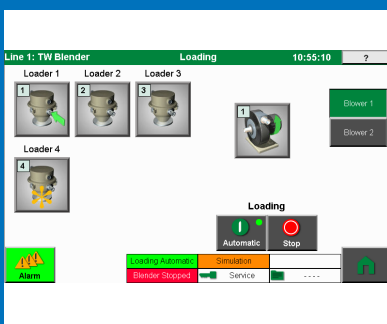

Loading
Familiar icons and simple-to-follow help instructions are used in the available loader control screen.

How it works: with Extrusion Control

TrueWeigh Continuous Blenders can control the extrusion process, as well as gravimetrically blend material. Throughput and haul-off control options allow you to:

- Monitor or control extruder throughput
- Monitor or control haul-off
- Monitor and control line haul-off and extruder throughput to provide yield control

Line control options include weight-per-length, weight-per-area and thickness; all as functions of length or weight-per-time.

TrueWeigh Continuous Blenders can control one mono-extrusion line consisting of a homogenous blend of up to six ingredients.

For co-extrusion lines, the optional TrueWeigh™ layer ratio control system supervises up to twelve extruders feeding a common die.

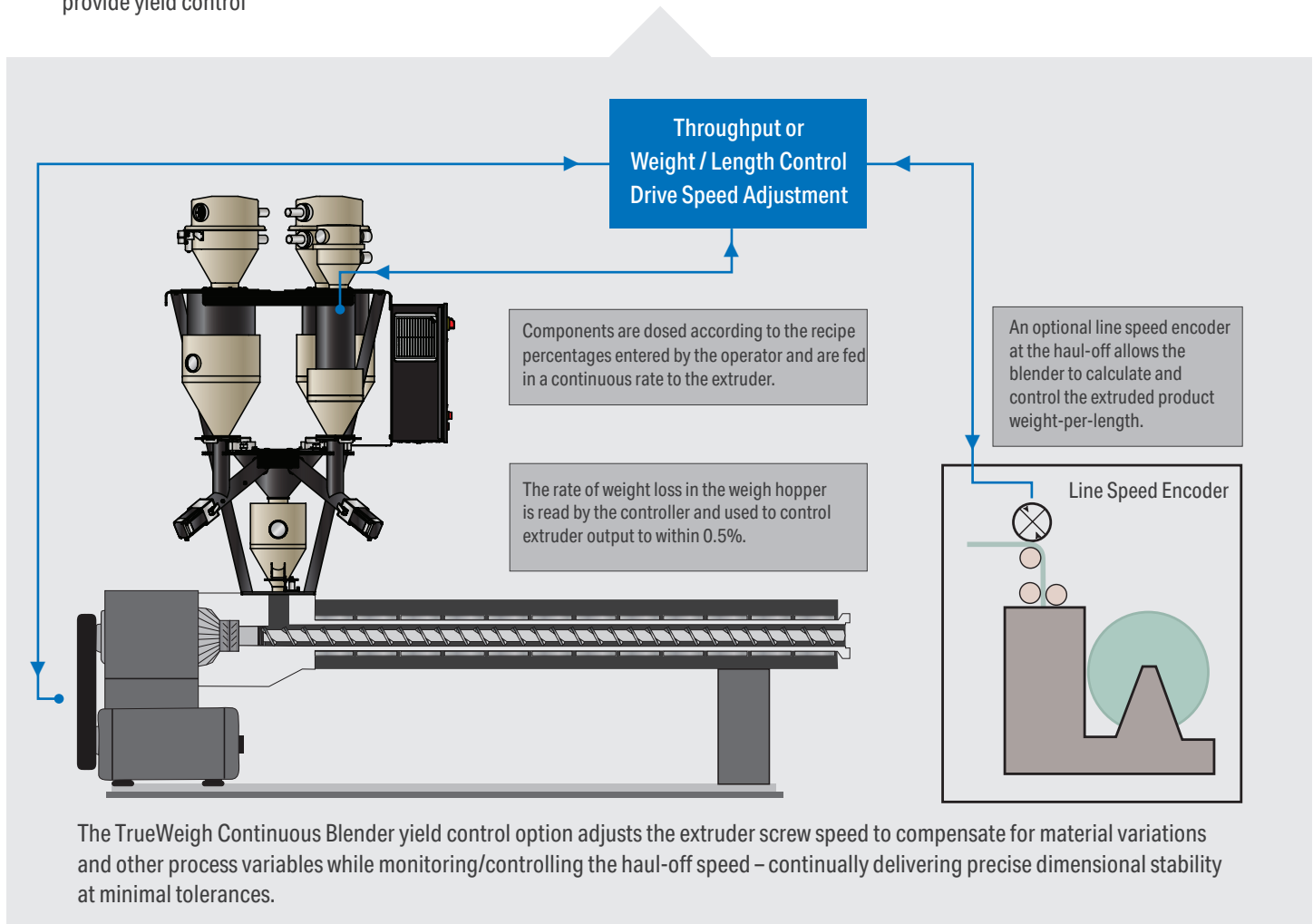

Options

- Powder feeder
- Regrind feeder
- Custom augers
- UL or cUL label on control panel
- Remote throat-mounted weigh hopper
- High temperature 350°F {177°C} operation
- Extension cable for remote control mount
- Stainless steel hoppers and material contact points
- Remote communications: Modbus Serial, Profibus, A-B DH+, CAN bus, DeviceNet
- CE approval
- Special paint
- Haul-off encoder
- Non-fused rotary disconnect
- Bumpless transfer of control (motorized potentiometer or signal isolator board or pulse encoder)
- Extruder and haul-off drive control cards - The drive control outputs are: 0-10 VDC, up/down interface and motorized potentiometer.

Specifications

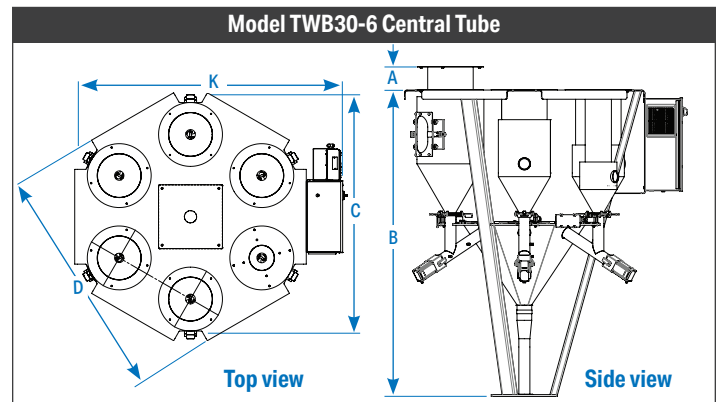
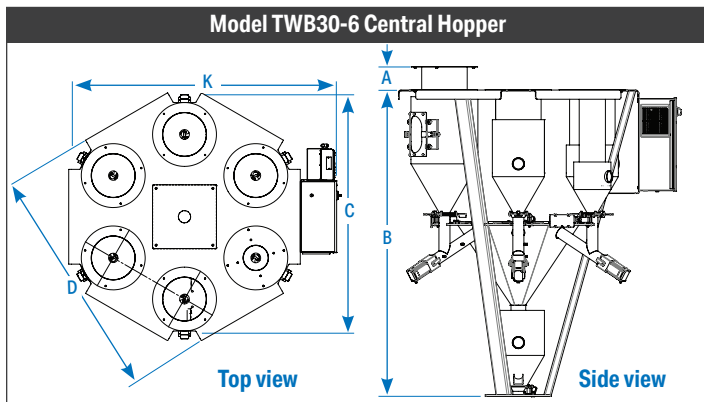
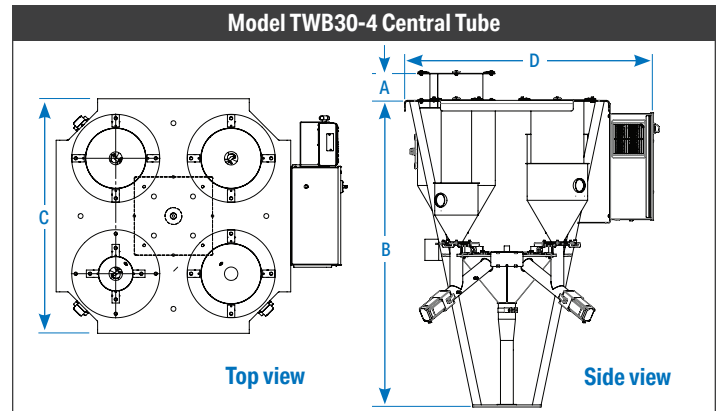
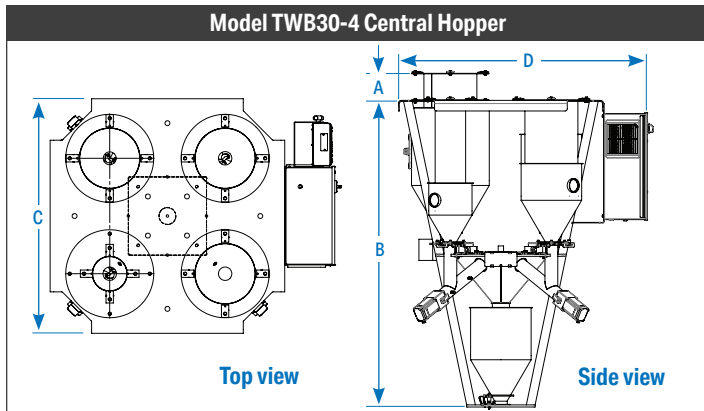
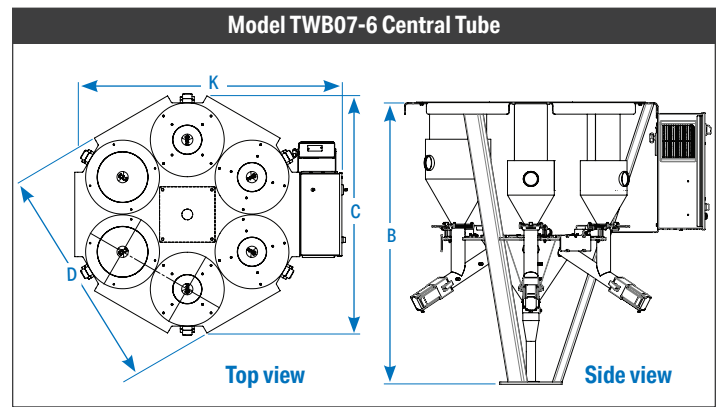
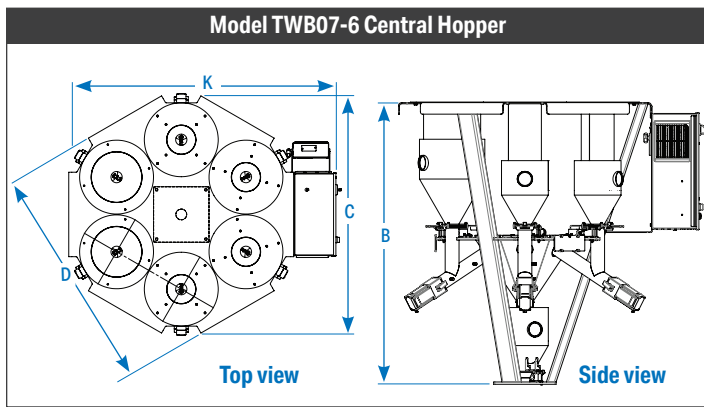
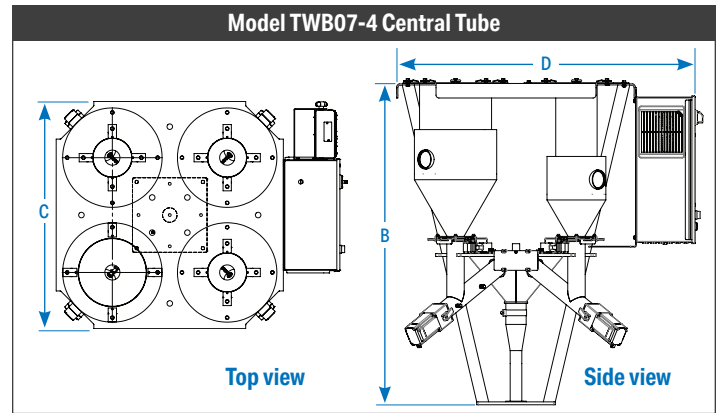
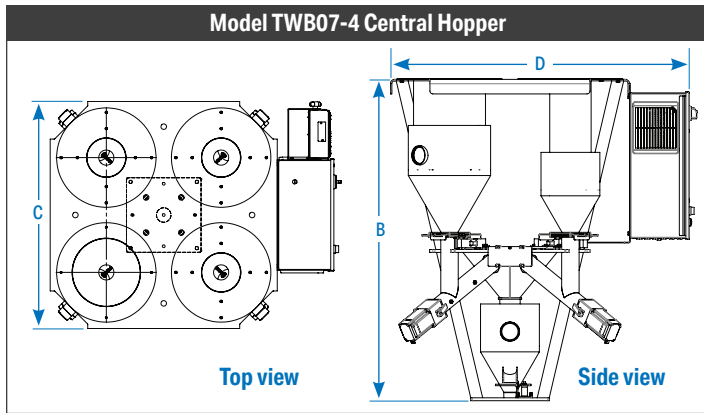

Specifications

Models	TWB07-4	TWB07-6	TWB30-4	TWB30-6
Performance characteristics				
Maximum throughput lbs (g)	700 {317}		3000 {1360}	
with central hopper*	700 {317}		3000 {1360}	
with central discharge tube [†]	2800 {1270}	4300 {1950}	12000 {5443}	18000 {8164}
Dimensions inches (mm)				
A - Riser height	N/A		6.4 {162.1}	
B - Height to loader mounting deck	55.3 {1403.4}	61.0 {1549.4}	72.3 {1835.2}	83.3 {2114.6}
C - Width	41.1 {1044.6}	57.8 {1467.9}	48.0 {1219.2}	69.9 {1775.1}
D - Depth	51.4 {1304.7}	54.8 {1392.9}	58.2 {1477.8}	65.3 {1657.9}
E - Control height			6.5 {165.1}	
F - Control width			8.8 {222.3}	
G - Control depth			6.8 {171.5}	
H - Mounting plate width (square)			13.5 {342.9}	
I - Mounting plate bolt pattern (square)			12.0 {304.8}	
J - Mounting plate center hole diameter			2.6 {66.7}	
K - Total depth 6 position model	N/A	65.1 {1653.1}	N/A	75.5 {1918.1}
Approximate weight lbs (kg)				
Installed with central weigh hopper	550 {249}	750 {340}	720 {326}	1050 {476}
Shipping with central weigh hopper	700 {317}	900 {408}	870 {394}	1200 {544}
Installed with central discharge tube	520 {235}	730 {331}	700 {317}	1020 {462}
Shipping with central discharge tube	680 {308}	880 {399}	850 {385}	1170 {530}
Electrical requirements Full load amps[§]				
115V/ 1 phase/ 60 Hz	15	20	15	20

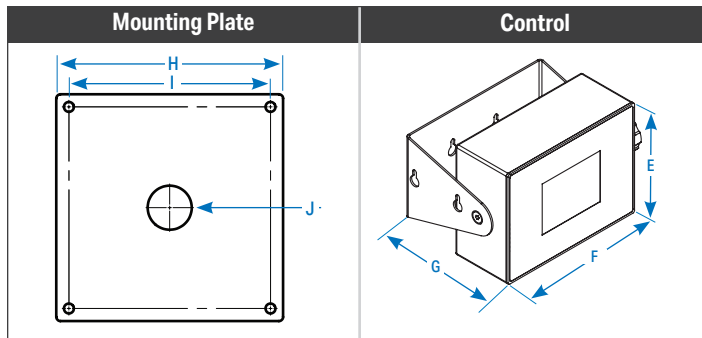

Specification Notes

- * Maximum throughput rate is limited to the throughput capacity of the central weigh hopper. Calculation is based on 35 lb/ft³ pelletized material.
- † Maximum throughput rate is for all positions configured with the largest available material hopper and the largest associated feed auger. Calculation is based on 35 lb/ft³ pelletized material.
- ‡ Any position can accept the largest hopper size available for the model size.
- § FLA data for reference purposes only. Does not include any options or accessories on equipment. For full FLA detail for power circuit design of specific machines and systems, refer to the electrical diagrams of the equipment order and the nameplate applied to the machine.

Specifications may change without notice. Consult with a Conair representative for the most current information.

Hopper and Loader Choices

Hopper Choices - (any position) [‡]	TWB07-4	TWB07-6	TWB30-4	TWB30-6
Hoppers				
3.4 ft ³ {96.3 liter}	N/A	N/A	•	•
1.7 ft ³ {48.1 liter}	N/A	N/A	•	•
1.0 ft ³ {28.3 liter}	•	•	•	•
0.3 ft ³ {8.5 liter}	•	•	•	•
Maximum Loader Sizes				
Hoppers				Loader Size
3.4 ft ³ {96.3 liter}				20-inch
1.7 ft ³ {48.1 liter}				15-inch
1.0 ft ³ {28.3 liter}				12-inch
0.3 ft ³ {8.5 liter}				8-inch

