

# Accurate Gravimetric Blending For Higher Throughputs

Get accurate blends, better mixing, faster material changes and increased profits with Conair's TrueBlend™ Series Blenders. Steep-sided component hoppers allow material to flow evenly and freely through vertical dispense valves into the weigh chamber. Efficient mixing assures full integration of all recipe ingredients.

The fully-enclosed cabinet assures no pellet spillage and clean operation. Standard convenient features such as wide access doors on each main material compartment, a hinged access door and removable components in the mixing chamber reduce downtime during cleanout.



**Model TB250-4**  
(Shown with optional  
Access Receivers.)

## Throughput Rates to 950 Pounds an Hour

The TrueBlend™ TB250 Series Blenders offer processors with medium-sized extruders or large tonnage injection molding machines a superior way to blend color and additives centrally or at the throat of the processing machine.

The blender dispenses up to six materials (depending on model) from material compartments into a common weigh chamber. The control determines the correct weight of each ingredient based on setpoints entered on the touch screen display. Up to 3000 recipes and 4000 resin names can be entered and stored in the control.

Unique fast-acting "no stick" vertical valves control the amount of material dispensed. All dispense valves use two-way air cylinders assuring positive operation.

Choose between four component or six component blender models. Options include an integrated loader control feature, a flow control valve for central blending applications and material compartment drain ports.

- ▶ **Blend accuracy to 1/2 of 1%**  
Colorant and/or additive weights are held to within 0.5% of setting. A selectable Precision Additive™ feature is also available for additives. The microprocessor control automatically calibrates after every cycle and compensates for variations in dispense method, resin bulk density or particle geometry.
- ▶ **Easy-to-use control**  
Intuitive 7-inch LCD touchscreen control with full color graphics allows quick and easy setup of blender setpoints. All setpoints are displayed simultaneously. Enter the percentages of the blend on the touchscreen display and the blender does the rest. The system automatically weighs the recipe ingredients in the proper sequence and maintains the correct blend relationship. Any position can be identified as one of the four material type selections adding flexibility to your application setup.
- ▶ **Convenient, easy clean out**  
Easy access to all material contact points for fast and safe cleaning during color or resin changes. Quick access material compartment bins, a removable weigh bin, mix agitator and mix chamber allow quick efficient cleaning. The blender features a built-in manual material shutoff valve below the mixing chamber, this can be replaced with the automatic flow control valve for remote and central blending applications.



# Features

## Intuitive, SB-5 touchscreen control offers the industry's best multi-component accuracy

This easy-to-use touchscreen control allows for fast setup of blender setpoints and automatically weighs recipe ingredients in the proper sequence to maintain correct blend relationship. Any position can be identified as any of the four material type selections, adding flexibility to your application setup.

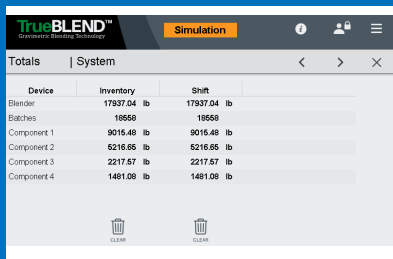

**Instantly see your materials usage**  
Material usage / totals screen tracks the number of batches, weights dispensed by bin and weight dispensed in total since the last reset.

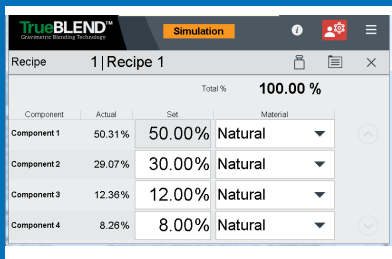

**View and make changes to the active recipe**  
Save and recall up to 3000 recipes and 4000 resin names in the Recipe Book.

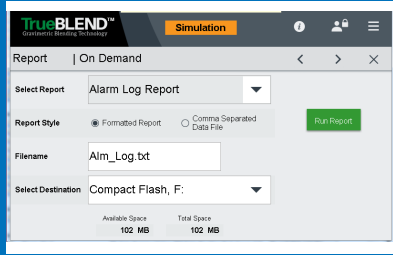

**Built-in reporting**  
Every SB-5 Blender control is equipped with the capability to help users track their settings, alarms, material consumption, shift and inventory needs.

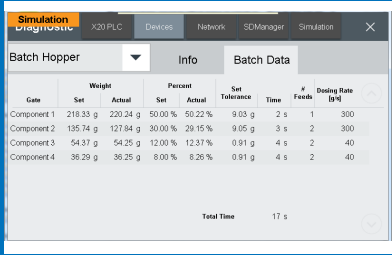

**On-call diagnostics**  
Diagnostic screen displays target set point percentage and actual percentage dispensed. Also displays start and finish weights for each material per batch. Verifies true and accurate blend performance.

## Which package is right for you?

Standard Packages - 4 Component	TS	TE	LS <sup>†</sup>	LE <sup>‡</sup>
<b>Features</b>				
Material bin sight glasses and clean out doors	•	•	•	•
Touchscreen control	•	•	•	•
Loading control option			•	•
Loader, pump and compressed air interconnection kit			•	•
Material bin finger guards	•	•	•	•
Quick clean/enhanced flow option*		•		•
Machine mount with manual slide gate discharge <sup>†</sup>	•	•	•	•
Remote/bin mount with pneumatic slide gate discharge <sup>†</sup>	•	•	•	•
<b>Standard Packages - 6 Component</b>	<b>TS</b>	<b>TE</b>	<b>LS<sup>†</sup></b>	<b>LE<sup>‡</sup></b>
<b>Features</b>				
Material bin sight glasses and clean out doors	•	•	•	•
Touchscreen control	•	•	•	•
Loading control option			•	•
Loader, pump and compressed air interconnection kit			•	•
Material bin finger guards	•	•	•	•
Quick clean/enhanced flow option*		•		•
Machine mount with manual slide gate discharge <sup>†</sup>	•	•	•	•
Remote/bin mount with pneumatic slide gate discharge <sup>†</sup>	•	•	•	•



No pellet leakage.  
No material waste.  
Completely sealed chassis.

**Feature Notes**

- \* Material bin door safety interlocks and drain ports.
- <sup>†</sup> Choose between either machine or remote mounted blender packages.
- <sup>‡</sup> Includes an optional integrated loader control feature.

Specifications may change without notice. Consult with a Conair representative for the most current information.



## Features

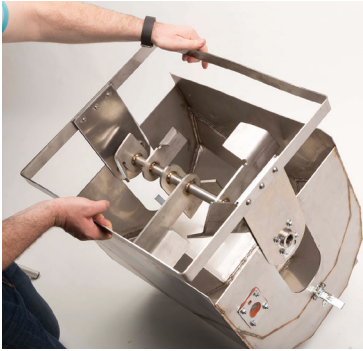

**Simple and quick cleanout**  
Mixing chamber and weigh bin are easily removed as single units, then the mix chamber comes apart for detailed cleaning. All with no tools in record time.

**Optional floor stand with reservoir**  
Provide blending beside the machine or remotely with a rugged, mobile floor stand, equipped with a blended material reservoir.

Each blender stand features:

- Sturdy design
- Easy cleanout
- Fork-lift provisions
- Drawer magnet provision
- One standard material takeaway tube (up to two additional material tubes are available as options)
- Available with two or five cubic foot reservoir capacities



## Options



Standard Bin



Tapered Bin

### Standard bin or Tapered bin

While the Standard mixing chamber is suitable for a wide variety of applications, the Tapered mixing chamber is ideal for critical application blends with material percentages less than 1%. The tapered design allows for improved mixing.



### Dry air blanket

This option blankets the material compartments and mixing chamber with hot dry air to prevent moisture regain during processing. Available on both the TBA and TBH models. See TBA and TBH specification sheet.



### Material level alarm control

Eliminate costly material shortage problems and machine downtime with this early warning system. The control monitors up to six material levels. Each sensor can be set as a high or low warning. See Level Alarm Control specification sheet.



### TrueBlend High-heat Models

Used to blend high temperature plastics such as ABS, nylon, polycarbonate and PET resins.

- Medium temperature (160° - 250°F {71° - 121°C}) TBA models.
- High temperature (250° - 375°F {121° - 191°C}) TBH models. See TBA and TBH specification sheet.



### Air blow-off for mix chamber level sensor

This feature is integrated into the blender mix chamber to blow excessive dust and fines away from the mixing chamber sensor and ensure accurate level sensor reading.



### Remote mixer demand sensor

This sensor provides a fill-to level option in a surge bin or other material receptacle that sits below a remote mounted blender.



### Remote HMI operator cable

Place the TrueBlend control up to six meters away with convenient plug-in cable set.



### Drain chute

For fast, safe, thorough and simple blender draining prior to cleanout. The drain chute quickly installs over the blender front opening.



### Major component flow restrictor

Generally used when feeding more than two minor ingredients.



### Minor component flow restrictor

Generally used when feeding 1% or less of an ingredient.

# Specifications

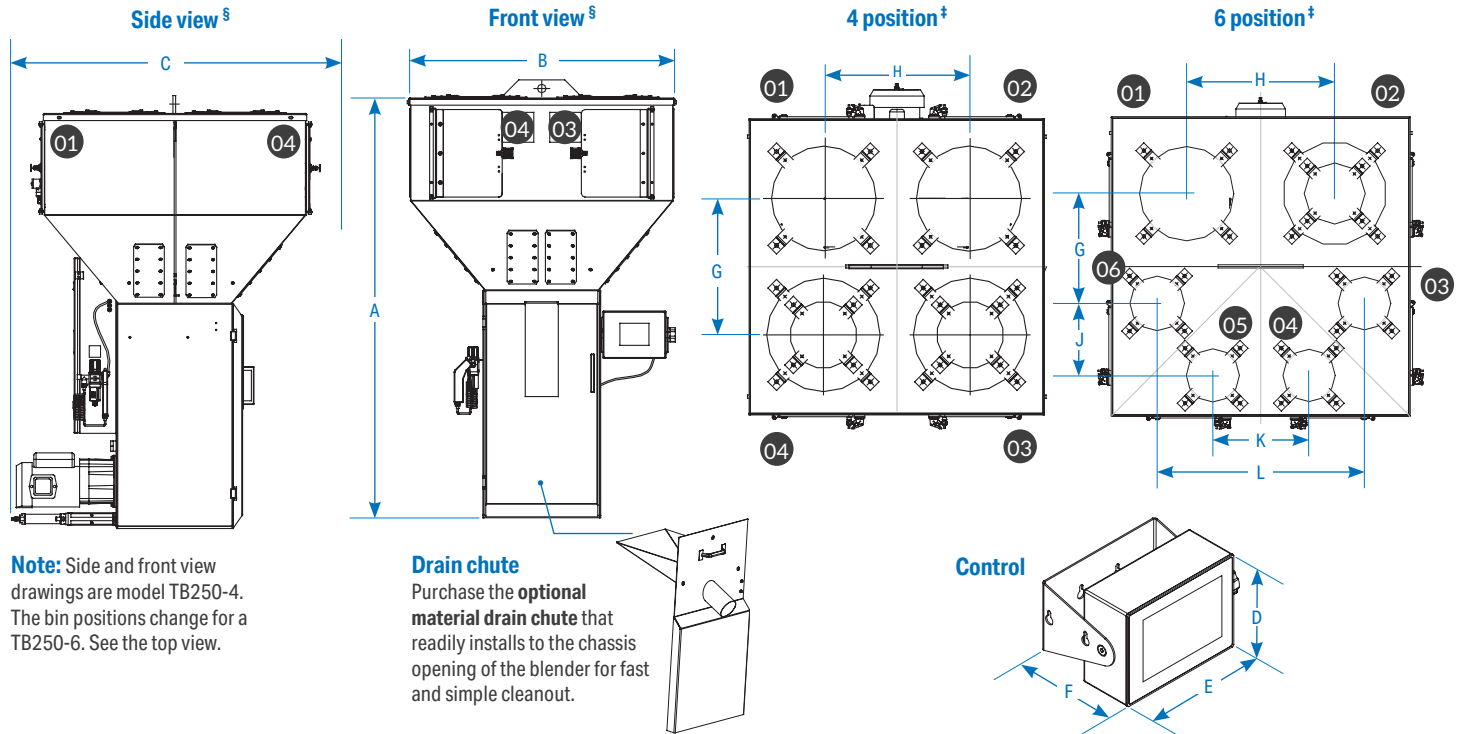

**Note:** Side and front view drawings are model TB250-4. The bin positions change for a TB250-6. See the top view.

**Drain chute**  
Purchase the **optional material drain chute** that readily installs to the chassis opening of the blender for fast and simple cleanout.

Models	TB250-4	TB250-6
<b>Performance characteristics</b>		
Batch size lbs (g)	5.5 {2500}	
Maximum throughput lbs/hr {kg/hr}*	950 {431}	750 {340}
Bin capacity - main ingredient ft <sup>3</sup> {liter}	1.6 {45}	2.7 {76}
Bin capacity - minor ingredient ft <sup>3</sup> {liter}	1.6 {45}	1.4 {40}
Maximum number of materials	4	6
Number of vertical discharge valves	4	6
Number - (size) of major bin valves	2 - (60 mm)	
Number - (size) of minor bin valves	2 - (30 mm)	4 - (30 mm)
<b>Dimensions inches (mm)</b>		
A - Height above mounting plate <sup>§</sup>	57.50 {1461}	63.0 {1600}
B - Hopper width and depth (square)	36.50 {926}	40.13 {1026}
C - Depth	40.83 {1037}	42.67 {1084}
D - Control height	6.50 {165}	
E - Control width	8.75 {222}	
F - Control depth	6.75 {172}	
G - Loader center distance	21.81 {554}	14.88 {378}
H - Loader center distance	20.13 {511}	20.0 {508}
J - Loader center distance	N/A	9.75 {248}
K - Loader center distance	N/A	13.00 {330}
L - Loader center distance	N/A	28.00 {711}
<b>Approximate weight lbs {kg}</b>		
Installed	320 {145}	400 {182}
Shipping	440 {200}	520 {236}
<b>Voltage Full load amps**</b>		
115V/1 phase/60 hz	6.3	
230V/1 phase/50 hz	3.2	
<b>Compressed air requirements</b>		
Discharge Valves	90 psi @ 0.2 ft <sup>3</sup> /min {6 bars @ 0.09 liters/sec}; 1/4 inch NPT fitting	
<b>Maximum loader sizes</b>		
15-inch loaders	4	2
8-inch loaders	N/A	4

**Application Notes** Dimensions shown in inches and (mm).

Mixing chamber access door - this side of the interface

Mounting bolt hole size (8 holes) 9/16 inch {14.0 mm}.  
Predrilled 8 x 8 and 12 x 12 mounting pattern as standard.

**Specification Notes**

- \* Maximum throughput rates are based on 35 lb/ft<sup>3</sup> pelletized material, using all standard valve sizes. Use of reducer inserts will lower the rate shown. Throughput rates are based on:
  - A 4-position blender recipe of 20% regrind, 80% natural, 3% color and 2% additive material.
  - A 6-position blender recipe of 20% regrind, 80% natural, 3% color at position 3, 2% additive at position 4, 3% additive at position 5 and 2% additive at position 6.
- <sup>†</sup> The optional automatic flow control valve is recommended when mounting inside the chassis in the space of the manual slide valve. Conair recommends using the optional flow control valve when mounting the blender on a stand, surge bin or hopper.
- <sup>‡</sup> TB250-4 hopper positions two and four are supplied with 12-8 adapters with eight inch cover plates as standard. TB250-6 hopper position two is supplied with a 12-8 adapter with an eight inch cover.
- <sup>§</sup> Numbers in top view drawings represent hopper positions.

\*\* FLA data for reference purposes only. Does not include any options or accessories on equipment. For full FLA detail for power circuit design of specific machines and systems, refer to the electrical diagrams of the equipment order and the nameplate applied to the machine.

Specifications may change without notice. Consult with a Conair representative for the most current information.

