

Accurate Gravimetric Blending for Very Large Extruders

Get accurate blends, better mixing, faster material changes and increased profits with Conair's TrueBlend™ Series Blenders. Steep-sided component hoppers allow material to flow evenly and freely through vertical dispense valves into the weigh chamber. Efficient mixing assures full integration of all recipe ingredients. The fully-enclosed cabinet design assures no pellet spillage and clean operation. Standard convenient features such as wide access doors on each main material compartment, a hinged access door and full access to the mixing chamber reduce downtime during cleanout.



Model TB3500-6
(Shown with (2) DL25
and (4) DL20 vacuum
receivers.)

Throughput Rates to 12000 Pounds an Hour

The TrueBlend™ TB3500 series blenders offer processors with large extruders or central blending applications a superior way to blend naturals, regrinds and additives centrally or at the throat of the processing machine.

The blender dispenses up to six materials (depending on model) from respective material compartments into a common weigh chamber. The control determines the correct weight of each ingredient based on setpoints entered on the touchscreen display. Up to 3000 recipes and 4000 resin names can be entered and stored in the control.

Air solenoids and major electrical components are easy to access through the electrically interlocked main power box.

Choose between four, five or six component blender models. Options include an integrated blender/loader control feature, a flow control valve for central blending applications, material compartment drain ports, and Ethernet communications.

▶ Blend accuracy to 1/2 of 1%

Colorant and/or additive weights are held to within 0.5% of setting. A selectable Precision Additive™ feature is also available for additives. The microprocessor control automatically calibrates after every cycle and compensates for variations in dispense method, resin bulk density or particle geometry.

▶ Easy-to-use control

Intuitive 7-inch LCD touchscreen control with full color graphics allows quick and easy setup of blender setpoints. All setpoints are displayed simultaneously. Enter the percentages of the blend on the touchscreen display and the blender does the rest. The system automatically weighs the recipe ingredients in the proper sequence and maintains the correct blend relationship. Any position can be identified as one of the four material type selections adding flexibility to your application setup.



▶ Convenient, no-tools clean out

Easy access to all material contact points for fast and safe cleaning during color or resin changes. Material compartment access doors and removable weigh bin allow quick efficient cleaning. The blender can have a built-in material shut-off valve below the mixing chamber or this can be replaced with the automatic flow control valve for remote and central blending applications.

Features

Intuitive, SB-5 touchscreen control offers the industry's best multi-component accuracy

This easy-to-use touchscreen control allows for fast setup of blender setpoints and automatically weighs recipe ingredients in the proper sequence to maintain correct blend relationship. Any position can be identified as one of the four material type selections adding flexibility to your application setup.

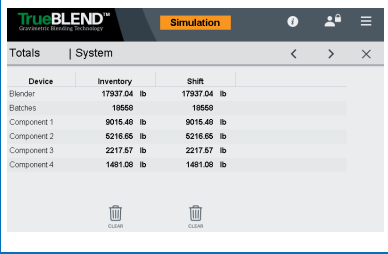

Instantly see your materials usage
Material usage / totals screen tracks the number of batches, weights dispensed by bin and weight dispensed in total since the last reset.

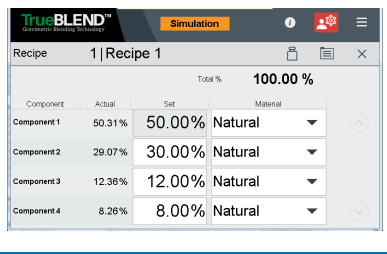

View and make changes to the active recipe
Save and recall up to 3000 recipes and 4000 resin names in the Recipe Book.

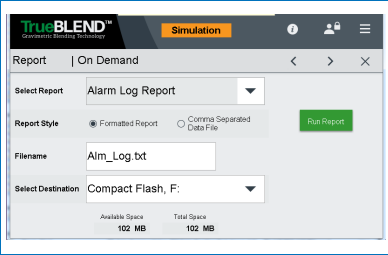

Built-in reporting
Every SB-5 blender control is equipped with the capability to help users track their settings, alarms, material consumption, shift and inventory needs.

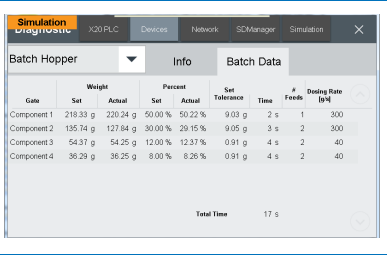

On-call diagnostics
Diagnostic screen displays target set point percentage and actual percentage dispensed. Also displays start and finish weights for each material per batch. Verifies true and accurate blend performance.

Which package is right for you?

Standard Packages - 4 Component	TS	TE	LS [†]	LE [‡]
Features				
Material bin sight glasses and clean out doors	•	•	•	•
Touchscreen control	•	•	•	•
Electrical material bin door interlocks	•	•	•	•
Loading control option			•	•
Loader, pump and compressed air interconnection kit			•	•
Quick clean/enhanced flow option*		•		•
Machine mount with manual slide gate discharge [†]	•	•	•	•
Remote/bin mount with pneumatic slide gate discharge [†]	•	•	•	•
Standard Packages - 5 Component	TS	TE	LS[†]	LE[‡]
Features				
Material bin sight glasses and clean out doors	•	•	•	•
Touchscreen control	•	•	•	•
Electrical material bin door interlocks	•	•	•	•
Loading control option			•	•
Loader, pump and compressed air interconnection kit			•	•
Quick clean/enhanced flow option*		•		•
Machine mount with manual slide gate discharge [†]	•	•	•	•
Remote/bin mount with pneumatic slide gate discharge [†]	•	•	•	•
Standard Packages - 6 Component	TS	TE	LS[†]	LE[‡]
Features				
Material bin sight glasses and clean out doors	•	•	•	•
Touchscreen control	•	•	•	•
Loading control option			•	•
Loader, pump and compressed air interconnection kit			•	•
Material bin finger guards	•		•	
Quick clean/enhanced flow option*		•		•
Machine mount with manual slide gate discharge [†]	•	•	•	•
Remote/bin mount with pneumatic slide gate discharge [†]	•	•	•	•



Feature Notes

- * Material bin door safety interlocks and drain ports.
- † Choose between either machine or remote mounted blender packages.
- ‡ Includes an optional integrated loader control feature. Specifications may change without notice. Consult with a Conair representative for the most current information.



Features

Simple and quick cleanout

Easy access to all material contact points for fast and safe cleaning during color or resin changes. Material compartment access doors allow quick efficient cleaning.

Custom stands available

Each blender stand features:

- Application specific modular construction
- One or two level designs
- Designs to accommodate low overhead clearances
- Available in Conair beige with standard safety yellow handrails and optional ladders

Options



Air blow-off for mix chamber level sensor

This feature is integrated into the blender mix chamber to blow excessive dust and fines away from the sensing device and ensure accurate level sensor reading.



Remote HMI operator cable

Place the TrueBlend control up to six meters away with convenient plug-in cable set.



Remote mixer demand sensor

This sensor provides a fill-to level option in a surge bin or other material receptacle that sits below a remote mounted blender.



Material level alarm control

Eliminate costly material shortage problems and machine downtime with this early warning system. The control monitors up to six material levels at one blender. Individual switches can be adjusted to monitor high or low material levels. See Level Alarm Control specification sheet.

TB3500-4, TB3500-5 AND TB3500-6

Specifications

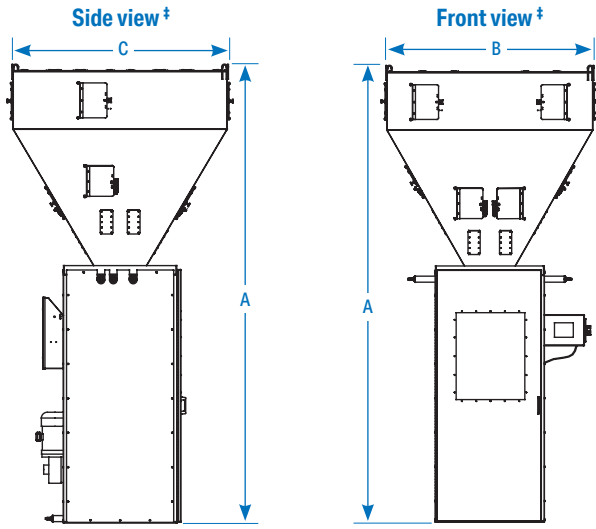

Note: Side and front view drawings are shown for model TB3500-6. The bin positions change for a TB3500-4 and TB3500-5 models, see the top view.

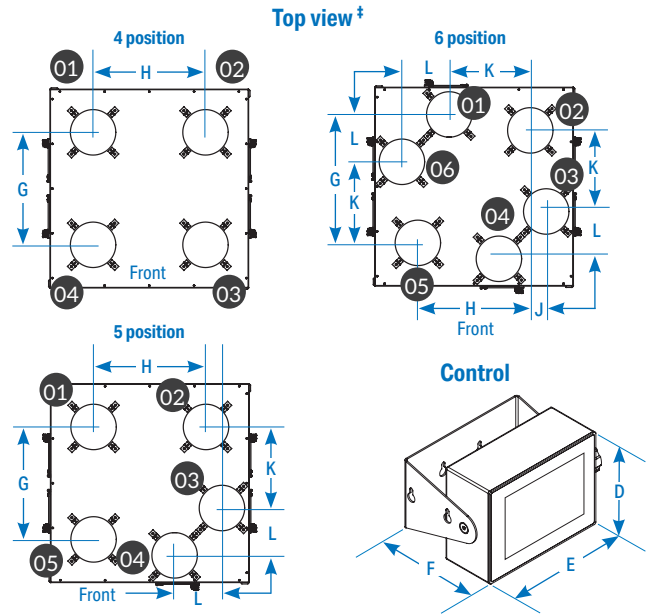

Models	TB3500-4	TB3500-5	TB3500-6
Performance characteristics			
Batch size lbs (g) (grams or kilograms)		77 {35000}	
Maximum throughput lbs/hr {kg/hr}*	12000 {5443}	10500 {4763}	9000 {4082}
Bin capacity - main ingredient ft ³ {liter}		18 {510}	
Bin capacity - minor ingredient ft ³ {liter}	18 {510}	9 {255}	
Maximum number of materials	4	5	6
Number of major valves	4 (6 x 6)	3 (6 x 6)	2 (6 x 6)
Number of minor valves	0	2 (2 x 6)	4 (2 x 6)
Dimensions inches (mm)			
A - Height above mounting plate†		156 {3962}	
B - Hopper width and depth (square)		72 {1828}	
C - Depth		72 {1828}	
D - Control height		6.50 {165}	
E - Control width		8.75 {222}	
F - Control depth		6.75 {172}	
G - Loader center distance		35.75 {908}	
H - Loader center distance		35.75 {908}	
J - Loader center distance	N/A	10.5 {267}	
K - Loader center distance	N/A	26.13 {664}	
L - Loader center distance	N/A	20.0 {508}	
Weight lbs (kg)			
Installed	2982 {1353}	3049 {1383}	3115 {1413}
Shipping	3282 {1489}	3349 {1519}	3415 {1549}
Voltage Full load amps[§]			
240V/3 phase/60 hz		10.3	
400V/3 phase/50 hz		7.7	
480V/3 phase/60 hz		6.4	
575V/3 phase/60 hz		5.6	
Compressed air requirements			
	0.3 ft ³ /min @ 90 psi {6 bars @ 0.14 liters/sec} 3/8 inch NPT fitting		
Maximum loader sizes			
Number of 25-inch loaders	4	5	6

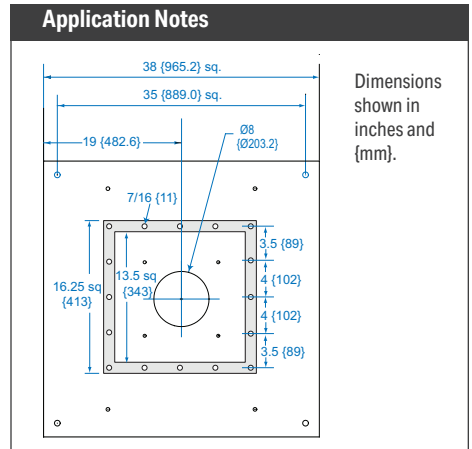

Specification Notes

- * Maximum throughput rates are based on 35 lb/ft³ pelletized material, using all standard valve sizes. Use of reducer inserts will lower the rate shown. Throughput rates are based on:
 - A 4-position blender recipe of 50% natural, 40% natural, 5% additive material and 5% additive material.
 - A 5-position blender recipe of 50% natural, 20% natural, 20% natural, 5% additive material and 5% additive material.
 - A 6-position blender recipe of 50% natural, 20% natural, 10% natural, 10% natural, 5% additive material and 5% additive material.
- † The optional flow control valve will mount inside the chassis in the space of the manual slide valve. Conair recommends using the optional flow control valve when mounting the blender on a stand, surge bin or hopper.
- ‡ Numbers in top view drawings represent hopper positions.
- § FLA data for reference purposes only. Does not include any options or accessories on equipment. For full FLA detail for power circuit design of specific machines and systems, refer to the electrical diagrams of the equipment order and the nameplate applied to the machine. Specifications may change without notice. Consult with a Conair representative for the most current information.

