

Efficiently Combine Two Materials While Loading

Externally mounted Ratio Valves connect readily to Conair vacuum receivers and loaders equipped with ratio-capable controls.

The dual inlets alternately open and close in response to a timed control signal, providing a mix of virgin and regrind materials during each vacuum loading cycle.

At rest, the regrind side is open and the virgin inlet is closed, allowing the valve to isolate the receiver from the common material line of central systems.



RV-2 Ratio Valve

Automatically Load Regrind as it is Generated

The Conair Ratio Valve may be readily used as a dual inlet to single outlet valve for a variety of material conveying applications.

Standard model ratio valves have aluminum inlets and outlets and can be used with materials up to 225°F {107°C}.

An optional high performance version of the Ratio Valve is available. It is optimized for use with high temperature materials, those exceeding 225°F {107°C}, and for highly abrasive materials including glass filled resins and sharp regrind.

- ▶ **Modular design**
Screw-in components allow common wear parts to be easily replaced and line sizes to be changed without the need of purchasing another valve.
- ▶ **Smooth aluminum body**
A non-corrosive, smooth path for material flow.
- ▶ **Easy to clean**
Removable with no tools, the lid provides wide open access.
- ▶ **High performance option**
Optimized for use with high temperature and/or highly abrasive materials.

Specifications

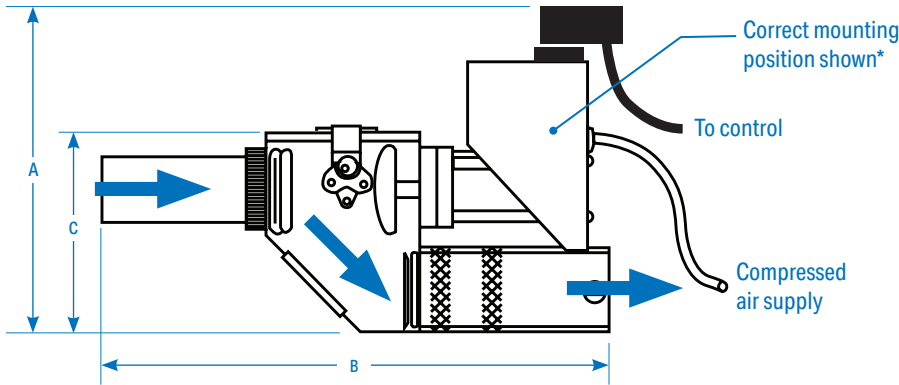

Application Notes

Ratio Valves alternate between virgin and regrind materials based on time. No provisions are made for confirmation of material flow, conveying rate or compensation for variations in bulk density. Ratio Valves are ideally suited for applications where 100% of generated regrind may be safely reintroduced to the process.

Model	RV-1	RV-2	RV-3	RV-4
Performance characteristics				
Line size diameter inches	1.5 - 2	2.25 - 2.5	3	4
Type of inlet/outlet connection	screw-in		welded	
Body type aluminum	cast		fabricated	
Dimensions inches (mm)				
A - Overall height	9.5 {241}	10.5 {267}	13.0 {330}	
B - Length	12.5 {318}		13.25 {337}	
C - Width	4.75 {121}	7.0 {179}	8.0 {203}	
Approximate weight lb {kg}				
Installed	10 {5}	13 {6}	17 {8}	
Shipping	14 {6}	17 {8}	21 {10}	
Voltage Full load amps				
120V/1 phase/60 Hz			0.25	
24V/1 phase/50 or 60 Hz			1.0	
Compressed air requirement				
Air consumption	0.2 ft ³ /min. @ 80 psi { 0.09 liters/sec @ 5.5 bars}			
Hose requirement	1/4 inch hose fitting			

Specification Notes

* Valves are to be mounted horizontally only.
 † FLA data for reference purposes only. Does not include any options or accessories on equipment. For full FLA detail for power circuit design of specific machines and systems, refer to the electrical diagrams of the equipment order and the nameplate applied to the machine.
 Specifications may change without notice. Consult with a Conair representative for the most current information.

Options

- Dual solenoid**
 This special Ratio Valve option allows both material inlets to be normally closed for dual common material line operation.
- High performance**
 The high performance Ratio Valve has stainless steel inlets and outlets, includes high temperature Viton seals in the pneumatic cylinders, specially plated and heat-treated valve body, lid and plungers for maximum wear resistance.
- Ratio Valve as a material selector** A simple A/B toggle switch selects which material inlet is open, for easy selection between two material lines. (120V/1phase/60 @ 2 amps.)
- Add ratio loading capability**
 Any 120 Volt single inlet loader may be converted to ratio operation with this control. The control uses the vacuum loading signal to create timed virgin and regrind signals.

