

Modular Construction for Easy Expansion

Because Conair's Bulk Distribution Boxes are modular; material outlets may be added as your needs grow. Any module may be directed towards your material destination to assure the easiest possible line routing. The box modules are the industry standard 16-inch square bolt pattern and allow for a wide variety of line sizes, draining and easy cleanout options.

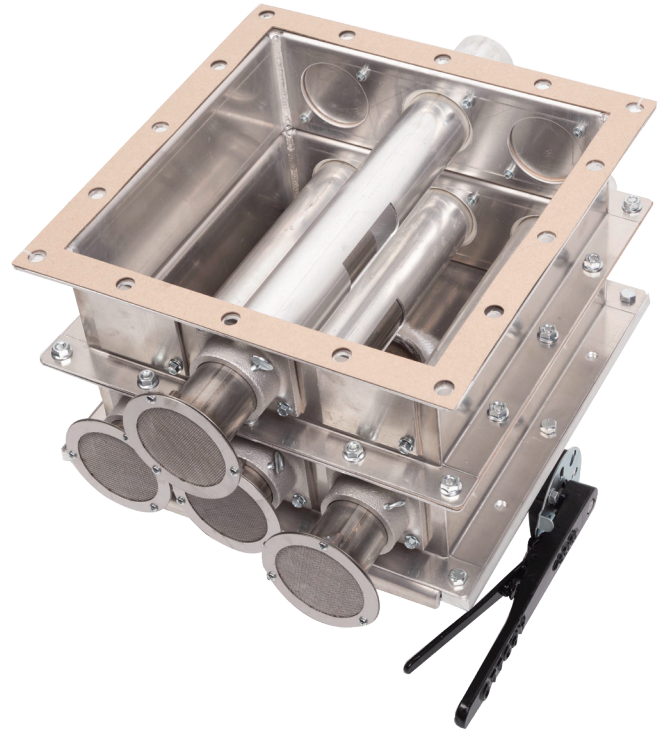

Trouble-Free Material Flow to Multiple Destinations

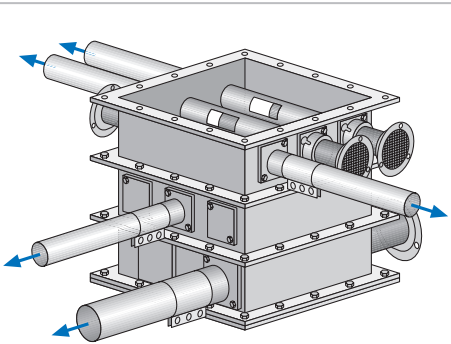

Distribution Box modular layers may be independently specified and oriented in any direction.

- **Aluminum and stainless steel construction***
For years of trouble-free performance.
- **Easy air-to-material ratio adjustment**
To prevent material from surging, starving or jamming.
- **May be hard piped**
No need for flex hose.
- **Modular, expandable**
Additional outlets may be added when needed.

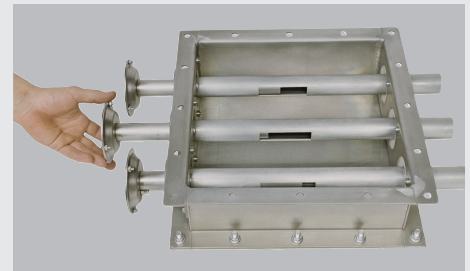

* All stainless steel construction is optional.

Features / Options

Smooth Material Flow

Conair Distribution Boxes assure smooth material flow with hand adjustable slip tubes that ratio the amount of material to be conveyed in proportion to the inlet air used for vacuum conveying. This way, material jamming, slugging or starving is minimized. The sliding air inlet tube is fitted with a filter screen to prevent unwanted debris from entering the conveying system, or material from leaving the distribution box.

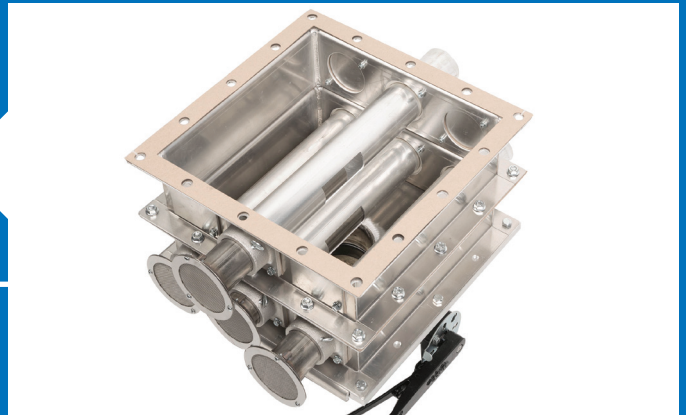

Typical Distribution Box Feed Tube

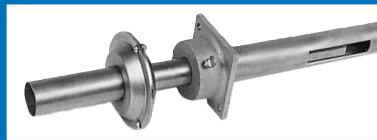
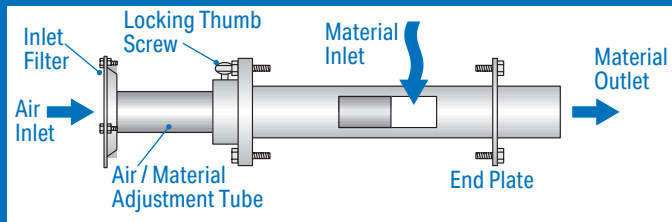

For dry air conveying systems, the air inlet is fitted with an optional tubing adapter that may be plumbed to the dry air source.

Optional Cartridge Filter

Quick Cleanout

Add any of these options directly to the base of your material vessel or below any Distribution Box Modules.



The SB Module (shown here) is perfect for frequent material change overs. Equipped with up to three material outlets plus a drain port (with slide gate), the hinged bottom may be hand released after draining and the round bottom wiped clean. For close clearance installations, where there is not enough room for the swing down chamber, the single outlet RB Module (not shown), also with a round bottom, may be bolted in place.

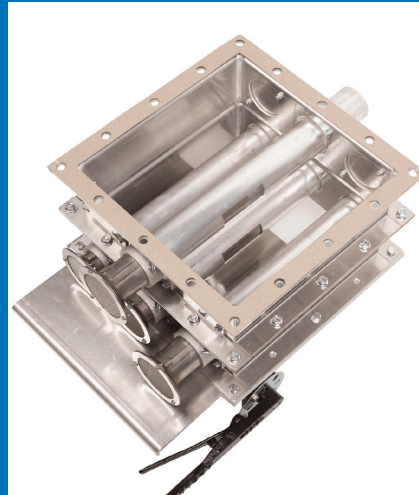

This Slide Bottom Plate allows full access to the underside of your bin and the inside of the Distribution Box for fast, easy cleaning and inspection (not recommended for partial draining of the bin).

Easy Drain



Transition with Valve is designed for manual filling of gaylords or barrels and assures full draining with no dead spots and easy on/off flow control.



Slide Bottom with Valve allows you to drain material then slide the bottom open for thorough cleanout and inspection. The valve plate is also available in a nonslide version.

Accessories

Angel Hair Removal

Trap material clogs before they clog your conveying system

"Angel hair", "streamers", or "skins", created by high-velocity conveying of soft material, can clog your conveying system by blocking distribution box tubes or creating material bridges in hoppers. Conair's Angel Hair Remover provides a stainless steel screen in the material flow path to filter out the clogging material and allow it to be easily removed from the system. Usually fitted at the base of a silo or storage bin, the Angel Hair Remover should be installed below a Conair Slide Gate (see below) and above your main Distribution Box. The unit fits the same 16-inch square bolt pattern as Conair's entire line of Distribution Box components and requires only 8.5 inches of height.

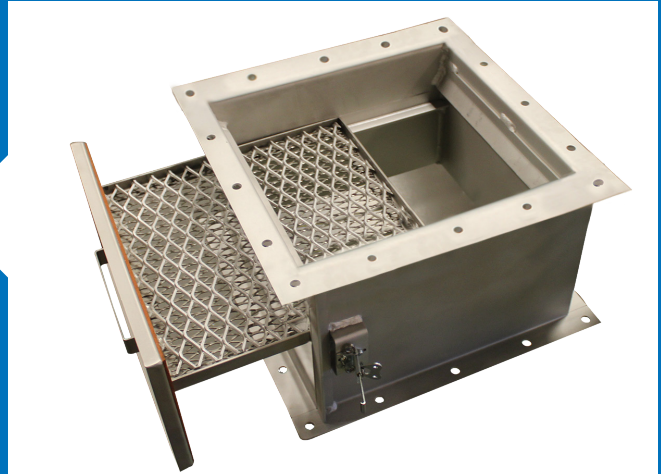

The easy-to-clean Angel Hair Remover, 101-625-01.
Height 8.5 inch {216 mm}

A low-profile version is also available. #220122L010P01

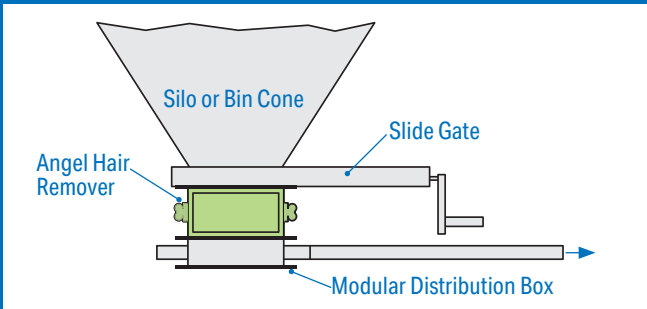

Slide Gate

To stop the flow of material from a bulk storage vessel, Conair's Slide Gate provides a heavy-duty hand crank that allows the stainless steel knife gate to cut through a solid column of material and stop material flow for service, cleaning or equipment changes. The rugged housing requires mini below your silo and is constructed of aluminum, with an all stainless steel mechanism. Available in both round and square top flanges to fit both popular vessel outlet flanges, the bottom flange is the industry standard 16-inch square bolt pattern to allow fitting any of Conair's extensive line of Bulk Distribution Box products.

Slide Gate #140-124 Height 7.25 inch {184 mm} (for square bottom bins)

A low-profile version is also available. #126011

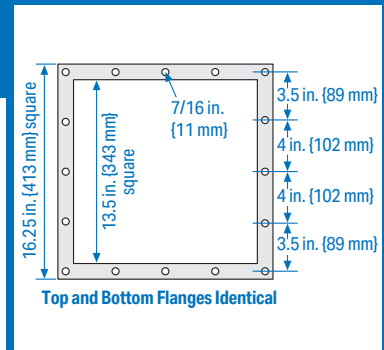
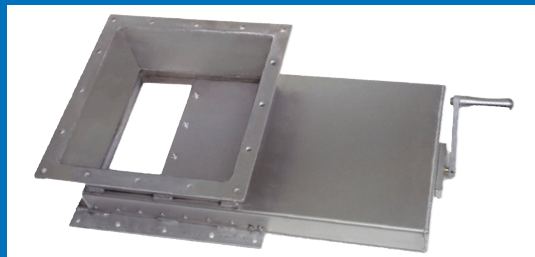

Slide Gate #140-077 Height 7.25 inch {184 mm} (for round bottom silos)

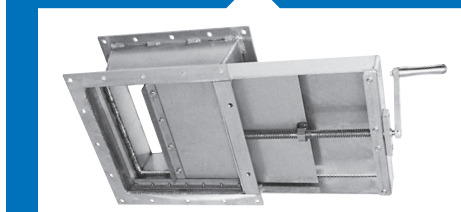
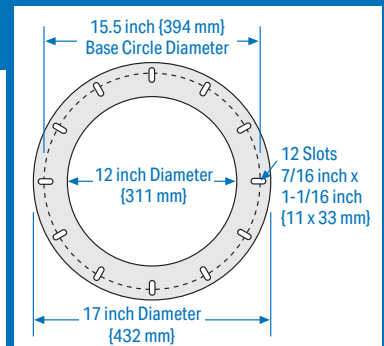
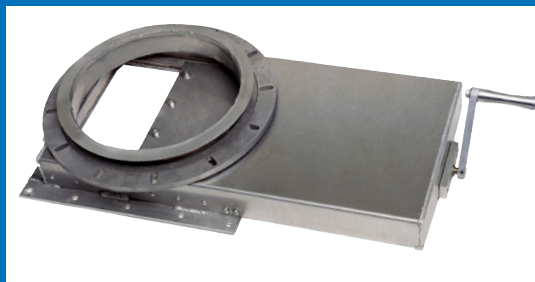

Specifications

| Fits in Feed Tube Kit (OD) | Port Size |
|----------------------------|-----------------|
| 1.5 inches (38 mm) | Small port size |
| 1.75 inches (45 mm) | Small port size |
| 2 inches (51 mm) | Small port size |
| 2.25 inches (57 mm) | Small port size |
| 2.5 inches (64 mm) | Small port size |
| 3 inches (76 mm) | large port size |
| 4 inches (102 mm) | large port size |

Application Notes

When using a multi-outlet distribution box directly below a vessel with a material outlet diameter under 8 inches, use box modules DA or DB to assure adequate material flow to the outside tube positions.

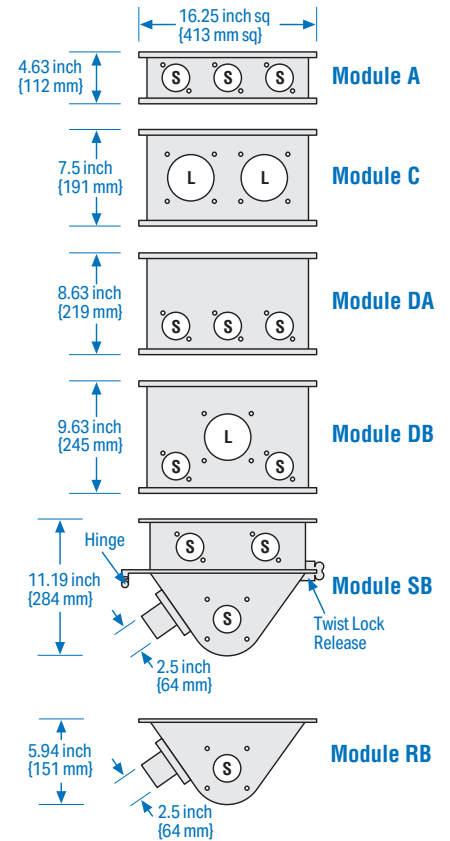
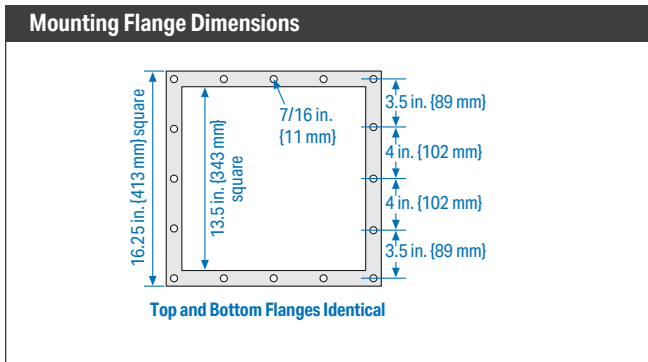

Other Models

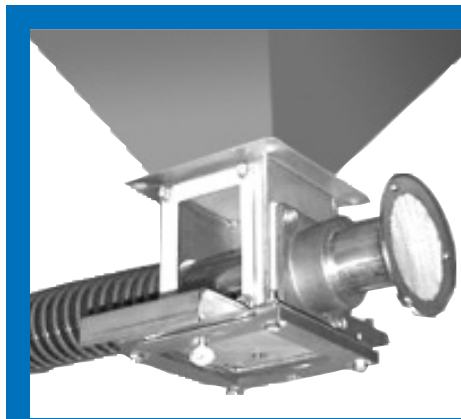

For compact material conveying systems requiring only a single material outlet, Conair's Single Tube Boxes are ideal. Built entirely out of stainless steel, these boxes fit easily onto small bin outlets with a 5" x 5" square bolt pattern. Each model includes a quick drain/easy clean slide gate in the bottom, plus an air inlet screen filter and a sight glass. Air-to-material adjustments are made in the same precise fashion as Conair's line of larger Bulk Distribution Boxes.

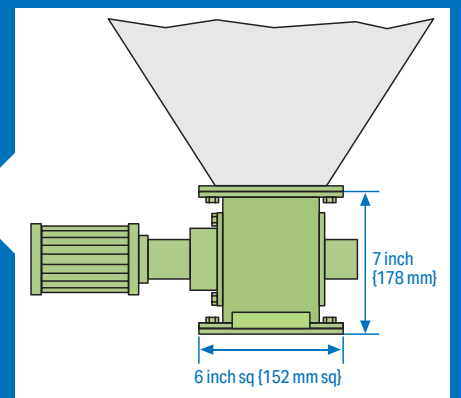

| Material Outlet (OD) | Box Part Number |
|----------------------|-----------------|
| 1.50 inches (38 mm) | 101-631-01 |
| 1.75 inches (45 mm) | 101-631-02 |
| 2.00 inches (51 mm) | 101-631-03 |
| 2.25 inches (57 mm) | 101-631-04 |

