

# Off-load Grinders to Gaylords with Compressed Air

The CAML-EVG system uses a compressed air venturi to draw material from granulators or other sources and efficiently direct it to a standard gaylord box. The EVG's filling tube swivels on its mobile frame and is designed to be positioned between two gaylords, for rapid change-over when one gaylord becomes filled. A "full" alarm is included to alert operators.



## **CAML-EVG**

(Shown with the optional retractable cover and one gaylord.)

## Compact, Versatile Gaylord Filling Station

Conair's CAML-EVG provides two "parking spots" for gaylords to be filled by a clean, quiet compressed air system.

Controls are easily accessible on the moving fill tube arm and an optional, retractable, poly cover keeps off-loaded material clean.

The EVG can work continuously, on time settings (optional) or, when coupled with an optional demand sensor in the granulator drawer, the EVG will off-load the granulator only when regrind is present.

A standard CAML-EVG ships with 15 feet (4.5 m) of conveying hose.

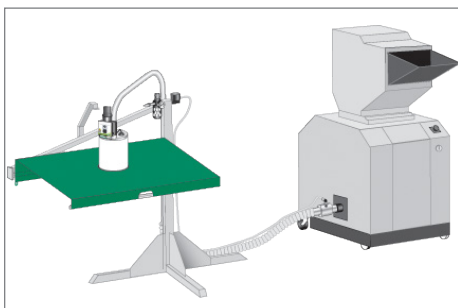

### ▶ **Keep granulators empty**

When connected to an optional granulator drawer demand sensor, granulators run free and clear of material back-up.

### ▶ **Change gaylords quickly**

The EVG's frame provides "parking-spots" for two gaylords so one may be moved while the other is filling. If only one is needed, the second spot is ideal for locating a mid-size granulator.

### ▶ **Flexible cover option**

Covers may be provided for one or two gaylords. They are pulled into place over gaylords in seconds - no tucking or stretching is necessary. Covers retract just as fast, rolling out of the way for maximum efficiency. Each cover includes a hole in the center for the filling tube of the EVG.

### ▶ **Built in overflow alarm**

The EVG lets you know when the gaylord is full so you can simply swing the filling tube over to the next gaylord and keep the material moving.

### ▶ **Clean, quiet, off-loading**

Adjust the compressed air supply as needed for distance and material flow. The EVG's filling arm includes a durable filter cloth for clean air exhaust.

# Specifications

Model	CAML-EVG
<b>Performance characteristics</b>	
Maximum throughput lb/hr {kg/hr}	700 {318}
Nominal throughput* lb/hr {kg/hr}	500 {227}
Maximum conveying distance ft {m}	20 {6}
Material line size inches {mm}	1.5 {38}
<b>Dimensions inches {mm}</b>	
A - Overall height	65.5 {1664}
B - Height, with optional casters	68.0 {1727}
C - Depth	45.0 {1143}
D - Width	48.0 {1219}
E - Width, add for each retractable cover	27.0 {686}
<b>Weight lbs {kg}</b>	
Shipping	185 {84}
Installed	160 {73}
Retractable cover weight, each	35 {16}
<b>Voltages Full load amps</b>	
120V/1 phase/60 Hz	1.5
<b>Compressed air requirements</b>	
Regulator set pressure psi {bars}	20-120 {1.4-8.3}
Consumption @ 60 psi ft <sup>3</sup> /min {liters/min}	8.25 {233.6}
Air inlet, NPT fitting	3/8 inch

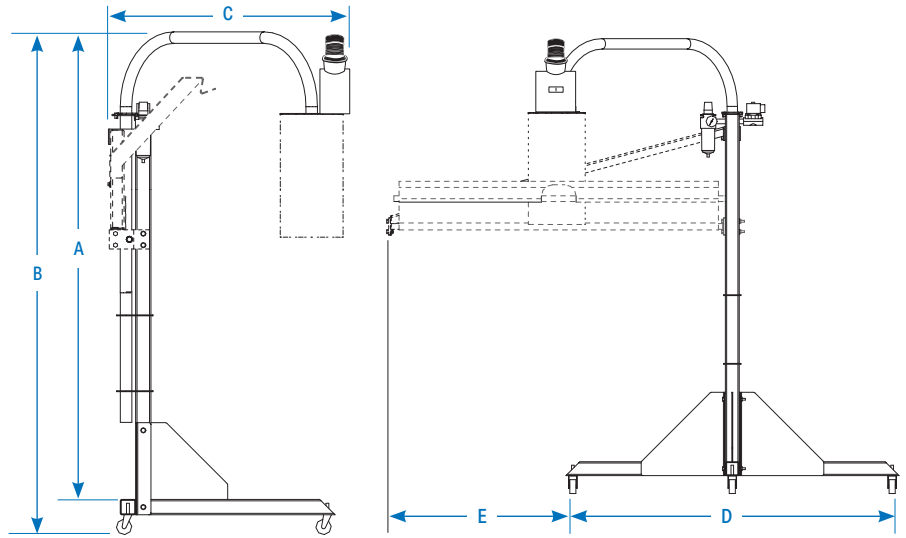

**Specification Notes**

\* Throughput is highly dependent upon material size, shape and flow rate. Performance claims are based on typical regrind. Large, small or poor flowing materials should be tested for suitability.

Specifications may change without notice. Consult with a Conair representative for the most current information.

# Options

## Material Pickup Devices

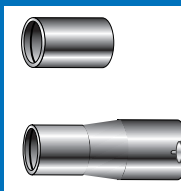

**O-ring adapters**  
Select the proper aluminum adaptor to connect the venturi to the granulator take-off tube.

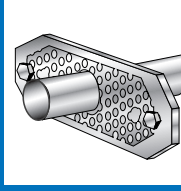

**Horizontal bin tube**  
Install the Material Transfer Device on granulator trays, bins or other flat-walled storage containers. High-wear Material Transfer Device is also available.

## Material Pickup Devices

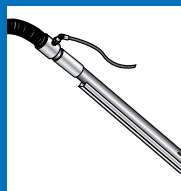

**Vertical feed tube**  
Inserts into open-top material containers. Couples to venturi.



**Granulator Bin Tube Adaptor**  
For air-tight granulator drawers, this adaptor provides an air inlet for optimal conveying. Adapts to round granulator drawer tubes (up to 2 inch OD).

## Retractable Gaylord Cover



Install one or two gaylord covers to minimize dust during the conveying operation and to prevent material contamination.

**Sensor Extension Cable**

When a demand sensor is used, this option provides 10 feet {3 m} of additional length.

**Casters**

Casters on the bottom provide simple mobility.