

Low-Noise, Vacuum Conveying Power

For moderate distance conveying applications, nothing beats the simplicity of a regenerative vacuum pump from Conair. Replacing larger, more complex positive displacement pump/motor units, RG Series Pumps utilize a one piece fan/motor unit to produce reliable vacuum power for loading systems up to 450 feet {137 m} and 7000 lbs/hr {3175 kg/hr}.

The simple, compact design allows the pump to be installed in nearly any indoor location, it can even be wall-mounted. Because the operating sound level is very low, concerns over noise pollution and proximity to personnel are minimal.



Model RG2-5

Single and Dual Stage Regenerative Pumps

Each pump is equipped with its own magnetic starter, ready to be connected to any loading control system. A vacuum pressure gauge and mechanical vacuum relief valve are also included.*

If short, frequent loading cycles are anticipated, the pump may be equipped with an optional idle mode valve that allows the pump to continue to run between loading cycles, eliminating nuisance start/stop cycles that can reduce pump life.

*Every vacuum conveying application should be assessed by Conair engineers to apply the appropriate equipment.

- ▶ **Requires no maintenance**
The pumps are permanently lubricated to reduce downtime.
- ▶ **Quiet operation**
Requires no soundproofing.
- ▶ **Reliable components**
RG Series Pumps include a vacuum relief valve, vacuum gauge, magnetic starter and overload protection.
- ▶ **Optional idle mode valve and timer**
This option eliminates frequent starting and stopping of the pump motor.
- ▶ **Optional filter canister**
The filter canister provides simplified dust collection for virgin material systems.

Typical Central Vacuum Conveying System using a RG Series Pump and Central Dust Collector

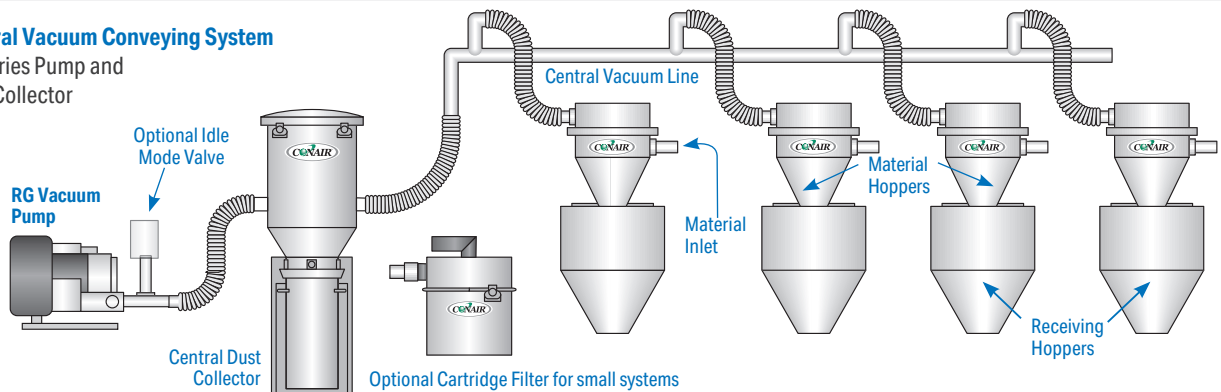

Specifications

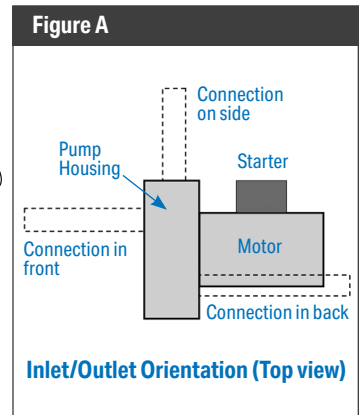
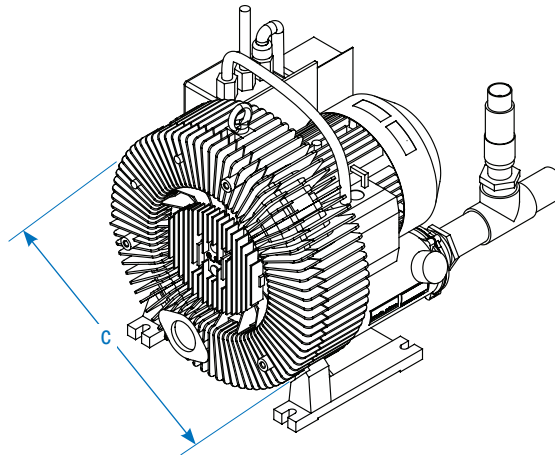
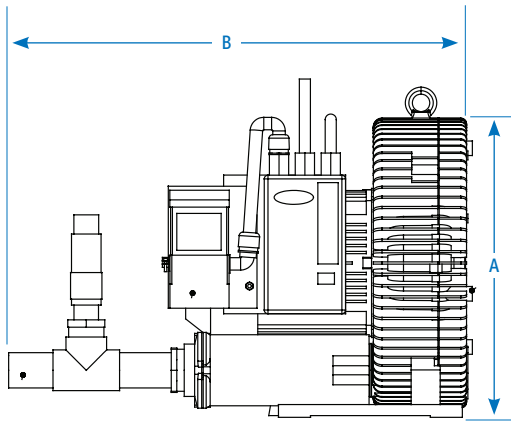

Model	RG1-3		RG1-6		RG1-11		RG2-5		RG2-8		RG2-16	
Single Stage or Dual Stage	Single		Single		Single		Dual		Dual		Dual	
Performance characteristics												
	60 Hz	50 Hz	60 Hz	50 Hz	60 Hz	50 Hz	60 Hz	50 Hz	60 Hz	50 Hz	60 Hz	50 Hz
Motor Hp*	3.4	N/A	6.2	5.4	11.5	10.1	5.1	4.4	8.45	7.4	16.9	14.8
Equivalent kW	{2.6}	N/A	{4.6}	{4.0}	{8.6}	{7.5}	{3.8}	{3.3}	{6.3}	{5.5}	{12.6}	{11.0}
Line size inches	1.5	N/A	2.0	1.5	2.5	2.0	1.5	1.5	2.0	1.5	2.5	2.0
Airflow at material pickup ft ³ /min	55	N/A	76	43	135	76	41	60	74	41	138	74
Airflow at pump inlet ft ³ /min	70	N/A	101	57	191	107	67	79	122	69	226	131
Pump Vacuum Inches Hg [†]	-6.2	N/A	-7.4	-7.4	-8.8	-8.4	-11.7	-7.3	-11.7	-12.2	-11.7	-12.9
Sound level (dba)	70	N/A	72	69	74	70	71	67	76	73	78	74
Inlet orientation (see Figure 1)	Back		Back		Back		Front		Back		Back	
Outlet orientation (see Figure 1)	Back		Back		Back		Back		Side		Back	
Motor type	TEFC											
Dust collector recommended	DC1	DC1	DC1	DC1	DC2	DC1	DC1	DC1	DC1	DC1	DC2	DC1
Dimensions inches (mm)												
A - Height	14 {355.6}		16 {406.4}		21 {533.4}		25 {635.0}		17 {431.8}		23 {584.2}	
B - Width	22 {558.8}		24 {609.6}		31 {787.4}		36 {914.4}		27 {685.8}		32 {812.8}	
C - Depth	15 {381.0}		18 {457.2}		21 {533.4}		18 {457.2}		28 {711.2}		28 {711.2}	
Weight lb {kg}												
Shipping	60 {27}		103 {47}		302 {137}		116 {53}		164 {74}		472 {214}	
Installed	55 {25}		93 {42}		282 {128}		106 {48}		154 {70}		452 {205}	
Voltage Full load amps (FLA) ‡												
230V (220-275)/3 phase/60 Hz	10.3	N/A	16.4	N/A	30	N/A	14.2	N/A	23	N/A	50.2	N/A
460V (380-480)/3 phase/60 Hz	6	N/A	9.5	N/A	17.3	N/A	8.2	N/A	13.3	N/A	29	N/A
400V (345-415)/3 phase/50 Hz	N/A	N/A	N/A	9.5	N/A	16.7	N/A	7.5	N/A	13.3	N/A	28
575V/3 phase/60 Hz	4.5	N/A	7.6	N/A	13.6	N/A	5.4	N/A	10.4	N/A	20.4	N/A

Specification Notes

* Hp rating is based on the kW rating of the blower. Not comparable to positive Hp ratings.

† Inches Hg: Inches of Mercury

N/A: Not Available

‡ FLA data for reference purposes only. Does not include any options or accessories on equipment. For full FLA detail for power circuit design of specific machines and systems, refer to the electrical diagrams of the equipment order and the nameplate applied to the machine.

Specifications may change without notice. Consult with a Conair representative for the most current information.

