

The Perfect Solution; The Right Price

Simple, reliable, good looks and the right price - everything you'd expect from a Conair dryer. The Conair SlimLine™ Series of Compressed Air Dryers offer a cost-effective drying solution for any low throughput applications and most resins.

The SlimLine is desiccant-free, moving parts are eliminated, energy consumption and maintenance costs are minimal.

This is the perfect solution for efficient drying at an affordable price.



Model SL15

Compact Design Installs to Machine Throat

These small-sized, light-weight dryers are easy to handle and can be conveniently mounted onto the throat of your processing machine, saving precious floor space.

SlimLine™ dryers use a continuous supply of clean, dehumidified compressed air at 100 psi {6.9 bar} to dry material. The standard dryer produces a dewpoint of 0°F {-18°C} which is sufficient for most drying applications. With the use of an optional membrane, process air can be generated with a dewpoint of -40°F {-40°C}.

Units are capable of delivering nominal throughput rates ranging from 0.25 {0.11} to more than 50 lb/hour {23 kg/hour}.

Operation of this dryer couldn't be easier: adjust the regulator, flip the switch to on, set the process temperature and you're drying.

▶ Easy to use

Installation is quick and easy. The on-board control is simple to learn – all functions are clearly identified right on the dryer label. You won't even have to think about this dryer once you start processing.

▶ No maintenance required

No moving parts, no filters to contend with on standard units, no desiccant. This dryer will deliver the reliable performance you need.

▶ Compact design

This slim, attractive dryer mounts easily to the throat of your machine. No need to buy or mount a separate hopper, the hopper for the SlimLine™ is incorporated into the sturdy, yet light-weight design.

▶ Saves you money

Energy efficient and low cost initial investment, the Conair SlimLine Series of Compressed Air Dryers are a fraction of the price of traditional dryers. Dryer start-up is intuitive.

How it Works

The SlimLine Compressed Air Dryer uses clean, dehumidified compressed air* supplied from your plant's compressed air system or a portable air compressor to produce hot, low dewpoint air that removes moisture from hygroscopic plastic materials.

*Compressed air must meet specification requirement of 100 psi (6.9 bar) and 40°F (4°C) dewpoint and a residual oil content of less than 3 mg/m³.

The Benefits

- **You'll save money.** The initial investment in a compressed air dryer costs far less than conventional dryers.
- **You won't have to deal with desiccant.** The use of desiccant has been eliminated.
- **You'll eliminate the hassle of up-keep maintenance.** No moving parts, no desiccant, no filter on standard units. This dryer ends the need for a lengthy list of standard maintenance procedures.

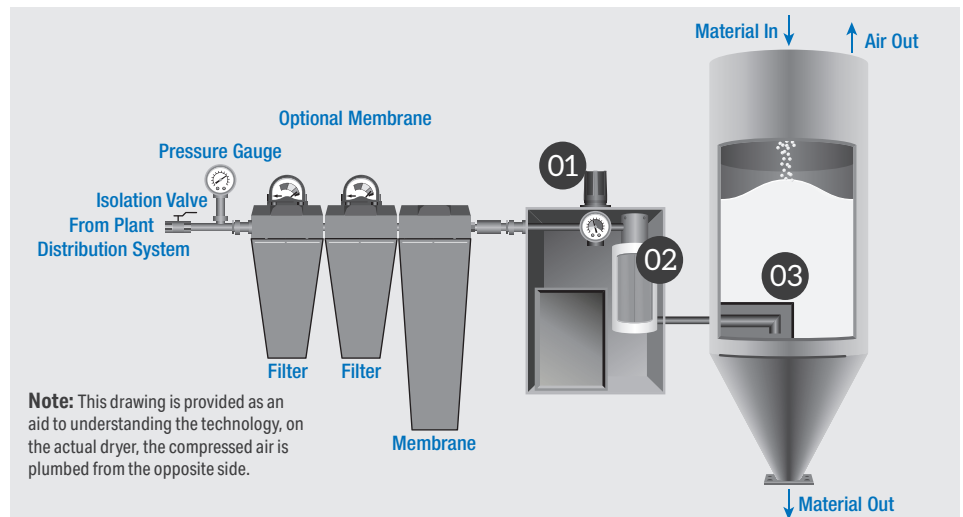

01

Clean, dry air is expanded to low pressure during the process of passing through the air regulator. Expanding the air reduces the dewpoint.

The regulator is also used to adjust the airflow to the green range on the pressure gauge.

02

Next, the air passes through an electric heater where it's temperature is raised to the process setpoint temperature.

03

Then, the air is injected into the hopper where it passes over the pellets and reduces the final moisture content of the plastic material to acceptable processing levels.

The air exhausts from the hopper into the atmosphere.

Options



Compressed Air Membrane

This option is necessary when the compressed air supplied does not meet the 40°F [4°C] dewpoint.

The membrane serves as a refrigerant air conditioner and reduces the dewpoint to the 40°F [4°C] dewpoint specification. The included filters aid in cleaning the compressed air.



TLA Adapter for Loader Fill

This adapter lets you mount a TLA Loader to fill the hopper, eliminating the need to hand fill the material.

Note: Adapter shown is for models SL2.5 and 5. This adapter is not required for models SL15 and 25. The TLA Loader will not be used with model SL50, other loaders are available.



Mobile cart

The mobile cart option allows the Slim-Line dryer and hopper combination to be quickly and easily moved from one location to another.



SL15 hopper has a hinged top plate. Hand-fill lid needed to cover center hole.



Hand-fill lid for models SL25 and SL50.

Hand-fill Lid

If you choose not to use a loader on Models SL15, SL25 or SL50, purchase the hand-fill lid to prevent material contamination.

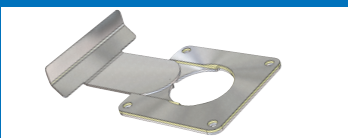

Slide Gate

Shuts off the material flow and isolates the dryer from the machine throat.

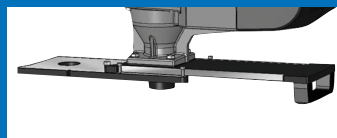

Mounting Adapter with Drain

Install the mounting adapter with drain to facilitate clean out or material changeovers.

Features

Simple, reliable control

You'll have all the functionality you need and not be burdened by an overly complicated control. Actual and setpoint drying temperatures are continuously displayed. Control functions are identified right on the label. Toggle between the percentage output of the heater (read only) and the high temperature alarm setpoint. Choose to view the temperature in fahrenheit or celsius.

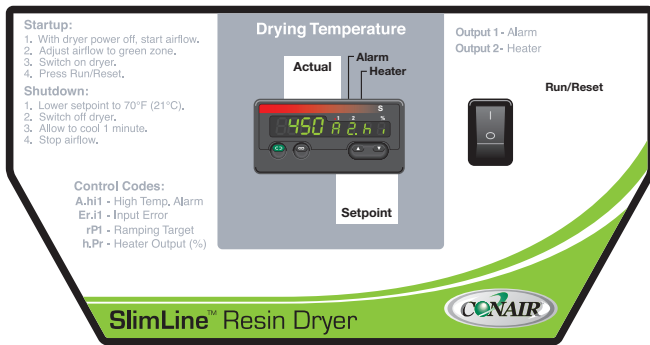

Loader fill or Hand-fill feature (model dependent)



Models SL2.5 and SL5 come standard with a hand-fill lid.



Models SL15, SL25 and SL50 come standard with an IB06 mounting interface for mounting a loader.

The loader is sold separately. This unit is pictured with an Access AL Series Loader installed.

A SlimLine™ to fit your application

The right technology for the right price, throughputs range from 0.25 {0.11} to 50 lb/hr {23 kg/hour}.



Specifications

Models SL2.5 and SL5

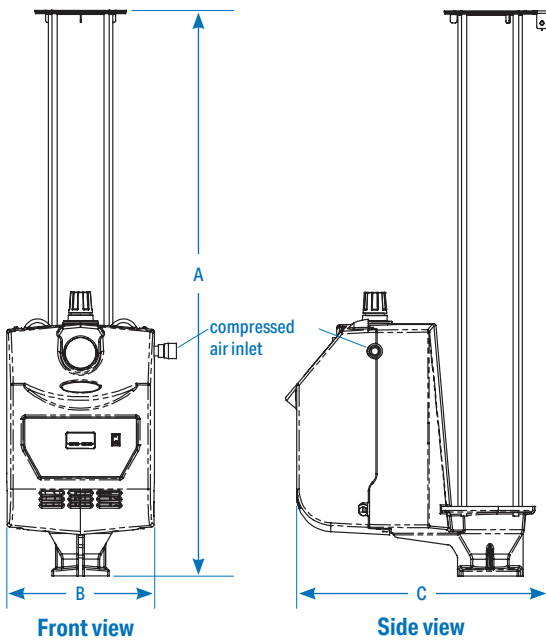

Models SL15*, SL25 and SL50

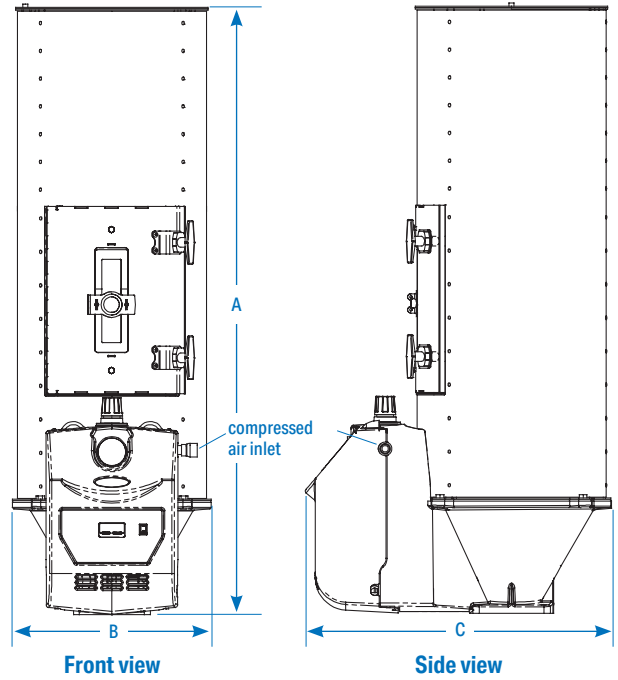

Models	SL2.5	SL5	SL15*	SL25	SL50
Performance characteristics (with full hopper)					
Drying temperature	100° - 350°F [38° - 177°C]				
Dewpoint	0°F [- 18°C] with optional membrane - 40°F [- 40°C]				
Airflow SCFM [SLM]	2.5 {71}	5.0 {142}	7.5 {212}	12.5 {354}	22.0 {623}
Airflow with membrane SCFM [SLM]	3.1 {88}	6.8 {193}	9.3 {263}	15.7 {445}	34.9 {988}
Hopper volume ft³ [L]	0.125 {4}	0.25 {7}	0.75 {21}	1.25 {35}	2.50 {71}
Heater size kW	1			2	
Dimensions inches [cm]					
A - Height	22.5 {57}	40.0 {102}	26.5 {67}	32.0 {81}	47.5 {121}
B - Overall width	11.0 {28}		12.5 {32}	15.5 {39}	
C - Depth	19.0 {48}		25.5 {65}	24.0 {61}	
Drying hopper inlet pipe size	1/2 inch NPT female				
Weight lbs [kg]					
Standard dryer installed (empty)	32 {15}	37 {17}	56 {25}	87 {39}	107 {49}
Shipping weight	60 {27}	70 {32}		160 {73}	
Voltage Full load amps †					
120 V/1phase/60 Hz	8.5		16.7		
220 V/1 phase/50 Hz	4.3		8.4		
Compressed air requirements †					
100 PSI {6.9 bar} clean, dry compressed air pressure dewpoint of 40°F {4°C}; residual oil content of less than 3 mg/m³					

Mounting Interfaces

Base Plate IB01

standard on models SL2.5, SL5 and SL15

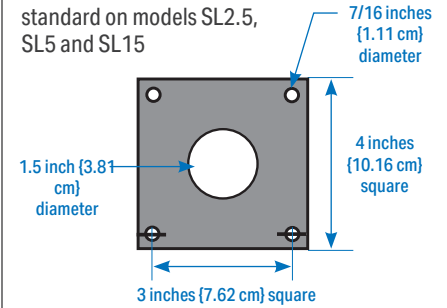

Base Plate IB02

standard on models SL25 and SL50

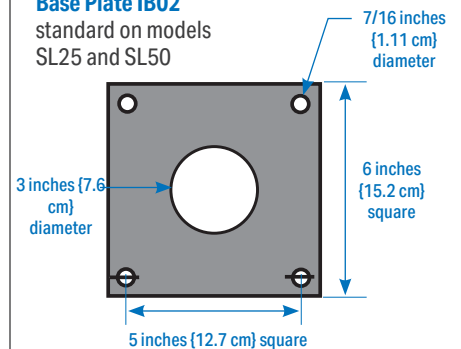

Application Notes

Conair recommends purchasing the optional membrane when:

Your process requires that you obtain a dewpoint of -40°F {40°C} or the compressed air dewpoint you are supplying is above 40°F {4°C}.

Specification Notes

SCFM - Standard Cubic Feet per Minute

SLM - Standard Liters per Minute

* Model SL15 does not include an access door on the hopper.

† Compressed air supplied to the dryer must meet specification requirement of 100 psi {6.9 bar} and 40°F {4°C} pressure dewpoint and a residual oil content of less than 3 mg/m³.

‡ FLA data for reference purposes only. Does not include any options or accessories on equipment. For full FLA detail for power circuit design of specific machines and systems, refer to the electrical diagrams of the equipment order and the nameplate applied to the machine.

Specifications can change without notice. Contact a Conair representative for the most current information.

