

Accurate, Precise Extrusion Control

TrueWeigh™ Gravimetric Control System allows extrusion processors to put their equipment on “cruise control.” It tracks material being fed to the extruder and automatically adjusts screw rpm and the haul-off device to maintain a consistent product output regardless of changes in raw materials, ambient conditions or processing variables.

The system offers functionality that suits both mono-layer and co-extrusion applications in film, sheet, extrusion coating, pipe, profile, tubing and wire & cable extrusion.



TWC Controller

Automates Extrusion Control by Weight

Varying process conditions, back-pressure, material bulk density, and even operator skill sets can reduce extruder throughput and affect productivity and profitability. This easy-to-use extrusion control system gives processors complete visibility and control over throughput and finished product dimensions.

TrueWeigh™ coordinates operation of up to twelve (12) extruders, governing not only total product throughput and dimensions, but also the relative weight of different layers.

Processors realize increased yield through precise, consistent control over extruder output and weight per length to maintain consistent rate and product thickness. Product quality can be improved with precise layer-ratio control in co-extruded film or sheet, and through better dimensional stability in tubing, pipe and profile wall thickness.

▶ Tightens tolerances, saves material costs

TrueWeigh™ allows processors to run products at minimum thicknesses (+/- 0.5% of set point). The extrusion control system synchronizes the extruder(s) and the haul-off device, optimizing stability of the production process and creating less start-up scrap by achieving production speeds quicker, and reducing or eliminating off-spec scrap.

▶ Easy-to-use, intuitive touch screen

7.0-inch LCD touch-screen controller with full color graphics allows quick and easy set-up. User-friendly screens are configurable to match each specific extrusion process type. Simple menu driven touch screens use a Q&A approach to guide the operator through set-up. The operator can monitor the extrusion control set points, the haul-off control data, current and past alarm status and complete management of material inventory data.

▶ Quality maintained during transitions

Advanced programming ramps extruder(s) and haul-off drives synchronously. This allows the system to make smooth transitions from one line output setting to a new target output while maintaining product quality.

Specifications

TrueWeigh Control Panel

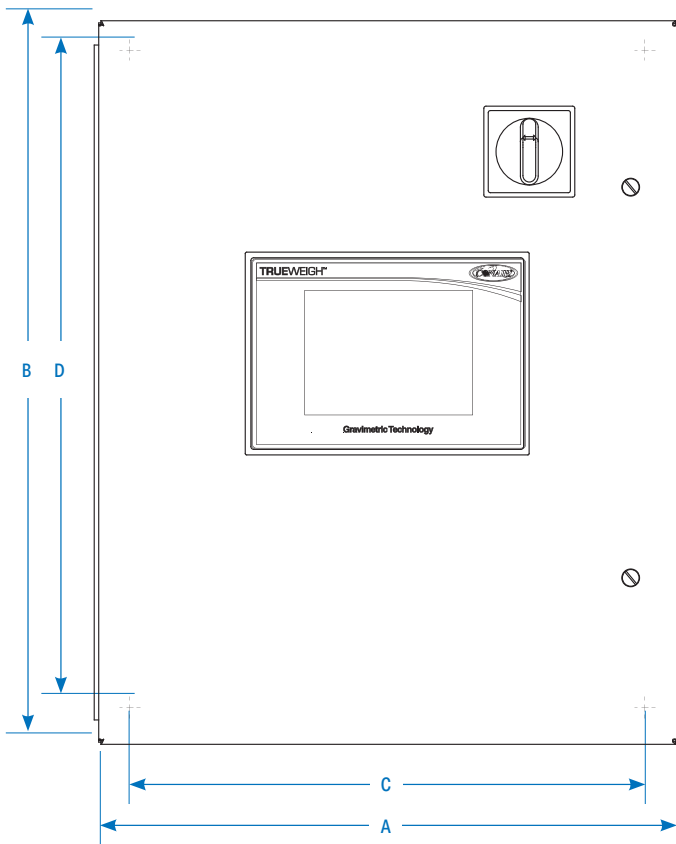

Remote Touch Screen

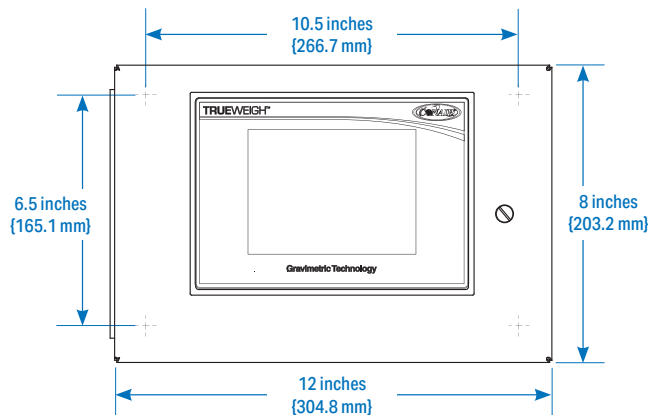

Model	TWC-1	TWC-3	TWC-5	TWC-7	TWC-9	TWC-12
Performance characteristics						
Maximum number of extruders	1	3	5	7	9	12
Dimensions inches {mm}						
A - Overall width	16 {406}	18 {457}	23 {584}		30 {762}	
B - Overall height	20 {508}	26 {660}	28 {711}	32 {813}	39 {991}	
C - Mounting width	14.5 {368}	16.5 {419}	21.5 {546}		28.5 {724}	
D - Mounting height	18.5 {470}	24.5 {622}	26.5 {673}	30.5 {775}	37.5 {953}	

Specification Notes

Specifications may change without notice. Please consult a Conair representative for the most current information.

Features

- 7.0-inch touch-screen HMI with PLC based controls
- Monitor one to twelve extruders and one haul-off
- Recipe book (stores 500 recipes and 250 resins)
- Trending, diagnostics, alarms and built-in help screens
- USB output to flash drive or printer
- Reports (inventory, alarm and status)
- Virtual Network Client (VNC) Viewer
- Selectable languages: English, Spanish, Portuguese, German, French, Russian, Chinese, Swedish and Korean

Options

- Extruder drive control
- Ramp drives simultaneously or independently
- Haul-off pulse encoder and drive control
- Remote mounted touch screen interface
- Audible/visual alarm
- Selectable remote communications protocols (OPC, Modbus TCP, Ethernet IP)
- Bumpless transfer
- SQL Data Output

