

# Downstream Extrusion Accessory Equipment

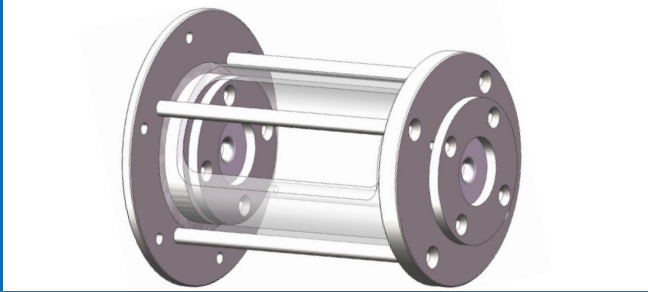

## Preskinner Assembly

- Calibrate/quench assembly for flexible materials
- Hold-down guide rollers, contoured or non-contoured
- Split-design air wipe assemblies
- Additional sets of pre-skinner inserts for other product sizes
- Flow meter rated for 7.5 to 75 gallons/hour (28.4-284 l/hr.) with pressure regulator

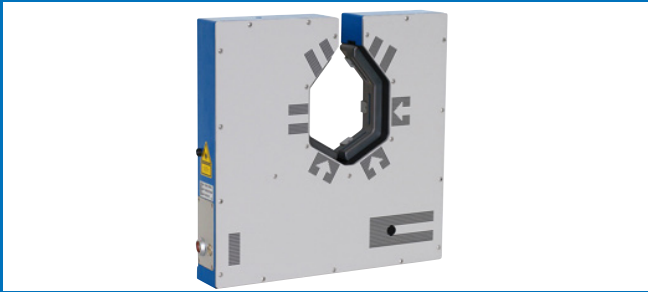

## Gauging interface

- Monitors the wall thickness
- Detects and measures ovality at any shape or angle
- Accurately measures diameter and circumference
- Helps as a fault detector
- A key accessory for precision tubing applications such as medical and automotive

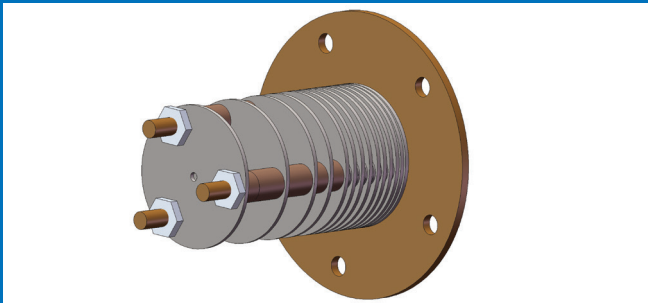

## Calibrators and Water Wells

- Helps maintain the size of the product to your specifications
- Sleeve-type, wafer, adjustable iris, or split design
- Split sizing plate for easy startup
- Sleeve-type, wafer, or split design
- Quick-change design
- FDA/Medical grade materials available

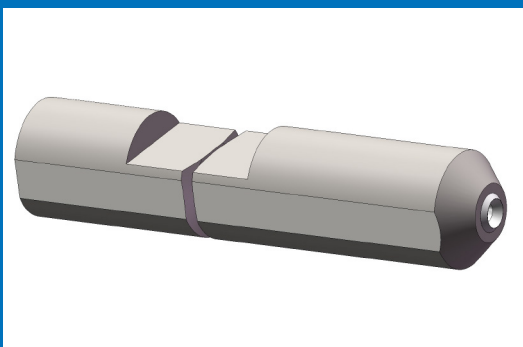

## Custom Cutter Bushings

- Made in a variety of materials, including for non-stick applications
- (316, 304 stainless, tool steel)
- Can be used with both Conair and other manufactured equipment
- Air feed and bolt-together, and lubed designs, along with traditional style bushing
- Quick-change design
- FDA/Medical grade materials available
- Can be used for corrugated product to cut accurate lengths
- Variety of sizes available

# Downstream Extrusion Accessory Equipment

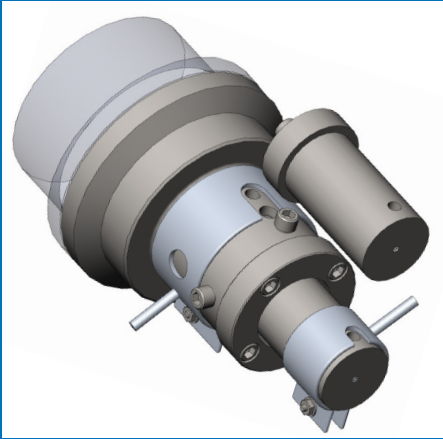

## Custom Tooling

- Quicker lead-time than all of our competition
- Lower costs
- Better quality
- Precision engineering and manufacturing
- Assembled and manufactured in the USA
- Custom designed to your specifications for your application
- Utilize Conair's lab facility to run trials of your production
- Tool steel or stainless steel available
- Heater band kits available
- Easy changeover from size to size. Four bolts remove quickly for disassembly to replace pin and bushing sizing tools.
- Variety of sizes to fit most extrusion applications
- Frosting units are available

## Running Lab Services

Conair has a running lab that can be used to run trials of your production. Customers and potential customers are welcome to travel to the lab and see the capabilities of the Conair equipment.

