

# Central Chilling With Large Capacity

Free up factory floor space with the Conair Water-Cooled W-SK Central Chillers. These large-capacity, heavy-duty chillers make the most of your energy dollars. Precise temperature control at the mold, die, screw or barrel results in faster cycle times and less warping and shrinking of the product.

Recirculating cooling water through a tower-chiller system also reduces water and sewer bills.

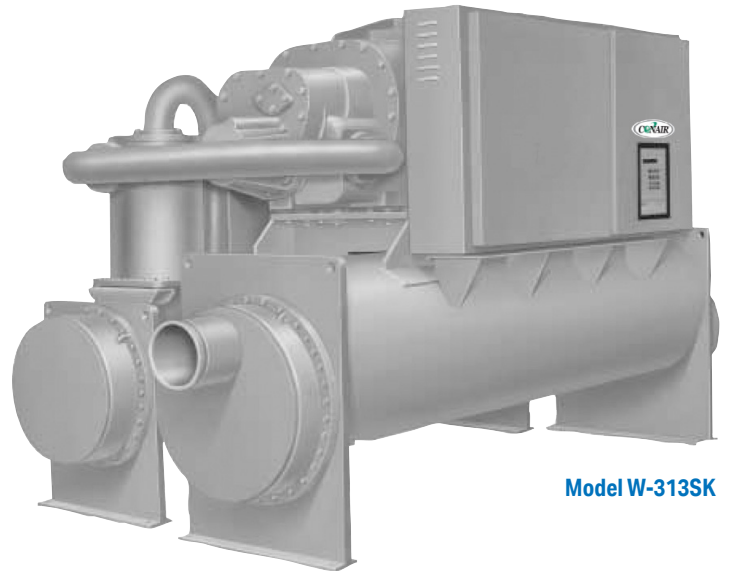

Model W-313SK

## Cooling Capacities from 210 Tons to 463 Tons

The Conair Water-Cooled W-SK Series Central Chillers are engineered for efficiency and reliability. The screw compressor is the most advanced compressor in the industry. The unit protects against starting and running overload, under and over voltages, phase loss, phase reversals, high winding temperature and rapid recycling.

The microprocessor control maintains chilled water temperature more accurately, resulting in less temperature drift.

The microprocessor monitors temperature and the rate of change over time, effectively controlling compressor loading for efficient chiller operation.

The screw compressor's positive displacement design results in lower energy costs.

### ► Rugged compressor design

The screw compressor has only four moving parts eliminating the need for pistons, connecting rods, wrist pins and valves. Fewer moving parts means less internal friction and greater efficiency.

### ► Customized to fit your needs

Conair has the central chiller to match your process. Pick nominal chilling capacities from 210 tons to 463 tons. Smaller capacities are available.

### ► Easy setup

Small unit size, factory wiring, easy lifting procedures and startup control logic result in quick and easy installation. And includes one day of startup services by a factory-trained technician.

### ► Trouble-free operation

Smart safety features and over 40 diagnostic displays for easy and virtually trouble-free operation.

## Features

- **Easy access controls**

Control has automatic compressor and condenser fan sequencing, load limiting, and anti-recycle functions.

- **Operator interface**

Monitors temperature and rate of change over time, effectively controlling compressor loading.

- **Tolerates slugging**

Compressors are designed to handle liquid slugging.

- **Low flow switch**

Field installed to positively detect flow loss of evaporator solution.

- **Water regulating valves**

for condenser water lower than 85°F {29.4°C}.

- **Helical rotary compressor**

Compressor has only four moving parts; direct-drive, low speed for high efficiency and high reliability.

- **Evaporator**

Shell-and-tube evaporator uses seamless internally finned copper tubes, roller-expanded into tube sheets.

- **Energy efficient**

Results in lower energy costs when compared with reciprocating compressor designs.

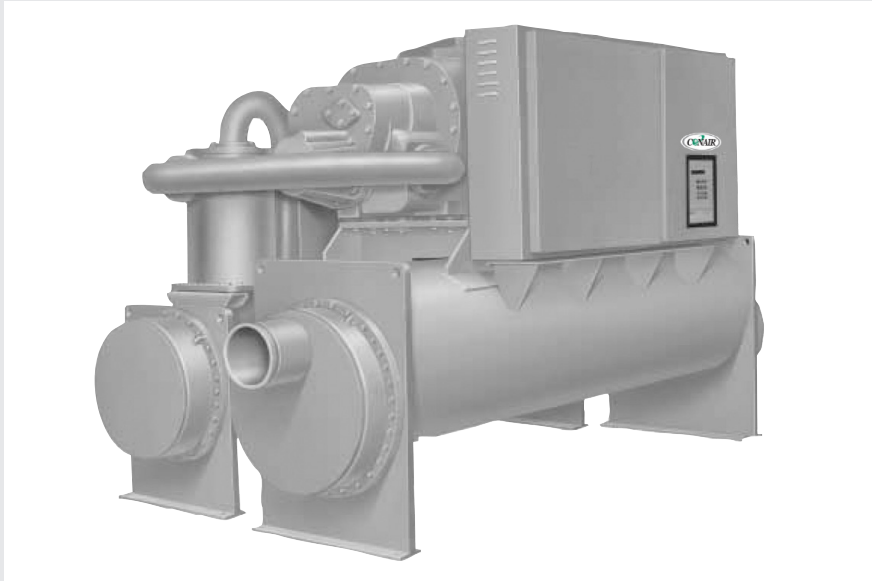

## Control

01

### File Tabs

Advanced interface allowing the user to access set-points, active temperatures, modes, electrical data, pressures and diagnostics.

### LCD Touch Screen with LED Backlight

02

Easy-to-read screen provides system information.



### Microprocessor Control with Human Interface Panel (HMI)

- Designed to take corrective action to prevent unit shutdown.
- Limit compressor operation with smart safety controls, avoiding compressor or evaporator failures.
- Built-in chiller flow protection automatically detects no-water flow condition.
- Improved chiller start-up, load limiting, compressor anti-recycle timing, and lead/lag functions.
- Alarm diagnostic displays specific information for quick action.
- Service menu offers easy troubleshooting by controlling all outputs individually.
- Chiller capacity algorithm optimizes setpoint control and provides evaporator freeze protection.
- Failure protections include loss of chilled solution flow, chiller freeze protection, chilled solution flow interlock, head pressure control, pump down control, and low ambient lockout.

## Helical Rotary Screw Compressor

- **Only four moving parts** when compared to reciprocating compressors; there are no pistons, connecting rods, suction and discharge valves or mechanical oil pump.
- **Reduced rotor tip clearance** results in reduced leakage between the high and low pressure cavities during compression.
- **Latest heat transfer technology** results in increased condenser and evaporator tube efficiency.
- **Resistant to liquid slugging** with a compressor design that can handle amounts of liquid refrigerant that would severely damage a reciprocating compressor.
- **Helical screw design** results in part load performance far superior to single reciprocating compressors.

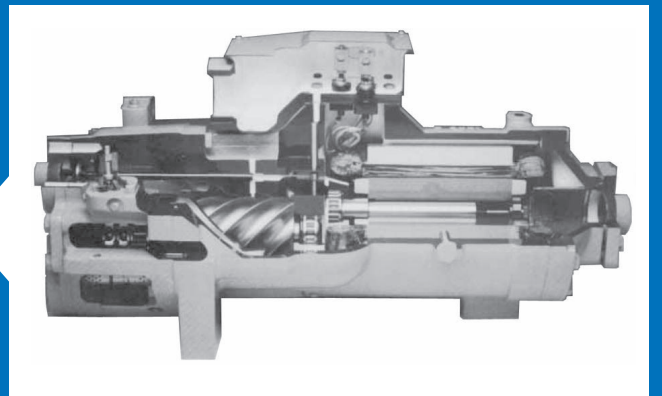

Cutaway of the screw compressor

## Options

- **Different LWT Ranges**  
Standard leaving water temperature ranges from 37° to 65°F {2.8° to 18.3°C} and optional temperature ranges from 10° to 65°F {-12.2° to 18.3°C}.
- **Remote Setpoint**  
Input for integration into the control system.  
Choose 4-20 mA or 2-10 vDC.
- **Percent Full Load**  
Output indicating percent of chiller nominal RLA. Choose 4-20 mA or 2-10 vDC.
- **Programmable Relays**  
Factory installed relays for dry contact indication of chiller status with choice of relay assignments from a list of possible assignments.
- **Disconnect**  
External handle allows local power shutoff to control center.
- **Solid State Starter**  
Hybrid SCR/Contactor to extend starter life on units that will be starting frequently.
- **Smooth Bore Tubes**  
Smooth wall 0.035 inch {0.889 mm} tubes in condenser for high fouling water applications.
- **Compressor Warranty**  
Choose an additional two- to five-year compressor component replacement warranty.

## Specifications

### Specification Notes (see following pages)

- \* Based on entering condenser water temperature of 85°F {29.4°C}, leaving condenser water temperature of 95°F {35°C}, leaving chilled water temperature as shown and 10°F {5.56°C} water temperature drop through the evaporator. Capacity ratings are (+/-) 5% and are subject to change without notice.
  - † Leaving water temperature setpoints lower than 45°F {4.4°C} may require 3-pass evaporator or special tube construction in order to operate properly. Consult factory for pricing. Capacities shown have been selected with water.
  - ‡ Chilled water flow is based on nominal capacity at 50°F {10°C} leaving water temperature and 10°F {5.6°C} water temperature drop through the evaporator.
  - § Differential pressure (drop) is for listed nominal design flow of 100% water.
  - \*\* Tower water flow is based on nominal capacity with 85°F {29.4°C} entering water temperature and 10°F {5.6°C} water temperature drop through the evaporator.
  - †† GRV: Grooved pipe connections.
  - †† MCA: Minimum circuit ampacity. MOP: Maximum overcurrent protection. Rated voltage usage range: 200/3/60 (180-220), 230/3/60 (208-254), 400/3/50 (364-440), 460/3/60 (414-506), 575/3/60 (516-633). Standard starter will be Across-the-Line. Solid state available as an added price option.
- Specifications may change without notice. Check with a Conair representative for the most current information.

# Specifications

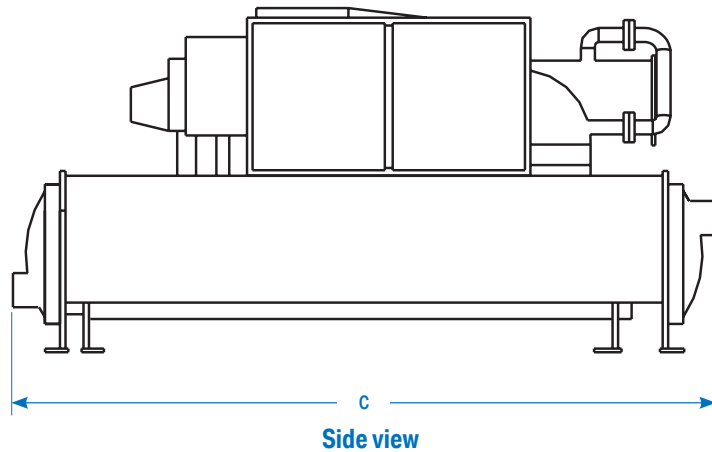
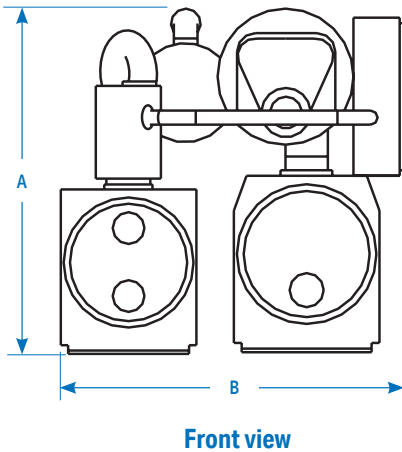

Model	W-210SK	W-227SK	W-313SK	W-363SK	W-427SK	W-463SK						
<b>Capacity* at 85°F [29°C] condenser water inlet tons [kcal]</b>												
40°F [4.4°C] †	168.5 [509,536]	182.1 [550,661]	252.0 [762,035]	292.9 [885,715]	346.5 [1,047,799]	376.8 [1,139,424]						
45°F [7.2°C]	188.7 [570,619]	203.9 [616,583]	281.6 [851,544]	327.1 [989,134]	385.6 [1,166,035]	418.6 [1,265,825]						
50°F [10.0°C]	209.9 [634,727]	226.8 [685,832]	312.7 [945,589]	363.1 [1,097,996]	426.8 [1,290,622]	462.6 [1,398,879]						
55°F [12.8°C]	232.4 [702,766]	251.2 [759,616]	345.8 [1,045,682]	401.1 [1,212,906]	470.1 [1,421,559]	508.9 [1,538,888]						
60°F [15.5°C]	256.2 [774,736]	277.1 [837,936]	380.8 [1,151,520]	441.2 [1,334,167]	515.8 [1,559,753]	557.6 [1,686,154]						
<b>Performance characteristics</b>												
Chilled water flow gpm [lpm] †	502.0 [1900]	542.4 [2053]	747.9 [2831]	868.3 [3287]	1020.6 [3863]	1106.3 [4188]						
Evaporator pressure drop psi [bar] §	2.8 [0.19]	2.5 [0.17]	2.4 [0.16]	1.7 [0.12]	2.7 [0.19]	2.8 [0.19]						
Tower water flow gpm [lpm] **	590.3 [2235]	637.3 [2412]	873.4 [3306]	1009.2 [3820]	1195.5 [4525]	1295.0 [4902]						
Condenser pressure drop psi [bar] §	7.1 [0.49]		5.2 [0.36]	6.7 [0.46]	10.4 [0.72]	10.5 [0.73]						
<b>Dimensions, weights, amps (chiller only) inches [mm]</b>												
A - Height	74.40 [1890]		76.20 [1935]		76.10 [1933]							
B - Width	64.90 [1648]		67.90 [1725]		68.20 [1732]							
C - Length	125.40 [3185]		143.00 [3632]		145.50 [3696]							
Evaporator connections ††	8.00 [203]			10.00 [254]								
Condenser connections ††	6.00 [152]			8.00 [203]								
<b>Weight lb [kg]</b>												
Shipping	9292 [4215]	9402 [4265]	14,718 [6676]	16,168 [7334]	16,187 [7342]	16,820 [7629]						
Installed	9867 [4476]	10,019 [4545]	15,818 [7175]	17,560 [7965]	17,537 [7955]	18,220 [8264]						
<b>Utility requirements ††</b>												
<b>Power consumption amps</b>	<b>MCA</b>	<b>MOP</b>	<b>MCA</b>	<b>MOP</b>	<b>MCA</b>	<b>MOP</b>	<b>MCA</b>	<b>MOP</b>	<b>MCA</b>	<b>MOP</b>	<b>MCA</b>	<b>MOP</b>
200V/3 phase/60hz	490	800	525	800	697	1200	N/A					
230V/3 phase/60hz	426	700	457	800	606	1000	700	1200	N/A			
460V/3 phase/60hz	213	350	229	400	303	500	350	600	414	700	447	800
575V/3 phase/60hz	170	300	183	300	242	400	280	500	331	500	358	600
<b>Performance characteristics @ 50 Hz electrical service</b>												
<b>Capacity* at 95°F [35°C] ambient and leaving water temperature tons [kcal]</b>												
50°F [10°C]	174.0 [526,167]	190.7 [576,667]	257.4 [778,365]	309.0 [934,400]	353.6 [1,069,269]	385.4 [1,165,430]						
Chilled water flow gpm [lpm] †	416.0 [1575]	456.0 [1726]	615.5 [2330]	738.9 [2797]	845.5 [3201]	921.6 [3489]						
Evaporator pressure drop psi [bar] §	1.9 [0.13]	1.8 [0.12]	1.6 [0.11]	1.2 [0.08]	1.9 [0.13]							
Tower water flow gpm [lpm] **	486.0 [1840]	532.4 [2015]	714.7 [2705]	853.1 [3229]	982.4 [3719]	1070.3 [4052]						
Condenser pressure drop psi [bar] §	5.0 [0.35]	5.1 [0.35]	3.6 [0.25]	4.9 [0.34]	7.3 [0.50]	7.4 [0.51]						
Power consumption, amps ††	MCA	MOP	MCA	MOP	MCA	MOP	MCA	MOP	MCA	MOP	MCA	MOP
400V/3 phase/50hz	199	350	215	350	228	450	333	500	394	700	414	700

Specification Notes (see previous page)

