

Efficient Cooling with Minimum Maintenance

Conair's E4 series induced draft, counterflow cooling towers offer more cooling, but require less space and less maintenance.

From the rust-proof molded polyethylene tower shell to the corrosion-resistant direct drive fan assembly, E4 towers contain fewer components that could fail and hamper performance.

All water connections, the water distribution system and the cellular fill are made of PVC to resist rot, decay and biological attack.



Model E4-310

(with optional top platform with hand rails)

Less Water and Sewer Usage; Save Money

Conair cooling towers recirculate process cooling water, paying for themselves in reduced water costs and sewer taxes.

A fixed PVC water distribution system sprays hot water over high-efficiency angled-baffle PVC cellular fill. The spiral fill design extends the water's travel path and exposure to air, increasing the heat transfer area for efficient cooling.

The fans draw air through inlet louver panels at the base, and then upward through the fill. Heat is removed when water on the multiple surfaces of the fill evaporates.

Options include: variable frequency drives on the fan motor to closely control temperature and save energy; an aluminum access ladder with safety cage.

▶ Easy inlet/outlet connections

Single-point inlet water connection. Choose the optional side outlet with make-up float valve, or the standard bottom outlet for use with remote tanks and sumps.

▶ Seamless, rust-free design

Our one-piece MDPE tower shell will not rust, corrode, chip, crack or require protective coating or painting. There are no seams, panels or rivets to fail or compromise performance. All fasteners are 304 stainless steel.

▶ Costs less to install

The lightweight design reduces rigging and structural roof support requirements. Everything, including the tower mounted base structure, is factory assembled for easy installation. Just lift the tower into place and hook up water and electricity.

▶ 20-year warranty

We're so confident our molded polyethylene shell will not rust, chip or crack, we back it with a 20-year warranty. We also warrant the totally enclosed, direct drive fan motor for five years and provide a one-year parts and labor warranty on the entire tower.

Specifications

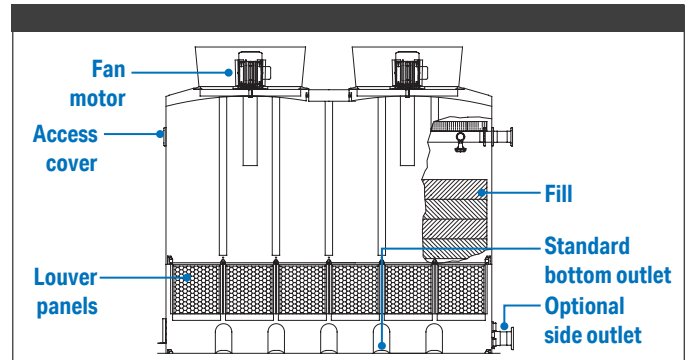
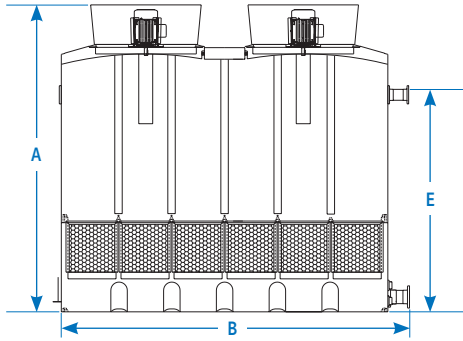

Models E4-310 to E4-428

Models E4-604 to E4-836

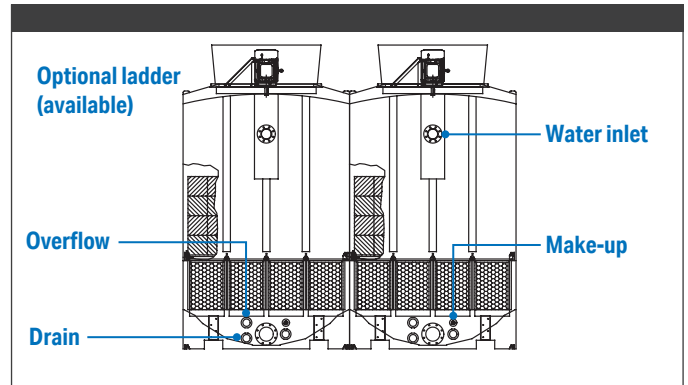
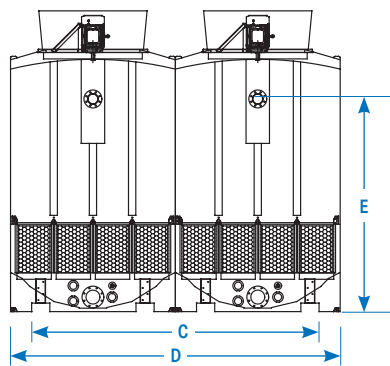
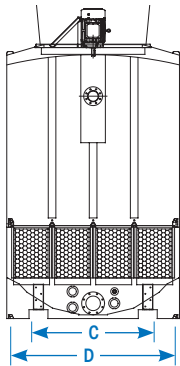

Installation Notes

For best performance, the tower must be installed in a location free from obstructions that may restrict airflow through the intake louvers or induce recirculation of discharge air. All external piping must be independently supported. The fan ring, where air is discharged, should be level with or higher than the wall or roof line.

Model	E4-310	E4-346	E4-377	E4-428	E4-604	E4-681	E4-738	E4-836*
Performance characteristics								
Tower capacity tons [†]	310	346	377	428	604	681	738	836
Sump capacity gallons (liters)	480 {1817}				960 {3596}			
Fan motor number x Hp (kW)	2 x 5 {3.73}	2 x 7.5 {5.59}	2 x 10 {7.45}	2 x 15 {11.2}	4 x 5 {3.7}	4 x 7.5 {5.6}	4 x 10 {7.5}	4 x 15 {11.2}
Dimensions inches (cm)								
A - Total height				186.0 {472}				
B - Total length				208.0 {528}				
C - Mounting base length	64.56 {164}				2 x 64.56 {164}			
D - Total width	102.0 {259}				204.0 {518}			
E - Height to inlet				131.5 {334}				
Height to center of overflow				16.0 {41}				
Height to center of drain				5.25 {13}				
Height to center of make-up	28.0 {71}				16.0 {41}			
Approximate weight lb (kg)								
Shipping (dry)	6400 {2903}	6500 {2948}	6600 {2994}	6700 {3039}	13000 {5897}	13100 {5942}	13200 {5988}	13300 {6033}
Operating with side outlet	12100 {5489}	12200 {5534}	12300 {5579}	12400 {5625}	24400 {11068}	24500 {11113}	24600 {11159}	24700 {11204}
Operating with remote sump/tank	8350 {3788}	8450 {3833}	8550 {3878}	8650 {3924}	16900 {7666}	17000 {7711}	17100 {7757}	17200 {7802}
Voltage full load amps[§]								
208v/3 phase/60 Hz	33.2	48.7	70.8	97.3	66.3	97.3	141.5	194.6
230v/3 phase/60 Hz	30.0	44.0	64.0	88.0	60.0	88.0	128.0	176.0
400v/3 phase/50 Hz	17.3	25.3	36.8	50.6	34.5	50.6	73.6	101.2
460v/3 phase/60 Hz	15.0	22.0	32.0	44.0	30.0	44.0	64.0	88.0
575v/3 phase/60 Hz	15.0	22.0	32.0	44.0	30.0	44.0	64.0	88.0
Connections inches								
Water inlet / outlet - Flanged	6.0 / 8.0				2 x 6.0 / 2 x 8.0			
Make-up water - NPT	1.0				2 x 1.0			
Overflow and drain - NPT	4.0				2 x 4.0			
Water requirements[†]								
Inlet pressure psi (bars)				4.0 - 5.5 {0.28 - 0.38}				
Max. inlet temperature °F (°C)				140 {60}				

Specification Notes

* Larger and other sizes of towers in this series are available, consult factory.

† Based on 95°F {35°C} inlet water, 85°F {29°C} outlet water, and 78°F {26°C} entering wet bulb temperature and 3.0 gpm/ton of water flow. Consult factory for other conditions. 1 tower ton = 15,000 Btu/hr.

‡ Due to the unique design of the E4 Series Cooling Towers, customer specifications must include design flow requirements.

§ FLA data for reference purposes only. Does not include any options or accessories on equipment. For full FLA detail for power circuit design of specific machines and systems, refer to the electrical diagrams of the equipment order and the nameplate applied to the machine.

Specifications may change without notice. Consult with a Conair representative for the most current information.

