

## High-Efficiency, Budget-Friendly Cooling

Conair's E1F Series Cooling Towers are lightweight fiberglass towers designed for corrosion resistance, low maintenance, and efficient operation at a competitive price.

These towers are carefully engineered and manufactured with the optimum combination of heat transfer media, uniform air flow, and even water distribution to minimize operating costs.

Conair's E1F Series induced draft, counterflow towers are rust-proof, not just rust-protected.



**Model E1F-060**  
(with optional ladder)

## Rugged, Consistent, Efficient Operation

Conair cooling towers pay for themselves by recirculating process cooling water, which saves water costs and sewer taxes.

Hot water enters at the top and is sprayed over a continuous coil of angle-baffle PVC decking. Air flowing upward from the base removes the heat through evaporation. The spiral decking design extends the water's travel path and exposure to air, increasing the heat transfer area for efficient cooling.

All water connections, the water distribution system and the wet decking are made of PVC to eliminate corrosion and resist rot, decay and biological attack.

The adjustable pitch cast aluminum fan blades allow for energy-efficient operation.

Options include: basin heater, fan thermostat, mechanical float make-up valve, vibration switch, structural steel mounting base and mounting legs.

### ▶ Rust-free design

Fiberglass tower casing, basin and air inlet louvers have a smooth exterior gel-coat with UV inhibitors. Galvanized steel supports and stainless steel fasteners prevent rust.

### ▶ Costs less to install

The main casing and basin ship fully-assembled. To prevent shipping damage, the fan motor, fan blade and sprinkler head assembly ship uninstalled requiring only minor field assembly to complete tower installation.

### ▶ Simple inlet/outlet connections

The E1F features single-point inlet water connections. Choose the optional side outlet with make-up float valve, or the standard bottom outlet for use with remote tanks and sumps. Drain and overflow connections are included.

### ▶ Application specific options

Conair has a variety of options for your specific application. A structural steel base and legs can be purchased for quick installation. A mechanical float make-up valve maintains water level for optimum performance. A basin heater is ideal for colder locations. An equalization connection for connecting several tower basins equalizes basin water levels by letting cooled water flow between basins. A stainless steel sprinkler head is available.

### ▶ 10-year shell warranty

We warrant the fiberglass shell and basin against material defects and workmanship for ten years. The remainder of the tower has a one year parts warranty.



## Features

### 01

Durable fiberglass shell resists corrosion and harsh weather conditions.

### 02

Convenient sight glass for inspection of internal features or for maintenance.

### 03

Optional ladder for easy access to the motor and fan.

### 04

Detachable fiberglass inlet louvers making it easy to clean and inspect the basin.

### 05

Totally enclosed fan motor.

### 06

Direct-drive cast aluminum or polypropylene fan, angled for optimal air movement.

### 07

Self-rotating, nonferrous water distribution system with no-clog openings.

### 08

PVC fill media maximizing air/water contact which optimizes heat transfer.



## Specifications

Model	E1F-038	E1F-060	E1F-080	E1F-100	E1F-120
<b>Performance characteristics</b>					
Tower capacity tons*	38	60	80	100	120
Sump capacity gallons (liters)	105 {397}	162 {613}	183 {693}	190 {719}	198 {750}
Blower motor Hp (kW)	2.0 {1.49}		3.0 {2.24}		5.0 {3.73}
<b>Dimensions inches (mm)</b>					
A - Total height	84 {2134}	92 {2337}	109 {2769}		115 {2921}
Diameter	75 {1905}	84 {2134}	95 {2413}		
<b>Approximate weight lb (kg)</b>					
Shipping (dry)	600 {272}	750 {340}	1250 {567}	1300 {590}	1400 {635}
Operating	1475 {669}	2100 {953}	2780 {1261}	2890 {1311}	3050 {1383}
<b>Voltage full load amps †</b>					
230v/3 phase/60 Hz	8.0	10.0	12.0		16.0
460v/3 phase/60 Hz	4.0	5.0	6.0		8.0
<b>Connections NPT inches</b>					
Water inlet / outlet	3.0	4.0	5.0		
Drain	2.0				
Make-up water	0.75		1.0		
Overflow	1.0				
<b>Water requirements</b>					
Minimum inlet pressure psi (bar)	3.0 {0.20}		5.0 {0.34}		
Maximum flow rate gpm (l/min)	200 {750}	340 {1285}	500 {1890}		
Maximum inlet temperature °F (°C)	110 {43}				

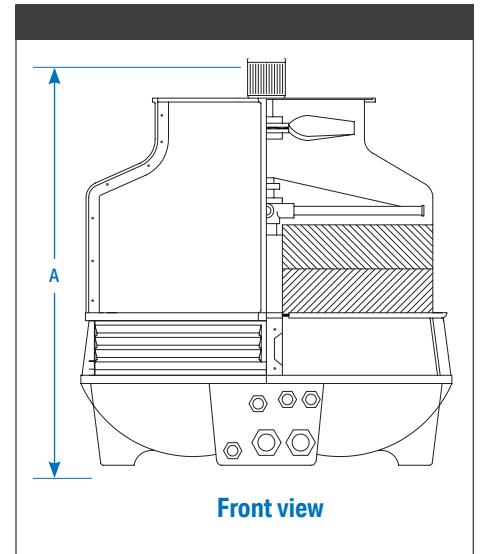

Front view

### Specification Notes

\* Cooling tower tons are based on 15,000 BTU/Hr/ton with 95°F {35°C} entering water temperature, 85°F {29°C} leaving water, 78°F {26°C} ambient wet bulb temperature and 3.0 gpm/ton water flow except note below.

† Maximum gpm for tower.

‡ FLA data for reference purposes only. Does not include any options or accessories on equipment. For full FLA detail for power circuit design of specific machines and systems, refer to the electrical diagrams of the equipment order and the nameplate applied to the machine.

Specifications may change without notice. Consult with a Conair representative for the most current information.

