

Rust-Free Operation For Years of Reliable Service

Conair's PTFG (fiberglass) Series Pump Tanks are designed to meet and exceed the needs of your application. Fully engineered for a complete range of tower or chiller applications, Conair's tanks provide the highest quality design and construction features available.

This series of pump tanks promises years of trouble-free operation with the use of high quality components.



Model PTFG-0500

To Eliminate Corrosion Issues – Choose Fiberglass

Conair incorporates more value-added features into every pump/reservoir system than anyone else. Every PTFG tank includes standard, full-size pump trim, extended pump suction legs and solid steel decking under the pump.

High-efficiency, close-coupled, non-overloading centrifugal pumps are precisely matched to your application, providing optimum flow and pressure to the process with reduced electrical costs, and improving motor life by assuring the motor operates within its horsepower rating.

Conair's full-sized pump suction legs feature a 45° angle opening to prevent vortexing and pump cavitation. This also enables the tank to operate at a lower water level, saving water costs and reducing the use of valuable chemicals that may otherwise over-flow to drain at shutdown.

▶ **Quality construction, safe operation and easy maintenance**

All pumps are mounted on a solid deck for added strength, serviceability, and safety. Reservoirs are constructed of thick fibre-reinforced plastic (FRP) for superior strength and reliability. Horizontal stiffeners are used for extra strength. Interiors are coated with a smooth white gelcoat lining.

▶ **Economic alternative to stainless steel**

The PTFG Series fiberglass reservoirs offer a significantly less expensive alternative to stainless steel reservoirs in applications where corrosion can be problematic.

▶ **Easy to operate**

The Conair programmable controller comes with digital temperature display and a RTD probe that controls temperature by cycling the tower fan and recirculating pump. The control includes a high temperature alarm with indicator light. Liquid-filled pressure gauges enable accurate flow adjustment. Isolation cocks prevent gauge pressure fluctuation and extend gauge life.

▶ **Quick installation**

By using the grooved pipe connecting system, the need for flexible couplings is reduced, eliminating pipe stress at start-up. Grooved connections quickly assemble and disassemble for fast installation, maintenance, and reconfiguration when adding or changing pumps. Conair's prewired and mounted control panel is hardwired to pump motors and all alarms, simplifying field installation and significantly reducing installation costs.

Reservoir Features

01

Fiberglass tank divider

02

Make-up valve assembly guarantees constant water level



Control Panel



All Conair PTFG Series control panels come completely prewired and use only high quality components.

Options

- Single or dual standby pumps for process and recirculating eliminate downtime. Pumps are available with complete connecting trim, including discharge manifold and isolation valves.
- Automatic switching to standby pump protects against downtime due to pump failure.
- Full 0.75 inch {19mm} insulation maintains reservoir water temperature and eliminates "sweating".
- Premium efficiency motors cut electrical operating costs and offer rapid payback with utility rebate programs.
- Unbreakable sight glass features shutoff valves and brass safety rods; allows for a quick visual check of reservoir operating level.
- Tank cover prevents contamination and evaporation.
- Factory-installed and wired alarms with panel mounted indicator lights warn of low flow, low pressure, low level and high temperatures. Sonalert horn with silencer switch warns of system failure.
- Solid-state sensor with alarm provides trouble-free sensing of low water levels.
- For operator protection, a fused disconnect shuts off power before door is opened for maintenance or inspection.
- Panel-installed programmable logic controller (PLC) allows control sequences and alarm settings to be customized for individual process requirements.
- Reservoir support legs conserve valuable floor space, support a cooling tower to reduce roof loading and eliminate additional roof support costs.

Pump Curves

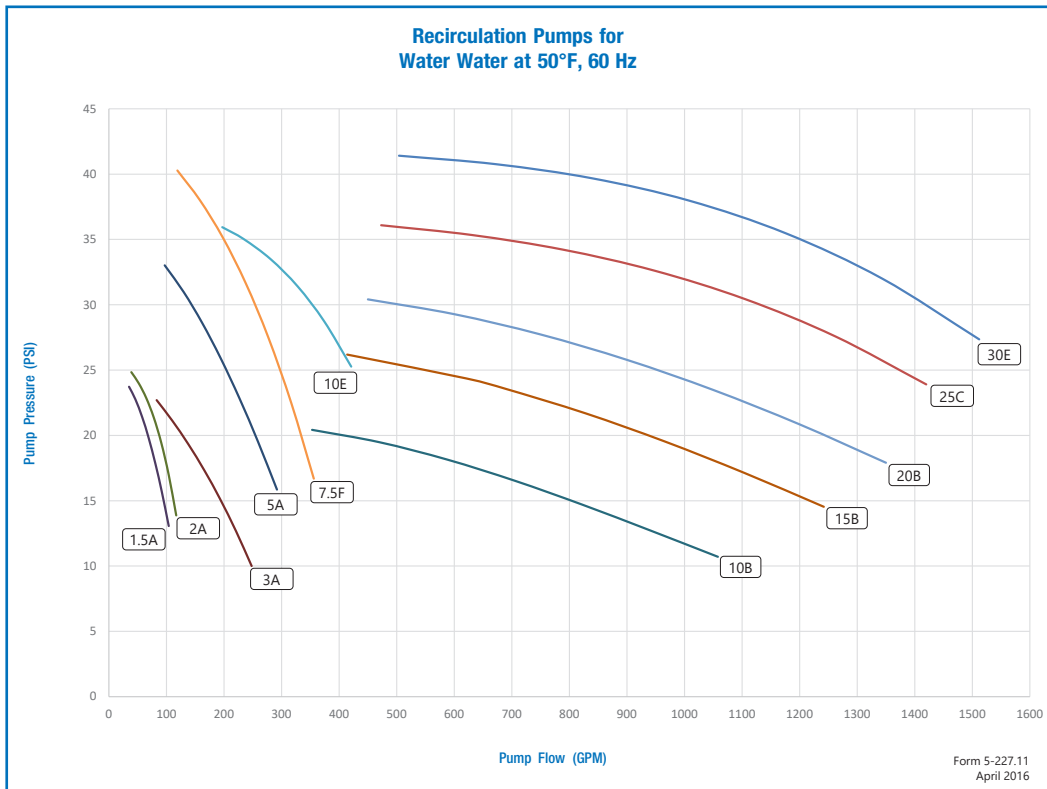
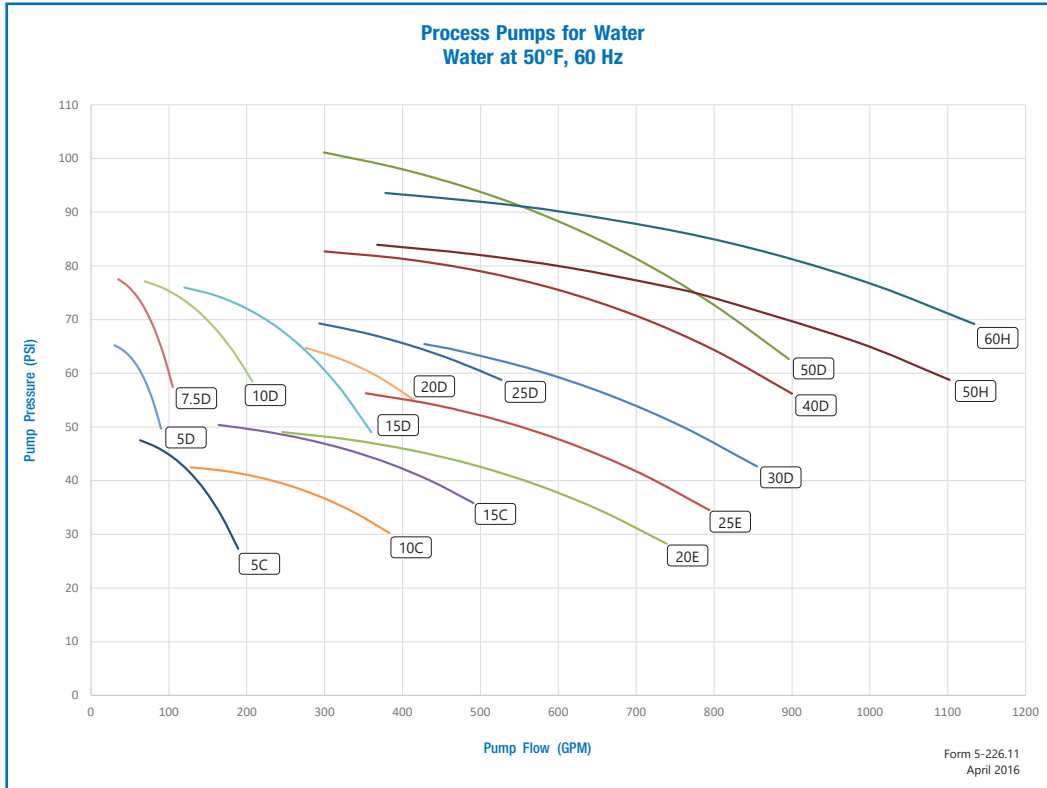

Specification Notes

- Pump curves do not reflect pressure drops due to internal piping.
- These pump curves are non-overloading using the service factor of the motors.
- Specifications may change without notice. Check with a Conair representative for the most current information.



Specifications

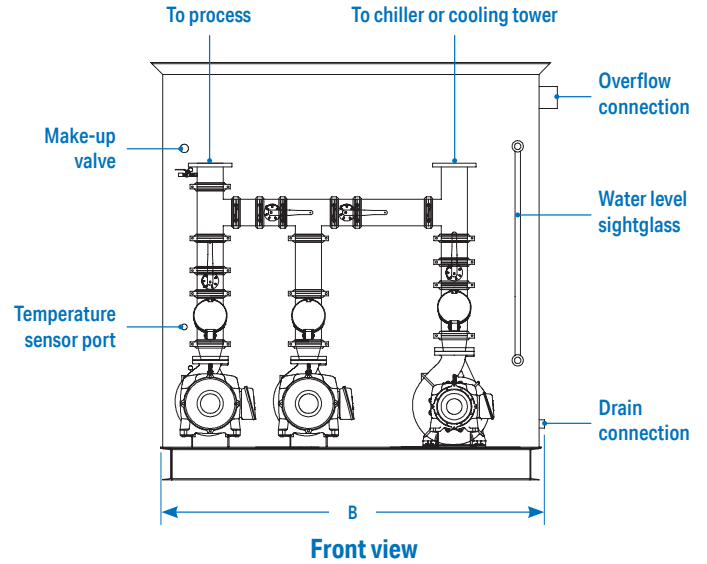
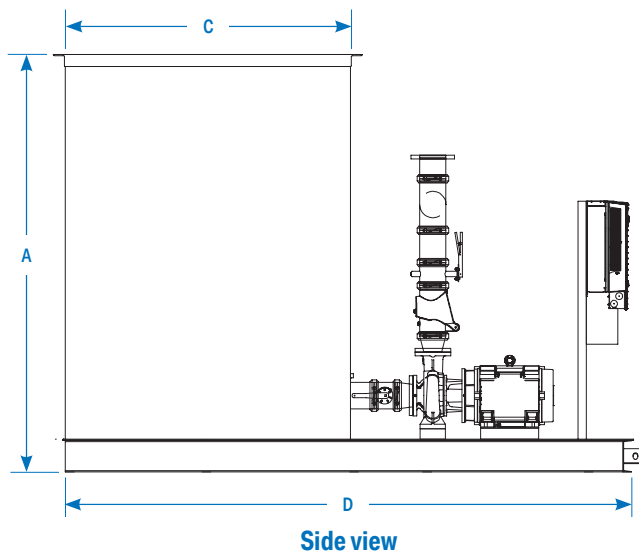

(Electrical control panel and variable frequency drives not shown in this view for clarity.)

Models	PTFG-0250	PTFG-0500	PTFG-0700	PTFG-1100	PTFG-1550	PTFG-2200
Performance characteristics gallon {liter} [*]						
Capacity to overflow	275 {1041}	470 {1779}	705 {2669}	1105 {4183}	1615 {6113}	2200 {8328}
Operating capacity	160 {606}	335 {1268}	480 {1817}	710 {2688}	1165 {4410}	1600 {6057}
Operating chiller	200 {757}	355 {1344}	540 {2044}	850 {3218}	1345 {5091}	1790 {6776}
Dimensions inch {mm} [†]						
A - Height	52 {1321}	55 {1397}		84 {2133}		86 {2184}
B - Width	70 {1778}	57 {1448}	81 {2057}	74 {1880}	81 {2057}	98 {2489}
C - Tank length	33 {838}	57 {1448}		59 {1498}	82 {2083}	84 {2134}
D - Total length	62 {1575}	98 {2489}		122 {3099}	146 {3708}	
Connections NPT inch						
Overflow				4.0		
Make-up				1.0		
Drain	1.0					2.0
Weight lb {kg} [†]						
Shipping	2000 {907}	2500 {1134}	3000 {1361}	3500 {1588}	4000 {1814}	4500 {2041}
Operating	4200 {2041}	6400 {2903}	9000 {4082}	14,200 {6441}	17,300 {7847}	24,100 {10,932}

Specification Notes

- * Operating level based upon allowing for 30 ft {9144 mm} of vertical riser drain down and for tower systems the typical cooling tower drain down.
- † Dimensions and weights shown are for a typical 3-pump arrangement. Actual weights and dimensions will vary depending on pump and option selections. Specifications may change without notice. Consult with a Conair representative for the most current information.

