

Water and Energy Efficient Adiabatic Cooling

Adiabatic cooling systems are ideal for processors with concerns about their water supply and process water purity, where conventional tower systems could put their process at risk. The EarthSmart™ Adiabatic Tower (ESTW Series) design provides efficient, easily managed heat control with less need for maintenance than other systems. All this is accomplished with smart motor technology and a simple fluid flow through the system to bring temperatures down to the right level.



Model ESTW-26

Resource-Efficient, Reliable Cooling

EarthSmart Adiabatic Towers cool process fluids at an industrial scale while minimizing the amount of energy and water that is consumed.

Utilizing adiabatic wetted panels, mounted outside of the cooling tower coil, process fluids move efficiently through the tower coils without ever being exposed to ambient air, contamination, or even evaporation. Conair units can cool up to 510 gallons per minute* while potentially saving millions of gallons of water per year.

Options are available for epoxy coating, to protect machines in coastal areas, and motor repair switches, to allow fans to be serviced without stopping the process.

* Nominal flow rate of 35% Ethylene Glycol (35% EG) fluid mixture by weight.

▶ **Closed loop purity, minimal water consumption**

The EarthSmart™ Towers circulate process fluid inside the tubes of the cooler coils isolating it from ambient contamination. This fluid is cooled by circulating ambient air across the coils. As air passes through the wetted pads, water is evaporated and the air inside the unit is lowered to provide process fluid cooling.

▶ **Strong, resilient coil design**

Coils are supported independently of the frame, allowing for natural expansion and contraction which eliminates wear points and extends the lifespan of the coil.

▶ **Smart fan technology; smooth and quiet operation**

One piece fan and motor units provide powerful cooling performance and energy savings. Variable fan speed is automatically controlled to minimize energy use. Motor repair switches allow fans to be individually serviced without stopping the process.

▶ **Long-life, easily serviced cooling panels**

Internal air temperature is cooled with a carefully moderated supply of water, while process fluids remain safely within the coils of the tower module. EarthSmart wetted media panels slide out easily for cleaning with no special tools required.

▶ **Intelligent Water Saving Adaptive Controls**

Our new controls add industry best water conservation levels. Our sophisticated controls precisely calculate the minimum amount of water needed to cool the incoming warm air based on the dry air temperature, the wet bulb temperature, and the actual process load. A modulating valve precisely controls water use for peak performance.

How it works

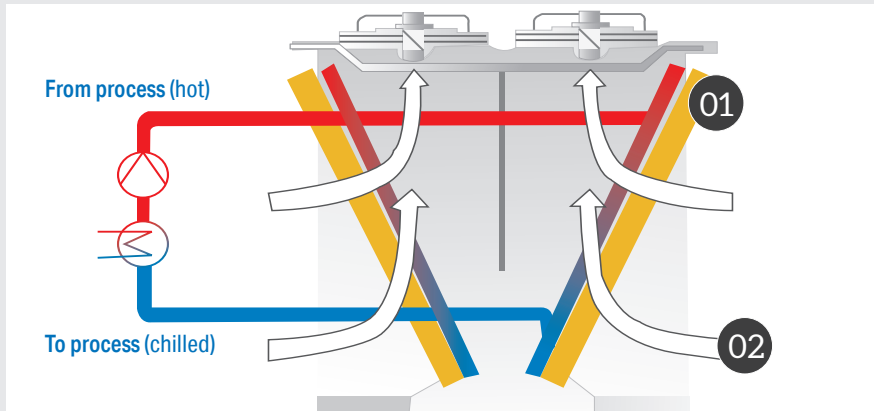

01

Adiabatic pads are kept cool by an independent water supply which never mixes with your process, to prevent contamination.

02

Air flow is managed by the cool adiabatic pads, keeping the unit's interior refrigerated, while the fans keep air moving out of the machine as it warms.

The adiabatic design **saves water and energy** by keeping the process fluid separate from the water evaporated during the adiabatic process. By only utilizing the adiabatic process when it is absolutely required during higher outdoor air temperatures, the unit minimizes water consumption to fractions of traditional systems.

The reduction in compressor energy usage permits higher coefficients of performance, with a significantly reduced energy footprint and cost to the operator.

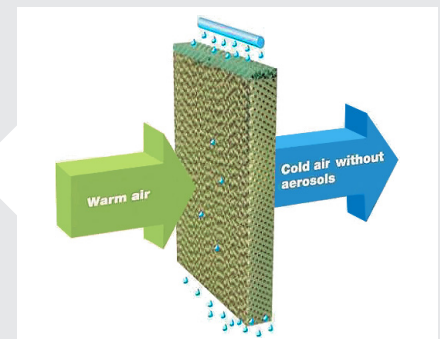

Options

Motor repair switches

Provides a non-fused fan motor safety-switch for each fan of a single row unit (ESTW-12 through ESTW-14) or one for each pair of fans on a dual-row unit (ESTW-22 through ESTW-29). Inside the fluid cooler each fan of a single-row unit or each pair of fans on a double-row unit are separated with an air deflector plate to allow a fan motor to be serviced without stopping the unit.



Epoxy coated fins

An epoxy coating is applied to the fins to protect them from damage in coastal installations where the aluminum fins on standard units are prone to corrosion from the presence of salt in the air. This option is recommended if the fluid cooler is installed within five miles of a coastal area. The epoxy coating has a slight insulating effect and the ability of the fins to dissipate heat is slightly diminished with approximately a 7% reduction in the overall capacity of the unit.

Specifications

Model ESTW-29 - Front view

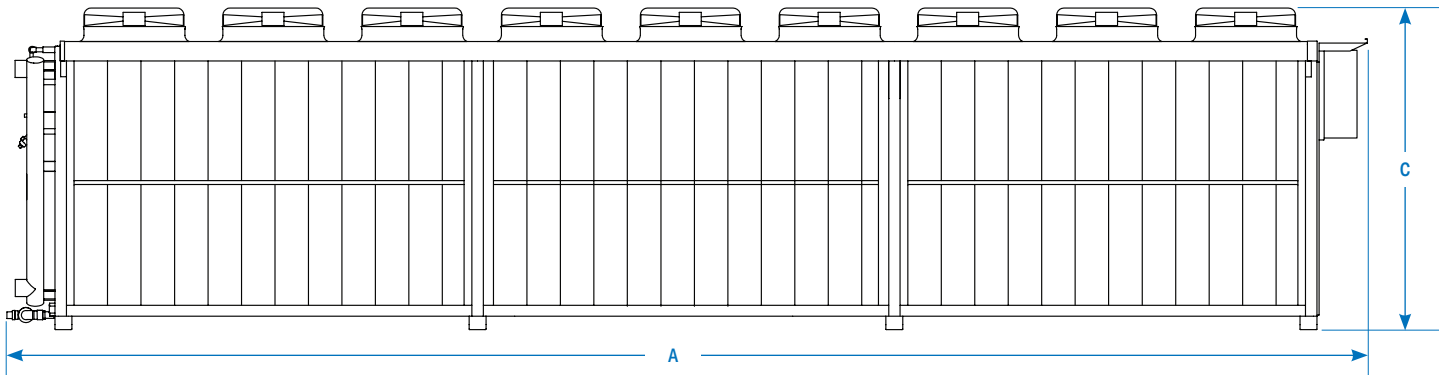

Model	ESTW-12	ESTW-13	ESTW-14
Performance characteristics			
Nominal flow rate* gpm	45	70	105
Nominal† tons	17	26	40
Coil design entering air temperature‡ °F [°C]	80.3 [26.8]		
Fluid pressure drop PSI	5.3	7.6	9.8
Approximate internal water volume gallons (l)	15 {57}	22 {83}	30 {114}
Adiabatic full flow rate gpm	6.2	9.4	12.5
Noise level§ dBA	55 dB (A)	57 dB (A)	58 dB (A)
Dimensions inches (mm)			
A - Length	102 {2591}	149 {3785}	196 {4979}
B - Width	47 {1194}		
C - Height	68 {1724}		
Number of legs	6	8	10
Approximate weight lb {kg}			
Shipping (dry)	1100 {499}	1600 {726}	2075 {941}
Operating	1225 {556}	1783 {809}	2325 {1055}
Electrical characteristics**			
Fans (quantity) Hp {kW}	(2) 3 {2.2}	(3) 3 {2.2}	(4) 3 {2.2}
200/3/60 MCA / MOP	17.4 / 30	25.1 / 35	32.8 / 45
230/3/60 MCA / MOP	17.4 / 30	25.1 / 35	32.8 / 45
400/3/50 MCA / MOP	8.4 / 15	12.1 / 20	15.8 / 20
460/3/60 MCA / MOP	8.4 / 15	12.1 / 20	15.8 / 20
Connections inches (mm)			
Inlet & outlet connection (quantity)	(2) 1.37 {35}	(2) 1.56 {41}	(2) 2.12 {54}
Adiabatic water inlet size	1 {25}		

Model ESTW-29, side view

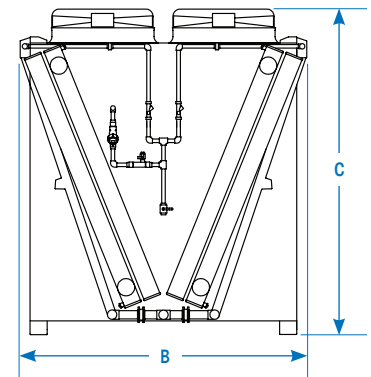

Specification Notes

* Nominal flow rate of 35% Ethylene Glycol (35% EG) fluid mixture by weight.

† Nominal Tons is heat rejection based on 35% EG cooling fluid at Nominal Unit Flow Rate entering the unit at 95°F and leaving at 85°F with 95°F DB/77°F WB ambient design conditions. Tons = 12,000 BTUH.

‡ Coil Design Entering Air Temperature is the Dry Bulb (DB) temperature entering the coil after the adiabatic effect at 95°F DB/77°F WB ambient design conditions. This would be the ambient DB temperature at which adiabatic water usage is required to produce the leaving water temperature at design full load.

§ Noise Level dBA weighted at 32.8 ft.

** MCA is Minimum Circuit Ampacity / MOP is Maximum Overcurrent Protection.

Specifications may change without notice. Consult with a Conair representative for the most current information.

Specifications

Model	ESTW-22	ESTW-23	ESTW-24	ESTW-25	ESTW-26	ESTW-27	ESTW-28	ESTW-29
Performance characteristics								
Nominal flow rate* gpm	107	165	210	280	290	333	400	510
Nominal† tons	41	63	81	107	111	128	153	195
Coil design entering air temperature‡ °F [°C]	80.3 {26.8}							
Fluid pressure drop PSI	4.3	5.4	4.0	7.2	9.2	2.3	3.6	6.9
Approximate internal water volume gallons {l}	50 {1270}	75 {1905}	100 {2540}	125 {3175}	150 {3810}	165 {4191}	190 {4826}	205 {5207}
Adiabatic full flow rate gpm	6.2	9.4	12.5	15.6	18.7	21.8	24.9	28.0
Noise level§ dBA	58	60		61	62		63	64
Dimensions inches {mm}								
A - Length	114 {2896}	163 {4141}	213 {5411}	263 {6681}	313 {7951}	363 {9221}	412 {10,465}	462 {11,745}
B - Width	95 {2413}							
C - Height	113 {2871}							
Number of legs	4		6	8		10	8	
Approximate weight lb {kg}								
Shipping (dry)	3350 {1520}	4650 {2109}	6250 {2835}	7760 {3520}	8375 {3799}	10400 {4717}	12160 {5516}	13225 {5999}
Operating	3767 {1709}	5276 {2393}	7084 {3213}	8803 {3993}	9626 {4366}	11776 {5342}	13745 {6235}	14935 {6774}
Electrical characteristics**								
Fans (quantity) Hp {kW}	(4) 3 {2.2}	(6) 3 {2.2}	(8) 3 {2.2}	(10) 3 {2.2}	(12) 3 {2.2}	(14) 3 {2.2}	(16) 3 {2.2}	(18) 3 {2.2}
200/3/60 MCA / MOP	32.8 / 45	48.3 / 60	63.6 / 80	79.0 / 90	94.4 / 110	109.8 / 125	125.2 / 140	140.5 / 175
230/3/60 MCA / MOP	32.8 / 45	48.3 / 60	63.6 / 80	79.0 / 90	94.4 / 110	109.8 / 125	125.2 / 140	140.5 / 175
400/3/50 MCA / MOP	15.8 / 20	23.2 / 30	30.6 / 35	38.0 / 45	45.34 / 50	52.8 / 60	60.2 / 70	67.6 / 80
460/3/60 MCA / MOP	15.8 / 20	23.2 / 30	30.6 / 35	38.0 / 45	45.34 / 50	52.8 / 60	60.2 / 70	67.6 / 80
Connections inches {mm}								
Inlet & outlet connection (quantity)	(2) 2.12 {54}	(2) 2.62 {67}	(2) 3.12 {79}	(2) 3.62 {92}		(2) 4.12 {105}	(2) 4.12 {105}	
Adiabatic water inlet size	1 {25}		1.5 {38}					

Specification Notes

* Nominal flow rate of 35% Ethylene Glycol (35% EG) fluid mixture by weight.

† Nominal Tons is heat rejection based on 35% EG cooling fluid at Nominal Unit Flow Rate entering the unit at 95°F and leaving at 85°F with 95°F DB/77°F WB ambient design conditions. Tons = 12,000 BTUH.

‡ Coil Design Entering Air Temperature is the Dry Bulb (DB) temperature entering the coil after the adiabatic effect at 95°F DB/77°F WB ambient design conditions. This would be the ambient DB temperature at which adiabatic water usage is required to produce the leaving water temperature at design full load.

§ Noise Level dBA weighted at 32.8 ft.

** MCA is Minimum Circuit Ampacity / MOP is Maximum Overcurrent Protection.

Specifications may change without notice. Consult with a Conair representative for the most current information.

