

# Safely Directs Materials to Conveyor Feed Tubes

Conair Tilters provide a safe method of moving free-flowing materials to one corner of a shipping container for complete emptying by a vacuum loader. These newest tilters include a built-in safety ratchet, which does not allow tilt-back of the tilter until the operator desires. This prevents the possibility of pinch points under the gaylord and tilter. Conair Tilters are built tough to withstand heavy use on production floors.

The tilters can be used beside your processing machines or in remote central material storage rooms to assure a constant flow of material throughout your plant. Once emptied, simple foot- or hand-operated controls level the container for removal and replacement.



120 Series Raised Platform Tilter

## Floor Level Or Raised Platform Models

Gaylord tilters are available for safely holding containers weighing up to 3,000 lbs.

Floor level tilters are either hand or foot operated and can hold containers up to 2500 lb. They can be set for either manual or automatic operation and include a safety ratchet that keeps operators safe.

It can be easily loaded by a hand truck or pallet mover because the box platform is flat on the floor. A heavy-duty air bag device slowly fills with compressed air to automatically tilt the platform and container as it is emptied. An adjustable conveyor feed tube support is included.

Raised platform tilters are operated by heavy-duty air cylinders. This type of tilter is adjusted so that it will start lifting the container when less than 500 lbs remain in the box. Then it slowly tips the box to a 45° angle to assure smooth continuous feeding to the vacuum feed tube.

- ▶ **Wide capacity range**  
Capacities for 1200 lb, 1500 lb, 2500 lb and 3000 lb loads.
- ▶ **Prevent material voids**  
Air or electric-operated vibrators are available to prevent material voids.
- ▶ **No electricity required**  
Compressed air operated.
- ▶ **Automatic or manual operation**  
Tilters can be set for either manual or automatic operation. The tilters will automatically swing up as material is emptied to assure a constant flow of material.



299 Series Floor Level Tilter

# Specifications

# Options

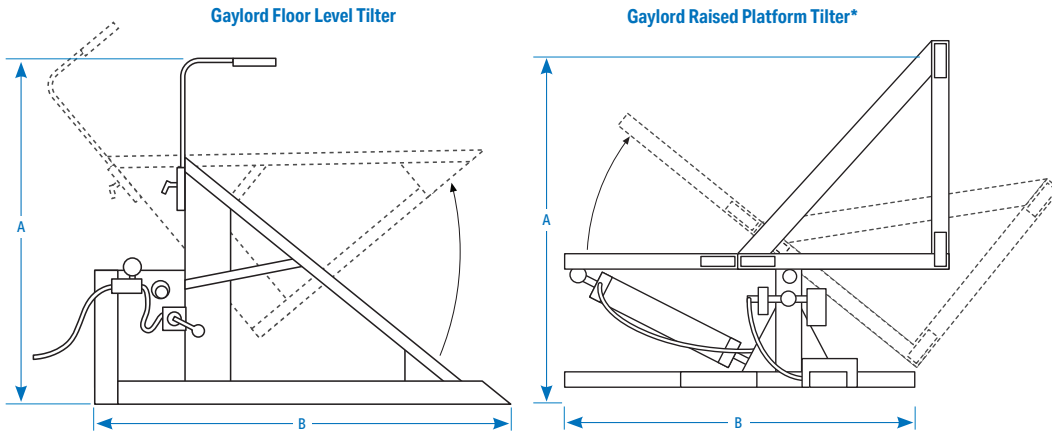

- Electric or pneumatic vibration kits (electric vibration kit requires 110 VAC)
- Full-tilt indicator light
- Gaylord cover

**Specification Notes**

\* Allow a minimum of 30 inches on each side of tilter for working area.

† Height is 54 inches from the floor with wand holder fully extended. Allow for additional height when tilting.

Tilters come standard with the safety ratchet feature. Tilters are available optionally without the safety ratchet, but Conair always recommends utilizing the safety ratchet.

Specifications may change without notice. Consult with a Conair representative for the most current information.

Models	299-276-07	299-276-08	299-276-15	299-276-16	299-276-17	299-276-18	120-004	120-004-01	120-005	120-005-02
<b>Performance characteristics</b>										
Capacity lb {kg}	2500 {1134}						1200 {544}	3000 {1361}		
Tilter type	floor level						raised platform			
Control type	foot	hand	foot/air vibrator	foot/electric vibrator	hand/air vibrator	hand/electric vibrator	foot	foot/air vibrator	foot	foot/air vibrator
<b>Dimensions inch {mm}</b>										
A - Height †	45 {1143}						46.5 {1181}	74 {1880}		
B - Width	58 {1473}						40 {1016}	50 {1270}		
Length	77 {1956}						40 {1016}	50 {1270}		
<b>Weight lb {kg}</b>										
Shipping	465 {211}						540 {245}	1450 {658}		
<b>Compressed air requirement</b>										
	43 psi @ 2 CFM {2.97 bars}						80 psi @ 2 CFM {5.52 bars}			

# How it works

## Raised Platform Tilters

Once placed so that containers can be loaded and removed from the platform, the air regulator is connected to a compressed air supply and a full container is placed on the platform. When the container is about half empty, the operator opens the air flow, inflating a heavy-duty air bag which tilts the platform. The correct adjustment is made when the tilter begins to lift the container. This becomes the correct setting for all future containers of that weight. The hand or foot control remains on at this point and the platform will continue to tilt automatically as material is removed from the container. The tilter can also be manually operated after the container is about half empty and can be leveled by the control for container changes. The larger model 120-005 is designed for heavy container tilting.

## Floor Level Tilters

Once these heavy-duty tilters are placed on a level floor and connected to an appropriate compressed air source, a full container is placed in the platform by a pallet jack, hand truck, or fork truck. When the weight in the container is reduced to approximately 900 lbs (408 kg), the pivot cradle of the tilter begins to automatically tilt the container. The automatic tilting operation continues to direct all the material into one corner of the container, resulting in complete product removal with minimal operator involvement.

