

Mobile Storage; Easy Access

Conair offers a complete line of in-plant mobile surge bins for convenient storage of a variety of materials. Stackable Conair Mobile Surge Bins accommodate your storage needs with a range of bin capacities from 10 ft³ to 50 ft³.* For critical applications requiring a contamination free environment, bins can be constructed in stainless steel with or without lids.

* Usable volume based on a 30° angle of repose.



Model MB44-10
Shown with optional two-piece cover, 4-way vacuum ports, and casters.

Mobile Storage for Blended or Virgin Materials

Conair's Mobile Surge Bins are designed to help you with storage and space issues in your plant. With incorporated two-way fork-lift channels, the bins can be easily lifted and moved from either side. These bins are also easy to stack, allowing you to save valuable plant space by stacking one bin on top of another (up to a maximum of three bins high).

Optional four-way vacuum ports and a 12-inch discharge opening with flange allow for quick and easy evacuation and cleanout of the bin.

Available in painted carbon steel with epoxy coated interior, or optional stainless steel, the Mobile Surge Bin is perfect for any environment, including cleanroom applications, and suitable for any material.

- ▶ **Wide range of capacities**
Usable capacities are available from 350 pounds {159 kg} with the MB44-10 model, to up to 1750 pounds {794 kg} with the MB44-50 model.
- ▶ **60° hopper cone**
The 60° cone ensures material flow for almost all free and non-free flowing materials.
- ▶ **Stackable for space conservation**
Mobile Surge Bins can be stacked up to three bins high to save valuable floor space. This, in conjunction with the small footprint makes these Conair bins an excellent way to maximize your plant square footage.
- ▶ **Bottom drain for easy material removal**
The bottom drain works with the 60° cone to allow for easy material flow out of the bin.
- ▶ **Heavy duty 14 gauge steel construction**
Made to last for years, these Mobile Surge Bins are created to be a reliable piece in your plant. The strong angle-iron frame not only allows for stacking bins, but also protects the cone, vacuum ports and casters (if equipped) from damage.
- ▶ **Oversized vacuum ports**
Suction wands up to three inches in diameter can be used with the Conair Mobile Surge Bins. Another advantage of Conair's experience and design, the oversized vacuum ports allow for quicker cleanout and application variety.

Features

- Painted carbon steel construction
- Epoxy coated interior
- 4-inch square discharge with stainless steel slide gate
- Two-way fork-lift channels for easy stacking
- 60° cone for free and non-free flowing material

Options

- Four-way vacuum ports
- Casters*
- 12-inch discharge opening with flange
- 1 piece, 2 piece sliding cover
- Stainless steel construction
- Special paint
- Bag opening grate and blade

Specifications

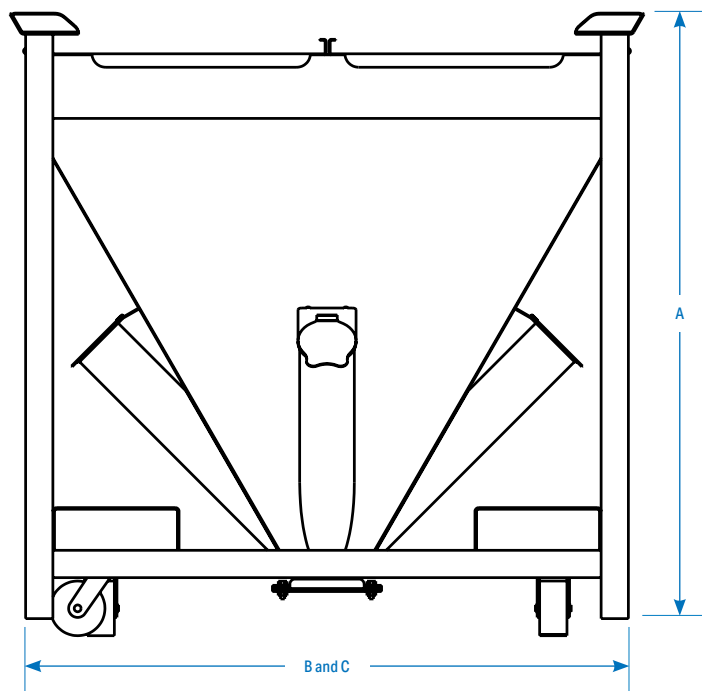

Model	Hopper cone angle (standard)	Width/depth inches (cm) B and C	Height inches (cm) A	Capacity lb (kg)	Usable capacity [†] lb (kg)	Usable volume [†] ft ³ (m ³)	Shipping weight lb (kg)
MB44-10	60°	44 {112}	43.375 {110.2}	665 {302}	350 {159}	10 {0.28}	525 {238}
MB44-20	60°	44 {112}	55.375 {140.7}	1085 {492}	700 {318}	20 {0.57}	580 {263}
MB44-30	60°	44 {112}	64.375 {163.5}	1470 {667}	1050 {476}	30 {0.85}	625 {283}
MB44-40	60°	44 {112}	73.5 {186.7}	1820 {826}	1400 {635}	40 {1.10}	670 {304}
MB44-50	60°	44 {112}	82.5 {209.6}	2170 {984}	1750 {794}	50 {1.40}	720 {327}

Specification Notes

* Adds 1.25 inches {31.8 mm} to height.

[†] Usable capacity based on a material with a bulk density of 35 lbs/ft³ {561 kg/m³} with a 30° angle of repose.

Specifications may change without notice. Check with a Conair representative for the most current information.