



www.conairgroup.com

USER GUIDE

UGC010-1202

Basic 32 Distributed Loader Control

B32-D Model



Please record your equipment's model and serial number(s) and the date you received it in the spaces provided.

Conair recommends recording the model and serial number(s) of your equipment and the date you received it in the User Guide. Our service department uses this information, along with the manual number, to provide help for the specific equipment you installed.

Please keep this User Guide and all manuals, engineering prints and parts lists together for documentation of your equipment.

Date:

Manual Number: UGC010-1202

Serial Number(s):

Model Number(s):

Software Version(s):

Operator Interface

Firmware Version Number:

Application File Name:

Programmable Logic Controller:

Firmware Version Number:

Application File Name:

DISCLAIMER: Conair shall not be liable for errors contained in this User Guide or for incidental, consequential damages in connection with the furnishing, performance or use of this information. Conair makes no warranty of any kind with regard to this information, including, but not limited to the implied warranties of merchantability and fitness for a particular purpose.

TABLE OF CONTENTS

INTRODUCTION	1-1
Purpose of the User Guide.....	1-2
How the Guide is Organized	1-2
Your Responsibility as a User	1-2
ATTENTION: Read this so no one gets hurt	1-3
DESCRIPTION	2-1
What is the B32-D?	2-2
Typical Applications	2-2
How it Works	2-3
Specifications	2-4
INSTALLATION	3-1
Unpacking the Boxes	3-2
Preparing for Installation	3-3
Installing the B32-D	3-4
Wiring Considerations	3-4
Mounting the Base Unit and Power Supply	3-5
Installing the Brackets	3-6
Installing the Bases and Cables	3-7
Installing the Terminal Blocks	3-8
Attaching Power Supply Units	3-9
Installing the I/O Units	3-10
Wiring Pocket Conveying Valves	3-12
Connecting to Main Power	3-12
Starting Up the B32-D	3-13
Initial Setup	3-15
Setting Loader Parameters	3-16
Enabling Loaders	3-17
Enabling Pumps	3-17
Selecting a Password	3-18
OPERATION	4-1
B32-D Control Features	4-2
Viewing Loader Status	4-3
Enabling and Disabling Loaders	4-4
Enabling and Disabling Pumps	4-5
Configuring Loaders	4-6
Assigning Loaders and Pumps	4-7
Addin a Pump or Loader	4-8
Assigning a Backup Pump	4-9
Configuring the Alarm	4-10
Backing up the PLC Program	4-11

TABLE OF CONTENTS

MAINTENANCE	5-1
Preventive maintenance checklist	5-2
TROUBLESHOOTING	6-1
Before Beginning	6-2
A Few Words of Caution	6-2
Identifying the Cause of a Problem	6-3
Clearing Interface Alarms	6-4
Clearing CPU and I/O alarms	6-5
Conveying System Alarms	6-6
Operator Interface Problems	6-8
Processor and power problems	6-8
CPU faults	6-9
I/O errors	6-9
APPENDIX	
Customer service information	A-1
Warranty information	A-2
Restoring the Program	B-1
PARTS/DIAGRAMS	
Wiring Diagrams	
Recommended Spare Parts	

INTRODUCTION

- *Purpose of the User Guide1-2*
- *How the guide is organized1-2*
- *Your responsibilities as a user...1-2*
- *ATTENTION: Read this so
no one gets hurt1-3*

PURPOSE OF THE USER GUIDE

This User Guide describes the Conair Basic 32 Distributed Loader Control and explains step-by-step how to install, operate, maintain and repair this equipment.

Before installing this product, please take a few moments to read the User Guide and review the diagrams and safety information in the instruction packet. You also should review manuals covering associated equipment in your system. This review won't take long, and it could save you valuable installation and operating time later.

HOW THE GUIDE IS ORGANIZED

Symbols have been used to help organize the User Guide and call your attention to important information regarding safe installation and operation.



Symbols within triangles warn of conditions that could be hazardous to users or could damage equipment. Read and take precautions before proceeding.



Numbers within shaded squares indicate tasks or steps to be performed by the user.



A diamond indicates the equipment's response to an action performed by the user.



An open box marks items in a checklist.



A shaded circle marks items in a list.

YOUR RESPONSIBILITY AS A USER

You must be familiar with all safety procedures concerning installation, operation and maintenance of this equipment. Responsible safety procedures include:

- Thorough review of this User Guide, paying particular attention to hazard warnings, appendices and related diagrams.
- Thorough review of the equipment itself, with careful attention to voltage sources, intended use and warning labels.
- Thorough review of instruction manuals for associated equipment.
- Step-by-step adherence to instructions outlined in this User Guide.

We design equipment with the user's safety in mind. You can avoid the potential hazards identified on this machine by following the procedures outlined below and elsewhere in the User Guide.

 **ATTENTION:**
READ THIS SO NO
ONE GETS HURT



WARNING: Improper installation, operation or servicing may result in equipment damage or personal injury.

This equipment should be installed, adjusted, and serviced by qualified technical personnel who are familiar with the construction, operation and potential hazards of this type of equipment.

All wiring, disconnects and fuses should be installed by qualified electrical technicians in accordance with electrical codes in your region. Always maintain a safe ground. Do not operate the equipment at power levels other than what is specified on the the equipment serial tag and data plate.



WARNING: Electrical shock hazard

This equipment is powered by electrical voltage as specified on the machine serial tag and data plate.

A properly sized conductive ground wire from the incoming power supply must be connected to the chassis ground terminal inside the Input/Output enclosure. Improper grounding can result in personal injury and erratic machine operation.

Always disconnect and lock out the incoming main power source before opening the electrical enclosure or performing non-standard operating procedures such as troubleshooting or routine maintenance. Only qualified personnel should perform troubleshooting procedures requiring access to the electrical enclosure while power is on.

DESCRIPTION

- *What is the B32-D?2-2*
- *Typical Applications2-2*
- *How it Works2-3*
- *Specifications2-4*

WHAT IS THE B32-D?

The B32-D provides I/O electronics near each loader in the system, then connects all the I/O modules with simple flat media cable. The B32-D main control box contains only the operator interface station plus a control processor and an interface to the I/O network. This control system configuration greatly simplifies installation, reducing labor and wire costs and allows system expansion by simply adding more I/O modules.

The B32-D is designed to control up to 48 loaders and 8 vacuum pumps with 1 standby pump. In its current configuration it has all the options of the B32-D except proofing and a remote terminal (both of these options may be added in the future). Both 6" and 10" color touchscreens are available.

The B32-D system uses Allen Bradley ArmorBlock I/O modules for loaders and pumps. The modules are clamped onto Kwik-Link flat DeviceNet cable. The DeviceNet flat cables (one for solenoid power, one for electronics/communications) are typically run around the plant in one continuous routing.

TYPICAL APPLICATIONS

The Basic 32-D has been designed for central material conveying applications.

Loader-pump assignments are completely flexible. Individual vacuum receivers can be assigned to any one of the eight loading systems. Each receiver can be configured for one of the following:

- Single-material loading.
- Ratio loading, with or without automatic material layering.
- Positive (air-operated) receiver discharge.
- Material line purging.
- Loader fill alarm to work with an optional fill sensor mounted in the receiver body or direct feed chamber.
- Hopper fill alarm to work with a demand sensor mounted in a drying hopper or other material vessel.
- No alarm.

How It Works

The B32-D communicates with each pump, vacuum receiver and material valve wired to ArmorBlock modules within the devicenet network. The B32-D controls conveying operation based on settings the operator enters on the HMI.

When receivers in a pump system demand material, the B32-D turns on the vacuum pump and dust collector in the appropriate pump system. It then opens the correct vacuum and material valves to convey material to satisfy the demand.



The overview screen lets the operator monitor the status of all vacuum receivers at a glance. Icons indicate the real-time status of each receiver.

Other screens allow you to change system settings or to view pump systems, loader details, alarm histories.



SPECIFICATIONS

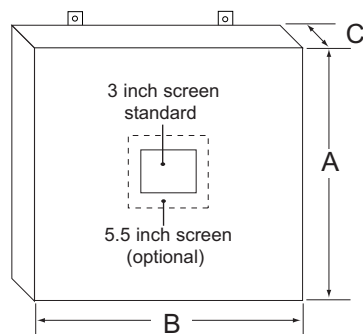

MODEL	B32-D
Performance characteristics	
Maximum number of vacuum receivers	32
Maximum number of vacuum pumps	8 (plus back-up)
Programmable logic controller	Allen Bradley Micrologix 1500
Touchscreen operator interface	Allen Bradley PV300 Micro
Communications with master control	DH485
Screen size, inches {mm}	2.87 X 1.67 {73 X 42}
User interface method	Keypad
Output voltage to receivers/valves	24 VDC
Sensor voltage to receivers	24 VDC
Output voltage to pumps	24 VDC
Dimensions inches {mm}	
Master control cabinet	
A - Height	20 {508}
B - Width	20 {508}
C - Depth	8.6 {219}
Weight lb {kg}	
Installed	60 {27.2}
Shipping	75 {34}
Voltages Total amps	
115V/1 phase/60Hz (master control)	10

SPECIFICATION NOTES:

B32-D loader control cable: 18 gauge shielded, 8-conductor may be used for standard vacuum receivers with up to one optional output and input, otherwise 10-conductor cable is required.

Specifications can change without notice. Check with your Conair representative for the most current information.

APPLICATION NOTES:

Conair vacuum receivers come equipped with a quick-disconnect connector set that includes 10 feet of cable. Junction boxes must be provided to connect the system cable and each vacuum receiver's connector set.

CALCULATING CABLE LENGTH:

Total the distances from the Input/output Station(s) location to each vacuum receiver on the system. Be sure to account for reasonable slack at each loading station for connections, cable routing, etc.

INSTALLATION

- *Unpacking the Boxes*3-2
- *Preparing for Installation*3-3
- *Installing the B32-D*3-4
- *Wiring Considerations*3-4
- *Mounting the Base Unit and
Power Supply*3-5
- *Installing the Brackets*3-6
- *Installing the Bases and Cables*3-7
- *Installing the Terminal Blocks*3-8
- *Attaching the Power Supply Units*3-9
- *Installing the I/O Units*3-10
- *Wiring Pocket Conveying Valves*3-12
- *Connecting to Main Power*3-12
- *Startin up the B32-D*3-13
- *Initial Setup*3-15
- *Setting Loader Parameters*3-16
- *Enabling Loaders*3-17
- *Enabling Pumps*3-17
- *Selecting a Password*3-18

UNPACKING THE BOXES

The B32-D distributed loading control comes in one or more boxes, depending on the options ordered. The boxes should include:

- Base unit with touchscreen interface panel;
- Power supply unit;
- ArmorBlock I/O modules and bases;
- DIN blocks and bases;
- Termination blocks and bases;
- Kwik-Link flat DeviceNet cable;
- Cable installation brackets.

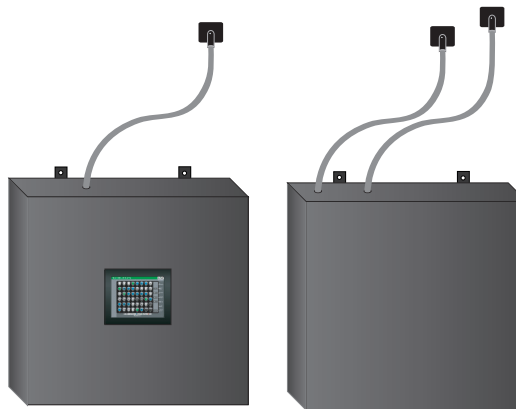

Master Control Unit
with Touchscreen
Interface Panel

Power Supply Unit

- 1** Carefully remove the B32-D components from their shipping containers, and set upright.
- 2** Remove all packing material, protective paper, tape and plastic.
- 3** Carefully inspect all components to make sure no damage occurred during shipping. Notify the shipper immediately if damage is found.
- 4** Take a moment to record serial numbers, the software version number and electrical power specifications in the blanks provided on the back of the the User Guide's title page. The information will be helpful if you ever need service or parts.
- 5** You are now ready to begin installation. Follow the preparation steps on the next page, paying particular attention to all wiring consideration and recommendations.

PREPARING FOR INSTALLATION

You should plan the location of the B32-D base unit to ensure easy access and minimal wiring. Remote touchscreen panels can be connected to the control via an ethernet port inside the control enclosure of the primary touchscreen interface.

1 Select a mounting location for the base unit.

The base unit interface can be mounted on a wall or other stable vertical surface. Select a location that:

- ❑ **Is central to loaders that the B32-D will control.**
Keep the B32-D base unit as close as possible to the loading stations to minimize the amount of wire needed to connect the vacuum receivers to the control.
- ❑ **Provides adequate clearance for safe operation and maintenance.** The base unit should be mounted at a height that allows the operator to easily see and use the touch screen. An external keyboard, if used, should be located on a stable horizontal surface within sight of the touchscreen. Maintain at least 3 feet (1 m) clearance in front of the base unit for safe access to the Input/Output enclosure.
- ❑ **Provides a clean, dry, vibration-free environment.**
Exposure to wide temperature variations, high ambient temperature, power line fluctuations, caustic fumes or excessive amounts of dust, dirt, vibration, shock and moisture could harm performance and reduce the life of this equipment.
- ❑ **Provides a grounded source of 115 VAC power.** The three-prong power cords supplied with the B32-D base unit and power supply requires a grounded 115 VAC outlet rated for at least 15 amp service.

2 Plan the power/communication cable routes.

- ❑ **Review all wiring guidelines and diagrams** provided in the manuals and electrical diagrams supplied with the B32-D system and your conveying equipment before beginning installation. See [WIRING CONSIDERATIONS](#).
- ❑ **Keep communication wires away from sources of static electricity.** Static electricity can damage the controls. Communication cables should *not* be run near the material lines and hoses, which produce large amounts of static electricity when material is conveyed.
- ❑ **Avoid running communication cables across power feed lines.** If you must run the cable across power feed lines, run the cable at right angles to the lines.

INSTALLING THE B32-D

Installation consists of:

- Installing the Kwik-Link flat DeviceNet cables.
- Installing the ArmorBlock bases and termination blocks.
- Installing the ArmorBlock I/O units.
- Mounting the base unit and power supply.
- Installing the loader drop cables.
- Wiring the purge and pocket valves included in the system.
- Installing the drop cables between the pump ArmorBlocks and the pump starters.
- Initial setup of the system control.

WIRING CONSIDERATIONS



WARNING: Improper installation may result in equipment damage or personal injury.

- **Disconnect and lock out the main power supply** to equipment in the conveying system before attempting to wire power and communication cables between the B32-D control, vacuum receivers, pumps, dust collectors and material valves.

- **Install all wiring, disconnects and fuses in accordance** with electrical codes in your region. All electrical installations should be done only by qualified electrical technicians.

- **Always refer to the wiring diagrams supplied with your control** before making electrical connections. The diagrams show the most accurate electrical component information.

- **Protect communication cables from sources of static electricity and electrical noise.**

- Use shielded cable or run wire through a contiguous metal conduit or wireway. Failure to use a metal shield can expose the controls to static electricity, which can damage electronic components.
- Do not run communication cables near material lines and hoses, which produce large amounts of static electricity when conveying material.
- Keep communication cables at least 5 ft. (1.5 m) from electric motors, transformers, rectifiers, arc welders, generators, induction furnaces and sources microwave radiation.
- Avoid running communication cable across power feed lines. If you must run cable across power lines, run the cable at right angles to the line. Keep the cable at least 6 inches (0.15 m) from AC power lines of less than 20 A; 1 foot (0.30 m) from lines of 20A to 100 kVA; and 2 feet (0.60 m) from lines of 100 kVA or more.

- **Always maintain a safe ground. Follow the safe grounding procedures** in the wiring diagram package. Ground the shielded cable inside the Input/Output enclosure only.

- **Do not operate the equipment at power levels other** than those specified on the the equipment data plate.

The B32-D base unit and power supply should be mounted on a wall, or other secure vertical surface, at a height providing easy access and a clear view of the touchscreen panel.



MOUNTING THE BASE UNIT AND POWER SUPPLY

1 Bolt the base unit and
power supply to the mounting
surface. Use the mounting brackets on the base unit
enclosures.

2 Ground the base unit cabinet.
Connect a ground wire to the base unit enclosure. Follow
procedures outlined by your regional electrical codes and
the wiring diagrams included with this manual.

INSTALLING THE BRACKETS



WARNING: Improper installation may result in equipment damage or personal injury.

Always refer to the wiring diagrams that came with your controls before making electrical connections. The diagrams show the most accurate electrical component information.

It is important to keep the communication wires away from conveying lines, which can produce large amounts of static electricity.

- 1 Install the Kwik-Link flat DeviceNet cable brackets provided or prepare your chosen method of cable support.**



- 2 Install the two Kwik-Link flat DeviceNet cables. The gray cable provides communications and inputs; the black cable provides output power. Insure that the cables are installed so that the tabbed edge of the cable may be installed into the ArmorBlock bases and termination blocks correctly.**



- 3 Install the ArmorBlock base brackets or prepare your chosen method of ArmorBlock support wherever there is a loader or a pump.**

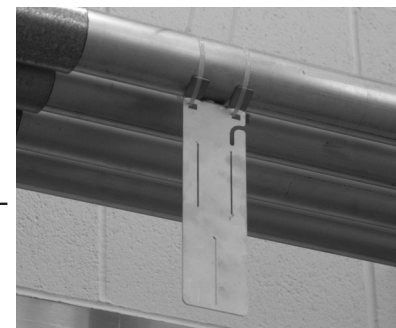

INSTALLING THE BASES AND CABLES

- 1** Install the ArmorBlocks bases on the base brackets.



- 2** Install the Kwik-Link flat DeviceNet cables in the ArmorBlock bases. Insure that the cables are properly installed in the bases and the piercing caps are clamped evenly. If the cables are not flat in their slots, the contacts will not pierce the cables correctly. Remove the bases and discard. Install a new base 1/2 inch to 1 inch from the rremoved base. Refer to Allen Bradley ArmorBlock MaXum I/O Cables Bases Manual (Publication 1792D-5.9) included with the bases for further details.

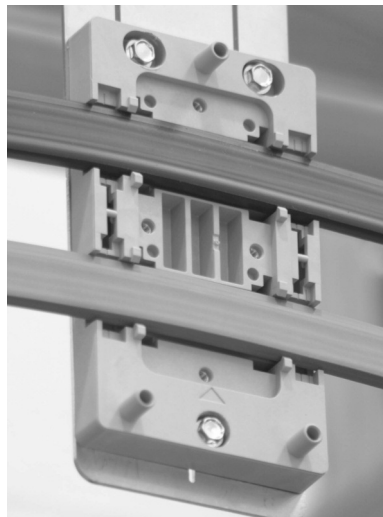

Initially install just two bases, one loader and one pump. The remaining bases can be installed one at a time after the system is powered up.

INSTALLING THE TERMINAL BLOCKS

- 1** **Install the** termination blocks on the two ends of the gray cable. Install any link couplers if the system has multiple segments and multiple power supplies.

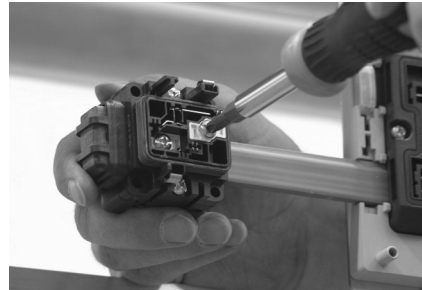
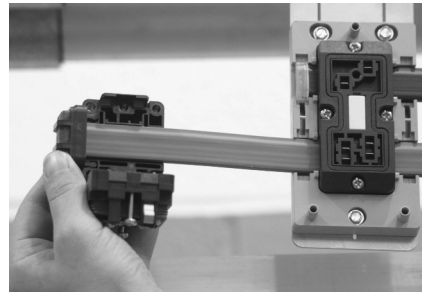

- 2** **Install the base unit** anywhere along the length of the flat cable run within 25 feet of the cable. Install the DeviceNet Mini-DIN termination tap on the gray flat cable. Connect the base unit to the DeviceNet cable using the attached Mini-DIN connector.



ATTACHING POWER SUPPLY UNITS

- 1** **Install the power supply units along the** DeviceNet cable so that the power from the units will be evenly distributed along the cable. For example if there are ten loaders evenly spaced along a 75 meter cable, the power supply should be placed in the center of the cable with five loaders on one side and five on the other. If nine of the loaders were on one end and the tenth loader on the other end, the power supply should probably be placed somewhere in the middle of the nine loaders on the one end.



Half of the current from the power supply will flow one direction down the auxiliary power cable and half of the current will flow the other direction. If there are questions refer to your Allen-Bradley DeviceNet Cable System Planning and Installation Manual (Cat. No. DN-6.7.2), or contact your Conair Representative. Install the power supply units within 25 feet of the DeviceNet cable.

- 2** **Install the two power supply taps on the** DeviceNet cable. The two power supply cables from the power supply unit must be placed on the correct flat cable. The cable marked “DeviceNet Power Supply” should be attached to the gray DeviceNet cable and the cable marked “Auxiliary Power” should be attached to the black auxiliary power cable.



INSTALLING THE I/O UNITS

1 Install the ArmorBlock I/O units on the bases.
 Set the rotary switches on the bottom of the block to the desired node number:

Node Designation	
Loaders, 1 to 32	Nodes 01-32
Pumps, 1 to 8	Nodes 33-40
Backup Pump	Node 41
Scanner	Node 00

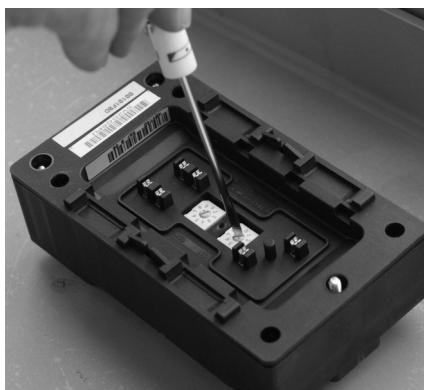

Mark the white tag on the block with the node number for future reference. Please refer to Allen Bradley ArmorBlock MaXum 4 Input/4 Output Module Manual (Publication 1792D-IN012B-EN-P) included with the ArmorBlocks for further details.



2 Install the loader drop cables between the ArmorBlocks and the Universal Terminal Boxes (UTB).
 The connectors should be installed on the ArmorBlocks so that the connector with four wires is installed on the upper left ArmorBlock connectors. Install the connector with three wires on the upper right ArmorBlock connectors. The final loader drop cable connector should be installed on the lower right hand ArmorBlock connector.

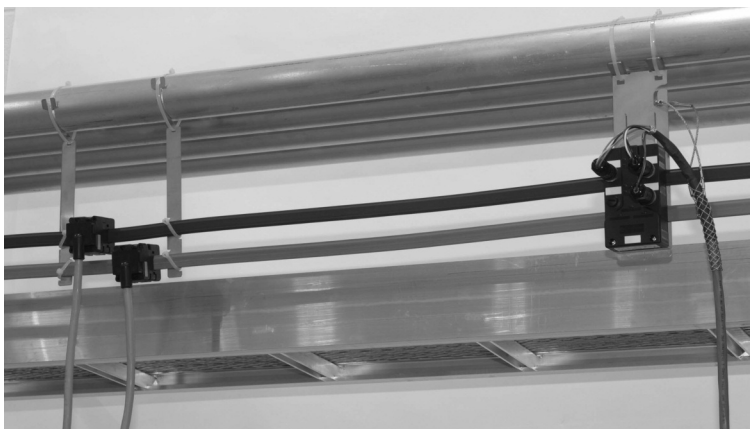

3 Install the wiring for any purge and pocket valves included with the system. The purge/pocket valve should be wired from the junction box on the valve to the nearest Universal Terminal Box (UTB). The wiring should be connected to the UTB using the supplied green Phoenix connector. The pocket valve is given a number based on the loader it is connected to. For example the pocket valve that is connected to loader number 12's UTB will be addressed as material source number 12 in the settings screen.

4 Install the drop cables from the pump ArmorBlocks to the pump starters. Insure that the input side of the ArmorBlock goes to the input connection on the starter and that the output side of the ArmorBlock goes to the output connection on the starter.



The B32-D controller uses the A-B 1769 SDN deviceNet scanner to communicate with the ArmorBlock I/O. To communicate with the I/O the switch setting on the module must be set and the corresponding side on the operator interface must be activated. Nodes not active and on the system display on the status screen as I. All changes are committed to non-volatile memory after exiting the screen.

The indicators showing slave status and scan status display on the status screen. Under normal running conditions the scanner shows a status of 0000 for the slave and scanner (with the scanner running).

WIRING POCKET CONVEYING VALVES (OPTIONAL)

The B32-D can operate up to 32 pocket conveying valves, which are used in central drying and distribution systems. The pocket valve allows multiple loaders to draw dry material as needed from a single drying hopper. Since the valves are located at the material source instead of the loader, separate wiring connections to the nearest loader universal terminal box (UTB)B32-D are required.

NOTE: Purge valves and pocket conveying valves connect to the same outputs on the B32-D control. Therefore, pocket conveying valves cannot be used with loaders that are connected to purge valves.

CONNECTING TO MAIN POWER

The B32-D base unit and power supply are equipped with a three-prong plugs and power cords.

- 1 Plug the power cords into grounded 115 VAC outlets rated for at least 15 Amp service.**
- 2 Make sure the base unit is grounded.**



WARNING: Electrical shock hazard

Failure to provide proper grounding can cause control malfunctions and could result in personal injury from electrical shock.

The control must be connected to a grounded power source. A properly sized conductive ground wire must be connected to the chassis ground terminal inside the base unit enclosure.

STARTING UP THE B32-D

- 1** Once the system is completely assembled check that all connections are terminated correctly.
- 2** Turn on the power supply unit and test to make sure that power is correctly distributed. It is recommended that you remove the ArmorBlock that is located farthest from the power supply and, using a voltmeter, check to insure that both the DeviceNet and Auxiliary power is 24 VDC.
- 3** Once the power supply unit is turned on, check each ArmorBlock to insure that the Auxiliary Power LED is on and glowing green. If not, the ArmorBlock base is not clamped correctly and will need to be removed, discarded, and a new base installed. Install the new base so that the piercing contacts enter the flat cable at a different location than the incorrectly mounted base. It is also possible that the ArmorBlock may be bad. In this case, a known good ArmorBlock should be temporarily fitted to the base to check if the ArmorBlock module may be bad.

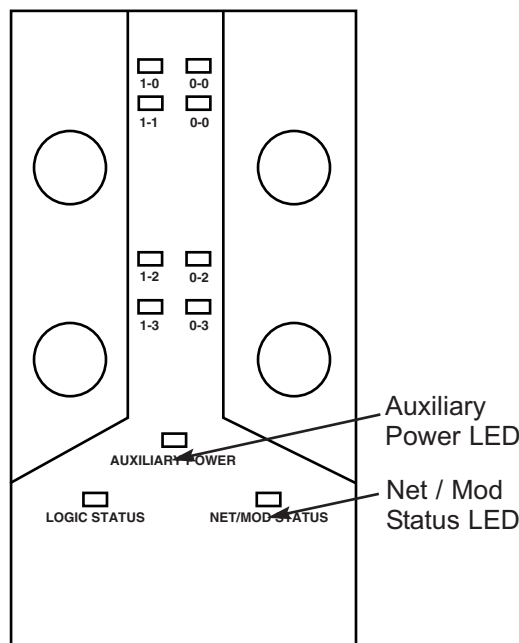

STARTING UP THE B32-D

NOTE: ArmorBlocks and bases can be added or removed from the system while the system is powered on.

- 4** Once the first two ArmorBlocks display a green Auxiliary Power LED, turn on the power switch on the base unit to start the controller and touchscreen. With the processor in run mode, check all the ArmorBlocks for the condition of the Net/Mod Status LED. For loader 1 (node address 01) and pump 1 (node address 51), the LEDs display as solid green indicating that the loader and pump are enabled (factory default). On all other ArmorBlocks, the Net/Mod status LED show as blinking red or blinking green. If any block shows a solid red Net/Mod status light, either the address is incorrect on the rotary switches for one or more blocks may be defective. Check all switch positions and correct/replace the block(s) as necessary.
- 5** When the ArmorBlocks show solid green, blinking red, and the Net/Mod status LEDs blinking green, the enable the nodes via the operator interface. See *INSTALLING THE I/O UNITS* in the Installation section of this manual. When a node is enabled, the blinking red light changes to solid green (this may take a few seconds).
- 6** Install remaining ArmorBlock base and ArmorBlocks, one at a time. Enable the blocks as they are installed and check the status LEDs for the correct status.
- 7** After ArmorBlocks are enabled and show a solid green Auxiliary Power LED and a solid green Net/Mod Status light, the system is ready to run.

INITIAL SETUP

Before you can begin conveying, you must configure and identify the loaders and conveying features you want to use.

Procedures on the following pages will explain how to:

- Set loader parameters
- Enable pumps and loaders
- Select security password

To begin initial setup:

1 Turn on power to the B32-D.

The Power ON/OFF switch is on the left side of the control enclosure.

2 Wait for the control to boot.

Do not touch the control until it completes the bootup and initialization process. Process takes a few seconds. When the control has initialized, the Main Screen displays.

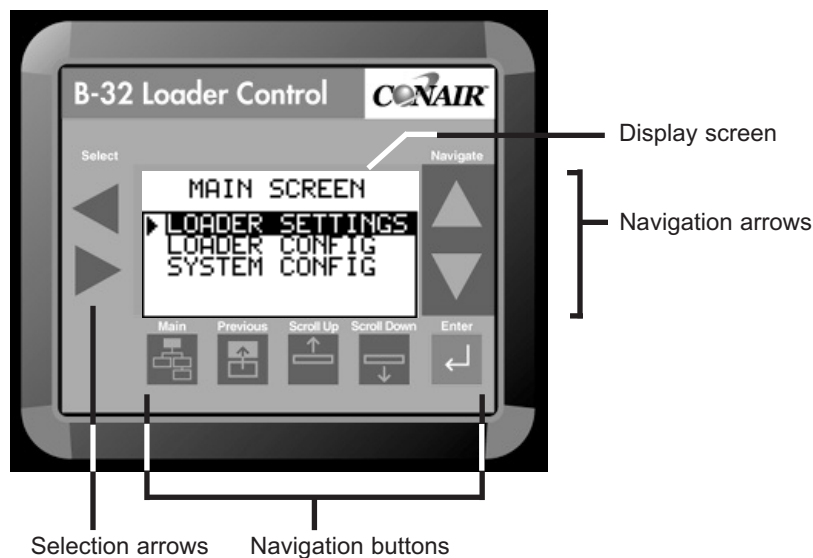

SETTING LOADER PARAMETERS



CAUTION: Incorrect configurations will cause the B32-D control to stop.

Before enabling loaders and loading functions, make sure the loader, valve or option has been installed in the system. Each loader and feature must be wired to a correctly installed and enabled input or output module. The B32-D will fault and the loading control will stop if the required I/O module has not been installed for the feature you enabled.

The loader must be correctly installed and wired before setting parameters.

To set loader parameters from the main screen:

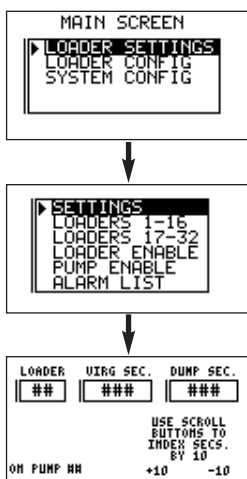

1 Use the Up/Down arrows to scroll to Loader Settings.



2 Press the Enter arrow.

The Loader Settings screen displays. Use the up/down arrows to scroll to Settings.



3 Press the Enter arrow.

The Settings screen displays. Use the left/right arrows to scroll to move the cursor to the Loader field. Use the up/down arrows to select loader.



4 Use the Scroll Down/Up buttons to set the loader

parameters: loader number, virgin time in seconds, dump time in seconds and pump number.



To enable the loaders from the main screen:

- 1 Use the Up/Down arrows to scroll to Loader Settings.**
- 2 Press the Enter arrow.**
The Loader Settings screen displays. Use the up/down arrows to scroll to Loader Enable.
- 3 Press the Enter arrow.**
The Loader Enable screen displays. Use the up/down arrows to increase and decrease the loader number. Use the scroll down/up buttons to enable/disable the loader.



ENABLING LOADERS

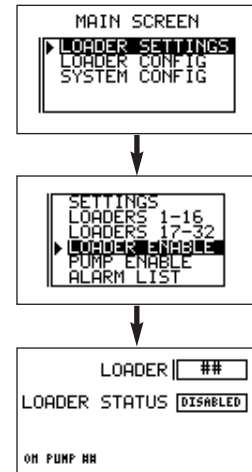

To enable the pumps from the main screen:

- 1 Use the Up/Down arrows to scroll to Loader Settings.**
- 2 Press the Enter arrow.**
The Loader Settings screen displays. Use the up/down arrows to scroll to Pump Enable.
- 3 Press the Enter arrow.**
The Pump Enable screen displays. Use the up/down arrows to increase and decrease the pump number. Use the scroll down/up buttons to enable/disable the pump.



ENABLING PUMPS

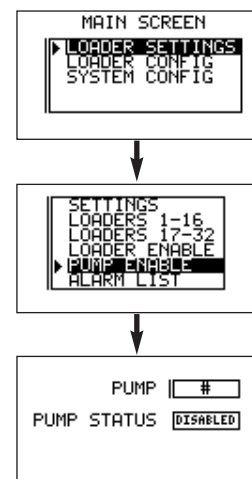

SELECTING A PASSWORD

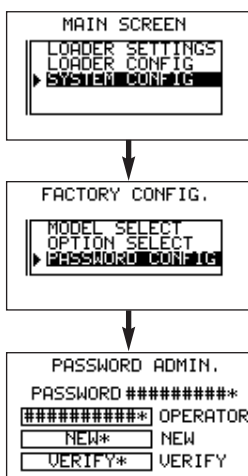

The B32-D provides password security to prevent unauthorized changes to loader or system settings.

1 Use the Up/Down arrows to scroll to  System Config. Entering the System Configuration screen requires a Supervisor 2 password.

2 Enter the password.  To enter the password use the up/down arrows to scroll through the alphanumeric list. When the correct letter/number is highlighted use the right Select arrow to move to the next digit. Continue until the whole password is selected. The initial passwords are set at the factory:

- Supervisor 1: 7373
- Supervisor 2: 54647

Change these passwords and record the new passwords in a safe place.

3 Press the Enter arrow.  The Factory Configuration screen displays. Use the scroll up/down buttons to scroll to the New field. Use the up/down arrows to scroll through the alphanumeric list. When the correct letter/number is highlighted use the right Select arrow to move to the next digit. Continue until the whole password is selected.

4 Press the Enter arrow.  The Password Administration screen displays. Use the up/down arrows to scroll through the alphanumeric list. When the correct letter/number is highlighted use the right Select arrow to move to the next digit. Continue until the whole password is selected.

5 Press the Enter arrow to accept the  password.

6 Press the Main button to return to the  main screen.

OPERATION

- *B32-D Control Features*4-2
- *Viewing Loader Status*4-3
- *Enabling and Disabling*
 - Loaders*4-4
- *Enabling and Disabling*
 - Pumps*4-5
- *Configuring Loaders*4-6
- *Assigning Loaders and Pumps* ...4-7
- *Adding a Pump or Loader*4-8
- *Assigning a Backup Pump*4-9
- *Configuring the Alarm*4-10
- *Backing up PLC Program*4-11

B32-D CONTROL FEATURES

The B32-D operator interface allows you to view the status of the vacuum receivers and pumps in your conveying system at a glance. It also provides access to screens to enter settings for each loading station, view alarms and change system parameters.

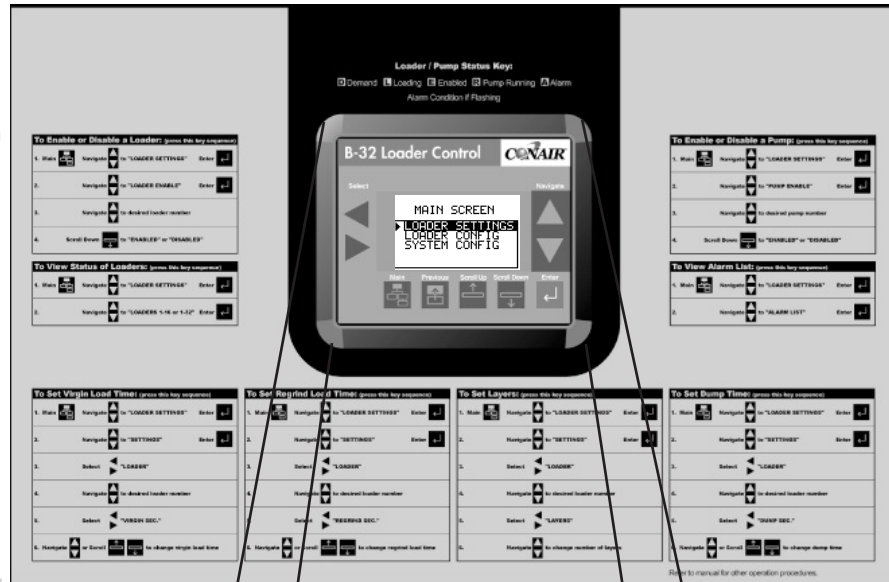

Quick-reference guides

Scroll to:

- Enable/disable loaders and pumps
- Set load times, layers and dump times
- View loader status and

Loader Settings

Scroll to:

- Set loader parameters
- View loader status
- Enable loaders
- Enable pumps
- View alarm list

System Configuration

Prevent accidental or unauthorized changes to system settings with security password.

Loader Configuration

Allows you to:

- Configure a loader
- Assign a loader to a pump
- Assign a backup pump
- Configure loader alarms
- Backup PLC program and settings
- Restore a program
- Display and clear PLC errors



To view loader status from the main screen:

1 Use the Up/Down arrows to scroll to Loader Settings.



2 Press the Enter arrow.

The Loader Settings screen displays. Use the up/down arrows to scroll to Loader 1-16.



3 Press the Enter arrow.

The Loader Status screen displays. The current status of each loader and pump displays. The status choices include:

- E** - enabled
- D** - in demand
- L** - loading
- - disabled
- R** - running

The status of up to 16 loaders and four pumps display status on each screen.

4 Use the Scroll Down/Up buttons to view the remaining loaders and pumps.



VIEWING LOADER STATUS

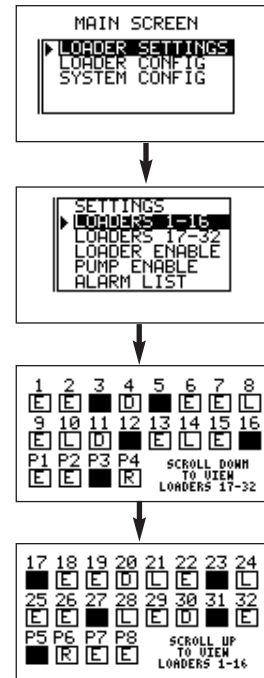

ENABLING AND DISABLING LOADERS



WARNING: Develop and follow procedures for safe operation of the system to avoid possible injury or equipment damage.







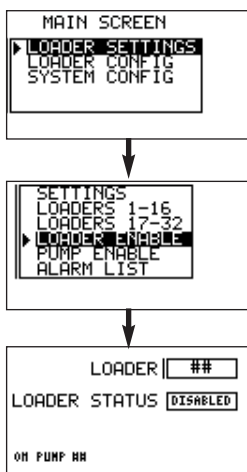

The B32-D allows operators and maintenance personnel to disable and enable conveying system components from remote locations. Unexpected energization of these components could result in equipment damage or injury.

Safe operating procedures should include:

- Disconnect any loader, pump or material valve from main power and/or compressed air sources before servicing. Ensure that all energy sources for the device are locked out and tagged.
- Before removing lockout devices or enabling pumps, loaders or material valves, make sure that all personnel are clear of the machine, tools have been removed and any safety guards have been reinstalled.



To enable the loaders from the main screen:

- 1 Use the Up/Down arrows to scroll to Loader Settings.** 
- 2 Press the Enter arrow.** The Loader Settings screen displays. Use the up/down arrows to scroll to Loader Enable. 

- 3 Press the Enter arrow.** The Loader Enable screen displays. Use the up/down arrows to increase and decrease the loader number. Use the Scroll Down/Up buttons to enable/disable the loader. 

- 4 Press the Enter arrow to save the change.** 
- 5 Press the Previous button to return to the last screen you were viewing, or the Main button to return to the Main screen.** 



WARNING: Develop and follow procedures for safe operation of the system to avoid possible injury or equipment damage.

The B32-D allows operators and maintenance personnel to disable and enable conveying system components from remote locations. Unexpected energization of these components could result in equipment damage or injury.

Safe operating procedures should include:

- Disconnect any loader, pump or material valve from main power and/or compressed air sources before servicing. Ensure that all energy sources for the device are locked out and tagged.
- Before removing lockout devices or enabling pumps, loaders or material valves, make sure that all personnel are clear of the machine, tools have been removed and any safety guards have been reinstalled.

ENABLING AND DISABLING PUMPS

To enable the pumps from the main screen:

- 1 Use the Up/Down arrows to scroll to Loader Settings.**



- 2 Press the Enter arrow.**

The Loader Settings screen displays. Use the up/down arrows to scroll to Pump Enable.



- 3 Press the Enter arrow.**

The Pump Enable screen displays. Use the up/down arrows to increase and decrease the pump number. Use the scroll down/up buttons to enable/disable the pump.



NOTE: When a pump is disabled the loader completes its load cycle before the pump is de-energized.

- 4 Press the Enter arrow to save the change.**



- 5 Press the Previous button to return to the last screen you were viewing, or the Main button to return to the Main screen.**

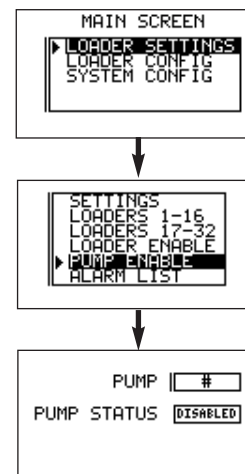



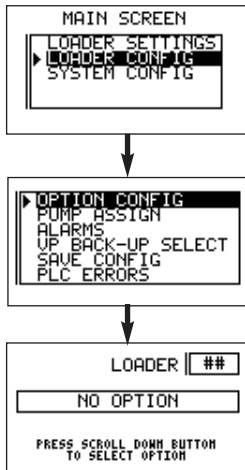





CONFIGURING LOADERS



You may need to change loader settings whenever you change materials or to obtain the best conveying performance.

To configure loaders from the main screen:

- 1 Use the Up/Down arrows to scroll to Loader Config.** 
- 2 Press the Enter arrow.** The Loader Configuration screen displays. Use the up/down arrows to scroll to Option Config. 

- 3 Press the Enter arrow.** The Option Configuration screen displays. Use the up/down arrows to increase and decrease the loader number. Use the scroll down/up buttons to select option:
 - Discharge
 - Ratio
 - Ratio with Calc
 - Purge
 - Material valve
 - No option

- 4 Press the Enter arrow to save the change.** 
- 5 Press the Previous button to return to the last screen you were viewing, or the Main button to return to the Main screen.** 

You may need to change loader and pump assignments to match the conveying system vacuum piping.

To assign loaders and pumps from the main screen:

- 1 Use the Up/Down arrows to scroll to Loader Config.**
- 2 Press the Enter arrow.**
The Loader Configuration screen displays. Use the up/down arrows to scroll to Pump Assign.
- 3 Press the Enter arrow.**
The Pump Assignment screen displays. Use the up/down arrows to choose the loader number. Use the scroll down/up buttons to choose the pump number.
- 4 Press the Enter arrow to save the change.**
- 5 Press the Previous button to return to the last screen you were viewing, or the Main button to return to the Main screen.**



ASSIGNING LOADERS AND PUMPS

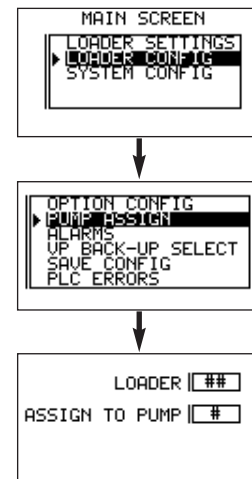



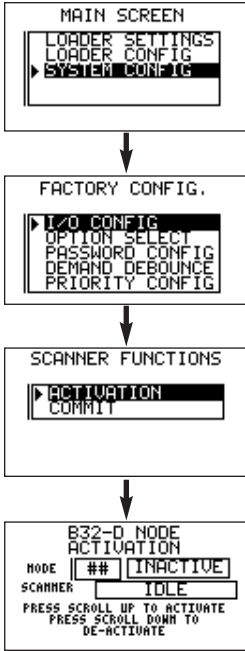

ADDING A PUMP OR LOADER



To add a pump or loader, from the main screen:



1 Use the Up/Down arrows to scroll to System Config. 

2 Press the Enter arrow. The Factory Configuration screen displays. Use the up/down arrows to scroll to I/O CONFIG.  

3 Press the Enter arrow. The Scanner Functions screen displays. Use the scroll down/up buttons to select Activation. The Node Activation screen displays. Use the scroll down/up buttons to select the desired node number.  

Node Designation	
Loaders, 1 to 32	Nodes 01-32
Pumps, 1 to 8	Nodes 33-40

When the node is activated the status field changes from Inactive to Active. The scanner will briefly enter Idle mode and return to Running.

4 Press the Previous button to return to the last screen you were viewing, or the Main button to return to the Main screen.  

A backup pump can be assigned to replace any of the eight pump systems during operation.

To assign a backup pump:

1 Use the Up/Down arrows to scroll to Loader Config.



2 Press the Enter arrow.

The Loader Configuration screen displays. Use the up/down arrows to scroll to VP Back-Up Select.



3 Press the Enter arrow.

The Pump Back-up Select screen displays. Use the scroll down/up buttons to select a backup pump (pumps 1 through 8) or no backup pump.



4 Press the Enter arrow to save the change.



5 Press the Previous button to return to the last screen you were viewing, or the Main button to return to the Main screen.



ASSIGNING A BACKUP PUMP

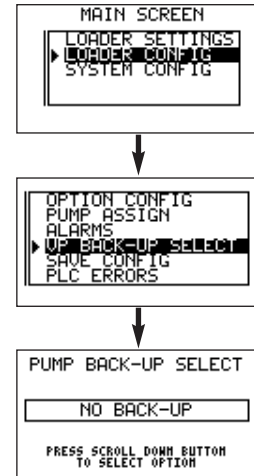



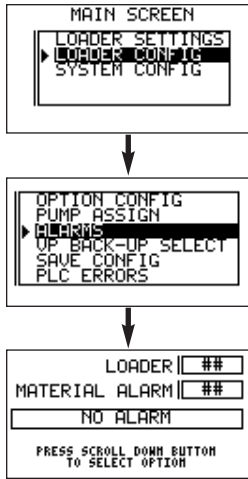

CONFIGURING THE ALARM





The loader can be configured for demand alarm, fill alarm or no alarm.

To configure the alarm from the main screen:

- 1 Use the Up/Down arrows to scroll to Loader Config.** 
- 2 Press the Enter arrow.** 

The Loader Configuration screen displays. Use the up/down arrows to scroll to Alarms. 
- 3 Press the Enter arrow.** 

The Alarm Configuration screen displays. Use the scroll down/up buttons to choose the alarm configuration you want:

 - No alarm
 - Demand alarm
 - Fill alarm
- 4 Press the Enter arrow to save the change.** 
- 5 Press the Previous button to return to the last screen you were viewing, or the Main button to return to the Main screen.** 

MAINTENANCE

- *Maintenance checklist5-2*

PREVENTIVE MAINTENANCE CHECKLIST

You should develop a preventive maintenance schedule for all components in the conveying system to ensure optimum operation and performance.

The B32-D may require the following maintenance checks:

- **Whenever you change materials**

- Verify the loader settings** for pump systems or loaders effected by the material change. Pay particular attention to load times and dump times. See **CHANGING LOADER SETTINGS** in the Operation section.

- **Quarterly**

- Check power and cable connections and wires.**
Over time, the power and cable connections between the B32-D and conveying system components may become loose or wires may become worn. Tighten any loose connections and replace any wire or cable that has become worn or damaged.

TROUBLESHOOTING

- *Before Beginning*6-2
- *A Few Words of Caution*6-2
- *Identifying the Cause of a Problem*6-3
- *Clearing Interface Alarms*6-4
- *Clearing CPU and I/O alarms* ...6-5
- *Conveying System alarms*6-6
- *Operator Interface Problems*6-8
- *Processor and Power Problems.* 6-8
- *CPU faults*6-9
- *I/O errors*6-9

BEFORE BEGINNING

Before you begin troubleshooting:

- Find the manuals and wiring diagrams that were shipped with your equipment.

These materials contain details you will need to diagnose and repair problems in specific components, including custom wiring, features or I/O options not covered in this User Guide.

A FEW WORDS OF CAUTION



WARNING: Improper installation, operation or servicing may result in equipment damage or personal injury.

The B32-D should be installed, adjusted, and serviced only by qualified technical personnel who are trained in the operation and troubleshooting of this type of equipment.



DANGER: Electrical shock hazard

Diagnosing the cause of electrical system and CPU problems in this equipment may require the use of precision electronic measuring equipment, as well as access to the electrical enclosure while power is on. Only qualified electrical technicians, trained in the use of this equipment and in avoiding exposure to voltage hazards, should perform procedures that require access to the enclosure while power is on.



WARNING: Develop and follow procedures for safe operation and maintenance of the system.

The B32-D allows operators and maintenance personnel to disable and enable conveying system components from remote locations. Unexpected energization of these components could result in equipment damage or injury.

Safe maintenance procedures should include:

- Disconnect any loader, pump or material valve from main power and/or compressed air sources before servicing. Ensure that all energy sources for the device are locked out and tagged.
 - Before removing lockout devices and enabling system components, verify that all personnel are clear of the machine, tools have been removed, and any safety guards have been reinstalled.
-

The TROUBLESHOOTING section explains how to clear an alarm, and provides diagnostic tables to help you determine the cause of the alarm.

Diagnostic tables have been divided into:

❑ Conveying System Alarms.

These tables focus on the “No Material” and “Pump Overload” alarms that the B32-D displays on the Alarm Summary screen. The B32-D continues to control the system and the alarming loading station will load.

❑ Power and Processor Problems.

These tables focus on power supply and processor problems indicated by Micrologix 1500 LEDs located inside the I/O enclosure. These problems cause the B32-D control to stop.

❑ CPU Faults.

These tables focus on Hex error codes that apply to the Micrologix 1500 and are displayed as faults on the Rack & Slot screen. These problems cause the B32-D control to stop.

IDENTIFYING THE CAUSE OF A PROBLEM

IMPORTANT: Refer to the manuals supplied by the manufacturers of loaders, pumps and material valves in your system for additional diagnostic and repair information.

CLEARING INTERFACE ALARMS

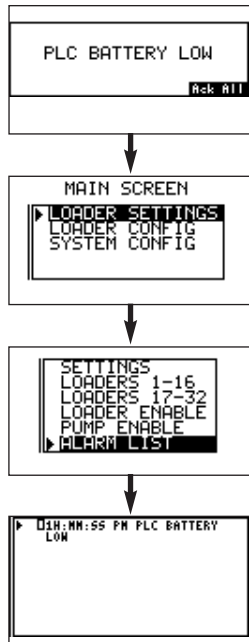



When a conveying problem occurs, the screen displays the alarm message and the audible alarm sounds.



To silence the alarm and fix the problem:

- 1 Press the Enter button.** 

This acknowledges the alarm. The alarm text is removed from the screen. The screen returns to the Main screen. NOTE: pressing the Enter button only acknowledges the alarm; it does not fix the problem.
- 2 View Alarm list.** 

From the Main screen use the Up/Down arrows to scroll to Loader Settings. Press Enter. The Loader Settings screen displays. 
- 3 Use the Up/Down arrows to scroll to Alarm List.** 

Press Enter to display alarms. The alarm list displays up to 25 alarms, starting with the most current. All acknowledged alarms have a check mark next to the text. All alarms show the hour, minute and second the alarm occurred. Alarms are automatically removed from the list when the condition is corrected. 
- 4 Fix the problem.**



Refer to the diagnostic tables in this section and any manuals supplied with this device to determine the cause of the problem and to repair the problem.
- 5 Press Main button to return to main screen**  **or the Previous button to return to the last screen viewed.** 

CPU and Input/Output errors will stop the B32-D control.

These errors may be caused by problems with the power supply, processor or Input/Output modules. The error is indicated by error codes on the PLC Error screen or by LEDs on the B32-D MicroLogix1500 CPU and power supply modules.

To clear and fix a CPU or I/O error from the Main screen:

1 Use the Up/Down arrows to scroll to Loader Config. 

2 Press the Enter arrow. 
The Loader Configuration screen displays. Use the up/down arrows to scroll to PLC Errors. 

3 Press the Enter arrow. 
The Errors screen displays. The alphanumeric error code is listed. The error code is reported in hexadecimal format, with the first two digits identifying a specific I/O module slot. If the digits are 1F, an exact slot cannot be determined. Refer to the Fault Messages and Error Code in the appendix of this manual for a complete listing and follow the recommended action for correcting the error.

4 Clear the error code from the Major Error field by entering four zeros (0000) using the Select Left/Right arrows. 

5 Press the Scroll Down button 
to move to the Reset field. There are three choice available in the Reset field: Fault, Error and OK. Continue to press the Scroll down button until you reach OK.

6 Press the Enter button to save the reset. 
Press the Home button to return to the home screen. 

CLEARING CPU AND I/O ALARMS

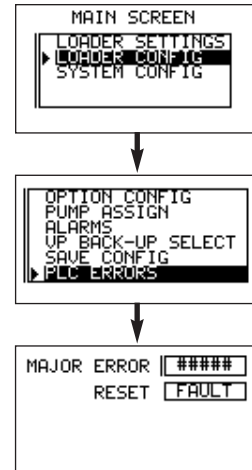

CONVEYING SYSTEM ALARMS

The No Material Alarm can be triggered in two ways:

- The Alarm Check signals an alarm after the operator-set number of consecutive loading attempts fails to satisfy the receiver's demand for material.
- The optional fill sensor in the receiver or hopper is not satisfied after one loading cycle.

Alarm	Possible cause	Solution
No Material Alarm	There is no material at the source.	<ul style="list-style-type: none"> <input type="checkbox"/> Verify that there is enough material at the source, including regrind sources if a ratio valve is used. <input type="checkbox"/> Verify that the material line is connected to the correct source of material.
	Loader Settings are incorrect.	<p>If the parameters set on the Loader Settings screen are incorrect, material demand may not be satisfied.</p> <ul style="list-style-type: none"> <input type="checkbox"/> Verify that the Load Time, or Load Time plus Purge Time, is sufficient to fill the receiver. Adjust as needed. <input type="checkbox"/> Verify that the Alarm Check allows a sufficient number of loading cycles to fill the receiver. Adjust as needed. <input type="checkbox"/> Verify that the loader is assigned to the correct pump system.
	There is a leak in the vacuum system.	<p>If there are leaks in the system, the pump cannot pull a good vacuum and the receiver may have no or little material flowing into it. Check the vacuum pump gauge. If the reading is low, check all hoses, gaskets, receiver lids, and valves for signs of damage or wear. Replace as needed.</p>

CONVEYING SYSTEM ALARMS

Alarm	Possible cause	Solution
No Material Alarm (continued)	Vacuum pump is not working correctly.	Verify that the vacuum pump is on, connected to the B32-D and working correctly. Refer to the pump manual.
	The fill/demand sensor or demand switch is not working properly.	<input type="checkbox"/> Verify that sensors and switches are connected correctly at the loader or hopper and at the control. <input type="checkbox"/> Verify that fill and demand sensors are set at the correct height and adjusted properly. Refer to manuals supplied with the fill or demand signaling device.
	Compressed air lines are not connected correctly.	If a compressed air line is not connected to vacuum or material valves, the valves cannot open to allow the pump to draw material into the receiver. Verify that compressed air lines supplying the correct pressure have been connected to the vacuum sequencing valve, ratio valve, pocket conveying or purge valve.
Pump Overload	The vacuum pump overload has tripped.	This alarm will prevent the pump from being energized until the overload is corrected. Refer to the pump manual to correct the problem.

OPERATOR INTERFACE PROBLEMS



WARNING: Electrical shock hazard

Diagnosing electrical and processor problems require access to the electrical enclosure while power is on. Only qualified electrical technicians, who are trained in how to avoid voltage hazards, should perform troubleshooting procedures that require access to the B32-D Input/Output enclosure while power is on.

Fault	Possible cause	Solution
Terminal does not power up.	Improper connection to power source	<input type="checkbox"/> Verify wiring and connections to power source.
	Incorrect input voltage level.	<input type="checkbox"/> Verify correct voltage is present at power terminals.
	DC power wires reversed (DC terminals only).	<input type="checkbox"/> Make sure DC power positive and negative are connected to the proper terminals.
	Power terminal block not fully seated (PV300 terminals only).	<input type="checkbox"/> Verify power terminal block is snapped onto base of PV300 Micro.

PROCESSOR AND POWER PROBLEMS



WARNING: Electrical shock hazard

Diagnosing electrical and processor problems require access to the electrical enclosure while power is on. Only qualified electrical technicians, who are trained in how to avoid voltage hazards, should perform troubleshooting procedures that require access to the B32-D Input/Output enclosure while power is on.

Fault	Possible cause	Solution
See APPENDIX C “TROUBLESHOOTING YOUR SYSTEM” for a complete listing of process and power faults, causes and solutions.		



WARNING: Electrical shock hazard

Diagnosing electrical and processor problems require access to the electrical enclosure while power is on. Only qualified electrical technicians, who are trained in how to avoid voltage hazards, should perform troubleshooting procedures that require access to the B32-D Input/Output enclosure while power is on.

CPU FAULTS

Error/Alarm	Possible cause	Solution
-------------	----------------	----------

See [APPENDIX D: “FAULT MESSAGES AND ERROR CODES”](#) for a complete listing of CPU faults, causes and solutions.



WARNING: Electrical shock hazard

Diagnosing electrical and processor problems require access to the electrical enclosure while power is on. Only qualified electrical technicians, who are trained in how to avoid voltage hazards, should perform troubleshooting procedures that require access to the B32-D Input/Output enclosure while power is on.

I/O ERRORS

Error	Possible cause	Solution
-------	----------------	----------

See [APPENDIX D: “FAULT MESSAGES AND ERROR CODES”](#) for a complete listing of input/output errors, causes and solutions.

We're Here to Help

Conair has made the largest investment in customer support in the plastics industry. Our service experts are available to help with any problem you might have installing and operating your equipment. Your Conair sales representative also can help analyze the nature of your problem, assuring that it did not result from misapplication or improper use.

Additional manuals and prints for your Conair equipment may be ordered through the Customer Service or Parts Department for a nominal fee. Most manuals can be downloaded free of charge from the product section of the Conair website.
www.conairgroup.com

How to Contact Customer Service

To contact Customer Service personnel, call:



 **NOTE:** Normal operating hours are 8:00 am - 5:00 pm (EST). After hours emergency service is available at the same phone number.

You can commission Conair service personnel to provide on-site service by contacting the Customer Service Department.

Before You Call...

If you do have a problem, please complete the following checklist before calling Conair:

- Make sure you have all model, control type and serial numbers from the serial tag, and parts list numbers for your particular equipment. Service personnel will need this information to assist you.
- Make sure power is supplied to the equipment.
- Make sure that all connectors and wires within and between control systems and related components have been installed correctly.
- Check the troubleshooting guide of this manual for a solution.
- Thoroughly examine the instruction manual(s) for associated equipment, especially controls. Each manual may have its own troubleshooting guide to help you.
- Check that the equipment has been operated as described in this manual.
- Check accompanying schematic drawings for information on special considerations.

Equipment Guarantee

Conair guarantees the machinery and equipment on this order, for a period as defined in the quotation from date of shipment, against defects in material and workmanship under the normal use and service for which it was recommended (except for parts that are typically replaced after normal usage, such as filters, liner plates, etc.). Conair's guarantee is limited to replacing, at our option, the part or parts determined by us to be defective after examination. The customer assumes the cost of transportation of the part or parts to and from the factory.

Performance Warranty

Conair warrants that this equipment will perform at or above the ratings stated in specific quotations covering the equipment or as detailed in engineering specifications, provided the equipment is applied, installed, operated and maintained in the recommended manner as outlined in our quotation or specifications.

Should performance not meet warranted levels, Conair at its discretion will exercise one of the following options:

- Inspect the equipment and perform alterations or adjustments to satisfy performance claims. (Charges for such inspections and corrections will be waived unless failure to meet warranty is due to misapplication, improper installation, poor maintenance practices or improper operation.)
- Replace the original equipment with other Conair equipment that will meet original performance claims at no extra cost to the customer.
- Refund the invoiced cost to the customer. Credit is subject to prior notice by the customer at which time a Return Goods Authorization Number (RGA) will be issued by Conair's Service Department. Returned equipment must be well crated and in proper operating condition, including all parts. Returns must be prepaid.

Purchaser must notify Conair in writing of any claim and provide a customer receipt and other evidence that a claim is being made.

Warranty Limitations

Except for the Equipment Guarantee and Performance Warranty stated above, Conair disclaims all other warranties with respect to the equipment, express or implied, arising by operation of law, course of dealing, usage of trade or otherwise, including but not limited to the implied warranties of merchantability and fitness for a particular purpose.

The program can be restored to the plant configuration if for some reason the program has been interrupted.

To restore the program:

1 Use the Up/Down arrows to scroll to Loader Config.



2 Press the Enter arrow.

The Loader Configuration screen displays. Use the up/down arrows to scroll to Save Config



3 Press the Enter arrow.

The Save Configuration screen displays. Use the scroll up/down buttons to select Program Mode.



4 Press the Enter arrow to save the change.



5 Press the Previous button to return to the last screen you were viewing, or the Main button to return to the Main screen.



RESTORING THE PROGRAM

