

USER GUIDE
UGC034-0108

Easy Loading Control

Models ELC-M and ELC-16



INTRODUCTION • Purpose of the User Guide • How the guide is organized • Your responsibilities as a user • **ATTENTION:** Read this so no one gets hurt • **DESCRIPTION** • What is the Easy Loading Control (ELC)? • Typical applications • How it works • Specifications: Easy Loading Control (ELC) • **INSTALLATION** • Unpacking the boxes • Preparing for installation • Wiring considerations • Mounting the ELC control • Connecting main power to the ELC-M control • Wiring the ELC-16 pump control • ELC-16 control junction boxes • Mounting the ELC-16 control junction boxes • Connecting the junction box ground wire • Wiring the ELC-16 control junction boxes • Connecting the trunk cable termination resistor • Mounting the ELC ControlMate™ pendant (optional) • Connecting the ELC-16 control to the junction box drop cable • Powering the pump control • Powering the ELC Control • **OPERATION** • Easy Loading Control: Control panel layout • ELC loading control operation • ControlMate™ pendant: LED descriptions • ControlMate™ pendant operation • User level 2 settings for the ControlMate™ pendant • **MAINTENANCE** • Preventative Maintenance Checklist • **TROUBLESHOOTING** • Before beginning • A few words of caution • Troubleshooting

Please record your equipment's model and serial number(s) and the date you received it in the spaces provided.

It's a good idea to record the model and serial number(s) of your equipment and the date you received it in the User Guide. Our service department uses this information, along with the manual number, to provide help for the specific equipment you installed.

Please keep this User Guide and all manuals, engineering prints and parts lists together for documentation of your equipment.

Date:

Manual Number: UGC034-0108

Serial Number(s):

Model Number(s):

DISCLAIMER: The Conair Group, Inc., shall not be liable for errors contained in this User Guide or for incidental, consequential damages in connection with the furnishing, performance or use of this information. Conair makes no warranty of any kind with regard to this information, including, but not limited to the implied warranties of merchantability and fitness for a particular purpose.

Table of Contents

1-1 Introduction

Purpose of the user guide	1-2
How the guide is organized	1-2
Your responsibilities as a user	1-3
ATTENTION: Read this so no one gets hurt	1-4

2-1 Description

What is the Easy Loading Control (ELC)?	2-2
Typical applications	2-2
How it works	2-3
Specifications: Easy Loading Control (ELC)	2-4
Optional ControlMate pendant	2-5
Pump control	2-6

3-1 Installation

Unpacking the boxes	3-2
Preparing for installation	3-3
Wiring considerations	3-4
Mounting the ELC control	3-5
Connecting main power to the ELC-M control	3-6
Wiring the ELC-16 pump control	3-7
ELC-16 control junction boxes	3-9
Mounting the ELC-16 control junction boxes	3-10
Connecting the junction box ground wire	3-10
Wiring the ELC-16 control junction boxes	3-11
Connecting the trunk cable termination resistor	3-14

3-1 Installation (continued)

Mounting the ELC ControlMate pendant (optional)	3-17
Connecting the ELC-16 control to the junction box drop cable . . .	3-18
Powering the pump control	3-19
Powering the ELC control	3-20

4-1 Operation

Easy Loading Control: Control panel layout	4-2
ELC loading control operation	4-3
Basic operation	4-3
Load time adjustment	4-4
Alarm acknowledgement	4-5
Using blowback	4-6
ControlMate pendant: LED descriptions	4-8
Connecting the ControlMate pendant	4-10
Enabling/disabling the ControlMate pendant	4-11
Hopper loading with positive discharge option	4-11
Adjusting unload time	4-12
Adjusting the number of load attempts before an alarm	4-13
Adjusting ratio percentage	4-14
Adjusting ratio layers	4-15
Using purge operation	4-16
Adjusting load time	4-18
User level 2 settings for the ControlMate pendant	4-21

5-1 Maintenance

Preventative maintenance checklist	5-2
--	-----

6-1 Troubleshooting

Before beginning 6-2

A few words of caution 6-3

DIAGNOSTICS

Troubleshooting: ELC-M control 6-4

Troubleshooting: ELC-16 control 6-6

Troubleshooting: optional ControlMate pendant
and pump control 6-8

A Appendix

We're here to help A-1

How to contact customer service A-1

Before you call... A-1

Equipment guarantee A-2

Performance warranty A-2

Warranty limitations A-2

Introduction

Purpose of the user guide. 1-2

How the guide is organized. 1-2

Your responsibilities as a user. 1-3

ATTENTION:

 Read this so no one gets hurt 1-4

Purpose of the User Guide

This User Guide describes the Conair Easy Loading Control (ELC) and explains step-by-step how to install, operate, maintain, and repair this equipment.

Before installing this product, please take a few moments to read the User Guide and review the diagrams and safety information in the instruction packet. You also should review manuals covering associated equipment in your system. This review won't take long, and it could save you valuable installation and operating time later.

How the Guide is Organized

Symbols have been used to help organize the User Guide and call your attention to important information regarding safe installation and operation.



Symbols within triangles warn of conditions that could be hazardous to users or could damage equipment. Read and take precautions before proceeding.



Numbers indicate tasks or steps to be performed by the user.



A diamond indicates the equipment's response to an action performed by the user.



An open box marks items in a checklist.



A circle marks items in a list.



Indicates a tip. A tip is used to provide you with a suggestion that will help you with the maintenance and the operation of this equipment.



Indicates a note. A note is used to provide additional information about the steps you are following throughout the manual.

Your Responsibility as a User

You must be familiar with all safety procedures concerning installation, operation and maintenance of this equipment. Responsible safety procedures include:

- Thorough review of this User Guide, paying particular attention to hazard warnings, appendices and related diagrams.
- Thorough review of the equipment itself, with careful attention to voltage sources, intended use and warning labels.
- Thorough review of instruction manuals for associated equipment.
- Step-by-step adherence to instructions outlined in this User Guide.

ATTENTION:

Read this so no one gets hurt

We design equipment with the user's safety in mind. You can avoid the potential hazards identified on this equipment by following the procedures outlined below and elsewhere in the User Guide.



WARNING: Improper installation, operation, or servicing may result in equipment damage or personal injury.

This equipment should be installed, adjusted, and serviced by a qualified technical personnel who is familiar with the construction, operation, and potential hazards of this type of machine.

All wiring, disconnects, and fuses should be installed by a qualified electrical technician in accordance with electrical codes in your region. Always maintain a safe ground. Do not operate the equipment at power levels other than what is specified on the machine serial tag and data plate.



WARNING: Voltage hazard

The ELC-M is powered by single-phase alternating current, as specified on the machine serial tag and data plate.

A properly sized conductive ground wire from the incoming power supply must be connected to the chassis ground or P.E. (physical earth) terminal inside the electrical enclosure. Improper grounding can result in severe personal injury and erratic machine operation. (120 Volt units come with a grounded plug. Must be plugged into a grounded out.)

The ELC-16 is powered by three-phase alternating current via a pump control, then converted to 24DC control voltage.

Always disconnect and lock out the incoming main power source before opening the electrical enclosure or performing non-standard operating procedures, such as routine maintenance. Only qualified personnel should perform troubleshooting procedures that require access to the electrical enclosure while power is on.

Description

What is the Easy Loading Control (ELC)?	2-2
Typical applications	2-2
How it works	2-3
Specifications: Easy Loading Control (ELC) . .	2-4
Optional ControlMate Pendant	2-5
Pump Control	2-6

What is the Easy Loading Control (ELC)?

Conair's Easy Loading Control (ELC) provides users with individual controls at each loader or receiver to allow for specific material and conveying requirements.

Two models are available:

- **ELC-M** - Used to operate a single self-contained loader.
- **ELC-16** - Used over a CAN open network for receiver material demand.
Up to sixteen ELC-16 controls can be connected to the CAN open network.

Typical Applications

- ELC-M - Self-contained unit mounted to a single loader for stand-alone applications, such as filling a large hopper or surge bin.
- Up to 16 ELC-16 - Controls mounted to individual receivers communicating over a CAN open network, for multiple hopper material filling or conveying applications.

How it works

ELC-M Control

A signal from the loader's demand switch indicates to the ELC-M on the loader that it requires material to be conveyed to satisfy its demand. The ELC-M sends a signal to the vacuum motor on the loader to energize and start a loading cycle. The material is then drawn in by the loader's vacuum motor. If the hopper is filled, the demand switch will remain open (Fig. 1) and no further load cycles are needed. However, if the demand was not satisfied and the demand switch closes (Fig. 2) the loader will continue with loading cycles until the demand is satisfied.

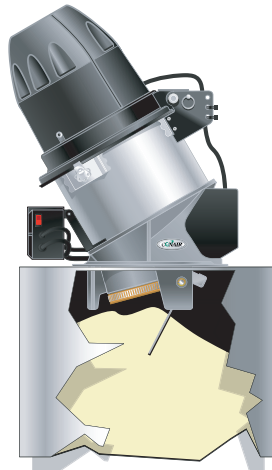

Fig. 1

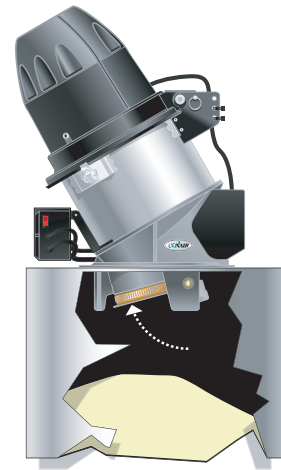
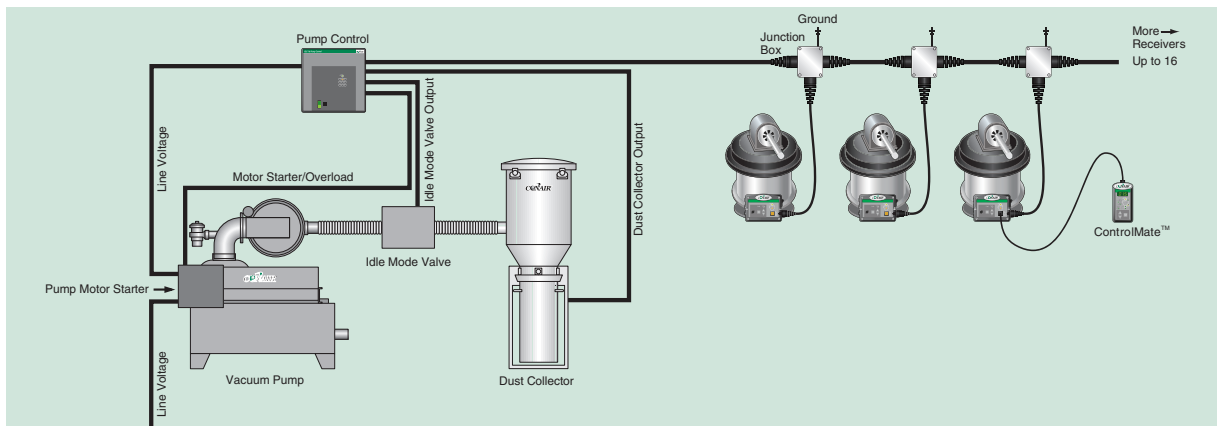

Fig. 2

Description
2

ELC-16 Control



A signal from the receiver's demand switch indicates to the individually mounted ELC-16 on the receiver that it requires material to be conveyed to satisfy its demand. The ELC-16 then communicates its need for material to the pump control via a CAN open network. The demand signal from the ELC is then added to the pump control's queue. The vacuum pump control will then permit the receiver to load on a First-In/First-Out (FIFO) basis.

The ELC-16 control is used for a number of receivers (up to 16) on a CAN open network. The ELC-16 control uses First-In/First-Out (FIFO) for receiver demand. The FIFO setting works within your CAN open network and will allow the receiver that demanded material first to receive it first. For example, if there are four (4) receivers in a series that have demands for material, but the third receiver demanded material first, regardless of the receiver's physical location on the CAN open network, it will be provided with material.

TPC052-0108

Description | 2-3

Specifications: Easy Loading Control (ELC)

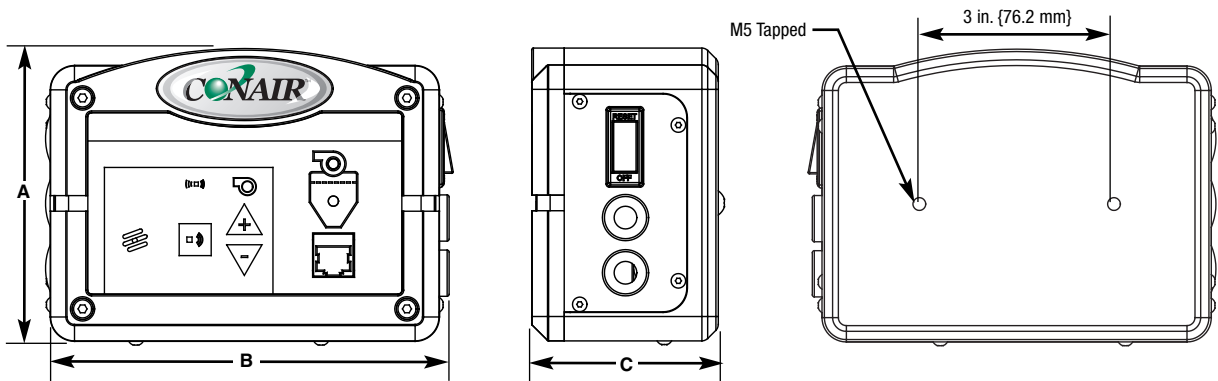

MODELS	ELC-M	ELC-16
Supply voltage	115VAC 50Hz, 230VAC 50/60Hz 24VDC (from pump control)	
Pump control voltage full load amps		
230VAC/60Hz	NA	0.64
400VAC/50Hz	NA	0.37
460VAC/60Hz	NA	0.32
Control dimensions inches {mm}		
A - Height	4.5 {114.4}	4.5 {114.4}
B - Width	6.0 {152.4}	6.0 {152.4}
C - Depth	2.9 {73.0}	2.9 {73.0}
Control weight lb {kg}		
Installed	7.6 {3.4}	7.6 {3.4}
Shipping	9.1 {4.1}	9.1 {3.4}

CALCULATING ELC-16 SYSTEM CABLE LENGTH:

Total the distance from the vacuum pump power supply to the last loading station. Account for reasonable slack at each loading station for connections, cable routing, etc.

Junction boxes must be provided to connect between the system trunk cable and each ELC-16 control.

SPECIFICATION NOTES:

The ELC-16 system trunk cable is two, 4-conductor shielded twisted cables.

Specifications can change without notice. Check with a Conair representative for the most current information.

TPC052-0108

Specifications: Easy Loading Control (ELC) (continued)

Optional ControlMate™ Pendant

The optional ControlMate pendant is used with either the ELC-M or ELC-16 control modules for increased control functionality. (ratio layering, ratio percentage, unload time, load attempts, blowback pulses, purge and load time, along with enabling/disabling of the ControlMate and its associated loader or receiver.)

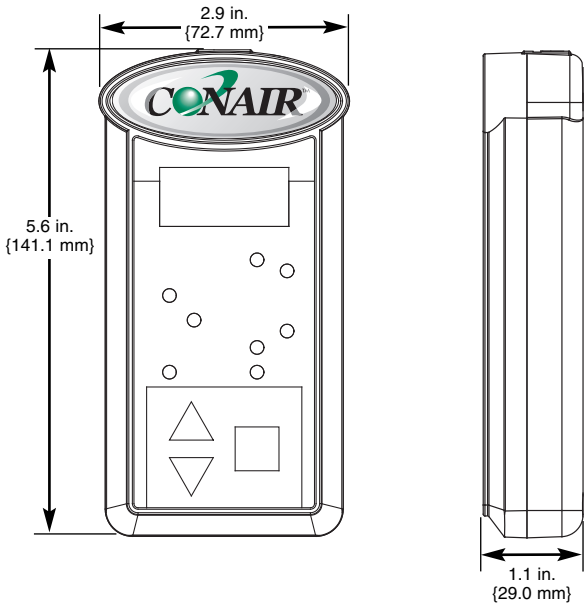

ControlMate™ Pendant Cradle

The ControlMate pendant is provided with a surface mountable docking cradle for quick and easy retrieval. The cradle can be mounted to any vertical or horizontal surface by using M3 flat-head mounting screws.

A cable clip on the control cradle keeps the ControlMate's communication cable up and out of the way for neat installation. It can also be used for a permanent communication cable location when the ControlMate is being used elsewhere.

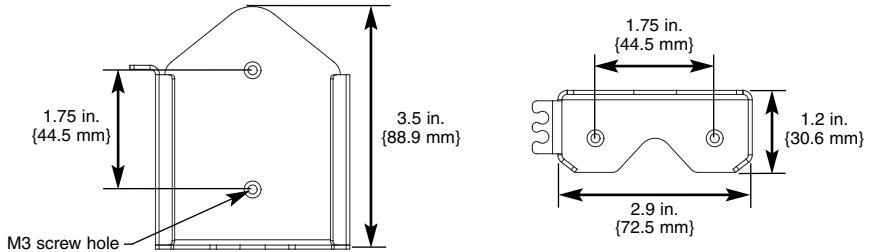

TPC052-0108

Specifications: Easy Loading Control (ELC) (continued)

Pump Control (ELC-16 Only)

The ELC-16 pump control provides power and communications to all the ELC-16 controls within the CAN open system via a 4-conductor trunk cable. The pump control also provides the “start” signal to the vacuum pump used in the conveying process in the ELC-16 system. Cord grips are provided to allow interconnection with the ELC-16 system’s trunk cable, dust collector and idle mode valve connections.

The pump control enclosure is equipped with wall mounting accommodations and can be mounted to a flat surface using the supplied mounting holes. The pump control should be located so access to its switches and viewing of its lights are not obstructed.

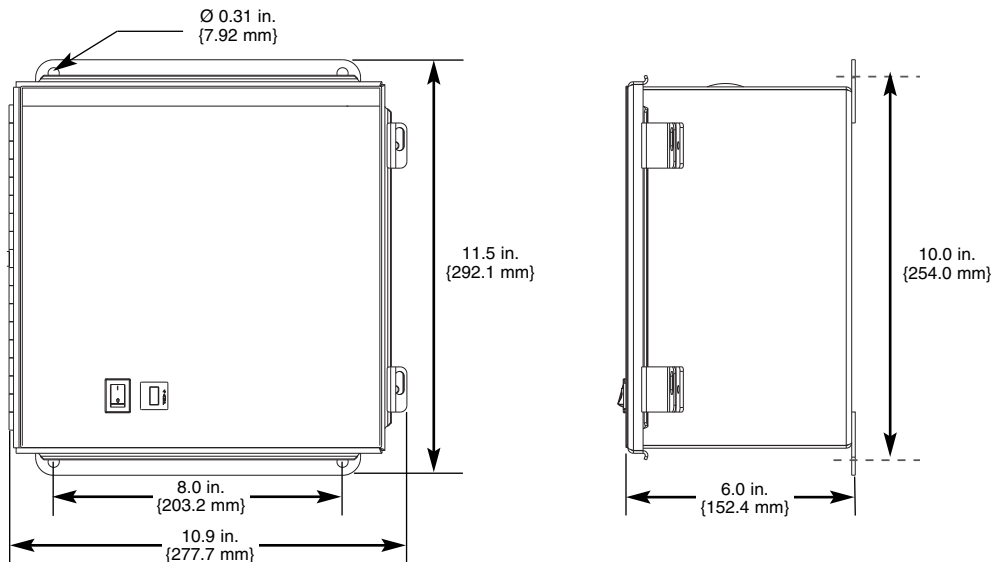

TPC052-0108

Installation

Unpacking the boxes	3-2
Preparing for installation	3-3
Wiring considerations	3-4
Mounting the ELC control	3-5
Connecting main power to the ELC-M control .	3-6
Wiring the ELC-16 pump control	3-7
ELC-16 control junction boxes	3-9
Mounting the ELC-16 control junction boxes.	3-10
Connecting the junction box ground wire . . .	3-10
Wiring the ELC-16 control junction boxes . .	3-11
Connecting the trunk cable termination resistor	3-14
Mounting the ELC ControlMate pendant (optional)	3-17
Connecting the ELC-16 control to the junction box drop cable	3-18
Powering the pump control	3-19
Powering the ELC control	3-20

Unpacking the Boxes

The Easy Loading Control (ELC) comes in one box or will be shipped previously mounted to your loader or receiver. The box could include (depending on the options selected):

- Easy Loading Control - (ELC-M or ELC-16)
- ControlMate™ pendant - optional
- ControlMate™ pendant cradle - optional
- Communication cord (10 or 15 ft. {3.1 or 4.6 m}) - optional
- A loader or receiver - if ordered as a unit
- User Guide

1 Carefully remove the ELC and its components from their shipping box.

2 Remove all packing material, protective paper, tape, and plastic.

3 Carefully inspect all components to make sure no damage occurred during shipping, and that you have all the necessary hardware.

4 Take a moment to record serial numbers and electrical power specifications in the blanks provided on the back of the User Guide's title page. The information will be helpful if you ever need service or parts.

6 You are now ready to begin installation.

Follow the preparation steps on the next page.

Preparing for Installation

The ELC is easy to install if you plan the location of the ELC unit along with its associated loader/receiver to ensure adequate space for access and wiring. The optional ControlMate pendant should also be mounted within easy reach and visibility using its associated cradle.

1 Check individual loader/receiver manuals for proper installation procedures of that equipment.

- Provide a clean, dry, vibration-free environment.** Exposure to wide temperature variations, high ambient temperature, power line fluctuations, caustic fumes or excessive amounts of dust, dirt, vibration, shock and moisture could harm performance and reduce the life of this equipment.
- Provide a grounded source of 115VAC/60Hz, 230VAC/60, 400VAC/50 Hz or 460VAC/60Hz power depending on the ELC model.** See *Description section entitled, Specifications: Easy Loading Control (ELC).*

2 Plan the power/communication cable routes if the ELC-16 model is used.

- Review all wiring guidelines and diagrams** provided in/with this manual and your conveying equipment manuals before beginning installation.
- Keep communication wires away from sources of static electricity.** Static electricity can damage the controls. Communication cables should **not** be installed near the material lines and hoses, which produce large amounts of static electricity when material is conveyed.
- Avoid running cables across power feed lines.** If you must run the cable across power feed lines, run the cable at right angles (90°) to the lines.
- Do not run communication cables along side existing power cable trays.**



WARNING: Voltage hazard

A properly sized conductive ground wire from the incoming power supply must be connected to the chassis ground or P.E. (physical earth) terminal inside the electrical enclosure.

- Connect the ground cable lead from individual ELC-16 junction boxes to a structurally grounded (physical earth) source.**



WARNING: Wires should be routed neatly away from any hot surfaces or areas of mechanical abrasion. Wires must be located away from normal machine maintenance or traffic areas.

Wiring Considerations



WARNING: Improper installation may result in equipment damage or personal injury.

- 1 Disconnect and lock out the main power supply** to equipment in the conveying system before attempting to wire power and communication cables between the ELC control, loader/receivers, junction boxes, pumps, dust collectors and material valves.
- 2 Install all wiring, disconnects and fuses** in accordance with electrical codes in your region. All electrical installations should be done only by qualified electrical technicians.
- 3 Always refer to the wiring diagrams** supplied with your control before making electrical connections. The diagrams show the most accurate electrical component information.
- 4 Protect communication cables from sources of static electricity and electrical noise.**
 - Use shielded cable or run wire through a contiguous metal conduit or wireway. Failure to use a metal shield can expose the controls to static electricity, which can damage electronic components.
 - Do not run communication cables near material lines and hoses, which produce large amounts of static electricity when conveying material.
 - Keep communication cables at least 5 ft. (1.5 m) from electric motors, transformers, rectifiers, arc welders, generators, induction furnaces and sources microwave radiation.
 - Avoid running communication cable across power feed lines. If you must run the cable across power feed lines, run the cable at right angles (90°) to the lines. Keep the cable at least 6 in. {15.2 cm} from AC power lines of less than 20 A; 1 ft. {30.5 cm} from lines of 20A to 100 kVA; and 2 ft. {60.9 cm} from lines of 100 kVA or more.
- 5 Always maintain a safe ground.** Follow the safe grounding procedures in the wiring diagram package. Ground the shielded cable inside the Input/Output enclosure only.
- 6 Do not operate the equipment at power levels other than those specified on the the equipment data plate.**

Mounting the ELC Control

All ELCs are directly mounted to their respective loader or receiver from Conair. Follow the user manual that is supplied with your loader or receiver for proper mounting procedures to your hopper or vessel.



Access Receiver with ELC-16 (optional)



Access Loader with ELC-M (standard)



CAUTION: Controls mounted to the loader/receiver are NOT intended to be used as a handle to lift the loader/receiver or to provide balance assistance to users during maintenance, etc. Doing so could result in serious injury or damage to the equipment.

Connecting Main Power to the ELC-M Control

The ELC-M loading controls are self-contained and operate a single loader. This loader control is **not** used on a CAN open network and is wired to provide its own power to the vacuum motor on top of the loader to receive material. When ordered from Conair the loader's specific conveying functions will be pre-wired to communicate with the ELC-M.



CAUTION: Always disconnect and lock out the main power sources before making electrical connections. Electrical connections should be made only by qualified personnel.

To connect power to the ELC-M and its associated loader:

1 Plug the loader's power cable to the female receptical on the ELC-M.



ELC-M Female Receptical

2 Connect the ELC-M's power cable plug to an appropriate power source.

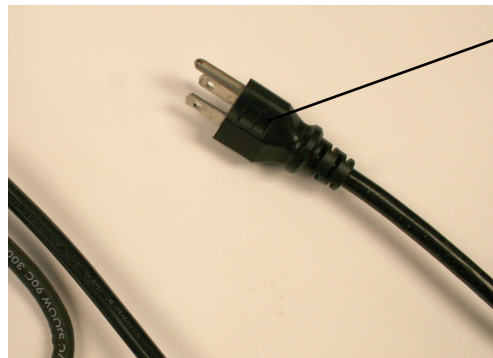

ELC-M Power Cable Plug

Wiring the ELC-16 Pump Control

(ELC-16 Only)



CAUTION: Always disconnect and lock out the main power sources before making electrical connections. Electrical connections should be made only by a qualified electrical technician.

The ELC-16 pump control provides power and communications to all of the ELC-16 controls within the CAN open system via a 4-conductor trunk cable. The pump control also provides the “start” signal to the vacuum pump used in the conveying process in the ELC-16 network. Cord grips are provided to allow interconnection with the ELC-16 system’s trunk cable, dust collector and idle mode valve connections.

The pump control enclosure is equipped with wall mounting accommodations and can be mounted to a flat surface using the supplied mounting holes. The pump control should be located so access to its switches and viewing of its lights are not obstructed. *See Description section entitled, Specifications: Easy Loading Control (ELC), Pump Control.*

Refer to Drawing No. 1076504 or 1076505, depending on your supply voltage, for a full example of the pump control’s wiring. Terminal strips are provided inside the pump control for all connections.



IMPORTANT: Always refer to the wiring diagrams that came with your equipment to locate specific electrical components. Illustrations in the User Guide are intended to be representative only.

Mounting Holes (4)



Wiring the ELC-16 Pump Control

(ELC-16 Only) (continued)



CAUTION: Always disconnect and lock out the main power sources before making electrical connections. Electrical connections should be made only by a qualified electrical technician.

After mounting the pump control, access to its internal wiring components is required for power connections, ELC-16 trunk cable, etc.

To open the pump control cabinet:

- 1 Loosen the two (2) retaining screws** that secure the closure brackets on the right-side of the pump control cabinet with an appropriately sized screwdriver.

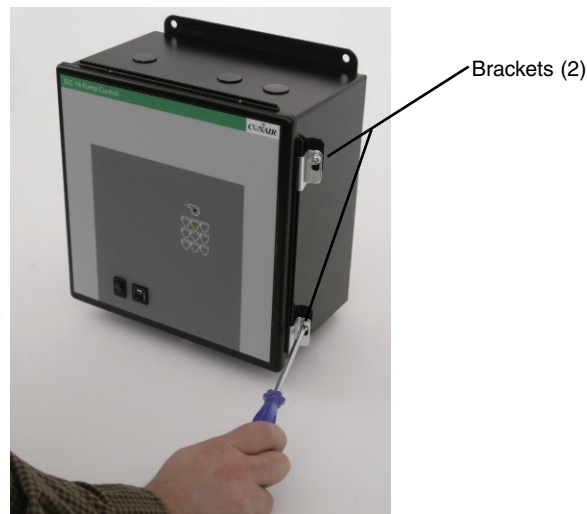

- 2 Swing open the pump control cabinet access door.**

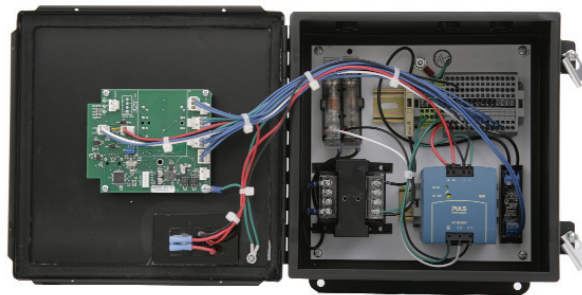

ELC-16 Control Junction Boxes

(ELC-16 Only)

Loading controls on the ELC-16 system are supplied by a trunk cable. The cable has two shielded twisted pairs of wires. One pair supplies power and the second pair is used for CAN communications. The trunk cable starts at the pump control located near the vacuum pump and ends at the ELC-16 control furthest from the pump control.

Connections for each control will require a junction box (for example, a ten (10) receiver system would need ten (10) ELC-16 controls connected to ten (10) junction boxes which are then connected to the ELC-16 trunk cable). Each individual junction box provides a 3-way “T” connection at each receiver, along with a pre-wired ground line to connect the ELC-16 and its receiver to a structural ground. At the bottom of the junction box, a 10, 15 or 20 ft. {3.1 4.6 or 6.1 m} drop cable is connected. This drop cable is fitted with a quick-disconnect circular connector that interfaces directly with the control itself. The junction box end of the drop cable is pre-connected and can be shortened as needed for neat installation.



CAUTION: Always disconnect and lock out the main power sources before making electrical connections. Electrical connections should be made only by a qualified electrical technician.

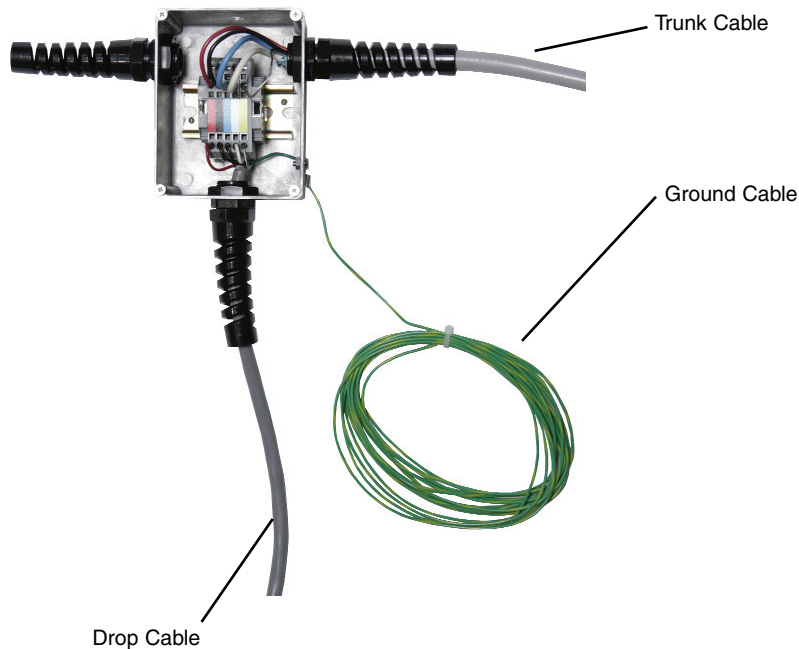

Mounting the ELC-16 Control Junction Boxes (ELC-16 Only)

ELC-16 “T” junction boxes can be top mounted using the pre-drilled 0.375 inch {9.525 mm} hole located at the top of the junction box.

Use of a pre-determined length of All-Thread steel rods are recommended to accurately mount the junction box in the desired location.

Junction boxes can also be flush mounted to a wall or other flat surface by drilling through the back of the box and anchoring it with appropriate hardware.

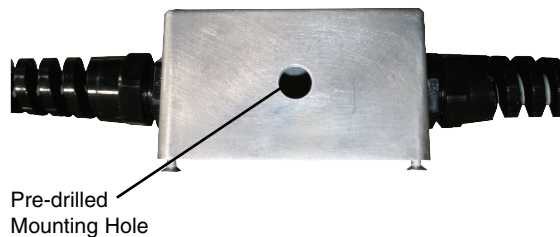

Connecting the Junction Box Ground Wire (ELC-16 Only)



CAUTION: Always disconnect and lock out the main power sources before making electrical connections. Electrical connections should be made only by a qualified electrical technician.



WARNING: Voltage hazard

A properly sized conductive ground wire from the incoming power supply must be connected to the chassis ground or P.E. (physical earth) terminal inside the electrical enclosure.

Each junction box includes a pre-wired ground connection that is connected directly to the internal terminal block. It is recommended to connect the ground wire to a structural ground to eliminate any static electricity that may occur from nearby conveying lines.

To connect the junction box ground wire:

- 1** Connect the green ground wire to a structural ground, typically a steel beam or similar using an appropriate screw or bolt.

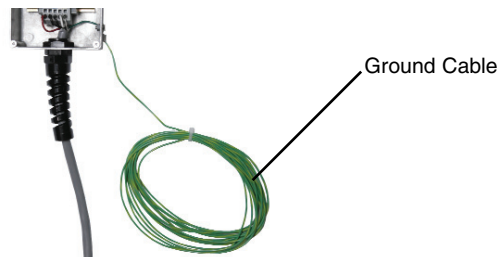

Wiring the ELC-16 Control Junction Boxes (ELC-16 Only)

Carefully lay out the path of the 4-conductor trunk cable from the pump control to each junction box and its associated receiver. *See Installation section entitled, Wiring the ELC-16 Pump Control.* If you must run the cable across power feed lines, run the cable at right angles (90°) to the lines. This will minimize the amount of noise on the ELC-16 CAN open network.

The ELC-16 system utilizes low voltage signals (24 VDC) to communicate between ELC loading controls and the pump control.

 **NOTE:** Install the ELC-16 with wiring as appropriate for your local and industrial electrical codes.

To connect individual junction boxes:

- 1 Mount the junction box in the desired location.** Ensure proper wiring support between junction boxes.
- 2 Remove the junction box cover** by unscrewing the four (4) retaining screws that secure the cover with an appropriately sized screwdriver. (If not previously remove during junction box mounting.)

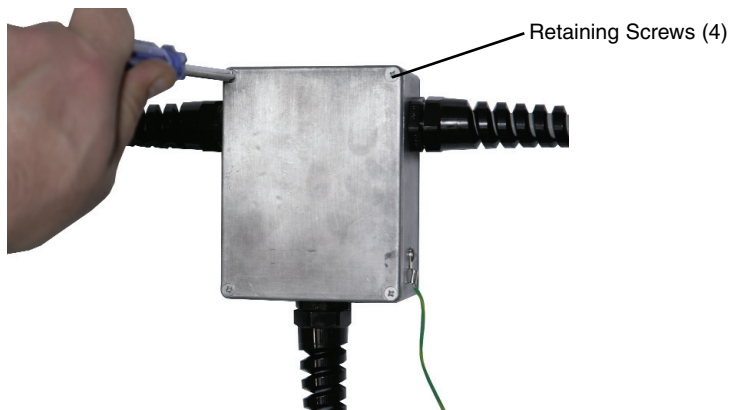

(continued)



CAUTION: Always disconnect and lock out the main power sources before making electrical connections. Electrical connections should be made only by a qualified electrical technician.

Wiring the ELC-16 Control Junction Boxes (ELC-16 Only) (continued)



CAUTION: Always disconnect and lock out the main power sources before making electrical connections. Electrical connections should be made only by a qualified electrical technician.

- 3** Unscrew the left or right (depending on trunk cable routing) black strain relief counterclockwise. Thread the trunk cable through the detached section of the strain relief.

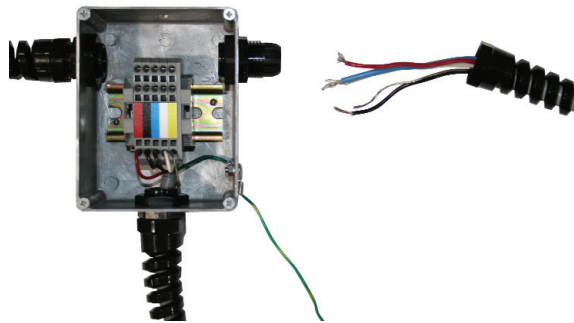

- 4** Thread the trunk cable through into the junction box, ensuring not to insert the cable too far into the junction box. Reattach and tighten the removed strain relief.

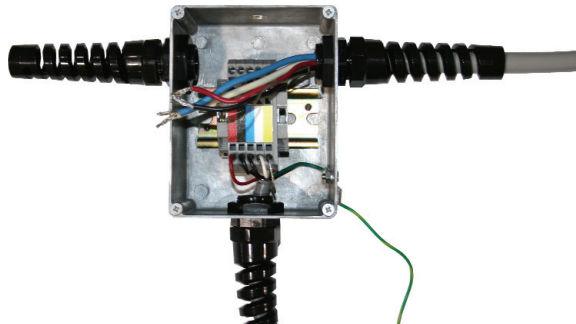

(continued)

Wiring the ELC-16 Control Junction Boxes (ELC-16 Only) (continued)

- 5** Connect the individual trunk cables to the terminal block using an appropriately sized screwdriver or similar. Each terminal block within the junction box is color coded to correspond to the supplied trunk cable wire. Except the trunk cable ground wire which will be connected to the yellow terminal. There are five (5) terminals for the trunk cable. Trunk cables entering from the right will need to be inserted into the bottom row of terminals. Trunk cables entering from the left will need to be inserted into the top row of terminals.



CAUTION: Always disconnect and lock out the main power sources before making electrical connections. Electrical connections should be made only by a qualified electrical technician.

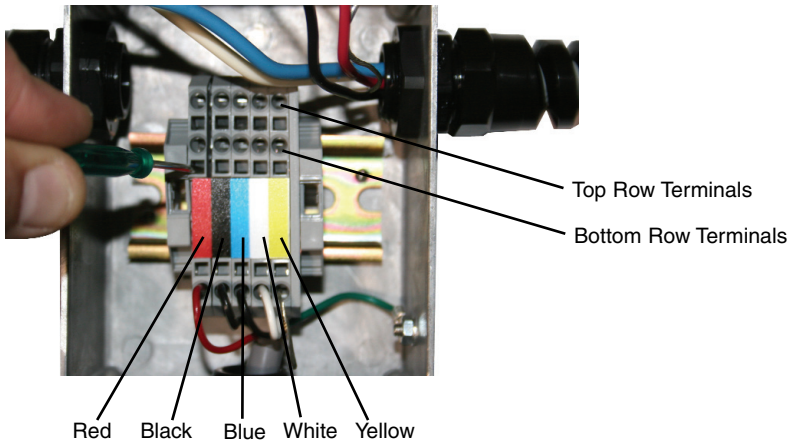

- 6** Replace the junction box cover, tighten retaining screws.
- 7** Repeat above steps for all junction boxes within your CAN open network.

Connecting the Trunk Cable Termination Resistor (ELC-16 Only)



CAUTION: Always disconnect and lock out the main power sources before making electrical connections. Electrical connections should be made only by a qualified electrical technician.

While laying out the trunk cable to each individual junction box, you will need to terminate the trunk cable line. Depending on your individual layout, the trunk cable may terminate from either the left or right side of the junction box. A trunk cable termination resistor is used to end the CAN open network's communications when there are 16 or less junction boxes in use.

To terminate the trunk cable using the termination resistor:

- 1 Remove the junction box cover** by unscrewing the four (4) retaining screws that secure the cover with an appropriately sized screwdriver. (If not previously removed during junction box mounting.)

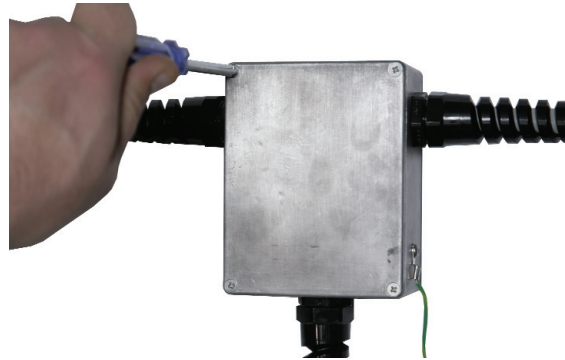

- 2 Unscrew and remove the left or right (depending on trunk cable routing) black strain relief counterclockwise** and remove the inner mount fitting from inside the junction box.

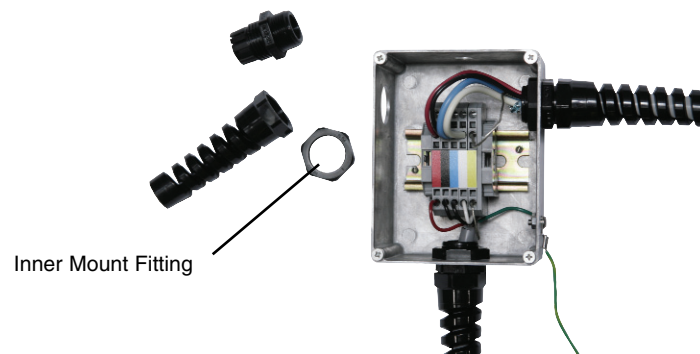

Connecting the Trunk Cable Termination Resistor (ELC-16 Only)

(continued)

- 3 Thread the termination resistor's two (2) wires through the knock out hole on the side of the junction box.

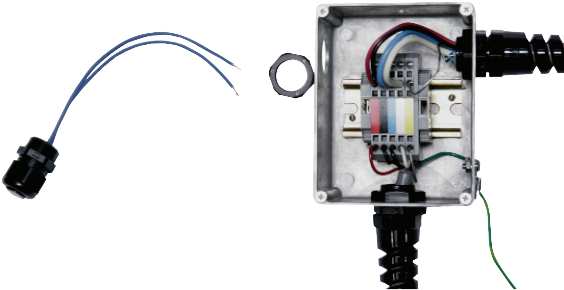

- 4 Hold the termination resistor in place while screwing on the inner mount fitting, ensuring to thread the two (2) resistor wires through the inner mount fitting before tightening.

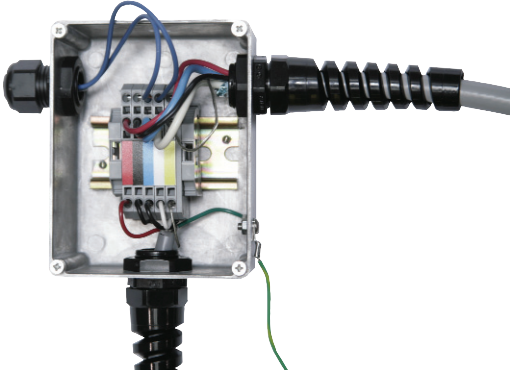

CAUTION: Always disconnect and lock out the main power sources before making electrical connections. Electrical connections should be made only by a qualified electrical technician.

Connecting the Trunk Cable Termination Resistor (ELC-16 Only)

(continued)



CAUTION: Always disconnect and lock out the main power sources before making electrical connections. Electrical connections should be made only by a qualified electrical technician.

- 5** Connect the termination resistor wiring to only the **BLUE** and **WHITE** terminals, by using an appropriately sized screwdriver or similar. See *Installation section entitled, Wiring the ELC-16 Control Junction Boxes*. Depending on your cable routing, the resistor may need to be wired at the top row of terminals for resistors that are placed on the left-side of the junction box or at the bottom row for resistors that are placed on the right-side of the junction box.

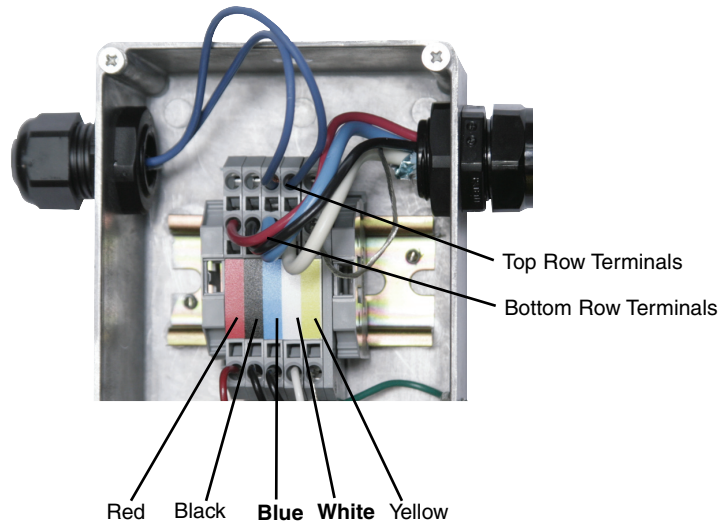

(Left-side termination resistor connection)

Mounting the ELC ControlMate™ Pendant (optional)

The optional ControlMate pendant can be remotely mounted with a surface mountable docking cradle for quick and easy retrieval. Be sure to locate the control within the length of the supplied remote control cabling (10 ft. {3.05 m}) and route the cable away from hot surfaces or moving parts.

A cable clip on the control cradle keeps the ControlMate's communication cable up and out of the way for neat installation. It can also be used for a permanent communication cable location when the ControlMate is being used elsewhere.

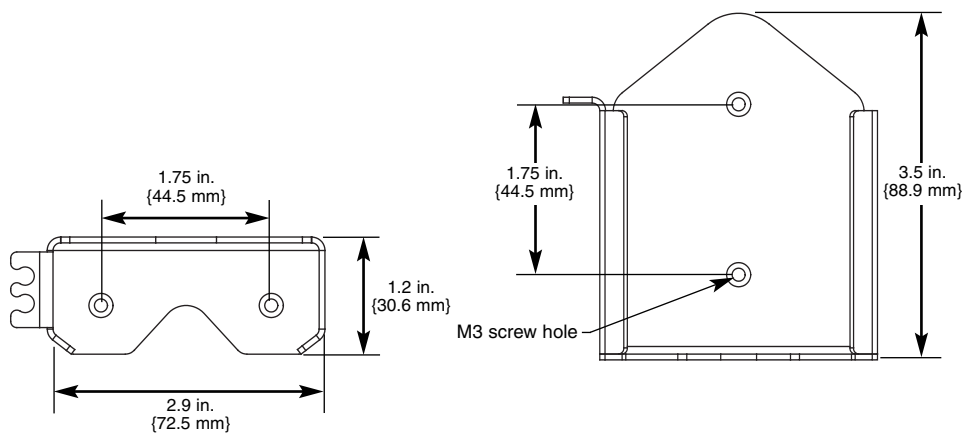

Connecting the ELC-16 Control to the Junction Box Drop Cable

The ELC-16 must be connected to the junction box drop cable via a 5-pin connector to receive power and communications.

To connect the 5-pin connector from the junction box drop cable to the ELC-16 control:

- 1 Push the drop cable connector into the 5-pin receptacle on the ELC-16.** Turn the connector fitting clockwise, hand-tighten.



Powering the Pump Control

The pump control has built-in toggle switches for both main power and a 4 amp circuit breaker located at the bottom right of the front panel. Conair recommends powering the pump control first before powering the ELC-16 controls that are on the CAN open network. This is to ensure that power can be detected on the system truck cable and unwanted activation of ELC-16's and their respected receivers is avoided.

To turn on the pump control:

- 1 Push the toggle switch to the “On” position.** The pump control switch will illuminate green.

NOTE: When there is demand for material on the CAN open network, the pump control's Demand LED will illuminate. If there is no demand on the CAN open network, the Demand LED will not be illuminated.

NOTE: When the vacuum pump is running the Loading LED will be illuminated. If the vacuum pump is not running the Loading LED will not be illuminated.

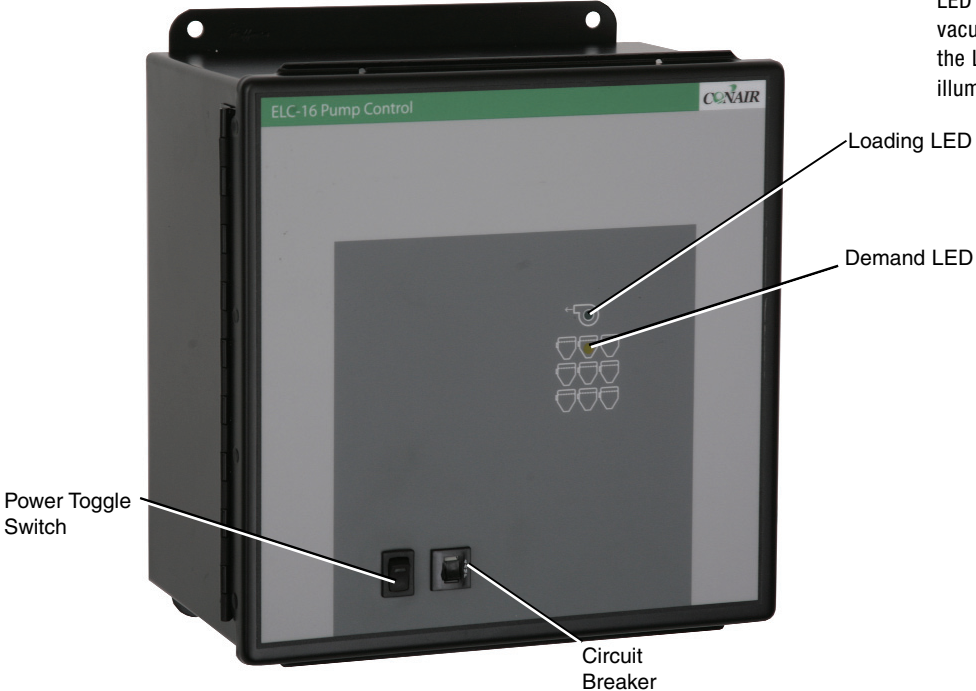

To reset the pump control circuit breaker:

- 1 Push the circuit breaker toggle switch,** that is located to the right of the power toggle switch.

Powering the ELC Control

The ELC-M and ELC-16 controls have built-in power toggle switches located on the right-side of their enclosures. Each control will need to be turned on to start a loading cycle.

The ELC-16 control will have an additional toggle switch located to the right of the main power toggle switch. This toggle switch is the individual 4 amp circuit breaker for the ELC-16 control. The ELC-M's power switch also acts as a circuit breaker.

To turn on and activate either ELC control:

- 1 Push the toggle switch to the “On” or “Reset” position.** The ELC-16 switch will illuminate green and the ELC-M switch will illuminate amber.

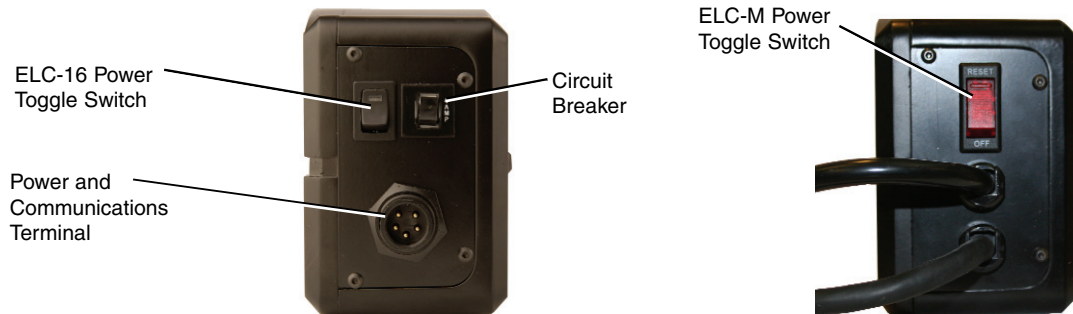

To reset the ELC-16 circuit breaker:

- 1 Push the circuit breaker toggle switch,** that is located to the right of the power toggle switch.



Operation

SECTION

4

Easy Loading Control: Control panel layout . . .	4-2
ELC loading control operation	4-3
Basic operation	4-3
Load time adjustment	4-4
Alarm acknowledgement	4-5
Using blowback	4-6
ControlMate pendant: LED descriptions	4-8
ControlMate pendant operation	4-9
Connecting the ControlMate pendant . . .	4-10
Enabling/disabling the ControlMate pendant	4-11
Hopper loading with positive discharge option	4-11
Adjusting unload time	4-12
Adjusting the number of load attempts before an alarm	4-13
Adjusting ratio percentage	4-14
Adjusting ratio layers	4-15
Using purge operation	4-16
Adjusting load time	4-18
Using blowback	4-19
User level 2 settings for the ControlMate pendant	4-21

Operation
4

Easy Loading Control: Control Panel Layout

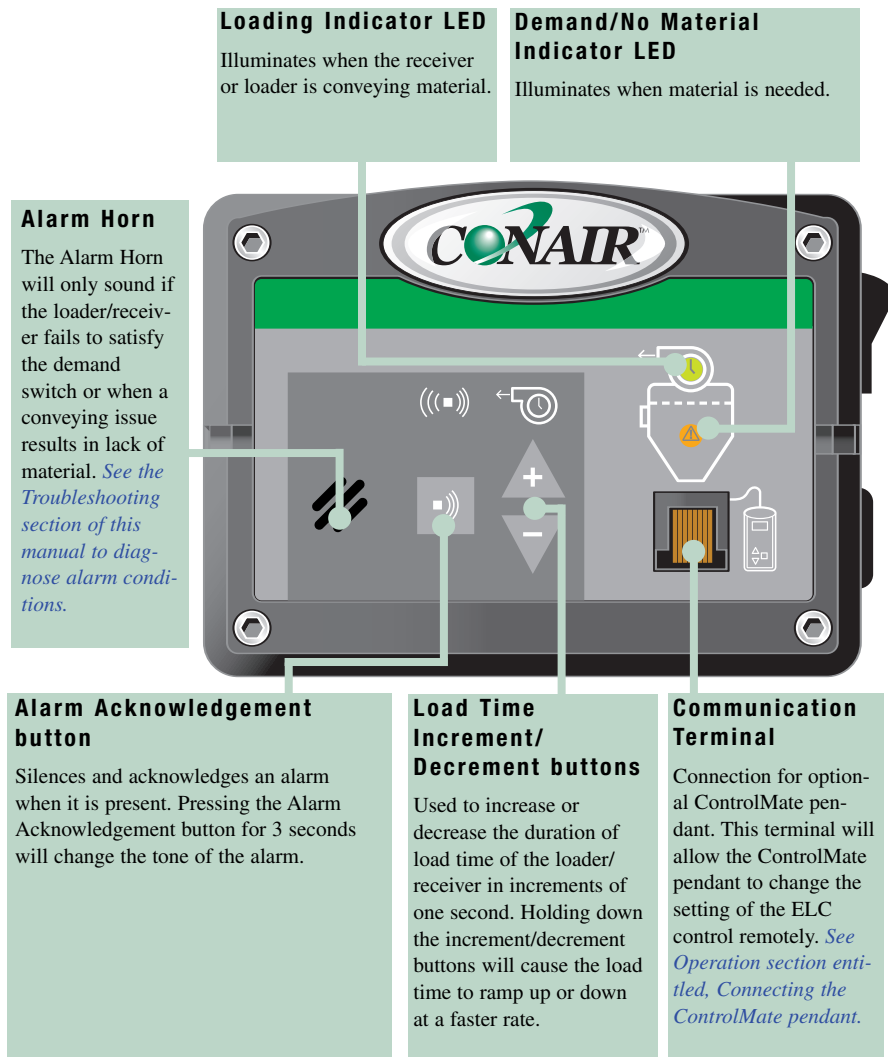

ELC Loading Control Operation

How it Works

The start of a loading sequence is triggered by the loader/receiver's demand switch. The demand switch will signal the ELC-M to energize its loader's vacuum motor pump to start conveying material to its hopper or surge bin.

When the ELC-16 is used, the loading sequence is started the same as the ELC-M. However, instead of signaling a vacuum motor located on the actual loader to start the loading process, the control's demand for material will be added to the pump control's queue. On its turn the vacuum pump will convey material to the individual receiver.

On a loader/receiver, there is a material flapper integrated into the gravity discharge valve located at the bottom of the loader/receiver that will trigger the demand switch. During operation, the flapper will be held shut by its own counterweight which will signal the ELC that there is a demand for material and will start a load cycle. Standard demand switches are a "reed" type that magnetically interact with a small magnet located on the flapper weldment. As the magnet approaches the switch it will close providing a demand signal.

After discharging material into the vessel below, the cycle may repeat or the discharge flapper may become lodged open with material. If the flapper closes, the cycle will repeat. If the flapper is held open by the material, this is an indication that there is no need for another load cycle and the loader/receiver will then wait until the material level falls and the flapper closes again causing the flapper to engage the reed switch that will signal for another load cycle.

 **NOTE:** If your loader/receiver has a capacitance sensor, refer to the loader/receiver's manual for adjustment procedures.

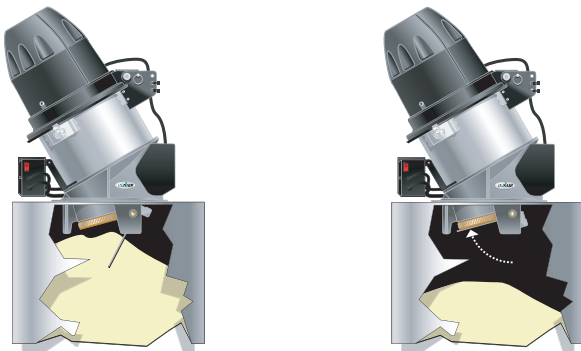

ELC Loading Control Operation

(continued)

Load Time Adjustment

When using single material hopper loading only the load time can be changed. *See your loader/receiver manual for recommended load time duration settings.*

 **NOTE:** The ELC loading control's default load time is loader/receiver model dependent and will be set by Conair.

Load time settings can be changed by using the (+) or (-) buttons located on the ELC. The control load time should be adequate enough to just fill the loader/receiver. Using too long of a load time will cause unnecessary material to clog the conveying inlet tubes to the loader or receiver.

 **NOTE:** The use of the (+) and (-) buttons represents the addition or subtraction of load time in one second increments. Holding down the (+) or (-) buttons will cause the load time to ramp up or down at a faster rate.



Alarm Acknowledgement — Load Time Adjustment

To adjust Load Time with standard controls:

- 1 Use the (+) and (-) buttons to the right of the Alarm Acknowledgment button to increase or decrease the amount of load time, in one second increments.**
- 2 Adjust the load time through trial and error.** Several adjustments may be needed to optimize your particular conveying needs.

ELC Loading Control Operation

(continued)

Alarm Acknowledgement

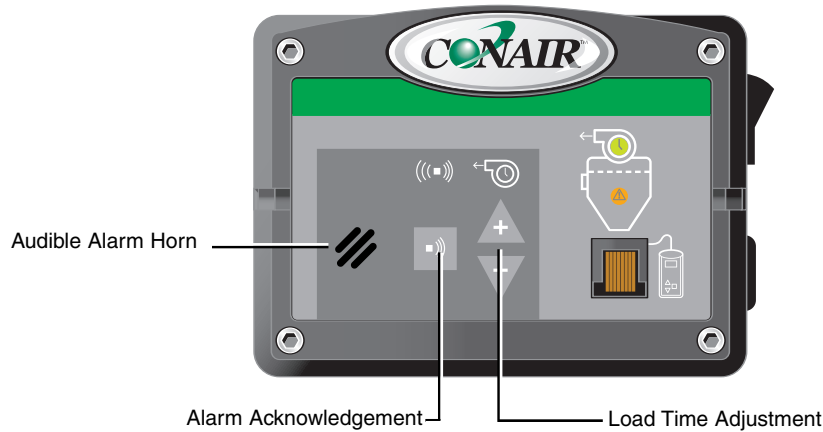

To silence the audible alarm horn on the standard ELC controller:

- 1 Press the Alarm Acknowledge button located to the left of the Load Time Adjustment (+) or (-) buttons.** Failure to correct the cause of the alarm will result in the the alarm reoccurring until the problem is corrected. *See the Troubleshooting section to diagnose the possible cause of an alarm.*

 **NOTE:** Silencing of any alarm will need to be done from the ELC control. Alarm acknowledgements can not be be made from the ControlMate pendant.

ELC Loading Control Operation

(continued)



CAUTION: Always disconnect and lock out the main power sources before accessing the ELC's internal connections. Electrical connections should be made only by qualified personnel.

Using Blowback

Loaders/receivers equipped with blowback functionality use air pulses to clean their internal filter. Internal jumpers on the ELC's control board are set to activate three blowback pulses as standard. These jumpers can be configured to active one to seven pulses, by removing or relocating the jumpers. However, when blowback is accessed through the optional ControlMate pendant it is possible to override the internal setting of the blowback jumpers in favor of the amount set using the pendant.

To manually adjust the blowback setting of the ELC:

- 1 Remove the four (4) screws that secure the ELC's front cover with an appropriately sized Allen Wrench.**

Allen Wrench Screws (4)



(continued)

ELC Loading Control Operation

(continued)

Using Blowback

2 Remove the ELC control cover and place it along side the control box.

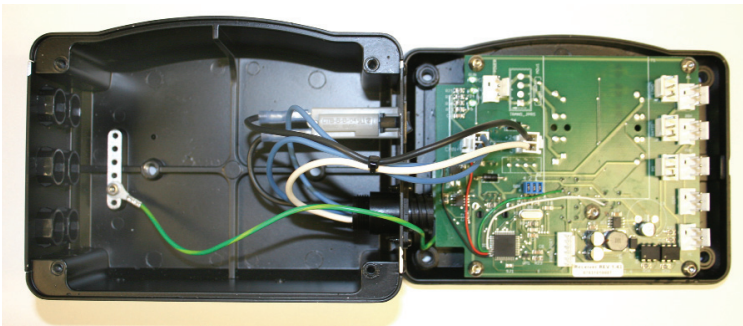

CAUTION: Always disconnect and lock out the main power sources before accessing the ELC's internal connections. Electrical connections should be made only by qualified personnel.

3 Locate the three (3) blue jumpers on the ELC control board.

Jumpers (3)

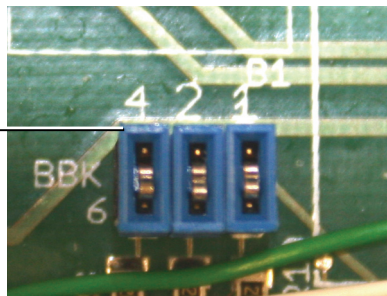

4 Remove corresponding jumpers to equal the amount of blowback pulses to be used. Each jumper adds or removes a number of blowback pulses.

The range of blowback is one to seven pulses, depending on the configuration and amount of jumpers used. For example, the jumper switches in the picture above are labeled with the number of blowback pulses they represent (4, 2, 1).

5 Reassemble the ELC control module by following steps 1-2 in reverse order.

ControlMate™ Pendant: LED Descriptions

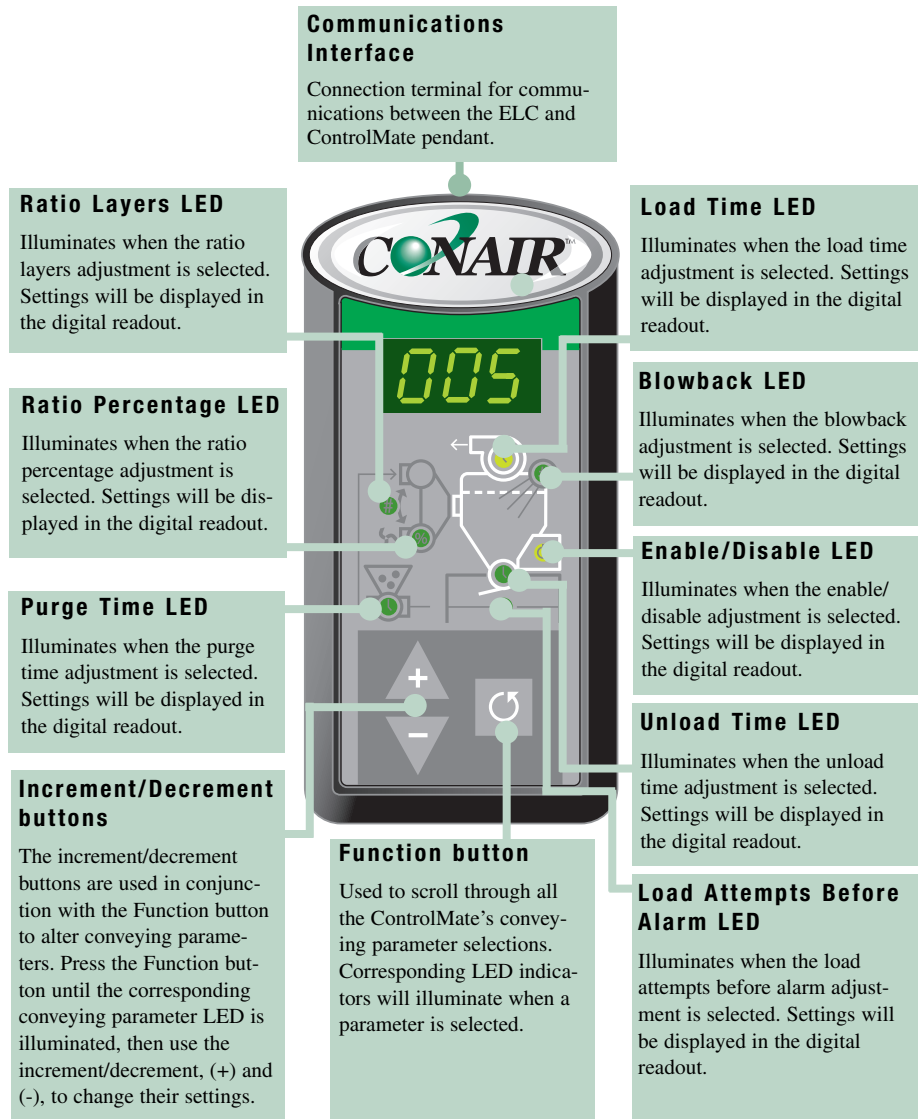

NOTE: The functions described above can only be altered with the addition of the optional ControlMate pendant with the exception of Load Time, which can be changed using the ELC control interface. *See the Operation section entitled, ELC Loading Control Operation, Load Time Adjustment.*

ControlMate™ Pendant Operation

If the optional ControlMate was purchased along with the Easy Loading Control (ELC) it will offer more conveying abilities such as: blowback pulses, ratio loading percentage, ratio layering, number of loading attempts before an alarm, purge time and unloading time. The ControlMate can be used interchangeably between each receiver or loader. The changes that are made will be saved within the ELC module.

The following chart shows what parameters and capabilities are available at each User Level and the ranges of each setting that can be changed with the optional ControlMate pendant.

Parameters are listed in the order that they appear when the Function button is pressed and will correspond to a LED indicator that will illuminate when adjustments are made. User Level 2 parameters will also be in the order that they appear, but will not have a corresponding LED. Only a three-digit number will appear on the ControlMate's digital display. *See Operation section entitled, User Level 2 Settings for the ControlMate Pendant.*



Description	Range	Default	User Level
On/Off	0-1	1	1
Unload time	3-120 sec.	15	1
Load attempts before alarm	0-50 counts	3	1
Ratio layers*	A, 1-5	A = automatic	1
Ratio percentage*	0 or 5-100%	0	1
Purge time*	0-120 sec	0	1
Load time	3-120 sec	15	1
Blowback pulses*	0-10 counts	3	1

User level 2 is accessed by holding the Function button down for five seconds.

Description	Range	Default	User Level
Priority demand	0-1	0	2
Demand sensor logic	0-1	1	2
Fill sensor logic	0-1	1	2
Fill sensor present	0-1	0	2
Load and hold†	0-1	0	2
Purge/APV option installed	0-1, 2	0	2
Ratio option installed	0-1	0	2
Blowback option installed	0-1	0	2

 **NOTE:** 0 = "off" and 1 = Purge valve "on" for the settings in User Level 2. However for the purge/APV option installed parameter, 2 = APV.

APPLICATION NOTES:
* Only visible when activated by altering the setting in User Level 2
† User must have a positive discharge loader or receiver to use this function, which can be activated through altering this setting in User Level 2.

ControlMate™ Pendant Operation

(continued)

Connecting the ControlMate™ Pendant

 **NOTE:** If the ControlMate is deactivated the loader/receiver will not function until it is enabled, however, if the ControlMate pendant is not available, cycle the standard ELC control module's power to enable the loader/receiver.

 **NOTE:** Power will remain active to both the ControlMate pendant and the ELC control module, when they are disabled. This function only disables the loader/receiver.

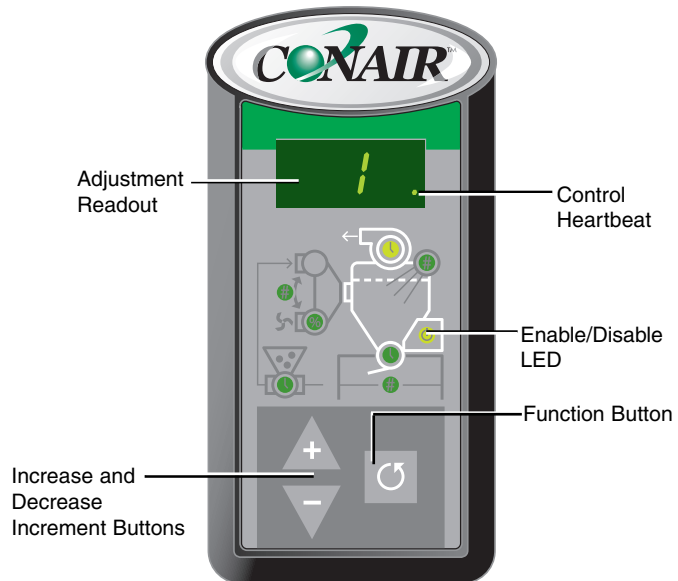

 **NOTE:** The ControlMate loading control's default load time is loader/receiver model dependent and will be set by Conair.

The ControlMate Pendant automatically shows an enable screen when it is initially connected to the ELC control module.

To connect the ControlMate to the ELC module:

- 1 Plug the communication cable into the terminal port** at the top of the ControlMate pendant.
- 2 Plug the communication cable into the terminal port on the ELC module.** The ControlMate pendant will illuminate showing the default Power-on readout and the control heartbeat will pulse to show that it is communicating with the ELC and pump control.

ControlMate™ Pendant Operation

(continued)

Enabling/Disabling the ControlMate Pendant

To deactivate the ControlMate along with the loader/receiver:

- 1 Press the Function Button** until the Enable/Disable LED is illuminated.
- 2 Adjust the Enable/Disable setting by using the (+) and (-) buttons to the left of the function button to activate or deactivate the ControlMate pendant and the ELC's loader/receiver.** Pressing the (+) button will activate the ControlMate Pendant and a "1" will be displayed in the Adjustment Readout, pressing the (-) button will deactivate the pendant and a "0" will be displayed.

 **NOTE:** Activating and altering this setting is possible only through the optional ControlMate pendant. *See Operation Section entitled, ControlMate Pendant Operation.*

Hopper Loading with Positive Discharge Option - How it Works

Loaders/receivers equipped with positive discharge valves operate exactly as other loaders/receivers, however instead of having a simple gravity discharge flapper valve, its valve is "driven" open by an air cylinder linked to its flapper. The time of the discharge valve open cycle is controlled by the "Unload Time" setting adjustable only with the ControlMate pendant.

 **NOTE:** When using the Load/Hold function of the ControlMate pendant you **must** use a positive discharge valve.

Positive discharge valves require remote demand sensors which sense the level of material within a hopper. A rotary switch can be used that has a motor driven paddle, that when stopped by material, indicates a full hopper. However, when the paddle is able to move freely, it signals the loader/receiver that there is a demand for material and signals the controller to load. Rotary switches are equipped with long shafts to allow the paddle to be located far enough below the loader/receiver to prevent material interference when the positive discharge valve is either opened or closed.

 **NOTE:** To adjust the duration of unload time when using a positive discharge hopper, *see Operation section entitled, ControlMate Pendant Operation, Adjusting Unload Time.*

The primary use of positive discharge loading is for when using hoppers that may contain pressurized air (high CFM drying hoppers) or crystallizers which may restrict the free motion of gravity discharge flappers.

ControlMate™ Pendant Operation

(continued)

Adjusting Unload Time

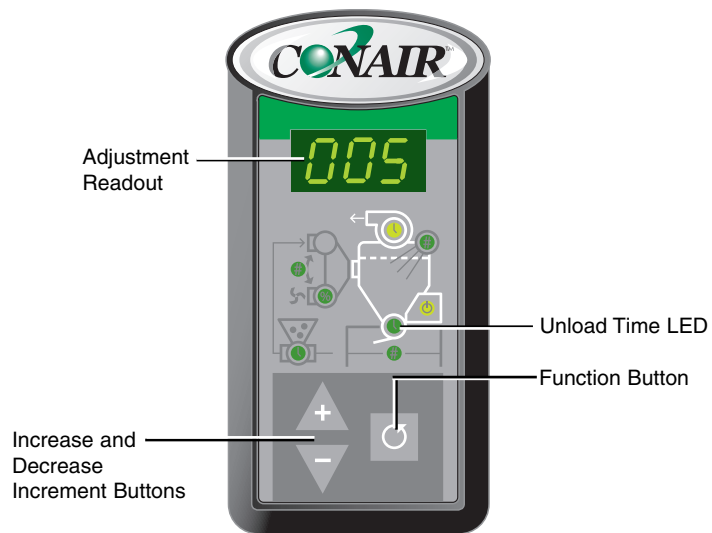

 **NOTE:** Activating and altering this setting is possible only through the optional ControlMate pendant. *See Operation Section entitled, ControlMate Pendant Operation.*

IMPORTANT: Any adjustments made with the ControlMate pendant will not take effect until the loader/receiver starts a new loading cycle.

To adjust the duration of Unload Time:

- 1 Press the Function Button** until the Unload Time LED is illuminated.
- 2 Use the (+) and (-) buttons to the left of the Function button to increase or decrease the unload time duration.** Holding down the (+) or (-) buttons will cause the number to ramp up or down at a faster rate. (The Unload Time range is 3 - 120 seconds) Changes will be displayed in the ControlMate's three-digit adjustment readout display.
- 3 The control will automatically return to its default Power-on screen** after 30 seconds.

ControlMate™ Pendant Operation

(continued)

Adjusting the Number of Load Attempts Before an Alarm

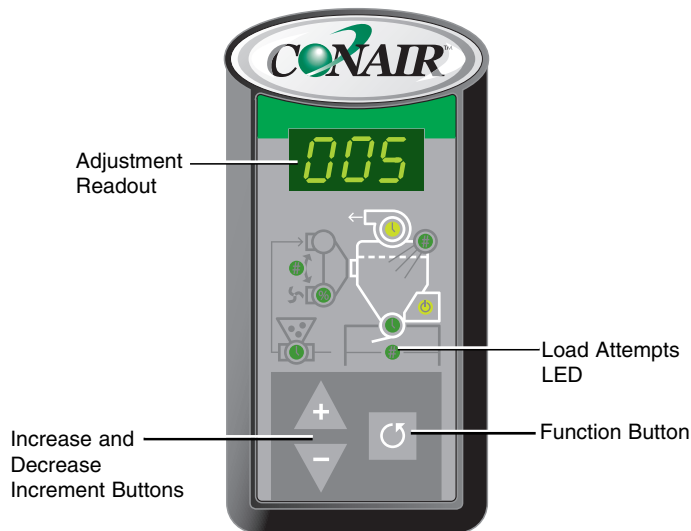

On initial start-up and fill-up of your vessel, the Load Attempts setting will be ignored. Only after the initial fill-up will the Load Attempts setting be used by the control. However, if you are using the loader/receiver to convey regrind from a granulator, setting the Load Attempts to “0” will allow unlimited load attempts to avoid nuisance alarms.

To adjust the number of Load Attempts:

- 1 Press the Function Button** until the Load Attempts LED is illuminated.
- 2 Use the (+) and (-) buttons to the left of the Function button to increase or decrease the amount of Load Attempts.** Holding down the (+) or (-) buttons will cause the number to ramp up or down at a faster rate. (The range is 0 - 50 attempts) Changes will be displayed in the ControlMate’s three-digit adjustment readout display.
- 3 The control will automatically return to its default Power-on screen** after 30 seconds.

 **NOTE:** Activating and altering this setting is possible only through the optional ControlMate pendant. *See Operation Section entitled, ControlMate Pendant Operation.*

ControlMate™ Pendant Operation

(continued)

Adjusting Ratio Percentage

 **NOTE:** Activating and altering this setting is possible only through the optional ControlMate pendant. *See Operation Section entitled, ControlMate Pendant Operation.*

Ratio percentage and ratio layering parameters will need to be altered when operation of a ratio valve is required.

Ratio Percentage is a percentage of load time. For example, If your loader or receiver has a 20 second load time and your ratio percentage is set at 25% the regrind load time will be 5 seconds of regrind material and 15 seconds of virgin material.

 **NOTE:** Adjustments to the ELC-16 controller will need to be done individually for each receiver.

 **NOTE:** Careful examination of your material's unique flow characteristics and conveying distances will aid in adjusting for proper ratio percentage settings.

 **NOTE:** The ratio setting is altered using percentage amounts of total load time.

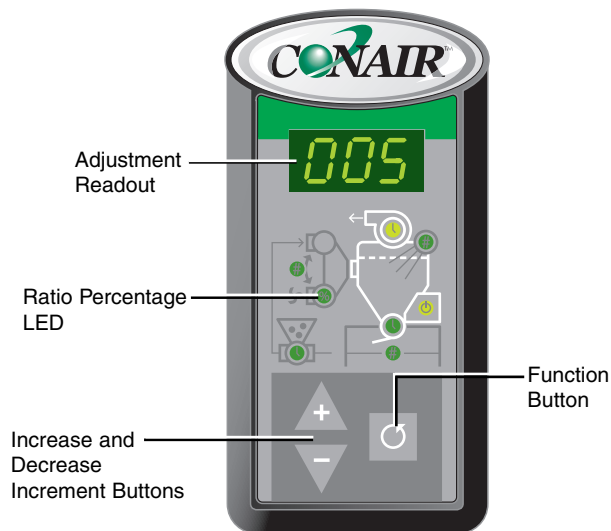

To adjust Ratio Percentage:

- 1 Press the Function button** until the Ratio Percentage LED is lit.
- 2 Use the (+) and (-) buttons to the left of the Function button to increase or decrease the ratio percentage.** Holding down the (+) or (-) buttons will cause the number to ramp up or down at a faster rate. (The percentage range is 0 or 5 - 100%) Changes will be displayed in the ControlMate's three-digit adjustment readout display.
- 3 The control will automatically return to its default Power-on screen** after 30 seconds.

ControlMate™ Pendant Operation

(continued)

Adjusting Ratio Layers

The Ratio Layering setting allows the ELC to control the number of alternating layers of virgin and regrind material. To make ratio loading as simple as possible the ControlMate pendant has a setting “A” to automatically calculate the maximum number of possible layers based on the ratio percentage and total load time. Using the automatic layer number selection is recommended unless you require special conveying parameters, in those cases a number of 1 to 5 layers is recommended.

 **NOTE:** Activating and altering this setting is possible only through the optional ControlMate pendant. *See Operation Section entitled, ControlMate Pendant Operation.*

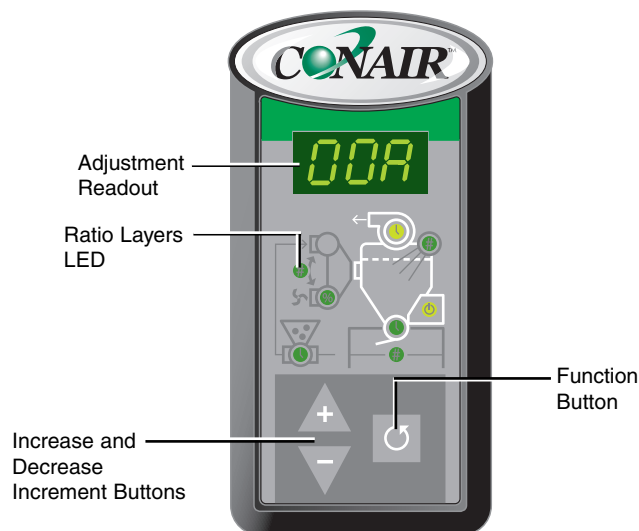

To adjust the number of Ratio Layers:

- 1 Press the Function button** until the Ratio Layers LED is lit.
- 2 Use the (+) and (-) buttons to the left of the Function button to increase or decrease the number of layers.** Holding down the (+) or (-) buttons will cause the number to ramp up or down at a faster rate. (The range is 1 - 5 or A for automatic layering) Changes will be displayed in the ControlMate's three-digit adjustment readout display.
- 3 The control will automatically return to its default Power-on screen** after 30 seconds.

ControlMate™ Pendant Operation

(continued)

Using Purge Operation

 **NOTE:** Activating and altering this setting is possible only through the optional ControlMate pendant. See *Operation Section entitled, ControlMate Pendant Operation.*

 **NOTE:** Purge time setup varies depending on the model of purge valve you are using. Reference your purge valve manual for proper setup.

The first stages of the loading cycle for either a loader or receiver using the purge function will operate exactly as a normal load cycle. Only after the end of the user set load time will the material valve (purge or APV) be signaled by the ELC to change state and stop the flow of material into the material line. The material line will then be purged with air for the amount of time set by the user for purge time (0-120 seconds).

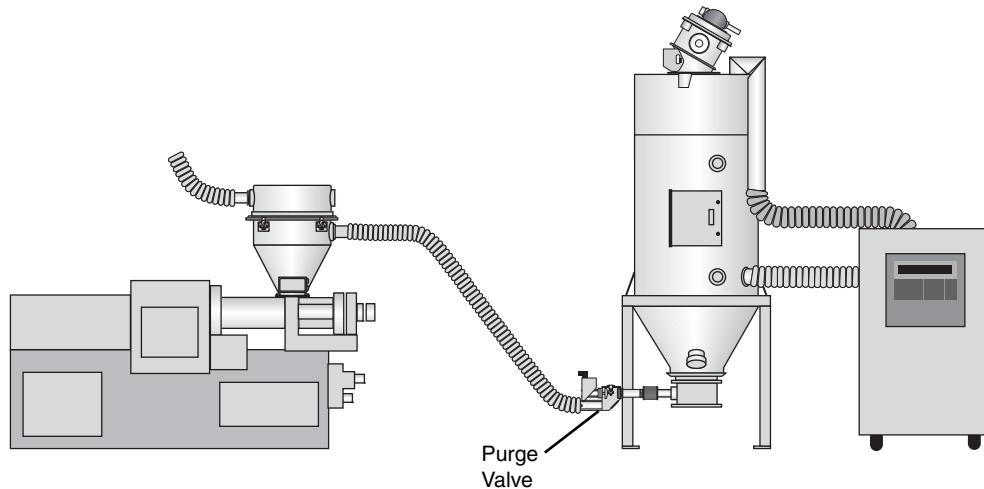

Purge valve example shown

(continued)

ControlMate™ Pendant Operation

(continued)

Using Purge Operation (continued)

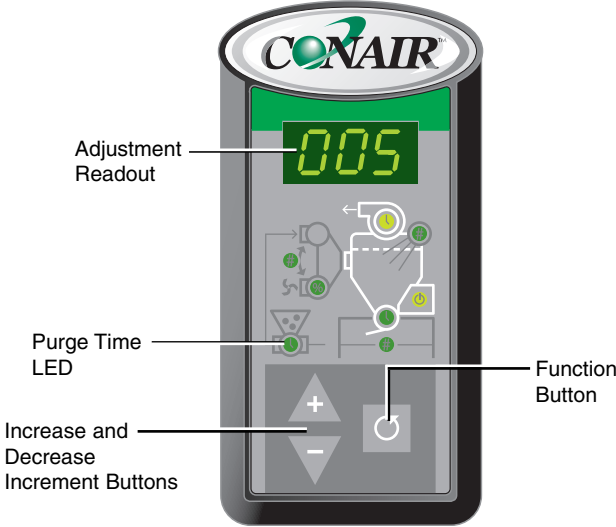

NOTE: When using purge, the ratio layer settings will default to one (1). (One layer of virgin material and one layer of regrind material regardless of the ratio percentage setting.)

To adjust the duration of Purge Time:

- 1 Press the Function button** until the Purge Time LED is lit.
- 2 Use the (+) and (-) buttons to the left of the Function button to increase or decrease the Purge Time duration.** Holding down the (+) or (-) buttons will cause the number to ramp up or down at a faster rate. (The purge time range is 0 - 120 seconds) Changes will be displayed in the ControlMate's three-digit adjustment readout display.
- 3 The control will automatically return to its default Power-on screen** after 30 seconds.

ControlMate™ Pendant Operation

(continued)

Adjusting Load Time

 **NOTE:** The ELC loading control's default load time is loader/receiver model dependent and will be set by Conair.

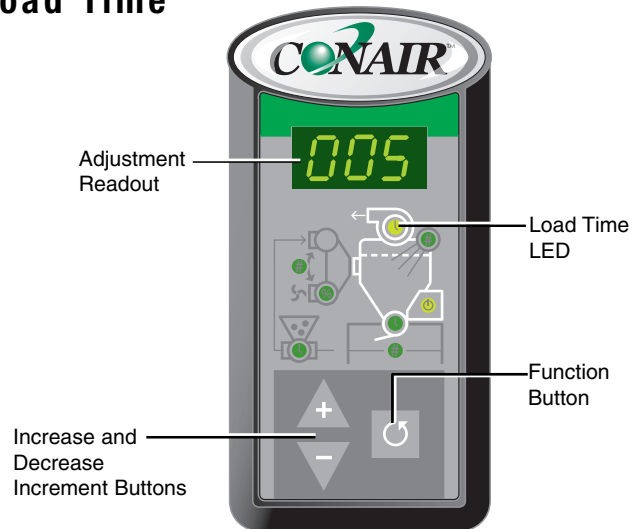

Setup for Load Time using the optional ControlMate pendant will operate exactly as the ELC control. *See Operation section entitled, ELC Loading Control Operation, Load Time Adjustment.*

To adjust Load Time with the enhanced controller:

- 1 Press the Function button** until the Load Time LED is lit.
- 2 Adjust the Load Time through trial and error using the (+) and (-) buttons to the left of the Function button to increase or decrease the amount of load time.** Several adjustments may be needed to optimize your loading time. Holding down the (+) or (-) buttons will cause the number to ramp up or down at a faster rate. The range of Load Time adjustment is 3 - 120 seconds. Changes will be displayed in the ControlMate's three-digit adjustment readout display.
- 3 The control will automatically return to its default Power-on screen** after 30 seconds.

ControlMate™ Pendant Operation

(continued)

Adjusting Load Time (continued)

If your loader/receiver is equipped with a “fill sensor” (a capacitance sensor, mounted in the loader/receiver body), the load time should be set slightly higher than your typical load time, due to the fill sensor terminating the loading cycle once it detects material. A correctly adjusted fill sensor will automatically optimize your loading cycles. The ELC control will signal an alarm if the fill sensor does not see any material by the time the load time setting expires.

- ❖ **TIP:** To avoid nuisance alarms, set the load time duration higher than the duration it takes to satisfy the fill sensor.

ControlMate™ Pendant Operation

(continued)

Using Blowback

-  **NOTE:** Activating and altering this setting is possible only through the optional ControlMate pendant. See *Operation Section entitled, ControlMate Pendant Operation*.

Loaders/receivers equipped with blowback function use air pulses to clean their internal filter. Internal jumpers on the ELC’s control board are set to activate three blowback pulses as standard. These jumpers can be configured to active one to seven pulses, by removing or relocating the jumpers. However, when blowback is accessed through the optional ControlMate pendant it is possible to override the internal setting of the blowback jumpers in favor of the amount set using the pendant. See *Operation section entitled, ELC Loading Control Operation, Using BlowBack*.

-  **NOTE:** One blowback cycle is 1.5 seconds (0.5 second pulse followed by 1 second off). The amount of blowback pulses is limited to the total amount of unload time.

ControlMate™ Pendant Operation

(continued)

Using Blowback (continued)

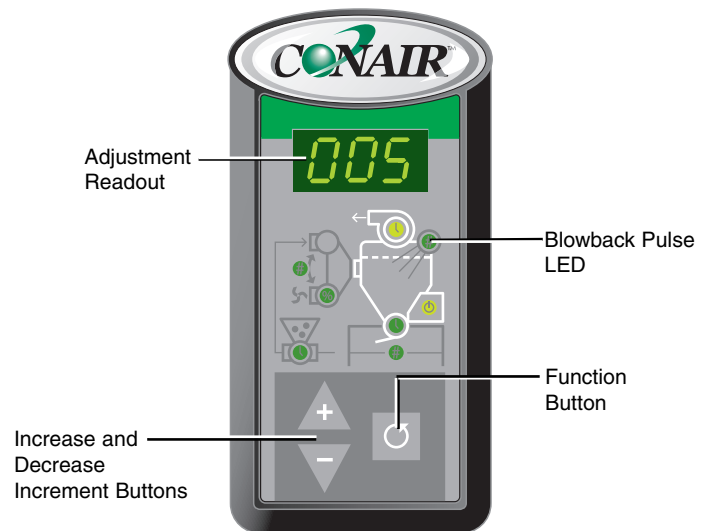

To adjust the number of blowback pulses:

- 1 Press the Function button** until the Blowback Pulse LED is lit.
- 2 Use the (+) and (-) buttons to the left of the Function button to increase or decrease the number of blowback pulses.** Holding down the (+) or (-) buttons will cause the number to ramp up or down at a faster rate. (The blowback pulse range is 0 - 10 pulses) Changes will be displayed in the ControlMate's three-digit adjustment readout display.
- 3 The control will automatically return to its default Power-on screen** after 30 seconds.

User Level 2 Settings for the ControlMate™ Pendant

 **NOTE:** Activating and altering this setting is possible only through the optional ControlMate pendant. See *Operation Section entitled, ControlMate Pendant Operation*.

The settings in User Level 2 of the ControlMate pendant are configured to match your associated loader/receiver operation features.

To access User Level 2 settings:

- 1 Press the Function button down for 5 seconds.** A three-digit number will appear displaying the first option of User Level 2. The first number will be the option number, then a decimal point followed by a zero and then either the digit one or zero. The last digit represents whether the option has been activated, “0” signifies that the option is not activated and “1” indicates that it has been activated. Each function will have a corresponding number 1 - 8.
- 2 Use the Function button to scroll through the user level options.** There are eight functions in User Level 2 (priority demand, demand sensor logic, fill sensor logic, fill sensor present, load and hold, purge/pocket option installed, ratio option installed and blowback option installed).
- 3 Use the (+) or (-) buttons to activate or deactivate the options setting.** If no changes have been made the ControlMate will return to the User Level 1 default screen after 30 seconds.

 **NOTE:** All User Level 2 settings will be set at Conair. Priority Demand will be the only user changeable setting that does not require additional hardware.

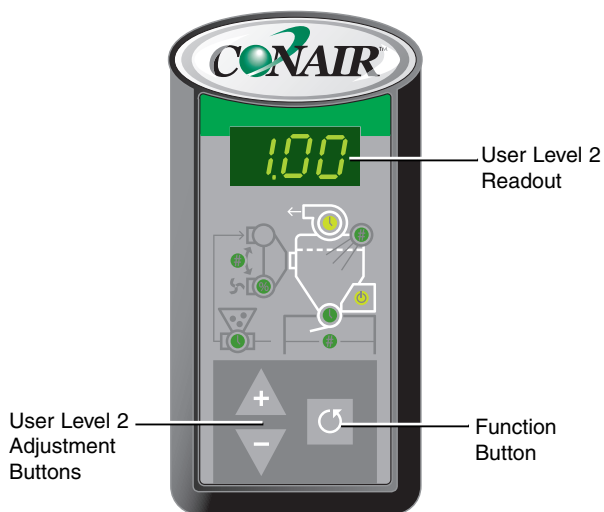
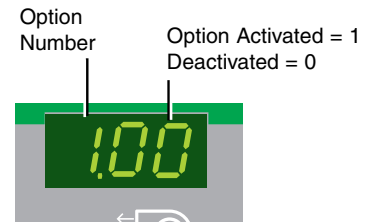

User Level 2 Settings for the ControlMate™ Pendant

(continued)

1.0x - Priority Demand - This feature allows you to override the FIFO (First-In/First-Out) standard demand setting. Receivers with this option activated will always be the first to receive material regardless of other receiver demand signals. (If more than one receiver is set with priority demand the control with setup receiver demands with two demand tiers.

1 = Installed

0 = Not installed

2.0x - Demand Sensor Logic - This setting determines the type of circuit used for the demand sensor. The setting is defaulted to a normally closed circuit which will provide a demand signal when it senses there is no material.

1 = close on demand (24 VDC)

0 = open on demand (0 VDC)

3.0x - Fill Sensor Logic - This setting determines the type of circuit used for the fill sensor. The setting is defaulted to a normally closed circuit which will provide a demand signal when it senses there is no material.

1 = Installed

0 = Not installed

4.0x - Fill Sensor Present -

1 = Installed

0 = Not installed

5.0x - Load and Hold -

1 = Installed

0 = Not installed

6.0x - Purge/APV Option -

1 = Installed

0 = Not installed

7.0x - Ratio Option -

1 = Installed

0 = Not installed

8.0x - Blowback Option -

1 = Installed

0 = Not installed

Maintenance

Preventative maintenance checklist 5-2

Preventative Maintenance Checklist

Routine maintenance will ensure optimum operation and performance of the ELC control and optional ControlMate pendant. We recommend the following maintenance schedule and tasks.

- **Every six months**

- Inspect all wiring connections**

Power and cable connections between the ELC and conveying loaders or receivers may become loose or wires may become worn. Tighten any loose connections and replace any wire or cable that has become worn or damaged.

- Inspect optional ControlMate pendant connection**

Check ControlMate pendant for any loose connection points or frayed wiring. Replace as necessary.

- Inspect the installation**

Check installed mounting hardware to make sure that the installation is secure.

Replacement ControlMate communication cables are available from Conair.

Contact Conair Parts
(800) 458 1960
From outside of the
United States, call:
(814) 437 6861

Troubleshooting

Before beginning 6-2

A few words of caution 6-3

DIAGNOSTICS

Troubleshooting: ELC-M control 6-4

Troubleshooting: ELC-16 control 6-6

Troubleshooting: Optional ControlMate
pendant and pump control 6-8

Before Beginning

You can avoid most problems by following the recommended installation and maintenance procedures outlined in this User Guide. If you do have a problem, this section will help you determine what caused it and how to fix it.

❑ Diagnose causes from the ELC control.

- 1** Press  once to acknowledge and silence the audible alarm and resume control if required. (Alarm acknowledgements can only be done from the ELC module.)
- 2** Address the alarm and fix the problem.
- 3** If the alarm reappears the problem was not fixed.

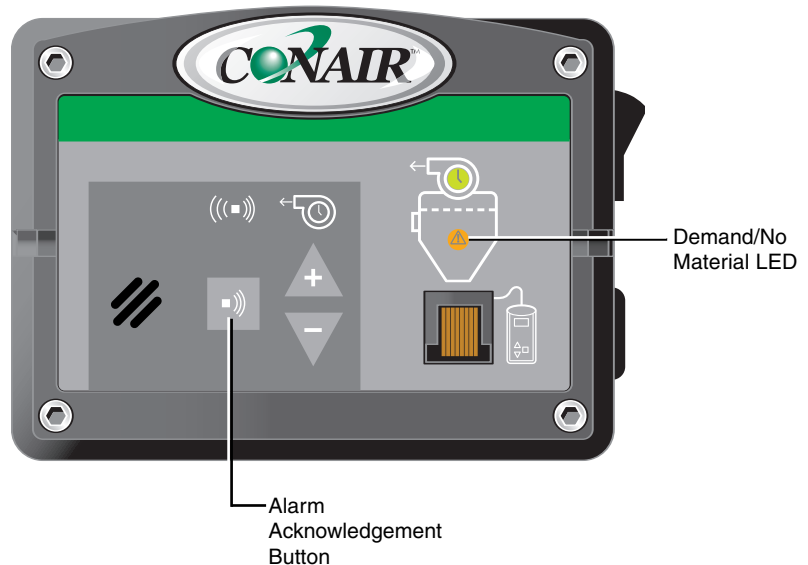

A Few Words of Caution

Improper corrective actions can lead to hazardous conditions and should never be attempted to sustain production.



WARNING: Improper installation, operation, or servicing may result in equipment damage or personal injury.

This equipment should be installed, adjusted, and serviced by qualified technical personnel who are trained in the operation and troubleshooting of this equipment.



DANGER: Electrical shock hazard

Only a qualified electrical technician, trained in the use of this equipment and in avoiding exposure to voltage hazards, should perform procedures that require access to the ELC while power is on.



DANGER: Electrical shock hazard

The ELC loading control allows operators and maintenance personnel to disable and enable conveying system components. Unexpected energization of these components could result in equipment damage or injury.

Troubleshooting: ELC-M Control

Problem	Possible cause	Solution
<p>The ELC-M does not have power.</p>	<p>The ELC-M’s power switch is not turned on.</p>	<p>Turn the ELC-M’s power switch to the “On” position. <i>See Installation section entitled, Powering the ELC Control.</i></p>
	<p>Power connection is loose or detached.</p>	<p>Ensure that the ELC-M’s power supply is connected. <i>See Installation section entitled, Connecting Main Power to the ELC-M Control.</i></p>
	<p>Circuit breaker has been tripped.</p>	<p>Turn the ELC-M’s power switch “Off” and then “On”. <i>See Installation section entitled, Powering the ELC Control.</i></p>
	<p>Incoming voltage is incorrect.</p>	<p>Checking for correct incoming power voltage and amp ratings.</p>
<p>The ELC-M has power, but it fails to start a load cycle. (Demand LED is off.)</p>	<p>The demand sensor indicator located on the front of the ELC-M is not illuminated showing that there is no demand for material.</p>	<p>Check demand sensors (reed switch or optional capacitive demand sensors). Clean or adjust if necessary.</p>
	<p>Material line is clogged.</p>	<p>Check material lines, clean as necessary.</p>
	<p>Material line does not have vacuum.</p>	<p>Disconnect any compressed air source. See loader manual to correct vacuum connections.</p>
		<p>Loader motor has failed, replace motor.</p>





WARNING: Any electrical checks should be performed by a qualified electrician.

Troubleshooting: ELC-M Control (continued)

Problem	Possible cause	Solution
Alarm has sounded during a load attempt. (Demand LED is flashing.)	Material plug within the conveying line has stopped the flow of material.	Check the material line, clear any obstructions.
	Foreign object within the material.	Check the material line, clear any foreign objects.
	Material line is damaged.	Check the material line, replace any damaged hoses.
	Optional internal fill sensor has not been satisfied before the load time setting has expired.	Reset the ELC-M's load time slightly higher than the time required to meet the loader's optional internal fill sensor. <i>See Operation section entitled, ELC Loading Control Operation, Load Time Adjustment.</i>
		<i>See Operation section entitled, ControlMate Pendant Operation, Adjusting Load Time.</i>
	Demand sensor is damaged or not adjusted properly.	Check the demand sensor, replace as necessary.
	Optional remote demand sensor is dirty.	Clean the optional remote demand sensor.

Troubleshooting: ELC-16 Control

Problem	Possible cause	Solution
The ELC-16 does not have power.	The ELC-16's power switch is not turned on.	Turn the ELC-16's power switch to the "On" position. <i>See Installation section entitled, Powering the ELC Control.</i>
	The pump control's power switch is not turned on.	Turn the pump control's power switch to the "On" position. <i>See Installation section entitled, Powering the Pump Control.</i>
	Power connection is loose or detached.	Ensure that the ELC-16's power supply is connected. <i>See Installation section entitled, Connecting the ELC-16 Control to the Junction Box Drop Cable.</i>
	Circuit breaker has been tripped.	Reset the ELC-16's or pump control's circuit breaker. <i>See Operation section entitled, Powering the Pump Control and Powering the ELC Control.</i>
	Incoming voltage is incorrect.	Checking for correct incoming power voltage and amp ratings.  WARNING: Any electrical checks should be performed by a qualified electrician.
	The incoming power connection from the pump control to the junction box is loose or not connected.	Check the incoming power connection from the pump control to the junction box. <i>See Installation section entitled, Wiring the ELC-16 Control Junction Boxes.</i>  WARNING: Any electrical checks should be performed by a qualified electrician.
	The pump control is not connected to a power source.	Check all pump control connections, secure if necessary. See wiring diagram for reference.

Troubleshooting: ELC-16 Control (continued)

Problem	Possible cause	Solution
<p>The ELC-16 has power, but it fails to start a load cycle. (Demand LED is off.)</p> <p> CAUTION: Wear eye protection. If you use compressed air to clean the equipment, you must wear eye protection and observe all OSHA and other safety regulations pertaining to the use of compressed air.</p>	<p>The demand sensor indicator located on the front of the ELC-16 is not illuminated showing that there is no demand for material.</p> <p>Material line is clogged.</p> <p>Material line does not have vacuum.</p> <p>There is no communication between the ELC-16 and the pump control.</p>	<p>Check demand sensors (reed switch or optional capacitive demand sensors). Clean or adjust if necessary.</p> <p>Check the material line, clear any obstructions. See receiver manual to correct vacuum connections.</p> <p>Check all ELC-16 connections. <i>See Installation section entitled, Connecting the ELC-16 Control Junction Boxes and Wiring the ELC-16 Pump Control.</i></p>
<p>Alarm has sounded during a load attempt. (Demand LED is flashing.)</p>	<p>Material plug within the conveying line has stopped the flow of material.</p> <p>Foreign object within the material.</p> <p>Material line is damaged.</p> <p>Optional internal fill sensor has not been satisfied before the load time setting has expired.</p> <p>Demand sensor is damaged or not adjusted properly.</p> <p>Optional remote demand sensor is dirty.</p>	<p>Check the material line, clear any obstructions.</p> <p>Check the material line, clear any foreign objects.</p> <p>Check the material line, replace any damaged hoses.</p> <p>Reset the ELC-16's load time slightly higher than the time required to met the loader's optional internal fill sensor. <i>See Operation section entitled, ELC Loading Control Operation, Adjusting Load Time.</i></p> <p>Check the demand sensor, replace as necessary.</p> <p>Clean the optional remote demand sensor.</p>

Troubleshooting: Optional ControlMate™ Pendant and Pump Control

Problem	Possible cause	Solution
<p>ControlMate pendant does not have power.</p> <p>Replacement ControlMate pendants and communication cables are available from Conair.</p> <p>Contact Conair Parts (800) 458 1960 From outside of the United States, call: (814) 437 6861</p>	<p>The ControlMate pendant is not connected to the ELC module.</p>	<p>Check communication connection points between the ELC module and ControlMate, reconnect if necessary. <i>See Operation section entitled, ControlMate Pendant Operation, Connecting the ControlMate Pendant.</i></p>
	<p>The ControlMate communication cable is loose.</p>	<p>Replace damaged ControlMate communication cable.</p>
	<p>The ControlMate communication cable is damaged.</p>	<p>Turn on the power to the ELC. <i>See Installation section entitled, Powering the ELC Control.</i></p>
	<p>ELC's power is not turned on.</p>	<p>Reset the ELC circuit breaker. <i>See Installation section entitled, Powering the ELC Control.</i></p>
	<p>ELC's circuit breaker has been tripped.</p>	<p>Turn on the power to the pump control. <i>See Installation section entitled, Powering the Pump Control.</i></p>
	<p>ELC-16's pump control is not turned on.</p>	<p>Reset the pump control's circuit breaker. <i>See Installation section entitled, Powering the Pump Control.</i></p>
	<p>The pump control's circuit breaker has been tripped.</p>	<p>Replace ControlMate pendant.</p>
	<p>The ControlMate pendant is damaged.</p>	

Troubleshooting: Optional ControlMate™ Pendant and Pump Control (continued)

Problem	Possible cause	Solution
<p>ControlMate has power, but is not communicating with the ELC control. (No heartbeat)</p> <p>Replacement ControlMate communication cables are available from Conair.</p> <p>Contact Conair Parts (800) 458 1960 From outside of the United States, call: (814) 437 6861</p>	<p>The ControlMate communication cable is damaged.</p> <p>CAN open network is not communicating with the ELC-16 control. Junction box connections are loose or detached.</p>	<p>Replace damaged ControlMate communication cable.</p> <p>Check junction box connections. <i>See Installation section entitled, Wiring the ELC-16 Control Junction Boxes.</i></p> <p> WARNING: Any electrical checks should be performed by a qualified electrician.</p>
<p>The pump control's Demand LED is not illuminated.</p>	<p>No demand signal on the CAN open network. There is no communication between the ELC-16 and the pump control.</p> <p>The pump control does not have power.</p> <p>The pump control's circuit breaker has been tripped.</p>	<p>Check all ELC-16 connections. <i>See Installation section entitled, Connecting the ELC-16 Control Junction Boxes and Wiring the ELC-16 Pump Control.</i></p> <p>Turn on the power to the pump control. <i>See Installation section entitled, Powering the Pump Control.</i></p> <p>Reset the pump control's circuit breaker. <i>See Installation section entitled, Powering the Pump Control.</i></p>

Troubleshooting: Optional ControlMate™ Pendant and Pump Control

Problem	Possible cause	Solution
The pump control's Load LED is not illuminated.	No demand signal on the CAN open network. There is no communication between the ELC-16 and the pump control.	Check all ELC-16 connections. <i>See Installation section entitled, Connecting the ELC-16 Control Junction Boxes and Wiring the ELC-16 Pump Control.</i>
	The pump control does not have power.	Turn on the power to the pump control. <i>See Installation section entitled, Powering the Pump Control.</i>
	The pump control's circuit breaker has been tripped.	Reset the pump control's circuit breaker. <i>See Installation section entitled, Powering the Pump Control.</i>

We're Here to Help

Conair has made the largest investment in customer support in the plastics industry. Our service experts are available to help with any problem you might have installing and operating your equipment. Your Conair sales representative also can help analyze the nature of your problem, assuring that it did not result from misapplication or improper use.

Additional manuals and prints for your Conair equipment may be ordered through the Customer Service or Parts Department for a nominal fee. Most manuals can be downloaded free of charge from the product section of the Conair website.
www.conairgroup.com

How to Contact Customer Service

To contact Customer Service personnel, call:



 **NOTE:** Normal operating hours are 8:00 am - 5:00 pm. After hours emergency service is available at the same phone number.

You can commission Conair service personnel to provide on-site service by contacting the Customer Service Department.

Before You Call...

If you do have a problem, please complete the following checklist before calling Conair:

- Make sure you have all model, control type and serial numbers from the serial tag, and parts list numbers for your particular equipment. Service personnel will need this information to assist you..
- Make sure power is supplied to the equipment.
- Make sure that all connectors and wires within and between control systems and related components have been installed correctly.
- Check the troubleshooting guide of this manual for a solution.
- Thoroughly examine the instruction manual(s) for associated equipment, especially controls. Each manual may have its own troubleshooting guide to help you.
- Check that the equipment has been operated as described in this manual.
- Check accompanying schematic drawings for information on special considerations.

Equipment Guarantee

Conair guarantees the machinery and equipment on this order, for a period as defined in the quotation from date of shipment, against defects in material and workmanship under the normal use and service for which it was recommended (except for parts that are typically replaced after normal usage, such as filters, liner plates, etc.). Conair's guarantee is limited to replacing, at our option, the part or parts determined by us to be defective after examination. The customer assumes the cost of transportation of the part or parts to and from the factory.

Performance Warranty

Conair warrants that this equipment will perform at or above the ratings stated in specific quotations covering the equipment or as detailed in engineering specifications, provided the equipment is applied, installed, operated and maintained in the recommended manner as outlined in our quotation or specifications.

Should performance not meet warranted levels, Conair at its discretion will exercise one of the following options:

- Inspect the equipment and perform alterations or adjustments to satisfy performance claims. (Charges for such inspections and corrections will be waived unless failure to meet warranty is due to misapplication, improper installation, poor maintenance practices or improper operation.)
- Replace the original equipment with other Conair equipment that will meet original performance claims at no extra cost to the customer.
- Refund the invoiced cost to the customer. Credit is subject to prior notice by the customer at which time a Return Goods Authorization Number (RGA) will be issued by Conair's Service Department. Returned equipment must be well crated and in proper operating condition, including all parts. Returns must be prepaid.

Purchaser must notify Conair in writing of any claim and provide a customer receipt and other evidence that a claim is being made.

Warranty Limitations

Except for the Equipment Guarantee and Performance Warranty stated above, Conair disclaims all other warranties with respect to the equipment, express or implied, arising by operation of law, course of dealing, usage of trade or otherwise, including but not limited to the implied warranties of merchantability and fitness for a particular purpose.