



## **WARNING - Reliance on this Manual Could Result in Severe Bodily Injury or Death!**

This manual is out-of-date and is provided only for its technical information, data and capacities. Portions of this manual detailing procedures or precautions in the operation, inspection, maintenance and repair of the product forming the subject matter of this manual may be inadequate, inaccurate, and/or incomplete and cannot be used, followed, or relied upon. Contact Conair at [info@conairgroup.com](mailto:info@conairgroup.com) or 1-800-654-6661 for more current information, warnings, and materials about more recent product manuals containing warnings, information, precautions, and procedures that may be more adequate than those contained in this out-of-date manual.



USER GUIDE

UGD022/0304

# D Carousel Dryer - DC

Models 15, 25, 50, 75, and 100 with DC Controls



**INTRODUCTION** • Purpose of the User Guide • How the guide is organized • Your responsibilities as a user • **ATTENTION:** Read this so no one gets hurt • How to use the lockout device • **DESCRIPTION** • What is the D Carousel Dryer? • Typical applications • How it works • Specifications: D Dryer • **INSTALLATION** • Unpacking the boxes • Preparing for installation • Mounting the dryer and hopper on a Processing Machine • Positioning the dryer on the floor; Mounting the hopper on the throat • Mounting the dryer on the floor stand; Hopper on the throat • Mounting the dryer and hopper on the mobile floor stand • Connecting the main power • Checking for proper air flow • Connecting the air hoses • Connecting water hoses • Connecting the RTD probe • Mounting a loader on the hopper • **OPERATION** • How it works • The DC dryer control panel • D dryer DC control functions • Control Function Description • To start drying • To stop drying • Using the auto start countdown function • Setting high and low setpoint limits • **MAINTENANCE**

Please record your equipment's model and serial number(s) and the date you received it in the spaces provided.

It's a good idea to record the model and serial number(s) of your equipment and the date you received it in the User Guide. Our service department uses this information, along with the manual number, to provide help for the specific equipment you installed.

Please keep this User Guide and all manuals, engineering prints and parts lists together for documentation of your equipment.

Date:

Manual Number: UGD022/0304

Serial Number(s):

Model Number(s):

**DISCLAIMER:** The Conair Group, Inc., shall not be liable for errors contained in this User Guide or for incidental, consequential damages in connection with the furnishing, performance or use of this information. Conair makes no warranty of any kind with regard to this information, including, but not limited to the implied warranties of merchantability and fitness for a particular purpose.

# Table of Contents

## 1-1 Introduction

Purpose of the User Guide . . . . .	1-2
How the guide is organized . . . . .	1-2
Your responsibilities as a user . . . . .	1-3
ATTENTION: Read this so no one gets hurt . . . . .	1-4
How to use the lockout device . . . . .	1-5

## 2-1 Description

What is the D Carousel Dryer? . . . . .	2-2
Typical applications . . . . .	2-2
How it works . . . . .	2-4
Specifications: D Dryer . . . . .	2-6

## 3-1 Installation

Unpacking the boxes . . . . .	3-2
Preparing for installation . . . . .	3-4
Mounting the dryer and hopper on a Processing Machine . . . . .	3-6
Positioning the dryer on the floor; Mounting the hopper on the throat . . . . .	3-8
Mounting the hopper . . . . .	3-9
Positioning the dryer on the floor . . . . .	3-9
Mounting the dryer on the floor stand; Hopper on the throat. . . . .	3-10
Mounting the dryer and hopper on the mobile floor stand . . . . .	3-10
Connecting the main power . . . . .	3-10
Checking for proper air flow . . . . .	3-12

Connecting the air hoses . . . . .	3-15
Connecting water hoses . . . . .	3-15
Connecting the RTD probe . . . . .	3-16
Mounting a loader on the hopper . . . . .	3-17
Testing the installation . . . . .	3-17

## 4-1 Operation

The DC dryer control panel . . . . .	4-2
D dryer DC control functions . . . . .	4-3
Control function flow chart . . . . .	4-3
Control function descriptions . . . . .	4-6
To start drying . . . . .	4-20
To stop drying . . . . .	4-20

## 5-1 Maintenance

Preventative maintenance checklist . . . . .	5-2
Cleaning the hopper . . . . .	5-3
Cleaning the process filter . . . . .	5-4
Cleaning the regeneration filter . . . . .	5-4
Cleaning the aftercooler coils . . . . .	5-5
Cleaning the precooler coils . . . . .	5-5
Inspecting hoses and gaskets . . . . .	5-5

## 6-1 Troubleshooting

Before beginning . . . . .	6-2
A few words of caution . . . . .	6-3
<u>DIAGNOSTICS</u>	
How to identify the cause of a problem . . . . .	6-4
Shut down alarms . . . . .	6-5
Passive alarms . . . . .	6-10
<u>REPAIR</u>	
Replacing fuses . . . . .	6-11
Checking heater solid state relays . . . . .	6-12
Checking or replacing temperature sensors. . . . .	6-13
Adjusting the limit switch. . . . .	6-14
Replacing the heaters . . . . .	6-15
Replacing the desiccant tanks . . . . .	6-19
Refilling the desiccant tanks. . . . .	6-20

## A Appendix

We're Here to Help . . . . .	A-1
How to Contact Customer Service . . . . .	A-1
Before You Call... . . . .	A-1
Equipment Guarantee . . . . .	A-2
Performance Warranty . . . . .	A-2

## B Appendix

Mounting the Dryer on a Floor Stand . . . . .	B-1
Mounting the Dryer and Hopper on a Mobile Floor stand . . . . .	B-2

## **C** Appendix

Installing an aftercooler (optional) .....	C-1
Cleaning the aftercooler .....	C-3

## **D** Appendix

Installing a precooler (optional) .....	D-1
Cleaning the precooler .....	D-3

# Introduction

---

Purpose of the user guide . . . . .	1-2
How the guide is organized . . . . .	1-2
Your responsibilities as a user . . . . .	1-3
ATTENTION:	
Read this so no one gets hurt . . . . .	1-4
How to use the lockout device . . . . .	1-5

# Purpose of the User Guide

This User Guide describes the Conair D series of carousel dehumidifying dryers and explains step-by-step how to install, operate, maintain and repair this equipment.

Before installing this product, please take a few moments to read the User Guide and review the diagrams and safety information in the instruction packet. You also should review manuals covering associated equipment in your system. This review won't take long, and it could save you valuable installation and operating time later.

# How the Guide is Organized

Symbols have been used to help organize the User Guide and call your attention to important information regarding safe installation and operation.



Symbols within triangles warn of conditions that could be hazardous to users or could damage equipment. Read and take precautions before proceeding.



Numbers indicate tasks or steps to be performed by the user.



A diamond indicates the equipment's response to an action performed by the user.



An open box marks items in a checklist.



A circle marks items in a list.



Indicates a tip. A tip is used to provide you with a suggestion that will help you with the maintenance and operation of this equipment.



Indicates a note. A note is used to provide additional information about the steps you are following throughout this manual.

## Your Responsibility as a User

You must be familiar with all safety procedures concerning installation, operation and maintenance of this equipment. Responsible safety procedures include:

- Thorough review of this User Guide, paying particular attention to hazard warnings, appendices and related diagrams.
- Thorough review of the equipment itself, with careful attention to voltage sources, intended use and warning labels.
- Thorough review of instruction manuals for associated equipment.
- Step-by-step adherence to instructions outlined in this User Guide.

# ATTENTION:

## Read this so no one gets hurt

We design equipment with the user's safety in mind. You can avoid the potential hazards identified on this machine by following the procedures outlined below and elsewhere in the User Guide.



**WARNING: Improper installation, operation, or servicing may result in equipment damage or personal injury.**

This equipment should be installed, adjusted, and serviced by qualified technical personnel who are familiar with the construction, operation, and potential hazards of this type of machine.

All wiring, disconnects, and fuses should be installed by qualified electrical technicians in accordance with electrical codes in your region. Always maintain a safe ground. Do not operate the equipment at power levels other than what is specified on the machine serial tag and data plate.



**WARNING: Voltage hazard**

This equipment is powered by three-phase alternating current, as specified on the machine serial tag and data plate.

A properly sized conductive ground wire from the incoming power supply must be connected to the chassis ground terminal inside the electrical enclosure. Improper grounding can result in severe personal injury and erratic machine operation.

Always disconnect and lock out the incoming main power source before opening the electrical enclosure or performing non-standard operating procedures, such as routine maintenance. Only qualified personnel should perform troubleshooting procedures that require access to the electrical enclosure while power is on.

# How to Use the Lockout Device

 **CAUTION:** Before performing maintenance or repairs on this product, you should disconnect and lockout electrical power sources to prevent injury from unexpected energization or start-up. A lockable device has been provided to isolate this product from potentially hazardous electricity.

Lockout is the preferred method of isolating machines or equipment from energy sources. Your Conair product is equipped with the lockout device pictured below. To use the lockout device:

- 1 Stop or turn off the equipment.**
- 2 Isolate the equipment from the electric power.** Turn the rotary disconnect switch to the OFF, or “O” position.
- 3 Secure the device with an assigned lock or tag.** Insert a lock or tag in the holes to prevent movement.
- 4 The equipment is now locked out.**

 **WARNING:** Before removing lockout devices and returning switches to the ON position, make sure that all personnel are clear of the machine, tools have been removed, and all safety guards reinstalled.

To turn the rotary disconnect back to the ON position:

- 1 Remove the lock or tag.**
- 2 Turn the rotary disconnect switch to the ON or “I” position.**

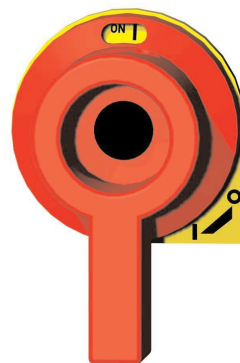
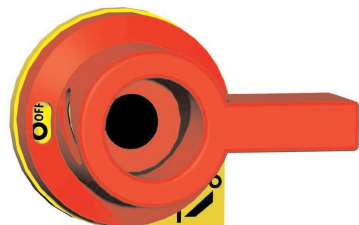



## Description

---

What is the D carousel dryer? . . . . .	2-2
Typical applications . . . . .	2-2
How it works. . . . .	2-4
Specifications: D dryer . . . . .	2-6

# What is the D Carousel Dryer?

The D carousel dehumidifying dryer produces hot, low-dew point air that removes moisture from hygroscopic plastics. The dryer pulls warm, moist air from a drying hopper and pumps it through dehumidifying desiccant. The dryer then heats the air to the drying temperature you selected and circulates it through the material in the hopper.

The dryer's three-tank, closed-loop design ensures a continuous supply of hot, dehumidified air while preventing contamination from moisture in the plant.

## Typical Applications

The D dryer can be mounted beside the hopper on the throat of a processing machine using the optional diving board support frame, or positioned on the floor near the machine using the standard casters. Two mobile floor stand designs are also available.



Dryer and hopper on the processing machine throat using the optional support frame.



Dryer on the floor; hopper on the throat.



Dryer on a floor stand; hopper on the throat.

## Typical Applications (continued)



The D carousel dryer can be used successfully in applications that require:

- A contamination-free drying environment.
- Drying temperatures within the ranges shown in the following table:

Model	Drying Temperature Range
Low temperature (with precooler)*	100° - 150°F (38° - 66°C)
Standard	150° - 250°F (66° - 121°C)
High heat (with aftercooler)	150° - 375°F (66° - 191°C)
Low-high (with aftercooler & precooler)*	100° - 375°F (38° - 191°C)



\* **WARNING:** The precooler must NOT be installed in the process line for temperature setpoints above 150°F (65.5°C). The pre-cooler hoses will absorb too much heat and will result in poor process temperature control.

- Throughput rates of 15 to 100 lbs (6.8 to 37.3 kg) per hour (some materials can be run at a higher rate).
- Dew points of -40°F (-40°C).

If you disregard this warning you will get a loop break alarm.

If you are drying material at temperatures over 250°F (121°C), you will need the high-temperature package that includes an aftercooler. An aftercooler is standard equipment on the High heat and Low-high models.

# How It Works

The D carousel dryer achieves continuous, closed loop drying by passing air simultaneously through two heaters and three tanks of molecular sieve desiccant.

## ■ THE PROCESS (DRYING) CYCLE

The process blower pulls moist air from the top of the drying hopper. The air passes through the process filter (and optional aftercooler, if installed) into the dryer's desiccant tank, where moisture is removed. The now dry air moves through the process heater, where it is heated to the drying temperature selected by the operator. The hot, dry air is delivered to the hopper (after it passes through the optional precooler, if installed) where a spreader cone evenly distributes the air through the material.

## ■ The Regeneration Cycle

The regeneration blower pulls air through the regeneration filter into the dryer's regeneration heater. The air is heated to 425°F (218°C) before it is pushed into the "wet" desiccant tank. The hot air purges moisture from the desiccant. The moist air is blown out the exhaust at the back of the dryer.

## □ The Cooling Cycle

A regenerated desiccant tank must be cooled before it is moved back into the process cycle. The process blower pushes a small amount of air through the regenerated desiccant tank. The cooling air then passes through the optional aftercooler, if installed, and repeats the circuit.

# How It Works (continued)

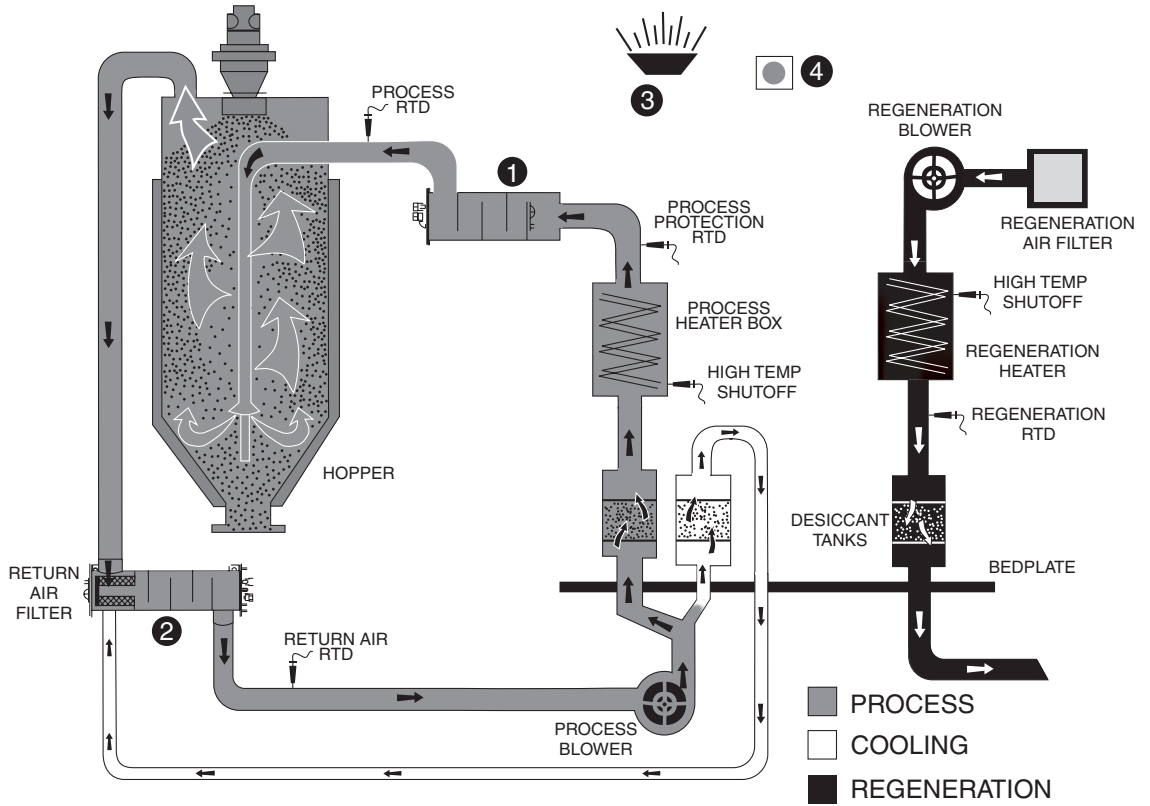

## DRYER OPTIONS

- |               |               |
|---------------|---------------|
| 1 PRECOOLER   | 3 ALARM HORN  |
| 2 AFTERCOOLER | 4 ALARM LIGHT |

# Specifications: D Carousel

## DEHUMIDIFYING DRYERS

### D Small Series Carousel Dryers

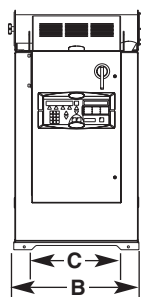
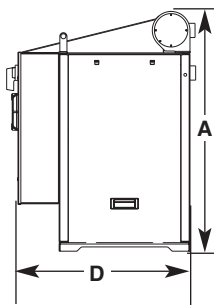

MODEL	D15	D25	D50	D75	D100
<b>Performance characteristics</b> (with full hopper)					
Air flow {SCFM}*	12	20	35	50	80
Air flow {ACFM @ 250°}*	16	27	47	67	107
Drying temperature	All models 100 - 375° F {38 - 191° C} with options				
Dew point	All models -40° F {-40° C}				
<b>Dimensions</b> inches {cm}					
A - Height	35.5 {90.2}	35.5 {90.2}	35.5 {90.2}	42.1 {107}	42.1 {107}
B - Overall width	17.3 {43.9}	17.3 {43.9}	17.3 {43.9}	22.0 {55.9}	22.0 {55.9}
C - Control width	15.7 {39.9}	15.7 {39.9}	15.7 {39.9}	15.7 {39.9}	15.7 {39.9}
D - Depth	24.8 {63.0}	24.8 {63.0}	24.8 {63.0}	30.3 {77.0}	30.3 {77.0}
Control depth	7.3 {18.5}	7.3 {18.5}	7.3 {18.5}	7.3 {18.5}	7.3 {18.5}
Outlet/inlet tube size OD	2.5	2.5	2.5	2.5	2.5
<b>Weight</b> lbs {kg}					
Installed	225 {102}	225 {102}	240 {109}	310 {141}	340 {155}
<b>Voltage</b> † Total Amps					
208 V/3 phase/60 Hz	12.2	12.2	17.7	25.5	NA
240 V/3 phase/60 Hz	10.5	10.5	15.5	22.3	33.1
400 V/3 phase/50 Hz	6.5	6.5	9.3	13.2	18.1
480 V/3 phase/60 Hz	5.3	5.3	7.8	11.2	16.7
575 V/3 phase/60 Hz	4.4	4.4	6.7	9.2	13.9
<b>Total kilowatts</b> kw {BTU/min}	2.2 {125}	2.5 {142}	3.4 {193}	6.1 {347}	9.0 {512}
<b>Water requirements</b> {for optional aftercooler or precooler}					
Recommended temperature*	45° - 85° F		45° - 85° F		
Water flow gal./min. {liters/min.}	1 {3.8}		2 {7.6}		
Water connections NPT	1/2 inch NPT				

#### SPECIFICATION NOTES:

\* SCFM stands for standard cubic feet per minute, referenced to a pre-specified pressure, temperature and relative humidity. In most cases, SCFM is referenced to 14.7 PSIA 68° F and 0% relative humidity. ACFM stands for actual cubic feet per minute, and must be supplied with a temperature reference, due to the change in air density with temperature. Because dryers operate at a relatively low pressure the effects on air density are negligible.

† Dryers running at 50 HZ will have 17% less airflow, and a 17% reduction in material throughput.

Specifications may change without notice. Consult a Conair representative for the most current information.

# Specifications: D Carousel (continued)

## OPTIONAL HOPPERS AND MOUNTING BRACKET

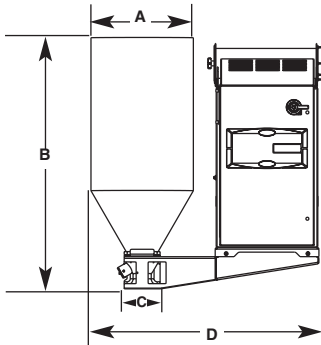

HOPPER MODEL	CH10-0.5	CH10-1	CH10-1.5	CH14-2	CH14-3	CH14-4
<b>Hopper / Mounting Frame Dimensions inches (cm)</b>						
A - Insulated hopper diameter	12.5 {13.8}	12.5 {31.8}	12.5 {31.8}	17 {43.2}	17 {43.2}	17 {43.2}
B - Overall height	32 {81.3}	43 {109.2}	54 {137.2}	45 {114.3}	56 {142.2}	67 {170.2}
C - Base plate, square	7.5 {19}	7.5 {19}	7.5 {19}	6.5 {16.5}	6.5 {16.5}	6.5 {16.5}
D - Width with insulated hopper	39 {99.1}	39 {99.1}	39 {99.1}	41 {104.1}	41 {104.1}	41 {104.1}
<b>Volume</b> ft <sup>3</sup> {liters}	0.5 {9.4}	1 {28.3}	1.5 {42.5}	2 {56.6}	3 {85}	4 {113.2}
<b>Capacity</b> lb {kg} @40 lb/ft <sup>3</sup>	20 {9.0}	40 {18.1}	60 {27.2}	80 {36.3}	120 {54.4}	160 {72.5}
<b>Mounting Frame Weight</b> lb {kg}	30 {13.6}	30 {13.6}	30 {13.6}	35 {15.9}	35 {15.9}	35 {15.9}
<b>Hopper Weight</b> lb {kg}						
Insulated	40 {18.1}	50 {22.7}	70 {31.7}	80 {36.32}	95 {43.1}	110 {48.9}

HOPPER MODEL	CH18-4	CH18-6	CH24-8	CH24-12	CH24-15
<b>Hopper / Mounting Frame Dimensions inches (cm)</b>					
A - Insulated hopper diameter	21 {53.3}	21 {53.3}	27 {68.58}	27 {68.58}	27 {68.58}
B - Overall height	48 {121.9}	68 {172.7}	64 {162.6}	79 {200.7}	90 {228.6}
C - Base plate, square	6.5 {16.5}	6.5 {16.5}	6.5 {16.5}	6.5 {16.5}	6.5 {16.5}
D - Width	47.63 {121.0}	47.63 {121.0}	47.63 {121.0}	50.63 {128.6}	50.63 {128.6}
<b>Volume</b> ft <sup>3</sup> {liters}	4 {113.3}	6 {169.9}	8 {226.5}	12 {339.8}	15 {424.8}
<b>Capacity</b> lb {kg} @40 lb/ft <sup>3</sup>	160 {72.5}	240 {108.9}	320 {145.1}	480 {217.7}	600 {272.2}
<b>Mounting Frame Weight</b> lb {kg}	50 {22.7}	50 {22.7}	70 {31.7}	70 {31.7}	70 {31.7}
<b>Hopper Weight</b> lb {kg}					
Insulated	145 {66}	165 {75}	210 {95}	235 {107}	255 {116}

### MOUNTING PATTERNS Standard Base Plate IB02

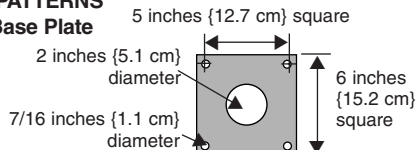

### Optional Base Plate IB01

(for mounting CH10 and CH14 hoppers independent of dryer only)

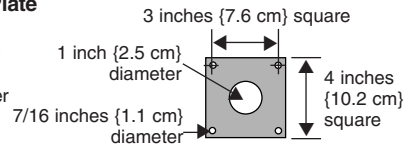



## Installation

---

Unpacking the boxes . . . . .	3-2
Preparing for installation . . . . .	3-4
Mounting the dryer and hopper on a processing machine . . . . .	3-6
Positioning the dryer on the floor; mounting the hopper on the throat . . . . .	3-8
Mounting the hopper . . . . .	3-9
Positioning the dryer on the floor . . . . .	3-9
Mounting the dryer on the floor stand; hopper on the throat . . . . .	3-10
Mounting the dryer and hopper on the mobile floor stand . . . . .	3-10
Connecting the main power . . . . .	3-10
Checking for proper air flow . . . . .	3-12
Connecting the air hoses . . . . .	3-15
Connecting the water hoses . . . . .	3-15
Connecting the RTD probe . . . . .	3-16
Mounting a loader on the hopper . . . . .	3-17
Testing the installation . . . . .	3-17

# Unpacking the Boxes

The D carousel dryer comes in one to four boxes, depending on the model and options ordered. The boxes could include (depends on options selected):

## Mounting Hardware:

### Floor stand option:

- four 5/16-18 self-locking bolts
- four hose clamps

### Support frame option:

- eight 3/8-16 self-locking bolts
- four 5/16-18 self-locking bolts
- four hose clamps



**NOTE:** You must position the dryer on the floor or mount it to a floor stand if your processing machine throat opening is 1 inch (2.54 cm) diameter or smaller and requires a 3x3 inch (7.6x7.6 cm) or smaller bolt pattern.

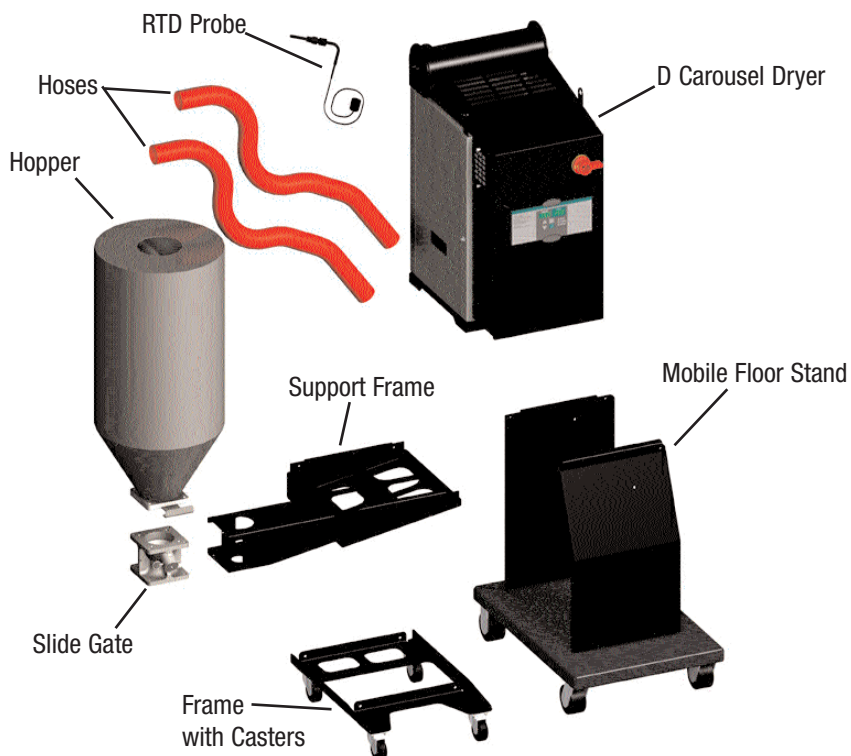

- 1 Carefully remove the dryer and components** from their shipping containers, and set upright. Note that the dryer is secured to its shipping container with four bolts that pass through the bottom of the dryer frame. These bolts are accessed by removing the side panels of the dryer.
- 2 Remove all packing material**, protective paper, tape, and plastic, including any inserted in the top section of the dryer. Be sure to remove the side panels from the dryer and cut and remove three (3) tie wraps securing the bedplates. Also cut and remove the tie wrap on the bedplate limit switch. Remove the C-clamp on the bedplate.
- 3 Carefully inspect all components** to make sure no damage occurred during shipping, and that you have all the necessary hardware.

## Unpacking the Boxes (continued)

**4 Take a moment to record serial numbers** and electrical power specifications in the blanks provided on the back of the the User Guide's title page. The information will be helpful if you ever need service or parts.

**5 You are now ready to begin installation.**

Follow the preparation steps on the next page, then choose one of the three mounting options:

- Dryer and hopper on the processing machine throat using the optional support frame (see page 3-6).
- Dryer on the floor; hopper on the throat (see page 3-8).
- Dryer on a floor stand; hopper on the throat (see Appendix B).

# Preparing for Installation

The D carousel dryer is easy to install if you plan the location and prepare the mounting area properly.

## 1 Make sure the mounting area provides:

❑ **A grounded power source supplying the correct current and voltage** for your dryer model. Check the dryer's serial tag for the correct amps, voltage, phase, and cycles. Field wiring should be completed by qualified personnel to the planned location for the dryer. All electrical wiring should comply with your region's electrical codes.

❑ **A source of water, if you have an aftercooler and / or precooler.** The D dryer's optional aftercooler and precooler can use 1-2 gals./min. (3.8-7.6 liters/min.) tower, city, or chiller water at temperatures of 40° to 85°F (4° to 29°C). Pipe should be run to the planned dryer location. Use flexible hose to connect the water pipes to the aftercooler and precooler.

### ❑ **Minimum clearance for safe operation and maintenance.**

You should maintain 24 in. (61 cm) clearance on at least three sides of the dryer. If the dryer is mounted with a hopper on a processing machine throat, clearance between the dryer and hopper can be 4 in. (10.2 cm).

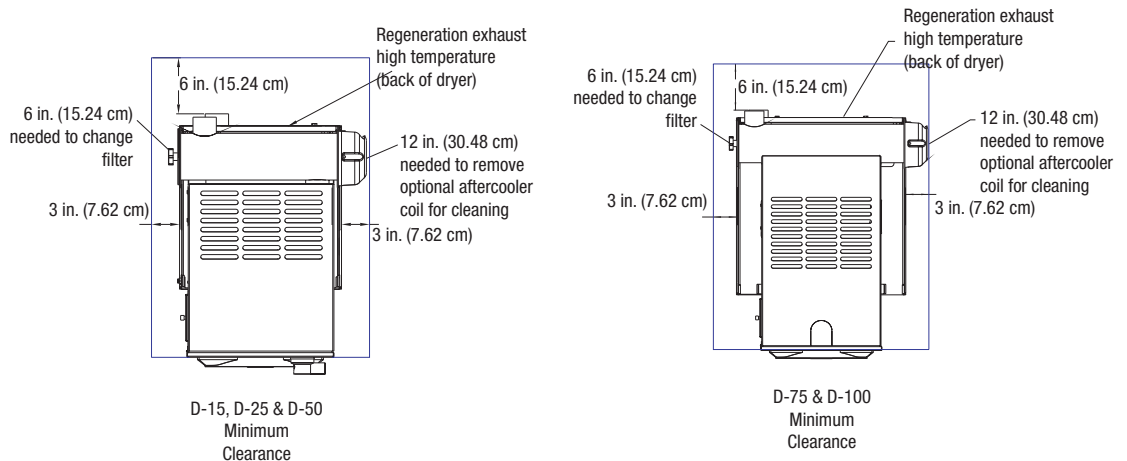

# Preparing for Installation (continued)

❑ **A mounting surface that will support the weight** of the dryer, support frame, and a fully-loaded hopper, or just the fully-loaded hopper. See the specifications tables for weights and volumes.

❑ **Material and conveying lines installed.** If you plan to use vacuum or compressed air loaders to fill the hopper, install conveying lines to the drying hopper location.



**NOTE:** If your mounting surface does not match the standard bolt patterns available, you will need an adapter. You can make an adapter using the dimensions provided or purchase one from Conair.

## 2 Drill and tap mounting holes or make adapter.

Available discharge assemblies and slide gates fit mounting surfaces with these bolt patterns and diameters.

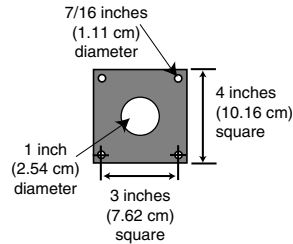
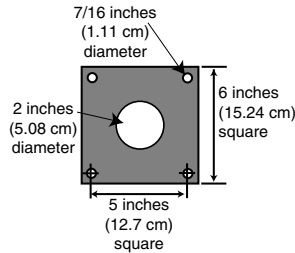

# Mounting the Dryer and Hopper on a Processing Machine

 **WARNING:** You are responsible for the structural integrity of this installation.

We recommend that you:

- Use bolts no smaller than 3/8 inch (M 10) when mounting the hopper/dryer combination to the throat of a processing machine.
- Do not mount the hopper/dryer combination on a plate that swings away or slides away from the processing machine throat. Either remove the swing or slide plate, position the dryer on the floor, or mount the dryer to an optional floor stand.

## ***Tools for installation:***

- Flathead screwdriver
- 9/16" and 1/2" wrench
- Hoist

 **NOTE:** You must position the dryer on the floor or mount it to an optional floor stand if your processing machine throat requires the small discharge assembly or a mounting plate with less than a 3 x 3 in. (7.6 x 7.6 cm) bolt pattern and 1 in. (2.54 cm) diameter opening.

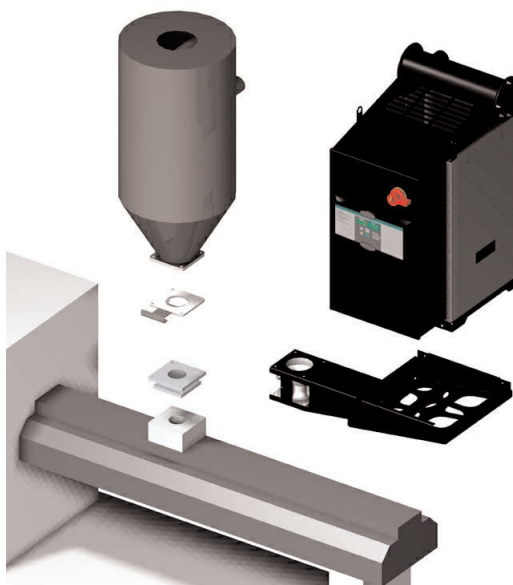

The dryer and hopper mount on a support frame / discharge assembly that bolts to the throat of the processing machine, as pictured above.

 **CAUTION:** To prevent accident and injury, lift the empty hopper and support frame onto the throat of the processing machine using a hoist and the lifting lugs provided. After the hopper is mounted, then lift the dryer onto the support frame using a hoist and the lifting lugs provided.

# Mounting the Dryer and Hopper on a Processing Machine (continued)

The drying hopper, slide gate, support frame, and discharge assembly may have been shipped fully assembled. You can remove the hopper from the support frame, if you find it easier to lift and bolt the frame and then the hopper to the throat of the processing machine.

**1 Lift the hopper, support frame, and discharge assembly onto the processing machine throat.** Use a hoist to lift the support frame and hopper. Position the frame and discharge assembly so that its bolt holes line up with the holes drilled in the throat. If hole patterns do not match, you can place a mounting adapter between the throat and the support frame.

**2 Bolt the frame and discharge assembly to the throat.** Using four 3/8 in. -16 (M 10) self-locking bolts, fasten the support frame and discharge assembly to the throat. The bolts must be long enough to reach at least 1/2 in. (1.25 cm) into the processing machine throat or mounting adapter after passing through the discharge assembly and support frame.

 **NOTE:** If you removed the hopper from the support frame, lift the hopper onto the frame using a hoist. Make sure the slide gate is positioned in the recess on the bottom of the hopper base plate. Align the bolt holes and fasten the base plate to the discharge assembly using the four 3/8 in. -16 (M 10) self-locking bolts provided.

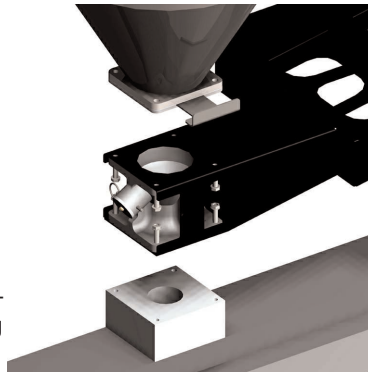

**3 Lift the dryer onto the support frame using a hoist and the lifting lugs provided.** Align the four bolt holes on the bottom of the dryer with the four bolt holes on the top of the support frame. Fasten the dryer to the frame with 5/16 in. -18 bolts.



# Positioning the Dryer on the Floor; Mounting the Hopper on the Throat



**WARNING:** You are responsible for the structural integrity of this installation.

We recommend that you:

- Use bolts no smaller than 3/8 in. (M 10) to mount the hopper on the throat of a processing machine.

## Tools for installation:

- 9/16" wrench
- Flathead screwdriver
- Hoist



The hopper bolts to the throat of the processing machine, as pictured above. The dryer can be positioned on the floor near the processing machine.

## Mounting the Hopper

**⚠ CAUTION:** To prevent accident and injury, lift the empty hopper onto the throat of the processing machine using a hoist and the lifting lugs provided. Also lift the dryer from the shipping container using a hoist and the lifting lugs provided.

**1 Lift the hopper onto the throat.** Lift the hopper with a hoist, using the lifting lugs provided. Make sure you align the bolt holes in the throat with the bolt holes on the discharge assembly.

**2 Bolt the hopper to the throat of the machine.** Using four 3/8 in.-16 (M 10) self-locking bolts, fasten the support frame, discharge, and slide gate to the throat. The bolts must be long enough to reach at least 1/2 in. (1.25 cm) into the mounting adapter or processing machine throat, after passing through the discharge and slide gate.

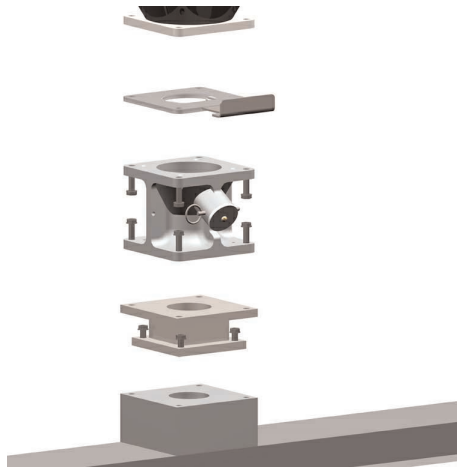

## Positioning the Dryer on the Floor

**1 Lift the dryer from the shipping container** using a hoist and the lifting lugs provided.

**2 Position the dryer on the floor** near the processing machine. Make sure the location allows for the connection of all hoses.

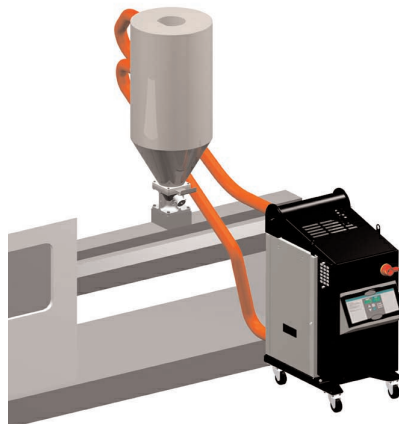

**NOTE:** Frame and casters are optional

## Mounting the Dryer on the Floor Stand; Hopper on the Throat

For information about mounting the dryer on the floor stand and the hopper on the throat, refer to Appendix B.

## Mounting the Dryer and Hopper on the Mobile Floor Stand

For information about mounting the dryer and hopper on the mobile floor stand, refer to Appendix B.

## Connecting the Main Power

 **CAUTION:** Always disconnect and lock out the main power sources before making electrical connections. Electrical connections should be made only by qualified personnel.

**1 Open the dryer's electrical enclosure.** Turn the disconnect dial on the dryer door to the Off or O position. Lock out the main power (see Page 1-4 for complete lock out information). Turn the captive screw, and swing the door open.

**2 Insert the main power wire** through the knockout in the side of the enclosure. Secure the wire with a rubber compression fitting or strain relief.

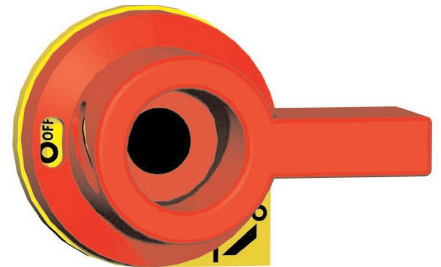

## Connecting the Main Power (continued)

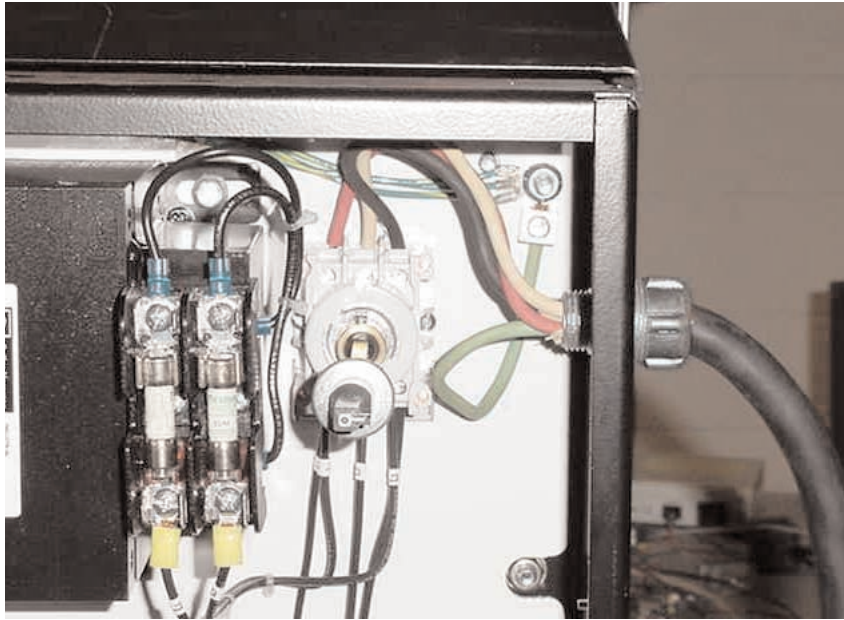

**IMPORTANT:** Always refer to the wiring diagrams that came with your dryer before making electrical connections.

- 3** Connect the power wires to the three terminals at the top of the power disconnect holder.
- 4** Connect the ground wire to either grounding point as shown in the photo.

# Checking for Proper Air Flow

This step is only needed on 50, 75, and 100 models.

 **CAUTION:** This step must be performed before the dryer's air hoses are connected to the hopper. Performing this step after the air hoses are connected could cause damage to the dryer if the air flow direction is incorrect due to improper phase connection. **Material from the hopper can be pulled into the process heater, causing permanent damage.**

- 1 Turn on the main power to the dryer.** Make sure the dryer's disconnect dial is in the ON position. This powers up the control and the display lights will illuminate.
- 2 Set the drying temperature to a low setpoint (or below 150°F).** Press Setpoint Adjust ▲ or ▼ buttons to set the temperature.

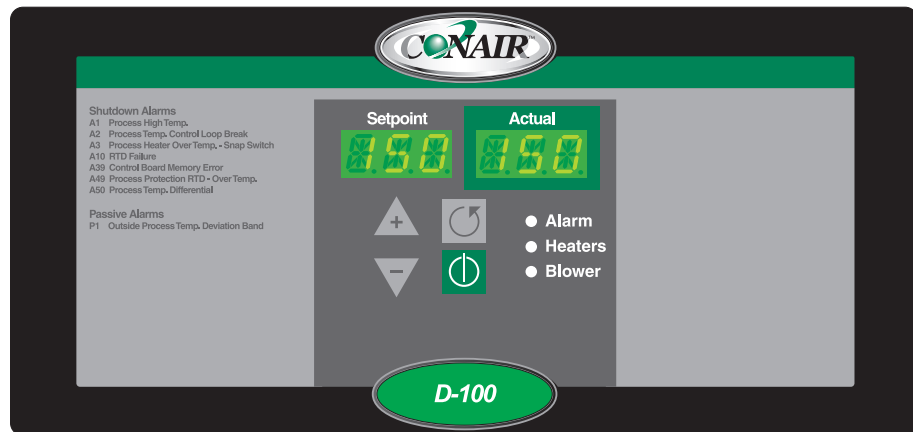

## Checking for Proper Air Flow (continued)

**3** When the dryer is stopped, press the  button to **START**.  
Hold your hand near the delivery air outlet. You should feel air blowing out of the outlet.

**4** When the dryer is running, press the  button to **STOP**.

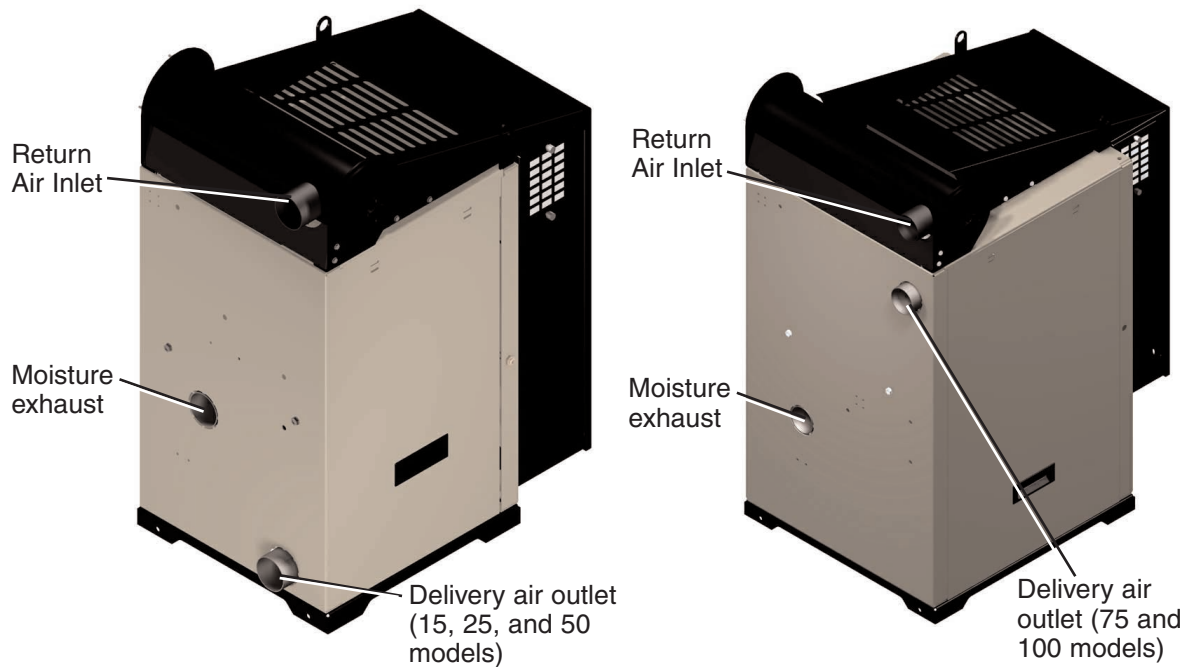

**CAUTION: Hot surface** Do not place your hand on the delivery air outlet. The outlet and the air can get hot enough to burn your hand.

## Checking for Proper Air Flow (continued)



 **INSTALLATION NOTE: Models 50, 75, and 100**

These models use a three-phase process blower. If the dryer shuts down and a Process Loop Break shutdown alarm is indicated within the first few minutes of operation, check for proper air flow.



If the air flow is reversed, the process blower is turning in the wrong direction. Turn off and lock out the main power source. Open the electrical enclosure and reverse any two leads connecting the main power supply to the dryer.

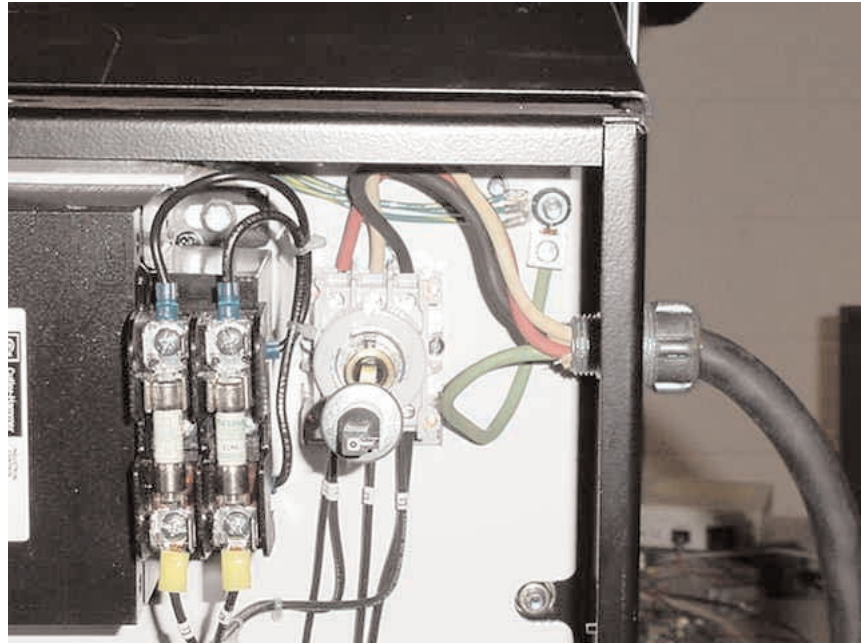

**WARNING:** All wiring, disconnects, and fuses should be installed by qualified electrical technicians in accordance with electrical codes in your region. Always maintain a safe ground. Do not operate the equipment at power levels other than what is specified on the the machine serial tag and data plate.

# Connecting the Air Hoses

Using the two flexible hoses provided, connect the inlets and outlets of the drying hopper to the dryer. If you have positioned the dryer on the floor or mounted it to an optional floor stand, make sure the dryer is located no more than 5 feet (1.5 m) from the hopper to reduce heat loss.

If you ordered an insulated hose, it should be installed between the dryer outlet and the hopper inlet.

If you have ordered an optional aftercooler or precooler, see Appendices C and D.

- 1 Attach one hose** from the return air inlet of the dryer to the return air outlet of the hopper.
- 2 Attach one hose** from the delivery air outlet of the dryer to the delivery air inlet of the hopper.

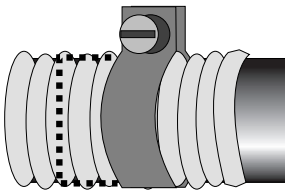
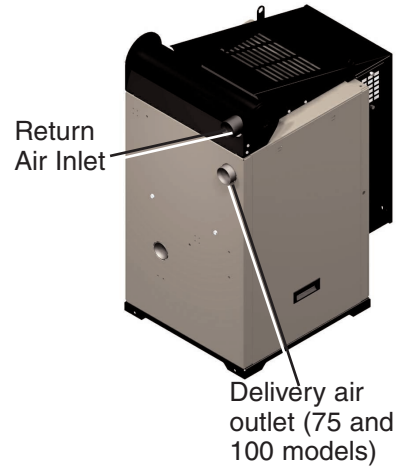

- 3 Secure hoses with clamps.** The hose clamp should be secured at least 1/4 in. (0.64 cm) from the end of the inlet or outlet tube.

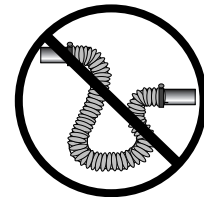

 **NOTE:** Do not allow the flexible hoses to kink or crimp.

# Connecting the Water Hoses

The optional aftercooler, and precooler require a source of cooling water and a discharge or return line. See Appendix C for information on installing and connecting water hoses to the optional aftercooler. See Appendix D for information on installing and connecting water hoses to the optional precooler.

# Connecting the RTD Probe

The RTD probe monitors the temperature of the drying air as it enters the hopper. If the probe is not installed correctly, temperature readings will be inaccurate.

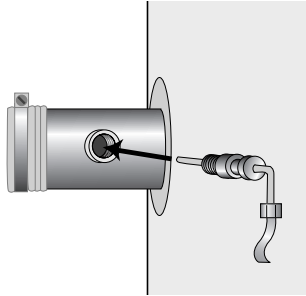

- 1 Insert the probe at the inlet to the hopper.** The end of the probe must not touch the walls of the inlet. The tip of the probe should be approximately in the center of the tube. Tighten the nuts to lock the probe in place.



- 2 Plug the probe's cable into the receptacle on the left side of the electrical enclosure.** Hand tighten the connector. Coil any excess cable and secure it with a wire tie.

## Mounting a Loader on the Hopper

If you have a Conair loader or vacuum receiver, you can use the flange and mounting clips provided on the top of the hopper. Refer to the manuals that came with your receiver or loader for detailed installation instructions.

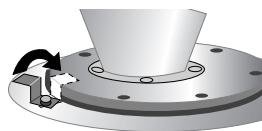

## Testing The Installation

You have completed the installation. Now it's time to make sure everything works.

- 1 Make sure there is no material in the hopper.** If you have mounted a loader or vacuum receiver on the hopper, disconnect the material inlet hose at the source.
- 2 Turn on the main power to the dryer.** Make sure the dryer's disconnect dial is in the ON position. This powers up the control and the display lights will illuminate.
- 3 Set the drying temperature.** Press the Setpoint Adjust ▲ or ▼ buttons to set the temperature.

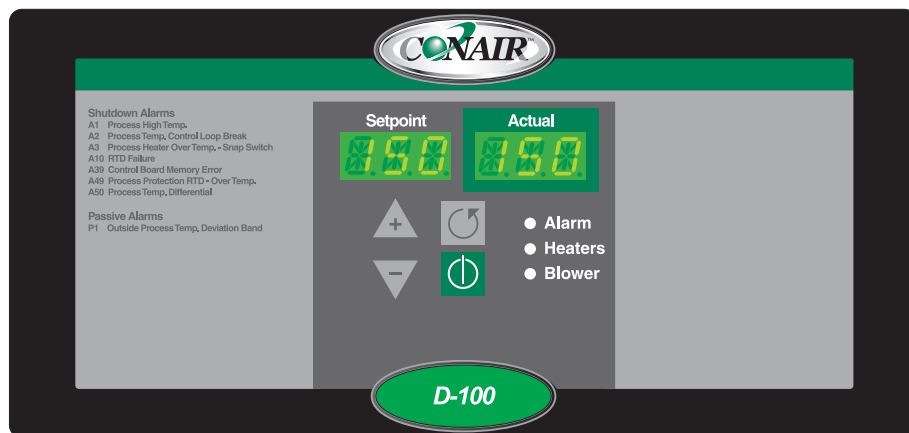
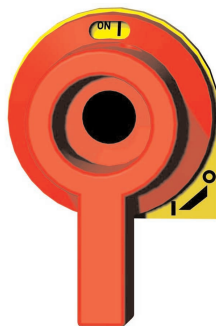

(continued)

## Testing The Installation (continued)

### 4 Press the button.

If everything is installed correctly:

- The heater and blower lights will illuminate.
- The process and regeneration blowers turn on.
- The process and regeneration heaters turn on.
- If the desiccant tanks are not in their correct position, the carousel will turn clockwise and stop in the correct position.

### 5 Press the button.



**NOTE:** Under an Alarm Condition, pushing the Start/Stop/Acknowledge Alarm button turns off the horn. Pushing the Start/Stop/Acknowledge Alarm button a second time turns off the alarm LED.

If everything is installed correctly:

- The blowers will continue running as needed to cool the heaters.

### 6 **The test is over.** If the dryer performed the normal operating sequences as outlined, you can load the hopper and begin operation. If it did not, refer to the TROUBLESHOOTING section of the User Guide.

---

## Operation

The DC dryer control panel . . . . .	4-2
D dryer DC control functions . . . . .	4-3
Control function flow chart . . . . .	4-3
Control function descriptions . . . . .	4-6
To start drying . . . . .	4-20
To stop drying . . . . .	4-20

# The DC Dryer Control Panel

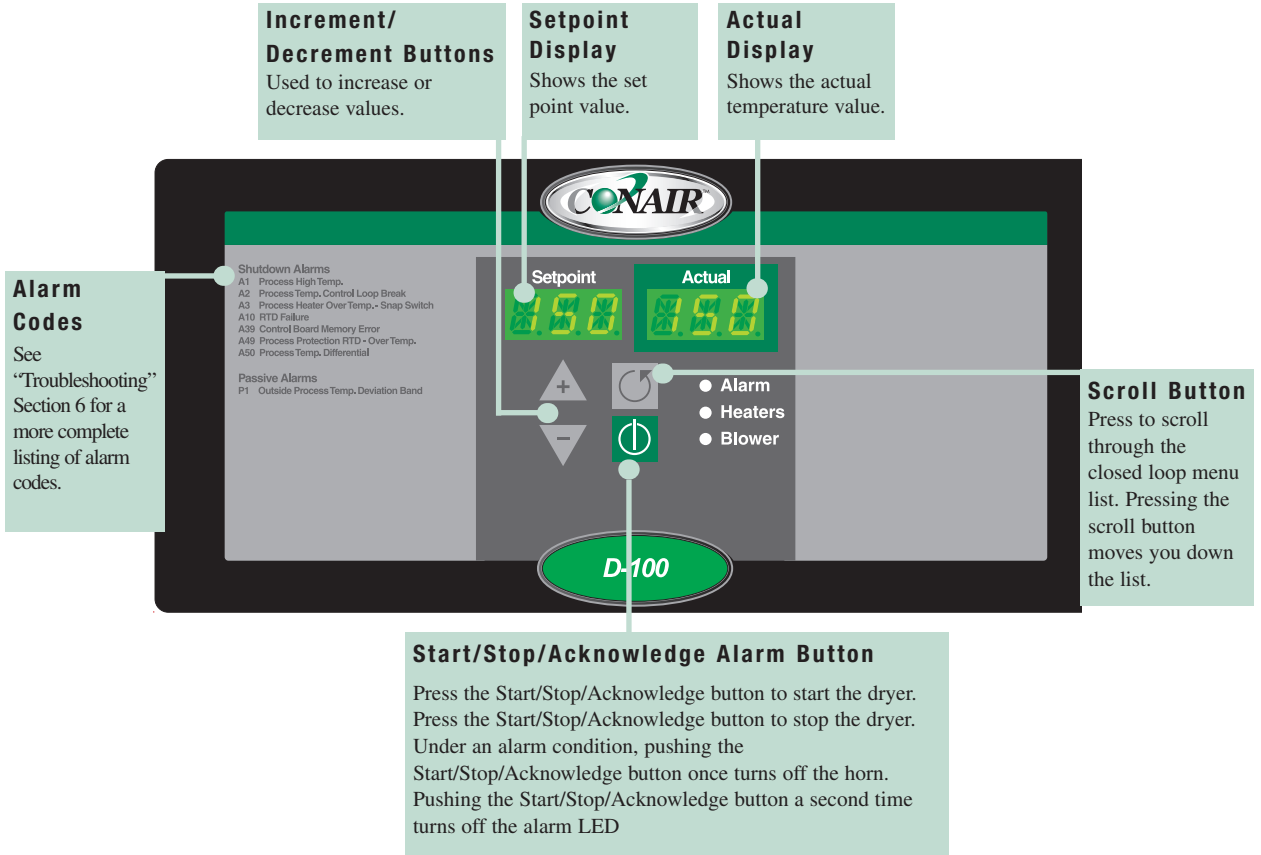

# D Dryer DC Control Functions

Dryer functions are values that you can set or monitor. Press the Scroll button until the function you want to set or monitor appears in the LED display.

## Control Function Flow Chart

The following flow chart provides a quick summary of the control functions. For an explanation of each control function, see Control Function Description.

## POWER ON

- 1 888 888 2 sec All LEDs On
- 2 dC 004 2 sec Software Version
- 3 dr yEr 2 sec Dryer

- (Default Screen) 4 250 250 Process Setpoint and Actual Temp (Default Screen)  
Press + or - to change setpoint.

- 5 Press Scroll Button  
for Process Deviation Alarm Setpoint (Dev)  
5 dEv + or - Deviation Band  
Press + or - to change setpoint.  
Press Scroll to enter the value

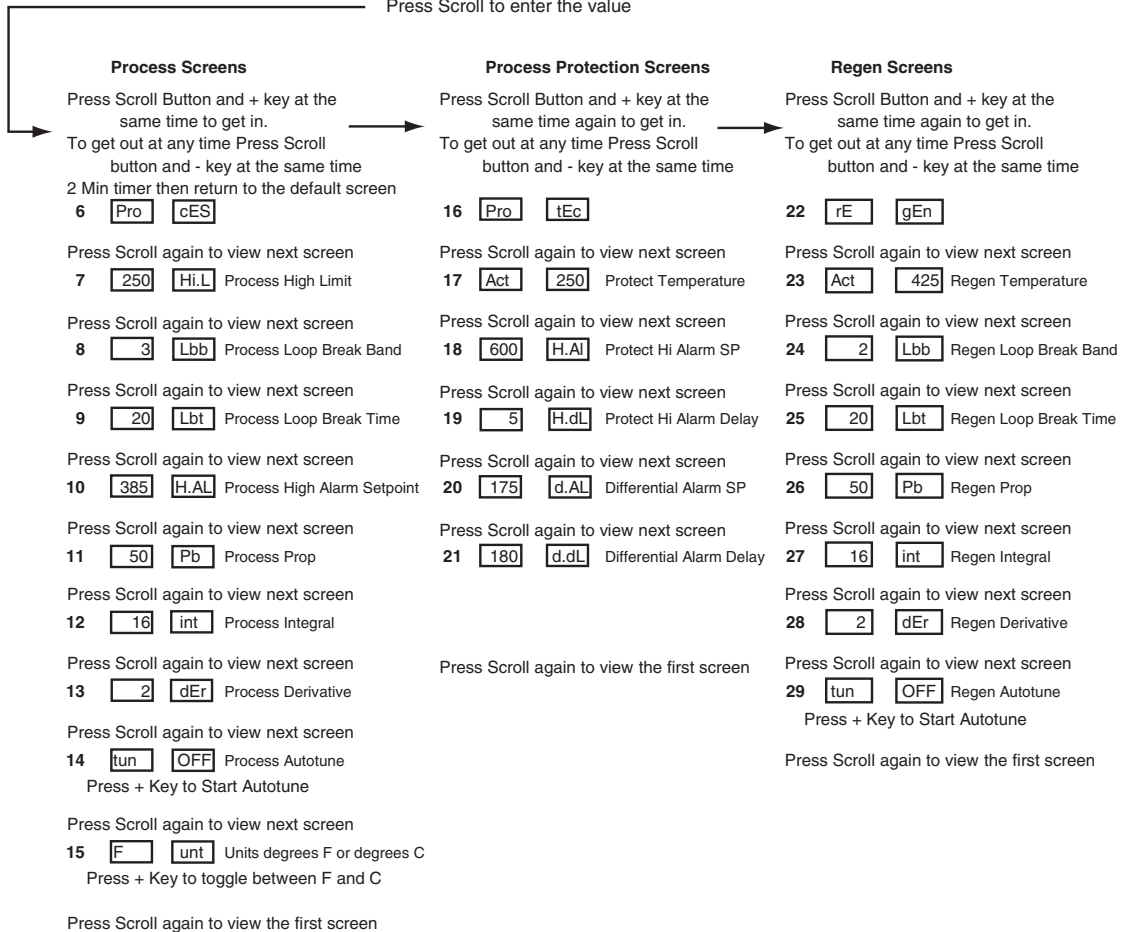

**Setup Screens**

Press **Scroll Button and + key at the same time for 10 seconds to get in.**

To get out at any time Press Scroll button and - key at the same time

30

Press Scroll again to view next screen

31   Controller Type

Press Scroll again to view next screen

32   Process Protection Install

Press Scroll again to view next screen

33   Goto Test Mode

Press Scroll again to view next screen

34   Load Default

Press + Key to Load Default

Press Scroll again to view the first screen

**Test Mode Screens**

\* The test mode screens become visible if tSt (screen 33) is turned on.

To get out at any time Press Scroll button and - key at the same time

35

Press Scroll again to view next screen

36   Digital Input 1

Press Scroll again to view next screen

37   Digital Input 2

Press Scroll again to view next screen

38   Digital Input 3

Press Scroll again to view next screen

39   Digital Input 4

Press Scroll again to view next screen

40   Press + key to jog output 1

Press Scroll again to view next screen

41   Press + key to jog output 2

Press Scroll again to view next screen

42   Press + key to jog output 3

Press Scroll again to view next screen

43   Press + key to jog output 4

Press Scroll again to view next screen

44   Press + key to jog output 5

Press Scroll again to view next screen

45   Press + key to jog output 6

# Control Function Descriptions

## General Screens

### SCREEN 1

888	888
-----	-----

### SCREEN 2

dC	004
----	-----

### SCREEN 3

dr	yEr
----	-----

### SCREEN 4

Setpoint	Actual
250	250

### SCREEN 5

10	dEv
----	-----

## Function

Once the power is turned on, this screen is displayed for 2 seconds while the control performs its self-checking process. All LEDs are illuminated during this 2-second interval.

After the self-checking process is complete, this screen flashes for 2 seconds and displays the software version.

After the software version is displayed, this screen appears for 2 seconds and identifies that the control is setup for a dryer.

This is the default screen. It shows the process air temperature setpoint and the actual temperature measured at the inlet to the drying hopper. The +/- buttons can be used to change the setpoint. Holding the +/- buttons in will cause the number to ramp up faster the longer the buttons is held. The display will return to the default screen from anyplace in the menu structure if nothing is done for 10 minutes.

This is the process deviation temperature alarm setpoint screen. It is used to set the deviation temperature band around the process temperature setpoint. The range is 5 - 20°F (2.5 - 10°C). The +/- buttons can be used to change the setpoint. If the dryer goes outside the band, the dryer will display a passive alarm (P1).

# Control Function Descriptions

## Process Screens Function

SCREEN 6

**Pro** **cES**

To access the process screens, press the Scroll and “+” buttons at the same time and hold for two seconds . To get out of the Process screens at any time, press the Scroll and “-“ buttons at the same time. After two minutes, you will be returned to the Default screen.

This is the process header screen. It indicates that all items below it pertain to the process temperature control.

SCREEN 7

**375** **Hi.L**

This is the process high limit screen. It is used to set the high limit for the process temperature. The +/- buttons can be used to change the setpoint. If set at 250° F, the operator cannot set the process setpoint above 250° F.

SCREEN 8

**3** **Lbb**

This is the process loop break band screen. It is used to set the temperature band for the loop break alarm. The +/- buttons can be used to change the setpoint.

SCREEN 9

**20** **Lbt**

This is the process loop break time screen. It is used to set the temperature band time for the loop break alarm. The +/- buttons can be used to change the temperature band time. This is how they work together: When the actual temperature is outside the deviation band, if the temperature is not moving toward the setpoint at a rate greater than or equal to X F over Y sec, then the dryer will alarm on loop break. Once the actual temperature is within the deviation band, the loop break is ignored.

## Control Function Descriptions (continued)

### Process Screens

SCREEN 10

**385** **H.AL**

SCREEN 11

**50** **Pb**

SCREEN 12

**16** **int**

SCREEN 13

**2** **dEr**

SCREEN 14

**tun** **OFF**

### Function

This is the process alarm high temperature setpoint screen. It is used to set the temperature at which the process high temperature shutdown alarm (A1) will shutdown the dryer and display the alarm. The +/- buttons can be used to change the setpoint.

This is the process proportional band screen. It is used to change the proportional band value for the process control loop. The +/- buttons can be used to change the proportional band setpoint.

This is the process integral screen. It is used to change the integral value for the process control loop. The +/- buttons can be used to change the integral value setpoint.

This is the process derivative screen. It is used to change the derivative value for the process control loop. The +/- buttons can be used to change the derivative value setpoint.

This is the process heater autotune screen. The autotune function can be turned on by pressing the "+" key. Once the "+" key is pressed, the screen will show "SEt" and then start the autotune process. Once heating starts, the screen will read "H.ru". Autotuning may take a minute or so to complete. When finished, the display will read "don". The new PID values are automatically saved.

# Control Function Descriptions (continued)

## Process Screens

SCREEN 15



## Function

This is the temperature units screen. It is used to change the temperature display from °F to °C or °C to °F.

# Control Function Descriptions (continued)

## Process Protection Screens

SCREEN 16



Protection

SCREEN 17



SCREEN 18



## Function

To access the process protection screens, press the Scroll and “+” buttons at the same time and hold for two seconds from the process screens. To get out of the Process protection screens at any time, press the Scroll and “-“ buttons at the same time.

This is the process protection header screen. It indicates that all items below it pertain to the process protection actual temperature and alarms.

This screen shows the process protection actual temperature.

This is the process protection high temperature alarm setpoint screen. If the actual process protection temperature exceeds this setpoint for the length of the process protection high alarm delay, this alarm (A49) will trigger and the dryer will shut-down. For example if the actual process protection temperature exceeds 600°F (316°C) for 10 seconds, the dryer will execute a shutdown alarm. The +/- buttons can be used to change the setpoint.

# Control Function Descriptions (continued)

## Process Protection Screens

SCREEN 19

10

H.dL

## Function

This is the process protection high alarm delay screen. It is used to set the delay time for the process protection high temperature alarm. If this time delay is exceeded, the dryer will execute a shutdown alarm (A49). The +/- buttons can be used to change the setpoint.

SCREEN 20

175

d.AL

This is the process differential alarm setpoint screen. If the actual process protection temperature minus the actual process temperature exceeds this setpoint for the length of the process differential alarm delay, this alarm (A50) will trigger and the dryer will shutdown. For example if the actual process protection temperature is 300°F (148.9°C) and the actual process temperature is 124°F (51.1°C) for 180 seconds, the dryer will execute a shutdown alarm. The +/- buttons can be used to change the setpoint.

SCREEN 21

180

d.dL

This is the process differential alarm delay screen. This screen is used to change the process differential alarm delay time. The +/- buttons can be used to change the setpoint.

## Control Function Descriptions (continued)

### Regeneration Screens

SCREEN 22



SCREEN 23



SCREEN 24



SCREEN 25



### Function

To access the regeneration (regen) screens, press the Scroll and "+" buttons at the same time and hold for two seconds from the process protection screens. To get out of the regeneration screens at any time, press the Scroll and "-" buttons at the same time.

This is the regen header screen. It indicates that all items below it pertain to the regen temperature control.

This screen shows the actual temperature of the regen air.

This is the regen loop break band screen. It can be used to set the temperature band for the loop break alarm. The +/- buttons can be used to change the temperature band setpoint.

This is the regen loop break time screen. It can be used to set the temperature band time for the loop break alarm. The +/- buttons can be used to change the temperature band time. Screens 24 and 25 are the regen loop break screens. This is how they work together: When the actual temperature is outside the deviation band, if the temperature is not moving toward the setpoint at a rate greater than or equal to X F over Y sec, then the dryer will alarm on loop break. Once the actual temperature is within the deviation band, the loop break is ignored.

# Control Function Descriptions (continued)

## Regeneration Screens

SCREEN 26

**50** **Pb**

SCREEN 27

**16** **int**

SCREEN 28

**2** **dEr**

SCREEN 29

**tun** **OFF**

## Function

This is the regen proportional band screen. It is used to change the proportional band value for the regeneration control loop. The +/- buttons can be used to change the proportional band setpoint.

This is the regen integral screen. It is used to change the integral value for the regeneration control loop. The +/- buttons can be used to change the integral value setpoint.

This is the regen derivative screen. It is used to change the derivative value for the regeneration control loop. The +/- buttons can be used to change the derivative value setpoint.

This is the regeneration heater autotune screen. The autotune function can be turned on by pressing the + key. Once the + key is pressed, the screen will show "SEt" and then start the autotune process. Once heating starts, the screen will read "H.ru". Autotuning may take a minute or so to complete. When finished the display will read "don". The new PID values are automatically saved.

## Control Function Descriptions (continued)

### Setup Screen

### Function

SCREEN 30



To access the setup screens, press the Scroll and "+" buttons at the same time and hold for ten seconds. To get out of the setup screens at any time, press the Scroll and "-" buttons at the same time.

SCREEN 31



This is setup header screen. It indicates that all items below it pertain to dryer setup functions.

SCREEN 32



The DC controller can be setup to control a dryer or a resin works heater. This should always be set to "dry" when used to control a dryer.

SCREEN 33



This screen states that process protection has been installed. This should always be set to "ON" when used to control a dryer.

SCREEN 34



This is the test screen. Press the "+" key to enter the test mode.

This is the load defaults screen. Pressing the "+" key will load all default values and setpoints. Once this is done all parameters must be reset.



**WARNING:** All setpoints revert back to the default values.

# Control Function Descriptions (continued)

## Test Mode Screens

SCREEN 35



SCREEN 36



SCREEN 37



SCREEN 38



## Function

To access the test mode screens, press "+" button when you are in the test screen. To get out of the test mode screens at any time, press the Scroll and "-" buttons at the same time.

This is the test mode header screen. It indicates that all items below it are test functions.

This screen shows the state of digital input 1. If the input is open, "OFF" will be displayed. If the input is closed, "ON" will be displayed. Digital input 1 on a dryer is the process high temperature switch. This switch is closed during normal operation. It opens when it detects a high temperature inside the process heater tube.

This screen shows the state of digital input 2. If the input is open, "OFF" will be displayed. If the input is closed, "ON" will be displayed. Digital input 2 on a dryer is the regen high temperature switch. This switch is closed during normal operation. It opens when it detects a high temperature inside the regen heater tube.

This screen shows the state of digital input 3. If the input is open, "OFF" will be displayed. If the input is closed, "ON" will be displayed. Digital input 3 on a dryer is the bedplate limit switch. This switch is open when the bedplate is in the drying position. This switch closes when the dryer is indexing.

## Control Function Descriptions (continued)

### Test Mode Screens

SCREEN 39

**in.4** **OFF**

SCREEN 40

**ou.1** **OFF**

SCREEN 41

**ou.2** **OFF**

SCREEN 42

**ou.3** **OFF**

### Function

This screen shows the state of digital input 4. If the input is open, "OFF" will be displayed. If the input is closed, "ON" will be displayed. Digital input 4 on a dryer is the process blower motor starter overload auxiliary contact. The contact is open during normal operation when the overload is not tripped. If an overload condition occurs, this contact closes and turns the input to "ON".

This is the output 1 screen. Press the "+" key to jog output 1. Output 1 on a dryer is the process and regen blowers. Pressing the "+" key for 2 seconds will cause the process and regen blowers to run.

This is the output 2 screen. Press the "+" key to jog output 2. Output 2 on a dryer is the bed drive motor. Pressing the "+" key will cause the dryer to index one position.

This is the output 3 screen. Press the "+" key to jog output 3. Output 3 on a dryer is the process heater solid-state relay signal. Pressing the "+" key will cause the process solid-state relays to fire. You can observe the solid-state relay LED to check this output. Since the isolation contactor is open, the heater does not come on because it does not have power.

# Control Function Descriptions (continued)

## Test Mode Screens

SCREEN 43

**ou.4** **OFF**

SCREEN 44

**ou.5** **OFF**

SCREEN 45

**ou.6** **OFF**

## Function

This is the output 4 screen. Press the "+" key to jog output 4. Output 4 on a dryer is the regen heater solid-state relay signal. Pressing the "+" key will cause the regen solid-state relays to fire. You can observe the solid-state relay LED to check this output. Since the isolation contactor is open, the heater does not come on because it does not have power.

This is the output 5 screen. Press the "+" key to jog output 5. Output 5 on a dryer is the process and regen heater power isolation contactor signal. Pressing the "+" key will cause the isolation contactor to close. Watch the isolation contactor pull in to check this output. Since the solid-state relays are not on, the heaters does not come on because they do not have power.

This is the output 6 screen. Press the "+" key to jog output 6. Output 6 on a dryer is the alarm horn. Pressing the "+" key will cause the alarm horn to sound.

# Dryer DC Control Alarms

## PASSIVE ALARMS

Passive alarms flash the alarm code and display process temperature until the alarm condition goes away, or it becomes a shutdown alarm.

Code	Description	Alarm LED
P1	Process Temperature Deviation	Blinking Red
P3	Regen Temperature Deviation	Blinking Red

## SHUTDOWN ALARMS

Shutdown alarms flash the alarm code and display process temperature. The dryer should stop when both process and regen temps are below 150°F (65.6°C) or after 10 minutes has passed (whichever occurs first), but should still flash the alarm code until the Start/Stop/Acknowledge Alarm button is pressed. If the alarm condition is still active the dryer cannot start, it will flash alarm code again. If the alarm condition is not active, the display should return to the normal default screen display and the dryer is ready to run.

Code	Description	Alarm LED
A1	Process High Temperature	Solid Red
A2	Process Temperature Loop Break	Solid Red
A3	Process Heater box High Temperature	Solid Red
A4	Regen Heater box High Temperature	Solid Red
A5	Carousel Index Too Long Alarm	Solid Red
A6	Carousel Index Failure	Solid Red
A10	RTD Integrity	Solid Red
A26	Regen High Temperature	Solid Red
A35	Regen Temperature Loop Break	Solid Red
A39	EEProm Write Error-Internal Control Board Problem	Solid Red
A49	Process Protection High Alarm	Solid Red
A50	Process Differential Alarm	Solid Red
A53	Process Blower Overload Alarm	Solid Red

# To Start Drying

- 1 Make sure there is material in the hopper.**
- 2 Turn on the main power to the dryer.** Make sure the dryer's disconnect dial is in the ON position. This powers up the control and the display lights will illuminate.
- 3 Set the drying temperature.** Press the Adjust Setpoint ▲ or ▼ buttons to select the temperature.

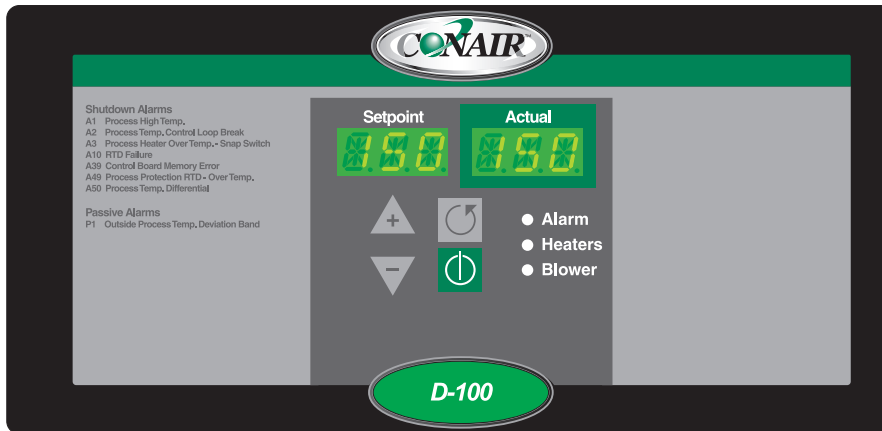

(continued)

## To Start Drying (continued)

**4** Press the  button.

If everything is installed correctly:

- The process and regeneration blowers turn on.
- The process and regeneration heaters turn on.
- If the desiccant tanks are not in their correct position, the carousel will turn clockwise and stop in the correct position.

## To Stop Drying

**1** Press the  button. The blower light stays on.

- The blowers continue running for a few minutes to cool the heaters.

**2** Be sure to disconnect and lockout the main power if you have stopped the dryer to perform maintenance or repair.

**IMPORTANT:** Do not use the main power switch to stop the dryer. Turning off power to the control and dryer during normal operation prevents the necessary cool-down period, and can trigger the shut down/high temperature alarm during your next drying cycle.



**Caution:** Improper shut down can cause damage to your dryer.

# Maintenance

---

Preventative maintenance checklist . . . . .	5-2
Cleaning the hopper . . . . .	5-3
Cleaning the process filter . . . . .	5-4
Cleaning the regeneration filter . . . . .	5-4
Cleaning the aftercooler coils . . . . .	5-5
Cleaning the precooler coils . . . . .	5-5
Inspecting hoses and gaskets . . . . .	5-5

# Preventative Maintenance Checklist

Routine maintenance will ensure optimum operation and performance of the D Carousel Dryer. We recommend the following maintenance schedule and tasks.

- **Whenever you change materials**

- Drain and clean the hopper.**

- **Weekly, or as often as needed**

- Clean the process and regeneration filters.**

You may need to clean filters more often than weekly. Frequency depends on how much material you process and how dusty or full of fines it is.

- Clean the return air screen in the hopper.**

Cleaning frequency depends on how much material you process and how dusty or full of fines it is.

- Inspect hoses and hose connections.**

Check for damage, kinks, or loose hose clamps. Replace any hoses that show signs of damage or wear. Reposition and tighten loose hose clamps.

- **Monthly**

- Clean the optional aftercooler and precooler coils.**

You may need to clean the coils more often than monthly. Frequency will depend on the type and volume of material you process.

- **Every six months**

- Inspect gaskets for damage or wear.**

Damaged gaskets can allow moisture to seep into the closed-loop drying system. Replace any gasket that is torn or cracked.

# Cleaning the Hopper



**CAUTION: Hot surfaces.** Always protect yourself from hot surfaces inside and outside the dryer and drying hopper.

The hopper, spreader cone, and discharge assembly should be cleaned thoroughly between material changes to prevent resin contamination.

Place a container beneath the hopper's drain port to catch the material.

**1 Close the hopper slide gate.**

**2 Remove the drain-port plug.** Pull the pin and allow the plug to drop. Open the slide gate and allow material to drain.



**3 Remove the spreader cone.** Open the hopper door. Reach into the hopper. Grasp the spreader cone tube, lift up slightly, twist and then push down to release it. Tilt the cone assembly and pull it out through the hopper door.



**4 Clean the spreader cone and the inside of the hopper.** Make sure you also clean the return air screen at the return air outlet of the hopper.

**5 Repeat the steps in reverse order** to reassemble the hopper before adding material.



# Cleaning the Process Filter



Clogged filters reduce air flow and dryer efficiency. Cleaning frequency depends on how much material you process and how dusty it is.



- 1 Remove the process filter.**  
Remove the black plastic knob. Remove the cap off. Remove the wing nut. Remove the filter cap and filter.
- 2 Clean the filter tube.**
- 3 Using compressed air, clean the process filter by blowing air from the inside out. Replace damaged, worn, or clogged filters.**



**CAUTION: Wear eye protection.** If you use compressed air to clean the equipment, **you must wear eye protection** and observe all OSHA and other safety regulations pertaining to the use of compressed air.

- 4 Reverse the procedure to reinstall the process filter.**

# Cleaning the Regeneration Filter



Clogged filters reduce air flow and dryer efficiency. Cleaning frequency depends on how much material you process and how dusty it is.

- 1 Remove the regeneration filter.**  
Remove the two bolts and the metal screen.
- 2 Clean the regeneration filter.** Clean dust, fines, and dirt from the filter, or replace it with a new filter.

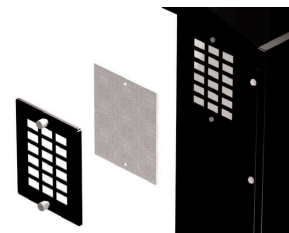

- 3 Reverse the procedure to reinstall the regeneration filter.**

## Cleaning the Aftercooler Coils

If you have the optional aftercooler, you need to clean the cooling coils to keep them working efficiently. See Appendix C for details.

## Cleaning the Precooler Coils

If you have the optional precooler, you need to clean the cooling coils to keep them working efficiently. See Appendix D for details.

## Inspecting Hoses and Gaskets

Loose or damaged hoses and gaskets can allow moisture to seep into the closed-loop drying system.

- 1 Follow the hose routing of all the hoses within the dryer and inspect all hoses, clamps, fittings, and gaskets.**
- 2 Tighten any loose hose clamps or fittings.**
- 3 Replace worn or damaged hoses and gaskets.**



# Troubleshooting

---

Before beginning . . . . .	6-2
A few words of caution . . . . .	6-3
<b><u>DIAGNOSTICS</u></b>	
How to identify the cause of a problem . . . . .	6-4
Shut down alarms . . . . .	6-5
Passive alarms . . . . .	6-10
<b><u>REPAIR</u></b>	
Replacing fuses . . . . .	6-11
Checking heater solid state relays . . . . .	6-12
Checking or replacing temperature sensors . . . . .	6-13
Adjusting the limit switch . . . . .	6-14
Replacing the heaters . . . . .	6-15
Replacing the desiccant tanks. . . . .	6-19
Refilling the desiccant tanks . . . . .	6-20

# Before Beginning

You can avoid most problems by following the recommended installation and maintenance procedures outlined in this User Guide. If you do have a problem, this section will help you determine what caused it and how to fix it.

**Before you take the side panels off of the dryer be sure to:**

**Diagnose causes from the control panel.**

**1** Press  once to silence the optional audible alarm and display the alarm message.

**2** Address the alarm message and fix the problem.

**3** Press  again to clear the alarm. If the alarm reappears the problem was not fixed.

If the alarm is a **passive alarm** you will see **P** in the screen title display.

If the alarm is a **shut down alarm** you will see **A** in the screen title display.

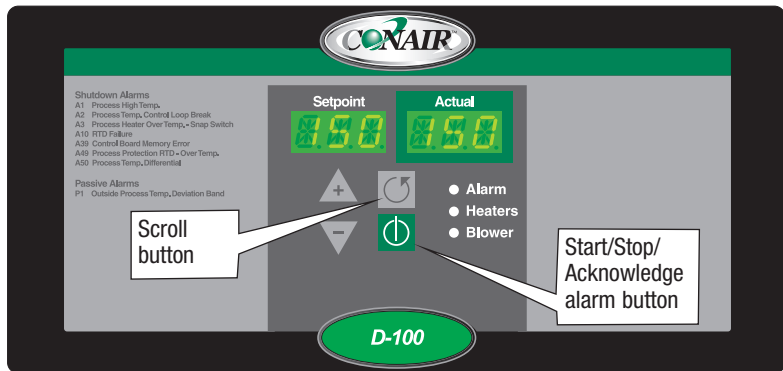

**Diagnose causes from the front of the dryer.**

You can identify any problem from the front of the dryer.

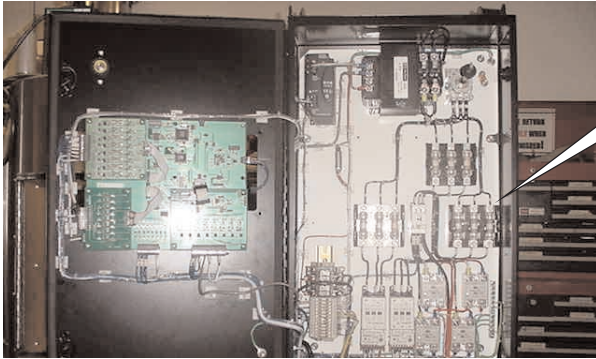

Open the electrical enclosure to check fuses and heater contactors.

 **Note:** Picture only representative of the dryer. Yours may not look exactly the same.

❑ **Find the wiring and equipment diagrams that were shipped with your dryer.** These diagrams are the best reference for correcting a problem. The diagrams also will note any custom features, such as special wiring or alarm capabilities, not covered in this User Guide.

## A Few Words of Caution

The D Carousel dryer is equipped with numerous safety devices. Do not remove or disable them. Improper corrective action can lead to hazardous conditions and should never be attempted to sustain production.

 **WARNING:** Only qualified service personnel should examine and correct problems that require opening the dryer's electrical enclosure or using electrical wires to diagnose the cause.

 **WARNING:** High voltage. Always stop the D Carousel dryer, disconnect and lock out the main power source before troubleshooting or performing repairs.

 **CAUTION:** Hot surfaces. Always protect yourself from hot surfaces inside and outside of the dryer and hopper.

# How to Identify the Cause of a Problem



Most dryer malfunctions are indicated by an illuminated Acknowledge Alarm light on the D carousel dryer control panel.

**A problem can trigger two types of alarms:**

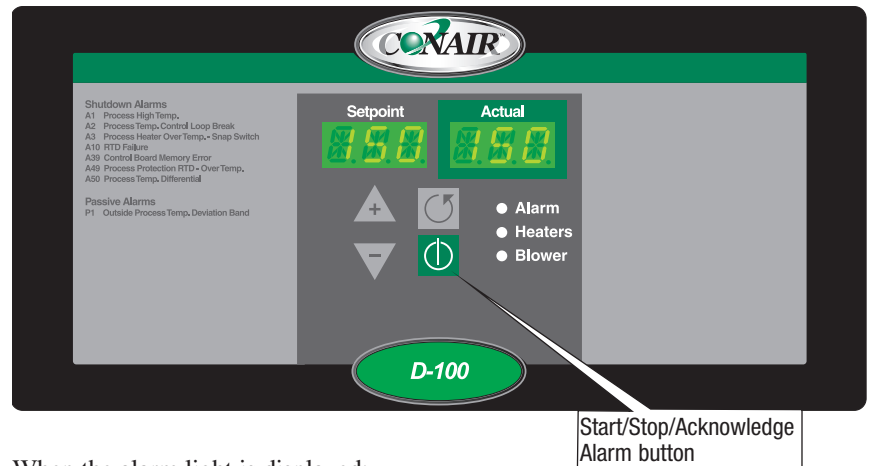
- **Shut Down:** The dryer has automatically shut down because it detected a serious problem that could damage your material or dryer.
- **Passive:** The dryer continues to operate, but warns of a problem that could prevent correct drying of your material. If ignored, this problem could lead to a condition that will shut down the dryer.



When the alarm light is displayed:

- 1 Press the  button once to silence the optional audible alarm and display the alarm message.**  
Pressing the Acknowledge Alarm button once also changes the alarm LED from blinking to solid.
- 2 Find the error message in the diagnostics table of this troubleshooting section.**
- 3 Note that pressing the  button a second time will clear the alarm.**

# Shut Down Alarms

If the red Acknowledge Alarm LED is solid, the alarm is a shutdown alarm. The dryer will shutdown automatically to prevent damage to the equipment or personnel.

## Problem

**A1** Process High Temperature – If the process temperature exceeds the process high temperature setpoint, it shuts down the dryer. Defaults are set to 385°F (196.1°C) for 20 sec.

**A2** Process Temperature Loop Break – If the process temperature is outside of the operator entered deviation, alarm band (see Process High Temperature Deviation passive alarm) and the process temperature is not moving towards the setpoint at a rate greater than specified. It shuts down the dryer. Defaults are set at 3°F (1.7°C) over 20 sec.

**A3** Process Heater High Temperature – The snap switch in the process heater tube opens due to excessive temperature.

## Possible cause

The RTD temperature probe is not installed correctly.

The air lines are restricted or loose.

Process RTD is loose or has fallen out.

The process heater has failed.

The air lines are restricted or loose.

There is an air flow blockage or loose hoses.

The isolation contactor failed in the closed position.

The heater solid state relays (SSRs) failed.

## Solution

Make sure the RTD temperature probe tip is in the center of the hopper inlet tube.

Straighten any crimps in the hoses. Tighten any loose hoses.

Check the process RTD and tighten if needed.

Check the heater fuses, and resistance across each leg of the process heater.

Straighten any crimps in the hoses. Tighten any loose hoses.

Check that the bed plates are in the proper position (lined up with the hoses).

Tighten any loose hoses.

Replace the isolation contactor.

Replace the failed heater solid state relays (SSRs).

# Shut Down Alarms

## Problem

**A4** Regen Heater High Temperature – The snap switch in the regeneration heater tube activated due to excessive temperature.

**A5** Carousel Index Too Long Alarm – If the carousel index was more than 1.5 times the normal index time, it shuts down the dryer.

**A6** Carousel Index Failure – If the carousel index is requested but no contact transition from on to off is seen within 5 sec, it shuts down dryer.

## Possible cause

The regeneration exhaust is blocked or the air hoses are loose.

The isolation contactor failed in the closed position.

The heater solid state relays (SSRs) failed.

The limit switch is not adjusted correctly.

The limit switch is not adjusted correctly.

The bed drive motor is damaged.

The set screw on the bed drive motor shaft plate is loose.

The bed drive motor relay has failed.

## Solution

Check that the bed plates are in the proper position (lined up with the hoses). See “*Adjusting the limit switch*”.

Tighten any loose hoses.

Replace the isolation contactor.

Replace the failed heater solid state relays (SSRs).

Adjust the limit switch so that it drops into the groove and stops the bed plates. See “*Adjusting the limit switch*”.

Adjust the limit switch so that it drops into the groove and stops the bed plates.

Replace the bed drive motor.

Tighten the set screw. Make sure it is on the flat of the D shaped shaft.

Replace the bed drive motor relay.

# Shut Down Alarms

## Problem

**A10** RTD Integrity – If the process RTD is faulty

**A26** Regen High Temperature – If the regeneration temperature exceeds the high temperature limit for the specified time. Default values are 450°F (232.2°C) for 20 sec.

**A35** Regen Temperature Loop Break – The regeneration temperature is outside of the operator entered deviation alarm band (see Regen Temperature Deviation passive alarm) and the regeneration temperature is not moving towards the setpoint at a rate greater than specified. Default values are 2°F (1°C) over 40 sec.

**A39** EEPROM Write Error

## Possible cause

The connection in the electrical enclosure for the process RTD is loose.

The connection of the RTD plug on the control board is loose.

The process RTD has failed.

One of the solid state relays (SSRs) failed in the closed position.

The regeneration RTD is loose or has fallen out.

The regeneration heater has failed.

The regeneration RTD is loose or has fallen out.

Internal Control board problem.

## Solution

Check the RTD plug connection and tighten if needed.

Check the plug connection and tighten if needed.

Replace the process RTD.

Replace the failed solid state relays (SSRs).

Check the regeneration RTD and tighten if needed.

Check the heater fuses, and resistance across each leg of the process heater.

Check the regeneration RDT and tighten if needed.

Replace the Control board.

# Shut Down Alarms

## Problem

**A49** Process Protection High Temperature – If the process protection temperature exceeds the process protection high temperature setpoint, it shuts down the dryer. Defaults are set to 600°F (315.6°C) for 10 sec.

**A50** Process Protection Differential Temperature – If the process protection differential temperature exceeds the process protection differential temperature setpoint, it shuts down the dryer. Defaults are set to 175°F (97.2°C) for 180 sec.

## Possible cause

The Process RTD temperature probe is not installed correctly.

The air lines are restricted or loose.

The Process RTD temperature probe is not installed correctly.

The air lines are restricted or loose.

## Solution

Make sure the RTD temperature probe tip is in the center of the hopper inlet tube.

Straighten any crimps in the hoses.  
Tighten any loose hoses.

Make sure the RTD temperature probe tip is in the center of the hopper inlet tube.

Straighten any crimps in the hoses.  
Tighten any loose hoses.

# Shut Down Alarms

## Problem

**A53** Process Blower Overload – The process blower overload has tripped due to a mechanical or electrical problem.

## Possible cause

The process blower has mechanically failed or is unable to rotate freely.

The process blower has failed electrically.

The overload is set incorrectly.

## Solution

With the power removed, check the process blower for mechanical failure and free rotation. Replace if necessary. Wait 3 to 15 minutes with the power on until the dryer indicates the overload condition has cleared then try to restart the dryer.

With the power removed, check the process blower for electrical shorts or open circuits. Replace if necessary. Wait 3 to 15 minutes with the power on until the dryer indicates the overload condition has cleared then try to restart the dryer.

With the power removed, check the overload settings and confirm that the settings match the full load amps listed on the process blower motor (110% of FLA). Wait 3 to 15 minutes with the power on until the dryer indicates the overload condition has cleared then try to restart the dryer.

## Passive Alarms

If the red Acknowledge Alarm LED is blinking, the alarm is a passive alarm. The dryer continues to operate, but this problem could prevent correct drying of your material. Note that once the Acknowledge Alarm button is pressed once, the blinking red LED becomes solid.

### Problem

**P1** Process Temperature Deviation – The process temperature exceeds the deviation band as entered for the specified time. Default values are 10°F (6°C) for 5 sec.

**P3** Regen Temperature Deviation – The regeneration temperature exceeds the deviation band for the specified time. Default values are 10°F (6°C) for 5 sec.

### Possible cause

One of the solid state relays (SSRs) failed in the closed position.

The process RTD is loose or has fallen out.

The air hose connections are loose.

One of the solid state relays (SSRs) failed in the closed position.

The regeneration RTD is loose or has fallen out.

The air hose connections are loose.

### Solution

Replace the failed solid state relays (SSR).

Check the process RTD and tighten if needed.

Tighten all air hose connections.

Replace the failed solid state relays (SSRs).

Check the regeneration RTD and tighten if needed.

Tighten all air hose connections.

# Replacing Fuses

**1** Disconnect and lockout the main power supply.



**2** Open the electrical enclosure door.

**3** Check the fuse. If necessary, pull the fuse out and replace it with a fuse of the same type and rating.



**IMPORTANT:** Always refer to the wiring diagrams that came with your dryer to locate specific electrical components. Illustrations in the User Guide are intended to be representative only.

## Fuse Blocks

To locate the appropriate fuse and replacement part, refer to the wiring diagrams that came with your dryer.

# Checking Heater Solid State Relays



**1** Disconnect and lockout the main power supply.



**2** Open the electrical enclosure.

**3** Locate the process or regeneration relays. Refer to the wiring diagrams that came with your dryer.

**4** Check continuity using an ohmmeter.

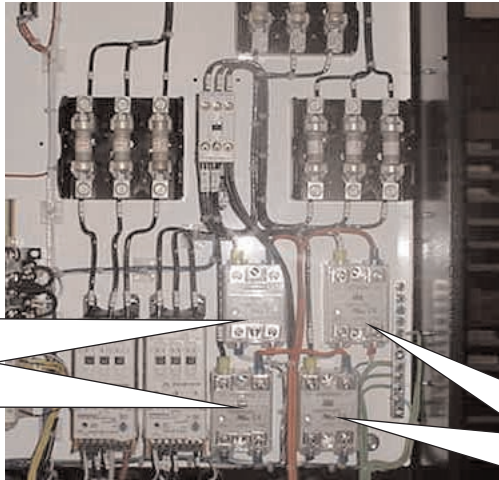

**Regeneration heater solid state relays**

If ohms equal zero or infinity, replace the solid state relay.

**Process heater solid state relays**

If ohms equal zero or infinity, replace the solid state relay.

**IMPORTANT:** Always refer to the wiring diagrams that came with your dryer to locate specific electrical components. Illustrations in the User Guide are intended to be representative only.

# Checking or Replacing Temperature Sensors

The D carousel dryer uses RTD sensors to monitor the temperatures of the drying air, the regeneration air, and the heater box process protection.



Location of the Process RTD at the Hopper



**IMPORTANT:** Always refer to the wiring diagrams that came with your dryer to locate specific electrical components. Illustrations in the User Guide are intended to be representative only.

To check or replace an RTD sensors:

- 1 Disconnect and lockout the main power supply.**
- 2 Remove dryer panels, as necessary.**
- 3 Locate the RTD sensors.**
- 4 Check the sensor positions and conditions.** Temperature readings will be incorrect, if the sensors are touching the wall of an air hose or pipe or if the sensor or wiring is damaged. The tip of the sensor should be centered within the air hose or pipe. Sensor wires should be attached to the appropriate connection points on the dryer's electrical enclosure or microprocessor board.
- 5 To check with ohm meter** - measure the resistance across the RTDs. The resistance should be approx. 110 ohm at room temperature.
- 6 Replace the sensor, if necessary.**



# Adjusting the Limit Switch



**1 Stop the dryer. Disconnect and lockout the main power.** 

**2 Remove the right side panel from the dryer.** 

**IMPORTANT:** Note the position of the tanks.

**3 Loosen the screws securing the limit switch to the carousel.** Note that the hole for the front screw is slotted to allow for adjustment.

**4 Slide the switch to the left or right** to position the limit switch so that its small roller drops into the valley on the bed plate. The roller on the switch should not hit the stationary bottom plate.

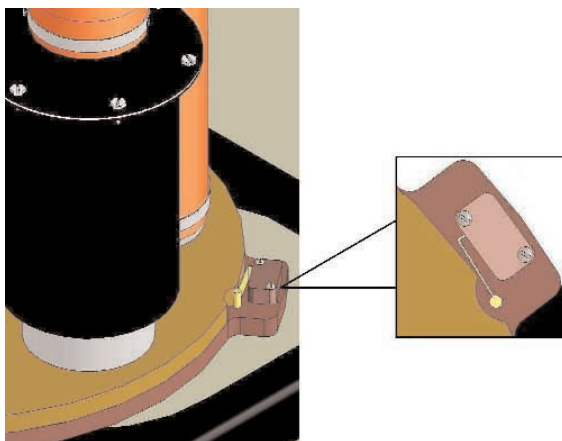

**5 Test for correct indexing of the carousel.** Restore main power to the dryer. With the dryer powered, but not started you can engage the limit switch and the carousel will turn. Once the bed plate starts turning, release the switch.

If everything is adjusted correctly:



- The carousel bed turns.
- When the limit switch reaches the next valley in the bed plate, the carousel should stop turning.

**6 Reset the desiccant carousel.**

Continue indexing until the desiccant tanks return to the positions they were in when the dryer shut down.

# Replacing the Heaters

## Regeneration Heater

- 1 Disconnect and lockout the main power at the power source.** 
- 2 Open the electrical enclosure door.**
- 3 Reference the wiring diagram and / or trace the wires from the regeneration heater tube into the control box.** Remove the wires from the relays and terminal strips. Once disconnected, pull the wires from the control box into the dryer housing toward the heater tube.
- 4 Gain access to the regeneration heater** by removing the right dryer side panel. 
- 5 Remove the hose and hose clamp** at the bottom of the heater tube.
- 6 Remove the insulation from the heater tube** by cutting the insulation in a straight line from top to bottom.
- 7 Remove the small 1/8" (3.18 mm) plastic hose from the hose barb, and remove the hose barb.** Save the barb, it will need to be installed in the new heater tube.
- 8 Remove and save the regeneration RTD and fitting.** They will be installed in the new heater.
- 9 Remove the heater tube by twisting the tube counterclockwise.** The tube is threaded into the lower bed plate. You may need to use a pipe wrench or chain wrench to remove it.
- 10 Check the ID mark on the side of the heater tube for kW rating and voltage.** The ID mark is on the outside of the tube near the end with the lead wires. Make sure the kW and voltage is the same as the replacement heater.
- 11 Thread the new heater into the lower bed plate.** The RTD should be pointing directly toward the back of the dryer. Do not over tighten. Hand tighten, and use a wrench for no more than one turn to get RTD into the correct position. 

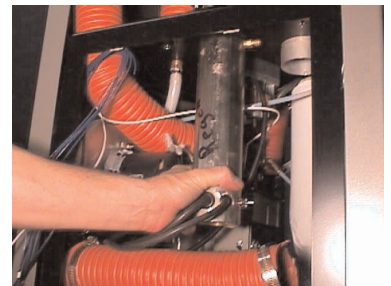

**Note:** When installed the regeneration heater tube must be oriented so the RTD is directly toward the back of the dryer.

# Replacing the Heaters

## Regeneration Heater (continued)

**12** Install the RTD fitting and RTD in the 1/8" (3.18 mm) NPT hole toward the top of the heater tube.

**13** Put the insulation back on. Make sure to duct tape the seam that was cut during removal.

**IMPORTANT:** The distance the RTD extends into the heater is critical for proper functioning. The distance from the metal heater tube to the outside surface of the curve on the RTD must be 2.5" (63.5 mm) (see photo). To take the measurement, peel back (but do not remove) any existing insulation to access the metal heater tube.

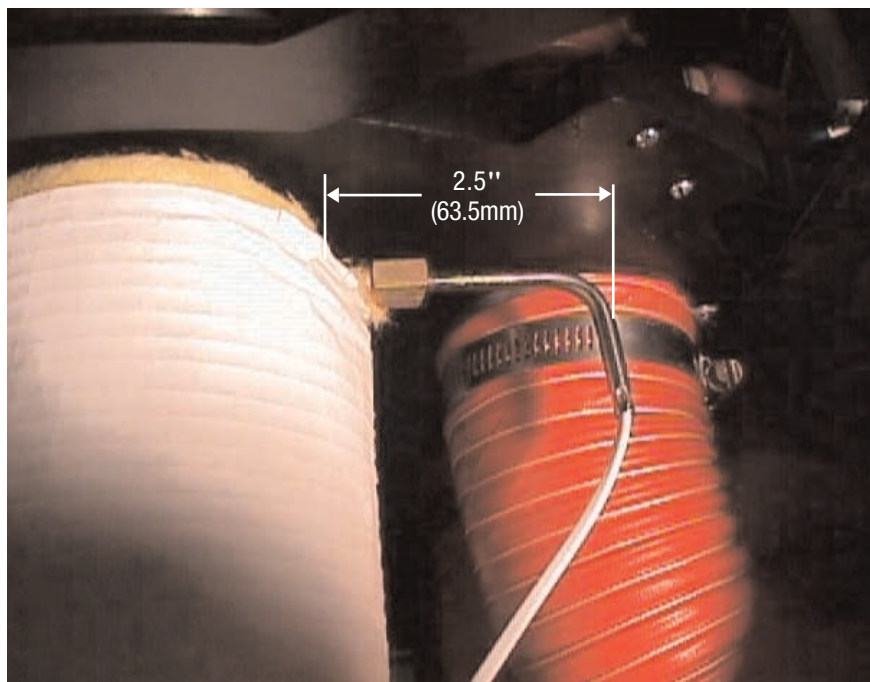

**14** Put the hose barb back in the lower 1/8" (3.18 mm) NPT hole and connect the plastic hose.



**15** Reattach the lower 2-1/2" (63.5 mm) hose and hose clamp.

**16** Put petroleum jelly on the tips of the new heater wire leads to make it easier to go through the holes in the back of the control box. Reference the wiring diagram to re-attach the heater wires and the two snap switch wires.

**17** Make sure the heater fuses are not blown before trying the new heater.

# Replacing the Heater

## Process Heater

- 1 Disconnect and lockout the main power** at the main power source. 
- 2 Open the electrical enclosure door.**
- 3 Reference the wiring diagram and / or trace the wires** from the process heater tube into the control box. Remove the wires from the relays and terminal strips. Once disconnected, pull the wires from the control box into the dryer housing toward the heater tube.
- 4 Gain access to the process heater** by removing the left dryer side panel. 

### For D15, D25, and D50 Dryers

- 5 Remove the hose and hose clamp at the bottom of the heater tube.**
- 6 Remove the insulation from the heater tube** by cutting the insulation in a straight line from top to bottom.
- 7 Remove the plugs or hose fittings** toward the top end of the heater. These will need to be installed on the new heater.
- 8 Remove the heater tube by twisting the tube counterclockwise.** The tube is threaded into the lower bed plate. You may need to use a pipe wrench or chain wrench to remove the heater.
- 9 Check the ID mark on the side of the heater tube** for kW rating and voltage. The ID mark is on the outside of the tube near the end with the lead wires. Make sure the kW and voltage is the same as the replacement heater.
- 10 Thread the new heater into the lower bed plate.** The lead wires should be pointing toward the inside of the dryer. Do not over tighten. Hand tighten then use a wrench for no more than one turn to put the lead wires into the correct position.
- 11 Put the insulation back on.** Make sure to duct tape the seam that was cut during removal.

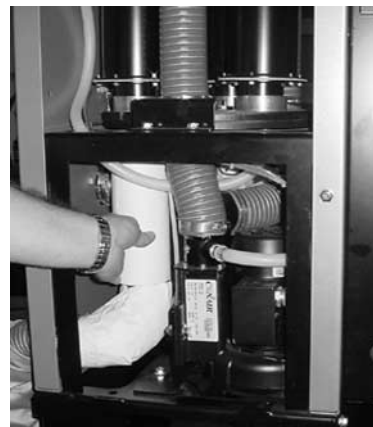

◆ **TIP:** Depending on the model and the mounting configuration selected for the dryer installation, it may be necessary to access the process heater through the right side panel or to remove the process blower to create adequate access to use a wrench to remove the process heater. See Removing the Process Blower.

**Note:** When installed, the process heater tube must be oriented so the power wires are toward the inside of the dryer.

# Replacing the Heater

## Process Heater (continued)

- 12 Reinstall the plugs or hose fittings** into the holes near the top end of the heater tube.
- 13 Reattach the lower 2-1/2" (63.5 mm) hose and hose clamp.**
- 14 Put petroleum jelly on the tips of the new heater wire leads** to make it easier to go through the holes in the back of the control box. Reference the wiring diagram to reattach the heater wires and the two snap switch wires.
- 15 Make sure the heater fuses are not blown** before trying the new heater.

## For D75 and D100 Dryers





- 5 Remove the hose clamp holding the heater tube to the dryer frame.**
- 6 Remove the insulation from the heater tube** by cutting the insulation in a straight line from top to bottom.
- 7 Remove the hose and clamps** at the top and bottom of the heater tube.
- 8 Remove the plugs or hose fittings** toward the top end of the heater. These will need to be installed on the new heater.
- 9 Remove the heater from the dryer.**
- 10 Check the ID on the side of the heater tube for kW rating and voltage.** The ID mark on the outside of the tube near the end with the lead wires. Make sure the kW and voltage is the same as the replacement heater.
- 11 Insert the heater in the dryer.**
- 12 Reinstall the plugs or hose fittings** toward the top of the heater tube.
- 13 Reattach the lower 2-1/2" (63.5 mm) hose and clamps** to the top and bottom.
- 14 Put the insulation back on.** Make sure to duct tape the seam that was cut during removal.
- 15 Install the hose clamp holding the heater tube** to the dryer frame.
- 16 Put petroleum jelly on the tips of the new heater wire leads** to make it easier to go through the holes in the back of the control box. Reference the wiring diagram to reattach the heater wires and the two snap switch wires.
- 17 Make sure the heater fuses are not blown** before trying the new heater.

# Replacing the Desiccant Tanks

The D Carousel Dryer has refillable desiccant tanks. When desiccant becomes clogged or contaminated, you should replace the desiccant in all three tanks to ensure optimum performance, or purchase new, prefilled tanks from Conair.



**IMPORTANT:** It's important that the new tanks are connected to the correct hoses. Mark the hoses as they are disconnected, or replace one tank at a time, to ensure that you install the new tanks in the correct positions.

- 1 Stop the dryer then disconnect lockout the main power.** 
- 2 Remove both side panels from the dryer.** 
- 3 Disconnect the hose from the desiccant tank.** Loosen the hose clamp with a screw driver.
- 4 Lift the tank off the carousel assembly.** If using new, proceed to #7.
- 5 Refill the tank with fresh desiccant.**  
*See "Refilling the Desiccant Tank (Section 6).*
- 6 Check the O-rings in the carousel coupling.** Replace any O-rings that are cracked, worn, or damaged. Apply petroleum jelly on the inside of the coupling around the O-ring.
- 7 Place the refilled tank on the carousel assembly.** Make sure the inlet/outlet tube of the tank seats fully into the O-rings on the carousel pipe.
- 8 Connect the hose to the top of the tank.** Secure with the hose clamp.
- 9 Reinstall the side panel.**

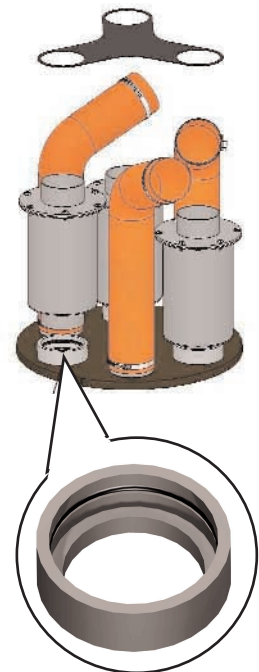
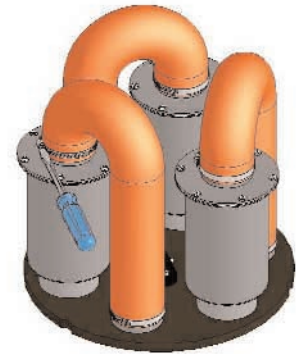

# Refilling the Desiccant Tanks

When desiccant becomes clogged or contaminated, you should replace the desiccant in all three tanks to ensure optimum performance.

**1 Remove the desiccant tank from the carousel.**

*See “Replacing Desiccant Tanks.”*

**2 Remove the tank end plate.**

Remove the six 10-32 self-tapping screws from the end plate.

**3 Remove the screen cap.**

Remove the two 1/4-20 nuts from the center post and pull the screen cap out.



**4 Remove the old desiccant.**

**5 Replace the gasket on the flange, if necessary.**

**6 Fill the tank with fresh desiccant.**

Fill the tank with the weight of desiccant indicated in the following table.

Model	Desiccant Weight
15 & 25	1 lb. (0.37 kg)
50	2 lb. (0.75 kg)
75	3 lb. (1.12 kg)
100	4 lb. (1.49 kg)

## Refilling the Desiccant Tank (continued)

- 7 Vibrate the tank for 15 minutes. (Important, no further settling can occur.)**
- 8 Reinstall the screen cap.** Place the cap on the band. Install one of the 1/4-20 nuts on the center post and tighten. Do not over-tighten. Install the second 1/4-20 nut and tighten.
- 9 Reinstall the tank end plate.** Place the end plate on the tank and tighten the six 10-32 screws.

**IMPORTANT:** After filling with fresh desiccant, vibrate the tank for at least 15 minutes.



- 10 Shake the tank beside your ear.** If properly filled, you will not be able to hear any desiccant rattling in the tank.
- 11 Reinstall the desiccant tank on the carousel.** See “*Replacing Desiccant Tanks.*”



## We're Here to Help

Conair has made the largest investment in customer support in the plastics industry. Our service experts are available to help with any problem you might have installing and operating your equipment. Your Conair sales representative also can help analyze the nature of your problem, assuring that it did not result from misapplication or improper use.

**Additional manuals and prints for your Conair equipment may be ordered through the Customer Service or Parts Department for a nominal fee.**

## How to Contact Customer Service

To contact Customer Service personnel, call:



From outside

the United States, call: 814-437-6861

You can commission Conair service personnel to provide on-site service by contacting the Customer Service Department. Standard rates include an on-site hourly rate, with a one-day minimum plus expenses.

## Before You Call...

**If you do have a problem, please complete the following checklist before calling Conair:**

- Make sure you have all model, control type from the serial tag, and parts list numbers for your particular equipment. Service personnel will need this information to assist you.
- Make sure power is supplied to the equipment.
- Make sure that all connectors and wires within and between control systems and related components have been installed correctly.
- Check the troubleshooting guide of this manual for a solution.
- Thoroughly examine the instruction manual(s) for associated equipment, especially controls. Each manual may have its own troubleshooting guide to help you.
- Check that the equipment has been operated as described in this manual.
- Check accompanying schematic drawings for information on special considerations.

## Equipment Guarantee

Conair guarantees the machinery and equipment on this order, for a period as defined in the quotation from date of shipment, against defects in material and workmanship under the normal use and service for which it was recommended (except for parts that are typically replaced after normal usage, such as filters, liner plates, etc.). Conair's guarantee is limited to replacing, at our option, the part or parts determined by us to be defective after examination. The customer assumes the cost of transportation of the part or parts to and from the factory.

## Performance Warranty

Conair warrants that this equipment will perform at or above the ratings stated in specific quotations covering the equipment or as detailed in engineering specifications, provided the equipment is applied, installed, operated and maintained in the recommended manner as outlined in our quotation or specifications.

Should performance not meet warranted levels, Conair at its discretion will exercise one of the following options:

- Inspect the equipment and perform alterations or adjustments to satisfy performance claims. (Charges for such inspections and corrections will be waived unless failure to meet warranty is due to misapplication, improper installation, poor maintenance practices or improper operation.)
- Replace the original equipment with other Conair equipment that will meet original performance claims at no extra cost to the customer.
- Refund the invoiced cost to the customer. Credit is subject to prior notice by the customer at which time a Return Goods Authorization Number (RGA) will be issued by Conair's Service Department. Returned equipment must be well crated and in proper operating condition, including all parts. Returns must be prepaid.

Purchaser must notify Conair in writing of any claim and provide a customer receipt and other evidence that a claim is being made.

## Warranty Limitations

**Except for the Equipment Guarantee and Performance Warranty stated above, Conair disclaims all other warranties with respect to the equipment, express or implied, arising by operation of law, course of dealing, usage of trade or otherwise, including but not limited to the implied warranties of merchantability and fitness for a particular purpose.**

# Mounting the Dryer on a Floor Stand



**Caution:** to prevent accident and injury, lift the dryer onto the floor stand using a hoist and lifting lugs provided.

- 1 Lift the dryer onto the floor stand.** Lift using a hoist and the lifting lugs provided.
- 2 Align the four bolt holes on the bottom of the dryer** with the four bolts holes on the top of the floor stand.
- 3 Bolt the dryer to the stand** using the four 5/16"-18 bolts provided.

## Tools for installation:

- 3/8" and 9/16" wrench
- Hoist

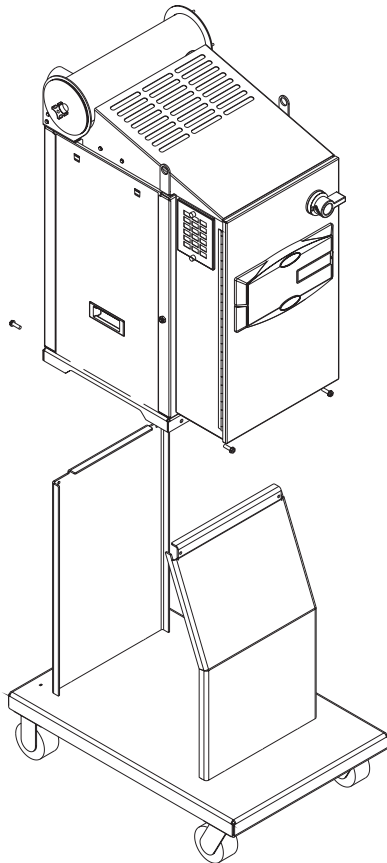

# Mounting the Dryer and Hopper on a Mobile Floor Stand



**CAUTION:** To prevent accident and injury, lift the empty hopper and the dryer onto the mobile floor stand using a hoist and the lifting lugs provided.

## Tools for installation:

- 5/32" Allen wrench
- 3/8" and 9/16" wrench
- Phillips screwdriver
- Flathead screwdriver
- Hoist and strap

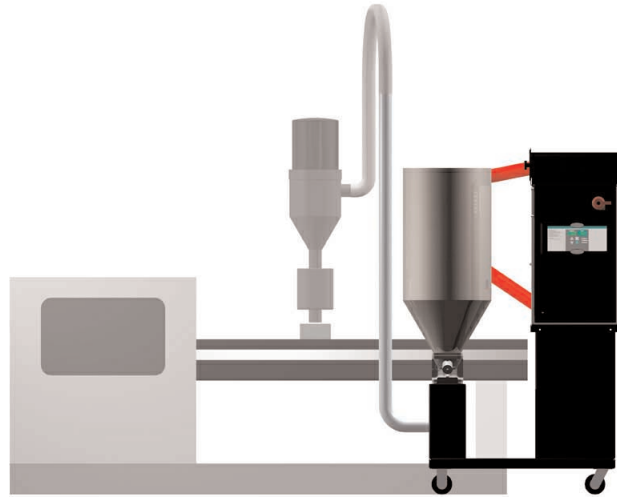

- 1** Lift the hopper onto the mobile floor stand using a hoist and the lifting lugs provided. Make sure you align the bolt holes in the mobile floor stand with the bolt holes on the discharge assembly.

(continued)

# Mounting the Dryer and Hopper on a Mobile Floor Stand (continued)

- 2 Bolt the hopper to the mobile floor stand.**  
Using four 3/8"-16 (M 10) self-locking bolts, fasten the hopper to the mobile floor stand.



- 3 Lift the dryer onto the mobile floor stand** using a hoist and lifting lugs provided.
- 4 Align the four bolt holes** on the bottom of the dryer with the four bolts holes in the mobile floor stand stand.
- 5 Bolt the dryer to the mobile floor stand** using the four 5/16"-18 self-locking bolts provided.



## Installing an Aftercooler (Optional)

You can add an aftercooler to the D Carousel Dryer by ordering the optional aftercooler assembly. Installation is easy.

The optional aftercooler requires a source of city, tower, or chiller water and a discharge or return line. You can use water at temperatures up to 85°F (30°C). But the water flow should be at least 1 gal/min (3.8 liters/min) for models D15, D25, D50; or 2 gal/min (7.6 liters/min) for models D75 and D100.

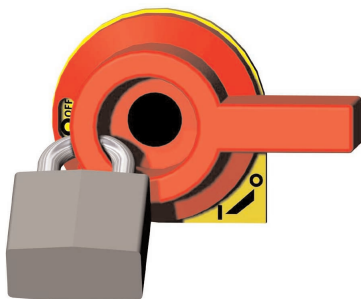

• **TIP:** Make the water supply and discharge / return connections with flexible hoses at least 24 in. (61 cm) long. This allows you to easily remove the aftercooler assembly for cleaning.

**1 Stop the dryer and lockout the main power.**



**2 Remove the cover plate** from the right side of the aftercooler housing on the dryer by removing the five nuts.

**3 Inspect the condition of the gasket.** If the gasket is damaged, replace the gasket.

**4 Insert the aftercooler assembly into the aftercooler housing.** Make sure the staggered holes in the aftercooler mounting plate align with the holes in the aftercooler housing.

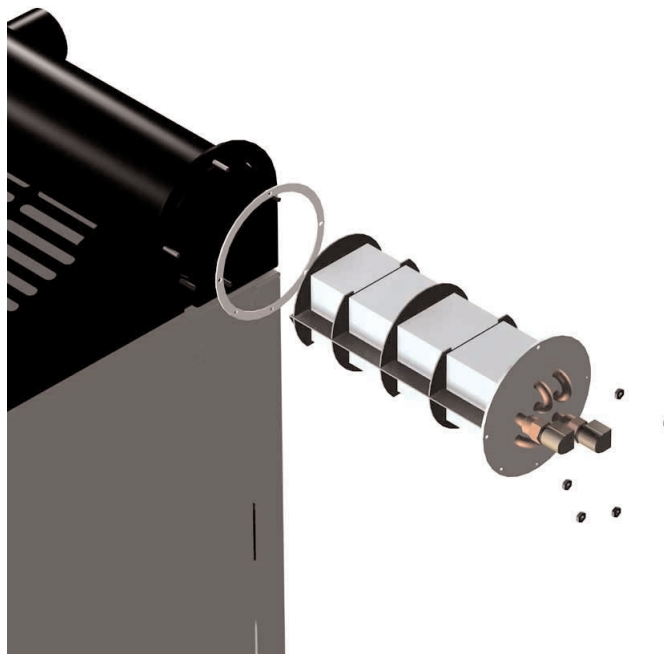

# Installing an Aftercooler (Optional)

(continued)

- 5** Secure the aftercooler assembly in the aftercooler housing using the five screws.
- 6** Connect the water supply line to the aftercooler inlet. If a manual shut off valve is used, it should be mounted on the inlet line.
- 7** Connect the water discharge or return line to the aftercooler outlet.

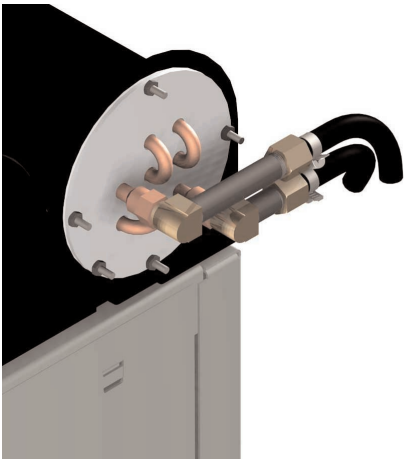

- 8** Install the plastic aftercooler cap over the water connections, using the nuts removed in step 2.



## Cleaning the Aftercooler

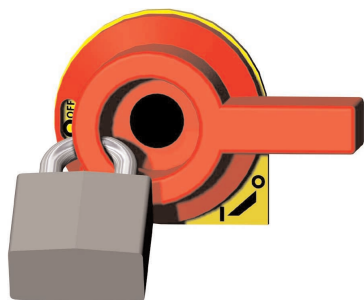

If you have the optional aftercooler, you need to clean the aftercooler coils to keep them working efficiently. Cleaning frequency depends on the type and amount of material you process.

**1 Stop the dryer and lockout the main power.**



**2 Turn off the water flow to the water supply line.** Disconnect supply and return lines.

**3 Remove the plastic aftercooler cover.**



**4 Remove the five nuts securing the aftercooler** in the aftercooler housing.

•❖ **TIP:** If the aftercooler (without a flow control) was installed using the recommended 24 in. (61 cm) of flexible hoses, there is no need to disconnect the hoses from the aftercooler inlet and outlet unless they are taking it to another location for cleaning.

(continued)

## Cleaning the Aftercooler (continued)

- 5 Remove the aftercooler assembly from the aftercooler housing.

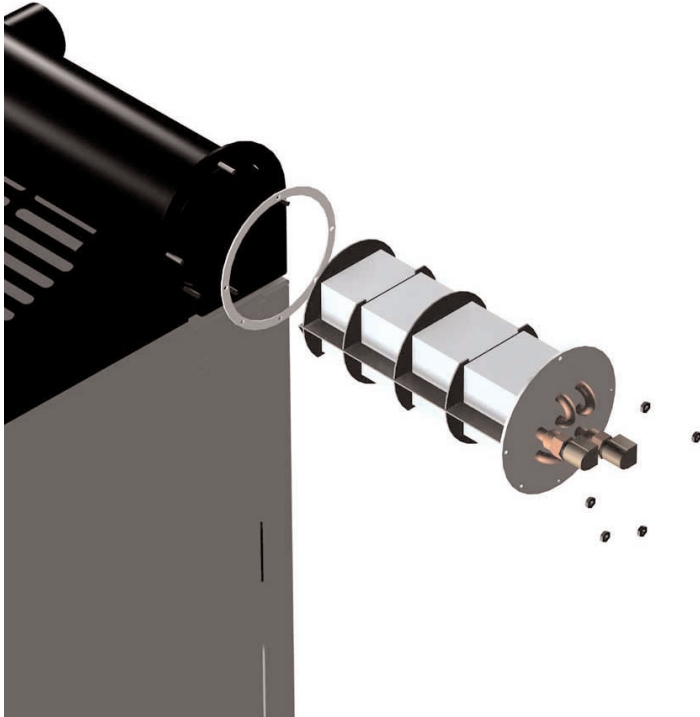

- 6 Clean the aftercooler assembly using a mild soap and water. Let the aftercooler dry thoroughly before installation.



**CAUTION:** During the cleaning process, **DO NOT** cut or remove the stainless steel wire that holds the aftercooler assembly together.

- 7 Inspect the condition of the gasket. If it is damaged, replace the gasket.
- 8 Reassemble by repeating the steps in reverse order.

(continued)

## Cleaning the Aftercooler *(continued)*

- 9** Connect the water supply line to the aftercooler / precooler inlet. If a manual shut off valve is used, it should be mounted on the inlet line as well.
- 10** Connect the outlet of the aftercooler / precooler to the inlet of the flow control valve using the pre-shaped copper tubing and compression fittings provided.
- 11** Install the plastic aftercooler/precooler cover.

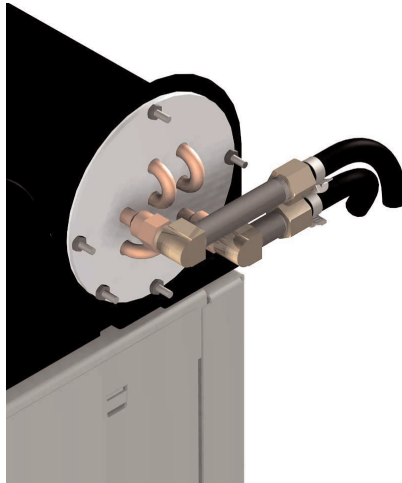

## Installing a Precooler (Optional)

You can add a precooler to the D Carousel Dryer by ordering the optional precooler assembly. Installation is easy.

The optional precooler requires a source of city, tower, or chiller water and a discharge or return line. You can use water at temperatures up to 85°F (30°C). But the water flow should be at least 1 gal/min (3.8 liters/min) for models D15, D25, D50; or 2 gal/min (7.6 liters/min) for models D75 and D100.

**1 Stop the dryer and lockout the main power.** 

**2 Remove the left dryer side panel.**

**3 Mount the precooler to the back of the dryer** using existing holes and the 5/16-8 bolts provided. Note that for D 15, 25, and 50 models, the precooler is mounted to the dryer with the water fittings and precooler air outlet at the top. On D 75 and 100 models, the precooler is mounted with the water fittings and precooler air outlet at the bottom.



**4 Connect the process air outlet hose to the precooler air inlet tube** and tighten the clamp provided.

**5 Connect the hopper air inlet air hose to the precooler air outlet tube** and tighten the clamp provided.

 **Note:** It is strongly recommended that a customer-supplied manual flow control valve be installed on the water inlet line.

**6 Connect the water supply line to the precooler inlet.** If a manual shut off valve is used, it should be mounted on the inlet line.

 **TIP:** Make the water supply and discharge / return connections with flexible hoses at least 24 in. (61cm) long. This allows you to easily remove the precooler assembly for cleaning.

(continued)

## Installing a Precooler (Optional)

(continued)

- 7** Connect the water discharge or return line with the pressure relief valve to the precooling outlet. Use the bracket supplied to secure the pressure relief valve and discharge line to the back of the dryer.



Precooler installed on a D 15, 25, and 50 dryer without a flow control

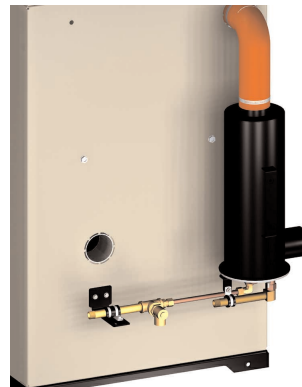

Precooler installed on a D 75 and 100 dryer without a flow control

**IMPORTANT:** For drying setpoint temperatures above 150°F (65.6°C), the pre-cooler must be bypassed by connecting the dryer supply hose from the dryer directly to the hopper inlet.

- 8** Install the plastic pre-cooler cap over the water connections.

# Cleaning the Precooler

If you have the optional precooler, you need to clean the precooler coils to keep them working efficiently. Cleaning frequency depends on the type and amount of material you process.

**1 Stop the dryer and lockout the main power.**



**2 Turn off the water flow to the water supply line.** Disconnect supply and return lines.



**3 Remove the plastic precooler cover.**

**4 Remove the five screws securing the precooler assembly in the precooler housing.**

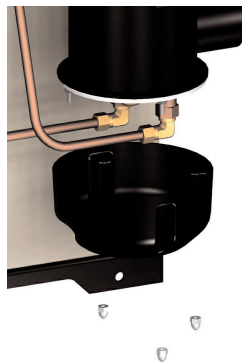
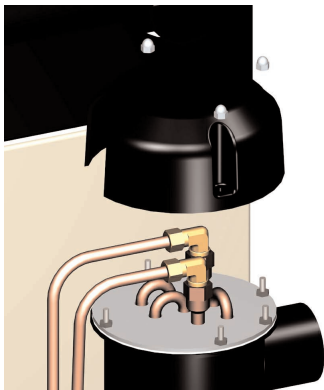

(continued)

## Cleaning the Precooler (continued)

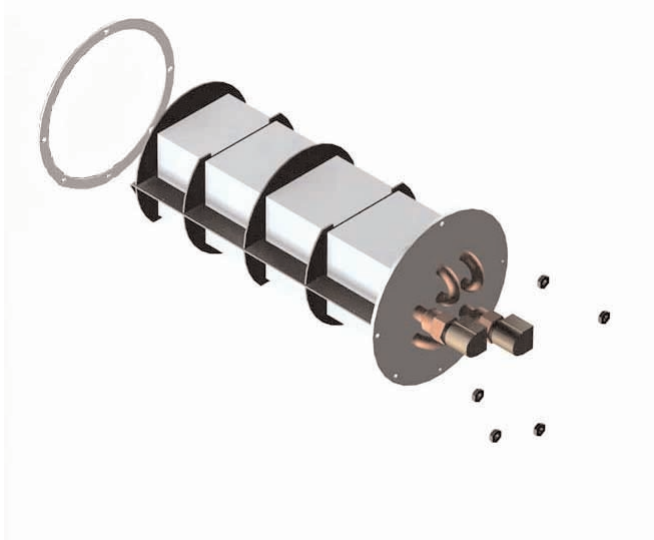

- 5** Remove the precooling assembly from the precooling housing.
- 6** Clean the precooling assembly using a mild soap and water. Let the precooling dry thoroughly before installation.
-  **CAUTION:** During the cleaning process, DO NOT cut or remove the stainless steel wire that holds the precooling assembly together.
- 7** Inspect the condition of the gasket. If the gasket is damaged, replace the gasket.
- 8** Reassemble by repeating the steps in reverse order.