



WARNING - Reliance on this Manual Could Result in Severe Bodily Injury or Death!

This manual is out-of-date and is provided only for its technical information, data and capacities. Portions of this manual detailing procedures or precautions in the operation, inspection, maintenance and repair of the product forming the subject matter of this manual may be inadequate, inaccurate, and/or incomplete and cannot be used, followed, or relied upon.

Contact Conair at info@conairgroup.com or 1-800-654-6661 for more current information, warnings, and materials about more recent product manuals containing warnings, information, precautions, and procedures that may be more adequate than those contained in this out-of-date manual.



USER GUIDE

UGD039-1006

SlimLine Compressed Air Dryer

Models 2.5, 5, 15, 25 and 50



INTRODUCTION • Purpose of the User Guide • How the guide is organized • Your responsibilities as a user • **ATTENTION:** Read this so no one gets hurt • **DESCRIPTION** • What is the SlimLine - Compressed air dryer ? • Typical applications • How it works: The SlimLine • How it works: Typical plant compressed air system • Specifications: SlimLine • **INSTALLATION** • Unpacking the boxes • Preparing for installation • Mounting the hopper/dryer onto a processing machine • Mounting a loader on the hopper • Mounting an optional hand-fill lid, models SL15, SL25, SL50 • Connecting the main power • Connecting a compressed air supply • Installing the optional slide gate • Installing the optional mounting adapter with drain • **OPERATION** • The SlimLine control panel • Loading material into the hopper • Adjusting the pressure regulator • To start drying • To stop drying • Setting the high alarm setpoint • Changing the temperature units (fahrenheit/celsius) • Using the optional slide gate • Using the optional mounting adapter with drain • **MAINTENANCE**

Please record your equipment's model and serial number(s) and the date you received it in the spaces provided.

It's a good idea to record the model and serial number(s) of your equipment and the date you received it in the User Guide. Our service department uses this information, along with the manual number, to provide help for the specific equipment you installed.

Please keep this User Guide and all manuals, engineering prints and parts lists together for documentation of your equipment.

Date:

Manual Number: UGD039-1006

Serial Number(s):

Model Number(s):

DISCLAIMER: The Conair Group, Inc., shall not be liable for errors contained in this User Guide or for incidental, consequential damages in connection with the furnishing, performance or use of this information. Conair makes no warranty of any kind with regard to this information, including, but not limited to the implied warranties of merchantability and fitness for a particular purpose.

Table of Contents

1-1 Introduction

Purpose of the user guide	1-2
How the guide is organized	1-2
Your responsibilities as a user	1-3
ATTENTION: Read this so no one gets hurt	1-4

2-1 Description

What is the SlimLine - Compressed Air Dryer?	2-2
Typical applications	2-2
How it works: The SlimLine	2-3
How it works: Typical Plant Compressed Air System	2-4
Specifications: SlimLine	2-5
Application data: SlimLine	2-5

3-1 Installation

Unpacking the boxes	3-2
Preparing for installation	3-3
Lifting the dryer (models SL25 and 50)	3-4
Mounting the hopper/dryer unit	3-5
Mounting a loader onto the hopper	3-6
Mounting a hand-fill lid (optional) on models SL15, SL25, SL50	3-7
Connecting the main power	3-7
Connecting a compressed air supply	3-8

4-1 Operation

The SlimLine control panel	4-2
Loading material into the hopper.	4-3
Adjusting the pressure regulator	4-3
To start drying.	4-4
To stop drying	4-5
Setting the high alarm setpoint	4-6
Changing the temperature units (fahrenheit/celsius)	4-6
Installing the optional slide gate	4-7
Installing the optional drain valve	4-8
Using the optional slide gate	4-9
Using the optional drain valve	4-10

5-1 Maintenance

Preventative maintenance checklist	5-2
Cleaning the hopper	5-3
Inspecting hoses	5-4

6-1 Troubleshooting

Before beginning	6-2
A few words of caution	6-3
<u>DIAGNOSTICS</u>	
How to identify the cause of a problem	6-4
Alarms	6-5
<u>REPAIR</u>	
Removing the cover on the dryer	6-8
Replacing fuses.	6-9

Check/Replace heater solid state relays	6-10
Checking the heater	6-11
Replacing the heater assembly	6-12
Replacing the differential pressure switch	6-13

A Appendix

We're here to help	A-1
How to contact customer service	A-1
Before you call...	A-1
Equipment guarantee	A-2
Performance warranty	A-2
Warranty limitations	A-2

B Appendix

Determining airflow in the SlimLine dryer	B-1
Relating the heater inlet pressure to the airflow	B-1
Calculating the airflow through the hopper to specify the mass of air	B-2

C Appendix

RTD temperature resistance chart	C-1
--	-----

D Appendix

Compressed air membrane option	D-1
Preparing to install the membrane	D-2
Using the wall mount bracket to mount the membrane assembly	D-2
Mounting the differential pressure gauge to the filterhead	D-3

D Appendix

Installing the compressed air piping for membrane assembly installation	D-3
Membrane installation	D-4
Start-up and operation	D-7
Maintenance and troubleshooting (general).	D-8
Maintenance and troubleshooting checkpoints	D-9
Filter elements	D-10
When to replace a filter element.	D-10
Filter element replacement	D-10
Automatic draining mechanism.	D-13
Drain provisions	D-14

Introduction

Purpose of the user guide. 1-2

How the guide is organized. 1-2

Your responsibilities as a user. 1-3

ATTENTION:

 Read this so no one gets hurt 1-4





Purpose of the User Guide

This User Guide describes the Conair SlimLine Compressed Air Dryer and explains step-by-step how to install, operate, maintain, and repair this equipment.

Before installing this product, please take a few moments to read the User Guide and review the diagrams and safety information in the instruction packet. You also should review manuals covering associated equipment in your system. This review won't take long, and it could save you valuable installation and operating time later.

How the Guide is Organized

Symbols have been used to help organize the User Guide and call your attention to important information regarding safe installation and operation.

-  Symbols within triangles warn of conditions that could be hazardous to users or could damage equipment. Read and take precautions before proceeding.
- 1** Numbers indicate tasks or steps to be performed by the user.
-  A diamond indicates the equipment's response to an action performed by the user.
- An open box marks items in a checklist.
- A circle marks items in a list.
-  Indicates a tip. A tip is used to provide you with a suggestion that will help you with the maintenance and the operation of this equipment.
-  Indicates a note. A note is used to provide additional information about the steps you are following throughout the manual.

Your Responsibility as a User

You must be familiar with all safety procedures concerning installation, operation and maintenance of this equipment. Responsible safety procedures include:

- Thorough review of this User Guide, paying particular attention to hazard warnings, appendices and related diagrams.
- Thorough review of the equipment itself, with careful attention to voltage sources, intended use and warning labels.
- Thorough review of instruction manuals for associated equipment.
- Step-by-step adherence to instructions outlined in this User Guide.

ATTENTION:

Read this so no one gets hurt

We design equipment with the user's safety in mind. You can avoid the potential hazards identified on this machine by following the procedures outlined below and elsewhere in the User Guide.



WARNING: Improper installation, operation, or servicing may result in equipment damage or personal injury.

This equipment should be installed, adjusted, and serviced by qualified technical personnel who are familiar with the construction, operation, and potential hazards of this type of machine.

All wiring, disconnects, and fuses should be installed by qualified electrical technicians in accordance with electrical codes in your region. Always maintain a safe ground. Do not operate the equipment at power levels other than what is specified on the machine serial tag and data plate.



WARNING: Voltage hazard

This equipment is powered by single-phase alternating current, as specified on the machine serial tag and data plate.

A properly sized conductive ground wire from the incoming power supply must be connected to the chassis ground terminal inside the electrical enclosure. Improper grounding can result in severe personal injury and erratic machine operation. (120 Volt units come with a grounded plug. Must be plugged into a grounded out.)

Always disconnect and lock out the incoming main power source before opening the electrical enclosure or performing non-standard operating procedures, such as routine maintenance. Only qualified personnel should perform troubleshooting procedures that require access to the electrical enclosure while power is on.



CAUTION: Hot Surfaces

Always protect yourself from certain exterior surfaces that can reach temperatures in excess of 200°F (93°C). These surfaces include the hopper cone and the exterior of the dryer casting. Also exercise caution around hot surfaces inside the dryer when cleaning or accessing the inside of the hopper.

Description

What is the SlimLine -
 Compressed air dryer? 2-2
Typical applications. 2-2
How it works: SlimLine. 2-3
How it works: Typical plant compressed air
 system 2-4
Specifications: SlimLine 2-5

What is the Compressed Air Dryer?

The SlimLine is an integral dryer and hopper used to dry hygroscopic resin pellets. The dryer uses compressed air in an open loop configuration and heats the air with an electric resistance heater to dry pellets located in the hopper.

The dryer must be supplied with clean, dry compressed air supplied at 40° F {4° C} dewpoint and 100 psi with a oil content of less than 3 mg/m³ to produce hot, low dewpoint air that removes moisture from hygroscopic plastic.

Typical Applications

- 1 Dryer/hopper mounted on the machine throat.

Model	Drying Temperature Range
Standard	100° - 350°F {38° - 177°C}

- Throughput rates of 0.25 to 50 lbs {0.12 to 23 kg} per hour (some materials can be run at a higher rate).
- Dewpoints of 0°F {-18°C} (standard dryer)
- Dewpoints of -40°F {-40°C} (dryer equipped with an optional membrane)
See Appendix D for instructions for installing, operating and troubleshooting the optional membrane assembly.

How It Works: The SlimLine

The SlimLine Compressed Air Dryer achieves continuous, single pass drying by expanding compressed air and then passing the air through a heater(s) and injecting it into the hopper.

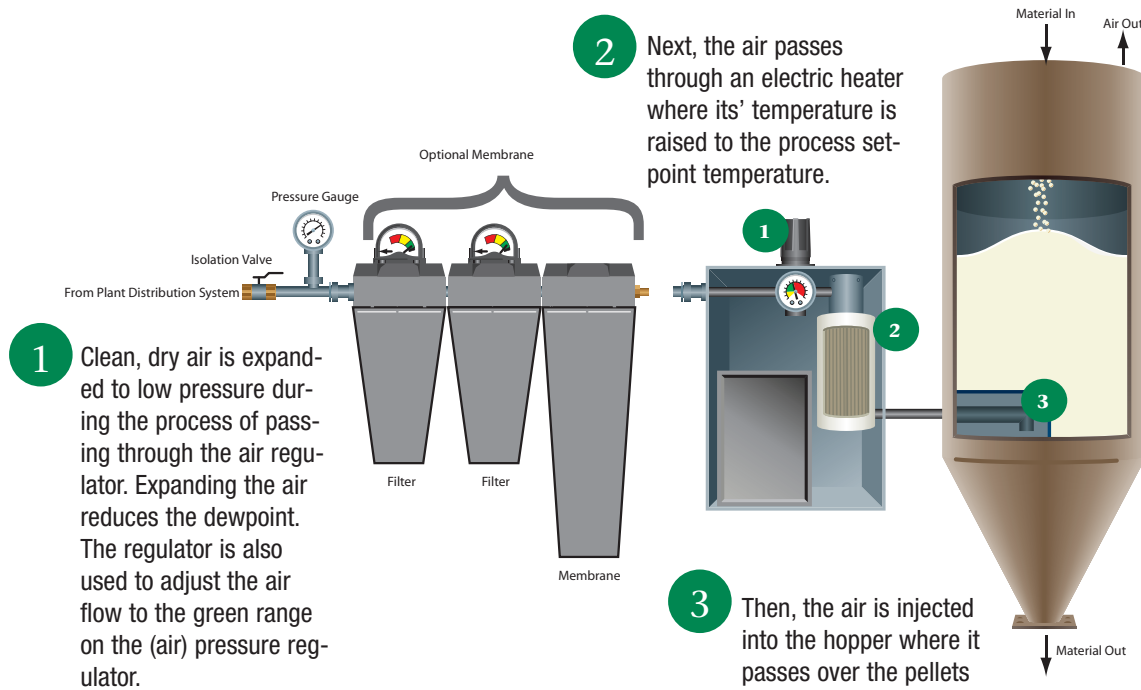

 **Note:** The membrane is sold as an option to the SlimLine standard dryer. See [Appendix D](#) for instructions for installing, operating and troubleshooting the optional membrane assembly.

The air exhausts from the hopper into the atmosphere.

* This drawing is used to facilitate the understanding of how the dryer works and is not an actual representation of your dryer. For example, the compressed air is plumbed on the opposite side on the dryer you purchased.

How It Works: Typical Plant Compressed Air System

Pre-dried compressed air at a specification of 40° F {4° C} dewpoint and 100 psi with a maximum oil content of 3 mg/m³ is obtained with a properly sized typical plant compressed air system as shown below.

1 The typical plant-sized compressor draws in ambient air and compresses it to 100 - 150 psi {6.9 - 10.3 bar}. A compressor compresses air by applying mechanical force. Heat is generated as a byproduct of the compression cycle.

As air passes through the receiver it cools, reducing the dewpoint and the temperature of the air.

Some water will collect and drain from the receiver.

Filters: Filters are recommended for protecting the devices downstream from their location from moisture, oil and/or dirt.

There should also be **low point traps** with automatic drains to allow trapped condensation to leave the system.

2 Next, the air passes through an aftercooler that helps to lower the temperature of air, this reduces both the moisture in the air and condensation in the the compressed air lines.

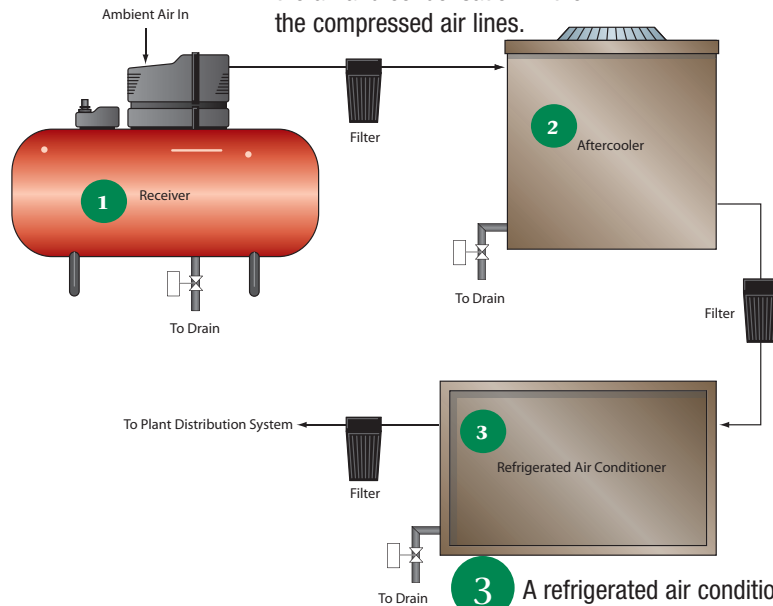

3 A refrigerated air conditioner (RAC) is installed in the compressed air system before the air enters the plant's distribution system. This system evaporates refrigerant at ~ 34° F {1° C} and serves to cool the compressed air to about 40° F {4° C}, hence the dewpoint to 40° F {4° C}. The air leaving the RAC is significantly warmer than 40° F {4° C} because the leaving air is passed through an economizer to reduce the energy consumption and prevent condensation on the air pipes leaving the refrigerated air conditioner.

Specifications: SlimLine Compressed Air Dryers

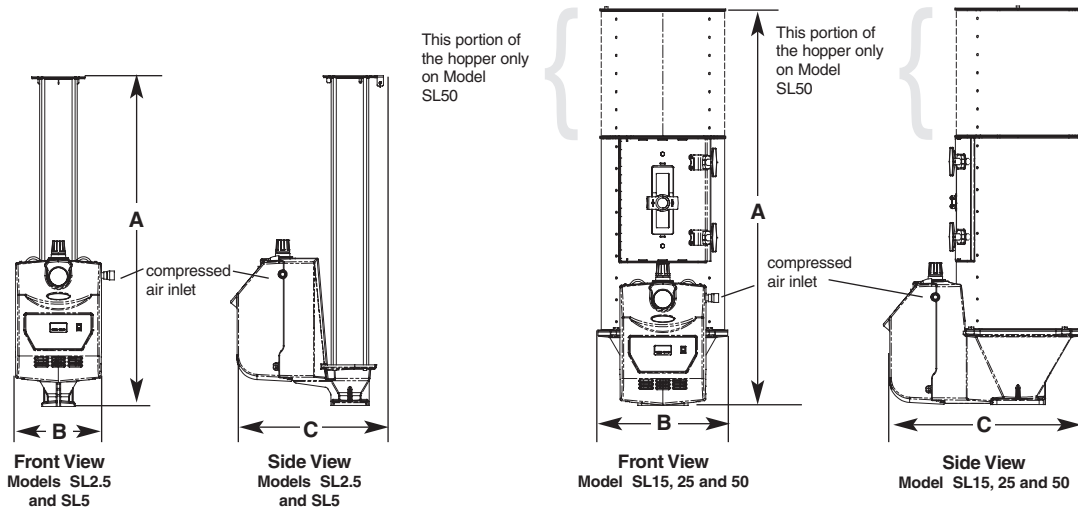

Description **2**

MODEL	SL2.5	SL5	SL15	SL25	SL50	SPECIFICATION NOTES:
Performance characteristics (with full hopper)						
Drying temperature	All models 100 - 350°F {38 - 176°C}					SCFM - Standard Cubic Feet per Minute SLM - Standard Liters per Minute *Compressed air supplied to the dryer must meet specification requirement of 100 psi and 40°F {4°C} dewpoint and a residual oil content of less than 3mg/m ³ .
Dewpoint	0°F {-18°C} with optional membrane - 40°F {-40°C}					
Airflow SCFM {SLM}	2.5 {70.8}	5 {141.6}	7.5 {212.4}	12.5 {354.0}	25.0 {708.0}	
Airflow with membrane SCFM {SLM}	3.1 {88.0}	6.8 {193.0}	9.3 {263.0}	15.7 {445.0}	34.9 {988.3}	
Hopper volume ft ³ {L}	0.125 {3.5}	0.25 {7.1}	0.75 {21.2}	1.25 {35.4}	2.5 {71.0}	
Heater size kW	1	1	1	2	2	
Dimensions inches {cm}						
A - Height	22.5 {57.2}	40.0 {101.6}	26.5 {67.3}	32.0 {81.3}	47.5 {120.7}	Specifications may change without notice. Consult a Conair representative for the most current information.
B - Overall width	11.0 {27.9}	11.0 {27.9}	12.5 {31.8}	15.5 {39.4}	15.5 {39.4}	
C - Depth	19.0 {48.3}	19.0 {48.3}	25.5 {64.8}	24.0 {61.0}	24.0 {61.0}	
Drying hopper inlet pipe size	1/2 NPT female					
Weight lbs {kg}						
Standard dryer installed (empty)	32 {14.5}	37 {17}	56 {25}	87 {39}	107 {49}	
Shipping	60 {27.2}	70 {31.8}	160 {72.6}	160 {72.6}	160 {72.6}	
Voltage - Total amps						
120 V/1phase/60 Hz	8.5	8.5	8.5	16.7	16.7	
220 V/1 phase/50 Hz	4.3	4.3	4.3	8.4	8.4	
Compressed air requirements						
100 PSI, clean dry compressed air pressure dewpoint of 40°F {5°C} ; residual oil content of less than 3 mg/m ³						
APPLICATION NOTES:						
Conair recommends purchasing the optional membrane when:						
<ul style="list-style-type: none"> your process requires that you obtain a dewpoint of -40°F {-40°C}; or the compressed air dewpoint you are supplying is above 40°F {4°C}. 						

TPDS026/0506

Application data: SlimLine Compressed Air Dryers

1 Identify the resin and throughput rate. Use the chart as a reference for determining your throughput rate.

MATERIAL	DRYING TEMP/F {°C}†	DRYING TIME/HOUR*	BULK DENSITY‡	MODEL THROUGHPUT RATE** / LB/HR				
				SL2.5	SL5	SL15	SL25	SL50
ABS (0.05%)§	180-190 {82-88}	2	40	2.5	5	15	25	50
Acetal	180-230 {82-110}	2	40	2.5	5	15	25	50
Acrylic	170-180 {77-82}	2	40	2.5	5	15	25	50
Nylon (0.6%)§	160-180 {71-82}	6	40	0.4	0.8	5	8.3	16.6
PBT	210-260 {99-127}	4	45	1.3	2.5	7.5	12.5	25
PC	250 {121}	2	40	2.5	5	15	25	50
PET (0.05%)§	300-350 {144-177}	2	50	2.5	5	15	25	50
PETG (0.04%)§	150 {66}	6	40	0.4	0.8	5	8.3	16.6
Polysulfone	200-275 {93-135}	4	35	1.3	2.5	7.5	12.5	25
Polyurethane	180-210 {82-99}	3	40	NA††	NA††	NA††	16.6	33
PPO	190-230 {88-110}	4	50	1.3	2.5	7.5	12.5	16.6
PPS (0.04%)§	270-300 {132-144}	6	50	0.4	0.8	5	12.5	16.6
SAN	160-180 {71-82}	3	45	1.6	3.3	10	16.6	33

APPLICATION NOTES:

* This dryer is not recommended for applications using a high percentage of regrind ($\geq 20\%$).

† The parameters of drying temperature and time may vary depending upon the type, grade and manufacturer of the material being processed. Consult your material supplier for their precise recommendations.

‡ Unit of measurement for bulk density is lb/ft³. Bulk density listed is the nominal weight for typical pellets. The bulk density may vary somewhat depending upon the size and shape of the pellets. The bulk density of regrind may vary widely depending upon the size and the shape of the flake. Be sure to consider the bulk density of the material when selecting the capacity of the drying hopper and the drying time desired.

§ Number refers to the residual moisture content by weight of the pellet at the listed throughputs and drying times. To increase the level of dryness, the throughput of the material would need to be decreased and the drying time increased.

** Throughputs will vary by type of material. Consult Conair about throughput for materials that are not listed here.

†† Dryer is not recommended for this application due to bridging of material in the smaller hopper opening.

Installation

Unpacking the boxes	3-2
Preparing for installation	3-3
Lifting the dryer (models SL 25 and 50)	3-4
Mounting the hopper/dryer unit	3-5
Mounting a loader onto the hopper.	3-6
Mounting a hand-fill lid (optional) on models SL15, SL25 and SL50	3-7
Connecting the main power.	3-7
Connecting a compressed air supply.	3-8

Unpacking the Boxes

The SlimLine dryer comes in one to several boxes, depending on the model and options ordered. The boxes could include (depends on the options selected):



- Compressed air dryer/hopper



- Hand-fill lid (standard on SL2.5 and SL5; optional on SL15, SL25 and SL30)

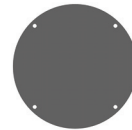

Model SL15
Hopper has a hinged top plate. Hand-fill lid needed to cover center hole.

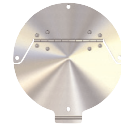

Model SL25 and SL50

- IB06 mounting interface (pre-mounted and standard on SL15, SL25 and SL30)

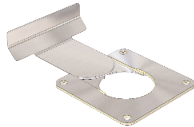

- Slide gate (option)

- Mounting adapter with drain (option)



- Compressed air membrane (option) *See Appendix D for instructions for installing, operating and troubleshooting the optional membrane assembly.*

- User manual and wiring diagrams (not shown)

1 Carefully remove the dryer and components from their shipping containers, and set upright. Note that the dryer (depending on model ordered) may be secured to its shipping container with 4 bolts that pass through the bottom of the mounting flange.

2 Remove all packing material, protective paper, tape, and plastic.

3 Carefully inspect all components to make sure no damage occurred during shipping, and that you have all the necessary hardware. If damage occurred during shipping notify the shipping agent immediately.

Preparing for Installation

The SlimLine dryer is easy to install if you plan the location and prepare the mounting area properly.

1 Make sure the mounting area provides:

❑ **A grounded power source supplying the voltage and correct current** for your dryer model. Check the dryer's serial tag (models 2.5 and 5, located on the right side of the cover; models 15, 25 and 50 on the back of the hopper) for the correct amps, voltage, phase, and cycles. Any field wiring should be completed by qualified personnel to the planned location for the dryer. All electrical wiring should comply with your region's electrical codes.

❑ **Clearance for safe operation and maintenance.**

❑ **A compressed air supply.** It is necessary to supply compressed air to the dryer. Your plant system must be capable of supplying 100 psi {6.9 bar} and 40°F {4°C} dewpoint with a residual oil content of less than 3 mg/m³.

IMPORTANT: The flow rate of the compressed air must be at 100 psi {6.9 bar} at the entrance to the dryer (or the optional membrane). If your plant compressed air system, does not meet this specification you will not achieve desired drying results.



Note: If your compressed air system is not capable of supplying the Conair recommended dewpoint listed above you will need to purchase the optional membrane to ensure proper drying.

❑ **Flex hose for connecting compressed air to the dryer.** It is also acceptable to use a rigid, 1/2 inch NPT union and compressed air supply pipe to make the connection from the compressed air source to the dryer.

See **Installation section entitled, *Connecting a compressed air supply.***

❑ **Conair recommends the installation of an isolation valve installed on the compressed air line leading to the dryer or membrane (if installed).** You will use the valve to shut off compressed air to your dryer for cleanout, material changes or maintenance.

❑ **Conair recommends the installation of a pressure gauge (0 - 160 psi) {0 - 11 bar} downstream of the isolation valve to check the supply of air pressure being supplied to the dryer.** You will need to install the pressure gauge before the membrane (if installed) or the dryer to obtain accurate pressure readings.

See **Appendix D** for *instructions for installing, operating and troubleshooting the optional membrane assembly.*

Lifting the Dryers (Models SL25 and SL50)

For increased safety in lifting Conair recommends that all dryer/hopper units are lifted without material in the hopper. When using the lifting lugs on models SL25 and SL50 it is required that no material be in the hopper.



CAUTION: Always make sure that the top section of the SL50 is securely attached before lifting the unit. Always make sure the loader adapter plate is secure on the SL25 and SL50 before lifting the units. Failure to do so could result in injury to personnel.

- 1 Bolt the upper section of the hopper (model SL50 securely into place.)** This prevents the twist lock feature from unlocking and separating. See illustrations below.
- 2 Bolt the loader adapter plate (models SL25 and SL50) securely in place.** This secures the lid to the hopper and prevents it from sliding off during installation. See illustration below.
- 3 Use the lifting lugs (models SL25 and 50) to lift the empty dryer onto the mounting location.**
- 4 Remove the lifting lugs (SL25 and 50) after mounting the dryer.**
- 5 Reverse the procedure to remove the dryer from the machine.**

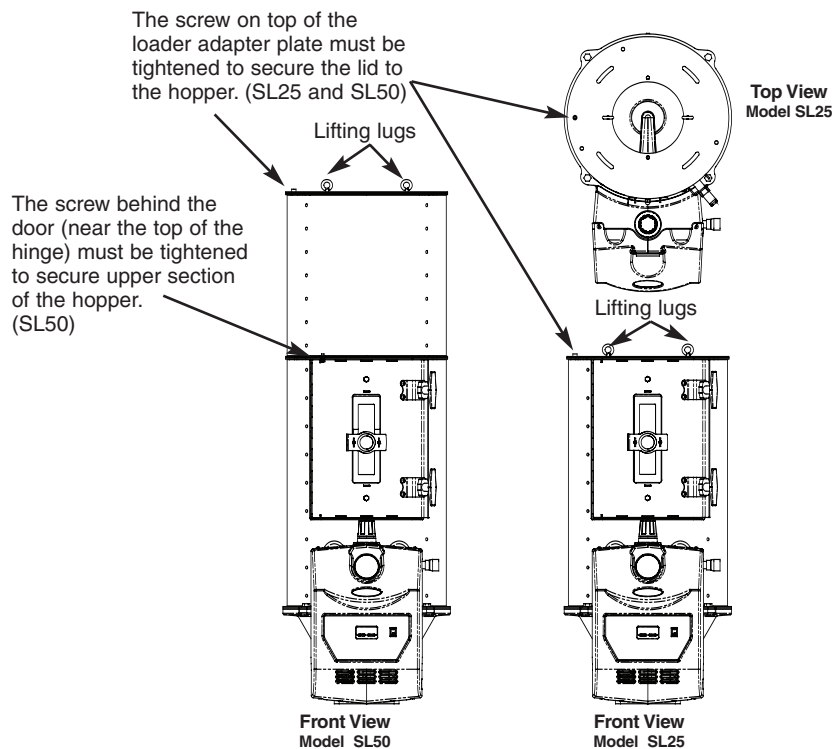

Mounting the Hopper/Dryer Unit

The hopper bolts to the throat of the processing machine.

- 1 Lift the unit onto the throat of the processing machine.** Position the hopper discharge assembly so that its bolt holes line up with the holes drilled in the throat. If hole patterns do not match, you can place a mounting adapter between the throat and the support frame.
- 2 Bolt the unit to the throat of the processing machine.** Using four 3/8"-16 (M 10) self-locking bolts, fasten the hopper/dryer to the throat. The bolts must be long enough to reach at least 1/2 inch (1.25 cm) into the processing machine throat or mounting adapter after passing through the hopper discharge assembly.

 **NOTE:** If your mounting surface does not match the standard bolt patterns available, you will need an adapter. You can make an adapter using the dimensions provided or purchase one from Conair. Contact Conair Parts at 1.800.458.1960. From outside the United States, call 814.437.6861

Base Plate IB01

standard on models SL2.5, SL5 and SL15

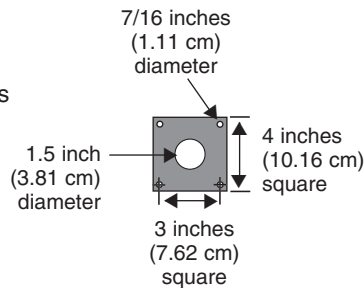

Base Plate IB02

standard on models SL25 and SL50

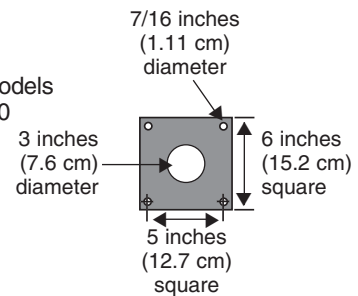

Mounting a Loader on a Hopper

Models SL2.5 and SL5 (option)

◆ **Tip:** To prevent material contamination Conair recommends that the hopper be covered with a loader or a hand-fill lid.

If your SL2.5 or SL5 was purchased with the loader fill option, you will need to mount the TLA loader to the adapter on top of the glass hopper.

- 1 Position the loader body onto the top of the TLA adapter.** Position the loader assembly so that it fits snugly on to the top of the TLA mounting adapter located on top of the glass hopper. Tighten the thumbscrews.
- 2 Supply power to the TLA loader.** Refer to the manual the came with your loader for specific instructions.
- 3 Supply compressed air to the TLA loader.** Refer to the manual the came with your loader for specific instructions.

 **NOTE:** The SL2.5 and SL5 units are equipped with a hand-fill lid as standard. There is an optional mounting loader adapter and loader available for this unit. To purchase from Conair. Contact Conair Sales at 1.800.654.6661, from outside the United States, call 412.312.6000



Mounting a Loader on a Hopper

Models SL15, SL25 and SL50

If you have a Conair loader or vacuum receiver, you can use the flange provided on the top of the hopper to mount the loader. Refer to the manual that came with your receiver or loader for detailed installation instructions.

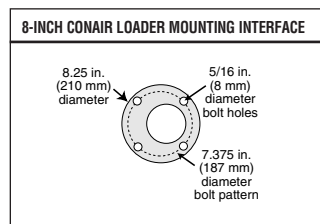

Mounting the Hand-fill Lid Models SL15, SL25 and SL50

Models SL15, SL25 and SL50 come standard with an IB06 mounting interface for loader fill. If you choose not to use a loader on one of these units, purchase and install the optional hand-fill lid to prevent material contamination or moisture regain.

• **Tip:** To prevent material contamination Conair recommends that the hopper be covered with a loader or a hand-fill lid.

1 Bolt the hand-fill lid to the top of the hopper.

Use the bolts provided to secure the hand-fill lid to the top of hopper.

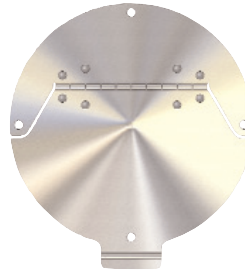

Represents the hand-fill lid for Models SL25 and SL50.

Connecting the Main Power

The dryer operates from standard 120 Volt, 60 Hz or 220 Volt, 50 Hz depending on the option selected when purchased.

1 Plug the dryer into a properly sized electrical outlet.

Model - 120 Volt

SL2.5, SL5 and SL15	15A, 120 V
SL25 and SL50	20A, 120 V

Model - 220 Volt

All	15A, 220 V
-----	------------

 **NOTE:** Dryers ordered with 220 Volt will need to be wired to a disconnect that is protected by properly sized protectors (fuses or breaker).

 **CAUTION:** Always disconnect and lock out the main power sources before making electrical connections. Electrical connections should be made only by qualified personnel.



IMPORTANT: Always refer to the wiring diagrams that came with your dryer to locate specific electrical components. Illustrations in the User Guide are intended to be representative only.

Connecting a Compressed Air Supply

It is necessary to supply a compressed air supply to the dryer. Your plant system must be capable of supplying 100 psi {6.9 bar} and 40°F {4°C} dewpoint with a residual oil content of less than 3mg/m³ specification.

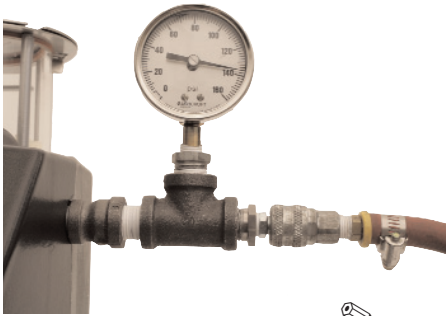

- 1 Connect compressed air to the 1/2 inch NPT female inlet of the dryer.** You can use a piece of flex hose to make the connection. The hose should be pressure and temperature rated for this the application. The tubing should be cut to length for efficiency. It is also acceptable to use a rigid, 1/2 inch NPT union and compressed air supply pipe to make the connection from the compressed air source to the dryer.



Note: All connections should have an isolation valve and pressure gauge (customer supplied) for verification of pressure. The flow rate of the compressed air must be at 100 psi {6.9 bar} at the entrance to the dryer (or the optional membrane). If your plant compressed air system, does not meet this specification you will not achieve proper drying. Since pressure drops occur during flow you must verify that the 100 psi {6.9 bar} specification is met when air is flowing.

IMPORTANT: The compressed air source must deliver 100 psi {6.9 bar} of clean, dry (non-lubricated), air pressure at the design flow. The air connected to the dryer cannot be lubricated, if it is your material will become contaminated with the lubrication.

IMPORTANT: You should not use threaded sealant tape on the compressed air connection. Use of these items can contaminate your compressed air circuit. A quick disconnect fitting may be used to facilitate easy air line connection and removal for the main supply line, but the fitting should not be the type that restricts air flow.

- 2 Confirm a good connection with a gentle tug.**



CAUTION: Always provide hazard-free routing of compressed air tubing, to keep it away from hot or moving surfaces and out of the way of personnel.

Operation

The SlimLine: control panel	4-2
Loading material into the hopper	4-3
Adjusting the pressure regulator	4-3
To start drying	4-4
To stop drying	4-5
Setting the high alarm setpoint	4-6
Changing the temperature units (fahrenheit/celsius)	4-6
Installing the optional slide gate	4-7
Installing the optional drain valve	4-8
Using the optional slide gate	4-9
Using the optional drain valve	4-10

The SL Series Compressed Air Dryer Control

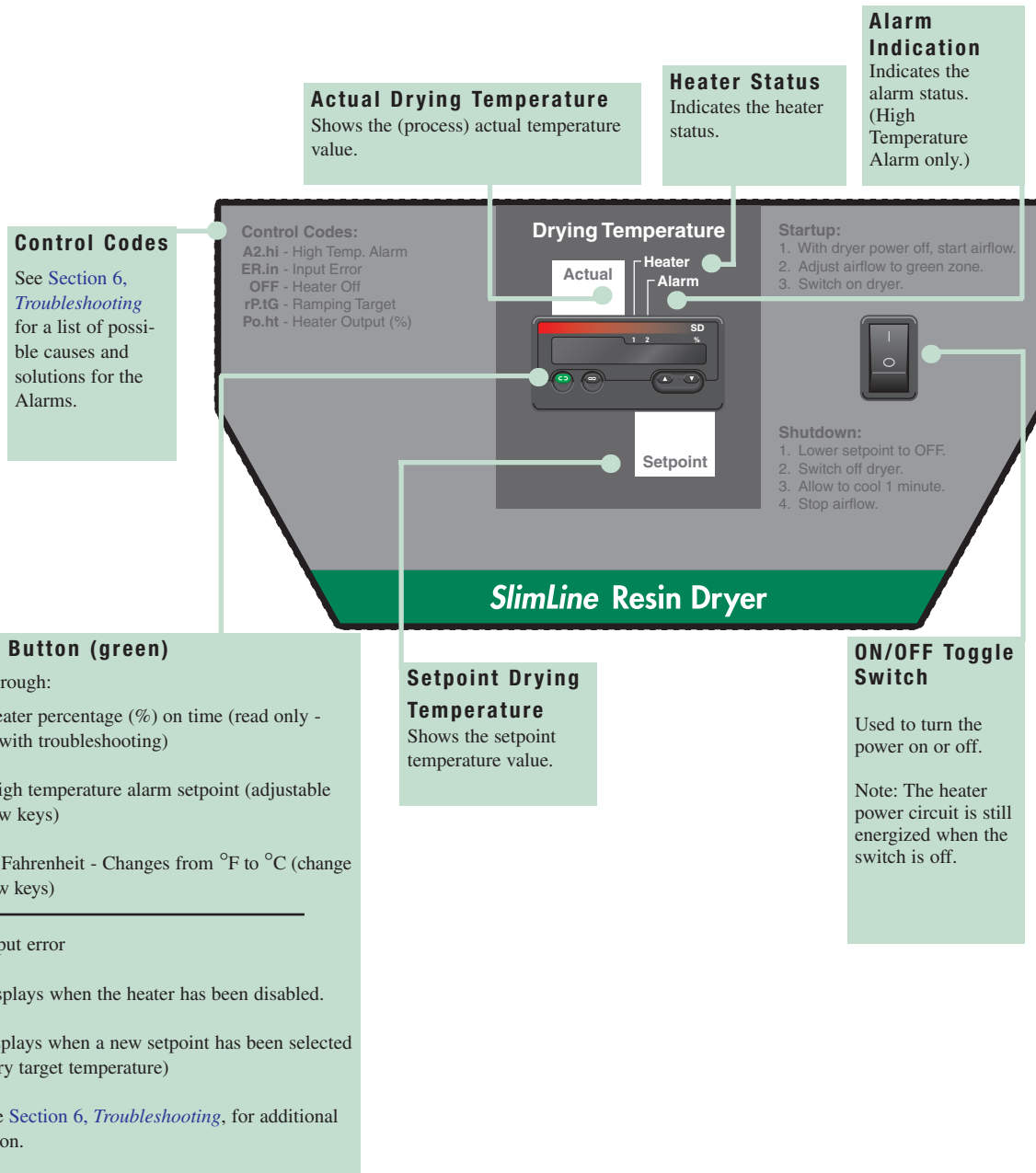

Loading Material into the Hopper

1 Use your installed conveying equipment or hand-fill material into the hopper.

◆ Tip: If you hand-fill your hopper remember to close the lid to reduce moisture regain and to keep you material contaminant-free.

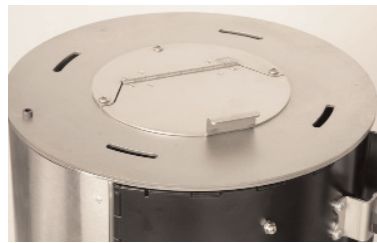

Adjusting the Pressure Regulator

1 Turn the knob of the pressure regulator in a clockwise direction to allow increased airflow.

 **Note:** If the regulator does not move easily, pull up on the knob to unlock it.



2 Adjust the air flow so that the pressure gauge reads at the top of the green level.

3 Push down on the knob to lock the pressure gauge at a flow rate in the green area on the gauge.



 **CAUTION:** **DO NOT** set the pressure in the red section of the pressure gauge. Damage to the internal components of the dryer can occur at high pressure.

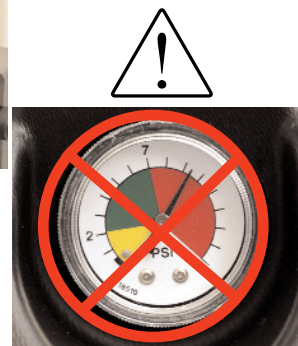

DO NOT set the pressure in the red section of the pressure gauge.

Starting the Dryer

You have completed the installation. Now it's time to make sure everything works.



On Position

1 Adjust airflow appropriately. See [Operation section entitled, *Adjusting the pressure regulator.*](#)

2 Toggle the power switch to the on position. The control display will illuminate. Facing the dryer, the (process) actual temperature will be on the left, the setpoint is on the right.

3 Set the drying temperature setpoint. Use the up arrow button ▲ on the control, to raise the setpoint. Use the down arrow button ▼ to lower the setpoint. The temperature will ramp up at 1 (one) degree per second. After 2 (two) seconds of inactivity the setpoint you entered will become the targeted setpoint.

 **NOTE:** If the setpoint displays “OFF” in the window raise the setpoint with the up arrow button ▲ to see the actual setpoint.



4 The setpoint and actual temperature will show in the display. Facing the dryer, the (process) actual temperature will be on the left, the setpoint is on the right.

5 Pre-dry for approximately three hours* before you begin to process material. *Three hours is an estimated pre-drying time, some material may require a longer or shorter pre-drying time. See [Description section entitled, *Application Data.*](#)

 **Tip:** Conair recommends that you keep the material level within three inches from the top of the hopper to allow enough residence time for the material to be properly dry.

6 Open the slide gate (optional) and begin processing.

Stopping the Dryer

- 1 Close the (optional) slide gate.
- 2 Press the down arrow ▼ to lower the setpoint until the control says **OFF** on the display. This disables the heater.
- 3 Toggle the switch to the off position.



Off Position

- 4 Allow five minutes for the heaters to cool down.
- 5 Turn the pressure regulator counter-clockwise until the compressed air flow stops.



☛ **Tip:** To keep material dry without processing let a little air move through the dryer at an idle setpoint.

📌 **NOTE:** Moisture regain will be reduced if a small amount of compressed air is allowed to pass through the material even with the power off.

Setting the High Alarm Setpoint

 **NOTE:** Processing is not affected by this adjustment.

1 Press the green return button twice. 

A2.hi will appear on the right side of the controller as you are facing the dryer. The setpoint appears on the left.

2 Press the ▲ or ▼ buttons to select the high alarm setpoint. The setpoint you choose will depend on the specific properties of your material. Your material supplier provides recommendations for proper drying.



◆ **Tip:** See also, [Section 6, Troubleshooting](#) for information on how to reset this setpoint if an A2.hi alarm occurs.

3 The infinity button  will take you back to the main screen, where you will see the setpoint and actual temperature displayed. The control will default back to the main screen after 1 minute.



CAUTION: The high alarm setpoint should be lowered if the material being processed would be damaged or melt at the factory default setting of 450°F {232°C}.



CAUTION: **DO NOT** set the dryer above the default of 450°F {232°C}. The dryer is not rated for temperatures above 450°F {232°C}. Setting it above that temperature could cause damage to the dryer or your material.

 **NOTE:** Processing is not affected by this adjustment.

Changing Temperature Units from Fahrenheit to Celsius



1 Press the green return  button three (3) times. Press the ▲ or ▼ buttons to toggle between the temperature units of fahrenheit and celsius.

2 Press the infinity button  to lock in your selection and return to the main screen where you will see the setpoint and actual temperature displayed. The control will default back to the main screen after 1 minute.

Installing the optional Slide Gate Valve

 **NOTE:** If you are following this set of instructions and your SL dryer/hopper is not installed, you may skip to step 3.

- 1 Disconnect and lockout the main power.** If you have mounted a loader or vacuum receiver on the hopper, disconnect the material inlet hose at the source.
- 2 Disconnect the compressed air supplied to the dryer.**

3 Remove the slide gate assembly from the boxes.

4 Prepare to mount the slide gate. Decide which orientation best fits your application. The slide gate can be mounted in any of the four basic directions on the throat of the machine. You will want to select the orientation that has the best clearance for opening and closing the slide gate.

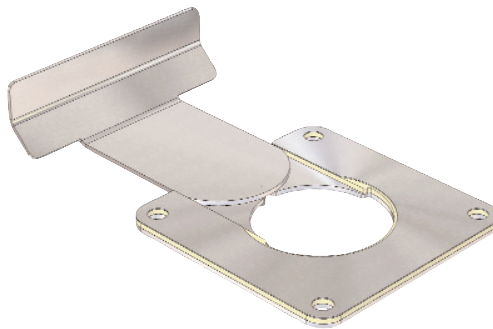

- 5 Fasten the lower plate (thicker), the nylon spacer and the thin upper plate in the orientation you selected for your application.**
- 6 Securely tighten all four fasteners using a thread locking compound and/or self-locking fasteners.**
- 7 To operate the slide gate** See [Operation section entitled, Using the optional slide gate.](#)

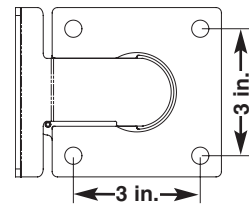

Models SL2.5,
5 and 15

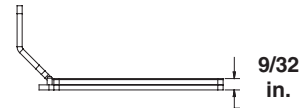

Models SL 2.5,
5 and 15

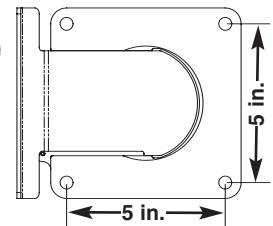

Models SL25
and 50



Models SL25
and 50

4
Operation

Installing the optional Drain Valve

 **NOTE:** If you are following this set of instructions and your SL dryer/hopper is not installed, you may skip to step 3.

- 1 Disconnect and lockout the main power.** If you have mounted a loader or vacuum receiver on the hopper, disconnect the material inlet hose at the source.
- 2 Disconnect the compressed air supplied to the dryer.**

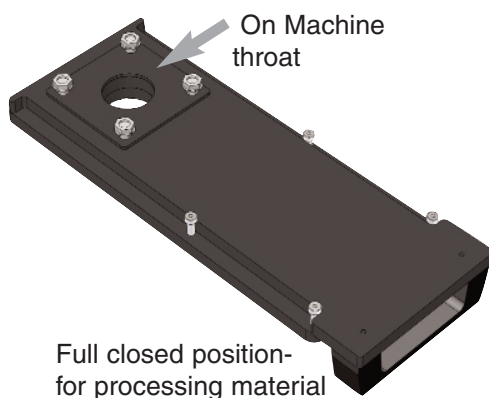
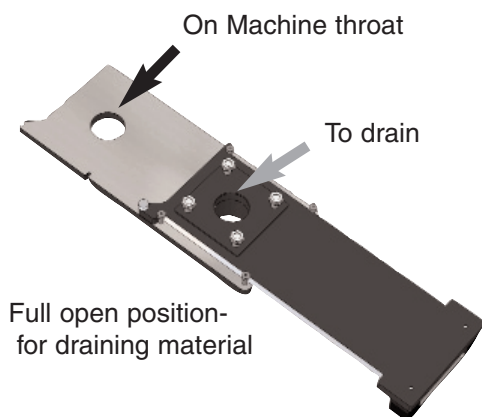

- 3 Remove the drain valve assembly from the boxes.**
- 4 Prepare to mount the slide gate.** Decide which orientation best fits your application. The slide gate can be mounted in any of the four basic directions on the throat of the machine. You will want to select the orientation that has the best clearance for opening and closing the draining valve.
- 5 Remove the stainless steel cladding on the lower slide plate.**
- 6 Drill the required pattern to fasten the drain valve to the mounting location.**
- 7 Countersink the heads of the fasteners flush with the upper surface of the lower carbon steel plate.**
- 8 Tighten the fasteners with thread lock to prevent loosening from vibration.**
- 9 Reassemble the valve with 24 gauge stainless steel cladding on the lower plate and tighten the shoulder bolts, (supplied) use a thread locking compound to secure bolts.**
- 10 To operate the drain valve** See [Operation section entitled, Using the optional drain valve.](#)



WARNING: MOVING PARTS; PINCH POINTS Use care around the drain gate valve to avoid a possible pinching injury.

Using the Slide Gate Valve

- 1** Turn off and disconnect the main power supply to the dryer.
- 2** Pull the handle toward the front of the dryer to open the slide gate.
- 3** Push the handle toward the rear of the dryer to close the slide gate.

 **NOTE:** In an intermediate position the material will be shut off from the throat of the machine and not drained.

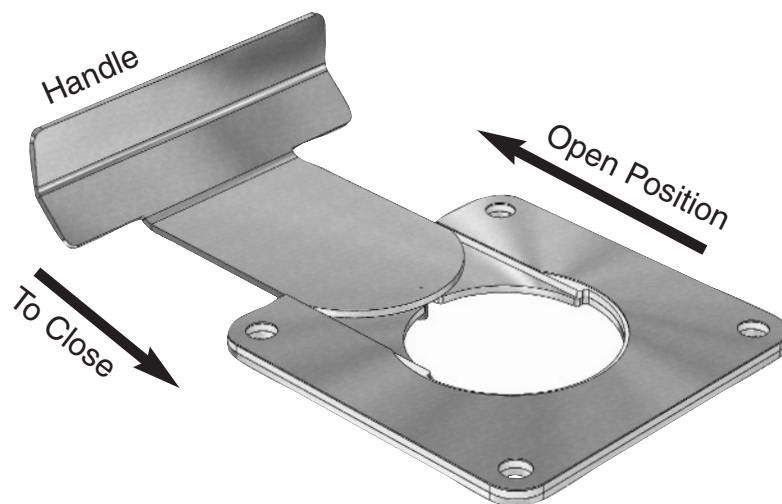

 **WARNING: MOVING PARTS; PINCH POINTS** Use care around the slide gate valve to avoid a possible pinching injury.

Using the Optional Drain Valve

The drain valve can be in the processing (open to the processing machine throat), the standby (closed) or the drain position (over the drain tube).

- 1 Turn off and disconnect the main power supply to the dryer.**
- 2 Shut the slide valve (optional).** This isolates the hopper from the throat of the machine.
- 3 Pull the dryer/hopper unit toward the dump chute.** To move the drain valve assembly lift the locking pin and pull the handle to the desired location. Listen to the locking pin and visually verify that the unit has snapped into place.
- 4 Connect the black pipe discharge to a piece of 1 1/2 inch flex hose. Direct the hose into a bucket or some type of receptacle.**
- 5 Open the slide valve (if equipped) and drain the material.**
- 6 Close the slide valve (if equipped).**
- 7 Slide the dryer/hopper unit back into position.** Listen to the locking pin and visually verify that the unit has snapped into place. Make sure that personnel and tools are clear of the processing machine throat, lift the pin and slide the drain valve over the throat.



WARNING: MOVING PARTS Use care around the throat of the processing machine. When the dryer is pulled off of the throat of the processing machine it will expose dangerous moving components. Keep all body parts and clothing away from the machine throat to avoid serious injury.



NOTE: In an intermediate position the material will be shut off from the throat of the machine and not drained.

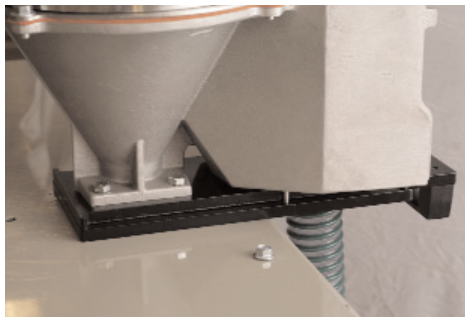

Processing position

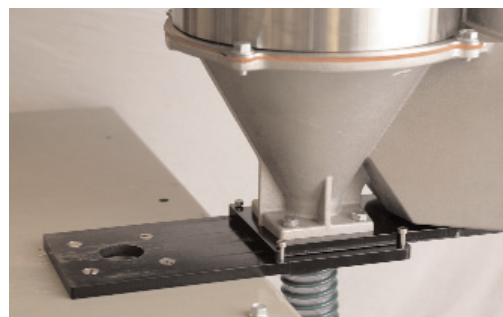

Draining position

Maintenance

Preventative maintenance checklist 5-2
Cleaning the hopper. 5-3
Inspecting hoses 5-4

Preventative Maintenance Checklist

Routine maintenance will ensure optimum operation and performance of the SlimLine Dryer. We recommend the following maintenance schedule and tasks.

- **Whenever you change materials**

- Drain and clean the hopper.**

- **Weekly, or as often as needed**

- Check the quality of your compressed air.**

You may need to clean filters more often than weekly. Frequency depends on how much material you process and how dusty or full of fines it is. You should replace any filter if it damaged, excessively worn or too clogged to be properly cleaned.

- **Every six months**

- Inspect hoses for damage or wear.**

Damaged compressed air hose can allow moisture or contamination to seep into the drying system. Replace any hose that is torn or cracked.

- Inspect the installation**

Check installed mounting hardware to make sure that the installation is secure.

- Inspect the compressed air system**

Check the compressed air system for leaks. Compressed air leaks could compromise the performance of the SlimLine dryer.

Cleaning the Hopper



CAUTION: Hot surfaces. Always protect yourself from hot surfaces inside and outside the dryer and drying hopper.

The hopper assembly should be cleaned thoroughly between material changes to prevent resin contamination.

- 1 Close the hopper slide gate if the option was purchased on your dryer.**
- 2 Remove the material from the dryer.**
- 3 Wipe the material surfaces.** Use a clean, oil-free rag to wipe the internal surfaces of the hopper.



Inspecting Hoses

Loose or damaged hoses can allow moisture regain or material contamination. Compressed air leaks are also expensive and wasteful.

- 1 Inspect all hoses, clamps, fittings.**
- 2 Tighten any loose hose clamps or fittings.**
- 3 Replace worn or damaged hoses.**

Troubleshooting

Before beginning 6-2

A few words of caution 6-3

DIAGNOSTICS

How to identify the cause of a problem 6-4

Alarms 6-5

REPAIR

Removing the cover on the dryer 6-8

Replacing fuses 6-9

Check/Replace heater solid state relays . . . 6-10

Checking the heater 6-11

Replacing the heater assembly 6-12

Replacing the differential pressure switch . . 6-13

Before Beginning

You can avoid most problems by following the recommended installation and maintenance procedures outlined in this User Guide. If you do have a problem, this section will help you determine what caused it and how to fix it.

❑ Diagnose causes from the control panel.

- 1** Press  once to acknowledge the alarm and resume control if required.
- 2** Address the alarm message and fix the problem.
- 3** If the alarm reappears the problem was not fixed.

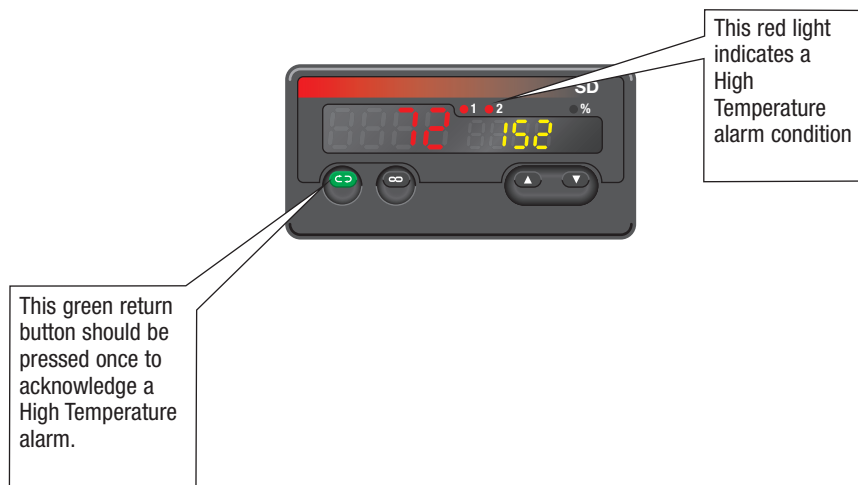

- ### ❑ If you need to call Conair Service for assistance please note the percent (%) on time of the heater. It will be important in troubleshooting a dryer malfunction. Also take note of the setpoint and actual temperatures, the line pressure and regulator setting.

 **NOTE:** The percent (%) on number can be read from the first menu displayed on the controller, by pressing the green return button one (1) time. This number should only be read after the unit has had time to stabilize at the setpoint temperature.

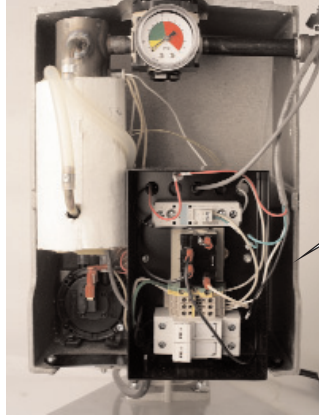

See warnings below.

(continued)

Open the electrical enclosure to check fuses and heater contactors.



Note: Picture only representative of the dryer. Yours may not look exactly the same.

- ❑ **Find the wiring and equipment diagrams that were shipped with your dryer.** These diagrams are the best reference for correcting a problem. The diagrams also will note any custom features, such as special wiring or alarm capabilities, not covered in this User Guide.

A Few Words of Caution

Improper corrective actions can lead to hazardous conditions and should never be attempted to sustain production.



WARNING: Only qualified service personnel should examine and correct problems that require opening the dryer's electrical enclosure or using electrical wires to diagnose the cause.



WARNING: High voltage. Always stop the SlimLine dryer, disconnect and lock out the main power source before troubleshooting or performing repairs.



CAUTION: Hot surfaces. Always protect yourself from hot surfaces inside and outside of the dryer and hopper.

How to Identify the Cause of a Problem

The High Temperature Alarm is indicated by an illuminated Alarm light on the SlimLine control panel and an alarm code, A2.hi is displayed in the control window.

When an alarm code is displayed on the control:

- 1 Find the error message in the diagnostics table** of this troubleshooting section and reference the control sticker in the upper left hand side.
- 2 Note that, after correcting the problem, pressing the Acknowledge Alarm button** will clear the alarm. The alarm will only clear if the condition causing the alarm has been corrected.

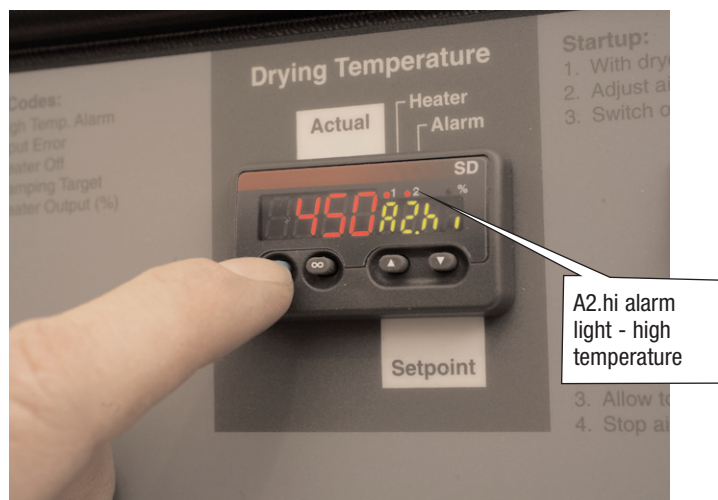

Alarms

A problem can trigger two types of alarms:

- **Latching Alarm** : If the red Alarm LED is on, the alarm is a shutdown alarm. The dryer has automatically shut down because it detected a serious problem that could damage your material or dryer. Note that the Alarm must be acknowledged before the control will resume by pressing the infinity button.  See also [Operation section entitled, *Setting the High Temperature Setpoint.*](#)
- **Cycling Alarm (internal safety devices)**: The dryer has two internal safety devices to avoid overheating. A differential pressure switch which senses that there is low or no air flow and shuts the heater off, and a safety snap switch on the heater, that detects a high heater internal temperature. Both conditions will shut the heater off until the condition goes away or has been corrected, then the control resumes. There is no signal to the operator for this condition.

Problem	Possible cause	Solution
A2.hi (alarm light illuminated) – If the process temperature exceeds the process high temperature setpoint, it shuts down the dryer. Default is set to 450°F (232°C).	One of the process solid state relays has failed.	Replace the solid state relay. See Troubleshooting section entitled, <i>Checking/Replacing Solid State Relays.</i>
	The air lines are restricted or loose.	Straighten any crimps in the hoses. Tighten any loose hoses.
	The process setpoint is higher than the alarm setpoint.	Set the process setpoint higher.
	The process output on the control has failed.	Replace the process controller.
Er.in – Input error	RTD (resistance temperature device) is not providing acceptable range of resistance.	Plug the RTD into the harness. See the wiring diagrams shipped with your machine. Replace the RTD  Note: See the RTD resistance chart to determine if the sensor is bad. See Appendix C.
		Repair electrical connections from the RTD to the controller. See the wiring diagrams shipped with your machine.

Troubleshooting

Problem	Possible cause	Solution
<p>The control is 100% on and the temperatures rises and falls.</p> <p> Press the return button to see the percentage on time of the heater.</p>	<p>Low air flow.</p> <p>The wrong voltage has been supplied to the dryer.</p> <p>The heater has failed.</p>	<p>Increase air flow by turning the regulator knob in a clockwise direction. (Do NOT adjust the air so that the gauge reads in red zone.)</p> <p>Connect the specified voltage. The dryer's voltage appears on the serial plate on the dryer.</p> <p>Replace the heater assembly. See Troubleshooting section entitled, <i>Replacing the heater assembly.</i></p>
<p>The control is 100% on and the temperature does not change - (ramp up or down) /remains at or near ambient.</p>	<p>The differential pressure switch is not functioning properly.</p> <p>Compressed air system is malfunctioning or turned off.</p> <p>Filter(s) in the compressed air system may be clogged.</p> <p>There is low air flow.</p>	<p>Replace the differential pressure switch. See Troubleshooting section entitled, <i>Replacing the differential pressure switch.</i></p> <p>Make sure you are supplying a100 psi {6.9 bar} at the inlet of the dryer. Check this on the recommended installed pressure gauge.</p> <p>Clean or replace the filter(s) on your compressed air system.</p> <p>Increase air flow by turning the regulator knob in a clockwise direction. (Do NOT adjust the air so that the gauge reads in red zone.)</p>

Troubleshooting

Problem	Possible cause	Solution
Temperature doesn't try to reach the set point (ramp up).	Heater fuse failure.	Replace the heater fuse. (fuse located on the bottom.) See the wiring diagrams shipped with your machine. See Troubleshooting section entitled, Replacing fuses.
Control won't light up.	Control fuse failure	Replace the control fuse. (fuse located on the top.) See the wiring diagrams shipped with your machine. See Troubleshooting section entitled, Replacing fuses.
	Rocker (on/off) switch failure.	Replace the rocker (on/off) switch.
	Power not supplied to the unit.	Plug the dryer in to an appropriately sized outlet. See Installation section entitled, Connecting the main power.
	The controller has failed.	Replace the controller.

Removing the Cover on the Dryer

To remove the cover on the dryer:

- 1 Disconnect and lockout the main power.**
- 2 Disconnect the compressed air supply to the dryer.**
- 3 Remove the bolts. There are two (2) bolts located at the top of the dryer cover attaching the dryer's plastic covering to the casting.**



CAUTION: There are wires attaching the control to the dryer's electrical enclosure be careful not to strain the wires.

- 4 Reverse the procedure to reassemble.**



Replacing Fuses

- 1 Unplug the main power supply.**
- 2 Remove the dryer's cover.** See [Troubleshooting section entitled, Removing the cover on the dryer.](#)
- 3 Check the fuse.** If necessary, pull the fuse out and replace it with a fuse of the same type and rating.

 **NOTE:** Fuses have low resistance, if a fuse has infinity resistance it is blown. Fuses must be replaced with a fuse of the same rating.



IMPORTANT: Always refer to the wiring diagrams that came with your dryer to locate specific electrical components. Illustrations in the User Guide are intended to be representative only.



CAUTION: Always disconnect and lock out the main power sources before making electrical connections. Electrical connections should be made only by qualified personnel.

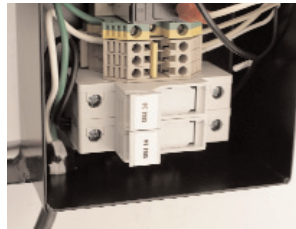

Fuses - in service

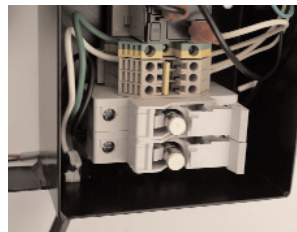

Fuse blocks open for service.

Fuse Blocks

To locate the appropriate fuse and replacement part number, refer to the wiring diagrams that came with your dryer.

Check/Replace Heater Solid State Relays



IMPORTANT: Always refer to the wiring diagrams that came with your dryer to locate specific electrical components. Illustrations in the User Guide are intended to be representative only.



CAUTION: Always disconnect and lock out the main power sources before making electrical connections. Electrical connections should be made only by qualified personnel.

Solid state relay
If ohms equal zero replace the relay.

- 1 Disconnect and lockout the main power supply.**
- 2 Remove the cover on the dryer.** See [Troubleshooting section entitled, *Removing the cover on the dryer.*](#)
- 3 Locate the solid state relay.** Refer to the wiring diagrams that came with your dryer.
- 4 Check resistance using an ohmmeter.** To check with ohm meter, measure the resistance across the terminals.
- 5 Replace the solid state relay, if necessary.** If ohms equal zero replace the solid state relay.

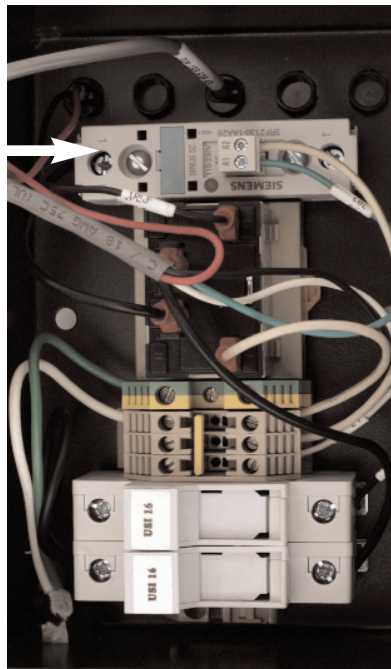

Checking the Heater

1 Unplug the main power supply.



2 Remove the cover on the dryer. See **Troubleshooting section entitled, *Removing the cover on the dryer.***

3 Locate the solid state relay. Refer to the wiring diagrams that came with your dryer.



IMPORTANT: Always refer to the wiring diagrams that came with your dryer to locate specific electrical components. Illustrations in the User Guide are intended to be representative only.

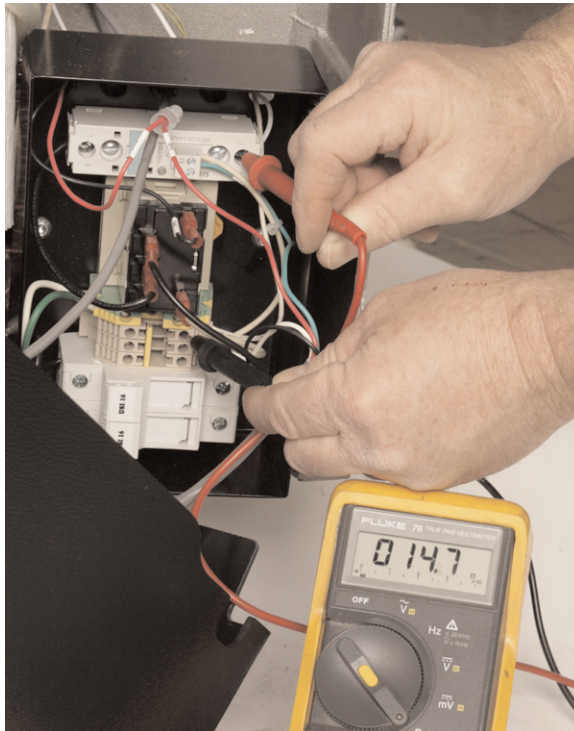

This photo represents an acceptable resistance rating on a 120 volt dryer with a 2 kW heater.

120 volt dryer

Heater	Resistance
1 kW*	5 - 7 Ω
<small>*Models SL2.5, 5 and 15</small>	
2 kW*	10 - 15 Ω
<small>*Models SL25 and 50</small>	

220 volt dryer

Heater	Resistance
1 kW	10 - 15 Ω
<small>*Models SL2.5, 5 and 15</small>	
2 kW	20 - 25 Ω
<small>*Models SL25 and 50</small>	

4 To check with ohm meter, measure the resistance across the heater. See the chart above to determine if the resistance you measured falls within the acceptable specified range for your dryer.

5 Replace the sensor, if necessary.



CAUTION: Always disconnect and lock out the main power sources before making electrical connections. Electrical connections should be made only by qualified personnel.

Replacing the Heater Assembly



CAUTION: Always disconnect and lock out the main power sources before making electrical connections. Electrical connections should be made only by qualified personnel.

1 Disconnect and lockout the main power. If you have mounted a loader or vacuum receiver on the hopper, disconnect the material inlet hose at the source.

2 Disconnect the compressed air supplied to the dryer.

3 Remove the dryer's plastic cover. Remove two screws securing the cover in place. **IMPORTANT!** Be sure to support the cover so that you do not strain the wiring on the back of the control.

4 Unscrew (counter-clockwise) the ring on base of the pressure regulator until the ring comes off. It may be necessary to use channel locks to carefully remove the ring.



5 Disconnect hoses from the pressure switch. Note their location and then disconnect the hose coming from the heater outlet from the low pressure side of the switch and the hose coming from the heater inlet from the high pressure side of the switch. The switch is marked with an “H” for high and an “L” for Low. It will be important to remember these connections for reassembly.

6 Unwire the heater. Note their locations then remove the wires that are connected to the heater. Refer to the wiring diagrams supplied with your unit.

7 Loosen the clamp the connects the supply hose to the casting.



IMPORTANT: Always refer to the wiring diagrams that came with your dryer to locate specific electrical components. Illustrations and photographs in the User Guide are intended to be representative only.

(continued)

Replacing the Heater Assembly (continued)

- 8** Remove the heater assembly. Hold the regulator in place and unthread the heater in a counter-clockwise direction.
- 9** Reverse the procedure to reassemble.
- 10** Check the resistance on the heater before supplying power to the unit. See [Troubleshooting section entitled, *Checking the heater.*](#)

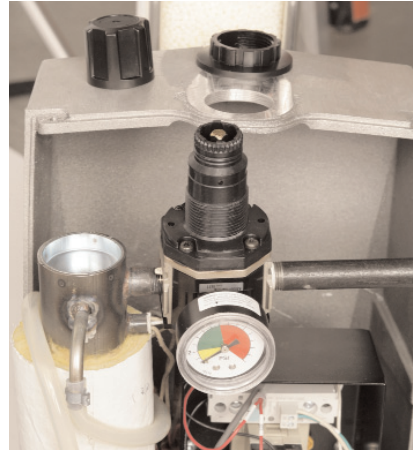

CAUTION: Always disconnect and lock out the main power sources before making electrical connections. Electrical connections should be made only by qualified personnel.

Replacing the Airflow Differential Pressure Switch



CAUTION: Always disconnect and lock out the main power sources before making electrical connections. Electrical connections should be made only by qualified personnel.

- 1 Disconnect and lockout the main power.** If you have mounted a loader or vacuum receiver on the hopper, disconnect the material inlet hose at the source.
- 2 Disconnect the compressed air supplied to the dryer.**
- 3 Remove the dryer's plastic cover.** Remove two screws securing the cover in place. **IMPORTANT!** Be sure to support the cover so that you do not strain the wiring on the back of the control.

- 4 Note their locations, then remove the two spade terminals/wires connected to the pressure switch.** Refer to the wiring diagrams supplied with your unit. It will be important to remember these connections for reassembly.

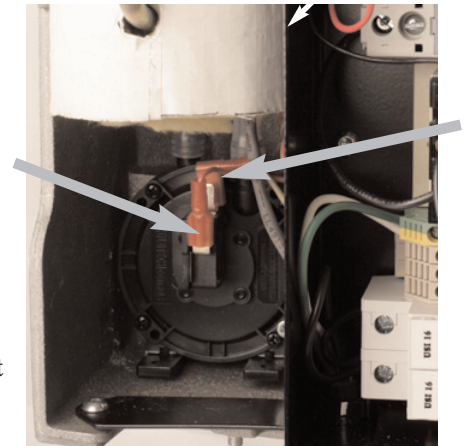

IMPORTANT: Always refer to the wiring diagrams that came with your dryer to locate specific electrical components. Illustrations and photographs in the User Guide are intended to be representative only.

- 5 Note their locations then disconnect hoses from the pressure switch.** Disconnect the hose coming from the heater outlet from the low pressure side of the switch and the hose coming from the heater inlet from the high pressure side of the switch. The switch is marked with an "H" for high and an "L" for Low. It will be important to remember these connections for reassembly.

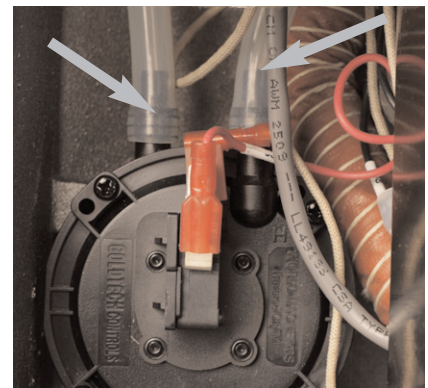

- 6 Remove the mounting hardware securing the pressure switch to the casting.**

Replacing the Airflow Differential Pressure Switch (continued)

- 8** Connect the hose coming from the heater outlet to the low pressure side of the switch and the hose coming from the heater inlet to the high pressure side of the switch.
- 9** Connect the two wires to their original location on the pressure switch.
- 10** Test the system. Make sure that the new air flow differential switch is detecting the pressure drop between the heater inlet and outlet.
- 11** Reinstall the cover on the closure.

IMPORTANT: Always refer to the wiring diagrams that came with your dryer before making electrical connections.



CAUTION: Always disconnect and lock out the main power sources before making electrical connections. Electrical connections should be made only by qualified personnel.

We're Here to Help

Conair has made the largest investment in customer support in the plastics industry. Our service experts are available to help with any problem you might have installing and operating your equipment. Your Conair sales representative also can help analyze the nature of your problem, assuring that it did not result from misapplication or improper use.

Additional manuals and prints for your Conair equipment may be ordered through the Customer Service or Parts Department for a nominal fee. Most manuals can be downloaded free of charge from the product section of the Conair website.
www.conairnet.com.

How to Contact Customer Service

To contact Customer Service personnel, call:



 **NOTE:** Normal operating hours are 8:00 am - 5:00 PM. After hours emergency service is available at the same phone number.

From outside the United States, call: 814-437-6861

You can commission Conair service personnel to provide on-site service by contacting the Customer Service Department.

Before You Call...

If you do have a problem, please complete the following checklist before calling Conair:

- Make sure you have all model, serial and parts list numbers for your particular equipment. Service personnel will need this information to assist you.
- Make sure power is supplied to the equipment.
- Make sure that all connectors and wires within and between control systems and related components have been installed correctly.
- Check the troubleshooting guide of this manual for a solution.
- Thoroughly examine the instruction manual(s) for associated equipment, especially controls. Each manual may have its own troubleshooting guide to help you.
- Check that the equipment has been operated as described in this manual.
- Check accompanying schematic drawings for information on special considerations.

Equipment Guarantee

Conair guarantees the machinery and equipment on this order, for a period as defined in the quotation from date of shipment, against defects in material and workmanship under the normal use and service for which it was recommended (except for parts that are typically replaced after normal usage, such as filters, liner plates, etc.). Conair's guarantee is limited to replacing, at our option, the part or parts determined by us to be defective after examination. The customer assumes the cost of transportation of the part or parts to and from the factory.

Performance Warranty

Conair warrants that this equipment will perform at or above the ratings stated in specific quotations covering the equipment or as detailed in engineering specifications, provided the equipment is applied, installed, operated and maintained in the recommended manner as outlined in our quotation or specifications.

Should performance not meet warranted levels, Conair at its discretion will exercise one of the following options:

- Inspect the equipment and perform alterations or adjustments to satisfy performance claims. (Charges for such inspections and corrections will be waived unless failure to meet warranty is due to misapplication, improper installation, poor maintenance practices or improper operation.)
- Replace the original equipment with other Conair equipment that will meet original performance claims at no extra cost to the customer.
- Refund the invoiced cost to the customer. Credit is subject to prior notice by the customer at which time a Return Goods Authorization Number (RGA) will be issued by Conair's Service Department. Returned equipment must be well crated and in proper operating condition, including all parts. Returns must be prepaid.

Purchaser must notify Conair in writing of any claim and provide a customer receipt and other evidence that a claim is being made.

Warranty Limitations

Except for the Equipment Guarantee and Performance Warranty stated above, Conair disclaims all other warranties with respect to the equipment, express or implied, arising by operation of law, course of dealing, usage of trade or otherwise, including but not limited to the implied warranties of merchantability and fitness for a particular purpose.

Determining Airflow in the SlimLine Dryer

Optimizing your compressed air consumption is critical to energy savings.

There are two main ways to determine your compressed air usage:

1. Relate the heater inlet pressure to the airflow. (accuracy is limited)
2. Calculate the airflow by using specific heat and the differential temperature of the air through the heater.

Relating the Heater Inlet Pressure to the Air Flow

Determining your compressed air usage by this method is limiting because the CFM readings are based on an empty hopper. When material is present in the hopper the airflow drops below the charts specified pressure due to the additional airflow restriction caused by the material. This measurement does provide a useful estimate, but is not precise because all material does not produce the same air flow restriction.

To use the relationship between the heater inlet pressure and air flow to determine your compressed air usage:

- 1 Read the inlet pressure on the pressure gauge of the SlimLine dryer.**
There are marks indicating the regulated pressure in PSI on the regulator. The green range is 2-7 psi {0.14 - 0.48 bar}
- 2 Use the chart on the right to relate your reading to the airflow listed in the chart.**

SlimLine Model	Pressure Applied (PSI)	Measured Flow SCFM
SL2.5 and SL5	2	2.0
	3	2.9
	4	3.7
	5	4.5
	6	5.0
SL15	7	5.3
	2	6.17
	3	7.42
	4	8.5
	5	9.0
SL25 and SL50	6	9.5
	7	10
	2	16
	3	18
	4	21
	5	23
	6	26
	7	27

Calculating the Airflow through the Hopper to Specify the Mass of Air

The most accurate way calculate your airflow is to determine how much the temperature is increased by the actual heat input.

To specify the mass or air use the following equation:

$Q = M * C * (T_{out} - T_{in})$ where Q is the heat input, M is the mass of the air, C is the specific heat or air and T_{in} , T_{out} are the temperature in and out of the heater respectively.

Then rearranging and adding units:

1 $SCFM = (\% \text{ on} * Kw * 3413) / (0.075 * 60 * 0.24 * (T_{out} - T_{in})) / 100$

2 $SCFM = (\% \text{ on} * 31.08 / T_{out} - T_{in})$ for the SL 2.5/5/15

3 $SCFM = (\% \text{ on} * 62.16) / (T_{out} - T_{in})$ for the SL25/50



NOTE:

The percent (%) on number can be read from the first menu displayed on the controller, by pressing the green return button one (1) time. This number should only be read after the unit has had time to stabilize at the setpoint temperature.

T_{out} (temperature out)- the setpoint temperature (°F)

T_{in} (temperature in) - The compressed air supply temperature to the dryer (usually close to the ambient temperature) (°F)

SCFM - Air flow in cubic feet per minute of air at standard density (0.075 lb/ft³).

RTD resistance chart

You can use the following chart to determine if you need to replace your RTD.

Temp °F	+ 0	+ 1	+ 2	+ 3	+ 4	+ 5	+ 6	+ 7	+ 8	+ 9
0	93.0334	93.2517	93.4699	93.6881	93.9063	94.1244	94.3425	94.5605	94.7786	94.9965
10	95.2145	95.4324	95.6503	95.8681	96.0859	96.3036	96.5214	96.7390	96.9567	97.1743
20	97.3919	97.6094	97.8269	98.0444	98.2618	98.4792	98.6966	98.9139	99.1312	99.3485
30	99.5657	99.7829	100.0000	100.217	100.434	100.651	100.868	101.085	101.302	101.519
40	101.736	101.953	102.169	102.386	102.603	102.820	103.036	103.253	103.469	103.686
50	103.903	104.119	104.335	104.552	104.768	104.985	105.201	105.417	105.633	105.849
60	106.066	106.282	106.498	106.714	106.930	107.146	107.362	107.578	107.794	108.009
70	108.225	108.441	108.657	108.872	109.088	109.304	109.519	109.735	109.950	110.166
80	110.381	110.596	110.812	111.027	111.242	111.458	111.673	111.888	112.103	112.318
90	112.533	112.748	112.963	113.178	113.393	113.608	113.823	114.038	114.253	114.468

Temp °F	+ 0	+ 1	+ 2	+ 3	+ 4	+ 5	+ 6	+ 7	+ 8	+ 9
100	114.682	114.897	115.112	115.326	115.541	115.755	115.970	116.184	116.399	116.613
110	116.828	117.042	117.256	117.470	117.685	117.899	118.113	118.327	118.541	118.755
120	118.969	119.183	119.397	119.611	119.825	120.039	120.253	120.466	120.680	120.894
130	121.107	121.321	121.535	121.748	121.962	122.175	122.389	122.602	122.815	123.029
140	123.242	123.455	123.668	123.882	124.095	124.308	124.521	124.734	124.947	125.160
150	125.373	125.586	125.799	126.011	126.224	126.437	126.650	126.862	127.075	127.288
160	127.500	127.713	127.925	128.138	128.350	128.563	128.775	128.987	129.200	129.412
170	129.624	129.836	130.049	130.261	130.473	130.685	130.897	131.109	131.321	131.533
180	131.744	131.956	132.168	132.380	132.592	132.803	133.015	133.227	133.438	133.650
190	133.861	134.073	134.284	134.496	134.707	134.918	135.130	135.341	135.552	135.763

Compressed Air Membrane Option

This option is necessary when the compressed air supplied does not meet the 40° F {4° C} dewpoint. The membrane serves as a refrigerant air conditioner and reduces the dewpoint to the 40° F {4° C} dewpoint specification. The included filters aid in cleaning the compressed air.

Replacement filters are available from Conair.

Contact Conair Parts
1 800 458 1960
From outside of the United States, call:
814 437 6861



CAUTION: Air under high pressure

This equipment uses compressed air delivered at rates up to 150 PSI {10.3 bar} to dry plastic materials.

To prevent possible injury, wear eye protection when operating this equipment. Always disconnect the compressed air supply before performing maintenance or troubleshooting.

The membrane is specifically designed to remove water vapor. Dryer performance and life will be reduced if liquid water or liquid compressor oil enters the dryer. Filter(s) must be installed in front of the dryer to remove both liquid water and oil aerosols if present in your plant's compressed air system.

Preparing to Install the Membrane

- 1 The membrane assembly can be used with oil lubricated, water lubricated or non-lubricated compressors.**
- 2 Always install a drainable drip leg prior to the inlet filtration to the membrane assembly.** This helps prevent the accumulation of water at low points that could overwhelm the water handling capability of the filter.
- 3 Before installing the membrane assembly verify that:**
 - a. The maximum pressure that could be encountered is less than the dryer 150 psi {10.3 bar} and filter rated pressure.
 - b. The compressed air supply temperature and ambient temperature at the membrane assembly will not exceed 150° F {66° C}.
 - c. The dryer sweep air (located at the bottom of the longest membrane container) will not be obstructed.
 - d. The line sizes are adequate for the air flow and allowable pressure drop (Adequate size would be the same size as dryer or larger.)

(continued)

Preparing to Install the Membrane (continued)

4 The membrane option and any related prefiltration equipment is designed to be mounted in a vertical position. In most cases, we do not recommend supporting the module with the process piping. We recommend piping supports be located on either side of, directly in front of, or behind the dryer and filters. Support brackets are supplied with the membrane assembly to simplify your installation.

 **NOTE:** It is important for maximum membrane life, that the appropriate filtration system be used with the membrane and the dryer. Proper prefiltration will ensure the effective removal of particulates, water, compressor lubricant oil, and other types of contaminants. This is best accomplished by the use of the integrated pre-filtration. Damage to the membrane and/or the dryer or dew point degradation may result if the prefiltration is removed or relocated at a distance away from the installation.

Using the Wall Mount Brackets to Mount the Membrane Assembly

The membrane assembly is supplied with wall mounting brackets. If you choose to use the supplied mounting brackets:

1 Mount bracket to filter head. Remove four (4) screws holding black plastic top cap to filterhead. Then, place bracket on filter head over plastic cap. Install screw supplied with bracket.



 **CAUTION:** You are responsible for the structural integrity of this installation.

Mounting the Differential Pressure Gauge to the Filterhead (if not factory installed)

- 1** Make certain o-rings are in place on the bottom of the gauge body.
- 2** Connect the low pressure transmission bolt (bolt next to the red band on gauge) to the gauge port at the filter outlet (downstream side of the filter).
- 3** Connect the high pressure transmission bolt (bolt next to green band on gauge) to the gauge port at the filter inlet (upstream side of filter).
- 4** Use a flathead screwdriver to tighten/loosen bolts. The tip width of the screwdriver should be a least 3/8 inch {9.5 mm}. Torque bolts to 25 +/- 5 inch oz. Do not overtighten.



CAUTION: Air under high pressure

This equipment uses compressed air delivered at rates up to 150 PSI to dry plastic materials.

To prevent possible injury, wear eye protection when operating this equipment. Always disconnect the compressed air supply before performing maintenance or troubleshooting.

Installing the compressed air piping for membrane assembly installation

- 1** Before installing, blow out pipe line to remove scale and other foreign matter.
- 2** Mount so that inlet and outlet connections are horizontal (filter bowl vertical) to ensure proper liquid drainage.

IMPORTANT: You should not use threaded sealant tape on the compressed air connections. Use of these items can contaminate your compressed air circuit. A quick disconnect fitting may be used to facilitate easy air line connection and removal for the main supply line, but the fitting should not be the type that restricts air flow.

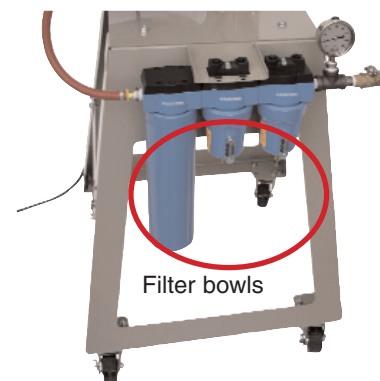

(continued)

Installing the compressed air piping for membrane assembly installation (continued)

- 4 Install so that the air flow direction is in the direction of arrows on the filterhead.

NOTE: Make certain flow direction through filters is correct (observe pin hole used for aligning top caps). When hole is on side closest to you, inlet is to left.

- 5 For ease of service, Conair recommends that an isolation valve (not included) is installed on the compressed air line leading to the membrane assembly.

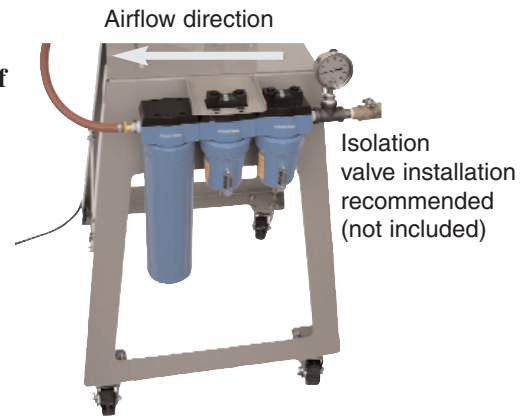

Membrane Installation

- 1 A typical membrane assembly installation is shown below.



CAUTION: Always wear protective eyewear when working with compressed air.

Membrane Installation (continued)



WARNING: Disconnect power and compressed air before servicing.

Always disconnect and lock out power and compressed air supplies to this equipment before performing maintenance or repair. Failure to do so could result in personal injury caused by the unexpected energizing of this equipment.

2 Prior to installing the membrane, slowly open the compressed airline shut off valve and relieve any accumulated pressure. Allow any accumulated water, oil, or particulates to blow out. **Use extreme caution to prevent accidents and injuries during this operation.**

3 Disconnect and isolate the compressed air supply leading to the area where you will be installing the membrane. If you are installing the membrane onto an existing dryer installation make sure that you disconnect and lock out the main power supplied to the dryer.



CAUTION: Air under high pressure

This equipment uses compressed air delivered at rates up to 150 PSI to dry plastic materials.

To prevent possible injury, wear eye protection when operating this equipment. Always disconnect the compressed air supply before performing maintenance or troubleshooting.

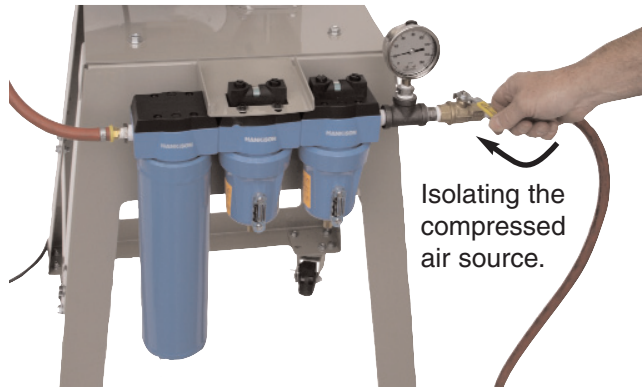

4 Connect the compressed air supply to the filter. The coalescing filter should be as close to the dryer as practical to prevent cooling of the air and condensation of water and oil between the coalescing filter and the dryer. An isolation/shut-off valve (ball or gate valve) the same size as the supply line should be installed before the filter and dryer so that the dryer and application can be isolated.



Connecting the compressed air supply.

Membrane Installation (continued)

- 5** Connect the compressed air supply (dry air outlet) to the SlimLine.

Connecting the compressed air supply from the filter to the dryer.

- 6** The automatic filter drains may discharge oil and water. Route the filter drain line to a suitable location in compliance with local regulations.

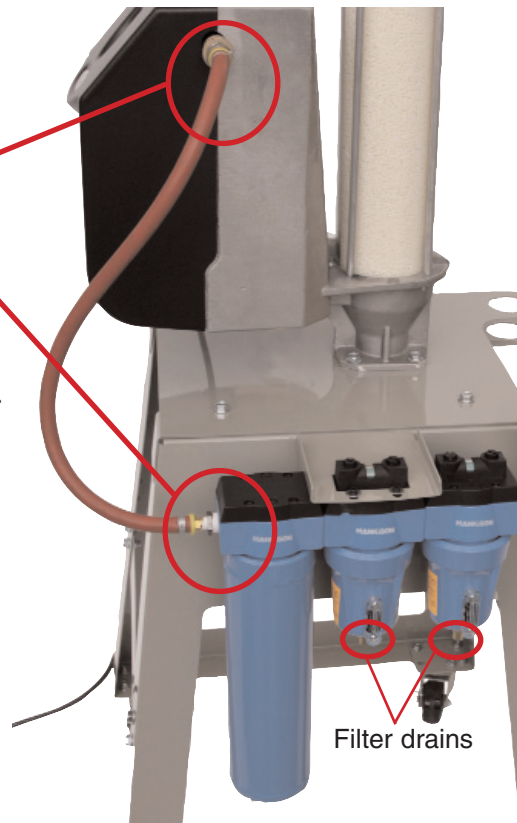



CAUTION: Air under high pressure

This equipment uses compressed air delivered at rates up to 150 PSI {10.3 bar} to dry plastic materials.

To prevent possible injury, wear eye protection when operating this equipment. Always disconnect the compressed air supply before performing maintenance or troubleshooting.

Start-up and Operation

1 Slowly open up the upstream isolation valve compressed air supply to the dryer/membrane unit. Maximum pressurization rate of 15 psi/sec. Check for any possible leaks. Listen, and feel for leaks, you can use a bubble soap solution to help locate possible leaks. **IMPORTANT:** Do not operate filter at pressures in excess of the maximum working pressure of 150 psi.

 **NOTE:** Prefilters: The automatic drain may leak air until the pressure builds up to about 10 psi {0.69 bar} and will then seal except when discharging accumulated water and oil.

2 The filter differential pressure indicator(s) and drain(s) should be inspected on a regular schedule, preferably as least weekly. If the filter differential pressure indicator enters the red area on either the prefilter or coalescing filter, both of the filter element(s) must be changed. It is recommended that replacement filter elements be kept on hand as spares for fast change-outs to eliminate down time.

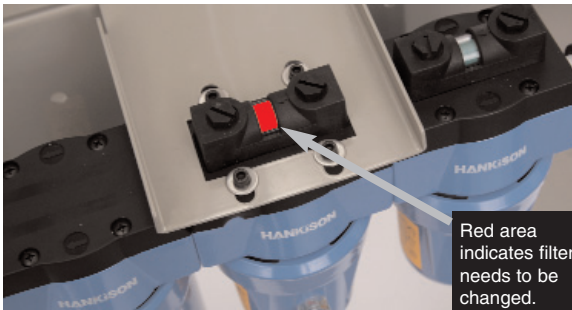

Smaller-sized membrane assemblies come equipped with the filter differential pressure indicator shown above. The red area on the prefilter indicates that both filter elements should be changed.

 **NOTE:** If filter life remains less than six months with a prefilter installed, compressor maintenance or excessive line corrosion and/or contamination is indicated.

 **NOTE:** If any decrease is observed in the drain rate, the filter should be depressurized and the bowl removed. If the liquid level in the bowl is above the automatic drain float, the automatic drain is not operating correctly and should be replaced.



Larger-sized membrane assemblies come equipped with the filter differential pressure indicator shown above. If either the prefilter or the coalescing filter enter the red area both filter elements should be changed.

Start-up and Operation (continued)

- 3** Filter element(s) should be replaced on a regular schedule (preferably every six months). See [Appendix D](#) section entitled, *Filter Element Replacement*.
- 4** To shutdown the membrane assembly turn off the air supply and allow the pressure to decrease to atmospheric. Maximum de-pressurization of 15 psi/sec.

IMPORTANT: Do not operate filter at pressures in excess of the maximum working pressure of 150 psi.

 **NOTE:** Maximum operating temperature of the membrane assembly is 150° F {38° C}.

Maintenance and Troubleshooting



WARNING: Disconnect power and compressed air before servicing.

Always disconnect and lock out power and compressed air supplies to this equipment before performing maintenance or repair. Failure to do so could result in personal injury caused by the unexpected energizing of this equipment.

The only routine maintenance required is replacement of the filter element(s) every six months and rebuilding or replacing the drain mechanism annually. There are no repairable components within the membrane. The membrane must be replaced if damaged or oil soaked.

To ensure performance of the membrane and to obtain maximum compressor life, all compressor maintenance schedules recommended by the compressor manufacturer should be followed.

Maintenance/Troubleshooting Checkpoints

Check flow, pressure, and temperature to make certain filter is being operated within design conditions.

- **High dewpoint** - Before attempting to troubleshoot the membrane verify that the dry air flow rate is at or below the design level of the membrane assembly (150 psi {10.3 bar}). High air flow will result in high dew points.

The most likely cause of the high dew point is low air supply pressure, due to either low pressure to the filters or high pressure drop across the filters. The latter will be indicated by the filter differential pressure indicator.

Another possible cause of high dew point is failure of the automatic drains. Manually open the drain.

 **NOTE:** Pressure drop should never exceed 50 psi {3.4 bar}.

- **Check pressure drop across the filter**
Pressure differential in excess of 6 psi {0.41 bar} or pressure indicator in red area means that the filter sleeve or element should be replaced.
- **Check for sudden reduction in pressure drop.**
This might indicate: A possible leak across element o-ring seal or a leak through the element due to physical damage.
- **Check to see that filter is installed level to ensure proper drainage.**
- **Check that manual drains are drained periodically or that automatic drains are functioning.**
- **On models with liquid level sight glass check that liquid level is below top of sight glass.**

Filter Elements

If the filter differential pressure indicator shows red, filter elements must be changed. Continuing to operate for an extended period after the filter differential pressure indicator(s) have changed completely to red could result in low air pressure, high dew points, and eventually in failure of the filter element leading to contamination and damage of the dryer.

If filter element life remains less than six months with a prefilter installed, compressor maintenance or excessive line corrosion or contamination is indicated.

When to Replace a Filter Element

- a. Initial (dry) pressure drop: 1 psi {0.07 bar} to 2 psi {0.14 bar}.
- b. Operating pressure drop: As filter becomes liquid loaded (wetted), pressure drop will increase to 2 to 6 psi {0.14 bar to 0.41 bar}. Further pressure drop occurs as element loads with solid particles.



NOTE: Pressure drop may temporarily increase when flow is resumed after flow stoppage. Pressure drop should return to normal within one hour.

Filter Element Replacement

This filter is a pressure containing device. Depressurize before servicing isolate and completely depressurize filter before proceeding.



WARNING: Disconnect power and compressed air before servicing.
Always disconnect and lock out power and compressed air supplies to this equipment before performing maintenance or repair. Failure to do so could result in personal injury caused by the unexpected energizing of this equipment.

(continued)

Filter Element Replacement



WARNING:

Disconnect power and compressed air before servicing.

Always disconnect and lock out power and compressed air supplies to this equipment before performing maintenance or repair. Failure to do so could result in personal injury caused by the unexpected energizing of this equipment.

- 1 Isolate filter close inlet and outlet valves if installed or shutoff air supply.**



- 2 Depressurize filter by slowly opening drain valve manually.**



- 3 Remove the bowl.** Push the bowl up, turn bowl 1/8 turn to your left, and pull bowl straight down.



(continued)

Filter Element Replacement (continued)

4 Remove the filter elements. Pull off old element and discard.



This is an example of a smaller-sized membrane disassembled.



This is an example of a large-sized membrane disassembled.

Replacement filters are available from Conair.

Contact Conair Parts
1 800 458 1960

From outside of
United States, call:
814 437 6861

5 Clean filter bowl. The filter bowl and automatic drain should be washed with warm soapy water to remove any accumulated oil.

6 Replace the filter element. Make certain the o-ring inside the top of the replacement filter element is in place and push the filter element onto the filterhead.

(continued)

Filter Element Replacement (continued)

7 After making certain that o-ring inside top of bowl and the wave spring are in place, reassemble bowl to head.

 **NOTE:** Do not handle elements by outside foam cover. Handle by bottom end cap only.

 **NOTE:** Make certain o-ring is generously lubricated.

 **NOTE:** Wave spring ends should be pointed down to prevent wave spring from interfering with reassembly.

Automatic Draining Mechanism

 **NOTE:** Collected liquids must be removed to ensure proper operation.

 **NOTE:** Depressurize slowly, to avoid filter element damage.

1 Membrane assemblies are equipped with automatic drains. Liquids will automatically discharge when a sufficient accumulation occurs. These drains may be manually drained by turning to your right (clockwise) to open and to your left (counterclockwise) to close.

◆ **Tip:** Manually drain internal auto drains daily to verify drain function.

◆ **Tip:** It is recommended that drain mechanism be replaced annually.

IMPORTANT: If a high water level is observed in a filter liquid level indicator, the automatic drain is not functioning correctly. The dryer should be shut down and the drain mechanism should be repaired or replaced before proceeding. Extended operation with malfunctioning automatic drain(s) could result in liquid water and oil entering the dryer, resulting in elevated dew points and damage to the membrane assembly and/or dryer.

Drain Provisions

The bottom of internal automatic drains are provided with 1/8 inch (inside threads) for connection of a drain line if desired.

Discharge is at system pressure; anchor drain line