

USER GUIDE
UGD052-0914

MicroWheel

MW1 Model



Please record your equipment's model and serial number(s) and the date you received it in the spaces provided.

It's a good idea to record the model and serial number(s) of your equipment and the date you received it in the User Guide. Our service department uses this information, along with the manual number, to provide help for the specific equipment you installed.

Please keep this User Guide and all manuals, engineering prints and parts lists together for documentation of your equipment.

Date:

Manual Number: UGD052-0914

Serial Number(s):

Model Number(s):

DISCLAIMER: Conair shall not be liable for errors contained in this User Guide or for incidental, consequential damages in connection with the furnishing, performance or use of this information. Conair makes no warranty of any kind with regard to this information, including, but not limited to the implied warranties of merchantability and fitness for a particular purpose.

Table of Contents

1 - 1 Introduction

Purpose of the User Guide	1-2
How the Guide Is Organized.....	1-2
Your Responsibilities as a User	1-2
ATTENTION: Read this so no one gets hurt.....	1-3
Safety Rules	1-4
How to Use the Lockout Device	1-5

2 - 1 Description

What is the Conair MicroWheel MW1?	2-2
Typical Applications.....	2-2
How the MicroWheel MW1 Works.....	2-6
Specifications: MicroWheel MW1.....	2-7
Throughputs: MicroWheel Models MW1 and MW2.....	2-8

3 - 1 Installation

Unpacking the Boxes.....	3-2
Installing the MicroWheel MW1	3-4
Regeneration Discharge Pipe.....	3-6
Electrical Connections	3-7
Control Panel	3-7

4 - 1 Operation

Routine Start Up	4-2
Machine Configuration Setup	4-7

5 - 1 Maintenance

Safety Rules for Adjustment, Servicing and Troubleshooting Procedures	5-2
Particular Checks In Case of Molding Problems	5-3
Cleaning the Cooling Elements	5-5

6 - 1 Troubleshooting

Before Beginning.....	6-2
A Few Words of Caution.....	6-2
Alarm & Warning List & Troubleshooting	6-3
Material Database	6-4
Spare Parts	6-5
Decommissioning The Machine	6-5
Electrical Wiring	6-6
Descriptions.....	6-11

A Appendix

Customer Service Information	A-1
Warranty Information.....	A-2

Introduction

Purpose of the User Guide	1-2
How the Guide Is Organized	1-2
Your Responsibilities as a User	1-2
ATTENTION: Read This So No One Gets Hurt.....	1-3
Safety Rules.....	1-4
How to Use the Lockout Device	1-5

Purpose of the User Guide

This User Guide describes the Conair MicroWheel MW1 and explains step-by-step how to install and operate this equipment.

Before installing this product, please take a few moments to read the User Guide and review the diagrams and safety information in the instruction packet. You also should review manuals covering associated equipment in your system. This review won't take long, and it could save you valuable installation and operating time later.

How the Guide is Organized

Symbols have been used to help organize the User Guide and call your attention to important information regarding safe installation and operation.



Symbols within triangles warn of conditions that could be hazardous to users or could damage equipment. Read and take precautions before proceeding.



Numbers indicate tasks or steps to be performed by the user.



A diamond indicates the equipment's response to an action performed by the user.



An open box marks items in a checklist.



A circle marks items in a list.



Indicates a tip. A tip is used to provide you with a suggestion that will help you with the maintenance and the operation of this equipment.



Indicates a note. A note is used to provide additional information about the steps you are following throughout the manual.

Your Responsibility as a User

You must be familiar with all safety procedures concerning installation, operation, and maintenance of this equipment. Responsible safety procedures include:

- Thorough view of this User Guide, paying particular attention to hazard warnings, appendices, and related diagrams.
- Thorough review of the equipment itself, with careful attention to voltage sources, intended use and warning labels.
- Thorough review of instruction manuals for associated equipment.
- Step-by-step adherence to instructions outlined in this User Guide.

ATTENTION: Read This So No One Gets Hurt

We design equipment with the user's safety in mind. You can avoid the potential hazards identified on this machine by following the procedures outlined below and elsewhere in the User Guide.



WARNING: Improper installation, operation, or servicing may result in equipment damage or personal injury.



This equipment should be installed, adjusted, and serviced by qualified technical personnel who are familiar with the construction, operation, and potential hazards of this type of machine.

All wiring, disconnects, and fuses should be installed by qualified electrical technicians in accordance with electrical codes in your region. Always maintain a safe ground. Do not operate the equipment at power levels other than what is specified on the machine serial tag and data plate.



WARNING: Voltage hazard



This equipment is powered by single-phase current, as specified on the machine serial tag and data plate.

A properly sized conductive ground wire from the incoming power supply must be connected to the chassis ground terminal inside the electrical enclosure. Improper grounding can result in severe personal injury and erratic machine operation.

Always disconnect and lock out the incoming main power source before opening the electrical enclosure or performing non-standard operating procedures, such as routine maintenance. Only qualified personnel should perform troubleshooting procedures that require access to the electrical enclosure while power is on.

Safety Rules

- 1** Failure to observe the basic rules of accident prevention and safety is one of the main causes of accidents when using and servicing industrial machinery.
- 2** Before performing any operation on the machine you must carefully read this manual, the safety rules below and the information given on the warning notices affixed to the machine. Do not allow unauthorized personnel to use, adjust or repair the machine.
- 3** In the design and manufacture of the machine and the writing of the instruction manual, all attempts have been made to eliminate or reduce the hazards for those who install, use or repair the machine. If you come across any further potentially hazardous conditions, please inform the manufacturer, who will take measures to remedy the problem.
- 4** When required, all persons working on the machine must wear protective clothing (helmets, safety footwear, gloves, earplugs or hearing defenders, safety goggles etc.) in accordance with international workplace safety standards.
- 5** Only persons with adequate technical training, who have a complete working knowledge of the machine, who have the necessary physical and psychological requirements for working safely on the machine, and who have fully read the supplied documentation are allowed to operate the machine and perform routine maintenance tasks on it.
- 6** Set up footboards or platforms (in accordance with the safety regulations in force) when installing parts that cannot be reached from ground level.
- 7** When interfacing with other machinery, strictly observe the instructions given by the manufacturers of the other machines.
- 8** Check that the safety systems (guards, micro switches, sensors) are in perfect working order before starting work. Any parts that are not in perfect working order must be repaired before proceeding. It is strictly forbidden to remove safety devices, tamper with the electrical system or any of the mechanisms.
- 9** This machine must be used for the purpose for which it was designed. Improper use of the machine is strictly prohibited.
- 10** Do not touch the machine with your hands or any other parts of the body if they are wet or damp.

The manufacturer cannot be held responsible for any injury to persons or damage to property resulting from the non-observance of the above safety rules.

These rules supplement but do not replace the statutory industrial accident prevention regulations in force in the country where the machine is installed.

ALLOWED USE: Air drying of plastic pellets with the purpose of removing the moisture before the molding of plastics items. Plastic polymers similar to the one described in the inside database of the control of the unit.

NOT ALLOWED USE: Everything different from drying plastic pellets and particularly: Drying with different gas other than air especially flammable ones, drying fine powder or liquid, drying vapors different from moisture, heating up flammable elements, or using the air stream to blow away objects.

How to Use the Lockout Device



CAUTION: Before performing maintenance or repairs on this product, you should disconnect and lockout electrical power sources to prevent injury from unexpected energization or start-up. A lockable device has been provided to isolate this product from potentially hazardous electricity.



WARNING: Before removing lockout devices and returning switches to the ON position, make sure that all personnel are clear of the machine, tools have been removed and all safety guards reinstalled.

Lockout is the preferred method of isolating machines or equipment from energy sources. Your Conair product is equipped with the lockout device pictured below. To use the lockout device:

- 1 Stop and allow proper shutdown.**
- 2 Isolate the equipment from the electric power.**
- 3 Turn the rotary disconnect switch to the OFF, or “O” position**
- 4 Secure the device with an assigned lock or tag.**
- 5** The equipment is now locked out.

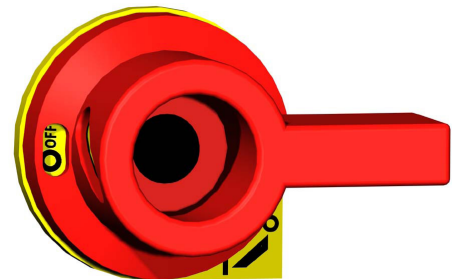

Figure 1



Figure 2

Description

What is the Conair MicroWheel MW1 2-2

Typical Applications 2-2

How the MicroWheel MW1 Works 2-6

Specifications: MicroWheel MW1 2-7

Throughputs: MicroWheel Models MW1 and MW2..... 2-8

What is the Conair MicroWheel MW1?

The Conair MicroWheel MW1 is a dryer used for drying plastic pellets with the purpose of removing the moisture before the molding of the plastic items.

The MicroWheel MW1 is equipped with a rotating wheel made with molecular sieves, with high moisture absorption capacity

The MicroWheel MW1 is equipped with a control panel with a blue LCD graphic display and four control keys to control the dryer

Typical Applications

Special Features and Options

The dryer can be equipped with components that allow it to work with additional advanced features. A stand alone application could be as shown in [Figure 3](#). The dryer 3 works with a hopper 4 and control the drying hopper loader 1 to load the material from a bulk container 7. On the material discharge of the hopper 8 the dried plastics pellets is conveyed through a pipe 10 to the machine hopper loader 2 which fills a small maintenance hopper on the IMM or extruder 6. A proportional valve 9 can be installed to mix the main material with, for example, a just regrinded material from the grinder 12.

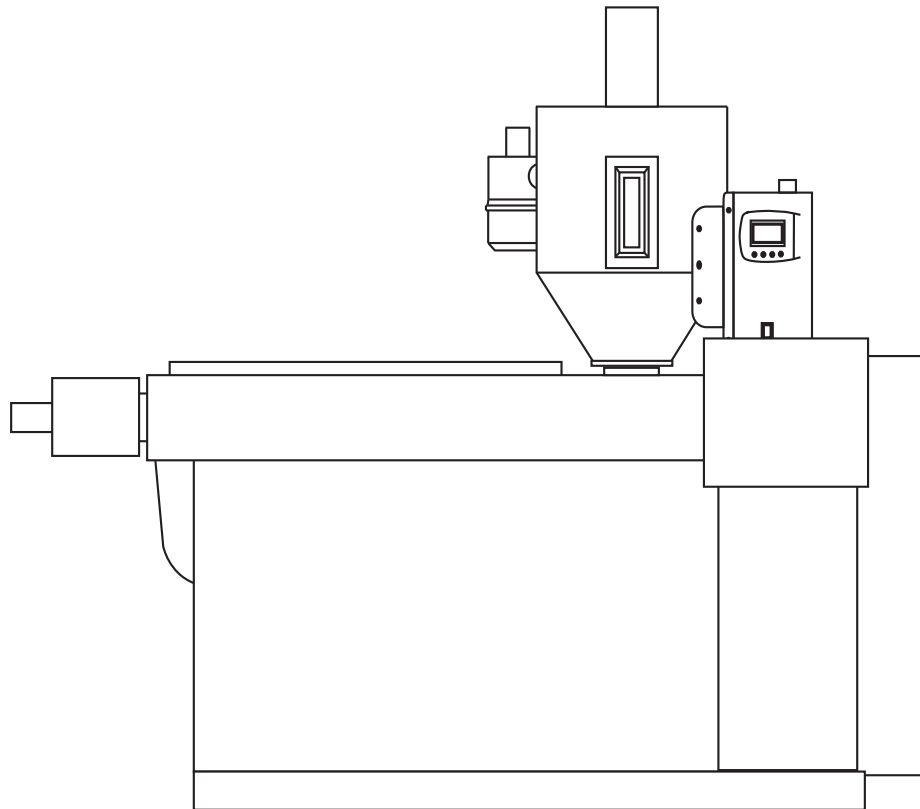

Figure 3

Typical Applications (Continued)

Proportional Valve

The proportional valve, item 9 in Figure 3, is a special optional motorized valve controlled by the dryer 3 that allows a mix of two different materials in the desired percentage. The proportion between the two materials is reached by dividing the suction time through pipe 10 and 11 according to the percentage required. For example if the total suction time is 20 seconds and the regrind percentage is 25% the suction time will be 5 seconds for the regrind and 15 seconds for the main material. Additionally it can use more than a proportional cycle for each charge, for example with 2 cycle the regrind sucking time will be 2.5 seconds then 1.7 seconds main material then 2.5 seconds regrind then last 7.5 seconds of the main material. Increasing the cycle time will also increase the homogeneity of the two materials but will lower the convey efficiency so it's important to regulate the cycle number with just the minimum value needed.

The proportional valve is normally installed in the IMM hopper loader (#2) because it is used to recycle the just made regrind material from the grinder. In case the grinder material is not used but just produced the same hour later we recommend installing the proportional valve in the drying hopper loader to allow the grinder material to be dried again since the moisture level inside it has increased. This must be done by a qualified technician because the software configuration is different if installed on hopper loader 1 or 2. *For more information about more accurate time scale and procedures, please consult the plastic material producer data sheet in the “drying” section.*

Line Cleaning Valve

The line cleaning valve is a special optional motorized valve that is used to keep the pipe 10 empty that charges the hopper loader 2 on the IMM or extruder machine. The purpose of keeping the inside of the pipe 10 empty of granular material is to avoid any contamination or cooling down inside the pipe between two charges of the hopper loader. Additionally the pneumatic convey is better because the fluidification of the material in the air stream is more constant. The dryer control will manage one cleaning valve through the electronic board output O6 but the installation, if not ordered in the supply, must be done by a qualified assistance service because the software has to be configured.

As an alternative of the line cleaning valve the dryer could manage a discharge hopper valve installed before the suction valve 8. This valve closes the bottom discharge part of the hopper to avoid the granular material from falling down in the suction valve 8 before the drying time is elapsed, but this only works if the SLS system is enabled. *See Safety Loading System SLS in this Section of the manual.*

Dew point sensor

An optional 4-20 ma dew point sensor transmitter can be installed in the dryer to monitor the value of dew point of the process air and to give out a warning if the real dew point is not within the setpoint. When the probe is installed the dryer uses the reading to feedback the dew point regulation system to accurately regulate it to the wanted value. The display will show the read value when the dryer is working.

To work properly the dew point transmitter has to be installed by qualified personnel. Please contact your service department to have it installed aftermarket.

Contact Conair for specific recommendations for your product.

Contact Conair Customer Service
1 800 458 1960.
From outside of the United States,
call: 814 437 6861

Typical Applications (Continued)

MPM

The Material Protection Management is a special feature that protects the material against over drying and thermal degradation if the production of the IMM or extruder is stopped for long time. There are two different systems:

1 By hopper loader cycles counting

To work, it needs the presence of the hopper loader (#1) on the drying hopper because controlling the loading frequency is possible to understand if there is a stop in dried plastic material consumption. The protection procedure provides two steps, first lowering the process temperature and then switching the dryer in standby mode until next charge of hopper loader #1 occurs. When starting a new drying, the system waits for the drying time set in the SLS parameters and after this it monitors the charging frequency of hopper loader, if no charging occurs, the system starts the MPM procedure.

If this system is used in combination with the SLS and the “advanced” working mode, the best drying condition is provided for the plastic material.

The parameters that needs to be set are:

t1: is the maximum time from one charge and the other of the hopper loader #1 that during normal production conditions elapse, if that happens there is more time with no charging action it means that the throughput has lowered or stopped and so the dryer starts the first protection action of lowering the process temperature.

Δ temperature: is the delta of temperature to reduce the process temperature after the t1 is elapsed

Time to standby: is the time that has to elapse before the dryer switches to standby mode

2 By return air temperature.

In this system an additional temperature probe T6 is installed near the hopper in the air return pipe. The dryer works with normal operation set parameters until the return air temperature T6 reaches the set and then engages the MPM reducing the air flow to a minimum value and lowering the process temperature by the set value.

The parameters that needs to be set are:

In Operator menu, the Δ air ret which is the set of the difference from process for T6 to start MPM by temperature

In Machine menu, Hysteresis time is a delay before getting back to normal process condition and is meant to avoid high changing frequency; delta temperature reduction is the negative delta in process temperature set when MPM is active.

Typical Applications (Continued)

SLS

The Safety Loading System is a special feature that assures the material to be completely dried before it can be used. The working principle is different depending on the configuration of the dryer:

- Machine hopper loader #2 = present: the SLS blocks the machine hopper loader until the initial drying time is elapsed to avoid wet material to charge.
- Hopper discharge valve = present: the SLS blocks the hopper discharge valve closed until the initial drying time is elapsed to avoid wet material to charge. Instead of the hopper valve the coming out signal from O6 in the electronic board could be used to give a signal to the central loading system.
- Machine hopper loader #2 & hopper discharge valve or line cleaning valve = present the SLS blocks the machine hopper loader and the valve until the initial drying time is elapsed to avoid wet material to charge.

The drying time is set in different ways depending if the dryer is working in manual mode or advanced mode:

- Manual mode: the software require to set the drying time manually
- Advanced mode: the drying time is taken from the internal database

When the SLS is active there is the possibility to reset the feature, just press the “RES” key, *see Control Panel Figure 6 in the Installation Section of the manual*. Insert the dryer password (default 555). This can be useful for example in a temporary electric power outage.

How the MicroWheel MW1 Works

- 1** In the machine there is the rotating wheel made with molecular sieves, with high moisture absorption capacity.
- 2** The wheel goes through a rotating **process cycle** (i.e. drying cycle) and **regeneration cycle** (while one section of the rotor is doing the process cycle, the other one is doing the regeneration cycle).
- 3** In the process cycle, the blower **S2** sends the moist air coming from the hopper to the wheel in the process stage. Here, the air is dehumidified by the molecular sieves and then sent back to the hopper, in order to remove more moisture from the plastic granules before re-entering the cycle.
- 4** The purpose of the regeneration cycle is to remove the moisture from the wheel that has just completed a process cycle (to prepare it for the next cycle). This cycle is in two stages:
 - a) **Heating stage:** in this stage, heated air is sent through the wheel to remove the moisture absorbed by the molecular sieves in the previous process cycle.
 - b) **Cooling stage:** in this stage, cold air is sent through the wheel to bring the molecular sieves to the optimal temperature for the next process stage.
- 5** At the end of the regeneration stage (i.e. when the rotor in the regeneration stage is ready to start another process cycle), the wheel section goes in to processing stage through the rotation.

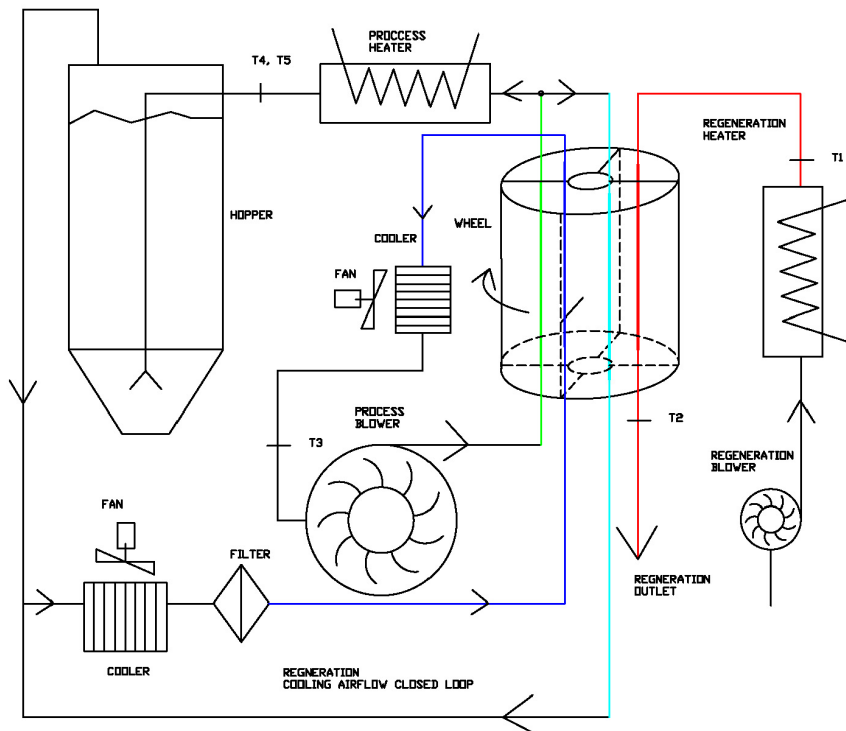
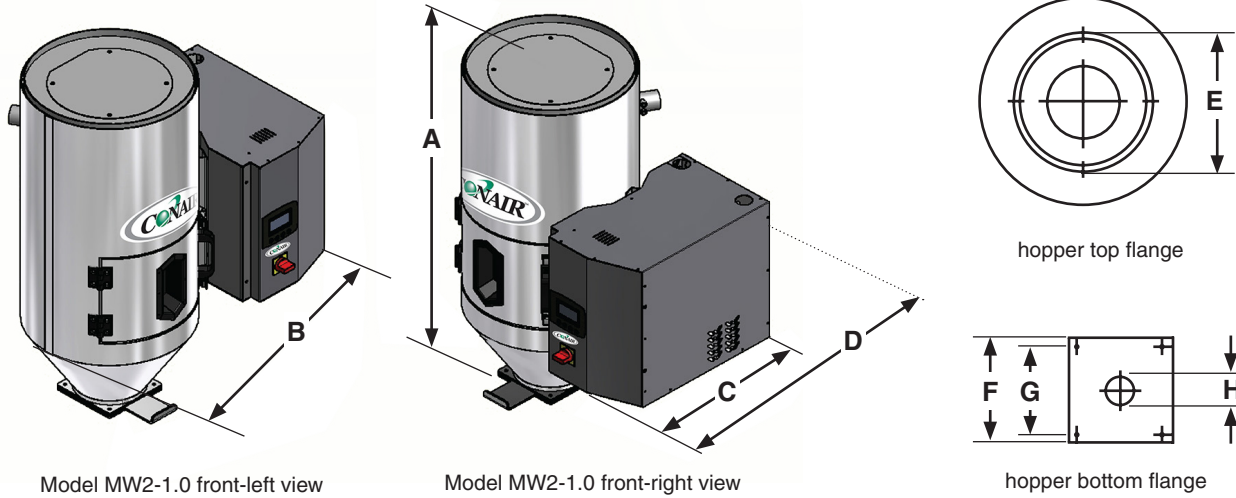

Figure 4

- T1 = regeneration temperature typical range from 149 to 338°F {65 to 170°C}
- T2 = regeneration outlet temperature typical range from 113 to 230°F {45° to 110°C}
- T3 = process blower inlet temperature typical range from 113 to 176°F {45° to 80°C}
- T4 = process temperature typical range from 122 to 356°F {50° to 180°C}
- T5 = process safety temperature typical range from 122 to 356°F {50° to 180°C}
- T6 = return air temperature, antistress system typical range from ambient temperature to 302°F {150°C}

Specifications: MicroWheel MW1 and MW2

MW MODELS MW1 and MW2



Model MW2-1.0 front-left view

Model MW2-1.0 front-right view

hopper top flange

hopper bottom flange

Description
2

Model number	MW1-0.2	MW1-0.5	MW1-1.0	MW2-1.0	MW2-1.75
Performance characteristics (with full hopper)					
Drying temperature* °F {°C}	131 - 356 {55 - 180}	131 - 356 {55 - 180}	131 - 356 {55 - 180}	131 - 320 {55 - 160}	131 - 320 {55 - 160}
Dewpoint† °F {°C}	-40 {-40}	-40 {-40}	-40 {-40}	-40 {-40}	-40 {-40}
Max. airflow‡ ft³/min. {m³/hr}	8.2 {14.0}	8.2 {14.0}	8.2 {14.0}	14.7 {25.0}	14.7 {25.0}
Dimensions					
A - Overall height inches {mm}	19.5 {495}	24.6 {626}	27.7 {704}	27.7 {704}	38.5 {978}
B - Overall width inches {mm}	18.3 {465}	20.6 {524}	25.1 {637}	28.8 {732}	28.8 {732}
C - Depth of dryer inches {mm}	17.7 {450}	17.7 {450}	17.7 {450}	25.8 {655}	25.8 {655}
D - Overall depth (including filter) inches {mm}	20.7 {526}	21.6 {549}	23.9 {607}	26.8 {681}	26.8 {681}
Hopper capacity ft³ {liter}	0.21 {6.0}	0.53 {15.0}	1.06 {30.0}	1.06 {30.0}	1.77 {50.0}
Air hose diameter inches {mm}	1.5 {38}	1.5 {38}	1.5 {38}	1.5 {38}	1.5 {38}
E - Hopper top flange diameter inches {mm}	5.6 {141.5}	11.0 {280}	11.0 {280}	11.0 {280}	11.0 {280}
F - Hopper bottom flange width inches {mm}	7.3 {185}	7.3 {185}	7.3 {185}	7.3 {185}	7.3 {185}
G - Hopper bottom flange mounting pattern inches {mm}	6.1 {155}	6.1 {155}	6.1 {155}	6.1 {155}	6.1 {155}
H - Hopper bottom flange outlet diameter inches {mm}	2.4 {60}	2.4 {60}	2.4 {60}	2.4 {60}	2.4 {60}
Approximate weight					
Standard installed (hopper empty) lb {kg}	77 {35}	82 {37}	106 {48}	133 {60}	144 {65}
Voltage - full load amps					
220/1/50 or 60	4.5	4.5	4.5	9.5	9.5

SPECIFICATION NOTES

- * Drying temperature setpoint is set by the user, depending on the material type and the application.
- † Energy usage and calculations are based on a dewpoint of -40°F (-40°C).
- ‡ Airflow range is calculated by the control, based on application.

Specifications may change without notice. Check with a Conair representative for the most current information.

Throughputs: MicroWheel Models MW1 and MW2

The following chart shows the throughput range for various material types (pre-programmed into the dryer control). This is only a guide, as throughputs will vary based on application.

Material	Bulk Density	Residence Time	Temperature	Dew Point	MW1		MW2	
Recipe code	lb/ft ³ {Kg/dm ³ }	hours	°F {°C}	°F {°C}	lb/hr {kg/hr} minimum	lb/hr {kg/hr} maximum	lb/hr {kg/hr} minimum	lb/hr {kg/hr} maximum
AS mold	37.5 {0.60}	3	176 {80}	-40 {-40}	2.8 {1.3}	12.5 {5.6}	11.0 {5}	21.9 {9.9}
ABS ext	37.5 {0.60}	3.5	185 {85}	-40 {-40}	2.4 {1.1}	10.7 {4.9}	8.8 {4}	18.8 {8.5}
ABS / PC	40.6 {0.65}	3	212 {100}	-40 {-40}	2.6 {1.2}	13.5 {6.1}	11.0 {5}	23.7 {10.8}
ASA	31.2 {0.50}	3	194 {90}	-40 {-40}	2.4 {1.1}	10.4 {4.7}	11.0 {5}	18.2 {8.3}
CA	31.2 {0.50}	2.5	158 {70}	-40 {-40}	2.2 {1.0}	12.5 {5.6}	8.8 {4}	21.8 {9.9}
CAB	31.2 {0.50}	2.5	158 {70}	-40 {-40}	2.0 {0.9}	12.5 {5.6}	8.8 {4}	21.8 {9.9}
CP	37.5 {0.60}	4	167 {75}	-40 {-40}	2.0 {0.9}	9.4 {4.3}	8.8 {4}	16.4 {7.4}
EVA	37.5 {0.60}	3	176 {80}	-40 {-40}	1.8 {0.8}	12.5 {5.6}	6.6 {3}	21.9 {9.9}
EPDM	32.5 {0.52}	4	176 {80}	-40 {-40}	1.8 {0.8}	8.1 {3.7}	6.6 {3}	14.2 {6.4}
LCP	37.5 {0.60}	4	302 {150}	-40 {-40}	2.6 {1.2}	9.4 {4.3}	11.0 {5}	16.4 {7.4}
PA 6	40.6 {0.65}	5	167 {75}	-40 {-40}	2.2 {1.0}	8.1 {3.7}	8.8 {4}	14.2 {6.4}
PA 66	40.6 {0.65}	5	176 {80}	-40 {-40}	2.2 {1.0}	8.1 {3.7}	8.8 {4}	14.2 {6.4}
PA66 + 35FV	53.1 {0.85}	5	176 {80}	-40 {-40}	2.6 {1.2}	10.6 {4.8}	11.0 {5}	18.6 {8.4}
PA 12	40.6 {0.65}	3	167 {75}	-40 {-40}	2.2 {1.0}	13.5 {6.1}	8.8 {4}	23.7 {10.8}
PA 11	40.6 {0.65}	5	167 {75}	-40 {-40}	2.2 {1.0}	8.1 {3.7}	8.8 {4}	14.2 {6.4}
PC	43.7 {0.70}	3	248 {120}	-40 {-40}	2.8 {1.3}	14.6 {6.6}	11.0 {5}	25.5 {11.6}
PC for CD	43.7 {0.70}	4	248 {120}	-40 {-40}	1.8 {0.8}	10.9 {4.9}	6.6 {3}	19.1 {8.7}
PC + PBT	43.7 {0.70}	3.5	230 {110}	-40 {-40}	2.2 {1.0}	12.5 {5.6}	8.8 {4}	21.9 {9.9}
PE	37.5 {0.60}	3	194 {90}	-40 {-40}	2.8 {1.3}	12.5 {5.6}	11.0 {5}	21.9 {9.9}
PE (40% n.f)	37.5 {0.60}	5	185 {85}	-40 {-40}	2.2 {1.0}	7.5 {3.4}	8.8 {4}	13.1 {5.9}
PEEK	37.5 {0.60}	4	311 {155}	-40 {-40}	2.6 {1.2}	9.4 {4.3}	11.0 {5}	16.4 {7.4}
PEI	37.5 {0.60}	4.5	311 {155}	-40 {-40}	2.6 {1.2}	8.3 {3.8}	11.0 {5}	14.6 {6.6}
PEN	53.1 {0.85}	5	338 {170}	-40 {-40}	2.0 {0.9}	10.6 {4.8}	6.6 {3}	18.6 {8.4}
PES	43.7 {0.70}	4	311 {155}	-40 {-40}	2.6 {1.2}	10.9 {4.9}	11.0 {5}	19.1 {8.7}
PES	43.7 {0.70}	4	356 {180}	-40 {-40}	2.2 {1.0}	10.9 {4.9}	8.8 {4}	19.1 {8.7}
PET	53.1 {0.85}	4	266 {130}	-40 {-40}	2.4 {1.1}	13.3 {6.0}	8.8 {4}	23.2 {10.5}
PET ext	53.1 {0.85}	6	338 {170}	-40 {-40}	1.8 {0.8}	8.9 {4.0}	6.6 {3}	15.5 {7.0}
PETG	37.5 {0.60}	4.5	149 {65}	-40 {-40}	2.0 {0.9}	8.3 {3.8}	8.8 {4}	14.6 {6.6}
PBT	43.7 {0.70}	3.5	257 {125}	-40 {-40}	2.6 {1.2}	12.5 {5.6}	11.0 {5}	21.9 {9.9}
PI	37.5 {0.60}	2.5	248 {120}	-40 {-40}	2.6 {1.2}	15.0 {6.8}	11.0 {5}	26.3 {11.9}
PMMA	40.6 {0.65}	4	176 {80}	-40 {-40}	2.4 {1.1}	10.2 {4.6}	8.8 {4}	17.8 {8.1}
POM	37.5 {0.60}	3	212 {100}	-40 {-40}	2.8 {1.3}	12.5 {5.6}	11.0 {5}	21.9 {9.9}
PP	31.2 {0.50}	2.5	194 {90}	-40 {-40}	2.8 {1.3}	12.5 {5.6}	11.0 {5}	21.8 {9.9}
PP ext	31.2 {0.50}	2	212 {100}	-40 {-40}	3.1 {1.4}	15.6 {7.1}	13.2 {6}	27.3 {12.4}
PP GF20	39.3 {0.63}	3	194 {90}	-40 {-40}	2.6 {1.2}	13.1 {5.9}	11.0 {5}	22.9 {10.4}
PP GF30	42.5 {0.68}	3	194 {90}	-40 {-40}	2.6 {1.2}	14.2 {6.4}	11.0 {5}	24.8 {11.2}
PP (40% t.)	37.5 {0.60}	2.5	194 {90}	-40 {-40}	2.2 {1.0}	15.0 {6.8}	8.8 {4}	26.3 {11.9}
PPO	31.2 {0.50}	2.5	221 {105}	-40 {-40}	2.8 {1.3}	12.5 {5.6}	11.0 {5}	21.8 {9.9}
PPS	37.5 {0.60}	3.5	284 {140}	-40 {-40}	2.8 {1.3}	10.7 {4.9}	11.0 {5}	18.8 {8.5}
PS	34.3 {0.55}	2	176 {80}	-40 {-40}	2.8 {1.3}	17.2 {7.8}	11.0 {5}	30.0 {13.6}
PSU	40.6 {0.65}	3.5	275 {135}	-40 {-40}	2.6 {1.2}	11.6 {5.3}	11.0 {5}	20.3 {9.2}
PSU GF20	52.4 {0.84}	3	302 {150}	-40 {-40}	1.8 {0.8}	17.5 {7.9}	6.6 {3}	30.6 {13.9}
PUR	43.7 {0.70}	3	185 {85}	-40 {-40}	2.4 {1.1}	14.6 {6.6}	8.8 {4}	25.5 {11.6}
PVC	49.9 {0.80}	1.5	158 {70}	-40 {-40}	4.0 {1.8}	33.3 {15.1}	15.4 {7}	58.2 {26.4}
SAN	31.2 {0.50}	2.5	176 {80}	-40 {-40}	2.8 {1.3}	12.5 {5.6}	11.0 {5}	21.8 {9.9}
SB	37.5 {0.60}	2	176 {80}	-40 {-40}	2.8 {1.3}	18.8 {8.5}	11.0 {5}	32.8 {14.9}
TPE	40.6 {0.65}	3	230 {110}	-40 {-40}	2.0 {0.9}	13.5 {6.1}	8.8 {4}	23.7 {10.8}
TPU	40.6 {0.65}	3	194 {90}	-40 {-40}	2.4 {1.1}	13.5 {6.1}	8.8 {4}	23.7 {10.8}

Installation

Unpacking the Boxes	3-2
Installing the MicroWheel MW1	3-4
Regeneration Discharge Pipe	3-6
Electrical Connections	3-7
Control Panel	3-7

Unpacking the Boxes

Safety Rules for Handling, Lifting, Packing, and Unpacking

- 1** The machine must be handled by expert personnel in accordance with statutory health and safety regulations.
- 2** Use handling equipment that conforms to the safety requirements stated in directive 89/392/EU and subsequent amendments. The handling equipment be accompanied by documentation certifying its conformity to the above requirements and must be capable of bearing the weight of the machine plus its packing. Carefully follow any instructions marked on the machine packing (the weight is given on the outside of the packing). Do not use ropes or chains to harness the pack.
- 3** All handling operations must be performed with the machine completely empty, i.e. with no process materials or fluids inside it, and with any external support structures removed.
- 4** All the machine parts involved in the lifting operation are sized for handling solely the machine with no accessories installed.
- 5** If the machine is lifted with ropes, make sure its weight is evenly distributed over all the lifting points and that the strain on the ropes is uniform. The angle between each rope and the horizontal plane must not be less than 45°.
- 6** Fasten any loose parts. Make sure that the load is properly balanced and securely fastened to the handling equipment. Always proceed with the utmost caution to avoid injuring persons or damaging the machine.
- 7** All persons not involved in operating the means of transport must be kept at a safe distance from the moving load.
- 8** Position the machine on a perfectly flat surface of a suitable size that is strong enough to bear its weight.
- 9** After removing the packing, check that all parts of the machine are present and in good condition. If you have any doubts, do not use the machine: contact the CONAIR Technical Service Department or an authorized service center. The packaging must be disposed of in accordance with binding waste disposal regulations.

Contact Conair
Parts and Service
Phone: 800-458-1960
From outside of the
United States,
Call: 814 437 6861



CAUTION: Protective Equipment

The packing material can cause cuts or abrasions.

Pay special attention and always wear suitable protective equipment!

Unpacking the Boxes (Continued)

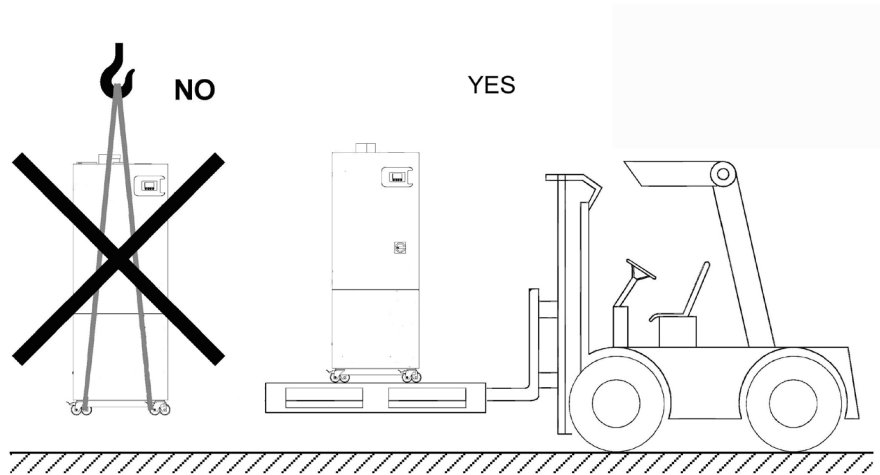

Figure 5

The machine can be shipped and packed in cardboard packing that can be palletized, crates, cages, wooden pallets and protective plastic sheets. Keep the packing materials to protect the machine if it has to be moved again in the future. If the material is disposed of, observe the waste disposal regulations in force in the place of installation.



Warning:

- Risk of machine falling during handling procedures.
- Pay special attention and always wear suitable personal protective equipment!
- Do not stand near the machine when in movement.
- Do not use slings to lift the machine: only move the unit with a fork-lift truck or pallet truck.
- Before moving the machine, lift it slowly a few inches {centimeters} with the fork-lift truck or pallet truck in order to find the center of gravity.

Environment

Use the dryer under the following environmental conditions: otherwise, the dryer may be damaged.

Surrounding air temperature	32°F to 122°F {0°C to +50°C} (non-freezing)
Ambient humidity	90%RH maximum (non-condensing)
Storage temperature	32°F to 122°F {0°C to +50°C} (non-freezing)
Atmosphere	Indoors (free from corrosive gas, flammable gas, oil mist, dust and dirty)
Altitude	Maximum 3280.83ft. {1000m} above the sea level for standard operation. After that derate by 3% every 1640 to 8202 ft.{500 up to 2500m} (91%).
Vibration	5.9 m/s ²

Unpacking the Boxes (Continued)

Power Supply

For AC power, follow the instructions in the table below:

Voltage	380V (424V in UK), steady-state voltage: 0.9 to 1.1 times the rated voltage
Frequency	50Hz, the tolerance range goes from 0.99 to 1.01 times the nominal frequency in a continuous manner; 0.98 to 1.02 times for a short period.
Harmonics	The harmonic distortion due to the sum of the harmonics from the second to the fifth that does not exceed 10% of the rms value of the total voltage between the active conductors. Further distortion is allowed, for the sum of the harmonics from the sixth to the thirtieth, equal to 2% of the total rms voltage between the conductors.
Voltage unbalance	Neither the negative sequence component, nor the component of zero sequence voltage phase supply must be greater than 2% of the direct sequence component of the voltage.
Voltage interruption	Voltage power supply is interrupted or reduced to zero for a time not longer than 3 ms, at any instant of the power cycle with more than 1 s between two successive breaks.
Voltage dips	Voltage dips do not exceed 20% of the peak voltage supply for more than one cycle with more than 1 s between two successive dips.

Installing the MicroWheel MW1

Installation Safety Rules

- 1** The machine must be installed by skilled personnel in compliance with binding safety and health regulations, following the instructions in this manual.
- 2** Make sure the installation work is performed in conditions of adequate visibility that remain constant through time; install supplementary lighting if necessary.
- 3** Mark off the work zone with tape and put up notices warning of the hazards in the areas where the installation work is taking place.
- 4** Install the machine in a place that is protected from aggressive chemicals and the weather.
- 5** Check that the supply voltage and frequency stated on the dryer settings plate correspond to those of the electricity mains and check that the mains circuit is suitably scaled for the machine maximum power input (*refer to the “technical data” table and the wiring diagrams in the Troubleshooting section of this manual*).
- 6** The machine must be connected to an efficient ground connection (as specified in binding electrical safety regulations). You must make sure that you comply with this essential safety requirement. If you have any doubts, have the circuit thoroughly checked by a qualified electrician. Electrical safety devices, suitably scaled for the total machine power, must be installed at the point of connection to the electrical power feeding line (*see wiring diagrams in the Troubleshooting section of this manual*).

Installing the MicroWheel MW1 (Continued)

⚠ WARNING: Risk of serious damage to health, injury or death.

It is strictly forbidden to remove or modify the devices and guards fitted by the manufacturer.

Positioning the MicroWheel MW1

- 1** Position the machine on a perfectly flat surface, making sure it is suitably constructed and sized in relation to the weight and dimensions of the machine and the connected structures.
- 2** Observe the minimum positioning clearances > 31.5 in. {800 mm} all around the unit. Failure to observe these clearances could impede installation work or prevent access to the machine for maintenance purposes.
- 3** The chosen installation site must offer sufficient ventilation for the machine and must not be subject to the presence of hazardous processes or possible concentrations of explosive.

Hoses connection

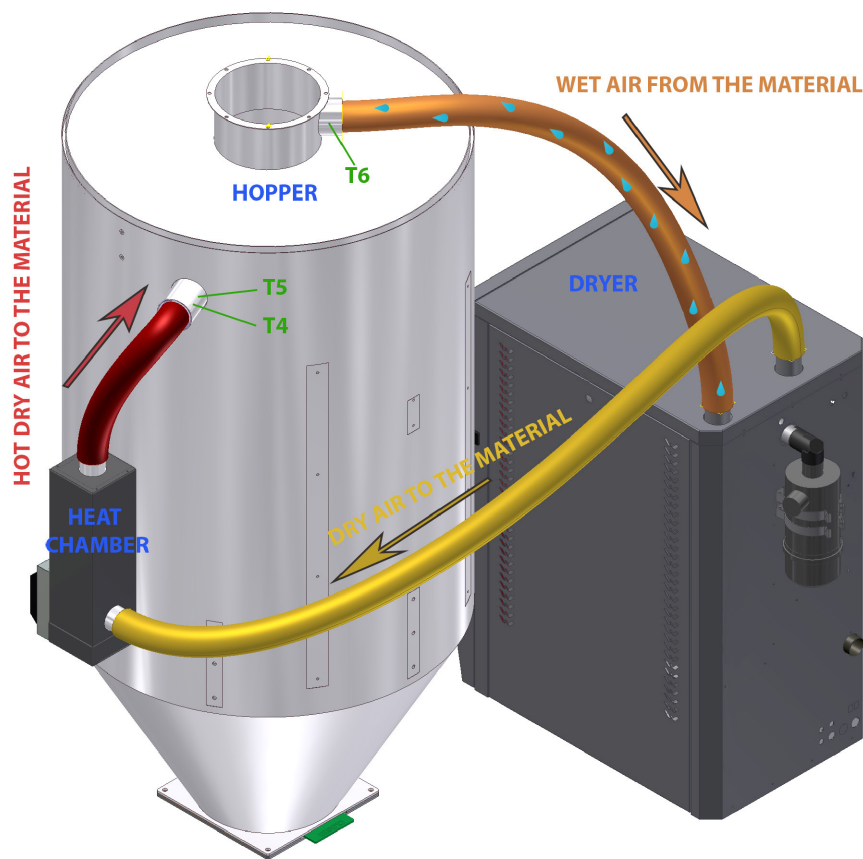

Figure 6

Regeneration Discharge Pipe

The regeneration outlet 4 (*see Figure 7*) is installed on the back of the dryer. If you want to make a special pipe to carry them outside the building, fasten a piping to the outlet 4 with metal clamps.

MICROWHEEL (MW1 & MW2) regeneration outlet diameter = 1.4 in. {38mm}.



WARNING: Burning Hazard

Pay special attention and always wear suitable personal protective equipment! Make sure the regeneration discharge steam cannot cause injury to persons or damage equipment.



CAUTION: Risk of Serious Damage to Health, Injury or Death.

Risk of damaging the machine in case of non-evacuation of the regeneration discharge steam. Use pipes resistant to working temperatures above 392°F {200°C}. Execute the piping with a slope to prevent condensate or liquids stagnating. Make sure the regeneration discharge steam is correctly evacuated and to a suitable place



ATTENTION:

When carrying out the following operations, take care not to let nuts and bolts (or other items) get inside the pipes.

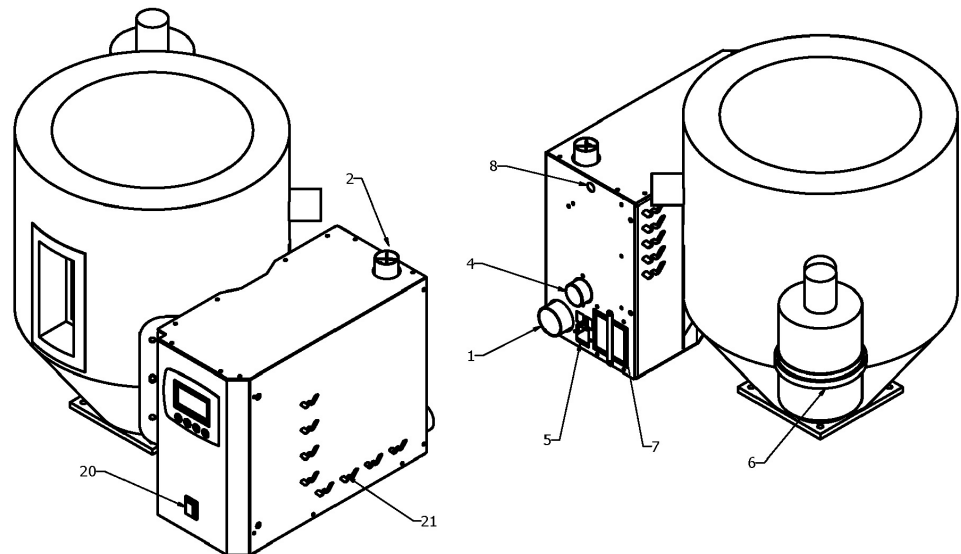

Figure 7

Electrical Connections

⚠ WARNING: Electrical Shock Hazard

To supply the machine, use an electric cable of suitable cross-section for the total power of the machine.

⚠ ATTENTION:

Suitable protection for the total power of the machine must be installed at the point of connection to the electric mains. The use of protection fuses is recommended: follow the instructions given in the attached wiring diagram. In addition, install a main circuit breaker switch between the electricity line and the machine power supply lead; it must be installed in an easily accessible position.

To insert the power cable, use the entry 5 (see Figure 7).
The connection between the machine and the main power panel must be done following the indications given on the wiring diagram.

Control Panel

The unit is equipped with a blue LCD graphic display and in the bottom part there are disposed four keys to control the dryer.

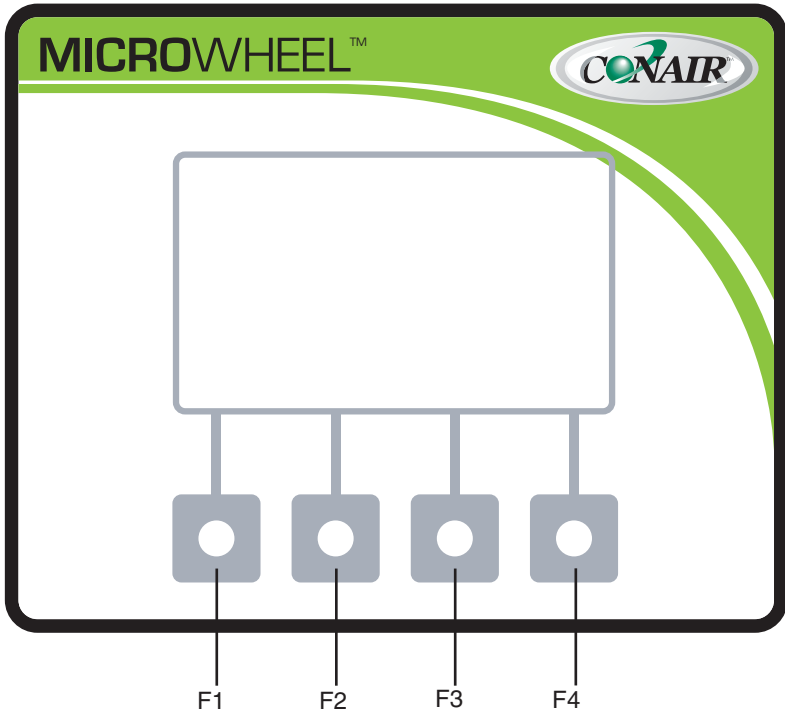

Figure 8

Operation

Routine Start Up	4-2
Stopping the Machine.....	4-3
Menu Entry	4-3
How to Select Manual or Advance.....	4-4
Operator Menu in MANUAL MODE.....	4-4
Operator menu in ADVANCE MODE	4-6
Machine Configuration Setup	4-7
Dryer Settings Setup	4-7
Integrated Pneumatic Convey System Setup (Optional)	4-9
Real Data	4-14
Recipe Set up	4-16

Routine Start Up

When the machine is switched on from the main switch on the front of the door, the panel displays the software version. The logo appears and after a few seconds the boot is complete and the pages are as follows.

(The numerical values displayed are guidelines only.)

This row appears only if weekly timer option is installed.

This is the main page after you switch the unit ON from the main switch when the machine is in MANUAL MODE.

```
w e d 1 3 - 0 1 - 2 0 1 0
T O U T 3 0 ° C
R E A D Y T O S T A R T
P R . F L O W : 3 6 0 m 3 / h
D E W P N T : - 6 0 ° C
O N P A G S E T
```

Now you can press ON (F1) and the unit starts the warming up cycle. This means that the unit starts warming up the wheel until it reaches the right temperature. After less than five minutes the wheel and the processing blower will start to work. This procedure is needed to assure the correct dew point level even from the start.

This page appears when the unit is warming up. When the regeneration reaches the right temperature the unit will display RUNNING.

```
T O U T 3 0 ° C
W A R M I N G U P
P R . F L O W : 3 6 0 m 3 / h
D E W P N T : - 6 0 ° C
O N P A G S E T
```

Routine Start Up (Continued)

Stopping the Machine



WARNING:

To stop the machine in an emergency, turn the main switch 20 (See Figure 7). Use this procedure only when strictly necessary and not as a routine operation.

Wait until the machine has cooled down to room temperature before working on internal parts.

To stop the machine proceed as follows:

- 1 Press the OFF key (F1): the machine will not stop immediately, the cooling stage will commence. In this stage the regeneration blower S1 sends air at ambient temperature into the regeneration chamber and the wheel to eliminate the heat. The machine stops after the cooling temperature is reached.
- 2 Turn the main switch and cut off power to the machine.

Menu Entry

From the main menu key press SET

The unit has three menus available:

-WORKING DATA contains all the common settings to work.

-MACHINE DATA contains the basic settings of the configuration of the dryer.

-REAL DATA contains all the temperatures, life of dryer, and power used.

Once you have selected the right menu through the ↑↑ (F2) and ↓↓ (F3) keys confirm with the NEXT (F1) key. Press ESC to step back.

Once you have selected the right ROW press NEXT.

```
W O R K I N G   D A T A
M A C H I N E   D A T A
R E A L       D A T A
N E X T   ↑ ↑       ↓ ↓       E S C
```

Routine Start Up (Continued)

How to Select Manual or Advance

The unit has two modes of use MANUAL or ADVANCE.

Enter the MACHINE DATA menu and the first page is: Machine Set up page (*see Machine Configuration Setup in this section of the manual*).

Press NEXT until you select MANUAL or ADVANCE.

Using the ↑↑ (F2) and ↓↓ (F3) to switch between manual and advance.

Confirm with NEXT then pres ESC until you go back to the main menu.

Select using the UP and DN switch if you want
ADVANCE or MANUAL use.

```
M A C H I N E   S E T - U P

L A N G U A G E :
                E N G L I S H

W O R K I N G   S E T U P :
                M A N U A L

N E X T   ↑ ↑           ↓ ↓           E S C
```

Operator Menu in MANUAL MODE

From the main menu go to the “Working Data”.

Process temperature SET.

Dew point SET

Delta dew point warning (will appear only if the
OPTIONAL dew point probe is installed and activated).

Air flow requested
will appear only if the OPTIONAL MPM is installed
see MPM in the Description Section of this manual.

```
W O R K . P A R A M E T E R S

T . P R O C E S S : 6 2 °

D E W P . S E T : - 1 0 °

Δ D E W W A R N : 2 5 °

P R . F L O W : 5 8 0 m 3 / H

Δ A I R R E T : 2 0 °

N E X T   ↑ ↑           ↓ ↓           E S C
```

- NEXT to move to the next setting
- ↑↑ to change to the higher value
- ↓↓ (F3) to change to the lower value
- ESC to move to the previous setting

Routine Start Up (Continued)

Hopper Loader Configuration (Hopper Loader #1 is Optional)

If hopper loader #1 is installed and activated the next page will appear with the working setting to be adjusted or accepted. The vacuum blower power can be adjusted to required level to avoid dust formation due to the excessive convey speed for the hopper loader #1.

<p>Switch the loader ON or OFF.</p> <p>This parameter represents the suction time of the receiver.</p> <p>This parameter represents the power of the vacuum blower required for this receiver.</p> <p>This row will appear only if the proportional valve is installed on this loader.</p> <p>This represents the numbers of proportional cycles inside the suction time, this increases the homogenizing .</p> <p>Percentage of regrind.</p>	<table style="width: 100%; border-collapse: collapse;"> <tr> <td style="width: 70%;">H O P P . L O A D E R # 1</td> <td style="width: 5%;"></td> <td style="width: 25%;"></td> </tr> <tr> <td>L O A D E R :</td> <td></td> <td>O F F</td> </tr> <tr> <td>L O A D T I M E :</td> <td></td> <td>2 0 s</td> </tr> <tr> <td>S U C K P O W :</td> <td></td> <td>9 0 %</td> </tr> <tr> <td># P R O P . C Y C L E :</td> <td></td> <td>2</td> </tr> <tr> <td>R E G R I N D % :</td> <td></td> <td>2 5 %</td> </tr> <tr> <td>N E X T ↑ ↑ ↓ ↓</td> <td></td> <td>E S C</td> </tr> </table>	H O P P . L O A D E R # 1			L O A D E R :		O F F	L O A D T I M E :		2 0 s	S U C K P O W :		9 0 %	# P R O P . C Y C L E :		2	R E G R I N D % :		2 5 %	N E X T ↑ ↑ ↓ ↓		E S C
H O P P . L O A D E R # 1																						
L O A D E R :		O F F																				
L O A D T I M E :		2 0 s																				
S U C K P O W :		9 0 %																				
# P R O P . C Y C L E :		2																				
R E G R I N D % :		2 5 %																				
N E X T ↑ ↑ ↓ ↓		E S C																				

(Hopper Loader #2 will be Optional in future models)

If hopper loader #2 is installed and activated the next page will appear with the working setting to be adjusted or accepted. The vacuum blower power can be adjusted to required level to avoid dust formation due to the excessive convey speed for the hopper loader #2. The cleaning time appears only if the cleaning valve is installed in the machine. [See Line Cleaning Valve in the Description Section of this manual.](#)

<p>Switch the loader ON or OFF.</p> <p>This parameter represents the suction time of the receiver.</p> <p>This parameter represents the power of the vacuum blower required for this receiver.</p> <p>Purge time of the suction pipe</p> <p>This row will appear only if the proportional valve is installed on this loader.</p> <p>This represents the number of proportional cycles inside the suction time, increasing the homogenizing .</p>	<table style="width: 100%; border-collapse: collapse;"> <tr> <td style="width: 70%;">H O P P . L O A D E R # 2</td> <td style="width: 5%;"></td> <td style="width: 25%;"></td> </tr> <tr> <td>L O A D E R :</td> <td></td> <td>O F F</td> </tr> <tr> <td>L O A D T I M E :</td> <td></td> <td>3 0 s</td> </tr> <tr> <td>S U C K P O W :</td> <td></td> <td>9 0 %</td> </tr> <tr> <td>P U R G E T I M E :</td> <td></td> <td>1 0 s</td> </tr> <tr> <td># P R O P . C Y C L E :</td> <td></td> <td>2</td> </tr> <tr> <td>R E G R I N D % :</td> <td></td> <td>2 5 %</td> </tr> <tr> <td>N E X T ↑ ↑ ↓ ↓</td> <td></td> <td>E S C</td> </tr> </table>	H O P P . L O A D E R # 2			L O A D E R :		O F F	L O A D T I M E :		3 0 s	S U C K P O W :		9 0 %	P U R G E T I M E :		1 0 s	# P R O P . C Y C L E :		2	R E G R I N D % :		2 5 %	N E X T ↑ ↑ ↓ ↓		E S C
H O P P . L O A D E R # 2																									
L O A D E R :		O F F																							
L O A D T I M E :		3 0 s																							
S U C K P O W :		9 0 %																							
P U R G E T I M E :		1 0 s																							
# P R O P . C Y C L E :		2																							
R E G R I N D % :		2 5 %																							
N E X T ↑ ↑ ↓ ↓		E S C																							

To return in the main page press NEXT or ESC until the main page appears. In this mode the operator can set manually the Drying parameters for the most flexible usage of the unit.

Routine Start Up (Continued)

Operator menu in ADVANCE MODE

From the main menu go to the “Working Data” menu. *See Menu Entry in the Operation Section of the manual.*

Recipe number selected	R E C I P E S
recipe name	N . M A T E R I A L 1 3
Delta dew point warning	A B S m o l d .
Material consumption	Δ D E W W A R N : 2 5 °
	T H R U - P U T : 2 2 k g / h
	N E X T ↑ ↑ ↓ ↓ E S C

If hopper loaders are installed and software activated the configuration pages will appear in the same way of “hopper loader configuration” and alarm data logger.

In the ADVANCE MODE the operator needs to select only the material used through the internal recipe database and the material consumption, if a throughput selected is higher than what the dryer can give, the system will give you a warning and automatically set the highest throughput.

To return in the main page press NEXT or ESC until the main page appears.

Machine Configuration Setup

When you are in the Machine SETUP you can leave this menu by pressing ESC or NEXT switch until you go back to the main page.

Move forward by pressing NEXT

Move back by pressing ESC

Change by pressing ↑↑ (F2) and ↓↓ (F3)

Machine Data Setup

You can select the language.

Here it's possible to select the machine mode advance or manual.

```
M A C H I N E   S E T - U P
L A N G U A G E :
                E N G L I S H
O P E R A T I O N
                M A N U A L
N E X T   ↑ ↑           ↓ ↓           E S C
```

Here you can select if you want to see or modify a material recipe with this page only if you are in ADVANCE mode.

To modify a recipe see Recipe Set Up

```
M A T E R I A L S   P A R A M .
M O D I F Y :   N O
N E X T   ↑ ↑           ↓ ↓           E S C
```

(Continued)

Machine Configuration Setup (Continued)

The following page applies only if the weekly timer has been installed (OPTION).

In this page you set the time and date.
Use the UP and DN switch to change the value and
NEXT or ESC to move forward or back.

This represents the date set.
This represents the time set.

```

      W A T C H   S E T U P
h o u r :      1 2 m i N :      2 7
d a y :        1 5 m o N :      1 1
w e e k : T H U
y e a r :      7
T H U   1 5 - 1 1 - 2 0 0 7
1 2 : 2 7 : 0 2 s
N E X T   ↑ ↑           ↓ ↓           E S C
    
```

Here you can choose if you want to enable the auto
power on and off.
This OPTION can be used to start the dryer before the
start of the shift.

```

      S E L F   P O W E R   O N
E N A B L E : Y E S
    
```

If you have enabled the timer start on, the following pages show the day of the week and
the time when you want the machine start and stop.

Move through the menu with NEXT and ESC use the
UP and DN key do change the time.

```

      M O N D A Y
                O N   :      1 0 : 0 0
                O F F :      2 0 : 0 0
      T U E S D A Y
                O N   :      1 0 : 0 0
                O F F :      2 0 : 0 0
N E X T   ↑ ↑           ↓ ↓           E S C
    
```

Machine Configuration Setup (Continued)

Integrated Pneumatic Convey System Setup (Optional)

If integrated vacuum convey blower is installed, the next page will display the warning for EV2. The value is the minutes that will elapse before the unit will show the warning code 36 to clean the vacuum convey filter (10 at). The minutes are intended as minutes elapsed while the vacuum blower is running.

Move through the menu with NEXT and ESC use the UP and DN key do change the value displayed

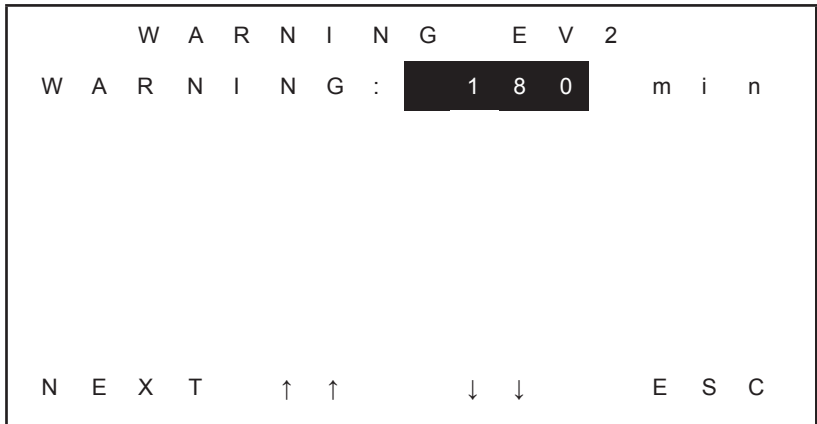

Move through the menu with NEXT and ESC use the UP and DN key to change the value displayed

Δ T infer: Is the maximum lower deviation for process temperature that can be accepted (used to warn if the process heating system does not work)

Time rise: delay between problem detection and the process warming shutdown.

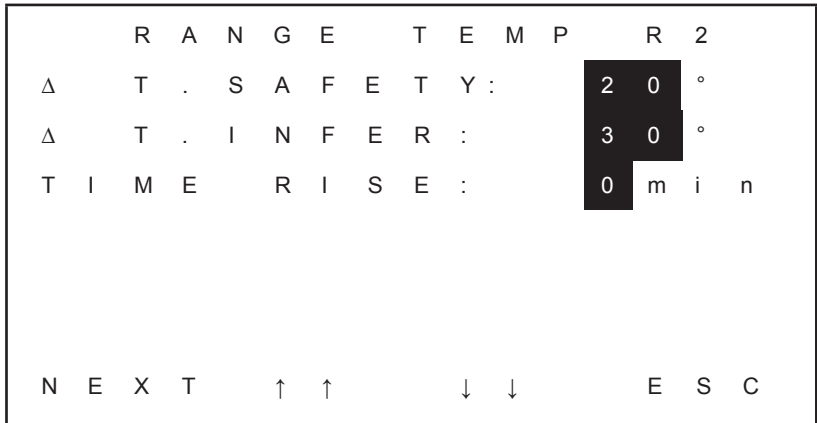

MPM

The Material Protection Management is a feature available if there is the drying hopper feeder (loader 1) installed in the dryer. [See Description Section entitled, MPM for the complete description of the feature.](#)

In this page there is the possibility to enable the material protection management. Select "NOT IN USE" to disengage the feature or:

- LOADER #1 to activate MPM by means of hopper loader n°1 flap sensor signal or IMM shot signal.
- RETURN AIR T to activate by means of a temperature probe sensor on the return air of the hopper (OPTIONAL) If this feature is activated by means of temperature, a delta temperature from the process one has to be set to activate the MPM. Normally from 20 to 60 °C of delta.

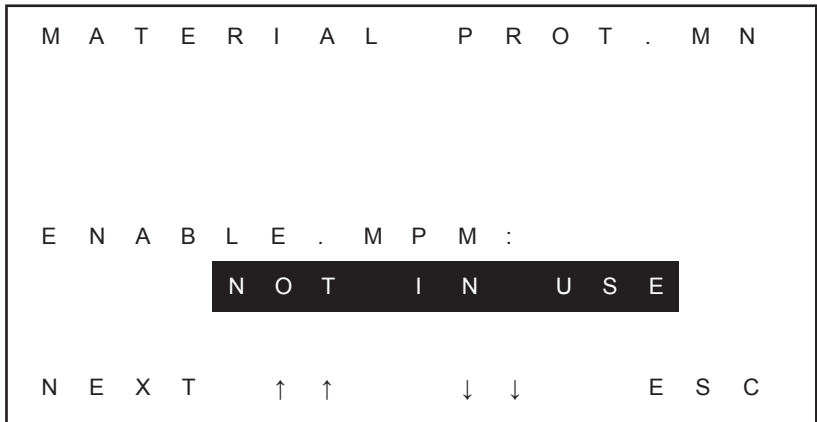

Machine Configuration Setup (Continued)

Next page will appear only if “RETURN AIR” has been selected in the Material Protection Management enabling page.

This is a minimum time to wait before resuming normal process temperature and airflow even if return air temperature is lower than setpoint.

Delta process temperature that will be lowered after the time t1.

```

M P M   P A R A M E T E R S
H Y S T E R E S I S   t i m e
t . h y s t   :   3 0   m i n
Δ   t e m p e r a t u r e
r e d u c t i o n :   2 0 ° C

N E X T   ↑ ↑   ↓ ↓   E S C
    
```

Next page will appear only if “LOADER #1” has been selected in the Material Protection Management enabling page.

This is the elapse time before lowering the process temperature since no charging action occurs on hopper loader 1.

Delta process temperature that will be lowered after the time t1.

Elapse time after t1, before the dryer start the standby mode if still no charging action occurs on hopper loader 1.

```

M P M   P A R A M E T E R S
T i m e   t o   r e d u c e
t e m p . t 1 :   3 0   m i n
Δ   t e m p e r a t u r e
r e d u c t i o n :   2 0 ° C
T i m e   t o   s t a n d b y
p r o c . f l o w :   1 2 0   m i n
N E X T   ↑ ↑   ↓ ↓   E S C
    
```

SLS Safety Loading System is a feature available only if the Hopper loader 1, Hopper loader 2, or a bottom discharge valve on the hopper is installed. It works enabling the suction on hopper loader (2) on the machine or opening the discharge hopper valve only after the drying time. The page with the parameters only appears if one of the components is installed. *See Description Section entitled, SLS for the complete description of the feature.* Every time a material is changed the dryer must be switched off by the main switch to start from zero drying time.

Machine Configuration Setup (Continued)

Activation line for the SLS
 Appear only if present hopper valve (OPTIONAL)
 Default: 99 .

When working in "manual" mode the drying time has to be settled in, if working in "advanced" mode the drying time used is the one in the database.

If the dryer is in standby mode for more than reset time the next start will be considered a new drying phase and the drying time starts again.

```

S A F E T Y   L O A D I N G
      S Y S T E M   S L S
E n a b l e           NO
H o p p e r   l o a d e r   # 1
      m a x : XX   c y c l e / h
D r y i n g   t .           2 4 0 m i n
D e a d   t .           2 4 0 m i n
N E X T   ↑ ↑           ↓ ↓   E S C
  
```

When the SLS finishes the reverse counter and opens the "hopper valve" the system checks the number of loading cycles of hopper loader #1 and if the number is bigger than the value set for the hour the hopper valve is closed and warning "over throughput" is displayed.

If the vacuum filter automatic cleaning feature (optional) is installed in the unit, the following screen appears instead of the "WARNING EV2". The cleaning of the filter will be by means of a compress air stream managed by an electro valve that will blow the dust attached to the filtering web down to the tank. The "pause" value is the time from one cleaning phase and another one and are intended as minutes of real working of the vacuum blower.

Pause from one cleaning and another
 Number of the cleaning shot for the cleaning

Time of switching ON the compressed air valve

Time of switching OFF the valve to allow the
 compressed air tank filled

```

F I L T E R   C L E A N I N G
P A U S E :           9 0   m i n
P U L S E   N U M :           2
t . O N :           2   s
t . O F F :           5   s

N E X T   ↑ ↑           ↓ ↓   E S C
  
```

Machine Configuration Setup (Continued)

If you have installed the hopper loader you will see the hopper loader setup page with the hopper loader parameters, the hopper loader #1 is the hopper loader on the transforming machine, the hopper loader #2 is the hopper loader on the processing hopper.

In this page you set the receiver parameters on the IMM

This parameters representing the waiting time during the material discharge.

This parameters representing the suction time of the receiver.

This is the waiting time between the discharging of the material and the new cycle.

Numbers of suctions cycle before declare the missing material alarm, if set 0 the unit doesn't stop on the alarm.

This represents the numbers of proportional cycles inside the suction time, increasing the homogenizing percentage of regrind.

```

H O P P E R   L O A D E R   #   1
D I S C H A R G E   t   :           3   S
L O A D   T I M E   :           2   0   S
P A U S E   t   :           2   0   S
#   T R Y   :                   3

N E X T   ↑   ↑           ↓   ↓           E S C
    
```

In this page you set the receiver parameters on the hopper.

This parameter represents the waiting time during the material discharge.

This parameters representing the suction time of the receiver.

This is the waiting time between the discharging of the material and the new cycle.

Numbers of suctions cycle before declare the missing material alarm, if set 0 the unit doesn't stop on the alarm

```

H O P P .   L O A D E R   #   2
D I S C H A R G E   t   :           3   S
L O A D   T I M E   :           2   0   S
P A U S E   t   :           2   0   S
#   T R Y   :                   3
#   P R O P .   C Y C L E   :       3
R E G R I N D   %   :           3   0   %

N E X T   ↑   ↑           ↓   ↓           E S C
    
```

In this page you check the total energy used.

Select "YES" if you want reset the energy counter.

```

E N E R G Y   C O U N T E R

T o t a l   :

                2   3   ,   9   k   W   /   H

R E S E T   :   N   O

N E X T   ↑   ↑           ↓   ↓           E S C
    
```

Machine Configuration Setup (Continued)

Here you have to set the hopper size connected to the dryer .

Here you set the effective working hours of the dryer before a message to clean the filter appears.

```

H O P P E R       C A P A C I T Y
M A X :           3 0 0 0       L

P R O C E S S     F I L T E R
C L E A N I N G :   3 9 4       H

N E X T   ↑ ↑           ↓ ↓       E S C
    
```

In this page you can set the two passwords to move to the next one. Press the NEXT switch Machine set up password.

Operator set up password

IF PASSWORD IS 555 NO PASSWORD IS
REQUIRED TO ENTER THE MENU.

```

D R Y E R         P A S S W O R D
I N S E R T :     5 5 5

S E T T I N G S   P A S S W O R D
I N S E R T :     5 5 5

N E X T   ↑ ↑           ↓ ↓       E S C
    
```

Next page is the registry of alarms. There are 30 positions in FIFO mode that show the error code and how much time has elapsed. Time is in minutes and seconds.

Four minutes and 50 seconds ago alarm Te R1 occurred.

```

E R R .   L O G   0 0 0 0 : 0 0
0 1 _ T e   R 1   0 0 0 4 : 5 0
0 2 _ _ _ _ _ _ _ _ _ _ _ _
0 3 _ _ _ _ _ _ _ _ _ _ _ _
0 4 _ _ _ _ _ _ _ _ _ _ _ _
0 5 _ _ _ _ _ _ _ _ _ _ _ _
0 6 _ _ _ _ _ _ _ _ _ _ _ _
N E X T   ↑ ↑           ↓ ↓       E S C
    
```

Machine Configuration Setup (Continued)

Next page gives the chance to erase the error logger file.

Select "YES" if you want to erase the error logger.

```

E R R .   L O G   0 0 0 0 : 0 0
R E S E T :   N O
N E X T   ↑ ↑           ↓ ↓           E S C
    
```

Real Data

From the main menu go to the "real data" menu. *See Menu Entry in this section.* The first page shows all the power used for the component of the dryer, the percentage of usage and the power actually used. The last row is the total. Rotor dryer has the advantage that the consumption is continuous and does not change during the time for cycles. The power is not measured by means of sensors but is only calculating based on stored data about the elements of the dryers. The actual power can vary especially in case of voltage deviation from standard.

R1 Regeneration heater power
 R2 process heater power
 S1 Regeneration blower power
 S2 Process heater power
 S3 Vacuum blower power
 Total power used by the dryer

```

P O W E R   C O N S U M P
R 1 :       2 0 %           2 8 0 0 W
R 2 :       5 0 %           1 1 0 0 0 W
S 1 :       7 4 %           2 0 0 0 W
S 2 :       6 8 %           4 0 8 0 W
S 3 :                               0 W
T o t a l :                               1 7 9 8 0 W
    
```

Machine Configuration Setup (Continued)

Next page show all the counters.

Life of the dryer, this is the total time elapsed with the dryer running.
 This is the time elapsed from the last cleaning/change of process filter.
 This is how many time the dryer has been switched off without allowing the cooling.
 Rotor identification type

T I M E

d r y e r : 0 0 0 0 9 0 h
f i l t : 0 0 0 0 9 0 h
w r o n g s t o p : 0 0 0 3
R o t . s e r # : A 3 1 2 7 P

Next page show all the live data of the dryer.

Working parameters page
 T1 Regeneration temperature inlet
 T2 Regeneration temperature outlet
 T3 Processing blower temperature inlet
 T4 Processing temperature
 T5 Processing safty temperature
 T6 return air temperature (optional)

IN4 process blower speed rpm/10
 IN5 vacuum blower speed rpm/10*

*only if installed & brushless type

O F F

s t p

T 3 : 1 2 9 °
T 4 : 1 2 9 °
T 5 : 1 2 9 °
T 1 : 1 2 9 ° **T 6 :** 1 2 9 °
T 2 : 1 2 9 ° **I G :** - 4 9 °

i n 4 : 3 5 6 **i n 5 :** 1 2 3

Machine Configuration Setup (Continued)

Recipe Set up

Go to inside the “MACHINE DATA” and first page is the Machine Setup; press next until you reach the page MATERIALS PARAM. Select YES then press NEXT, the following screen will appear:

Here you have to set the hopper size connected to the dryer.

Here you set the effective working hours of the dryer before a message to clean the filter appears.

```

S E L E C T   M A T E R I A L
N .   M A T E R I A L   1 5
N A M E :           A B S / P C

N E X T   ↑ ↑           ↓ ↓           E S C
    
```

The machine recipe database is divided in two areas: From the number 1st to the number 30th are free locations which mean you can store or customize 30 recipes. From the 31st to the 79th are already memorized all the main plastic resin with the drying parameters suggested by the resin producer. These 49 recipes can not be changed but eventually can be copied in one of the 30 free location and modified.

Material name
 Process drying temperature
 K air is to calculate the air flow m3/kg, it represent the volume of air needed to dry 1 kg of plastic; normal values range from 1,2 to 3.
 The resident time to calculate the hopper size.
 Bulk density of the material kg/liter, if unknown can be estimated by multiply solid density x 0.6.
 Dew point recommended for the material.

```

M A T E R I A L   P A R A M .
N A M E :           A B S   m o i d .
T E M P .   D R Y :           8 0 ° C
K .   A I R :           1 . 6
R E S I D . T I M E           3 . 0 h
B .   D E N . :           0 . 6 0
D E W   P N T :           -   4 0 ° C
N E X T   ↑ ↑           ↓ ↓           E S C
    
```

Machine Configuration Setup (Continued)

When you are on the selected recipe page keep pressing NEXT until the end of the page.

Select YES to copy the selected recipe in a new location.

```
S A V E   M A T E R . D A T A
S A V E   ? :   YES
N E X T   ↑ ↑           ↓ ↓           E S C
```

To copy the recipe select which recipe number you want.

```
S E L   N E W   M A T .   N U M
N .   M A T E R I A L   7
N A M E : P R D 7   P R O V A
N E X T   ↑ ↑           ↓ ↓           E S C
```

Once you have copied the recipe in the new memory location you are able to change or customize it.



IMPORTANT:

Be aware that, standard recipes stored in the database are for reference only. The user has to write his own recipes according to a specific material datasheet to assure correct drying. Due to the enormous number of polymers and blends it is not possible to have a universal recipe, so specific recipes have to be set up. Existing database has to be intended as a “starting point” for general materials and not valid in all cases.

Maintenance

Safety Rules for Adjustment, Servicing and Troubleshooting Procedures	5-2
Particular Checks In Case of Molding Problems	5-3
Cleaning the Cooling Elements	5-5

Safety Rules for Adjustment, Servicing and Troubleshooting Procedures

- 1** All adjustment, maintenance and troubleshooting work must be performed by specialized personnel. Specialized personnel are construed as persons who, because of their education, experience, training, and specific knowledge of accident prevention regulations and first aid, have been authorized to carry out checking and preventive maintenance work. These personnel must be provided with all the tools and equipment specified in both local and international accident prevention regulations.
- 2** Thorough inspections, performed at regular intervals, are required to prevent breakdowns and guarantee that the machine works at maximum efficiency through the course of time.
- 3** Unless expressly stated otherwise, all maintenance and adjustment work on the machine, or parts of it must be performed with the machine completely isolated from the electricity, compressed air and water supply sources.
- 4** Cordon off the work zone with tape and put up notices warning of the hazards in the areas where the adjustment, maintenance or troubleshooting work is taking place.
- 5** Wait until the machine and the parts that must be approached have cooled down to ambient temperature before performing any maintenance tasks. Drain off and remove any liquids inside the machine to prevent them from coming into contact with live electrical parts during the maintenance work.
- 6** To avoid injuring persons or damaging objects, make sure that no solids, liquids or gases are discharged or disposed of in the environment. Have these substances removed in suitable containers, in accordance with the binding waste disposal regulations in the place of installation.
- 7** If any breakdowns occur that the operator is unable to remedy, switch off the machine and contact the CONAIR Technical Service Department or an authorized service centre.
- 8** On completing the maintenance work, switch on the machine and perform the operational checks, taking all the necessary precautions. The above-indicated precautions must not be waived until the maintenance work is fully completed.
- 9** Take special care to ensure that the maintenance work does not involve other nearby machines which could represent a potential source of danger. Scheduled maintenance must be performed on a regular basis to guarantee the maximum efficiency of the machine.

Contact Conair
Parts and Service
Phone: 800-458-1960
From outside of the
United States,
Call: 814 437 6861

Particular Checks In Case of Molding Problems

SCHEDULED MAINTENANCE	
Every day	Clean the process and regeneration filters: follow the instructions entitled <i>“Cleaning Filters” in this Section of the manual.</i>
Every month	Clean the outer surfaces of the cooling elements and the inlet air slot. follow the instructions in <i>“Cleaning the Cooling elements” in this Section of the manual.</i>
Every 3 months	Check the state of all the pipes, wiring and gears inside the machine.
Every 6 months	Check and if necessary replace all the machine filters.
	Check the tightness of the electric terminals.
Every 12 months	Have the Dew Point measurement probe calibrated (where installed): contact the CONAIR Technical Assistance Service.

Contact Conair
 Parts and Service
 Phone: 800-458-1960
 From outside of the
 United States,
 Call: 814 437 6861

If molding problems occur and the machine does not signal any faults, proceed with the following checks:

- 1** Make sure the process air temperature set on the parameter is that recommended by the producer of the material. *See “Operator Menu in Manual Mode” or “Operator Menu in Advance Mode” in the Operation section of this manual.*
- 2** Check that the plastic material stays in the hopper long enough to be completely dried.
- 3** Check the cleanness of the filters inside the machine.
- 4** Check the good condition of all the process air pipes and cooling pipes.
- 5** Check that the rotor is turning regularly .
- 6** Check the efficiency of the heating resistances and the relevant contactors even with a ampere meter.

Particular Checks In Case Of Molding Problems

(Continued)

Cleaning Filters

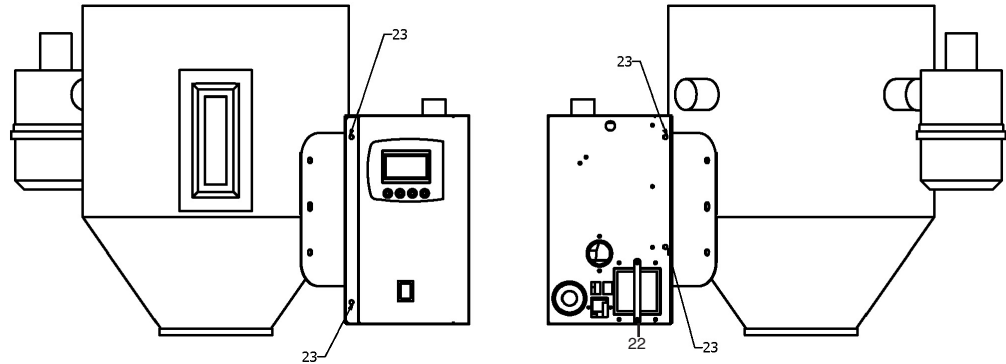

Figure 9



WARNING Burning Hazard.

Wait until the machine has cooled down to room temperature before working on internal parts.

IMPORTANT! Pay special attention and always wear suitable personal protective equipment!



CAUTION Risk of Damaging the Machine.

Replace the filters immediately if worn or damaged: using the machine with damaged filters will result in serious damage.

To clean the filters the dryer must be stopped and cooled down. In case it's working push the "off" key in the bottom right part of the display and wait until the dryer completes the cooling phase. Turn off the main switch 20 (see Figure 7).

To clean the process filter 6 (see Figure 7) unscrew the wing nut in the bottom part of it and remove the metallic cover. Also, unscrew the second wing nut that blocks the filter cartridge and finally remove the cartridge pulling it down. Clean the filter and inspect it for damage, in case it appear broken or could not be effectively cleaned, replace with a new one. Reassembly the filter taking care of the sealing elements.

To clean the regeneration filter cartridge 7 (see Figure 7) unscrew the screw-band in the bottom part, remove the cartridge pulling it up and clean it. Inspect the filter for damage, in case it appears broken or could not be effectively cleaned, replace with a new one and clean.

Never use **compressed air to clean** the filters.

Be aware that using the dryer without filters may result in serious damage and possible burning.

Cleaning the Cooling Elements



WARNING Electric Shock Hazard.

Make sure there is no live equipment nearby.



CAUTION Risk of Damaging the Machine.

When carrying out the following operations, take care not to let nuts and bolts (or other items) accidentally get into the battery compartment: an event of this nature can damage the machine and impair its operation.



CAUTION

Fan blades are present in the cooling side of the dryer, always be sure the machine is turned off before opening the frame.

Clean the cooling air inlet slots 21 (*see Figure 7*) and the air outlet slots 22 (*see Figure 7*) to remove any obstacle to the free flow of air. If necessary disassemble the dryer unit from the hopper removing the four screws 23 (*see Figure 9*). Pull on the side of the dryer case and then lift it since it's hooked in the upper part. Put the dryer on a plane and clean the cooling elements, clean from dust and any other dirt material that may obstruct the flow of air. Check the fan blades to be cleaned and if they can move freely. Check the cooling aluminum pipes for leakage, corrosion or squeezing and if not perfect have it changed by assistance service.

Troubleshooting

Before Beginning	6-2
A Few Words of Caution.....	6-2
Alarm & Warning List & Troubleshooting.....	6-2
Material Database.....	6-4
Spare Parts	6-5
Decommissioning The Machine.....	6-5
Electrical Wiring	6-6
Descriptions.....	6-11

Before Beginning

You can avoid most problems by following the recommended installation, operation and maintenance procedures outlined in this User Guide. If you have a problem, this section will help you determine the cause and tell you how to fix it.

Before you begin troubleshooting:

- Find any wiring, parts, and assembly diagrams that were shipped with your equipment. These are the best reference for correcting a problem. The diagrams will note any custom features or options not covered in this User Guide.
- Verify that you have all instructional materials related to the puller. Additional details about troubleshooting and repairing specific components are found in these materials.
- Check that you have manual for other equipment connected in the system. Troubleshooting may require investigating other equipment attached to, or connected with the puller.

A Few Words of Caution



WARNING: Improper installation, operation or servicing may result in equipment damage or personal injury.

This equipment should only be installed, adjusted, and serviced by qualified technical personnel who are familiar with the construction, operation, and potential hazards of this type of machine. All wiring, disconnects, and fuses should be installed and adjusted by qualified electrical technicians in accordance with electrical codes in your region. Always maintain a safe ground. Do not operate the equipment at power levels other than what is specified on the machine serial tag and data plate.



WARNING: Electrical hazard



Before performing maintenance or repairs on this product, disconnect and lock out electrical power sources to prevent injury from unexpected energization or start-up. A lockable device has been provided to isolate this product from potentially hazardous electricity.

Alarm & Warning List & Troubleshooting

An **Alarm** is a fault of the machine that can cause injury to the machine itself or the operator, so when occurring it will block all the device functions by means of the cutting of supply power to all internal devices except for the main control and display.

A **Warning** is an event that may compromise machine functionality but it does not represent a kind of danger, so the machine will continue to work. Only the warning message will be on the display until full functionality is recovered.

Alarm & Warning List & Troubleshooting (Continued)

Symptom	Possible Cause	Solution
KEYBOARD ERROR	Problem with the keyboard	Check the RJ45 cable
TX SENSOR BROKEN	A temperature probe sensor is broken or disconnected. X stand for id number of the broken sensor.	Check the sensor's connection on the board; make a visual check of the sensor and its cable if it might be damaged.
01-ALARM HEATING	The real process temperature is higher than the security one settled by means of the security delta one. The differential between T5 and T4 is higher than the parameter set.	Process set has been decreased too much while dryer was running. Process filter to be cleaned. One temperature sensor is removed from the hopper. Static relays are broken.
02- ALARM REGEN.	Thermal protection on the regeneration heating chamber. A mechanical safety thermostat installed in the heater body has been engaged	Check the air flow outside the regeneration and if the regeneration blower is working. Check and clean the regeneration filter.
03- ALARM ST	Thermal protection of the processing chamber. A mechanical safety thermostat installed in the heater body has been engaged	Check the pipe connection between the dryer and the heating chamber; check the connection of T4 and T5. Check the process blower and process filter.
04- ALARM B-P	Thermal protection of the processing blower.	Check the processing filter and make sure that there is enough processing air flow. Check the cooling fan and clean the air path.
05 – ALARM T BLOW.	The temperature on the process blower inlet is too high.	Check heating exchanger condition and if the cooling fan is working.
06-BLOCKED BLOW.	The process blower is not running properly or is blocked.	Process blower is in thermal protection, wait until cooled; fuse broken inside the blower, connector on the main board unplugged. Check for blower free rotation.
07- OVERT. REG.	The regeneration temperature is too high.	Check regeneration filter, regeneration solid state relays.
NO CHARGE LOAD#1	Material missing on loader 1.	Check the material source if is enough, make sure that all the vacuum line is free and the vacuum level is good enough. Clean the vacuum filter.
NO CHARGE LOAD#2	Material missing on loader 2.	Check if there is enough source material. Make sure that all the vacuum line is free and the vacuum level is good. Clean the vacuum filter and check the sealing of the cup.
36-CLEAN SUCK FILT.	Vacuum filter.	Clean the vacuum filter behind the dryer.
32-WARNING DP-S	Dew point lower than settled.	Wait for an hour and if not better check for all the dryer efficiency.
30- CLEAN FILTER	Processing filter.	Clean the processing filter inside the dryer by opening the front door.
40- WRONG REQUEST	This is appearing when you select an air flow lower than the minimum. Only work in manual mode.	Increase the processing blower airflow in the user menu.
41- WRONG REQUEST	This happen when you have selected a throughput higher than the hopper capacity. Only valid in advance mode.	Reduce the throughput required.

Material Database

MATERIAL DATABASE				
Material		B.D.	residence time	Process temperature
code	description	kg/dm ³	h	°C
ABS mold.	Acrilonitril-butadien-stirene	0,6	3	80
ABS ext	Acrilonitril-butadien-stirene extrusion	0,6	3,5	85
ABS/PC	Acrilonitril-butadien-stirene + policarbonato	0,65	3	100
ASA	Polimero aggraffato elastomero AN/A stirene	0,6	3	90
CA	Acetato di cellulosa	0,5	2,5	70
CAB	Acetobutirrato di cellulosa	0,5	2,5	70
CP	Propionato di cellulosa	0,6	4	75
EVA	Etilene Vinilacetato	0,6	3	80
Ionomere Pe ion	ionomeri	0,56	3,5	75
EPDM		0,52	4	80
LCP	Polimero cristalli liquidi	0,6	4	150
PA 6	Poliamide 6	0,65	5	75
PA 66	Poliamide 6, 6/10	0,65	5	80
PA66+35FV	Poliamide + glass fiber 35%	0,85	5	80
PA 12	Poliamide 12	0,65	3	75
PA 11	Poliamide 11, 12	0,65	5	75
PC	Policarbonato	0,7	3	120
PC for CD	Policarbonato for optical disk	0,7	4	120
PC + PBT	policarbonato + polibutileneteraftalato	0,7	3,5	110
PE	Polietilene	0,6	3	90
PE (40% nerofumo)	Polietilene (40% nerofumo)	0,6	5	85
PEEK	Polieterchetone	0,6	4	155
PEI	Polieterimmide	0,6	4,5	155
PEN	Polietilenaftalato	0,85	5	170
PES	Polietersulfone	0,7	4	155
PES	Polietersulfone (estrusione)	0,7	4	180
PET	Polietilenteraftalato (iniezione)	0,85	4	130
PET ext	Polietilenteraftalato (preforme-estrusione)	0,85	6	170
PETG	Polietilenteraftalato (modif. con glicole)	0,6	4,5	65
PBT	Polibutileneteraftalato	0,7	3,5	125
PI	Poliimmide	0,6	2,5	120
PMMA	Polimetilmetacrilato	0,65	4	80
POM	Polioossimetilene / Poliacetale	0,6	3	100
PP	Polipropilene	0,5	2,5	90
PP ext	Polipropilene estrusione	0,5	2	100
PP GF20	Polipropilene +20% fibra vetro	0,63	3	90
PPGF30	Polipropilene +30% fibra vetro	0,68	3	90
PP (40% talco)	Polipropilene (40% talco)	0,6	2,5	90
PPO	Polifenilenoossido	0,5	2,5	105
PPS	Polifenilensulfide	0,6	3,5	140
PS	Polistirene	0,55	2	80
PSU	Polisulfone	0,65	3,5	135
	Polisulfone (estrusione)	0,65	3	170
PSU GF20	Polisulfone +20% fibra vetro	0,84	3	150
PUR	Poliuretano	0,7	3	85
PVC	Polivinilcloruro	0,8	1,5	70
SAN	Stirene-acrilonitrile	0,5	2,5	80
SB	Stirene-butadiene	0,6	2	80
TPE	Elastomero termoplastico	0,65	3	110
TPU	Elastomeri PUR termoplastici	0,65	3	90

Spare Parts

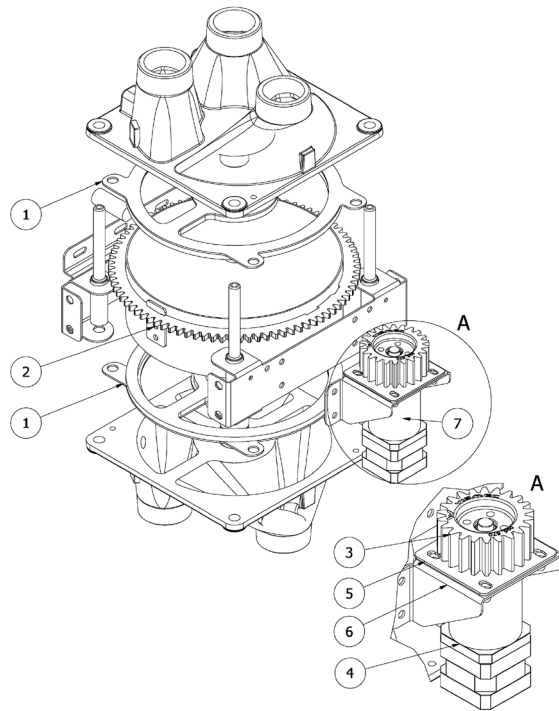
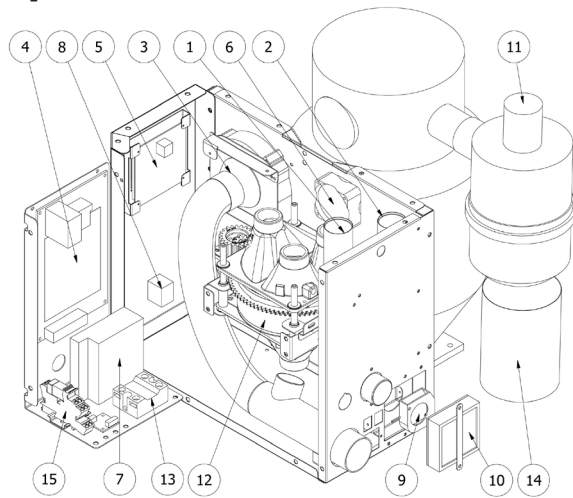

Spare Parts Micro Wheel 1 (MW1)		
Conair Part #	Item	Part Description
26721701	1, 2	Process / Regeneration heater
26721702	3	Process Blower MW1 / Regeneration Blower MW2
26721703	4	Main Electric Board DB239
26721704	5	Display LCD DB237
26721705	6	Cooling Fan, 5.8W
26721706	7	Switching Power Supply 50W 24VDC
26721707	8	Main Switch
26721708	9	Regeneration Blower
26721709	10	Regeneration Filter
26721710	11	Complete Process Filter
26721711	12	Rotor Group DP14
26721712	13	Static Relay
26721713	14	Process Cartridge filter
26721714	15	2 way 24vdc Relay

Spare Parts Micro Wheel 1 (MW1)		
Conair Part #	Item	Part Description
Wheel		
26721715	1	Complete Gasket, 3 holes 150 mm
26721716	2	Spare Rotor with Gear DP14
26721717	3	Gear M2 Z22 for Stepper
26721718	4	Gear Motor, 35x35
26721719	5	Gear Motor Support
26721720	6	Gear Motor Support
26721721	7	Complete Rotor Group

Optional items										
	Loader adapter		Drainport / Throat Adapter	Alarm Kit	Dew Point Sensor Kit	Network Connection Kit	Weekly Timer Kit	Filter Check Kit	Remote Control Kit	Redundant Control Kit
Dryer Model	Hand fill	TLM/TLR	Part #	Part #	Part #	Part #	Part #	Part #	Part #	Part #
MW1-0.2	Future	1819750901	1819750101	1819750201	1819750301	1819750401	1819750501	1819750601	1819750701	1819750801
MW1-0.5	Future	1819750902	1819750101	1819750201	1819750301	1819750401	1819750501	1819750601	1819750701	1819750801
MW1-1.0	Future	1819750903	1819750102	1819750201	1819750301	1819750401	1819750501	1819750601	1819750701	1819750801
MW2-1.0	Future	1819750903	1819750102	1819750201	1819750301	1819750401	1819750501	1819750601	1819750701	1819750801
MW2-1.75	Future	1819750903	1819750102	1819750201	1819750301	1819750401	1819750501	1819750601	1819750701	1819750801

Decommissioning The Machine

When the machine's life cycle comes to an end, it must be disconnected from the electrical supplies and uninstalled from its working position. The machine must be disposed of in full compliance with statutory laws in the country where it is installed.



Attention

After having removed the machine from its working position, permanently affix to it a notice with the message: "MACHINE TO BE SCRAPPED: DO NOT USE."

Electrical Wiring

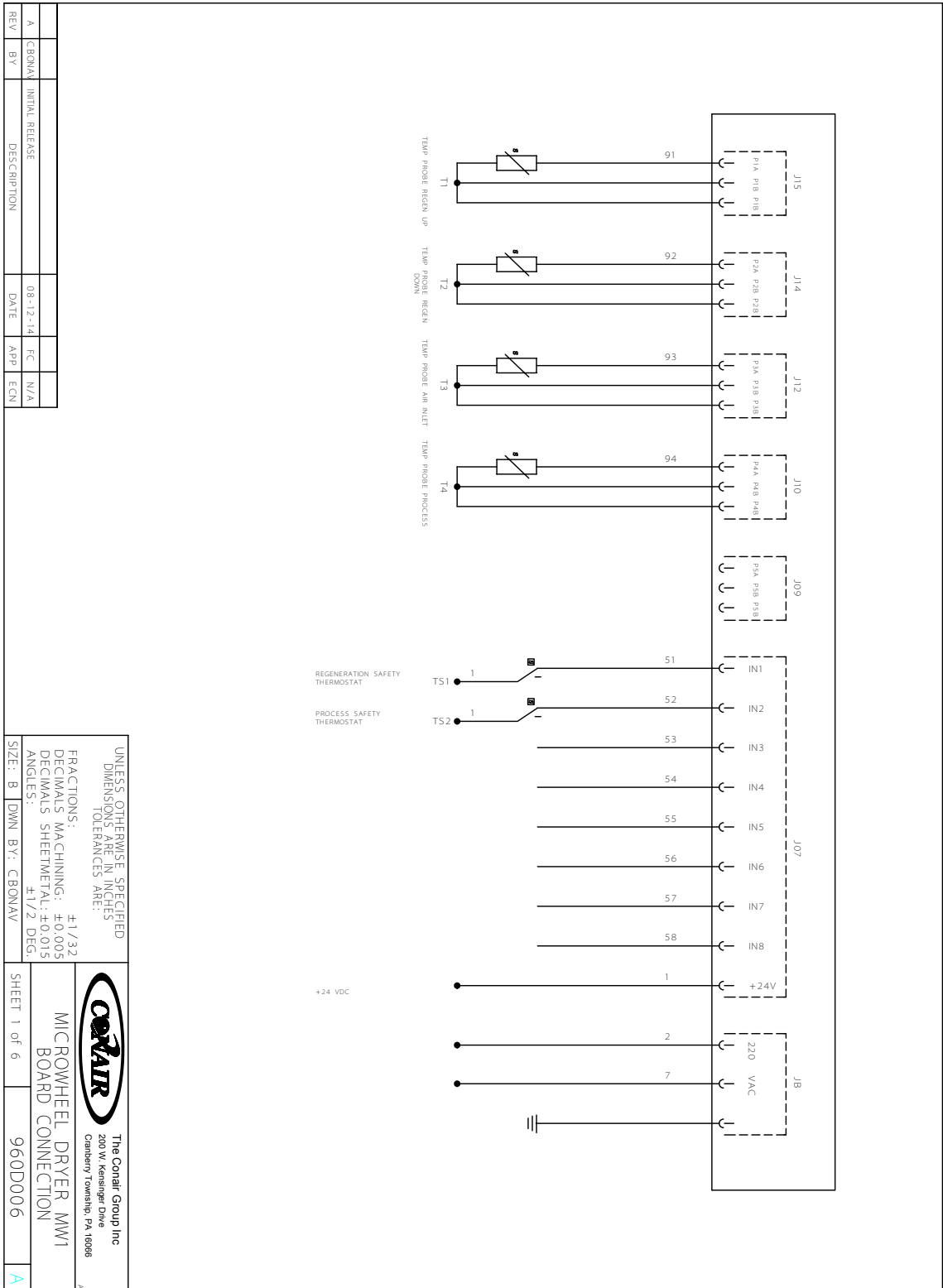

(Continued)

Electrical Wiring (Continued)

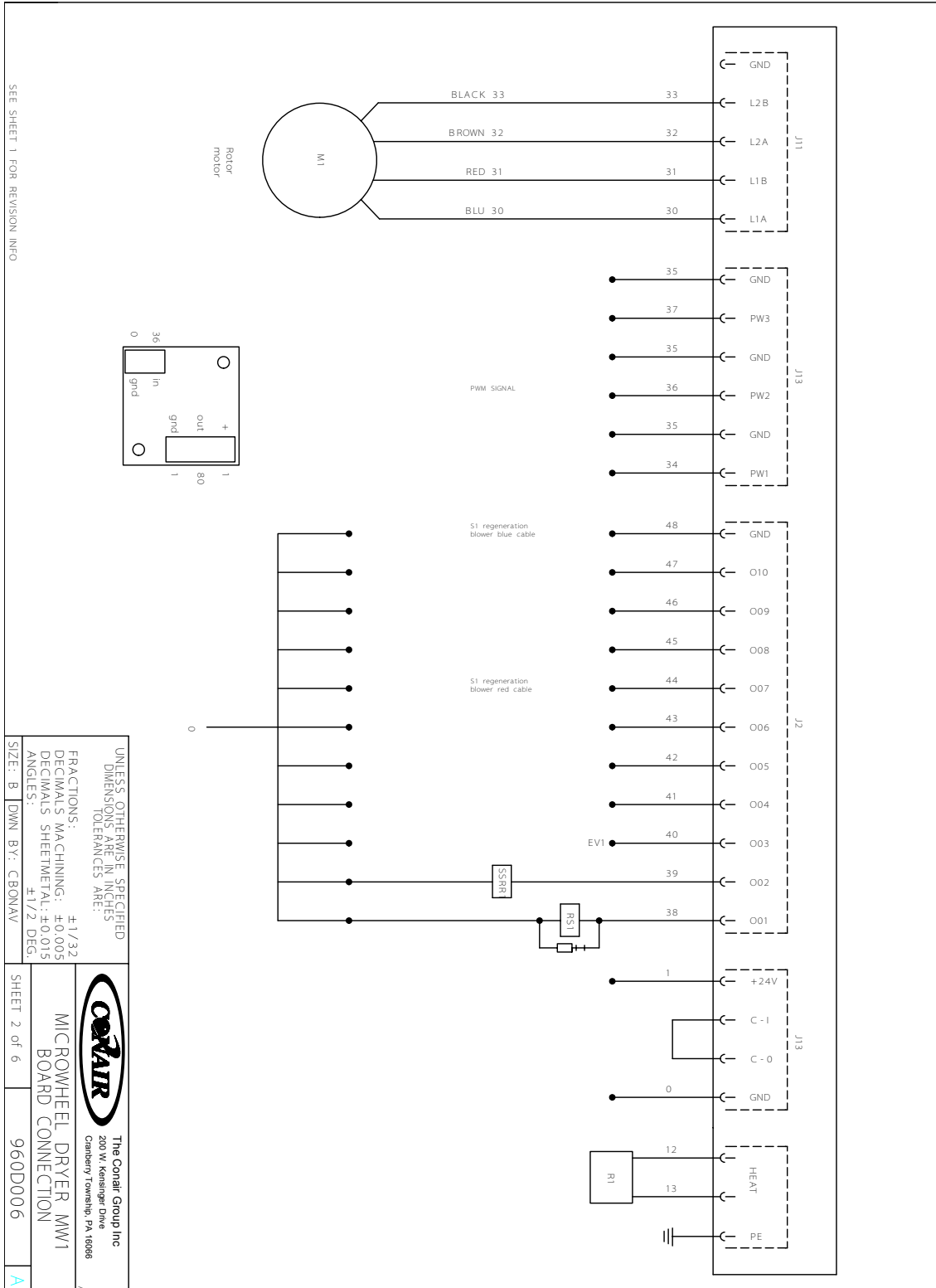

(Continued)

Electrical Wiring (Continued)

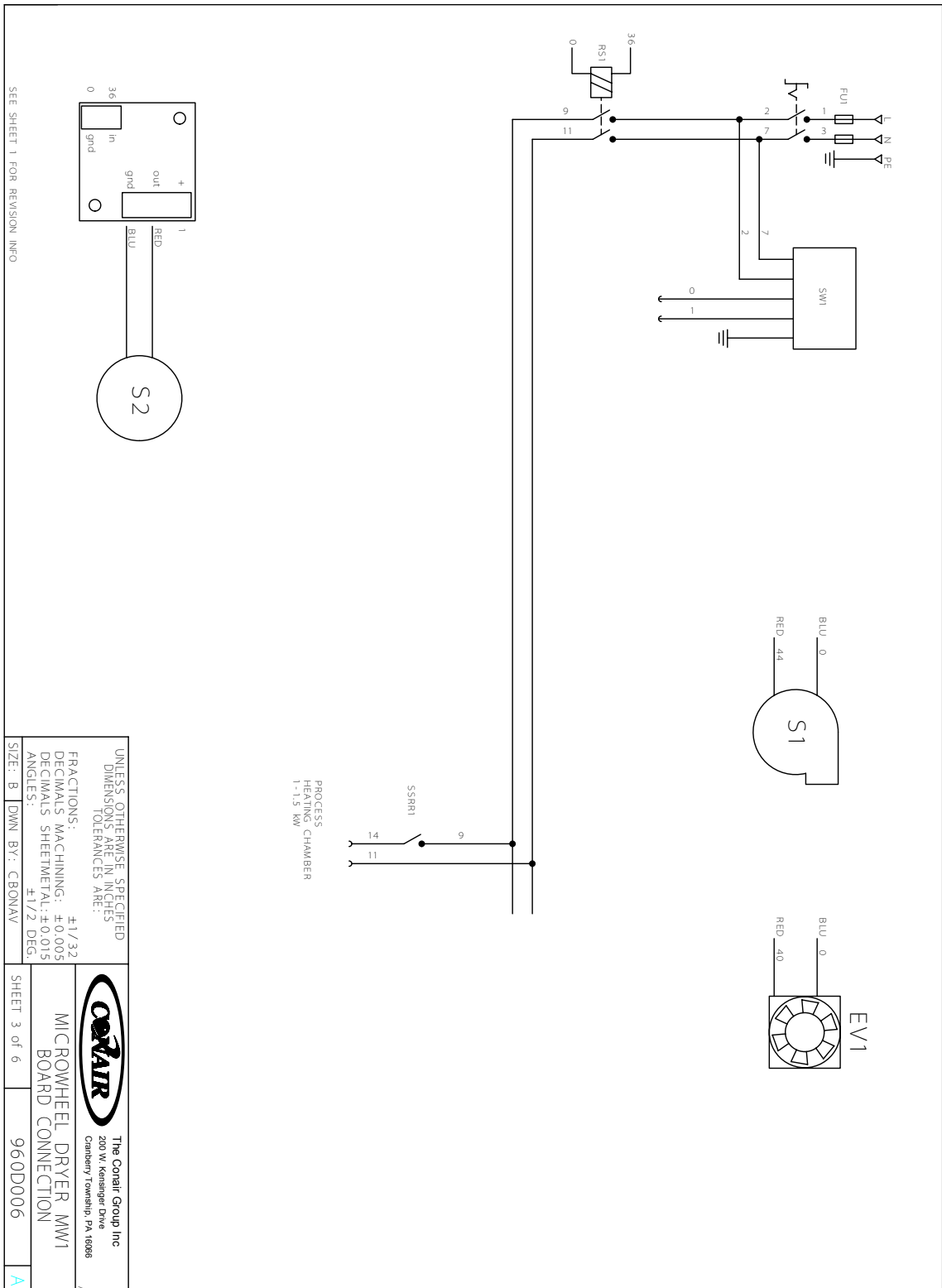

(Continued)

Electrical Wiring (Continued)

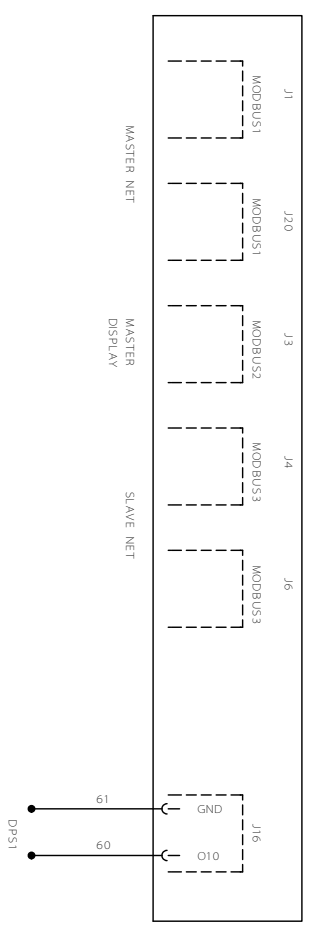

SEE SHEET 1 FOR REVISION INFO

UNLESS OTHERWISE SPECIFIED
DIMENSIONS ARE IN INCHES
TOLERANCES ARE:
FRACTIONS: ±1/32
DECIMALS MACHINING: ±0.005
DECIMALS SHEETMETAL: ±0.015
ANGLES: ±1/2 DEG.
SIZE: B DWN. BY: C BONAV

	
The Covair Group Inc 200 W. Kenelmer Drive Canabury Township, PA 16066	
MICROWHEEL DRYER MW1 BOARD CONNECTION	SHEET 4 of 6
960D006	A

(Continued)

Electrical Wiring (Continued)

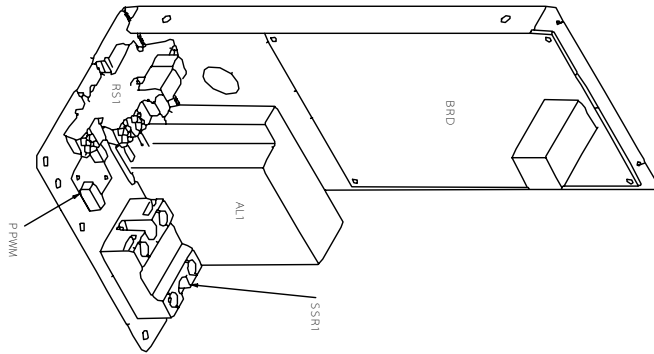
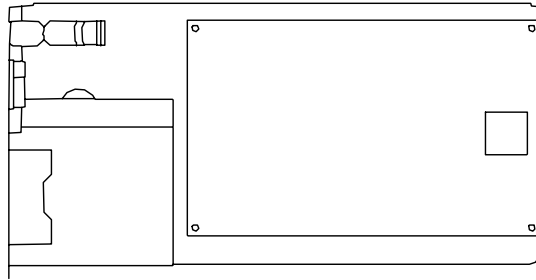

ELECTRIC PLANT COMPONENTS LAYOUT
DPW 14

DP90	DP80
FU1	6.3A
FU2	3A

FU1 on IEC female plug
connector

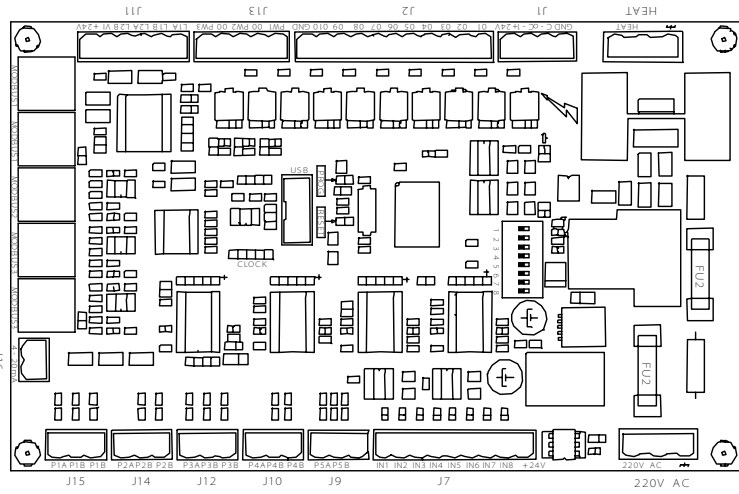

BRD BOARD LAYOUT

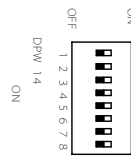

SEE SHEET 1 FOR REVISION INFO

UNLESS OTHERWISE SPECIFIED
DIMENSIONS ARE IN INCHES
TOLERANCES ARE:
FRACTIONS: ±1/32
DECIMALS MACHINING: ±0.005
DECIMALS SHEETMETAL: ±0.015
ANGLES: ±1/2 DEG.
SIZE: B | DWN BY: CROMAY



The Conair Group Inc
200 W. Ackleygier Drive
Cranberry Township, PA 15066

MICROWHEEL DRYER MW1
COMPONENTS LAYOUT

SHEET 5 of 6

960D006

A

Descriptions

ID#	DESCRIPTION	CODE
R1	Regeneration heater	
R2	Processing heater	
TS1	Safety thermostat R1	
TS2	Safety thermostat R2	
S1	Regeneration blower	
S2	Processing blower	
S3	Feeding system blower	Option
T1	Temperature probe regeneration up	
T2	Temperature probe regeneration down	
T3	Temperature probe air inlet	
T4	Temperature probe process	
T5	Temperature probe safety	
RF2	RC filter blower S2	
RF3	RC filter blower S3	Option
SW1	CC power switching source	
EV1	Cooling fan	
EV2	Vacuum blower cleaning fan	Option
M1	Step motor	
RS1	Breaker	
QS1	General power switching	
Fu1	General fuse	
FU2	Regeneration heating fuse	
FU3	Process heating fuse	
XS1	Connectors	
SSRR1	Solid state relay 1	
SSRR2	Solid state relay 2	
CLS1	Receiver flap sensor C1	Option
CLS2	Receiver flap sensor C2	Option
EC1	Vacuum braking valve C1	Option
EC2	Vacuum braking valve C2	Option
ECP1	Proportional valve	Option
BRD	Master board	
DPY	Display	
DPS1	Dew point sensor	Option
WT1	Weekly timer	Option
PS1	Pressure switch processing filter	Option
AL1	External alarm	

SEE SHEET 1 FOR REVISION INFO

UNLESS OTHERWISE SPECIFIED
DIMENSIONS ARE IN INCHES
TOLERANCES ARE:
FRACTIONS: ±1/32
DECIMALS MACHINING: ±0.005
DECIMALS SHEETMETAL: ±0.015
ANGLES: ±1/2 DEG

SIZE: B | DWN BY: CBONAV

SHEET 6 of 6

960D0006

A



The Conair Group Inc
200 W. Kensington Drive
Cranberry Township, PA 15066

MICROWHEEL DRYER MW1
DESCRIPTIONS

We're Here to Help

Conair has made the largest investment in customer support in the plastics industry. Our service experts are available to help with any problem you might have installing and operating your equipment. Your Conair sales representative also can help analyze the nature of your problem, assuring that it did not result from misapplication or improper use.

Additional manuals and prints for your Conair equipment may be ordered through the Customer Service or Parts Department for a nominal fee. Most manuals can be downloaded free of charge from the product section of the Conair website. www.conairgroup.com

How to Contact Customer Service

To contact Customer Service personnel, call:



 **NOTE:** Normal operating hours are 8:00 am - 5:00 pm (EST). After hours emergency service is available at the same phone number.

You can commission Conair service personnel to provide on-site service by contacting the Customer Service Department.

Before You Call...

If you do have a problem, please complete the following checklist before calling Conair:

- Make sure power is supplied to the equipment.
- Make sure that all connectors and wires within and between control systems and related components have been installed correctly.
- Check the troubleshooting guide of this manual for a solution.
- Thoroughly examine the instruction manual(s) for associated equipment, especially controls. Each manual may have its own troubleshooting guide to help you.
- Check that the equipment has been operated as described in this manual.
- Check accompanying schematic drawings for information on special considerations.

Equipment Guarantee

Conair guarantees the machinery and equipment on this order, for a period as defined in the quotation from date of shipment, against defects in material and workmanship under the normal use and service for which it was recommended (except for parts that are typically replaced after normal usage, such as filters, liner plates, etc.). Conair's guarantee is limited to replacing, at our option, the part or parts determined by us to be defective after examination. The customer assumes the cost of transportation of the part or parts to and from the factory.

Performance Warranty

Conair warrants that this equipment will perform at or above the ratings stated in specific quotations covering the equipment or as detailed in engineering specifications, provided the equipment is applied, installed, operated and maintained in the recommended manner as outlined in our quotation or specifications.

Should performance not meet warranted levels, Conair at its discretion will exercise one of the following options:

- Inspect the equipment and perform alterations or adjustments to satisfy performance claims. (Charges for such inspections and corrections will be waived unless failure to meet warranty is due to misapplication, improper installation, poor maintenance practices or improper operation.)
- Replace the original equipment with other Conair equipment that will meet original performance claims at no extra cost to the customer.
- Refund the invoiced cost to the customer. Credit is subject to prior notice by the customer at which time a Return Goods Authorization Number (RGA) will be issued by Conair's Service Department. Returned equipment must be well crated and in proper operating condition, including all parts. Returns must be prepaid.

Purchaser must notify Conair in writing of any claim and provide a customer receipt and other evidence that a claim is being made.

Warranty Limitations

Except for the Equipment Guarantee and Performance Warranty stated above, Conair disclaims all other warranties with respect to the equipment, express or implied, arising by operation of law, course of dealing, usage of trade or otherwise, including but not limited to the implied warranties of merchantability and fitness for a particular purpose.