

User Guide

MT Vacuum Sizing Tanks

with manual control,
optional potentiometer control,
or optional PAVC control

Installation

Operation

Maintenance

Troubleshooting

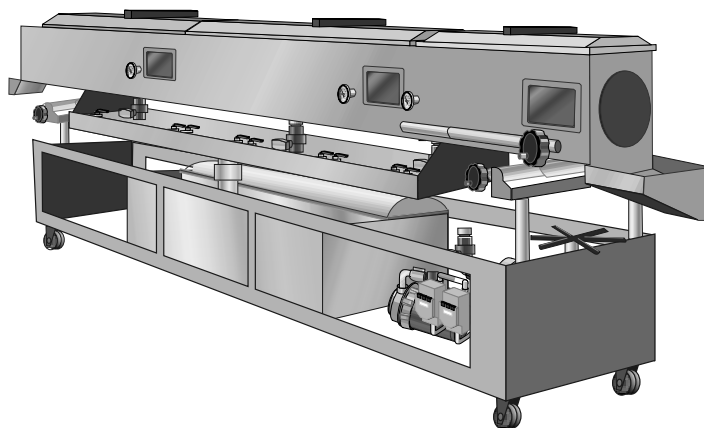

*Instant Access
Parts and Service
(800) 458-1960
(814) 437-6861*

CONAIR™

The Conair Group, Inc.
One Conair Drive
Pittsburgh, PA 15202
P: 412 312 6000
F: 412 312 6227
www.conairnet.com

UGE046/0303

Please record your equipment's model and serial number(s) and the date you received it in the spaces provided.

It's a good idea to record the model and serial number(s) of your equipment and the date you received it in the User Guide. Our service department uses this information, along with the manual number, to provide help for the specific equipment you installed.

Please keep this User Guide and all manuals, engineering prints and parts lists together for documentation of your equipment.

Date:
Manual Number: UGE046/0303
Serial number(s):
Model number(s):

The Conair equipment described in this publication is covered by:
U.S. Patent numbers 5,340,295; 5,464,335; 5,645,861; and 5,648,102.

DISCLAIMER: The Conair Group, Inc., shall not be liable for errors contained in this User Guide or for incidental, consequential damages in connection with the furnishing, performance or use of this information. Conair makes no warranty of any kind with regard to this information, including, but not limited to the implied warranties of merchantability and fitness for a particular purpose.

TABLE OF CONTENTS

INTRODUCTION	1-1
Purpose of the User Guide	1-2
How the guide is organized	1-2
Your responsibilities as a user	1-2
ATTENTION: Read this so no one gets hurt	1-3
How to use the lockout device	1-4
DESCRIPTION	2-1
What is the MT tank?	2-2
Typical applications	2-2
How it works: Product flow	2-3
How it works: Water system	2-4
How it works: Vacuum system	2-5
Specifications: MT Vacuum Sizing Tanks	2-6
Specifications: Main power supply wire	2-6
Available options	2-7
INSTALLATION	3-1
Unpacking the boxes	3-2
Preparing for installation	3-3
Setting up and aligning the MT tank	3-4
Connecting the main power	3-5
Connecting the water supply	3-6
Connecting a chiller	3-7
Testing the installation	3-8
OPERATION	4-1
MT Tank control features	4-2
Preparing for operation	4-4
Vacuum modes	4-5
Cooling modes and immersion rollers	4-5
Centering the tank with the extrudate	4-6
Threading the extrudate	4-7
Starting an MT tank with manual controls	4-8
Starting an MT tank with a 10-turn potentiometer	4-10
Adjusting water flow	4-12
Adjusting water levels	4-13
Stopping the MT tank	4-14
MAINTENANCE	5-1
Preventative maintenance schedule	5-2
Inspecting gaskets	5-4
Replacing gaskets	5-4
Cleaning the filter cartridge	5-5
Cleaning the suction screens	5-5

TABLE OF CONTENTS

MAINTENANCE CONTINUED5-1

Lubricating the tank components	5-6
Cleaning the vacuum tank	5-6
Cleaning the reservoirs	5-7
Cleaning the spray bars	5-7
Adjusting the floats	5-8
Inspecting the electrical connections	5-9

TROUBLESHOOTING6-1

Before beginning	6-2
A few words of caution	6-2

DIAGNOSTICS

How to identify the cause of a problem	6-3
Water system problems	6-4
Vacuum system problems	6-6
Electrical problems	6-9
Product quality problems	6-9

REPAIR

Checking electrical connections	6-10
Checking and resetting motor starters	6-12
Checking and replacing the 10-turn potentiometer	6-12
Cleaning the automatic vent valve	6-13

APPENDIX

Service/Warranty information	Appendix A
Control Techniques Commander SE Drive start-up and parameter set-up	Appendix B

Manufacturers instructions for MT vacuum sizing tank components can be found in the Appendix or within the instruction packet that was shipped with this machine.

PARTS/DIAGRAMS

This section has been provided for you to store spare parts lists and wiring, plumbing or assembly diagrams.

INTRODUCTION

- *Purpose of the User Guide1-2*
- *How the guide is organized1-2*
- *Your responsibilities as a user .1-2*
- *ATTENTION: Read this so
no one gets hurt1-3*
- *How to use the lockout device .1-4*





PURPOSE OF THE USER GUIDE

This User Guide describes the Conair MT vacuum sizing tanks with manual, potentiometer or PAVC controls. It explains step-by-step how to install, operate, maintain and repair this equipment.

Before installing this product, please take a few moments to read the User Guide and review the diagrams and safety information in the instruction packet. You also should review manuals covering associated equipment in your system. This review won't take long, and it could save you valuable installation and operating time later.

HOW THE GUIDE IS ORGANIZED

Symbols have been used to help organize the User Guide and call your attention to important information regarding safe installation and operation.

-  Symbols within triangles warn of conditions that could be hazardous to users or could damage equipment. Read and take precautions before proceeding.
-  Numbers within shaded squares indicate tasks or steps to be performed by the user.
-  A diamond indicates the equipment's response to an action performed by the user.
-  An open box marks items in a checklist.
-  A shaded circle marks items in a list.

YOUR RESPONSIBILITY AS A USER

You must be familiar with all safety procedures concerning installation, operation and maintenance of this equipment. Responsible safety procedures include:

- Thorough review of this User Guide, paying particular attention to hazard warnings, appendices and related diagrams.
- Thorough review of the equipment itself, with careful attention to voltage sources, intended use and warning labels.
- Thorough review of instruction manuals for associated equipment.
- Step-by-step adherence to instructions outlined in this User Guide.

We design equipment with the user's safety in mind. You can avoid the potential hazards identified on this machine by following the procedures outlined below and elsewhere in the User Guide.

 **ATTENTION:
READ THIS SO NO
ONE GETS HURT**



WARNING: Improper installation, operation or servicing may result in equipment damage or personal injury.

This equipment should be installed, adjusted, and serviced by qualified technical personnel who are familiar with the construction, operation and potential hazards of this type of machine.

All wiring, disconnects and fuses should be installed by qualified electrical technicians in accordance with electrical codes in your region. Always maintain a safe ground. Do not operate the equipment at power levels other than what is specified on the the machine serial tag and data plate.

You should keep the area around the tank clean and free from pooling water. We recommend installing a grate or drain system beneath this equipment to prevent water from pooling around the tank.



WARNING: Voltage hazard

This equipment is powered by three-phase alternating current, as specified on the machine serial tag and data plate.

A properly sized conductive ground wire from the incoming power supply must be connected to the chassis ground terminal inside the electrical enclosure. Improper grounding can result in severe personal injury and erratic machine operation.

Always disconnect and lock out the incoming main power source before opening the electrical enclosure or performing non-standard operating procedures, such as routine maintenance. Only qualified personnel should perform troubleshooting procedures that require access to the electrical enclosure while power is on.

HOW TO USE THE LOCKOUT DEVICE:

WITH MANUAL MOTOR STARTERS



⚠ CAUTION: Before performing maintenance or repairs on this product, you should disconnect and lock out electrical power sources to prevent injury from unexpected energization or start-up. A lockable device has been provided to isolate this product from potentially hazardous electricity.

⚠ WARNING: Before removing lockout devices and returning switches to the ON position, make sure that all personnel are clear of the machine, tools have been removed and all safety guards reinstalled.

Lockout is the preferred method of isolating machines or equipment from energy sources. Your Conair product is equipped with one of the lockout devices pictured below. To use the lockout device:

- 1** Stop or turn off the equipment.
- 2** Isolate the equipment from electrical power.
- 3** Turn the rotary disconnect switch to Off, or O position.
- 4** Shut the yellow lid covers on both boxes and secure the lids with an assigned lock or tag.



- 5** The equipment is now locked out.

HOW TO USE THE LOCKOUT DEVICE:

WITH THE OPTIONAL PAVC OR 10-TURN POTENTIOMETER CONTROL



- 1** Stop or turn off the equipment.
- 2** Isolate the equipment from electrical power.
- 3** Turn the rotary disconnect switch to Off, or O position.
- 4** Secure the device with an assigned lock or tag.
- 5** The equipment is now locked out.

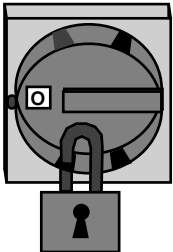
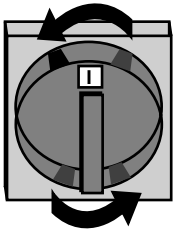

DESCRIPTION

- *What is the MT Tank?2-2*
- *Typical applications2-2*
- *How it works: Product flow2-3*
- *How it works: Water system . . .2-4*
- *How it works: Vacuum system . .2-5*
- *Specifications: MT*
 - vacuum sizing tank2-6*
- *Specifications: Main power*
 - supply wire2-6*
- *Available options2-7*

WHAT IS THE MT TANK?

The MT vacuum sizing tank produces hollow tubing or hollow profiles from extruded plastic material in the shape and size determined by your extrusion die and calibration tool.

All MT vacuum sizing tanks use an air/water separation process that provides extremely stable vacuum over wide vacuum ranges, improves product tolerances, minimizes scrap, allows for repeatability and improves surface finishes.

TYPICAL APPLICATIONS

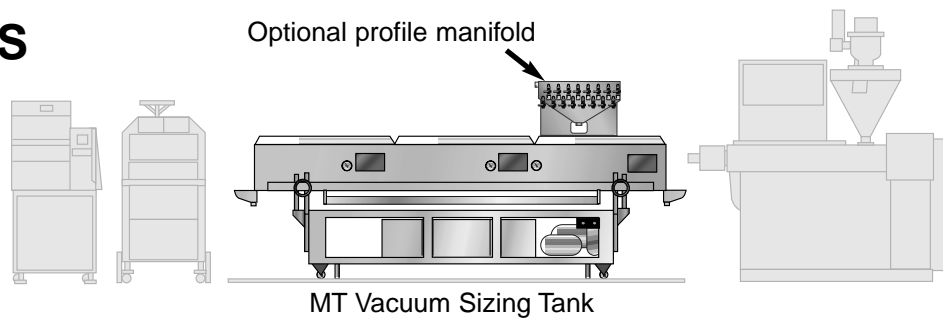

The MT Vacuum Sizing Tanks are available in a number of configurations to suit your application needs, including right-to-left or left-to-right orientation (See *SPECIFICATIONS*). The process descriptions and illustrations in this document assume that you are using a right-to-left unit.

The MT tanks can be used to size, calibrate and cool any extruded product in applications that require:

- tube or profile capacity up to 8.625 inch (219 mm) diameter.
- tank length of 7 to 22 feet (2134 to 6706 mm).
- longitudinal load of up to 1500 lbs (680 kg) to withstand the pull of extrudate through a calibration tool.

The MT tanks are designed for use with city, tower or chilled water. You may choose to treat the water to prevent algae build-up, but do not use deionized water, brine or other corrosive water mixtures unless your tank has been specially designed for such mixtures.

The MT tank may be used for non-contact extrusion. If your non-contact application requires the same vacuum level in several chambers, you should not place bushings or tooling in the bulkheads between these vacuum chambers.

HOW IT WORKS: PRODUCT FLOW

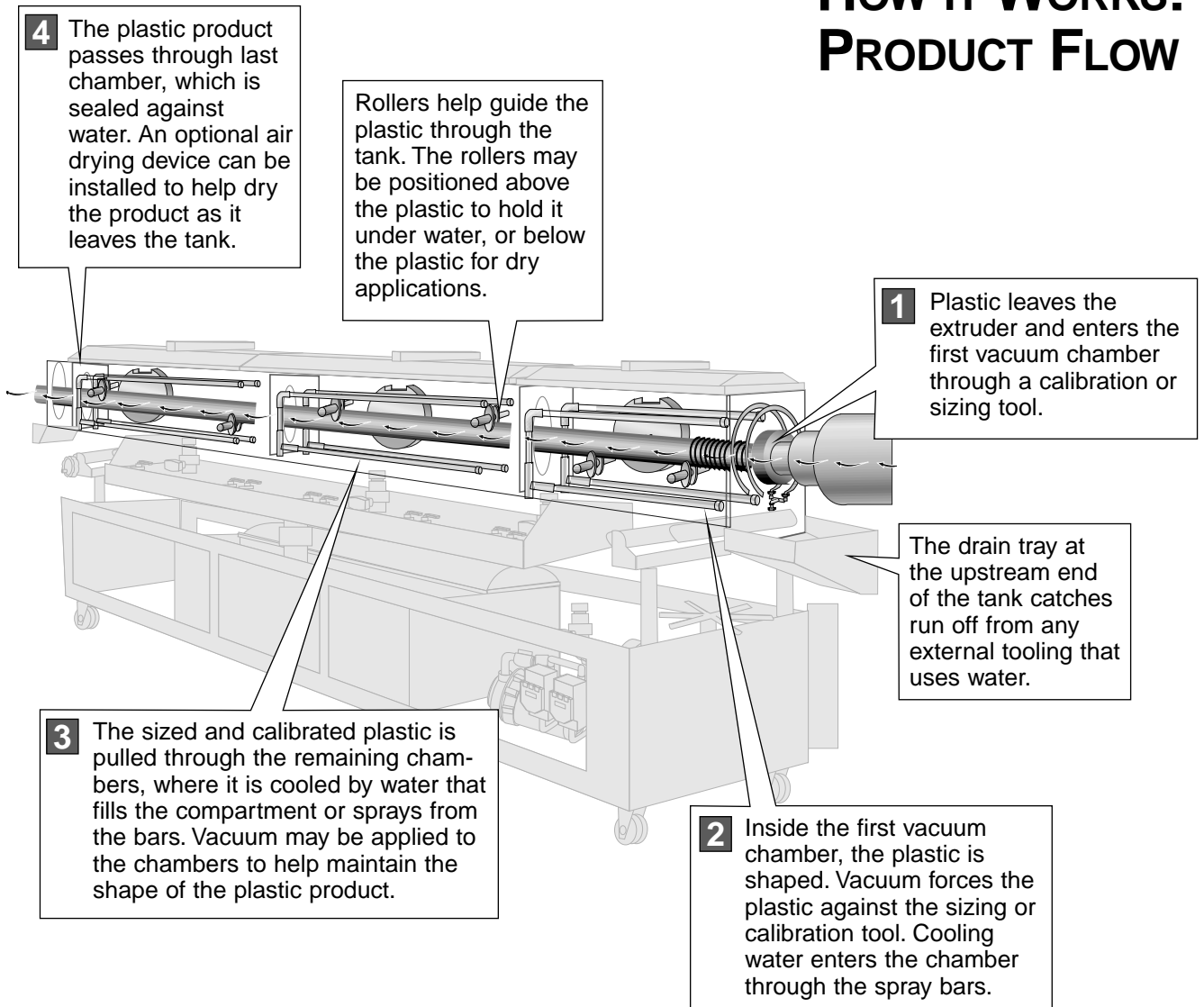

The profile manifold is optional on the MT Tank

On MT models with the optional profile manifold, vacuum and water lines can be plumbed directly to the calibration tool for sizing and cooling solid profiles.

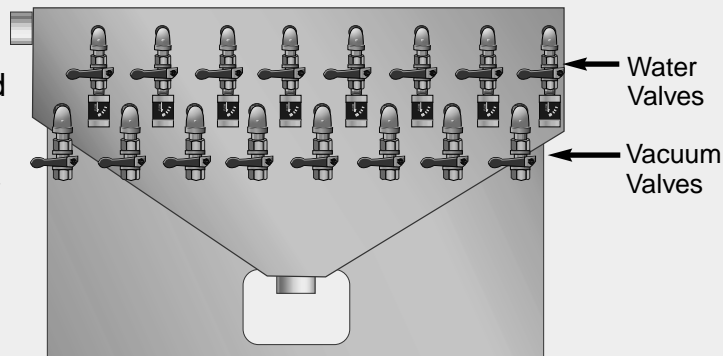

HOW IT WORKS: WATER SYSTEM

A recirculating water system helps cool the sized and calibrated plastic as it is pulled through the sizing tank.

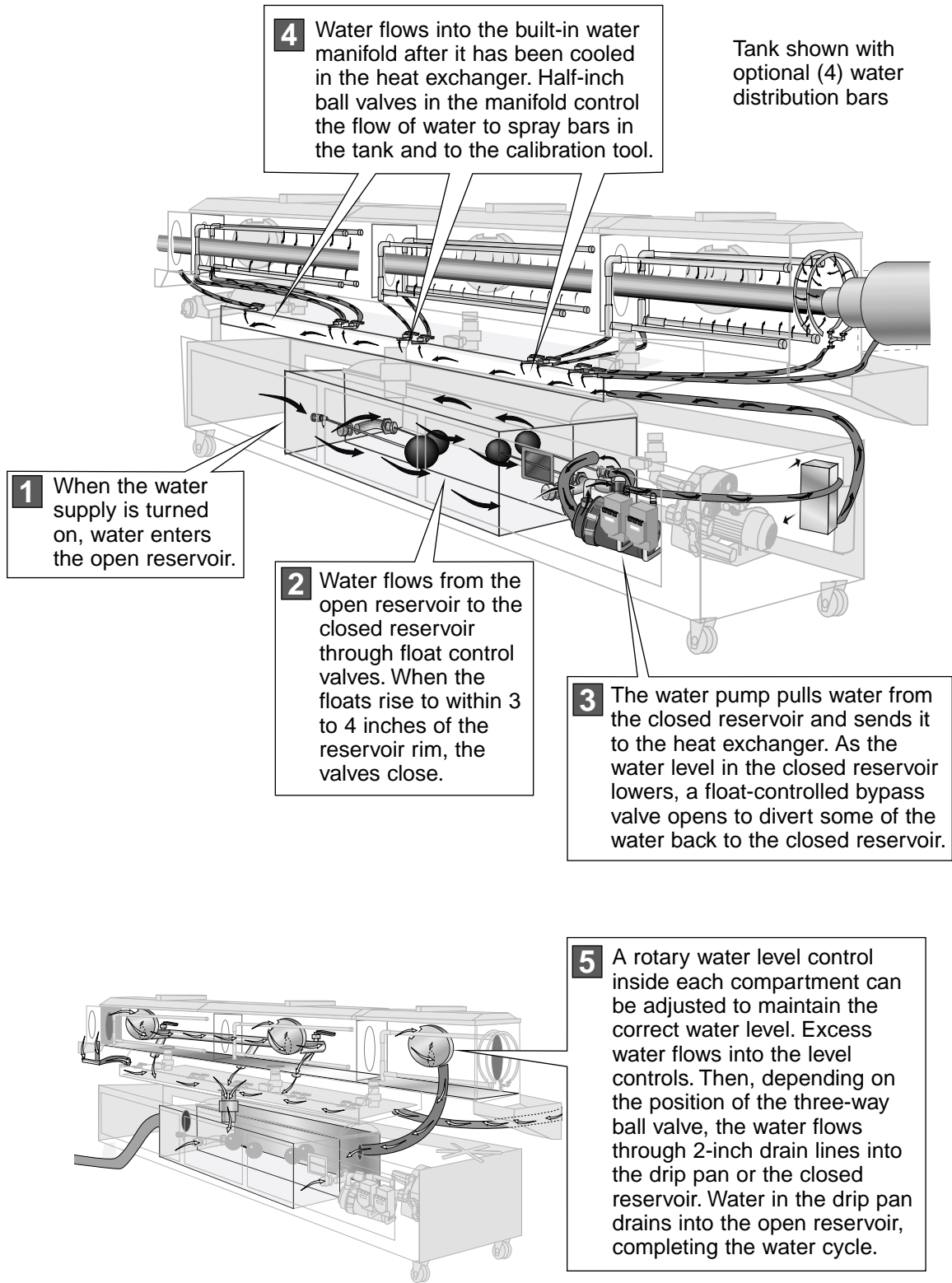

HOW IT WORKS: VACUUM SYSTEM

Through a process called air/water separation, the MT vacuum sizing tank provides vacuum stability, which is critical to creating and maintaining consistent shape and surface finish of the plastic product. Separate water and air pipes lead to a closed water reservoir. The vacuum pump evacuates the air in the closed reservoir, not the water, minimizing surges in vacuum levels.

1 Only one vacuum level can be achieved throughout the tank with a single pump system. An optional dual vacuum pump system allows one vacuum level in the first chamber and a different vacuum level in the remaining chambers.

Optional independent vacuum control to each compartment can be accomplished by adjusting the optional manual ball valves.

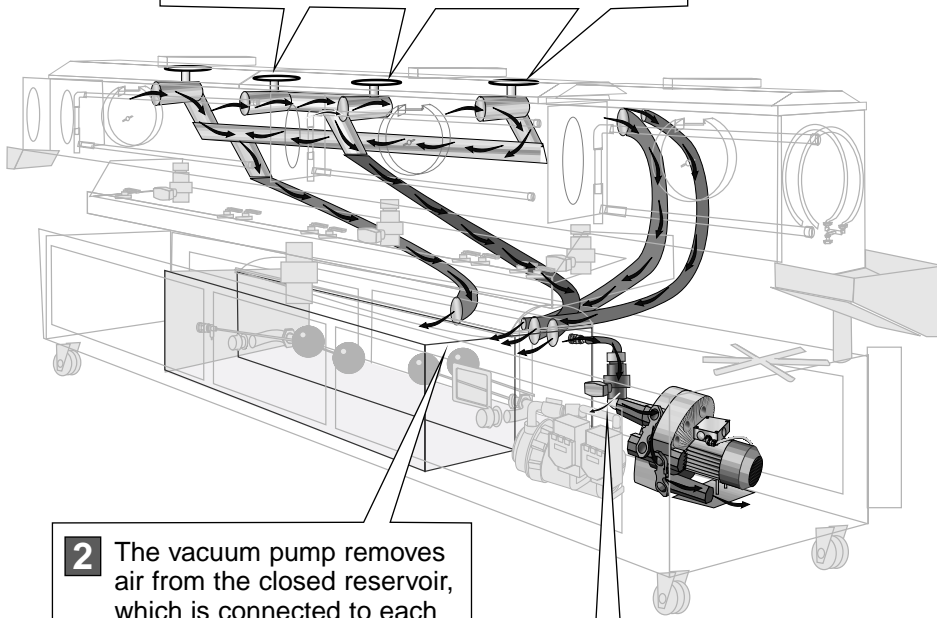

2 The vacuum pump removes air from the closed reservoir, which is connected to each compartment in the sizing tank by 1.5 inch lines.

Coarse Vacuum Adjustment Valve

Opening and closing the 1.5 inch ball valve between the vacuum pump and reservoir provides coarse adjustment of vacuum levels on manual control models only.

If you have a 10-turn potentiometer or PAVC control, the coarse adjustment valve should not be changed from its factory setting.

NOTE: This valve should never be completely closed. It needs to allow the blower to be cooled by some air flow.

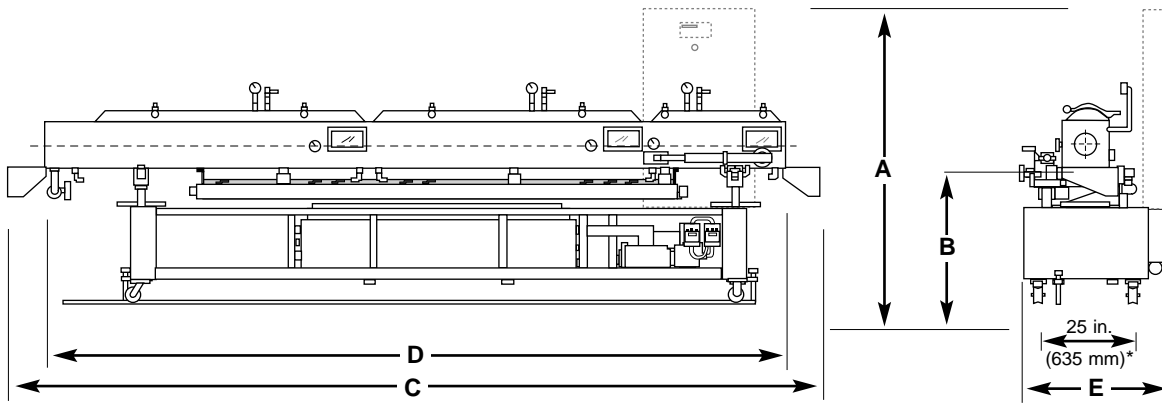

MODEL	MT104					MT105			
TANK STYLE	104-7-2	104-10-3	104-13-3	104-16-4	104-22-5	105-7-2	105-10-3	105-16-4	105-22-5
Performance characteristics									
Tube/profile capacity	up to 2 in. {50 mm}					up to 4.5 in. {125 mm}			
Vacuum blower / Water pump	1.7 Hp vacuum / 2 Hp water					1.7 Hp vacuum / 2 Hp water			
Number of compartments	2	3	3	4	5	2	3	4	5
3 ft. / 6 ft. / 1 ft. seal	0 / 1 / 1	1 / 1 / 1	0 / 2 / 1	1 / 2 / 1	1 / 3 / 1	0 / 1 / 1	1 / 1 / 1	1 / 2 / 1	1 / 3 / 1
Dimensions inches (mm)									
A - Overall height	84 {2134}	84 {2134}	84 {2134}	84 {2134}	84 {2134}	84 {2134}	84 {2134}	84 {2134}	84 {2134}
B - Height to centerline [†]	42 {1067}	42 {1067}	42 {1067}	42 {1067}	42 {1067}	42 {1067}	42 {1067}	42 {1067}	42 {1067}
C - Overall length	108 {2743}	144 {3658}	180 {4572}	216 {5486}	288 {7315}	108 {2743}	180 {4572}	216 {5486}	288 {7315}
D - Tank length feet (mm)	7 {2134}	10 {3048}	13 {3962}	16 {4877}	22 {6705}	7 {2134}	13 {3962}	16 {4877}	22 {6706}
E - Overall width	7 {2134}	48.5 {1232}	48.5 {1232}	48.5 {1232}	48.5 {1232}	48.5 {1232}	48.5 {1232}	48.5 {1232}	48.5 {1232}
Tank compartment width	12 {306}	12 {306}	12 {306}	12 {306}	12 {306}	12 {306}	12 {306}	12 {306}	12 {306}
Tank compartment height	8 {203}	8 {203}	8 {203}	8 {203}	8 {203}	12 {306}	12 {306}	12 {306}	12 {306}
Weight lbs {kg}									
Shipping	1500 {680}	1800 {816}	2200 {998}	2800 {1270}	3500 {1587}	1500 {680}	2200 {998}	2800 {1270}	3500 {1587}
Electrical requirements Full Load Amps [‡]									
240V/3 phase/50-60 Hz	12.9					12.9			
480V/3 phase/50-60 Hz	6.5					6.5			
Water requirements City, tower or chiller water; main supply line 1" NPT fitting									

MODEL	MT107		MT109	
TANK STYLE	107-17-4	107-23-5	109-17-4	109-23-5
Performance characteristics				
Tube/profile capacity	up to 6.625 in. {168 mm}		up to 8.625 in. {219 mm}	
Vacuum blower / Water pump	5 Hp / 2 Hp		5 Hp / 2 Hp	
Number of compartments	4	5	4	5
4 ft. / 6 ft. / 1 ft. seal	1 / 2 / 1	1 / 3 / 1	1 / 2 / 1	1 / 3 / 1
Dimensions inches (mm)				
A - Overall height	84 {2134}	84 {2134}	84 {2134}	84 {2134}
B - Height to centerline [†]	42 {1067}	42 {1067}	42 {1067}	42 {1067}
C - Overall length	228 {5791}	300 {7620}	228 {5791}	300 {7620}
D - Tank length feet (mm)	17 {5182}	23 {7010}	17 {5182}	23 {7010}
E - Overall width	48.5 {1232}	48.5 {1232}	48.5 {1232}	48.5 {1232}
Tank compartment width	14 {356}	14 {356}	16 {406}	16 {406}
Tank compartment height	14 {356}	14 {356}	16 {406}	16 {406}
Weight lbs (kg)				
Shipping	2900 {1315}	3600 {1633}	3000 {1367}	3800 {1724}
Electrical requirements Full Load Amps [‡]				
240V/3 phase/50-60 Hz	12.9		12.9	
480V/3 phase/50-60 Hz	6.5		6.5	
Water requirements City, tower or chiller water; main supply line 1 inch NPT fitting				

SPECIFICATION NOTES:

These tables define standard configurations only. Specifications can change without notice. Contact a Conair representative for the most current information.

* You will need a V-groove caster adapter if you have rails that are not spaced 25 inches {635 mm} apart. Adapters are available for rails with centerline spacing of 22 to 25 inches {559 to 635 mm}.

† Centerline height is adjustable ± 2 inches.

‡ Amp draws will increase for optional pump configurations.

OPTIONS AND LIMITATIONS

Available options:

- **Flow meters** on the water valves in each chamber and on the profile manifold.
- **A 5.1 HP vacuum pump** (150 cfm, not available on all models) for processes that require vacuum pressures up to 200 inches of water (14.7 inches of mercury) and high cfm rates for producing larger tubes and profiles.
- **A 5.0 or 7.5 HP water pump** (not available on all models) for processing thick-walled products or high-speed lines that require greater water flow.
- **A liquid ring vacuum pump** (2.5 or 4.5 Hp) for processes that require vacuum pressures of at least 10 inches of mercury (130 inches of water). These pumps may be used with manual controls only, including the MT tank's profile manifold. These pumps are not recommended for processes using non-contact tooling.
- **A bolt-on air wipe compartment** for drying the plastic product as it leaves the sizing tank. This device requires compressed air supplied at up to 80 psi.
- **Ten Turn Potentiometer Control** including AC inverter and manual vent valve.
- **Precision Automatic Vacuum Controller (PAVC)** upgrade. The PAVC has a built-in transducer and PID to control vacuum level.

Available on models MT104 and MT105:

- **Glass lids** with units that have a 1.7 Hp vacuum pump and maximum vacuum pressure of 135 inches of water. Glass lids may not be used with larger vacuum pumps.
- **Telescoping front drain tray** for catching water running off the calibration tool. The tray expands from 4 inches to 12 inches (102 mm to 305 mm).
- **Flip-up immersion rollers** for holding the plastic product above or below the water in the sizing tank.
- **Independent vacuum control** valving for secondary chamber.

Available on models with 4 to 5 chambers in 16-foot or 22-foot tanks:

- **A dual vacuum system** for processes that require different vacuum levels in the first and subsequent vacuum chambers to size and then maintain the correct shape of the extrudate. The option includes two identical water pumps and two identical vacuum pumps.

INSTALLATION

- *Unpacking the boxes3-2*
- *Preparing for installation3-3*
- *Setting up and aligning the
 MT Tank3-4*
- *Connecting the main power . . .3-5*
- *Connecting the water supply . .3-6*
- *Connecting a chiller3-7*
- *Testing the installation3-8*

UNPACKING THE BOXES

The MT Series Vacuum Sizing Tank comes fully assembled in a single crate.

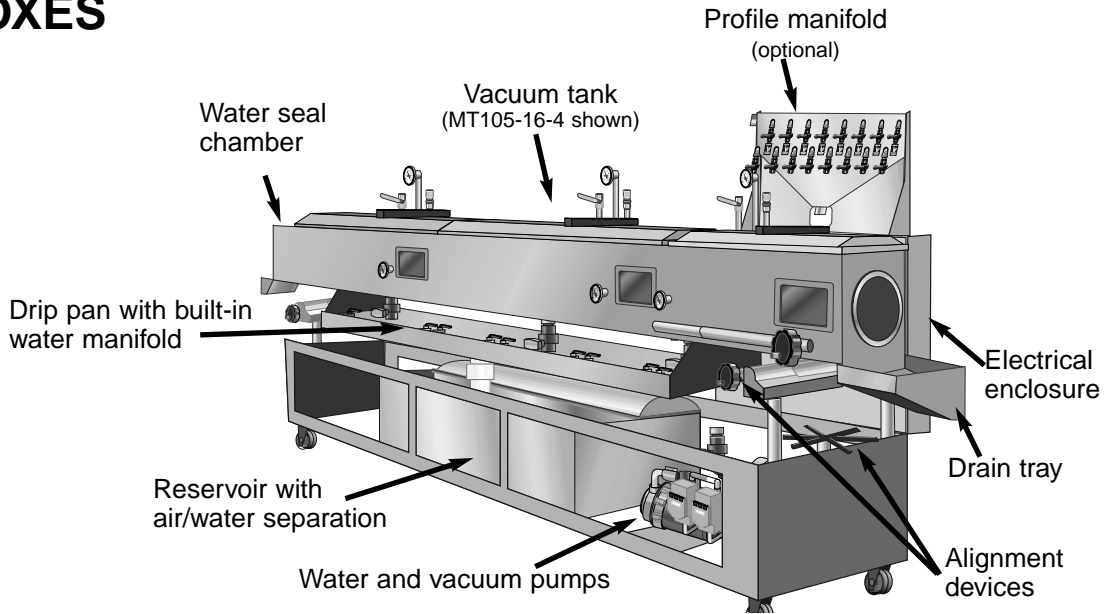

CAUTION: Exercise caution when moving the MT tank. The tank may be lifted with a forklift or hoist and straps that have been positioned at the tank's center of gravity.

- 1 Carefully uncrate the MT tank** and its components.
- 2 Remove all packing material**, protective paper, tape, and plastic. Compare contents to the shipping papers to ensure that you have all the parts.
- 3 Carefully inspect all components** to make sure no damage occurred during shipping. Check all wire terminal connections, bolts, and any other electrical connections, which may have come loose during shipping.
- 4 Take a moment to record serial numbers** and specifications in the blanks provided on the back of the User Guide's title page. The information will be helpful if you ever need service or parts.
- 5 You are now ready to begin installation.** Complete the preparation steps on the next page.

Installation Hardware:

- wire strain relief
- one plumb bob or laser bore sight
- one hex key wrench
- one flathead screwdriver
- flexible hose with 1 inch NPT coupling

You will install the MT tank on the extrusion line, downstream of the extruder.

PREPARING FOR INSTALLATION

1 Make sure the installation area provides:

- A source of water.** City, tower or chilled water may be used.
- A grounded 3-phase power source supplying the correct current and voltage** for your MT tank. Check the serial tag for the correct amps and voltage.
- Minimum clearance for safe operation and maintenance.** The distance, or air gap, between the face of the die and the upstream end of the tank may be up to 12 inches (305 mm). Allow at least 12 to 24 inches (305 to 610 mm) between the downstream end of the tank and the upstream end of the puller to roll the tank away from the extruder for maintenance.

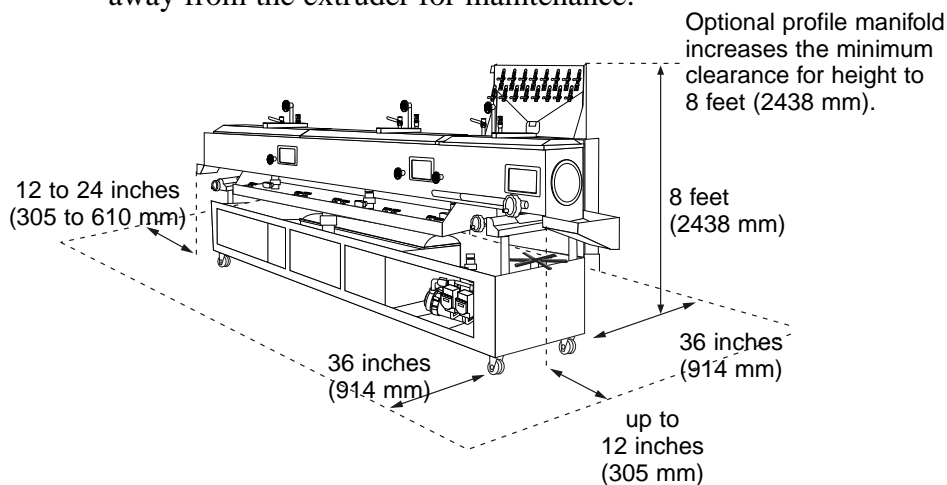

2 Determine the correct position for the MT tank on the extrusion line.

There may be an additional cooling tank or an optional laser gauge/diameter gauge between the downstream end of the MT tank and the puller. Allow 1 to 2 feet (305 to 610 mm) between the MT tank and a cooling tank. Allow 1 to 3 feet (305 to 914 mm) between the MT tank and a laser gauge and between a laser gauge and the puller.

- ### 3 Install v-rails.
- If your tank comes with v-groove casters, you may choose to use v-rails to insure repeatable tank alignment. The overall length of the rails will be determined by equipment sharing the rails. Typically, the rails should be 2 to 4 feet (610 to 1219 mm) longer than the MT tank. The distance between the centers of the v-groove casters on standard MT tanks is 25 inches (635 mm). Optional widths may have been ordered.

NOTE: We recommend installing a grate or drain system below or alongside the tank to prevent water from pooling on the floor around the tank.

SETTING UP AND ALIGNING THE MT TANK



CAUTION: To avoid personal injury or damage to the tank, you should lift and move the tank with a forklift or hoist and straps positioned at the tank's center of gravity.

1 Position the tank downstream of the extruder.

Place the tank inline with the extruder. Set the tank's v-groove casters on the v-rails, if present.

2 Mount the calibration tool.

Loosen and remove the wing nuts on the bolts at the upstream (extruder) end of the tank. Using the bolts and bolt pattern provided, attach the calibration tool inside the first vacuum chamber. Bolt any external tooling or cooling devices to the outside of the first vacuum chamber.

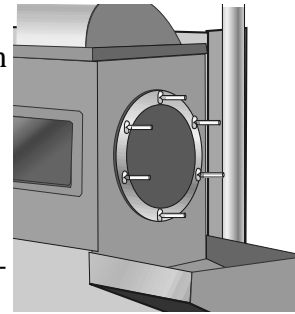

3 Adjust the lateral (side-to-side) position of the MT tank. Use a plumb bob or laser and turn the hand wheel to align the unit with other components in the extrusion line.

4 Adjust the height of the MT tank to match the extruder's centerline height. Use a level and turn the hand wheels to adjust height at both ends of the tank.

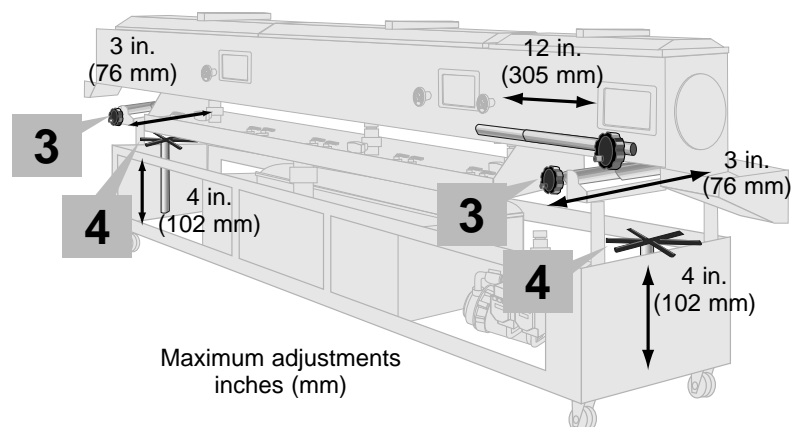



WARNING: Improper installation could result in equipment damage and severe personal injury from electrical shock.

Electrical connections should be made only by qualified personnel. This machine requires a well-grounded circuit and three-phase alternating current as specified on the data plate. If the correct power supply is not available, you must install a transformer between the building supply and the machine. A properly sized conductive ground wire from the power supply must be connected to the ground terminal on the tank.

CONNECTING THE MAIN POWER

- 1 Disconnect and lock out the incoming main power source.**
- 2 Open the MT tank's electrical enclosure.** Turn the disconnect dial to the Off position, turn the captive screw and swing the door open.

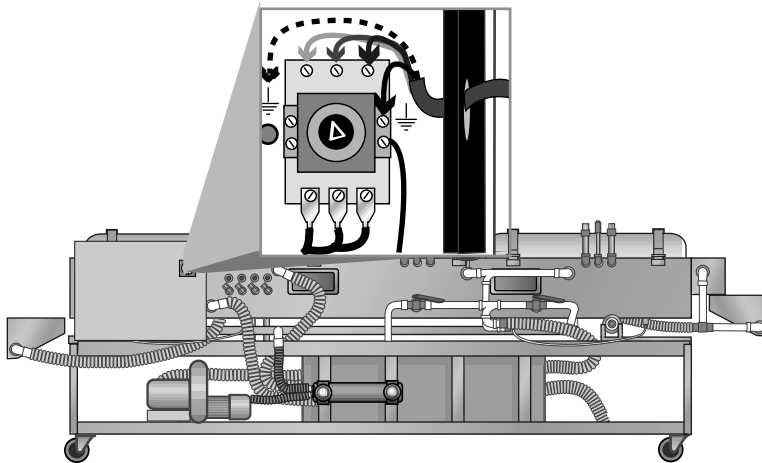

- 3 Drill hole in the side or top of the electrical enclosure near the disconnect switch.**
- 4 Insert the main power wire.** Secure the wire with a rubber compression fitting or strain relief.
- 5 Connect the power and ground wires** to the terminals indicated on the wiring diagram that came with your machine.
- 6 Check every terminal screw** to make sure wires are secure. Gently tug each wire. If a wire is loose, use a screwdriver to tighten the terminal.

IMPORTANT: Always refer to the wiring diagrams that came with your MT Tank before making electrical connections. The diagrams show the minimum size main power cable required for your tank, and the most accurate electrical component information. Have a qualified electrician check the tank's data plate that gives voltage and amperage and make sure it matches your circuitry.

CONNECTING THE WATER SUPPLY

The standard MT tanks are designed for use with city, tower or chilled water supplies. You may choose to treat the water to prevent algae build-up.

⚠ WARNING: Do not use deionized water, brine or other corrosive water mixtures for the main water supply unless your tank has been specially designed for such mixtures. Consult a water treatment specialist for the best way to prevent algae build-up without damaging the equipment.

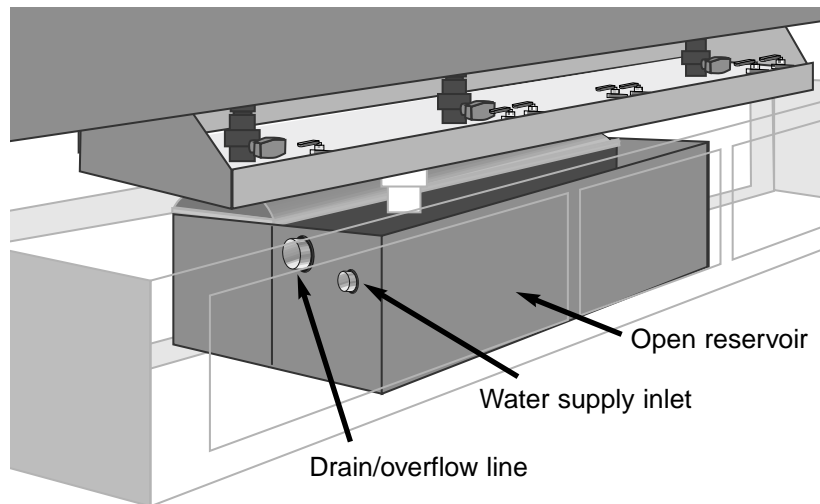

- 1** Connect the main water supply to the 1-inch NPT fitting on the open reservoir.
- 2** Connect hose and NPT fittings to the main 3-inch drain/overflow line. You also may choose to install drain hoses and valves in the bottom of the open and closed reservoirs. Drain holes with plugs have been provided.
- 3** Position the top of each float ball in the reservoirs about 2 to 3 inches below the top rim and make sure screws and nuts are tight.

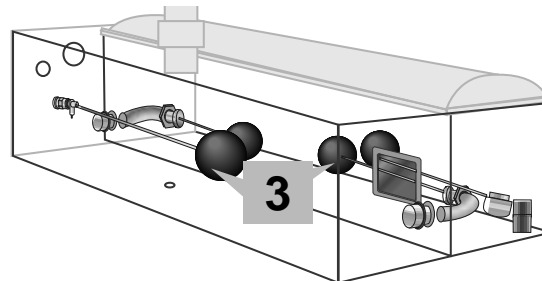

CONNECTING A CHILLER

You can connect a chiller to the tank's heat exchanger to remove heat from the extrudate more efficiently. Typically, the vacuum sizing tank comes with the 1¹/₄ inch tube ends of the plate heat exchanger plumbed to the tank's water manifold and pump. The 1¹/₄ inch inlet and outlet of the heat exchanger can be used for the chiller.

For maximum cooling efficiency: (always plumb cooling water in the opposite direction of process water)

Connect the chiller "To Process" and "From Process" lines to the 1¹/₄ inch NPT fittings on the plate heat exchanger.

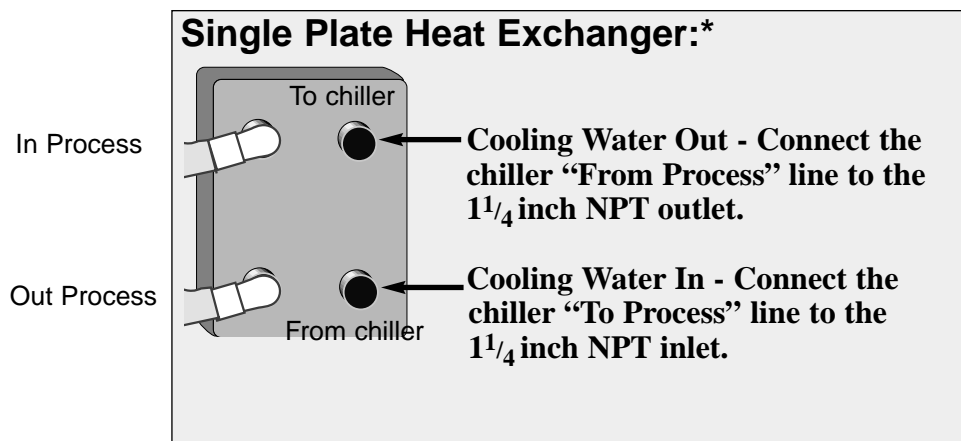

*If your MT Tank is equipped with an optional dual plate heat exchanger the cooling water inlet and outlet are 1¹/₂ inch NPT fittings.

TESTING THE INSTALLATION

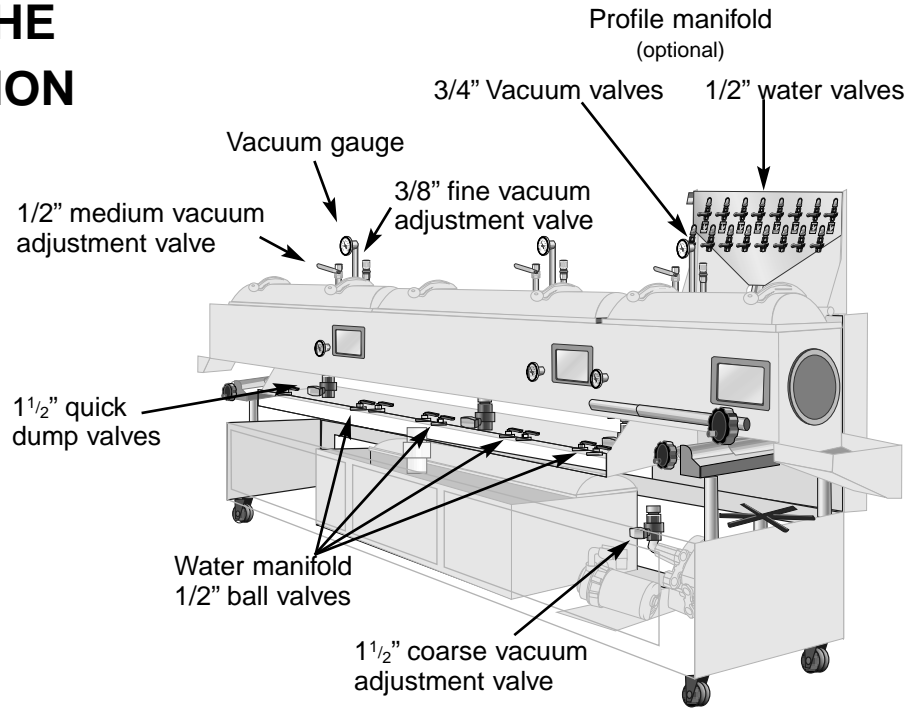

NOTE: The MT tanks with manual controls have medium and fine vacuum adjustment valves. MT tanks with the potentiometer or optional PAVC control do not have these valves. The PAVC or potentiometer is used for medium and fine vacuum adjustment.

1 Turn water supply on and fill the reservoirs.

Make sure the water level in the reservoir is above the pump input before proceeding.

- ◆ Water pours into the reservoir.
- ◆ The floats rise with the water level.
- ◆ When the water level reaches 3-4 inches below the top rim of the reservoir, the float valves close.

2 Open the 1/2 inch water manifold valves one-third.

The valves open fully with one-quarter turn.

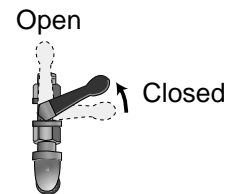

3 Turn water pump on. Press #1 REC START.

If you have a second water pump, press #2 REC START so both pumps are running.

- ◆ The pump draws water from the closed reservoir through the heat exchanger and into the upper tank. If you have the profile water manifold it fills as well.
- ◆ Some water is circulated back to the reservoirs through a bypass valve to prevent cavitation.
- ◆ If you have an optional liquid-ring vacuum pump, some water is diverted to lubricate the pump.



4 Check the pump(s) for proper rotation. If very little water comes out of the sprays bars when the water pump is turned on, the pump is rotating in the wrong direction. Compare the pump rotation to the arrow stamped on the pump housing. If the pump's rotation is incorrect, swap any two of the three power source wires on the terminal block in the electrical enclosure to correct rotation for all pumps. Let the water pump run for two minutes to bleed air from the system. (if no water flows you may need to shut the pump off and remove the bleed plug. When water flows out of the plug hole and no air flows out then replace and tighten the bleed plug.

5 Close the 1½-inch plastic ball dump valves on the bottom of each upper tank chamber to stop any water from draining from the tanks.

6 Close the lids. For a better seal, wet the surface of the lid gasket before closing the tank lid.

7 Open vacuum adjustment valves. If your model has manual controls, open the fine and medium adjustment valves on each chamber. If you have the 10-turn potentiometer or the PAVC control, turn the potentiometer counterclockwise to the zero position. If you have a PAVC control, push the coarse up arrow to open the automatic vent valve.



8 Press the VAC start button to start the vacuum pump. You will hear the vacuum pump come on and will notice the lid pulling down as the vacuum is increased. If you have a PAVC control, push the coarse down arrow to close the automatic vent valve.

TESTING THE INSTALLATION

⚠ WARNING: If a pump rotates in the wrong direction for more than a very short time, damage will occur.

⚠ WARNING: Voltage Always disconnect and lock out the main power sources before making electrical adjustments. Electrical adjustments should be made only by qualified personnel.

NOTE: An electrical interlock prevents the vacuum pump from starting unless the water pump is running.

steps continued on the next page

TESTING THE INSTALLATION

CONTINUED

9 Slowly close vacuum adjustment valves.

If your model has manual controls, close the coarse, fine and medium adjustment valves on each chamber. If you have the 10-turn potentiometer or the PAVC control, control, turn the potentiometer to close the automatic vent valve.

- ◆ If there are no leaks in the system, the vacuum will go to the maximum level of 14.7 inches of mercury or 200 inches of water on units with 5.1 Hp blowers or 9.9 inches of mercury or 135 inches of water on units with a 1.7 Hp blower

IMPORTANT: Do not open or close the 1½-inch coarse adjustment valve on a model with 10-turn potentiometer or PAVC controls. This valve was adjusted at the factory to provide optimum vacuum pump performance.

- ## 10 The test is over.
- If the vacuum sizing tank performed as indicated in the test, you can go to the OPERATION section. If the tank did not perform as indicated, see the TROUBLESHOOTING section of this manual.

OPERATION

- **MT Tank control features4-2**
- **Preparing for operation4-4**
- **Vacuum modes4-5**
- **Cooling modes and immersion rollers4-5**
- **Centering the tank with the extrudate4-6**
- **Threading the extrudate4-7**
- **Starting an MT Tank with manual controls4-8**
- **Starting an MT Tank with a 10-turn potentiometer .4-10**
- **Adjusting water flow4-12**
- **Adjusting water levels4-13**
- **Stopping the MT Tank4-14**

MT TANK CONTROL FEATURES

You will use a number of valves to control water flow and vacuum pressure to the MT vacuum sizing tank.

Each vacuum chamber on a manual control model has a vacuum pressure gauge, a 1/2-inch medium vacuum adjustment valve, and a 3/8-inch fine adjustment valve for independent vacuum control.

If you have an optional 10-turn potentiometer or PAVC control, you don't have these manual valves. You will use the potentiometer for medium and fine adjustment of vacuum levels. The potentiometer changes vacuum levels by controlling an automatic vent valve and vacuum pump rpm.

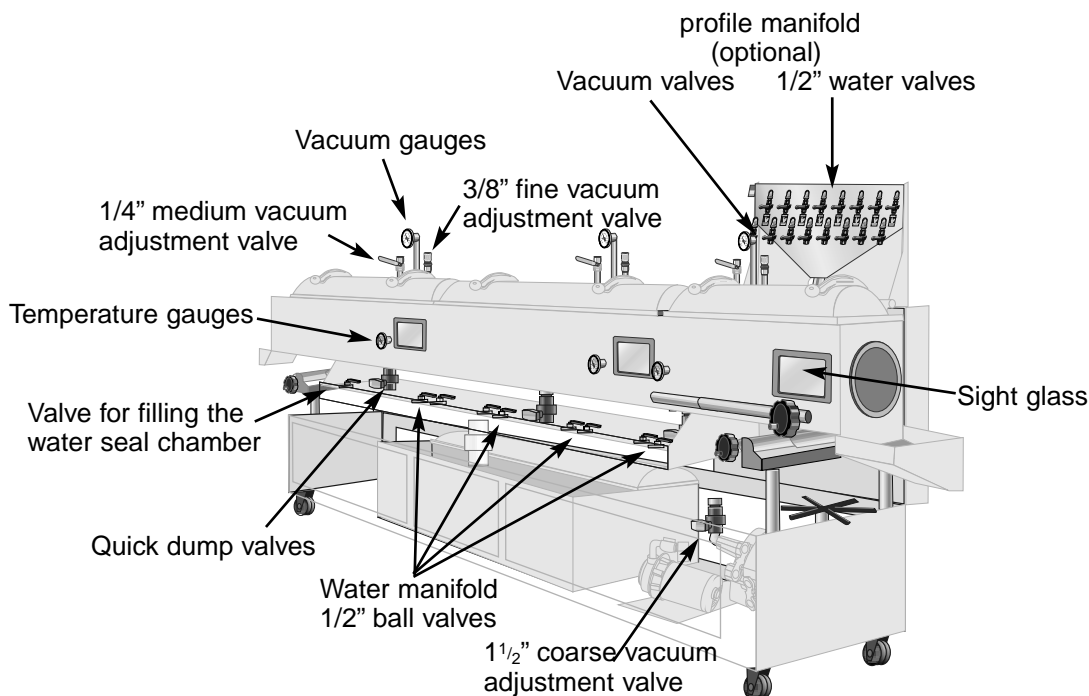

Optional Independent Vacuum Control Valving

A three-way ball valve directs water flow from the second and subsequent chambers to the open or closed reservoir. The three-way ball valve and the 1 1/2-inch course adjustment valve enable you to turn the vacuum pressure to these chambers on or off.

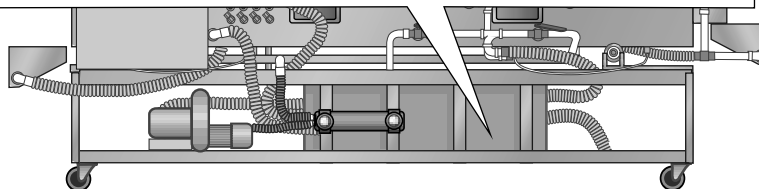
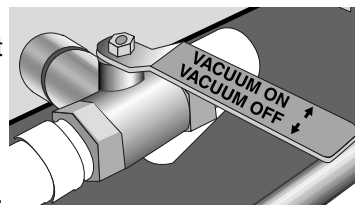

Button positions on the control panel vary depending upon the options selected. The MT may have an additional vacuum pump and control buttons dedicated to the profile manifold. The REC buttons control the water recirculation pump. The VAC buttons control the vacuum pump.

If you purchased an optional dual-water pump system, you will have an additional set of REC start and stop buttons. REC #1 serves the first chamber. REC #2 serves the rest of the tank.

If you purchased an optional dual-vacuum pump system, you will have an additional set of VAC start and stop buttons. You also may have a second 10-turn potentiometer.

MT TANK CONTROL FEATURES

(OPTIONAL 10-TURN
POTENTIOMETER CONTROL)

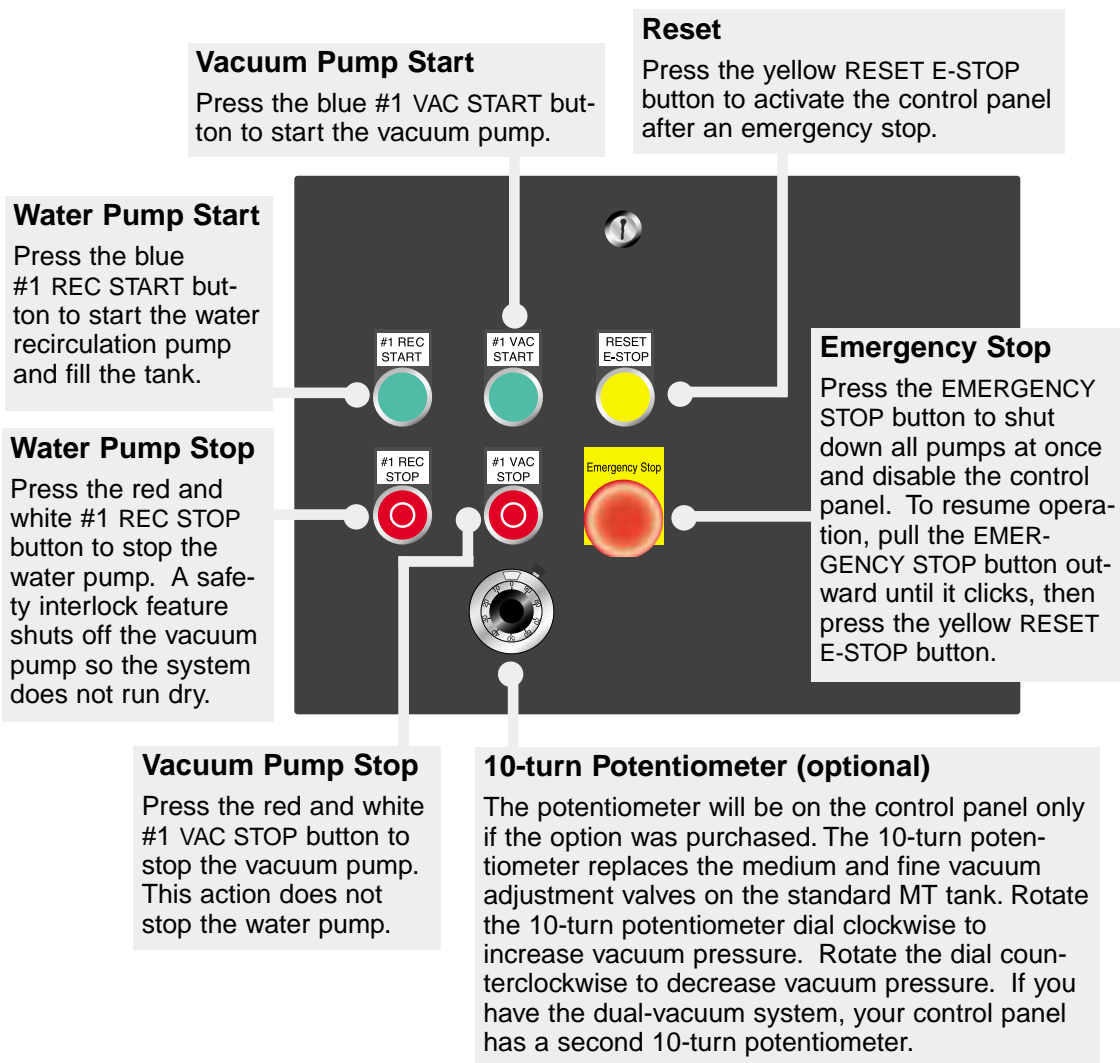

NOTE: If you have an optional Precision Automatic Vacuum Controller (PAVC), see the PAVC User Guide for operating features and instructions. The 10-turn potentiometer also will be present on the PAVC model.

PREPARING FOR OPERATION

After the MT Tank is properly installed, you can prepare for operation. Basic tasks are outlined here. Step-by-step instruction can be found in the rest of the OPERATION section.

1 Determine the vacuum and cooling mode you will use. See *VACUUM MODES* and *COOLING MODES*.

2 Make sure the extruder and puller are ready. The extruder should be discharging melt or extrudate that is up to the correct temperature. Set the extruder and puller at minimum speed, or the speed that makes starting up easiest.

3 Center the tank with the extrudate. During installation, you aligned the tank with the extrusion line. Before each operation of the tank, however, you must fine tune the height and side-to-side position of the tank to align it with the center of the extrudate.

4 Turn on the water supply to fill the reservoirs. Make sure reservoirs are at least half full before proceeding.

- ◆ Two automatic float valves direct water into the open and closed reservoirs.
- ◆ The floats rise until the water level reaches 3-4 inches below the top of the reservoir rim. Then the float valves close.

5 Fill the water and profile manifolds. Open the 1/2-inch manifold valves halfway. Press #1 REC START to turn on the water pump. If you have a second water pump, press #2 REC START so both pumps are running.

- ◆ The pump draws water from the closed reservoir through the heat exchanger and into the upper tank. If your MT Tank has the profile manifold option, the profile manifold fills as well.
- ◆ Some water is circulated back to the reservoirs to prevent cavitation.



6 Thread the extrudate through the tank.

7 Position the immersion rollers to prevent the tube or profile from sinking or floating. Slide each roller up or down to the desired position. The best position for the rollers depends upon your material, process, cooling mode and vacuum mode. Tighten the wing nuts to hold the rollers at the correct height.

VACUUM MODES

The MT vacuum sizing tank provides general vacuum mode operation for hollow tubes and profiles only. The MT sizing with an optional profile manifold enables processing of non-hollow profiles in general, wet-over-dry or dry vacuum mode.

In all vacuum modes, water circulates through the tank. As the puller draws the extrudate through the tank, vacuum pressure keeps the exterior wall of the profile against the calibration tool.

- **General vacuum mode:** The system applies vacuum pressure to the entire chamber around the hollow tube or profile. This creates lower pressure outside the extrudate than inside, so inside pressure pushes the extrudate wall outward against the calibration tool.
- **Wet-over-dry mode:** The calibration tooling is completely submerged. The system applies vacuum pressure directly to the tooling itself, drawing the profile wall outward against the tool. Wet-over-dry mode is useful for non-hollow profiles.
- **Dry mode:** The calibration tooling is not submerged. Instead, a water jacket built into the calibration tool provides initial cooling followed by forced air or a spray mist. As in wet-over-dry mode, vacuum pressure draws the profile wall outward against the tool. Dry vacuum mode is useful for non-hollow profiles that require gradual cooling.

The MT Vacuum Sizing Tank provides cooling through tank water flow, spray bars and optional fogging or atomizing nozzles. Immersion rollers inside each tank chamber keep the profile positioned for even cooling. The best cooling mode and roller position for your profile depends upon your material and process.

COOLING MODES AND IMMERSION ROLLERS

- **Immersion cooling:** The tube or profile should be fully immersed in the tank water. The immersion rollers are usually positioned above the profile to keep it submerged.
- **Spray cooling:** The tube or profile is cooled by water sprayed over its surface. An inch or two of runoff water flows below the profile. The immersion rollers are usually positioned below the profile.
- **Fogging or atomizing:** A very fine water mist cools the tube or profile, providing the greatest rate of heat transfer. The tool is dry and immersion rollers are below the profile.

CENTERING THE TANK WITH THE EXTRUDATE

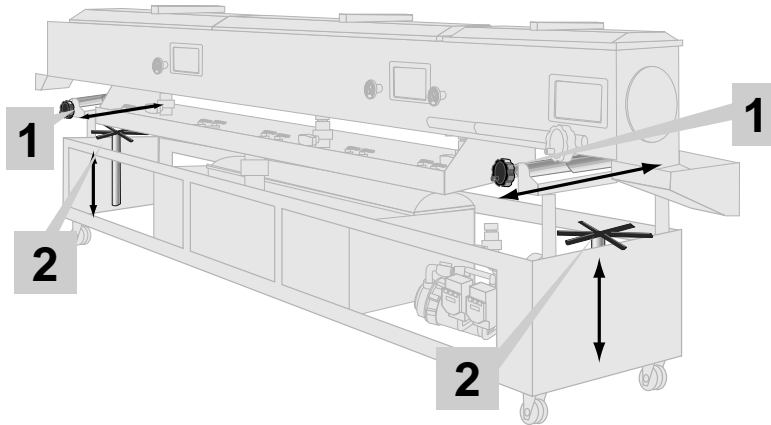

- 1 Adjust the side-to-side tank position.** Looking down from above the tank, turn the small handwheel to move the tank toward or away from the operator side until it aligns with the center of the extrudate as it exits the die. The adjustment rate is 5 turns per inch (25 mm).
- 2 Adjust the tank height.** Kneeling at the upstream end of the tank at eye level with the die, turn the large, spoked wheel to adjust the tank height until it aligns with the center of the extrudate. The adjustment rate is 8 turns per inch (25 mm).

THREADING THE EXTRUDATE

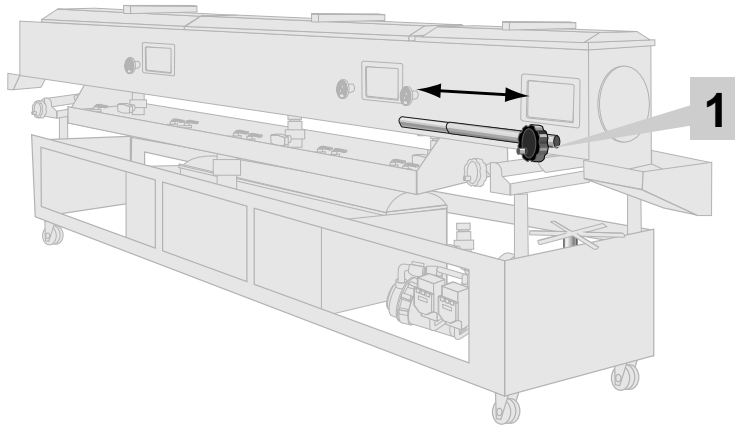

- 1 Move the tank downstream from the die.** Use the large linear actuator handwheel to slide the tank about 4-8 inches downstream from the die. The adjustment rate is 5 turns per inch.
- 2 Cut the extrudate and ball up the end.** Cut the extrudate off close to the die face and ball up the end using a soft-metal spatula or scraper.



CAUTION: Hot surfaces.

Wear gloves to protect yourself from the hot extrudate and hot surfaces on the extruder.

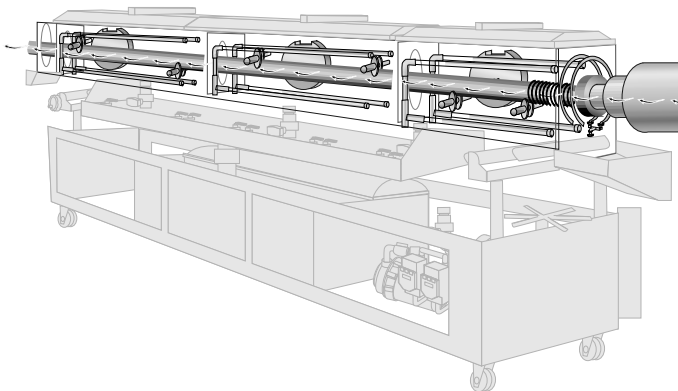

- 3 Walk the extrudate through the system.** Thread the extrudate through the water ring, calibration tool, vacuum tank chambers, tank exit and into the puller.
- 4 Move the tank back upstream for normal operation.** Turn the linear actuator handwheel to move the tank upstream to within 1 inch of the extruder die face.
- 5 Recheck the tank alignment.** With the extrudate threaded, verify that the tank is precisely aligned with the center of the extrudate. If not, go to *Section 4, CENTERING THE TANK WITH THE EXTRUDATE.*

STARTING AN MT TANK WITH MANUAL CONTROLS

Manual motor starters (controls)

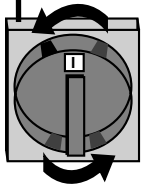
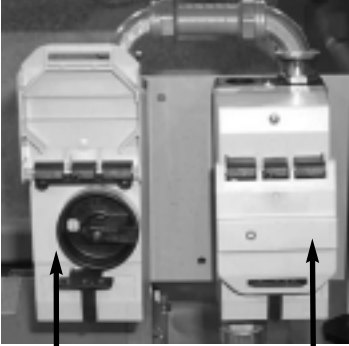

vacuum pump*

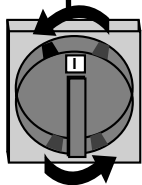

water pump*

*This is the location of the rotary disconnects if tank is right to left configuration. Location of the rotary disconnects is the opposite if tank is left to right configuration.

NOTE: You should check profile size and surface finish at start up and periodically throughout processing. Check the size of the profile using an optional in-line laser gauge, ID or OD gauge. Check the surface finish for imperfections. See the TROUBLESHOOTING section for product quality problems that could be related to the sizing tank.

You can start operating after you have filled the reservoirs and manifolds, turned on the water pump and threaded the extrudate through the tank.

1 Turn the water pump on. Turn the right* rotary disconnect switch to on, or the (I) position for the water pump to start.

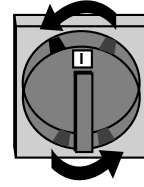

2 Gradually increase line speed. Raise extruder rpms slowly until extrudate is close to the product desired.

3 Open all vacuum valves fully to allow air into the system. Open the 1½-inch coarse vacuum adjustment valve and the medium and fine adjustment vacuum adjustment valves on each chamber. The open valves keep the pressure low to prevent the profile from slamming against the die when the vacuum pump starts.

4 Wet the tank rim lightly and close the lid. Dip fingers into tank water and wet the tank rim to improve the seal. Close the lid. Repeat for each chamber.

5 Turn the vacuum pump on. Turn the rotary disconnect switch on the left* to on, or (I) position for the vacuum pump to start.

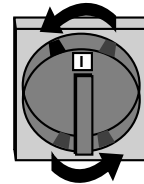

- ◆ The vacuum pump starts.
- ◆ Vacuum pressure gauges display very low vacuum levels because all vacuum valves are open.

6 Adjust vacuum pressure. Start by closing the coarse 1½-inch ball valve until the pressure is within 5 inches mercury of the target pressure. For fine adjustment, use the 1/2-inch and 3/8-inch vacuum adjustment valves.

- ◆ Vacuum gauges reflect a rise in pressure as you close the valves.

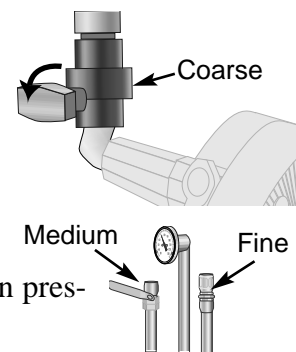

The appropriate vacuum pressure depends upon your material and process. In general, the vacuum pressure is approaching the correct level when the product is close to the desired size, tolerance and surface finish.

steps continued on the next page

7 **Adjust water flow and water levels.** Water flow is controlled by 1/2-inch ball valves in the built-in water manifold and on the optional profile manifold (if included). Each chamber contains a rotary water level control and a quick-dump valve. The best water flow rates and levels depend upon your material, process, cooling and vacuum modes. See *SECTION 4, ADJUSTING WATER FLOW* and *ADJUSTING WATER LEVELS*.

STARTING AN MT TANK WITH MANUAL CONTROLS

STARTING AN MT TANK WITH A 10-TURN POTENTIOMETER (OPTIONAL)

You can start operating after you have filled the reservoirs and manifolds, turned on the water pump and threaded the extrudate through the tank.

- 1 Turn water pump on.** Press #1 REC START. If you have a second water pump, press #2 REC START so both pumps are running.
 - ◆ The pump draws water from the closed reservoir through the heat exchanger and into the upper tank. If you have the profile water manifold it fills as well.
 - ◆ Some water is circulated back to the reservoirs through a bypass valve to prevent cavitation.
 - ◆ If you have an optional liquid-ring vacuum pump, some water is diverted to lubricate the pump.
- 2 Gradually increase line speed.** Raise extruder rpms slowly until extrudate is close to the product desired.

- 3 Set the optional 10-turn potentiometer at zero.** Turn the potentiometer counterclockwise to the zero position. When the vacuum pump comes on, the open valves keep the pressure low to prevent the profile from slamming against the die.

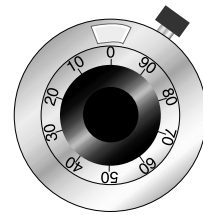

- 4 Wet tank rim lightly and close lid.** Dip fingers into tank water and wet the tank rim to improve the seal. Close the lid. Repeat for each chamber.

- 5 Turn vacuum pump on.** Press #1 VAC START. If you have additional vacuum pumps, press the additional VAC START buttons to start them.
 - ◆ The vacuum pump starts.
 - ◆ Vacuum pressure gauges display very low vacuum levels because bleeder valves are open.

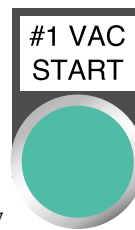

NOTE: The vacuum pump applies pressure to the first chamber automatically when the vacuum pump comes on. If the optional independent vacuum control valving for the secondary chamber has been purchased, you can choose to operate the second and subsequent chambers without vacuum pressure for processes that do not require additional vacuum maintenance. In these cases, the subsequent chambers provide cooling only.

steps continued on the next page

STARTING AN MT TANK WITH A 10-TURN POTENTIOMETER (OPTIONAL)

- 6 Adjust vacuum pressure.** Slowly turn the optional 10-turn potentiometer clockwise. Stop turning the potentiometer when the gauges start to reach the level of vacuum that you want. One turn of the potentiometer changes the vacuum pump power by one hertz, increasing the pump RPMs.
- ◆ Vacuum gauges reflect a rise in pressure as you close the valves.

The appropriate vacuum pressure depends upon your material and process. In general, the vacuum pressure is approaching the correct level when the product is close to the desired size, tolerance and surface finish.

- 7 Adjust water flow and water levels.** Water flow is controlled by 1/2-inch ball valves in the built-in water manifold and on the optional profile manifold (if included). Each chamber contains a rotary water level control and a quick-dump valve. The best water flow rates and levels depend upon your material, process, cooling and vacuum modes. See *SECTION 4, ADJUSTING WATER FLOW* and *ADJUSTING WATER LEVELS*.

ADJUSTING WATER FLOW

Water flow throughout the tank is controlled by 1/2-inch ball valves on the water manifold in the drip tray. The number of valves depends on the number of compartments on your tank. The number of valves in use on the optional profile manifold depends on your calibration tool.

The first upstream ball valve on the manifold adjusts water flow to the vacuum calibration well. The second adjusts water flow to the spray ring in the first chamber. Two additional valves per compartment control water flow to the spray bars.

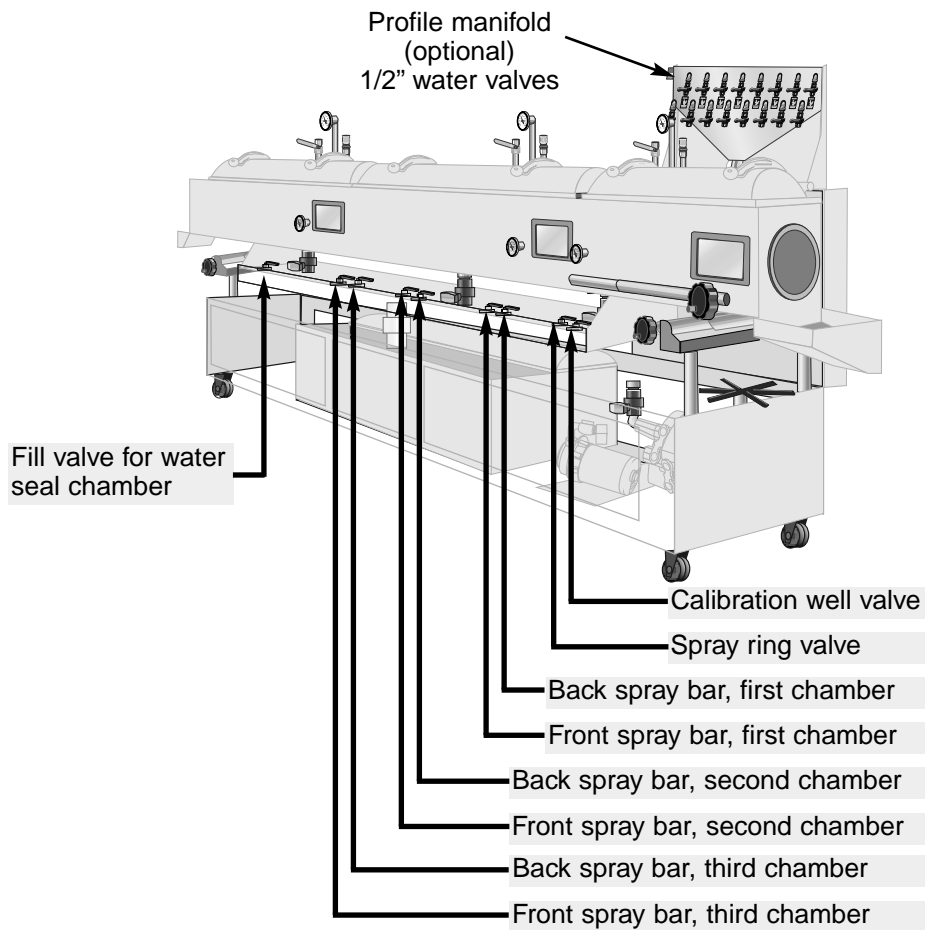

CAUTION: If your system includes a profile manifold with a dedicated vacuum pump, the water level control in the first chamber must be set to keep the water at the lowest possible level, and the 3-way ball valve must direct water back to the closed reservoir to prevent the water pump from running dry. Set the water level control opening facing down and turn the 3-way ball valve counterclockwise until it stops.

Each chamber contains a rotary water level control and a quick-dump valve. The best water level for your application will depend upon your material, process, cooling and vacuum modes.

ADJUSTING WATER LEVELS

To raise or lower the water level:

Loosen the wing nut and manually rotate the water level control until the opening rests at the level you want to maintain. Tighten the wing nut to hold the device in place.

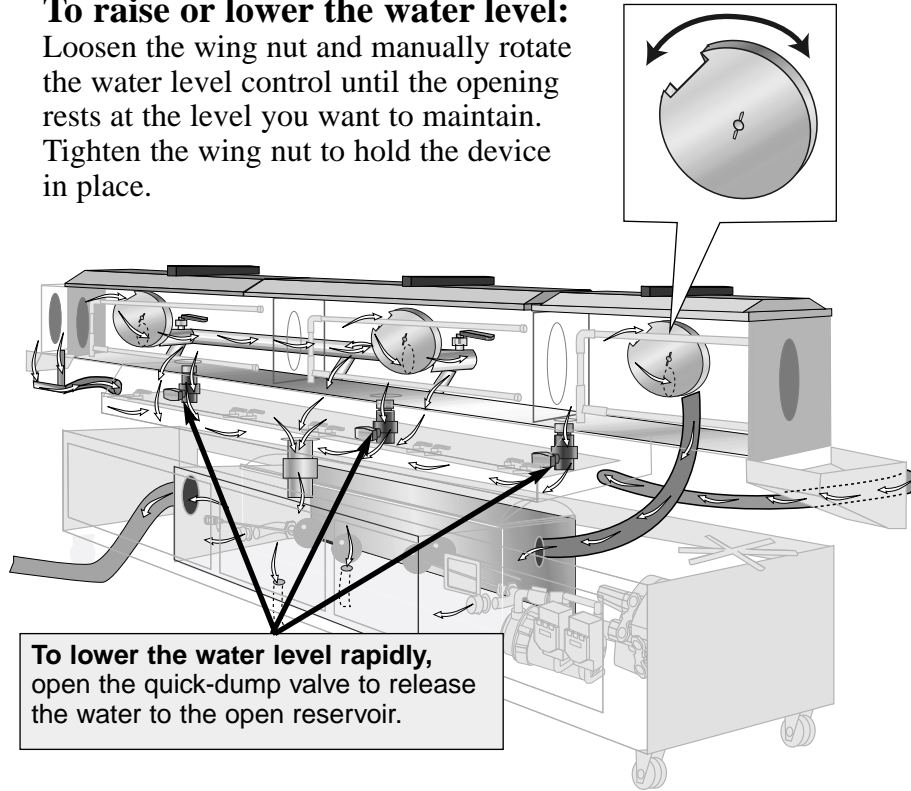

To lower the water level rapidly, open the quick-dump valve to release the water to the open reservoir.

STOPPING THE MT TANK

NOTE: On MT Tanks with the optional 10 turn potentiometer or PAVC controls, the Emergency Stop button on the control panel can be used to stop operation immediately. If the Emergency Stop button is used, you must pull the stop button out and push the reset button to resume operation.

MT Tank operation with manual motor starters (controls) is stopped by turning the rotary disconnect switch for the vacuum pump to the off, or (O) position. Then turn the rotary disconnect for the water pump to the off, or (O) position. MT Tank operation with the optional 10 turn potentiometer or PAVC controls are stopped by pressing the VAC STOP button, then pressing the REC STOP button. Extrudate will continue to move through the tank unless the entire extrusion line is shut down. A typical shutdown procedure is given below.

- 1 Move the tank downstream.** While material is still running, turn the large handwheel to move the tank away from the extruder die.
- 2 Lower extruder rpms.**
- 3 Cut the material off at the die with a soft metal spatula or scraper.**
- 4 If equipped with the optional 3-way ball valve, remove vacuum pressure from the chamber.**
Rotate the 3-way ball valve clockwise until the water flow is diverted from the closed reservoir line to the drip tray and open reservoir.
- 5 Cover the vacuum tank entrance hole** to limit water spillage when you stop the pump.
- 6 Turn the water pump off.**

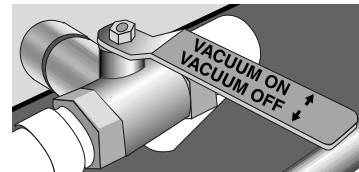

Manual motor starters (controls)

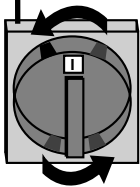
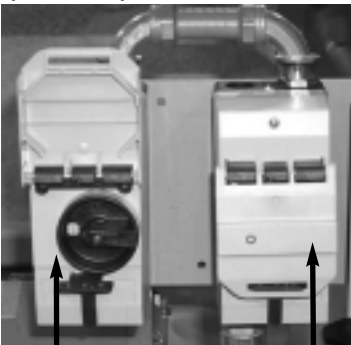

vacuum pump*

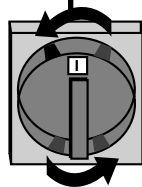

water pump*

*This is the location of the rotary disconnects if tank is right to left configuration. Location of the rotary disconnects is the opposite if tank is left to right configuration.

For MT tanks with the manual motor starters (controls):

Turn the vacuum pump rotary disconnect switch to the off, or (O) position. Then turn the water pump rotary disconnect switch to the off, or (O) position.

For MT Tanks with the optional 10 turn potentiometer or PAVC controls:

Turn the vacuum pump off by pressing the #1 VAC STOP button and then press #1 REC STOP. If you have a dual-water pump system, stop the second pump as well.

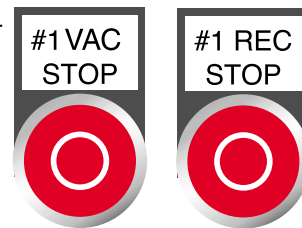

steps continued on the next page

-
- 7** Drain the tank and reservoirs if the tank will not be used or requires water system maintenance. Open the quick-dump valve located in each chamber to drain the tank.

STOPPING THE MT TANK

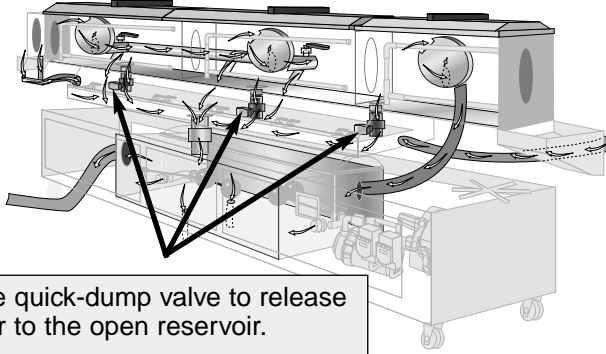

Open the quick-dump valve to release the water to the open reservoir.

MAINTENANCE

- *Preventative maintenance schedule5-2*
- *Inspecting gaskets5-4*
- *Replacing gaskets5-4*
- *Cleaning the filter cartridge5-5*
- *Cleaning the suction screens . .5-5*
- *Lubricating tank components . .5-6*
- *Cleaning the vacuum tank5-6*
- *Cleaning the reservoirs5-7*
- *Cleaning the spray bars5-7*
- *Adjusting the floats5-8*
- *Inspecting electrical connections.5-9*

PREVENTATIVE MAINTENANCE SCHEDULE

Normal operation of the MT tank involves extended exposure of many components to minerals and other water system contaminants. These minerals and contaminants can produce deposits, scales, slime or algae that will reduce sizing tank performance.

To maintain the best performance, you should follow this maintenance schedule and develop an effective water treatment program.

● Daily

Inspect vacuum chamber gaskets.

Gaskets between the vacuum chambers and at the ends of the tank must be in good condition to maintain vacuum stability. Replace any gaskets that are excessively worn, cracked or torn.

● Weekly, or as often as needed.

Clean the coarse suction screens.

Remove the screens from the open reservoir and rinse. Replace if torn or damaged.

Clean the filter cartridge.

Remove the cartridge and rinse. You may need to clean the cartridge more often than weekly, depending upon the quality of your water supply.

Drain and clean the vacuum tank.

Remove any particles and wipe all surfaces thoroughly.

● Monthly

Lubricate all threads, shafts, sliding components, linear actuator and bearings.

Lubricate not only the grease fittings but coat shafts and other sliding surfaces with a seize-resistant bearing compound to prevent corrosion. You may need to lubricate more often than monthly.

Drain and clean the reservoirs.

Remove any particles and wipe all surfaces thoroughly.

Clean the spray bars.

Remove particles and clear any clogs in holes.

Inspect the lid gaskets.

Damaged gaskets decrease vacuum stability. Replace any gaskets that appear torn or cut or do not seal properly.

Check reservoir float adjustment.

Floats should be 2 to 3 inches (51 to 76 mm) below the top of the reservoir rim when fully closed. Tighten any loose screws.

PREVENTATIVE MAINTENANCE SCHEDULE

● Monthly

Clean the plate heat exchanger.

The plate heat exchanger is a sealed unit and can only be cleaned by backflushing. Depending on the quality of your water supply, you may want to backflush the heat exchanger more frequently. Once the unit becomes fouled with deposits, you must replace it.

● Every three months

Lubricate water pump bearing frame, motor and coupling.

Refer to manufacturer's instructions. Recheck pump alignment after performing any maintenance that requires moving the unit.

● Every 6 months

Inspect power cords, wires and electrical connections.

Check for loose wires, burned contacts, and signs of overheated wires. Check exterior power cords to the main power source and from the electrical box to the pumps. Check the ground wire. Replace any wire that appears damaged or has worn or cracked insulation.

● Every 20,000 operating hours or third year

Service the bearing in the liquid-ring vacuum pump.

Refer to manufacturer's instructions for complete details. Recheck pump alignment after any performing maintenance that requires moving the unit.

INSPECTING GASKETS

A tight compartment seal is essential to stable vacuum pressure. Leaks between vacuum chambers, through the lids or at the ends of the tank reduce vacuum pressure stability.

- 1 Drain the upper tank.** Open the quick dump valves located on the bottom of each section of the tank.
- 2 Open the tank compartment lids.**
- 3 Inspect each lid gasket thoroughly for cuts, tears or other damage.**
- 4 Inspect the vacuum chamber gaskets.** Examine the gaskets between chambers and at the ends of the tank for cuts tears or other damage.
- 5 Replace a gasket if you see evidence of damage or notice hissing during operation.**

REPLACING GASKETS

To replace a lid gasket:

- 1 Remove the damaged gasket, and glue a new one in place.** We recommend 3M Scotch Grip #4475 Plastic Adhesive for stainless steel lids or 3M Scotch Grip #4799 Glass Industrial Adhesive for glass lids. Follow the application and curing instructions on the tube of adhesive.

To replace vacuum chamber or end gaskets:

- 1 Remove the retaining rings.** Loosen the wing nuts and lift off the ring that holds the gasket in place.
- 2 Remove the damaged gasket and slide a new gasket over the studs.** No sealant is required.
- 3 Reassemble.** Slip the retaining ring over the studs to cover the gasket. Tighten the wing nuts.

The filter cartridge removes particles from the water before it passes to the vacuum tank. Water contaminants can also leave deposits or algae in the filter. You may need to clean the filter cartridge more often than weekly, depending upon the quality of your supply water.

CLEANING THE FILTER CARTRIDGE

- 1 Remove the cartridge and screen.** Twist the cartridge counterclockwise and pull it out. Lift the filter screen up and out of the cartridge cover.
- 2 Clean the filter screen.** Rinse the filter screen thoroughly using water. Replace the screen if it is damaged or cannot be cleaned.
- 3 Lubricate the cartridge o-ring.** You can use a thin layer of petroleum jelly to help prevent the o-ring from drying and cracking. A slight leak could cause water pump cavitation.
- 4 Reassemble by repeating the steps in reverse order.**

A 2-inch suction screen covers each opening between the open and closed sides of the reservoir. The screens prevent large particles from being drawn into the float valves and the water pump. You may need to clean the suction screen more often than weekly, depending upon the quality of your water supply.

CLEANING THE SUCTION SCREENS

- 1 Inspect and clean the screens.** Wipe each screen with a clean cloth to remove any particles. Check the screen for damage or excessive deposits.
- 2 Remove any damaged or clogged screens.** Rotate the screen counterclockwise and remove it. Rinse it thoroughly. If you cannot unclog the screen or it is damaged, replace it.
- 3 Return the screens to the valve fittings.** Make sure the screens fit securely over the openings. Tighten the screen by hand.

LUBRICATING THE TANK COMPONENTS

Tools required:

- grease gun
- seize-resistant bearing compound

Normal operation of the MT tank creates many wet surfaces. We recommend generous monthly lubrication of any threaded or sliding components involved in positioning the tank. Those components include the positioning mechanisms such as the up/down vertical support shafts, side-to-side cross thread, and the linear actuator. You may need to lubricate more often than monthly.

- 1** **Locate the vertical support shaft grease fittings.**
- 2** **Lubricate the shafts and fittings.** Apply bearing compound to the fittings until it overflows. Apply a coating of the compound to the shafts as well.
- 3** **Lubricate threads and fittings.** Apply bearing compound to the fittings until it overflows. Apply a coating of the compound to the thread as well.
- 4** **Lubricate the linear actuator according to manufacturer's instructions.**

CLEANING THE VACUUM TANK

The vacuum tank chambers should be thoroughly cleaned weekly to remove particles that can accumulate.

- 1** **Drain the tank.** Open the quick-dump valves in each chamber to release water to the drip pan and open reservoir.
- 2** **Clean the tank.** Remove particles from the tank chambers and wipe thoroughly.
- 3** **Check the quick-dump valves for any signs of leakage.** Scratches or other damage can cause vacuum leaks.
- 4** **Close all quick-dump valves.**

The open and closed reservoirs should be drained and cleaned monthly to remove bits of plastic, garbage and other residue.

- 1 Drain the reservoir.** Remove the drain plugs in the bottom of the reservoirs and allow the water to run out. If you have installed drain valves in the bottom of the reservoirs, open the valves fully.
- 2 Clean the reservoir.** Remove any particles and wipe thoroughly.
- 3 Close drains.** Make sure you refill the reservoirs completely from the water supply before turning the pumps back on.

CLEANING THE VACUUM TANK AND RESERVOIRS

Each tank chamber contains spray bars that can become clogged with residue. Clean the spray bars monthly.

- 1 Open the chamber lid.**
- 2 Remove the spray bars.** Twist each spray bar counterclockwise and pull it out.
- 3 Clean the spray bars.** Flush each bar with water. Use a soft brush to remove any particles clogging the small holes.
- 4 Reassemble by repeating the steps in reverse order.**
- 5 Repeat the procedure for each chamber.**

CLEANING THE SPRAY BARS

ADJUSTING THE FLOATS

Tools required:

☐ a 1/4 inch slotted screwdriver

Floation valves maintain the proper water level in the reservoirs. Over time, the screw that holds the float in place may become loose allowing the float position to change. Check the screws and float positions monthly.

The number of floats in your system depends upon your pump configuration. For clarity, we identify floats by location and size.

1 **Inspect the position of the 1-inch float in the open reservoir.** When the valve is closed, the water level should be at least 2 inches above the top of the 2-inch suction screens to prevent cavitation. If necessary, loosen the tiny screw at the base of the float arm. Reposition the float properly, then tighten the screw.

2 **Remove the closed reservoir lid.**

3 **Inspect the position of the 1-inch float in the closed reservoir.** When the valve is closed, the bottom of the float ball should be 6 inches from the bottom of the reservoir. If necessary, loosen the tiny screw at the base of the float arm. Reposition the float properly, then tighten the screw.

4 **Inspect the position of the 2-inch float in the closed reservoir.** When the valve is closed, the top of the 8-inch float ball should be 3 inches down from the top of the reservoir rim. If necessary, loosen the tiny screw at the base of the float arm. Reposition the float properly, then tighten the screw.

5 **Replace closed reservoir lid.**



WARNING: High voltage

This equipment is powered by three-phase main voltage. Always disconnect and lock out the main power source before opening the unit or servicing.

CHECKING ELECTRICAL CONNECTIONS

Normal operation of the MT Tank produces many wet surfaces. We recommend that you carefully check all electrical wires for signs of damage that could result in a serious shock.

1 Stop the MT Vacuum Sizing Tank.

For MT Tanks with the manual motor starters (controls): Turn the vacuum pump rotary disconnect switch to the off, or (O) position, then turn the water pump rotary disconnect switch to the off, or (O) position.

For MT tanks with the optional 10 turn potentiometer or PAVC controls: Press the VAC STOP button then the REC STOP button(s) on the control.

2 Disconnect and lock out the main power source. Turn the disconnect dial on the electrical enclosure to the O or off position.

3 Open the electrical enclosure. A safety device prevents you from opening the door unless the power is shut down. (on tanks with the optional 10 turn potentiometer or PAVC controls.)

4 Inspect the wires and connections. Look for loose wires, burned contacts, and signs of over-heated wires. Have a qualified electrician make any repairs or replacements necessary.

5 Close the electrical enclosure door.

6 Inspect the exterior power cords. Carefully check the power cords from the electrical enclosure to the pumps. Cords should not be crimped, exposed or rubbing against the frame. Also check the power cord to the machine. If the main power cord runs along the floor, make sure it is not positioned where it could rest in pooling water or could be run over and cut by wheels or casters.

TROUBLESHOOTING

- *Before beginning*6-2
- *A few words of caution*6-2

DIAGNOSTICS

- *How to identify the cause of a problem*6-3
- *Water system problems*6-4
- *Vacuum system problems*6-6
- *Electrical problems*6-9
- *Product quality problems*6-9

REPAIR

- *Checking electrical connections*6-10
- *Checking and resetting motor starters*6-12
- *Checking and replacing the 10-turn potentiometer* . .6-12
- *Cleaning the optional automatic vent valve*6-13

BEFORE BEGINNING

You can avoid most problems by following the recommended installation, operation and maintenance procedures outlined in this User Guide. If you do have a problem, this section will help you determine what caused it and tell you how to fix it.

Before you begin troubleshooting:

Find the wiring, plumbing and assembly diagrams that were shipped with your equipment.

These diagrams are the best reference for correcting a problem. The diagrams also will note any custom features, such as special wiring, control or plumbing options, not covered in this User Guide.

Verify that you have all instructional materials related to the MT tank.

Additional details about troubleshooting and repairing specific components of the tank, including pumps, heat exchanger and motor drives, can be found in the manufacturers manuals included in this instruction packet.

Verify that you have manuals for other equipment located on the extrusion line.

Solving problems related to extrudate quality may require troubleshooting malfunctions or incorrect operating procedures on other pieces of equipment in the extrusion line.

A FEW WORDS OF CAUTION



WARNING: This machine should be adjusted and serviced only by qualified technical personnel who are familiar with construction and operation of this type of equipment.



DANGER: Voltage hazard.

Troubleshooting the electrical system of this equipment requires use of precision electronic measuring equipment, as well as access to the electrical enclosure while power is on. Exposure to potentially fatal voltage levels is unavoidable. These troubleshooting procedures should be performed only by qualified electrical technicians who know how to use this precision electronic equipment and who understand the hazards involved.

The TROUBLESHOOTING section has been divided into:

☐ **MT Tank Operation Problems**, which focuses on problems that are clearly related to the operation of the water, vacuum or electrical/control systems of the sizing tank.

☐ **Plastic Product Quality Concerns**, which deals with product characteristics that **may** be related to the MT tank operation. Of course, other sections of the extrusion line also influence the quality of the extruded product. This section does not provide solutions to problems that originate with other equipment on the extrusion line.

Additional troubleshooting help can be found in manuals supplied by manufacturers of tank components and included in this instruction package.

HOW TO IDENTIFY THE CAUSE OF A PROBLEM

WATER SYSTEM PROBLEMS



WARNING: High voltage This equipment is powered by three-phase main voltage. Always disconnect and lock out the main power source before opening the unit for servicing. Only qualified electrical technicians should perform tests that require electrical power to be on.

Problem	Possible cause	Solution
The water pump will not start.	Is the correct power reaching the pump?	<ul style="list-style-type: none"> <input type="checkbox"/> Check all connections and voltages. See Checking Electrical Connections. <input type="checkbox"/> Make sure the emergency stop is disabled. If necessary, pull out the Emergency Stop button, then press the Reset button on the control panel.
	Has the pump motor overload tripped?	Check the trip indicator on the pump overload module. If necessary, manually reset the overload. Verify the overload is set to 125% of the full load amps specified on the motor data plate. See Checking and Resetting Motor Starters .
	Is the pump damaged?	If the correct power is reaching the pump but it does not run, refer to the pump instructions found in the <i>APPENDIX</i> .
There is no or low water flow, even though the pump is running.	Is the pump rotating in the wrong direction?	If the pump is turning opposite the arrow stamped on its housing, turn off and lock out the main power supply. Open the electrical enclosure door, and reverse any two leads connecting the main power to the vacuum sizing tank.
	Is the path of the water flow blocked?	Locate the blockage: <ul style="list-style-type: none"> <input type="checkbox"/> Check the filter cartridge and suction screens. See Cleaning the Filter Cartridge and Cleaning the Suction Screens. <input type="checkbox"/> Check water piping and the heat exchanger for blockages. Clean or backflush, as needed. <input type="checkbox"/> Check for a restriction in the spray bars. Clean, if necessary.



WARNING: High voltage This equipment is powered by three-phase main voltage. Always disconnect and lock out the main power source before opening the unit for servicing. Only qualified electrical technicians should perform tests that require electrical power to be on.

WATER SYSTEM PROBLEMS

Problem	Possible cause	Solution
There is no or low water flow, even though the pump is running. <i>(continued)</i>	Is the makeup water supply on?	The system may have run dry. Check the water level in the open reservoir. Make sure the makeup water supply is on.
The closed reservoir is flooding.	Are the float valves set incorrectly?	Drain the closed reservoir until the water level is normal, or about half full. Check the position of the 8-inch and 4-inch floats. Readjust the float position to make sure the closed reservoir remains about half full.
	Are the float valves working correctly?	Drain the closed reservoir until the water level is normal, or about half full. Verify that each float valve turns on when the float drops below the level at which it was set. The valve should turn off when water raises the float to the level at which it was set. If a float valve is not working properly, replace the valve.

VACUUM SYSTEM PROBLEMS



WARNING: High voltage This equipment is powered by three-phase main voltage. Always disconnect and lock out the main power source before opening the unit for servicing. Only qualified electrical technicians should perform tests that require electrical power to be on.

Problem	Possible cause	Solution
Vacuum pump will not start.	Is the water pump off?	A safety interlock prevents the vacuum pump from starting if the water pump is off. Turn on the water pump.
	Is the correct power reaching the vacuum pump?	<input type="checkbox"/> Check all connections and voltages. See Checking Electrical Connections . <input type="checkbox"/> Make sure the emergency stop is disabled. If necessary, pull out the Emergency Stop button, then press the Reset button on the control panel.
	Did the overload to the AC frequency controller trip? (10-turn potentiometer and PAVC models only)	Check the frequency controller overload and fault indicators. Refer to the frequency controller manual in the <i>APPENDIX</i> .
	Is the vacuum pump damaged?	If the correct power is reaching the pump but it does not run, refer to the pump instructions in the <i>APPENDIX</i> .
The vacuum pump is running, but there is no vacuum.	Is the pump rotating in the wrong direction?	If all pumps are turning opposite the arrows stamped on their housings, turn off and lock out the main power supply. Open the electrical enclosure door, and reverse any two leads connecting the main power source to the tank. If only one pump is rotating the wrong direction, turn off and lock out the main power supply. Then reverse any two leads connecting the pump to the power supply.
	Is the optional 10-turn potentiometer working properly?	See Checking and Replacing the 10-turn Potentiometer .
	Is the AC frequency controller working properly? (units with optional 10-turn potentiometer and PAVC models only.)	Check the frequency controller fault indicators. Refer to the frequency controller manual in the <i>APPENDIX</i> .



WARNING: High voltage This equipment is powered by three-phase main voltage. Always disconnect and lock out the main power source before opening the unit for servicing. Only qualified electrical technicians should perform tests that require electrical power to be on.

VACUUM SYSTEM PROBLEMS

Problem	Possible cause	Solution
Vacuum pump is running, but cannot attain the desired vacuum level.	Is there a leak in the vacuum system?	<ul style="list-style-type: none"><input type="checkbox"/> Verify that all lids, including the lid on the closed reservoir, are seated correctly to allow for a seal.<input type="checkbox"/> Check for holes or tears in all gaskets. Replace any damaged gaskets.<input type="checkbox"/> Make sure the gross bleeder valve on the vacuum pump has not been opened.
	Are the correct valves or devices being used to adjust the vacuum level?	<p>For manual controls only: Make sure you use the coarse adjustment valve (1½" ball valve) to bring the vacuum into the proper operating range. Use the medium and fine adjustment valves to make only small changes in vacuum level.</p> <p>For 10-turn potentiometer only: Make sure the coarse adjustment valve has not been adjusted. This valve has been set at the factory to the correct position. Use only the 10-turn potentiometer to adjust vacuum levels.</p>
	Is the automatic vent valve working properly? (10-turn potentiometer and PAVC models only.)	The automatic vent valve may be dirty or stuck open. Remove it and clean it. See Cleaning the Automatic Vent Valve .
	Is the AC frequency controller set up properly? (10-turn potentiometer and PAVC models only.)	Verify that the Hz or pump RPMs increase as you increase vacuum. If they do not, verify that the drive parameters for the AC frequency controller are correct. See the frequency controller manual and the default parameter tables in the <i>Appendix</i> .

VACUUM SYSTEM PROBLEMS



WARNING: High voltage This equipment is powered by three-phase main voltage. Always disconnect and lock out the main power source before opening the unit or servicing. Only qualified electrical technicians should perform tests that require electrical power to be on.

Problem	Possible cause	Solution
The vacuum level has been attained, but it fluctuates.	Is there a leaking gasket?	Check the gaskets between chamber, on the chamber lids and on the closed reservoir lid. Replace any gasket that is defective.
	Is water trapped in the water return line overflow?	Straighten any loops in the hose. Clear water from other trap areas.
	Is water coming out of the vacuum pump?	The closed reservoir water level is too high. Reposition the float valves. If the problem persists, check for a malfunctioning float valve.
	Is the vacuum pump running smoothly?	If the pump is not running smoothly, refer to the pump manual in the <i>Appendix</i> .
	Are there any loose fittings or bushings?	Check for loose fittings or bushings on the tank, including the vacuum adjustment valves on manual control models. Loose fittings and bushings can cause vacuum instability.
	Is there water in the 6mm line between the closed reservoir and the PAVC? (PAVC control models only)	Disconnect and lockout the power supply before opening the control enclosure. Check the blue hose from the closed reservoir to the PAVC. Straighten any kinks in the line. Make sure the line is not leaking. Check for water in the line. If you find water, clean it out by blowing in the PAVC side of the line.



WARNING: High voltage This equipment is powered by three-phase main voltage. Always disconnect and lock out the main power source before opening the unit for servicing. Only qualified electrical technicians should perform tests that require electrical power to be on.

ELECTRICAL PROBLEMS

Problem	Possible cause	Solution
Pump turns on, but won't stay on.	Has the overload tripped?	See Checking and Resetting Motor Starters .
	Is the pump overheating?	Check power, amps and connections to the pump. If you have a PAVC control, also check the drive parameters.

This section contains product quality problems that may be related to MT tank operation. This section does not provide solutions to product quality problems that originate with other equipment on the extrusion line.

PRODUCT QUALITY PROBLEMS

Problem	Possible cause	Solution
Outside dimensions of the extruded product are wrong.	Has the vacuum level drifted?	Check the vacuum level. Adjust as necessary. See Vacuum System Problems if the desired vacuum level cannot be maintained.
Poor surface quality: chatter marks	Is the vacuum level too high?	If the vacuum level is too high, die swell can occur leading to chatter marks.
Poor surface quality: swirls on the surface.	Is the water well pressure too high?	Reduce the water well pressure.
	Is the extrudate rubbing or dragging against the calibration tool?	Check alignment.
Poor surface quality: dimples on the surface	Are air bubbles adhering to the extrudate surface, causing uneven cooling?	<input type="checkbox"/> Increase spray ring flow. <input type="checkbox"/> Increase agitation in the first chamber. <input type="checkbox"/> Add mineral or baby oil at the water well. <input type="checkbox"/> Add an anti-static agent to the water. <input type="checkbox"/> Add non-sudsing soapy water at the water well.

CHECKING ELECTRICAL CONNECTIONS



DANGER: Voltage hazard.

Troubleshooting the electrical system of this equipment requires use of precision electronic measuring equipment, as well as access to the electrical enclosure while power is on. Exposure to potentially fatal voltage levels is unavoidable. These troubleshooting procedures should be performed only by qualified electrical technicians who know how to use this precision electronic equipment and who understand the hazards involved.



DANGER: Shock hazard.

Make sure that a properly-sized ground wire runs from the incoming power supply to the chassis ground terminal in the electrical enclosure.



IMPORTANT: Always refer to the wiring diagrams that came with your unit to locate specific electrical components. Illustrations in the User Guide are intended to be representative only.

There are several types of problems that may be present within the electrical system: improper grounding; loose connections, incorrect voltages, and defective components. This procedure addresses the first three. Defective components are usually identified by a process of elimination, followed by testing of the suspect component.

Loose connections

- 1** **Disconnect and lockout power.**
- 2** **Reattach and tighten all electrical connections.**
- 3** **Verify the electrical disconnect switch is turned on.**
- 4** **Check fuses and breakers in the disconnect.**
Replace or reset as required. Identify the cause of the ground fault and correct it.

Incorrect voltages

- 1** Verify that the voltage of the incoming power supply at the disconnect matches the voltage specified on the nameplate.
- 2** Verify 110VAC at the input and 12VDC at the output of the DC power supply.
- 3** Verify line voltages at T1, T2, and T3 of the pump motor starter. If the expected voltage is not present, check for defective components or loose electrical connections.

CHECKING ELECTRICAL CONNECTIONS

CHECKING AND RESETTING MOTOR STARTERS

The pump motor starters are located in the electrical enclosure. If the motor starter overload has tripped, the dial will be pointing to the O or off position.

To reset the motor starter:

- 1 Disconnect and lockout the main power source.**
- 2 Open the electrical enclosure.**
- 3 Locate the motor starter.**
- 4 Turn the dial to the I or on position.**
- 5 Close the electrical enclosure.**

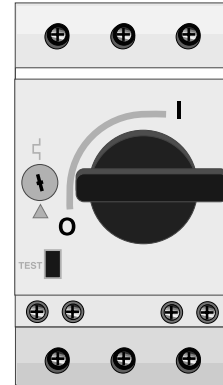

CHECKING AND REPLACING THE 10-TURN POTENTIOMETER (OPTIONAL)



IMPORTANT: Always refer to the wiring diagrams that came with your unit to locate specific electrical components. Illustrations in the User Guide are intended to be representative only.

The 10-turn potentiometer controls both the vacuum pump speed and the position of the automatic vent valve. If you turn the pot and the pump speed does not increase or decrease, something may be wrong with the pot.

- 1 Check the voltage entering the pot.** It should be 10V.
- 2 Check voltage exiting the pot.** It should be between 0 and 10V, and should vary as the pot is turned.

If the incoming voltage is correct but the pot does not produce an exit voltage with values between 0 and 10V, the pot should be replaced. Contact Conair Service.

The optional automatic vent valve controls the vacuum by regulating the amount of air that is allowed to enter (leak into) the vacuum system. It consists of a movable metal disc with a teardrop-shaped opening inside a plastic body. As the disc rotates, the size of the opening changes and more or less air is allowed to enter the system. A small motor (controlled by the 10-turn potentiometer) controls the position of the disc.

As air flows through the automatic vent valve, dust and contaminants may collect in it and cause sticking or stalling. The automatic vent valve assembly (the automatic vent valve, the motor, and a mounting bracket) can be removed from the electrical enclosure for cleaning.

- 1** **Locate the automatic vent valve assembly in the electrical enclosure.**
- 2** **Disconnect the bleed line and unplug the electrical wires from the connectors on the valve assembly.**
- 3** **Remove the valve assembly from the electrical enclosure** by removing two nylon insert nuts and washers that attach the mounting bracket to the electrical enclosure.
- 4** **Open the valve assembly and remove the mounting bracket by removing four hex screws near the vacuum line fitting.**
- 5** **If necessary, remove the metal disc.** It is held to the gear box shaft by a set screw. Loosen the set screw just enough to allow the shaft to slide out. If necessary, use a 12VDC supply to power the valve motor to bring the screw head into an accessible position.
- 6** **Clean plastic and metal parts.** If necessary, use isopropanol (rubbing alcohol) to remove dirt and debris.
- 7** **Reverse the procedure to reassemble the valve and replace it in the electrical enclosure.**

If the valve was not dirty, or the valve still doesn't work after cleaning, the motor/gear box has probably failed. Contact Conair Service.

CLEANING THE OPTIONAL AUTOMATIC VENT VALVE



WARNING: Lockout and disconnect the main power source before troubleshooting or performing repairs.

Conair has made the largest investment in customer support in the plastics industry. Our service experts are available to help with any problem you might have installing and operating your equipment. Your Conair sales representative also can help analyze the nature of your problem, assuring that it did not result from misapplication or improper use.

WE'RE HERE TO HELP

To contact Customer Service personnel, call:



HOW TO CONTACT CUSTOMER SERVICE

From outside the United States, call: 814-437-6861

You can commission Conair service personnel to provide on-site service by contacting the Customer Service Department. Standard rates include an on-site hourly rate, with a one-day minimum plus expenses.

If you do have a problem, please complete the following checklist before calling Conair:

- Make sure you have all model, serial and parts list numbers for your particular equipment. Service personnel will need this information to assist you.
- Make sure power is supplied to the equipment.
- Make sure that all connectors and wires within and between control systems and related components have been installed correctly.
- Check the troubleshooting guide of this manual for a solution.
- Thoroughly examine the instruction manual(s) for associated equipment, especially controls. Each manual may have its own troubleshooting guide to help you.
- Check that the equipment has been operated as described in this manual.
- Check accompanying schematic drawings for information on special considerations.

BEFORE YOU CALL ...

Additional manuals and prints for your Conair equipment may be ordered through the Customer Service or Parts Departments for a nominal fee.

EQUIPMENT GUARANTEE

Conair guarantees the machinery and equipment on this order, for a period as defined in the quotation from date of shipment, against defects in material and workmanship under the normal use and service for which it was recommended (except for parts that are typically replaced after normal usage, such as filters, liner plates, etc.). Conair's guarantee is limited to replacing, at our option, the part or parts determined by us to be defective after examination. The customer assumes the cost of transportation of the part or parts to and from the factory.

PERFORMANCE WARRANTY

Conair warrants that this equipment will perform at or above the ratings stated in specific quotations covering the equipment or as detailed in engineering specifications, provided the equipment is applied, installed, operated and maintained in the recommended manner as outlined in our quotation or specifications.

Should performance not meet warranted levels, Conair at its discretion will exercise one of the following options:

- Inspect the equipment and perform alterations or adjustments to satisfy performance claims. (Charges for such inspections and corrections will be waived unless failure to meet warranty is due to misapplication, improper installation, poor maintenance practices or improper operation.)
- Replace the original equipment with other Conair equipment that will meet original performance claims at no extra cost to the customer.
- Refund the invoiced cost to the customer. Credit is subject to prior notice by the customer at which time a Return Goods Authorization Number (RGA) will be issued by Conair's Service Department. Returned equipment must be well crated and in proper operating condition, including all parts. Returns must be prepaid.

Purchaser must notify Conair in writing of any claim and provide a customer receipt and other evidence that a claim is being made.

WARRANTY LIMITATIONS

Except for the Equipment Guarantee and Performance Warranty stated above, Conair disclaims all other warranties with respect to the equipment, express or implied, arising by operation of law, course of dealing, usage of trade or otherwise, including but not limited to the implied warranties of merchantability and fitness for a particular purpose.

COMMANDER SE CONTROL TECHNIQUES START UP

-
- Step 1** Insure drive is the correct voltage for the unit. Also check phase 2 or 3.
- Step 2** Power up unit and press the (M) button. This will allow you to set parameters. See note below.
- Step 3** Refer to parameter set up sheet *Appendix B-2*.
- Step 4** Drive must be enabled to autotune.
- Step 5** Once Autotune is complete set parameter 5 to pad and enable the drive.
- Step 6** Check motor rotation by pressing the (I) button to start the drive. Next, press the (Δ) button to start the motor turning. Once rotation is determined press the (O) button to stop the drive.
- Step 7** Re-enter A1, A2 in parameter 5.

NOTE: To change a parameter first access parameters by pressing the (M) button. Once parameters are accessed you can scroll to the parameters with the (Δ) and (▽) buttons. To change a value press the (M) button until the parameters value is flashing. Then use the (Δ) or (▽) buttons to scroll to the desired value. Once the desired value is reached press the (M) button to get back to parameter view, now the parameter number will be flashing. Once all of the parameters are set press and hold the (M) button until the drive resets.

To change views when the unit and vacuum motor is running press and hold the (M) button.

One view you will see Fr in the left view window and the actual motor frequency in the right window. It should read about 6.8 with the motor stopped. The other view you will see A in the left view window and the actual motor current in the right window. This is the AC current of the motor.

Before shipping be sure that the view is set to Fr.

Each time a parameter is adjusted you must reset the drive to lock the value you entered. Press and hold the (M) button to reset the drive.

COMMANDER SE CONTROL TECHNIQUES PARAMETER SETUP

Parameter Number	Setting
1	6.8
2	60 (may need to adjust per unit)
3	1 sec
4	3 sec
5	A1, A2
6	motor FLA nameplate
7	motor rpm nameplate
8	voltage of unit
9	motor power factor
10	must be L2 to access parameters 11-44
	NOTE: After testing set to L1
16	needs set only if using input AZ terminal 5
22	A
23	Fr
26	OFF
30	1
31	1
32	OFF
33	0
34	ON
36	Fr
38	Once all parameters are set enter value of I and enable drive to autotune. Wait until the autotune is complete before starting drive.
39	unit Hz - 50 or 60 determined by rpm of motor
40	low rpm - 1759 = 4 pole high rpm - 3250 = 2 pole