

User Guide

Combination Puller/Cutter

Model CPC-218/10D

Installation

Operation

Maintenance

Troubleshooting

*Instant Access
Parts and Service*

(800) 458-1960

(814) 437-6861

www.conairnet.com



CONAIR™

The Conair Group, Inc.
One Conair Drive
Pittsburgh, PA 15202
Phone: (412) 312-6000
Fax: (412) 312-6227

UGE061/ACHV



WARNING - Reliance on this Manual Could Result in Severe Bodily Injury or Death!

This manual is out-of-date and is provided only for its technical information, data and capacities. Portions of this manual detailing procedures or precautions in the operation, inspection, maintenance and repair of the product forming the subject matter of this manual may be inadequate, inaccurate, and/or incomplete and cannot be used, followed, or relied upon. Contact Conair at info@conairgroup.com or 1-800-654-6661 for more current information, warnings, and materials about more recent product manuals containing warnings, information, precautions, and procedures that may be more adequate than those contained in this out-of-date manual.

Record your equipment's model and serial number(s) and the date you received it in the spaces provided.

It is important to record the model and serial number(s) of your equipment and the date you received it in the User Guide. Our service department uses this information, along with the manual number, to provide help for the specific equipment you installed.

Keep this User Guide and all manuals, engineering prints and parts lists together for documentation of your equipment.

Date:
Document Number: UGE061/ACHV
Serial number(s):
Model number(s):
Power Specifications: Amps Volts Phase Cycle

DISCLAIMER: The Conair Group, Inc., shall not be liable for errors contained in this User Guide or for incidental, consequential damages in connection with the furnishing, performance or use of this information. Conair makes no warranty of any kind with regard to this information, including, but not limited to the implied warranties of merchantability and fitness for a particular purpose.

TABLE OF CONTENTS

INTRODUCTION	1-1
Purpose of the User Guide	1-2
How the Guide is Organized	1-2
Your Responsibilities as a User	1-2
ATTENTION: Read this so no one gets hurt	1-3
How to Use the Lockout Device	1-5
DESCRIPTION	2-1
What is the Combination Puller/Cutter?	2-2
Typical Applications	2-2
Limitations	2-3
How the Combination Puller/Cutter Works	2-4
Combination Puller/Cutter Features	2-6
Specifications	2-7
Optional Equipment	2-8
INSTALLATION	3-1
Unpacking the Boxes	3-2
Preparing for Installation	3-3
Positioning the Combination Puller/Cutter	3-4
Connecting the Main Power Source	3-5
Installing the Cutter Blades	3-6
Mounting the Cutter Bushings	3-7
Adjusting Belt Tension	3-8
Setting the Belt Gap	3-9
Checking Repeatability	3-10
Repeatability Test Results	3-11
Checking Programming Values	3-12
Preparing for Testing	3-14
Testing the Installation	3-15
OPERATION	4-1
The Cutter Control	4-2
The Puller and Cutter Blade Speed Controls	4-3
Cutter Control Features	4-4
Puller Control and Cutter Blade Control Features	4-7
Combination Control Features	4-8
Before Starting	4-9
Powering Up	4-10
Programming the Puller Speed	4-11
Setting the Blade Speed	4-11
Choosing the Cutting Mode	4-12
Setting the Cutting Mode	4-13
Setting the Prescale Value	4-14
Checking Cut Quality	4-15
Starting the Combination Puller/Cutter	4-15
Making Adjustments During Operation	4-16

TABLE OF CONTENTS

OPERATION cont'd

Making Large Changes to the Puller Speed	4-16
Making Large Changes to the Blade Speed	4-16
Fine-tuning Puller and Blade Speed	4-17
Making a Manual Cut	4-17
Counting the Number of Cuts	4-17
Adjusting Cutter Preset Values	4-18
Temporarily Stopping Cutting	4-18
Stopping Only the Cutter	4-18
Stopping the Combination Puller/Cutter	4-19
Shutting Down the Combination Puller/Cutter	4-20

MAINTENANCE 5-1

Maintenance Features	5-2
Warnings and Cautions	5-2
Preventative Maintenance Schedule	5-4
Inspecting Cutter Blades	5-6
Inspecting Blade Hardware	5-6
Inspecting Cutter Bushing Screws	5-7
Checking the Closure Latch	5-7
Checking Floor Locks	5-7
Replacing Motor Brushes	5-8
Adjusting the Cutter Proximity Switches	5-9
Checking Electrical Connections	5-10
Testing Belt Tension	5-12
Checking the Belt Gap	5-14
Replacing Belts	5-15
Checking Torque	5-16

TROUBLESHOOTING 6-1

Before Beginning	6-2
A Few Words of Caution	6-2
Identify the Cause of a Problem	6-4
Puller Operation Problems	6-5
Cutter Operation Problems	6-7
Product Quality Problems	6-11
Restoring Default Memory Settings	6-16
Restoring User-Specific Memory Settings	6-16
Replacing Safety and Proximity Switches	6-17
Adjusting the Proximity Switches	6-18
Checking the Motor/Clutch/Brake Assembly	6-19
Testing Repeatability	6-20
Results of Repeatability Testing	6-21

APPENDIX

- Customer Service InformationA-1
- Cutter Blade SelectionB-1
- All About Cutter BushingsC-1
- Blade and Bushing LubricationD-1
- Choosing Belt MaterialsE-1
- Control SettingsF-1
- Using the Digital Belt Gap SensorG-1

**TABLE OF
CONTENTS**

PARTS/DIAGRAMS

This section has been provided for you to store spare parts lists and diagrams.

INTRODUCTION

- *Purpose of the User Guide1-2*
- *How the User Guide
is Organized1-2*
- *Your Responsibilities
as a User1-2*
- *ATTENTION: Read this so
no one gets hurt1-3*
- *How to Use the
Lockout Device1-5*

PURPOSE OF THE USER GUIDE

This User Guide describes the Conair Combination Puller/Cutter and explains step-by-step how to install, operate, maintain and repair this equipment.

Before installing this product, please take a few moments to read the User Guide and review the diagrams and safety information in the instruction packet. You also should review manuals covering associated equipment in your system. This review won't take long, and it could save you valuable installation and operating time later.

HOW THE USER GUIDE IS ORGANIZED

Symbols have been used to help organize the User Guide and call your attention to important information regarding safe installation and operation.



Symbols within triangles warn of conditions that could be hazardous to users or could damage equipment. Read and take precautions before proceeding.



Numbers within shaded squares indicate tasks or steps to be performed by the user.



A diamond indicates the equipment's response to an action performed by the user.



An open box marks items in a checklist.



A shaded circle marks items in a list.

YOUR RESPONSIBILITY AS A USER

You must be familiar with all safety procedures concerning installation, operation and maintenance of this equipment. Responsible safety procedures include:

- Thorough review of this User Guide, paying particular attention to hazard warnings, appendices and related diagrams.
- Thorough review of the equipment itself, with careful attention to voltage sources, intended use and warning labels.
- Thorough review of instruction manuals for associated equipment.
- Step-by-step adherence to instructions outlined in this User Guide.

We design equipment with the user's safety in mind. You can avoid the potential hazards identified on this machine by following the procedures outlined below and elsewhere in the User Guide.

**⚠ ATTENTION:
READ THIS SO NO
ONE GETS HURT**



DANGER: Sharp blades!

Most injuries caused by knife blades occur when the cutter has been turned off. Handle blades with care at all times.



- Always wear cut-resistant gloves when the cutting chamber is open and when handling blades.
- Always lock out the cutter before opening the cutting chamber.
- Always wait until the cutter head has stopped completely before opening the knife guard.

The puller/cutter combo is equipped with several safety devices to ensure safe operation. Never remove or disable these devices to sustain production. Operating without these devices can cause severe injury.

- When the knife guard is opened, the knife guard switch stops the cutter and prevents starting the cutter again.
- Two proximity-type safety switches prevent operation unless the cutter bushings are in place.
- The Cutter Stop button activates a circuit that stops the knife.



WARNING: Improper installation, operation, or servicing may result in equipment damage or personal injury.

This equipment should only be installed, adjusted, and serviced by qualified technical personnel who are familiar with the construction, operation, and potential hazards of this type of machine.

All wiring, disconnects, and fuses should be installed by qualified electrical technicians in accordance with electrical codes in your region. Always maintain a safe ground. Do not operate the equipment at power levels other than what is specified on the machine serial plate.

**⚠ ATTENTION:
READ THIS SO NO
ONE GETS HURT**



WARNING: Voltage Hazard

This equipment is powered by one- or three-phase alternating current, as specified on the machine serial tag and data plate.

A properly-sized conductive ground wire from the incoming power supply must be connected to the chassis ground terminal inside the electrical enclosure. Improper grounding can result in severe personal injury and erratic machine operation.

Always disconnect and lockout power before opening the electrical enclosure or performing non-routine procedures such as maintenance.



DANGER: Pinch Hazard!

Never remove or disable safety devices to sustain production. Operating without these devices could lead to hazardous conditions that can cause severe injury.

- Walk-through style belt guards which protect from injury, but also allow side entry for ease of operation. Upper and lower belt guards independently protect the operator from being caught in the belts or associated driven sheaves.
- The emergency stop (E-stop) button is located on the control panel. Pressing either of these disconnects power to the entire unit. The E-stop must be physically pulled up to reset the switch and start the combination puller/cutter again.
- When the knife guard is opened, the knife guard switch stops the cutter and prevents starting the cutter again.
- Two proximity safety switches prevent cutter operation unless the cutter bushings are in place.
- The Stop button on the cutter control activates a circuit that stops the knife.



WARNING: Electrical hazard

Before performing maintenance or repairs on this product, disconnect and lock out electrical power sources to prevent injury from unexpected energization or start-up. A lockable device has been provided to isolate this product from potentially hazardous electricity.

HOW TO USE THE LOCKOUT DEVICE

Lockout is the preferred method of isolating machines or equipment from energy sources. Your Conair product is equipped with the lockout device pictured below. To use the lockout device:

- 1** Stop or turn off the equipment.
- 2** Isolate the equipment from electrical power. Turn the rotary disconnect switch to OFF or O position.
- 3** Secure the device with an assigned lock or tag.
- 4** The equipment is now locked out.

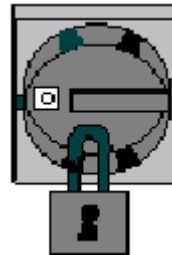

CAUTION: Moving parts

Before removing lockout devices and returning switches to the ON position, make sure that all personnel are clear of the machine, tools have been removed and all safety guards are reinstalled.

DESCRIPTION

- ***What is the Combination
Puller/Cutter?2-2***
- ***Typical Applications2-2***
- ***Limitations2-3***
- ***How the Combination
Puller/Cutter Works2-4***
- ***Combination Puller/
Cutter Features2-6***
- ***Specifications2-7***
- ***Optional Equipment2-8***

WHAT IS THE COMBINATION PULLER/CUTTER?

The Conair CPC-218/10D Combination Puller/Cutter pulls small-sized extruded products through sizing and/or cooling tanks and cuts the product to lengths. Since the puller and cutter are mounted on the same chassis, alignment problems are minimized.

The puller portion's direct DC drive system offers extremely good speed control. Different puller belt materials optimize performance with different types of extruded materials.

The cutter portion utilizes a variable speed DC drive system to power a pneumatic clutch brake. A cutter head is installed on the brake output shaft, which cuts the material.

TYPICAL APPLICATIONS

The Conair CPC-218/10D Combination Puller/Cutter is designed to pull and cut small diameter flexible tubing.

LIMITATIONS

- Because the maximum distance between the puller and cutter is only six inches, the combination puller cutter is not suitable for rigid extruded parts.
- The unit is limited by the traction length (the length over which the extrudate is in contact with the puller belts), which is fixed for a particular model.
- The outer surface of the puller belt material will affect performance. Softer (low durometer) materials provide good 'grab', but will wear more quickly, and may tear if the belt jams. Harder materials last longer, but may not grab the extrudate properly.

Contact Conair for specific belt material recommendations for your product.

HOW THE COMBINATION PULLER/CUTTER WORKS

Extruded material that has been sized and cooled enters the combination puller cutter from the upstream side. The extrudate passes through and is positioned by guide rollers (step 1, page 2-5).

Two opposing belts move the extrudate through the puller (step 2). These belts have grooves that fit the teeth on the rolls, preventing side-to-side movement. Belt coverings are available in a variety of materials for your needs. Walk-through style belt guards ensure operator safety while allowing access to the belts. The belt speed is controlled by eye-level controls.

After passing through the belts, the pulled material continues on to the cutter. The cutter is mounted on linear slides that allow as much as 6 inches of movement. The cutter can be moved away from the puller for startup, then moved close to the puller to enhance delivery to the cutter bushings.

The cutter's DC motor is directly coupled to a pneumatic clutch/brake and drives the cutter head.

The cutting knife, attached to the cutter head, is driven by the DC motor. Two cutter bushings guide and support both the extrudate and the cutting knife. The extrudate passed through the cutter bushings and is cut by the rotating cutter head (step 3). The cutter head is mounted directly to the clutch/brake shaft using a Trantorque coupling device.

Cut pieces are collected or carried on to further processing after they exit the cutter (step 4) by an optional conveyor.

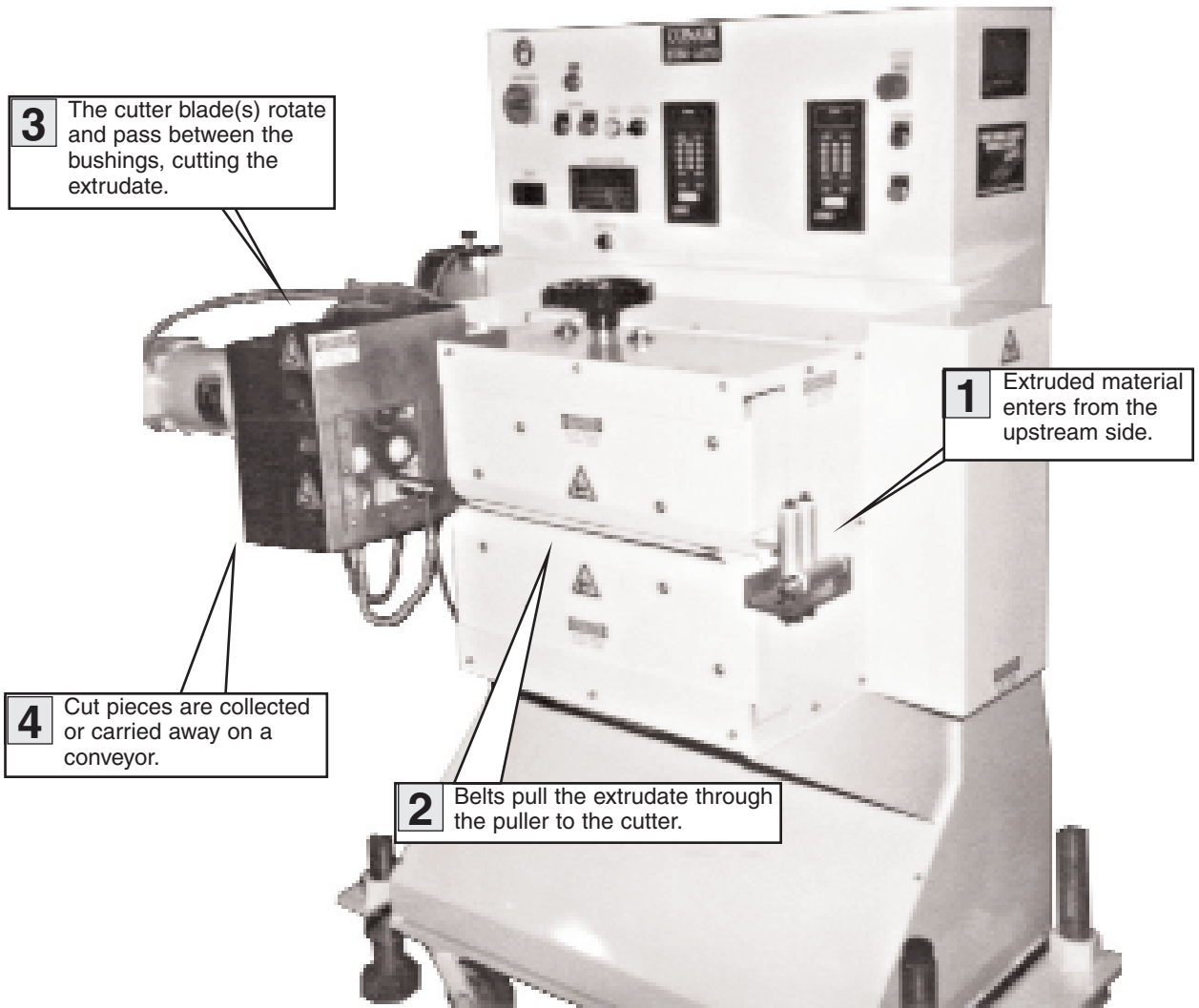

3 The cutter blade(s) rotate and pass between the bushings, cutting the extrudate.

1 Extruded material enters from the upstream side.

4 Cut pieces are collected or carried away on a conveyor.

2 Belts pull the extrudate through the puller to the cutter.

COMBINATION PULLER/CUTTER FEATURES

The Combination Puller/Cutters have these features:

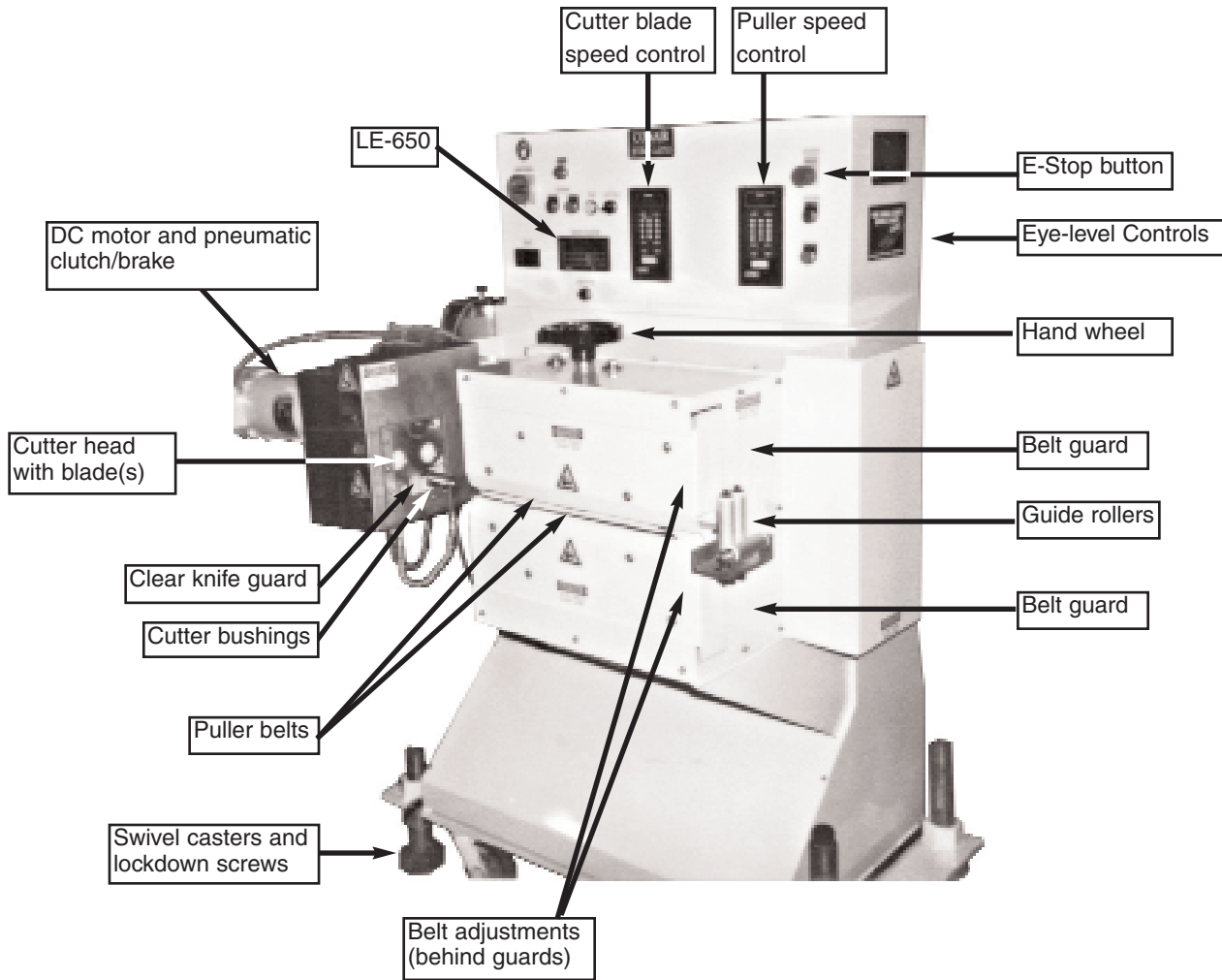

Standard features and specifications include:

SPECIFICATIONS

Frame	<ul style="list-style-type: none">● Common frame for puller and cutter, welded steel construction with casters, floor locks and pads. Standard paint is white enamel.
Puller	<ul style="list-style-type: none">● 2" wide x 12" contact length, Poly-V belt with 35 durometer material rubber covers (FDA) white.● 1 HP Digital DC Drive (Fenner M-Trim) with keypad and LED readout (+/- 1/10% speed regulation) with pneumatic clutch/brake with digital control.● 1.5" belt opening with both belts opening and closing off of center-line. Fully guarded with walk-through style guards and built-in emergency stop pushbutton.
Cutter	<ul style="list-style-type: none">● 0.5" cutting capacity (1 1/4" OD cutter bushings).● 1/2 HP Digital DC drive (Fenner M-Trim) with keypad and LED readout (+/- 1/10% speed regulation) with pneumatic clutch/brake with digital control.● Up to 300 cuts per minute in on-demand operation and up to 750 cuts per minute in continuous (flywheel) operation.● Cut length control (LE650 with LED readout) for counter/encoder, continuous, timer, or end sense modes (end sense actuation device is optional), resettable totalizing product counter. 600 pulse bi-directional encoder is included.● Slide base with rails and adjustable stop.● Blade/Bushing lubricator with reservoir and control valve.● One set of stainless steel cutter bushings included (blank).
Electrical	<ul style="list-style-type: none">● Common panel for puller and cutter controls, including transformer.● Lockable rotary disconnect.● Standard voltage is 230V/1 phase/60Hz.

Optional features and specifications include:

Puller	<ul style="list-style-type: none">● Choose 18" of traction assembly in place of standard 12".● Electronic Totalizing Footage counter.● Emerson Servo Drive (single axis) position control with T60 serial operator interface with all belt drive.
Cutter	<ul style="list-style-type: none">● Emerson servo drive with in-line planetary reducer for cutter. Eliminates clutch/brake noise, particulate. Includes rollover mode.● Parts ejection control system with delay and duration potentiometers with powered output (Lyons output controller) <p>NOTE: Control interfaces with Conair discharge conveyor with automatic parts ejection system.</p>

OPTIONAL EQUIPMENT

Digital belt gap sensor and readout (puller)

This option allows the operator to set a zero point, then measure belt gap (in thousandths) relative to this point.

Remote belt speed control (puller)

This option allows puller speed control by an external source.

Electronic totalizing footage counter (puller)

This option allows the operator to view how much product has passed through the puller based on input from an encoder. The counter may be zeroed at any time and rescaled as needed.

Velocity or positional servomotor with serial operator interface (puller)

The standard DC puller drive can be replaced by a servomotor for applications requiring extreme accuracy. Both velocity and velocity-positional control units are available.

Different reducer ratios (puller)

A particular reducer ratio is selected at the time of purchase to optimize puller performance in a particular speed range.

Cutter Bushing Lubrication

This is a self-contained spray system, which includes a reservoir and air inlet for operation at 20-30 psig (air source not included). A flexible nozzle directs lubricant onto the extrudate as it enters the cutter bushings. This decreases bushing drag and helps lubricate the blade. This option is particularly recommended for processing sticky/soft (low durometer) materials.

Cutter Blade Wipe

The blade wipe system keeps the cutting blade clean by removing lubricant and particles from the blade. A reservoir chamber with a flexible drip tube feeds lubricant to a felt pad in the lubrication tray. The pad wipes and lubricates the knife before each cut.

OPTIONAL EQUIPMENT

Discharge Conveyor

A discharge conveyor offers support before, during, and after cutting, and facilitates the removal of cut parts. Discharge conveyors are available in the following sizes:

- 6 inches wide by 6 feet long
- 6 inches wide by 12 feet long
- 6 inches wide by 16 feet long

Isolation Transformer

The isolation transformer protects sensitive electronics from incoming power, which helps prevent errors caused by electrical noise.

NOTE: An isolation transformer will not compensate for a ground that does not meet code requirements.

NOTE: Conair strongly recommends using an isolation transformer. Ensuring clean and proper power can help avoid the need for costly service calls.

Left to Right Machine Operation

This option changes the machine direction from the standard right to left extrusion flow.

INSTALLATION

- *Unpacking the Boxes*3-2
- *Preparing for Installation*3-3
- *Positioning the
Combination Puller/Cutter* ...3-4
- *Connecting the Main
Power Source*3-5
- *Installing the Cutter
Blades*3-6
- *Mounting the Cutter
Bushings*3-7
- *Adjusting Belt Tension*3-8
- *Setting the Belt Gap*3-9
- *Checking Repeatability*3-10
- *Repeatability Test Results* ...3-11
- *Checking Programming
Values*3-12
- *Preparing for Testing*3-14
- *Testing the Installation*3-15

UNPACKING THE BOXES

The Conair Combination Puller/Cutter comes fully assembled in a single crate.



CAUTION: Lifting

To avoid personal injury or damage to the cutter, lift the cutter using a forklift or hoist with straps that have been positioned at the cutter's center of gravity.

- 1 Carefully uncrate the puller/cutter** and its components.
- 2 Remove all packing material**, protective paper, tape, and plastic. Compare contents to the shipping papers to ensure that you have all the parts.
- 3 Carefully inspect all components** to make sure no damage occurred during shipping. Check all wire terminal connections, bolts, and any other electrical connections, which may have come loose during shipping.
- 4 Record serial numbers and specifications** in the blanks provided on the back of the User Guide's title page. This information will be helpful if you ever need service or parts.
- 5 You are now ready to begin installation.** Complete the preparation steps on page 3-3.

PREPARING FOR INSTALLATION

1 You will need these tools for installation:

- wire strain relief
- 16- or 18-inch adjustable wrench
- set of Allen wrenches
- set of feeler gauges
- ½ inch open or box end wrench
- flashlight

2 Plan the location. Make sure the area where the combination puller/cutter is installed has the following:

- **A grounded power source.** Check the serial tag for the correct amps, voltage, phase and cycles. All wiring should be completed by qualified personnel and should comply with your region's electrical codes.
- **Clearance for safe operation and maintenance.** Make sure there is enough clearance around the device for maintenance and servicing.



WARNING: Improper installation, operation, or servicing may result in equipment damage or personal injury.

This equipment should only be installed, adjusted, and serviced by qualified technical personnel who are familiar with the construction, operation, and potential hazards of this type of machine.

All wiring, disconnects, and fuses should be installed by qualified electrical technicians in accordance with electrical codes in your region. Always maintain a safe ground. Do not operate the equipment at power levels other than what is specified on the machine serial tag and data plate.

POSITIONING THE COMBINATION PULLER/CUTTER

- 1 Move the combination puller/cutter into position.** Place the puller/cutter in position downstream of the last sizing or cooling tank.



CAUTION: Lifting

To avoid personal injury or damage to the cutter, lift the cutter using a forklift or hoist with straps that have been positioned at the combo's center of gravity.

- 2 Align the puller/cutter with the extrusion line.**

- 3 Measure the centerline height** of the extrudate as it exits the extrusion die. Adjust all equipment on the extrusion line (sizing tank, cooling tanks, puller/cutter) to this height.

- 4 Adjust the puller/cutter's floorlock/caster assembly** to the center height of the extrusion line using a 16- or 18-inch adjustable wrench. Remove the weight from the casters by locking down the floorlocks.

NOTE: Never leave the puller/cutter on casters only.

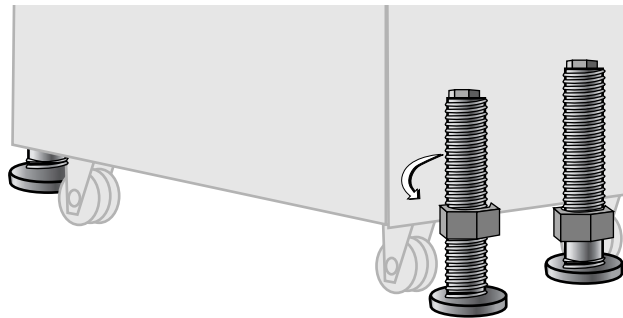

- 5 Use a plumb line or laser to check for a straight line** from the extrusion die through each line component to the cutter bushings. Adjust as necessary.
- 6 Adjust the belt puller entrance guide rollers** to insure consistent product guidance.



WARNING: Electrical hazard

Before performing any work on this product, disconnect and lock out electrical power sources to prevent injury from unexpected energization or start-up. A lockable device has been provided to isolate this product from potentially hazardous electricity.



WARNING: Improper installation, operation, or servicing may result in equipment damage or personal injury.

This equipment should only be installed, adjusted, and serviced by qualified technical personnel who are familiar with the construction, operation, and potential hazards of this type of machine.

All wiring, disconnects, and fuses should be installed by qualified electrical technicians in accordance with electrical codes in your region. Always maintain a safe ground. Do not operate the equipment at power levels other than what is specified on the machine serial tag and data plate.

CONNECTING THE MAIN POWER SOURCE

- 1 Open the combination puller/cutter's electrical enclosure.** Turn the disconnect dial on the door to the OFF or O position and open the door.



- 2 Insert the main power wire** through the knockout in the side of the enclosure. Secure the wire with a rubber compression fitting or strain relief.

- 3 Connect the power wires** to the terminals indicated on the wiring diagram that came with your machine.

- 4 Check every terminal screw** to make sure wires are secure. Gently tug each wire. If a wire is loose, use a screwdriver to tighten the terminal.

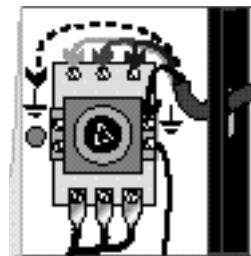

- 5 Connect the ground wire** to the grounding point shown in the wiring diagram shipped with your unit.

IMPORTANT: Always refer to the wiring diagrams that came with your combination puller/cutter before making electrical connections. The diagrams show the minimum size main power cable required for your cutter, and the most accurate electrical component information.

INSTALLING THE CUTTER BLADES



DANGER: Sharp blades!

Most injuries caused by knife blades occur when the cutter has been turned off. Handle blades with care at all times.



- Always wear cut-resistant gloves when the cutting chamber is open and when handling blades.
- Always lock out power to the cutter before opening the cutting chamber.
- Always wait until the cutter head has completely stopped before opening the knife guard.

Combination puller/cutters are equipped with several safety devices to ensure safe operation. Never remove or disable these devices to sustain production. Operating without these devices can cause severe injury.

- When the knife guard is opened, the knife guard switch stops the cutter and prevents starting the cutter again.
- Two proximity-type safety switches prevent operation unless the cutter bushings are in place.
- The Cutter Stop button activates a circuit that stops the cutter head.

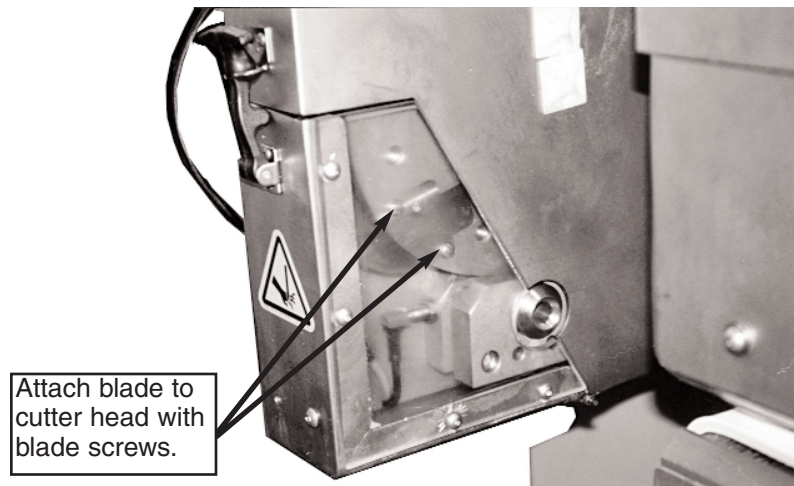

For on-demand cutting, mount the blade at the “on-demand” position stamped on the cutter head.

For more information about choosing the appropriate blade for your material, see the Appendix, starting on page B-1.



DANGER: Sharp blades!

Always wear cut-resistant gloves when the cutting chamber is open and when handling blades. Never open cutting chamber without locking out the cutter power and waiting until the cutter head stops spinning.



MOUNTING THE CUTTER BUSHINGS

- 1 Rotate the cutter head** until the blade is positioned in the gap between where the bushings go.
- 2 Slide the downstream bushing into position**, positioning it up to and barely touching the blade (using a feeler gauge). NOTE: the blade should not be deflected.
- 3 Tighten the set screw** against the flat side of the bushing to hold the bushing in position.

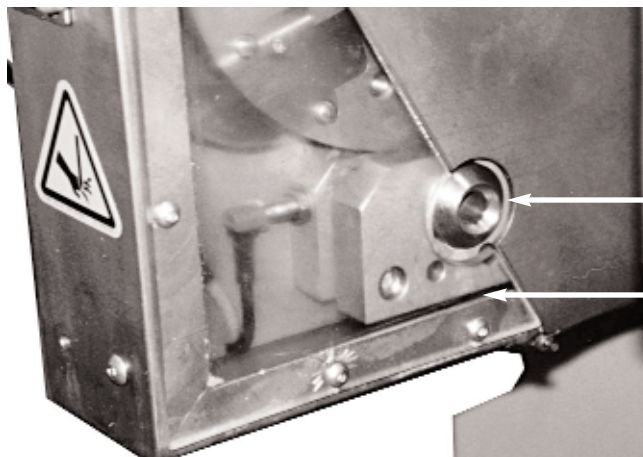

Cutter bushings

Location of set screws (2), visible when knife guard is open.

- 4 Slide the upstream bushing into position**, positioning it up to but not touching the blade. Use feeler gauge.
- 5 Tighten the set screw against the flat side** of the bushing to hold the bushing in position.
- 6 Rotate the cutter head by hand** to make sure the bushings did not move, and the blade still passes through the gap between the bushings.

For more information about setting and adjusting the gap for the bushings, see About Cutter Bushings, in the Appendix, page C-1.

ADJUSTING BELT TENSION

1 Turn the main power disconnect to the off position.

2 Remove the upper and lower belt guards:

- Remove the screws attaching guards to unit.

- Lift off and remove guard.

Check belt tension. Use a tension-measuring tool. Belts should be just tight enough to prevent slipping, and the gap between the upper and lower belts should be even across the width of the belt.

3

NOTE: Loose belts result in belt and product slippage; over-tightened belts result in distorted product and can lead to premature bearing failure.

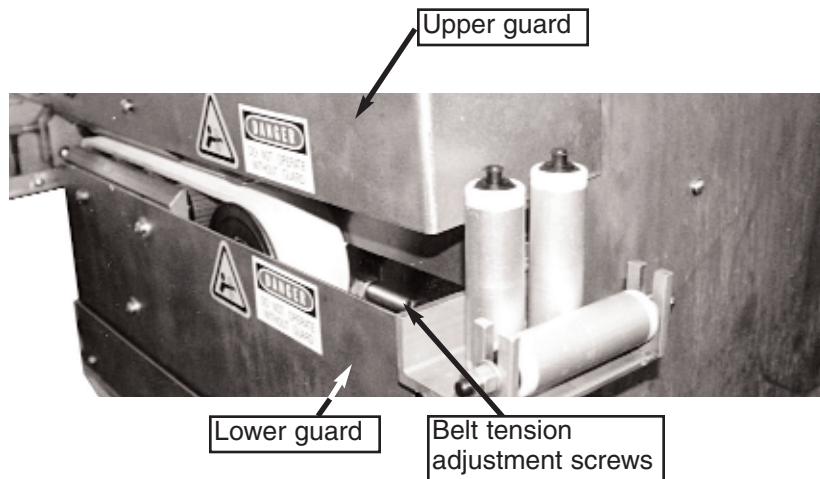

4 Adjust belt tension, if necessary.

Adjust tension by turning the threaded tension rods. Keep tension on front and back edges, top and bottom belts as even as possible.

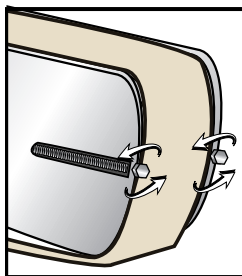

5 Fine tune tension:

- **Lower the belts** to a gap of about 1/8" (3 mm).
(See Setting the Belt Gap, page 3-9.)
- **From the upstream end of the belts**, look down the length of the belts at the gap between the belts. If the gap is not even, adjust the tension until the gap is even and measures 1/8". The shape of the gap should not be concave (over-tightened) or convex (too loose).
- **Check tension and readjust as necessary.**

The upper and lower belt boom assemblies are controlled by a common threaded rod. Turn the hand wheel to move the belts up and down.

SETTING THE BELT GAP

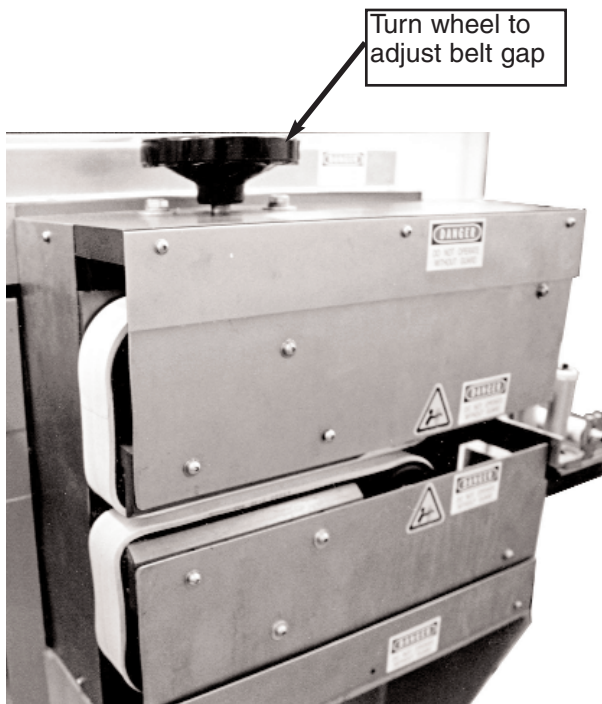

CHECKING REPEATABILITY

Before any Conair puller/cutters are shipped, they are tested for cut time repeatability to be sure they are within performance specifications. The repeatability test checks the performance of the rotary knife cutter to return the home park position after a complete cut. Acceptable repeatability times allowed for each cutter model prior to shipping are:

The repeatability mode is built into the Conair cutter controls and allows you to perform similar tests, without any external test equipment. It is recommended that you check repeatability on a regular basis. Acceleration/deceleration delays of the optional servomotor do not contribute to repeatability error; any error is attributed solely to motor stability, couplings, assembly, power, and proximity sensor alignment.

Use any blade speed and line speed. The line speed is only seen while in the Encoder or Product modes. It is recommended that the tests be performed at cut intervals between 0.5 and 5-seconds. Do not change the blade speed or the line speed after starting the test.

To test repeatability:

- 1 Turn on the cutter.** Performing the test with the cutter off-line shows problems with the cutter; performing the test with the cutter on-line shows a problem with the puller.
- 2 Place the cutter in any mode.**
- 3 Press the Cut On/Off button;** the cutter is activated automatically.
- 4 Press and hold the Move Right button** for a minimum of 5 seconds. 
- 5 Read the results on the display.**
Repeat the test by pressing the Reset/Test Cut button to begin a new sample period.

To end the Repeatability test, press any button except the Reset/Test Cut button. The LED returns to its normal display.

REPEATABILITY TEST RESULTS

Results in Flywheel mode

The display shows "Repeat Test" and the park-to-park (PP) reading. This is the total (peak) variance of a full revolution of the cutter head. The reading is in milliseconds, to the third decimal place, i.e. 0.010 is 0.01 milliseconds (or 10 microseconds). If the reading exceeds 9.999 the unit automatically resets the repeatability test, displays "Over Run", and attempts to begin the test again. If this occurs the error is too large and there is a fault in the cutter drive that must be corrected.

Results in Timer mode

When testing repeatability in Timer mode, the cutter is making on-demand cuts at a set time interval (i.e. one-second intervals). The display shows "Repeat Test", and then the cut-to-park (CP) reading and the cut-to-cut (CC) reading in milliseconds, to the third decimal place (i.e. 0.010 is 0.01 milliseconds [or 10 microseconds]).

CP is the peak time variance between the cut signal output (preset time) to the clutch/brake control, and the proximity switch just prior to the end of the cut cycle. This is the repeatability of the cutting system to return to the home park position. This value is higher than the PP reading since it includes the acceleration and deceleration contributed by the DC motor and clutch/brake performance.

CC is the peak time variance between cuts. Record and compare the cut-to-cut number to the CC value recorded in encoder or product mode shows how much error is by external influences (i.e. variation in belt puller speed, encoder mounting problem, etc.).

If the reading exceeds 9.999, the unit automatically resets the repeatability test, displays the message "Over Run", and attempts to begin the test again. If this occurs the error is too large and there is a definite fault that must be corrected.

Results in Encoder or Product mode

The display shows "Repeat Test", and then the cut-to-park (CP) reading and the cut-to-cut (CC) reading. The reading is in milliseconds, to the third decimal place, i.e. 0.010 is 0.01 milliseconds (or 10 microseconds).

Compare the cut-to-park (CP) reading to the CP reading in the other modes. There should be very little difference in these readings.

Compare the cut-to-cut (CC) reading to the CC reading in the other modes. Since the Encoder and Product modes are influenced by external signals, this reading will reflect the speed stability of the puller.

CHECKING PROGRAMMING VALUES

The M-Trim control has about 55 programmable control parameters. Some of these parameters are set by Conair as default values and others are set specifically for this combination puller/cutter.

The current value of each parameter is stored in memory and recovered on startup. However, the M-Trim control's memory can be corrupted by electrical noise, surges, etc, making it impossible to retrieve the current values. While the control can be reset to factory-default settings, any information specific to your puller will be lost unless you maintain a copy of the current control parameter values. You must have this information to return to normal operation. See Appendix, starting on page F-1, Control Settings, for the default settings and your particular settings. Any time you change these settings, record them on the Puller/Cutter Control Settings pages so you can easily reset your control. Some of the default codes are listed inside the flip-down cover of the control.

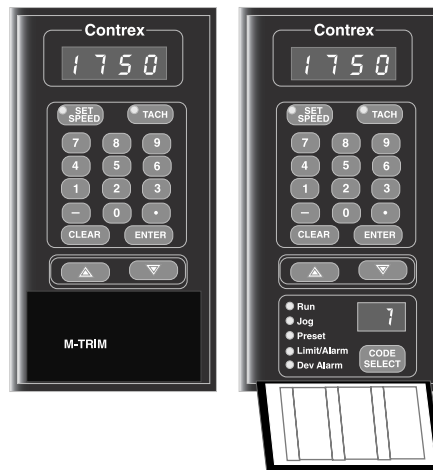

- 1 Turn on the device** by turning the main disconnect to the ON position. The microprocessor performs a self-diagnostic test (about 2 seconds) then enters the default STOP state:

Speed Command output = zero
(Parameters and setpoints are recovered from memory)

- 2 Open the controller's flip-down cover** to view the programming keypad.
- 3 Press the Code Select button** and enter the two-digit parameter code. Refer to Appendix, page F-1, Control Settings, for a complete list of parameter codes, descriptions, and settings.

4 Press the Enter button.

The two-digit parameter code displays in the lower LED window. The current value for that code displays in the upper LED window.

5 For each parameter, compare the value in the upper display to the value listed on page F-1, Control Settings, in the Appendix.

6 Continue to press the Enter button to view all the parameter codes. If any values differ from what is listed on the Control Settings page F-1, contact Conair Service immediately.

PREPARING FOR TESTING

- 1** **Make sure all components** are installed according to assembly drawings. Make sure that all bolts have been checked for tightness.
- 2** **Check that the combination puller/cutter is firmly locked** into position with the anchoring screws.
- 3** **Check that all wiring conforms to electrical codes**, and all wiring covers are in place.



DANGER: Pinch Hazard!

Never remove or disable safety devices to sustain production. Operating without these devices could lead to hazardous conditions that can cause severe injury. Take all necessary precautions when working around moving parts to prevent body parts and clothing from being pulled into the machine.

TESTING THE INSTALLATION

1 Turn on the main disconnect. Plug in the main power cord and turn on the main disconnect. The display should fully illuminate and perform its bootup routine.

2 Check that the E-Stop button is in the out, extended position.

NOTE: If the E-Stop button is pushed in, the guard LED on the control will not illuminate, even if all other safety features are in the proper positions.

3 Press the Start button. The light on the button should light and the puller belts begin to rotate.

4 Make sure that the Cut On/Off LED is Off. If necessary, press button to turn off LED.

5 Press Start Cutter button. The LED in the button should light.

6 Open the knife guard. The Machine Reset push button should light.

If the cutter is not working properly at any time, turn it off immediately and refer to the Troubleshooting section of this User Guide.

If you do not encounter any problems, proceed to the Operation section.

OPERATION

- *The Cutter Control*4-2
- *The Puller and Cutter Blade Controls* .4-3
- *Cutter Control Features*4-4
- *Puller and Cutter Blade Control Features*4-7
- *Combination Control Features*4-8
- *Before Starting*4-9
- *Powering Up*4-10
- *Programming the Puller Speed*4-11
- *Setting the Blade Speed*4-11
- *Choosing the Cutting Mode*4-12
- *Setting the Cutting Mode*4-13
- *Setting the Prescale Value*4-14
- *Checking Cut Quality*4-15
- *Starting the Puller/Cutter*4-15
- *Making Adjustments During Operation*4-16
- *Making Large Changes to the Puller Speed*4-16
- *Making Large Changes to the Blade Speed*4-16
- *Fine-tuning Puller & Blade Speed* ...4-17
- *Making a Manual Cut*4-17
- *Counting the Number of Cuts*4-17
- *Adjusting Cutter Preset Values*4-18
- *Temporarily Stopping Cutting*4-18
- *Stopping Only the Cutter*4-18
- *Stopping the Combo*4-19
- *Shutting Down the Puller/Cutter.* ...4-20

THE CUTTER CONTROL

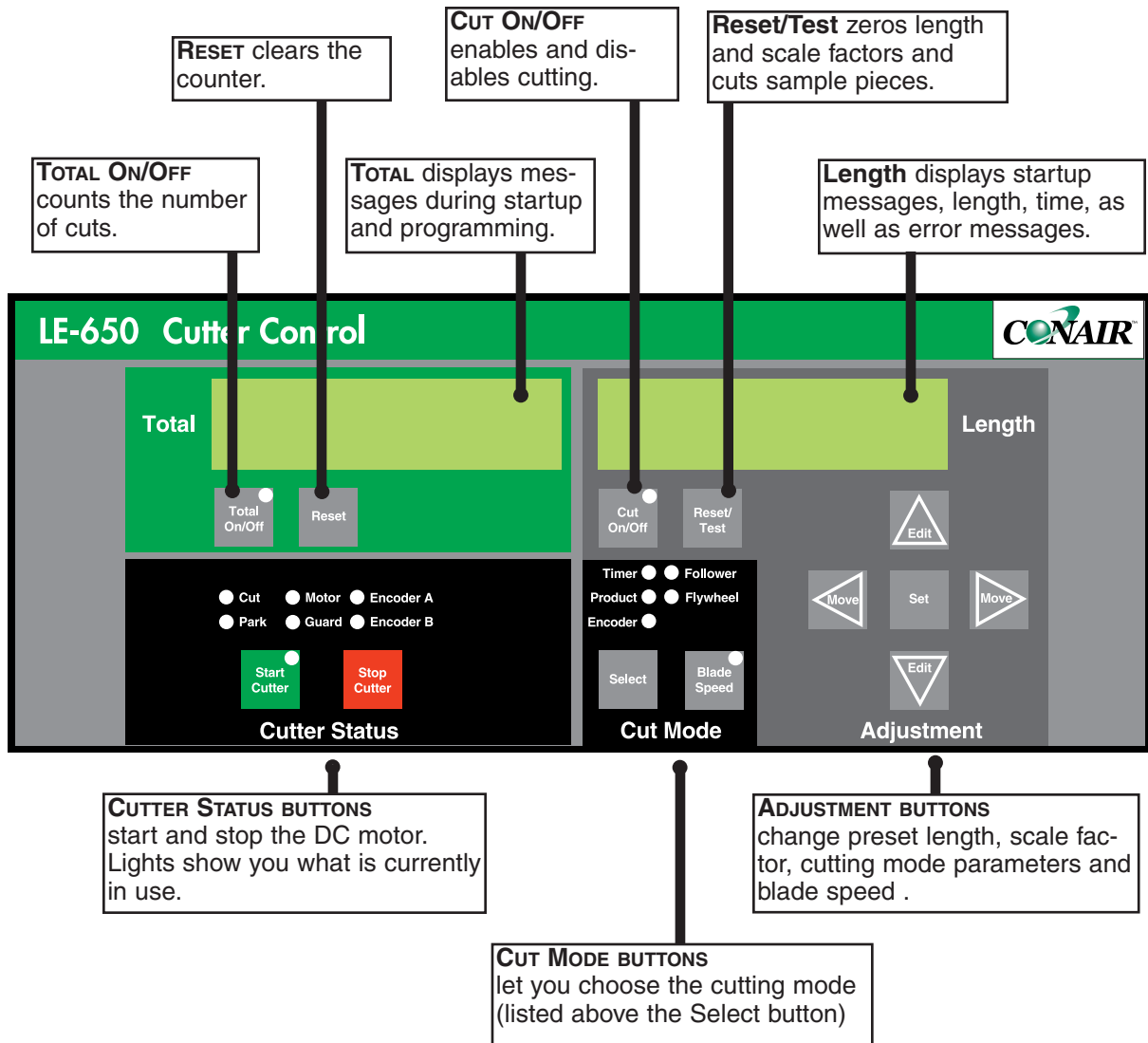

Detailed description of the Cutter Control begins on page 4-4.

THE PULLER AND CUTTER BLADE SPEED CONTROLS

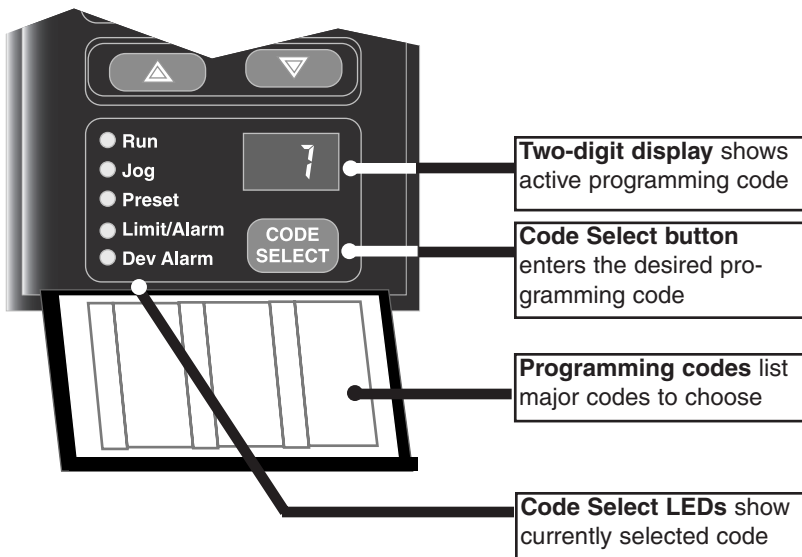
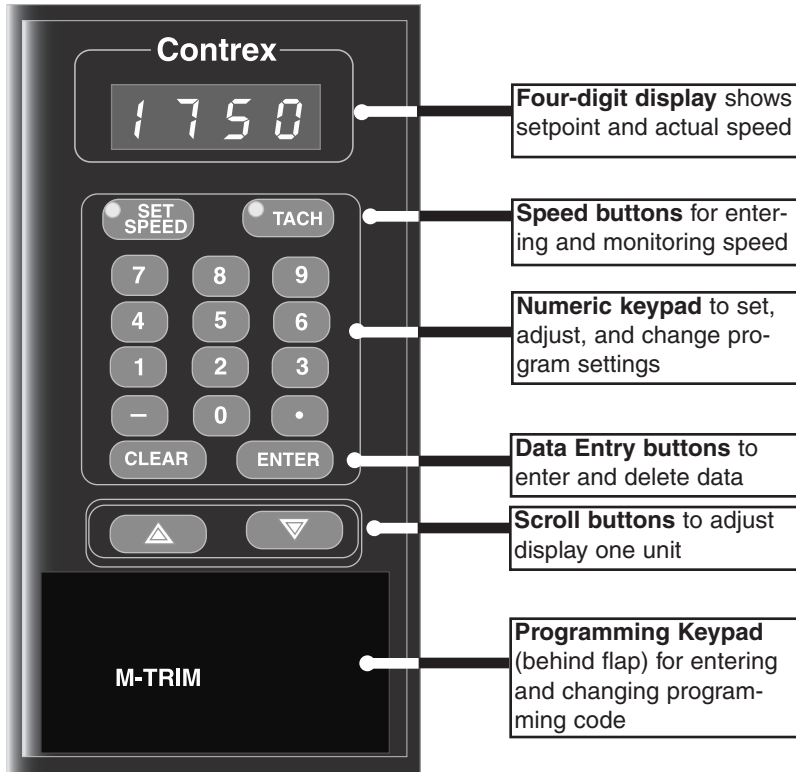

More detailed descriptions of this control begin on page 4-7.

CUTTER CONTROL FEATURES

The cutter control has several features that allow you to input setup information, monitor cutting process, and view errors.

Total information is located in the upper left of the control and consists of:

- **Total LED** displays messages during startup and programming. During normal operation, it shows the number of cuts if the counter has been activated. It also displays error messages. See Troubleshooting, starting on page 6-1, for more details about error messages.
- **Total On/Off button** activates a counter that allows you to monitor the number of cuts. This button is ON when the LED in the corner is lit.
- **Reset button** clears the counter and resets count to zero.

Length information is located on the right of the control and consists of:

- **Length LED** displays messages during startup. During programming, it shows the value of adjustable parameters. During normal operation, it shows either current length or elapsed time depending on the cutting mode. It also displays error messages. See Troubleshooting for more details about error messages.
- **Cut On/Off button** enables/disables automatic cutting.
- **Reset/Test button** has several functions:
 - ◆ It produces a sample cut during normal operation at the set blade speed while resetting the length count. The cut piece is not counted on the total counter.
 - ◆ It sets the length and scale factor presets to zero in programming mode.
- **Set button and Adjustment arrows** are used to:
 - ◆ Change preset length
 - ◆ Change preset scale factor
 - ◆ Change cutting mode parameters

CUTTER CONTROL FEATURES CONT'D

The adjustment arrows adjust some cutter parameters on a digit-by-digit basis:



Use the up Edit button to increase the values of the flashing digit. The digit steps one unit with each press (0 follows 9). This button can also be used to adjust cut length during normal operation.



Use down Edit button to decrease the value of the flashing digit. This button can also be used to adjust cut length during normal operation.



Use left Move button to select the digit to the left of the flashing digit. The new digit flashes, indicating it can be edited.



Use right Move button to select the digit to the right of the flashing digit. The new digit flashes, indicating it can be edited.

NOTE: You must press the Set button first before the arrow buttons. Press the Set button again after using the arrow buttons to enter the new data.

The Cutter Status buttons and lights provide information about the status of the cutting process:

- **Start Cutter button** enables the drive.
- **Stop Cutter button** disables the drive.

The lights above these two buttons let you know the status of the cutter.

- **Cut light** lets you know when a cut output signal is generated during an on-demand mode.
- **Park light** lights when the flag on the cutter head passes the park sensor proximity switch or is given a signal from a simulated blade position that is generated by the drive.
- **Motor light** lights when the Start Cutter button is pushed. It lets you know the DC motor is enabled.

CUTTER CONTROL FEATURES

CONT'D

- **Guard light** lights when all safety devices (including the E-Stop and machine Reset buttons) are in the correct operating positions.
- **Encoder A, B lights** indicate that the digital ring sensor on the puller motor is sensing signal changes.

The Cut Mode button and lights let you select the cut mode, see which cut mode the cutter is in. They include:

- **Select button** lets you choose the cutting mode. Pressing the button moves you through the list of available cutting modes. The cutting mode is active when the light next to it is lit.
- **Timer light** tells you the cutter is in the timer mode. The timer mode uses a timer to produce a cut signal. When a pre-set time is reached, a signal activates a single cut cycle. In timer mode, accuracy depends on the consistency of the belt puller or feeding device. If the speed of the extrudate changes, the length also changes.
- **Product light** tells you the cutter is in the product mode. Product mode uses an electric eye to sense the end of the extrudate and signal a cut. The electric eye is mounted either on a bracket after the downstream cutter bushing, or on the discharge conveyor. If properly set up, this is the most accurate on-demand cutting mode.
- **Encoder Mode light** tells you the cutter is in the encoder mode. Encoder Mode uses a digital encoder to produce a set number of counts per unit of measure of forward extrudate movement. The cut signal is generated when the number of counts equal to the desired length is reached.
- **Flywheel light** tells you the cutter is in the flywheel mode. Flywheel mode is a continuous cutting mode; the blade spins continuously. The speed is set at 750 rpm. NOTE: If the puller speed changes, the cut length will also change. In most cases the puller speed consistency has a larger effect on cut length accuracy than the flywheel speed.

The puller control has several features that allow you to input setup information and monitor pulling process.

PULLER CONTROL AND CUTTER BLADE CONTROL FEATURES

- **Four-digit display**

When programming the control, the four-digit display shows control settings when programming functions are used. During normal operation, it displays either setpoint or actual speed (tach). Both setpoint and actual speed are expressed as either linear speed (fpm or cm/min) or rpm.

- **Speed buttons**

Use the Set Speed button to enter and monitor the setpoint speed. Pressing the Tach button displays the actual speed. When you select one of these, the LED in the corner lights. Either Set Speed or Tach is active at all times. NOTE: The actual speed shown is the average speed. It is updated once every second.

- **Numeric Keypad**

Use the numeric keypad to access control parameters, adjust programming settings and change the setpoint speed.

- **Data Entry buttons**

The Clear button deletes the value showing on the digital display that you have just entered. The Enter button confirms and accepts data values.

- **Scroll buttons**

Use the Up and Down scroll buttons to adjust the active setpoint displayed on the digital display by one engineering unit. These buttons are always enabled.

- **Two-digit display**

The two-digit display shows the active programming code.

- **Code Select button**

Use this button to enter the desired programming code.

- **Code Select LEDs**

The LED next to the code lights when that code is selected. These are not relevant when the Master Scaling format is used.

- **Programming codes**

This table lists the major codes for you to choose. See Appendix, page F-1, for a complete listing of codes.

COMBINATION CONTROL FEATURES

There are five buttons below the Cutter Control and the Puller control. They are:

- **Cutter Power On/Off**
Turn the Cutter Power On/Off to shut down the cutter portion of the combination for blade replacement, etc., without shutting down the puller portion.
- **Machine Reset button**
Use to restart the combination puller/cutter after an emergency stop.
- **E-Stop button**
Press to stop the Combination Puller/Cutter in an emergency.
- **Puller Start button**
Pressing this button energizes the puller portion.
- **Puller Stop button**
Press this button to shut down the puller portion.

Before you start daily operation of the combination puller/cutter, you need to perform preventative maintenance. Necessary maintenance is described in the Maintenance section of this Users Guide, beginning on page 5-1.

BEFORE STARTING



WARNING: Be sure that power to the puller/cutter is OFF when doing any maintenance on the puller/cutter. Follow all safety rules when performing any maintenance on this equipment.

Daily maintenance includes:

- Inspecting the puller belt
- Inspecting the cutter blades
- Inspecting the blade mounting hardware
- Making sure the cutter bushings are properly secured
- Inspecting the closure latch on the knife guard
- Checking alignment with extrusion line
- Performing any floor lock adjustments as needed

These items and weekly, monthly, and semi-annual maintenance procedures are detailed in the Maintenance section of this User Guide.



DANGER: Pinch Hazard!

Never remove or disable safety devices to sustain production. Operating without these devices could lead to hazardous conditions that can cause severe injury. Take all necessary precautions when working around moving parts to prevent body parts and clothing from being pulled into the machine.

POWERING UP

1 Plug in the power cord to restore power after any required maintenance.

2 Turn on the main power.
The cutter control performs its bootup routine. At the end of the bootup routine the displays shows the current total count and the most recent length display.

While the cutter is booting up, perform the next three steps:

3 Make sure the E-Stop button is in the out, extended position. NOTE: If the E-stop is pushed in, the Guard light on the cutter control will not light, even if all other safety features are in the proper positions for operation.

4 Push the blue lighted machine Reset button (on the control panel). The light should turn out.

NOTE: The blue Reset button lights any time power is disconnected, either by pushing the E-stop or turning off power using the disconnect. The puller/cutter won't run if the Reset button is lit.

5 Make sure that the Cut On/Off button is off (i.e. the light should not be lit). If necessary, press the button to turn the light off.

6 Press the green Puller Start button
The green light on the Start Cutter button illuminates.

7 Press the green Start Cutter button
The red light on the Start Cutter button illuminates.

After powering up the combination puller/cutter, you need to program the puller speed.

- 1 Press the Set Speed button.** The numeric keypad is enabled.
- 2 Enter the desired setpoint (in fpm or rpm).**
The display shows the numbers you entered. If necessary, press the Clear button to delete any entry.
- 3 Press the Enter button.**
The control accepts the new setpoint and the puller goes to the new speed at a pre-programmed acceleration rate.

PROGRAMMING THE PULLER SPEED

To program the blade speed:

- 1 Press the Set Speed button.**
The numeric keypad is enabled.
- 2 Enter the desired blade speed**
The display shows the numbers you entered. If necessary, press the Clear button to delete any incorrect entry.
- 3 Press the Enter button.**
The control accepts the new value and return to normal operation. The blade speed goes to the new speed at a pre-programmed acceleration rate.

SETTING THE BLADE SPEED

NOTE: If the value entered is outside the blade speed range for your cutter, the blade speed defaults to either the maximum or the minimum.

CHOOSE THE CUTTING MODE

Choose on-demand modes (Timer, Encoder, Product) for lower-speed cutting and continuous (Flywheel) mode when making more than 250 cuts per minute.

- **Timer Mode** cuts based on time. When the preset time is reached, the cutter control signals the cutter head to rotate and make a cut. If the extrudate delivery speed changes, the length will also change.
- **Encoder Mode** monitors the forward movement of the extrudate and signals a cut based on a set number of counts per foot.
- **Product Mode** uses an electric eye to sense the end of the extrudate and signals a cut.
- **Flywheel Mode** is a continuous cutting mode; you set the speed of the blade.

SETTING THE CUTTING MODE

- 1** Be sure that the **Cut On/Off** button is **OFF**.
- 2** Press the **Select** button to activate the cutting mode you want. A mode is active when the LED next to it is lit. Each time you press Select the control activates the next available mode. Continue pressing the Select button until you get the mode you want. Then go on to the next step.
- 3** Make any **additional entries** required for the cutting mode you have selected. Press the Set button. Use the adjustment arrows to change the number listed on the Length or Time display. Press Set button to return to normal operating mode.
 - **For Timer mode:** Use the Set button and Adjustment arrows to change the time (in seconds, to three decimal places). NOTE: the decimal point cannot be moved.
 - **For Encoder mode:** Use the Set button and Adjustment arrows to change the cut length. If the cut length does not equal the set length, adjust the prescale value (see page 4-14).
 - **For Product mode:** Use the Set button and Adjustment arrows to change the hold-off time. In Product mode, the desired length is set by the electric eye that sense the end and initiate a new cut. To prevent unwanted double cuts, a hold-off (or one-shot) timer is built into the cutter control. After a cut is made, the hold-off time displays in the Display window (in seconds, to three decimal places) and begins counting down to zero. No cutting occurs until the countdown is completed. Make sure the new value is less than the time between cuts. NOTE: 70-80% of the expected time between cuts is recommended.
 - **For Flywheel mode:** Use the Set button and Adjustment arrows to change the cutter blade speed. If you are not sure what blade speed to use, start fast and work your way down to slower speeds. See Appendix: All About Cutter Blades, page B-1.

SETTING THE PRESCALE VALUE

The Encoder mode uses a scale factor (called the prescale value) to compensate for configurations that differ from the standard (a measuring wheel with a 1 foot circumference; a 1200 pulse encoder; and English units of measure). The prescale value is set at the factory for your equipment and typical unit of measurement. However, it may occasionally be necessary to adjust the prescale value.

To check the length of the cut piece:

- 1 Use the Select button to choose the Encoder mode.**
- 2 Press the Set button** and use the Adjustment arrows to set the length equal to 12.00 inches.
- 3 Produce several trial cuts.** Measure the length of these pieces to within your tolerance (usually to the nearest thousandth). If the pieces are not the correct length, you will have to change the prescale value.

NOTE: You can affect the cut length by changing the clamping force on the puller. Increasing the belt tension results in less slippage and longer cut length. Decreasing belt tension results in more slippage and shorter cut lengths.

To adjust the prescale value:

- 1 Make sure you are in encoder mode,** the Cutter On/Off is off, and the Start light is off.
- 2 Quickly press Set twice.** The current prescale value displays in the Display window. "Scale" displays in the Total window.
- 3 Adjust the prescale value** using the Adjustment arrows.

NOTE: the decimal place cannot be moved.

- 4 Continue adjusting and cutting pieces** until the length is within your requirements. The adjustment process is done by trial and error.

NOTE: The cutter must be in the stop position to change the prescale value.

- 5 Press the Set button.** When all modes are set, press the Set button to accept the new values.

CHECKING CUT QUALITY

- 1 Press the Reset/Test button** and observe the movement of the cutter blade. The cutter head makes a single rotation and the blade moves through the cutter bushings without interference.
- 2 Insert a piece of extrudate through the cutter bushings.**
- 3 Press the Reset/Test button.** A single cut is made at the preset blade speed. NOTE: this works even if Cut On/Off is off.
- 4 Inspect the cut.** If necessary, adjust the blade design or blade speed. See All About Cutter Blades, in the Appendix.

If you have not already done so, perform daily maintenance check, power up the puller/cutter, select cutting mode and blade speed, and make a test cut to check cut quality.

Use the slide system to move the cutter as far from the puller as possible:

- 1 Loosen the turnbuckle at the downstream** end of the puller/cutter by turning 1-2 turns clockwise.
- 2 Slide the cutter as far downstream** as it will go.
- 3 Tighten the turnbuckle by turning it** counterclockwise.

When you are satisfied with cut quality, press the Cut On/Off button to illuminate the LED and begin automatic operation.

When the extrudate is running within tolerance, cut it with a knife or saw and feed it through the cutter bushings. Then move the cutter into position with respect to the puller:

- **For flexible products,** the cutter should be very close to the puller.
- **For more rigid products,** allow enough space between the cutter and puller to absorb any shock generated during cutting.

STARTING THE COMBINATION PULLER/CUTTER

MAKING ADJUSTMENTS DURING OPERATION

You can make adjustments to the combination puller/cutter during operation. These adjustments include:

- Making large changes to the puller speed
 - Making large changes to the cutter blade speed
 - Fine-tuning the puller speed
 - Making a manual cut during operation
 - Counting the number of cuts
 - Adjusting the cutter preset values
 - Temporarily stopping cutting
 - Stopping only the cutter
-

MAKING LARGE CHANGES TO THE PULLER SPEED

- 1 Press the Tach button on the puller control.**
The LED in the corner of the Tach button lights. The display shows the actual puller speed, updated every 1-2 seconds.
 - 2 Press the Set Speed button on the puller control.** The LED in the corner of the Set Speed button lights. The numeric keypad is enabled.
 - 3 Enter the desired setpoint (in fpm or rpm).**
If necessary, press the Clear button to delete any errors.
 - 4 Press Enter to accept the new setpoint.**
The new setpoint is displayed.
-

MAKING LARGE CHANGES TO THE BLADE SPEED

- 1 Press the Tach button on the control.**
The LED in the corner of the Tach button lights. The display shows the actual cutter blade speed, updated every 1-2 seconds.
 - 2 Press the Set Speed button on the Cutter Blade Speed control.** The LED in the corner of the Set Speed button lights. The numeric keypad is enabled.
 - 3 Enter the desired blade speed**
(in fpm or rpm). If necessary, press the Clear button to delete any errors.
 - 4 Press Enter to accept the new setpoint.**
The new setpoint is displayed.
-

Use the Up and Down arrows to adjust the setpoint. The setpoint adjusts by one engineering unit each time an arrow is pressed.

- ◆ If the Tach button is active, the actual speed gradually changes to the new value.
- ◆ If the Set Speed button is active, the setpoint changes immediately.

NOTE: *These keys are always enabled to change the active setpoint. Because they provide only slow scroll speeds, use them to make small changes to the puller speed.*

FINE-TUNING PULLER AND CUTTER BLADE SPEED

Perform a manual cut and reset the length by pressing the Reset/Test button at any time during on-demand cutting. Pressing Reset/Test has no effect during continuous cutting.

Pressing Reset/Test when the Cut On/Off button is in the Off position actuates a cut in flywheel.

MAKING A MANUAL CUT

Count the number of cuts by pressing the Total On/Off button. Use the Reset button to return the count to zero. This feature is useful for collecting samples during a production run.

COUNTING THE NUMBER OF CUTS

ADJUSTING CUTTER PRESET VALUES

Press the Set button and use the adjustment arrows to fine-tune a preset cutter value during normal operation:

- **In Timer mode**, adjust the time between cuts.
- **In Encoder mode**, adjust the length.
- **In Product mode**, adjust the hold-off time.
- **In Flywheel mode**, adjust blade speed.

To use the Adjustment arrows:

- **Count up one digit** by pressing and releasing the Up Edit adjustment arrow.
- **Increase the preset more rapidly** by pressing and holding the Up Edit adjustment arrow.
- **Count down one digit** by pressing and releasing the Down Edit adjustment arrow.
- **Decrease the preset more rapidly** by pressing and holding the Down Edit adjustment arrow.

When the arrow is released the display holds the preset for an additional five seconds before returning to display the count in progress. NOTE: While the control allows you to switch cutting modes during operation, this is not recommended.

TEMPORARILY STOPPING CUTTING

Stop cutting temporarily by setting Cut On/Off to off. This allows you to view the cutting blade (through the window) or perform other tasks without shutting down the cutter.

STOPPING ONLY THE CUTTER

You can shut down just the cutter portion of the combination puller/cutter if you need to change or adjust cutter blades:

- 1 Turn Cut On/Off dial to Off to stop cutting** (light is off).
- 2 Press Stop Cutter button to de-energize the DC motor** (light is off).
- 3 Turn Cutter Power On/Off to Off.**
Power is no longer supplied to the cutter portion of the combination puller/cutter. The belt puller will continue running.

Follow the procedures on page 3-6 to change cutter blades.

STOPPING THE COMBINATION PULLER/CUTTER



WARNING: Never use any part of the guard circuit or the rotary disconnect to stop the combination puller/cutter.

This can cause damage to the equipment and injury to personnel. Use the recommended procedure to assure safe stopping.



CAUTION: Always turn Cut On/Off to Off first.

This is especially important in Flywheel mode; otherwise the blade may come to a stop in the extrudate.

To safely stop the combination puller/ cutter:

- 1 Press Cut On/Off button on the Cutter control** to stop cutting (light is off).
- 2 Press Stop Cutter button to de-energize** the DC motor (light is off).
- 3 Remove extrudate from both puller and cutter.**
- 4 Press the red Puller Stop button.**
- 5 Turn the rotary disconnect to the off position.**



WARNING: Never turn off the rotary disconnect first.

Doing so will turn off all power to the unit, and the cutter will not be brought to a controlled stop. For safe stopping, always follow the sequence given above.

- 6 Disconnect the power cord** if it is equipped with a plug on the end.
- 7 Lock out the rotary disconnect.**
- 8 Clean the lubricant reservoir if you are** shutting down the combination puller/cutter for the day.

SHUTTING DOWN THE PULLER/CUTTER

To shut down the combination puller/cutter, perform the stopping procedure listed above. No additional steps are necessary if the combination puller cutter is shut down for short period of time. If the unit is shut down for an extended period of time, puller belts can and do acquire 'set.' If this occurs, let the puller run for 20-30 minutes before use. This should remove any set from the belts.

MAINTENANCE

- **Maintenance Features**5-2
- **Warnings and Cautions**5-2
- **Preventative Maintenance**
 - Schedule**5-4
- **Inspecting Cutter Blades**5-6
- **Inspecting Blade Hardware**5-6
- **Inspecting Cutter**
 - Bushing Screws**5-7
- **Checking the Closure Latch** ..5-7
- **Checking Floor Locks**5-7
- **Replacing Motor Brushes**5-8
- **Adjusting the Cutter**
 - Proximity Switches**5-9
- **Checking Electrical**
 - Connections**5-10
- **Testing Belt Tension**5-12
- **Checking the Belt Gap**5-14
- **Replacing Belts**5-15
- **Checking Torque**5-16

MAINTENANCE FEATURES

The Combination Puller/Cutter needs regular, scheduled maintenance for peak performance. Among the features that require maintenance are:

- Puller belts
- Cutter blades
- Blade mounting hardware
- Cutter bushings
- The knife guard hardware
- Floor locks
- Lubrication
- Optional slide rail system
- Electrical cables, terminals, and control lights
- Equipment alignment

WARNINGS AND CAUTIONS

To maintain the best performance of the Combination Puller/Cutter, it must be cleaned and inspected regularly. Maintenance includes a daily, weekly, quarterly, and semi-annual (every 6 months) schedule.

Use this maintenance schedule as a guide. You may need to shorten the time of the maintenance schedule, depending on how often you use the combination puller/cutter, and the types of material flowing through it. Follow all precautions and warnings when working on the equipment.



WARNING: Improper installation, operation, or servicing may result in equipment damage or personal injury.

This equipment should only be installed, adjusted, and serviced by qualified technical personnel who are familiar with the construction, operation, and potential hazards of this type of machine.

All wiring, disconnects, and fuses should be installed by qualified electrical technicians in accordance with electrical codes in your region.



DANGER: Pinch Hazard!

Never remove or disable safety devices to sustain production. Operating without these devices could lead to hazardous conditions that can cause severe injury. Take all necessary precautions when working around moving parts to prevent body parts and clothing from being pulled into the machine.

WARNINGS AND CAUTIONS



WARNING: Voltage Hazard

This equipment is powered by alternating current, as specified on the machine serial tag and data plate. Do not operate the equipment at power levels other than what is specified on the machine serial tag and data plate.

A properly-sized conductive ground wire from the incoming power supply must be connected to the chassis ground terminal inside the electrical enclosure. Improper grounding can result in severe personal injury and erratic machine operation.

Before performing maintenance or repairs on this product, disconnect and lock out electrical power sources to prevent injury from unexpected energization or start-up. A lockable device has been provided to isolate this product from potentially hazardous electricity.



DANGER: Sharp blades!

Most injuries caused by knife blades occur when the cutter has been turned off. Handle blades with care at all times.



- Always wear cut-resistant gloves when the cutting chamber is open and when handling blades.
- Always lock out the cutter before opening the cutting chamber.
- Always wait until the cutter head has stopped completely before opening the knife guard.

The Combination Puller/Cutter is equipped with several safety devices to ensure safe operation. Never remove or disable these devices to sustain production. Operating without these devices can cause severe injury.

- When the knife guard is opened, the knife guard switch stops the cutter and prevents starting the cutter again.
- Two proximity-type safety switches prevent operation unless the cutter bushings are in place.
- The Cutter Stop button activates a circuit that stops the knife.

PREVENTATIVE MAINTENANCE SCHEDULE

● Daily

- Checking puller belts for wear**
If a belt shows sign of cracks, tears, or other damage, replace it. Follow the steps on page 5-15.
- Checking puller belt tension**
Check the belt tension as described on page 5-12.
- Checking belt gap**
Check the belt gap as described on page 5-14.
- Inspecting cutter blade(s)**
Clean, sharpen or replace as needed (see page 5-6).
- Inspecting the blade mounting hardware**
Check the blade-securing bolt and the holding pins (see page 5-6).
- Inspecting cutter bushing screws**
Check that the cutter bushing screws are secure (see page 5-7).
- Checking the closure latch on the knife guard**
See page 5-7.
- Inspecting unit alignment**
Proper alignment with other equipment on the line is critical for optimum performance. Use a plumb line or laser to check for a straight line from the extrusion die to the cutter bushings.
- Checking floor locks**
See page 5-7.

● Weekly

- Cleaning the blade guard**
Clean out any shavings. Wipe off clear guard.

PREVENTATIVE MAINTENANCE SCHEDULE

● Monthly

- Checking hardware on the knife guard**
Inspect the hardware on the knife guard (fasteners on hinge and the clear blade guard window). Tighten as needed. See page 5-6.
- Checking bushing holder proximity switches**
Inspect the proximity switch set screws. Adjust as needed. See Adjusting the Proximity Switches, page 5-9.
- Cleaning the clear blade guard window**
Clean using glass cleaner or plain water. Other materials may cause premature loss of clarity or crazing.
- Checking the latch**
Inspect the latch on knife guard for wear and proper tension. Readjust or replace as needed.



● Semi-annual (every six months)

- Inspecting electrical terminals**
Check all electrical terminals for tightness; adjust as needed. See Checking Electrical Connections, page 5-10.
- Checking torque on Trantorque coupling device**
Check the tightness (torque) of the Trantorque coupling device with a torque gauge. This device connects the cutter head to the clutch/brake. See Checking Torque, page 5-16.
- Checking all electrical cables**
Inspect all electrical cables for cuts and abrasions. Replace as needed. See page 5-10.
- Inspecting control panel lights**
Check to make sure no LEDs or lights are burned out on the control panel. Replace as needed.
- Checking motor brushes**
Inspect the motor brushes. Replace as needed. See page 5-8.

INSPECTING CUTTER BLADES

Blades become dull over time depending on the material being cut, cut rate, blade speed, and blade material and thickness. Check blades regularly for sharpness as well as scratches, nicks, burrs, and material buildup. Clean, sharpen or replace as needed (see Installing Cutter Blades, page 3-6).

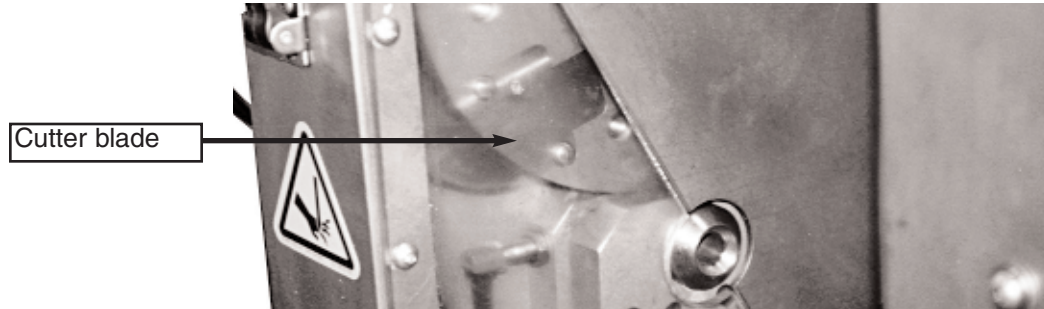

DANGER: Sharp blades!

Most injuries caused by knife blades occur when the cutter has been turned off. Handle blades with care at all times.

- Always wear cut-resistant gloves when the cutting chamber is open and when handling blades.
- Always lock out the cutter before opening the cutting chamber.
- Always wait until the cutter head has stopped completely before opening the knife guard.

INSPECTING BLADE HARDWARE

The blade-securing bolt should use both a lock washer and flat washer, and be tightened enough to fully compress the lock washer. Replace the holding pins if they appear worn.

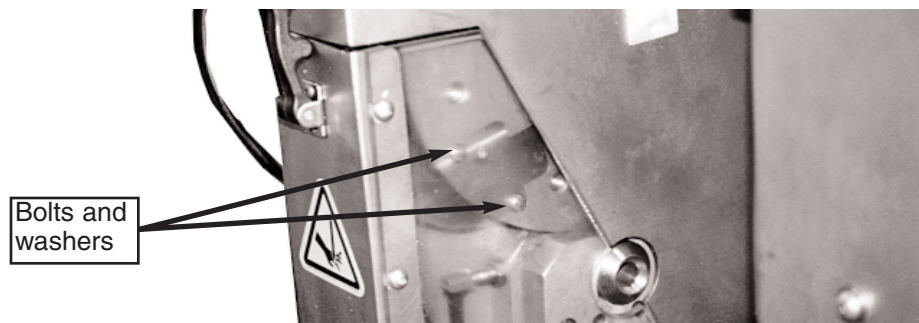

WARNING

Do not operate the combination puller/cutter without washers and blade-securing bolt securely in place.

Check the set screws that secure the cutter bushings. If bushings move during cutting, cutting blades, and possibly the drive chain, could be damaged.

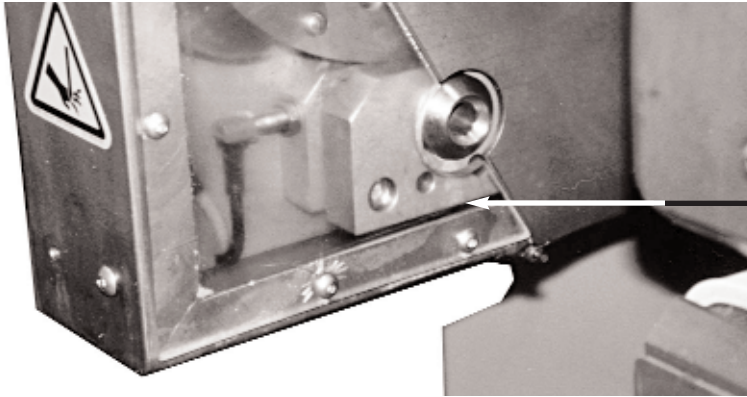

INSPECTING CUTTER BUSHING SCREWS

Cutter bushing screws visible when knife guard is open

Check the latch and adjust it so the knife guard closes completely. This prevents false triggering of the safety switch.

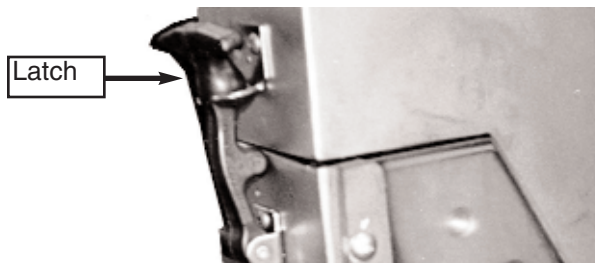

CHECKING THE CLOSURE LATCH

It is best to remove the weight from the casters for optimum stability during cutting cycles. Check to see if the floor locking mechanism is properly adjusted.

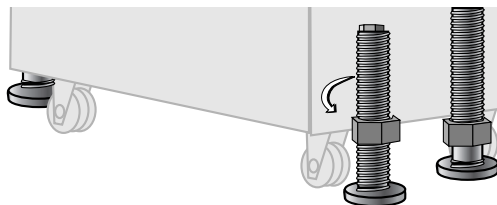

CHECKING FLOOR LOCKS

REPLACING MOTOR BRUSHES

Check the motor brushes. If one or both is less than 1/4 in. long, replace **both** brushes.

To replace the motor brushes:

- 1** Turn the rotary disconnect to the **OFF** position.
- 2** To access the brushes, loosen the screws holding the access covers on each side of the motor housing and remove the covers.
- 3** Remove the spring clips.
- 4** Examine the brushes.
If one or both of the brushes are less than 1/4 in. long, replace **both** brushes.

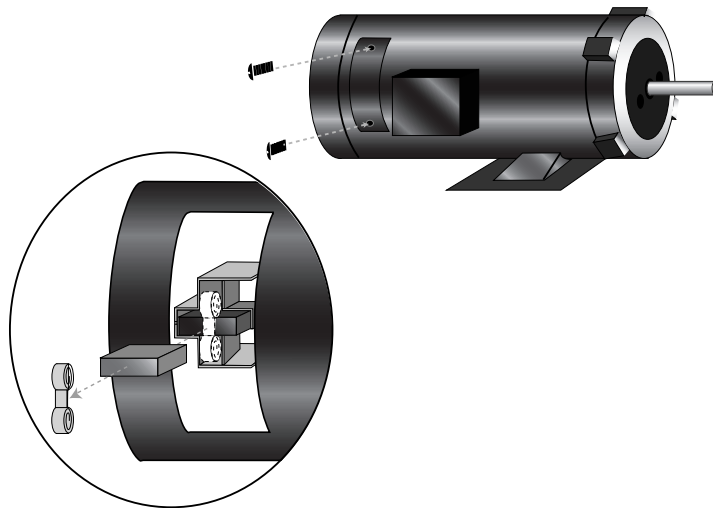

- 5** Replace the covers.

Follow all warnings and cautions listed at the beginning of the Maintenance section of this User Guide.

ADJUSTING THE CUTTER PROXIMITY SWITCHES

- 1** Be sure the main power is disconnected and the cutter is locked out.
- 2** Loosen the set screws that hold the cutter bushings.
- 3** Remove the cutter bushings.
- 4** Check the depth of the proximity switch face for each bushing. It should be recessed no more than 0.010 inches, but should not interfere with the bushings themselves.
- 5** Use an Allen wrench to check the tightness of each proximity switch's retaining screw.

NOTE: You can damage the proximity switch if you over-tighten the retaining screw.

- 6** Replace cutter bushings and check for proper cutting blade alignment. See page 3-7, Mounting the Cutter Bushings, and the Appendix, see page C-1.
- 7** Plug in the power cord and turn the main power disconnect to the on position if all other maintenance is completed.

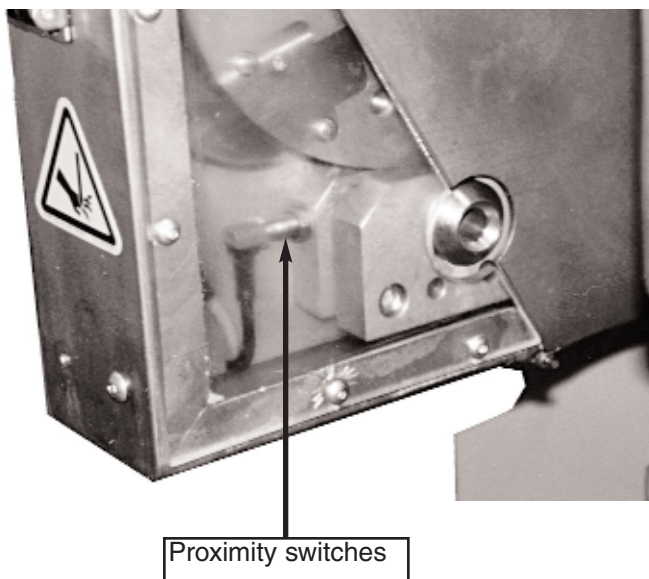

CHECKING ELECTRICAL CONNECTIONS



WARNING: Electrical hazard

Before performing any work on this product, disconnect and lock out electrical power sources to prevent injury from unexpected energization or start-up. A lockable device has been provided to isolate this product from potentially hazardous electricity.



WARNING: Improper installation, operation, or servicing may result in equipment damage or personal injury.

This equipment should only be installed, adjusted, and serviced by qualified technical personnel who are familiar with the construction, operation, and potential hazards of this type of machine.

All wiring, disconnects, and fuses should be installed by qualified electrical technicians in accordance with electrical codes in your region. Always maintain a safe ground. Do not operate the equipment at power levels other than what is specified on the machine serial tag and data plate.

- 1 Be sure the main power is disconnected and the cutter is locked out.** Always disconnect and lock out the main power source before opening the unit or servicing.
- 2 Turn the main power disconnect to the off position** before opening the electrical enclosure on the back of the cutter, or the back of the control. This is a safety device to prevent you from opening the doors if the power is still on.

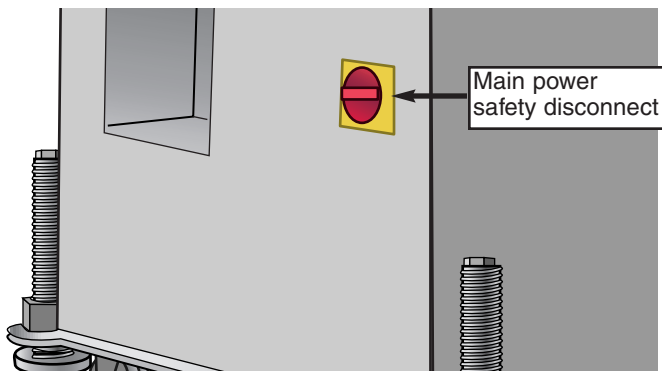

3 **Open the electrical enclosure.**

4 **Inspect all wires and connections.** Look for loose wires, burned contacts, and signs of over-heated wires. Have a qualified electrician make any necessary repairs or replacements.

5 **Close the electrical enclosure door.**

6 **Inspect the exterior power cords.** Cords should not be crimped, exposed, or rubbing against the frame. If the main power cord runs along the floor, make sure it is not positioned where it could rest in pooling water or could be run over and cut by wheels or casters.

TESTING BELT TENSION

1 Turn the main power disconnect to the off position.

2 Remove the upper and lower belt guards:

- Remove the screws attaching guards to unit.



3 Check belt tension.

Use a tension-measuring tool.

Belts should be just tight enough to prevent slipping, and the gap between the upper and lower belts should be even across the width of the belt.

NOTE: It is important to have the proper belt tension. Loose belts result in belt and product slippage; over-tightened belts result in distorted product and can lead to premature bearing failure.

4 Adjust belt tension, if necessary.

Adjust tension by turning the threaded tension rods. Keep tension on front and back edges, top and bottom belts as even as possible:

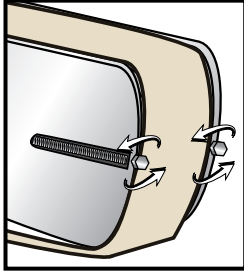

5 Fine tune tension:

- **Lower the belts to a gap of about 1/8" (3mm).**
(See Setting Belt Gap, page 3-9.)
- **From the upstream end of the belts,**
look down the length of the belts at the gap between the belts. If the gap is not even, adjust the tension until the gap is even and measures 1/8". The shape of the gap should not be concave (over-tightened) or convex (too loose).
- **Check tension and readjust as necessary.**

CHECKING THE BELT GAP

The belt gap is the distance from one belt to the other at the surface where the belts pull material. The gap is adjusted by raising/lowering the upper and lower belt boom assemblies. The upper and lower belt boom assemblies are controlled by a common threaded rod. Turn the hand wheel to move the belt boom assemblies up and down until the the belt gap is where you want it.

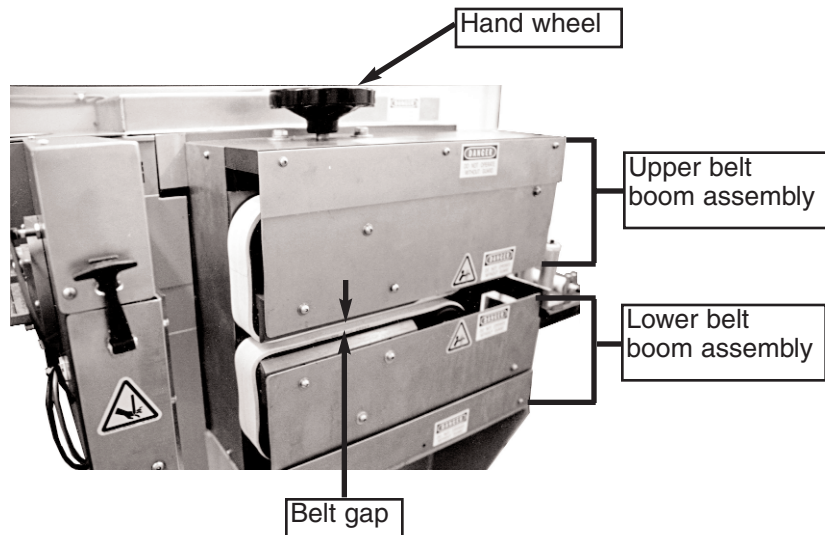

REPLACING BELTS

To replace puller belts:

- 1 Turn the rotary disconnect to the OFF position.**
- 2 Remove the upper and lower belt guards.**
- 3 Release belt tension** by loosening the threaded rods. Keep tension on front and back edges as even as possible by turning each rod 5-10 revolutions, then switching to the other side. Continue until the belt is loose enough to slide off the puller.

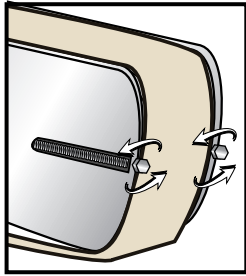

- 4 Remove the belt from the puller.** Check the rollers and pulleys for buildup, especially inside grooves. Clean if necessary.
- 5 Reverse the process to install the new belt.** Make sure ribs inside the belt fit properly into grooves, and keep tension on front and back sides as even as possible by alternating between the two threaded rods.
- 6 Adjust belt tension and belt gap.** Follow the steps starting on page 5-12.

CHECKING TORQUE



WARNING: No lubricants!

Do NOT use lubricants on the Trantorque coupling device.



DANGER: Sharp blades!

Always wear cut-resistant gloves when the cutting chamber is open and when handling blades. Never open cutting chamber without locking out the cutter power and waiting until the cutter head has stopped completely. Handle blades with care at all times.



The Trantorque coupling device connects the clutch/brake to the cutter head. It is important that it is tightened to the proper torque.

- 1** Carefully remove the cutter blade.
- 2** Check to make sure both the **shaft and component bore** of the Trantorque coupling device are completely free of paint, grease, oil, and dirt. If necessary, clean the surfaces with a non-petroleum based solvent, such as isopropyl alcohol.
- 3** Use a **torque wrench** to make sure the nut is tightened to the proper installation torque. Do not overtighten; it can cause damage to the unit.

TROUBLESHOOTING

- *Before Beginning*6-2
- *A Few Words of Caution*6-2
- *Identifying the Cause of a Problem*6-4
- *Puller Operation Problems*6-5
- *Cutter Operation Problems*6-7
- *Product Quality Problems*6-11

REPAIR

- *Restoring Default Memory Settings*6-16
- *Restoring User-Specific Memory Settings*6-16
- *Replacing Safety and Proximity Switches*6-17
- *Adjusting the Proximity Switches*6-18
- *Checking the Motor/ Clutch Brake Assembly*6-19
- *Testing Repeatability*6-20
- *Results of Repeatability Testing*6-21

BEFORE BEGINNING

You can avoid most problems by following the recommended installation, operation and maintenance procedures outlined in this User Guide. If you have a problem, this section will help you determine the cause and tell you how to fix it.

Before you begin troubleshooting:

- Find any wiring, parts, and assembly diagrams that were shipped with your equipment. These are the best reference for correcting a problem. The diagrams will note any custom features or options not covered in this User Guide.
- Verify that you have all instructional materials related to the puller. Additional details about troubleshooting and repairing specific components are found in these materials.
- Check that you have manual for other equipment connected in the system. Troubleshooting may require investigating other equipment attached to, or connected with the puller.

A FEW WORDS OF CAUTION



WARNING: Improper installation, operation, or servicing may result in equipment damage or personal injury.

This equipment should only be installed, adjusted, and serviced by qualified technical personnel who are familiar with the construction, operation, and potential hazards of this type of machine.

All wiring, disconnects, and fuses should be installed and adjusted by qualified electrical technicians in accordance with electrical codes in your region. Always maintain a safe ground. Do not operate the equipment at power levels other than what is specified on the machine serial tag and data plate.



WARNING: Electrical hazard

Before performing maintenance or repairs on this product, disconnect and lock out electrical power sources to prevent injury from unexpected energization or start-up. A lockable device has been provided to isolate this product from potentially hazardous electricity.



DANGER: Sharp blades!

Most injuries caused by knife blades occur when the cutter has been turned off. Handle blades with care at all times.



- Always wear cut-resistant gloves when the cutting chamber is open and when handling blades.
- Always lock out power to the cutter before opening the cutting chamber.
- Always wait until the cutter head has stopped completely before opening the knife guard.

Combination puller/cutters are equipped with several safety devices to ensure safe operation. Never remove or disable these devices to sustain production. Operating without these devices can cause severe injury.

- When the knife guard is opened, the knife guard switch stops the cutter and prevents starting the cutter again.
- Two proximity-type safety switches prevent operation unless the cutter bushings are in place.
- The Stop button activates a circuit that stops the knife.

A FEW WORDS OF CAUTION

IDENTIFYING THE CAUSE OF A PROBLEM

The Troubleshooting section covers problems directly related to the operation and maintenance of the Combination Puller/Cutter. This section does not provide solutions to problems that originate with other equipment. Additional troubleshooting help can be found in manuals supplied with the other equipment.

The main problems you will see with the Combination Puller/Cutters are:

- **Puller operation problems**, which focus on problems that are clearly related to the pullers mechanical components and electrical control system.
- **Cutter operation problems**, which focus on problems that are clearly related to the operation of the cutter's mechanical components and electrical control system.
- **Product quality concerns**. Extrudate quality problems may be related to Combination Puller/Cutter operation. Of course, other sections of the extrusion line also influence the quality of the extruded product. This section does not provide solutions to problems originating with other equipment on the extrusion line.

Additional troubleshooting help can be found in the documentation manuals included with this User Guide.

Look in this section when either the puller control or motor is not working properly.

PULLER OPERATION PROBLEMS

Symptom	Possible cause	Solution
◆ The puller 'creaks' while running.	The belt is too tight.	Check the belt tension; loosen if necessary. See Maintenance section, page 5-12.
	The bearings are failing.	Replace the bearings.
◆ The puller does not start.	The E-stop button is pushed in.	Pull out the E-stop button. (Make sure it clicks into position.)
	RAM failed.	Contact Conair service.
◆ Controller stopped during power-up PROM test. '□.□.□.□' displays in the digital display.		
◆ Controller stopped during power-up RAM test. A number displays in the digital display.	PROM checksum comparison failed.	Contact Conair service.
◆ Motor does not stop.		Check programming code 53. Refer to M-Trim User Manual, chapter 9.
◆ Motor does not run.		Check programming code 53. Refer to M-Trim User manual, chapter 9.

PULLER OPERATION

PROBLEMS, CONT'D

Symptom	Possible cause	Solution
◆ Motor runs at wrong speed.		Refer to M-Trim user manual, chapter 9.
◆ Motor at correct (set) speed, but not fast enough for the extrusion line.	Maximum rpm incorrectly set.	Check programming code 11. Refer to M-Trim user manual, chapter 9.
◆ Motor at correct (set) speed, but not slow enough of the extrusion line.	Minimum rpm incorrectly set.	Check programming code 10. Refer to M-Trim user manual, chapter 9.
◆ Motor seems unstable.		Check PID tuning. See Appendix, section F.
◆ Tach reads incorrectly.		Refer to M-Trim user manual, chapter 9, item 8.
◆ Display shows ---1, ---2, or ---3.	Electrical noise is reaching controller.	Check control parameters against desired values. If values have changed, restore the original settings. See Restoring Memory Settings. page 6-16.

Look in this section when the cutter control is not working properly.

CUTTER OPERATION PROBLEMS

Symptom	Possible cause	Solution
<p>◆ The lighted Reset button does not go out when pressed.</p>	The E-stop button is pushed in.	Pull out the E-stop button.
	Guard light not illuminated.	<p>Check to see if:</p> <ul style="list-style-type: none"> <input type="checkbox"/> The blade guard is closed. <input type="checkbox"/> Master Control relay (MCR) has failed. Replace relay.
	A safety switch has failed.	Check connections and replace if needed.
<p>◆ Pressing Start Cutter had no effect. The LED in the corner does not light and “Guard Error” displays.</p>	There is a loose connection.	Check wiring between cutter control and the relay.
	The relay is bad.	Repair or replace the relay.
	The guard circuit failed.	Check guard circuit, repair or replace components.
<p>◆ Pressing the Reset/Test button does not produce a cut when in an on-demand mode.</p>	There is a loose connection.	Check wiring and tighten connection.

CUTTER OPERATION

PROBLEMS, CONT'D

Symptom	Possible cause	Solution
◆ Guard LED on cutter does not illuminate.	Guard circuit is open.	Check to see if: <ul style="list-style-type: none"><input type="checkbox"/> The blade guard is closed.<input type="checkbox"/> Loose connection to guard circuit. Tighten connection.<input type="checkbox"/> Guard switch is bad. Replace switch.
◆ Encoder A, B LEDs do not light.	Input from encoder failed.	Check encoder cable for continuity. Connect any loose wires.
	Encoder failed.	Replace encoder.

CUTTER OPERATION PROBLEMS, CONT'D

Symptom	Possible cause	Solution
<p>◆ In encoder or timer modes, the display shows the count which resets, but a cut does not occur at the point of reset.</p>	<p>There is a problem with the cutter control.</p>	<p>Check for control output.</p>
	<p>There is a loose connection.</p>	<p>Check wiring for loose connections.</p>
<p>◆ Cutter control displays “Blade error”.</p>	<p>There is an anti-jam circuit signal.</p>	<p>This error appears when the blade does not go through the cut cycle in the required time.</p> <p>Check for:</p> <ul style="list-style-type: none"> <input type="checkbox"/> Loose connection on cutter control. <input type="checkbox"/> Blade is stuck in extrudate/bushings.
<p>◆ Cutter control displays “Blade error”.</p>	<p>There is a problem with the home proximity switch.</p>	<p>See Adjusting the Proximity Switches, page 6-18.</p>
	<p>There is a problem in the guard circuit.</p>	<p>Make sure the E-stop and Reset buttons are in the correct operating positions. Check guard circuit for loose connections or bad switches. Replace if necessary.</p>

CUTTER OPERATION

PROBLEMS, CONT'D

Symptom	Possible cause	Solution
◆ Cutter mode selection does not change cut mode.	There is a communication failure between the control and drive.	Check wiring for loose connections and tighten.
◆ The park position is erratic.	The home proximity switch is bad.	Replace the proximity switch.
	The home proximity switch is not properly gapped.	See Adjusting the Proximity Switches, page 6-18.

Look in this section when the final product does not meet quality standards.

PRODUCT QUALITY PROBLEMS

Symptom	Possible cause	Solution
◆ Annular rings present on the extrudate.	The belt puller is too close to the cutter.	If the extrudate is interrupted (stopped during processing), annular rings can develop, especially on a thin-walled product. Slightly increase the distance between the puller and the cutter, and test the product until the distance is correct.
	The bushings do not provide enough support during cutting.	Change bushing design to make more supportive.
	The bushing gap is too wide.	Check that bushing gap is 0.001-0.003 in. larger than blade. Adjust if necessary.
◆ Burrs at cut site.	The blade speed is too low.	Increase blade speed or decrease the cut path area.
	The blade is too thick.	Use a thinner blade or add heat to extrudate.

PRODUCT QUALITY PROBLEMS, CONT'D

Symptom	Possible cause	Solution
◆ Hairs or strings.	Blade speed is too low.	Increase the blade speed or decrease the blade cut path area (blade width).
	The blade is too thick.	Excessive blade thickness can cause frictional heat. Use a thinner blade.
	The blade is wrong for the application.	Change angle of the blade attack or the blade style to decrease the cut path area.
	Material is building up on the blade and wiping off on the cut site.	Use blade lubrication (water, etc.) or change lubricants. See Appendix, page D-1. Consider a blade wiping system.
	There are imperfections on the blade.	The cutting edge should not have grind marks, burrs or other imperfections. Check the blade and replace if necessary.
	A hole or slot in the blade cut path is causing a 'cheese grater' effect.	Change to a different blade design. See pages B-1 through B-6.
	The extrudate is too cold.	If the extrudate is too cold, it can fracture during cutting. Raise the extrudate's temperature.

PRODUCT QUALITY PROBLEMS, CONT'D

Symptom	Possible cause	Solution
◆ Cracks at cut site.	The extrudate is too cold.	If the extrudate is too cold, it can fracture or whiten during cutting. Raise the extrudate's temperature.
	The blade speed is too high.	High blade speeds can cause too much impact. Lower the blade speed.
	The bushings are not providing enough support during cutting.	Change the bushing design to make them more supportive.
	The cutting blade is too sharp.	A blade that is too sharp can fracture some materials, especially rigid PVC and nylons. Slightly dull the blade.
	If using Nylon, it may be cooling too quickly.	If nylon is cooled too quickly, its molecular structure may become unstable, leading to poor physical properties. Try more gradual cooling.

PRODUCT QUALITY PROBLEMS, CONT'D

Symptom	Possible cause	Solution
◆ Cut is not square.	The blade speed is too low.	Low blade speeds can cause excessive blade interruption. Increase blade speed or decrease the blade cut path area.
	The blade is misaligned.	Check that blade is 90 degrees relative to the bushing holder.
	The cutter bushings are not properly gapped.	If the cutter bushings are not properly gapped, the blade may be free to move with the extrudate. Check and adjust if necessary. See pages 3-7 and C-1.
	The knife bevel is not symmetric.	If the knife bevel is asymmetric, the blade will tend to move in the direction of the smaller bevel. Be sure that the bevel is symmetric. NOTE: You can use this to your advantage with some rigid products.
	For rigid products the puller is too close to the cutter.	There must be enough space between the puller and cutter to allow for the extrudate to stop during cutting.

PRODUCT QUALITY PROBLEMS, CONT'D

Symptom	Possible cause	Solution
◆ Length of cut is incorrect.	Repeatability is wrong.	Test for repeatability. See pages 6-20 and 6-21.
	Encoder, input device problem.	Check encoder, input device and clean. Run repeatability test (see pages 6-20 and 6-21).
	There is a problem with the puller.	Run repeatability test (see pages 6-20 and 6-21).

RESTORING DEFAULT MEMORY SETTINGS



WARNING

This procedure restores the M-Trim control to the factory default settings. Any user-entered parameters or programming will be erased.

To restore default memory settings to the puller control or the cutter speed control:

- 1 Turn OFF power to the device.**
- 2 While simultaneously pressing** the Clear and the 7 on the numeric keypad, turn the power ON.

- ◆ The factory default settings are restored. The M-Trim control performs the power up routine described in the Operation section, Powering Up, page 4-10.

RESTORING USER-SPECIFIC MEMORY SETTINGS

Set any user-specific memory settings after you have restored the default memory settings. Using the Control Settings found on the tables starting on page F-1 restore your control to its normal operating state:

- 1 Open the flap** at the bottom of the M-Trim control.
- 2 Press the Control Select button.**
- 3 Enter the desired two-digit code number** (from the tables beginning on page F-1).
- 4 Press the Enter button.**

- ◆ The two-digit code displays in the lower digital display.
- ◆ The current parameter value displays in the upper digital display.
- ◆ The numeric keypad is enabled.

If necessary, use the numeric keypad to enter a new value.



CAUTION

Press the Enter button within 10 seconds to accept the new number. Otherwise the parameter reverts to the previous value.

REPLACING SAFETY AND PROXIMITY SWITCHES

Three safety switches are included on cutter: a keyed safety switch on the knife guard, and a proximity switch on each cutter bushing. A failure in any of these switches prevents the puller/cutter from running.

● Safety Switch

If you suspect a problem with the keyed safety switch on the knife guard, check for loose or damaged wires. Replace the switch if wires appear to be undamaged.

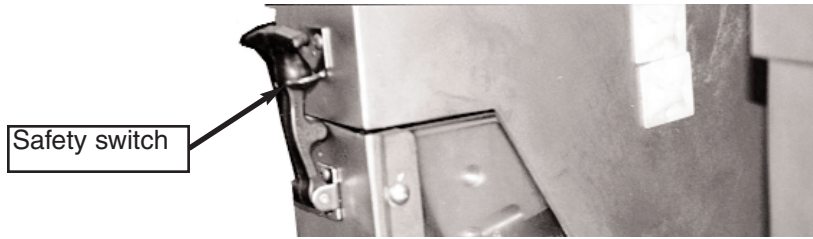

● Proximity Switches

The proximity switches on the cutter bushings have LEDs that light when the bushing is sensed. If an LED does not light when the bushing is in place:

- 1 Check for loose or damaged wires.**
- 2 Remove the cutter bushing** and make sure the proximity switch is properly positioned, i.e. 0.010" from the bushing surface.

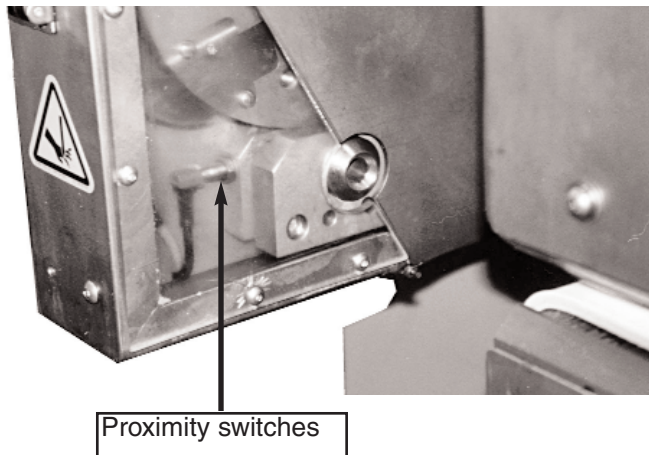

- 3 Remove the proximity switch** by loosening the set screw. Test it by bringing an object close to the sensor when the power is turned on. If the LED does not light, replace the proximity switch.

ADJUSTING THE PROXIMITY SWITCHES

The home position proximity switch should be 0.010" from the 5/16" thread rod on the cutter head for proper operation.

- 1 Open the knife guard.**
- 2 Locate the 1/4" thread rod on the cutter head.**
It should be 0.010" from the proximity switch sensor when it passes that location. If necessary, loosen the jam nuts, readjust the distance, and re-tighten the jam nuts.



DANGER: Sharp blades!

Always wear cut-resistant gloves when the cutting chamber is open and when handling blades. Never open cutting chamber without locking out the cutter power.

Most injuries caused by knife blades occur when the cutter has been turned off. Handle blades with care at all times.

- 3 If the proximity switch does not sense** the cutter head after this adjustment, remove the switch and test it outside the cutter. Replace if necessary.

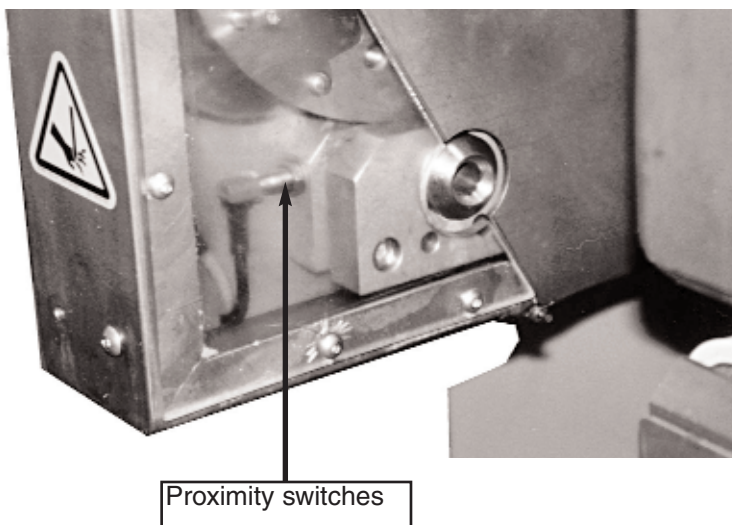

-
- 1** Open the knife guard.
 - 2** Remove the cutter head by loosening the Trantorque assembly. Refer to the manufacturer's guide included with this User Guide for information about the Trantorque assembly.
 - 3** Locate the bolts holding the clutch/brake and DC motor assembly to the cutter. Remove them and carefully remove the assembly from the cutter.
 - 4** Refer to the clutch/brake installation and maintenance information included with this User Guide to check and adjust the clutch/brake and motor assembly.

CHECKING THE MOTOR/CLUTCH BRAKE ASSEMBLY

TESTING

REPEATABILITY

Before any Conair puller/cutters are shipped, they are tested for cut time repeatability to be sure they are within performance specifications. The repeatability test checks the performance of the rotary knife cutter to return the home park position after a complete cut. Acceptable repeatability time for the DC pneumatic cutter is less than 1.5 millisecond. (One millisecond at 60 feet per minute is equal to 0.012 inches.)

The repeatability mode is built into the Conair cutter controls and allows you to perform similar tests, without any external test equipment. It is recommended that you check repeatability on a regular basis. Acceleration/deceleration delays of the optional servomotor do not contribute to repeatability error; any error is attributed solely to motor stability, couplings, assembly, power, and proximity sensor alignment.

Use any blade speed and line speed. The Line speed is only seen while in the Encoder or Product modes. It is recommended that the tests be performed at cut intervals between 0.5 and 5-seconds. Do not change the blade speed or the line speed after starting the test.

To test repeatability:

- 1 Turn on the cutter.** Performing the test with the cutter off-line shows problems with the cutter; performing the test with the cutter on-line shows a problem with the puller.
- 2 Place the cutter in any mode.**
- 3 Press the Cut On/Off button;** the cutter is activated automatically.
- 4 Press and hold the Move Right button** for a minimum of 5 seconds.
- 5 Read the results on the display.**



Repeat the test by pressing the Reset/Test Cut button to begin a new sample period.

To end the Repeatability test, press any button except the Reset/Test Cut button. The LED returns to its normal display.

RESULTS OF REPEATABILITY TESTING

Results in Flywheel mode

The display shows "Repeat Test" and the park-to-park (PP) reading. This is the total (peak) variance of a full revolution of the cutter head. The reading is in milliseconds, to the third decimal place, i.e. 0.010 is 0.01 milliseconds (or 10 microseconds). If the reading exceeds 9.999 the unit automatically resets the repeatability test, displays "Over Run", and attempts to begin the test again. If this occurs the error is too large and there is a fault in the cutter drive that must be corrected.

Results in Timer mode

When testing repeatability in Timer mode, the cutter is making on-demand cuts at a set time interval (i.e. one-second intervals). The display shows "Repeat Test", and then the cut-to-park (CP) reading and the cut-to-cut (CC) reading. The reading is in milliseconds, to the third decimal place, i.e. 0.010 is 0.01 milliseconds (or 10 microseconds).

CP is the peak time variance between the cut signal output (preset time) and the proximity switch just prior to the end of the cut cycle. This is the repeatability of the cutting system to return to the home park position. This value is higher than the PP reading since it includes the acceleration and deceleration contributed by the DC motor or clutch/brake.

CC is the peak time variance between cuts. Record and compare the cut-to-cut number to the CC value recorded in encoder or product mode shows how much error is by external influences (i.e. variation in belt puller speed, encoder mounting problem, etc.).

If the reading exceeds 9.999, the unit automatically resets the repeatability test, displays the message "Over Run", and attempts to begin the test again. If this occurs the error is too large and there is a definite fault that must be corrected.

Results in Encoder or Product mode

The display shows "Repeat Test", and then the cut-to-park (CP) reading and the cut-to-cut (CC) reading. The reading is in milliseconds, to the third decimal place, i.e. 0.010 is 0.01 milliseconds (or 10 microseconds).

Compare the cut-to-park (CP) reading to the CP reading in the other modes. There should be very little difference in these readings.

Compare the cut-to-cut (CC) reading to the CC reading in the other modes. Since the Encoder and Product modes are influenced by external signals, this reading will reflect the speed stability of the puller.

Conair has made the largest investment in customer support in the plastics industry. Our service experts are available to help with any problem you might have installing and operating your equipment. Your Conair sales representative also can help analyze the nature of your problem, assuring that it did not result from misapplication or improper use.

To contact Customer Service personnel, call:



From outside the United States, call: 814-437-6861

You can commission Conair service personnel to provide on-site service by contacting the Customer Service Department. Standard rates include an on-site hourly rate, with a one-day minimum plus expenses.

If you do have a problem, please complete the following checklist before calling Conair:

- Make sure you have all model, serial and parts list numbers for your particular equipment. Service personnel will need this information to assist you.
- Make sure power is supplied to the equipment.
- Make sure that all connectors and wires within and between the cutter and related components have been installed correctly.
- Check the troubleshooting guide of this manual for a solution.
- Thoroughly examine the instruction manual(s) for associated equipment, especially controls. Each manual may have its own troubleshooting guide to help you.
- Check that the equipment has been operated as described in this manual.
- Check accompanying schematic drawings for information on special considerations.

WE'RE HERE TO HELP

HOW TO CONTACT CUSTOMER SERVICE

BEFORE YOU CALL ...

Additional manuals and prints for your Conair equipment may be ordered through the Customer Service or Parts Departments for a nominal fee.

EQUIPMENT GUARANTEE

Conair guarantees the machinery and equipment on this order, for a period as defined in the quotation from date of shipment, against defects in material and workmanship under the normal use and service for which it was recommended (except for parts that are typically replaced after normal usage, such as filters, etc.). Conair's guarantee is limited to replacing, at our option, the part or parts determined by us to be defective after examination. The customer assumes the cost of transportation of the part or parts to and from the factory.

PERFORMANCE WARRANTY

Conair warrants that this equipment will perform at or above the ratings stated in specific quotations covering the equipment or as detailed in engineering specifications, provided the equipment is applied, installed, operated and maintained in the recommended manner as outlined in our quotation or specifications.

Should performance not meet warranted levels, Conair at its discretion will exercise one of the following options:

- Inspect the equipment and perform alterations or adjustments to satisfy performance claims. (Charges for such inspections and corrections will be waived unless failure to meet warranty is due to misapplication, improper installation, poor maintenance practices or improper operation.)
- Replace the original equipment with other Conair equipment that will meet original performance claims at no extra cost to the customer.
- Refund the invoiced cost to the customer. Credit is subject to prior notice by the customer at which time a Return Goods Authorization Number (RGA) will be issued by Conair's Service Department. Returned equipment must be well crated and in proper operating condition, including all parts. Returns must be prepaid.

Purchaser must notify Conair in writing of any claim and provide a customer receipt and other evidence that a claim is being made.

WARRANTY LIMITATIONS

Except for the Equipment Guarantee and Performance Warranty stated above, Conair disclaims all other warranties with respect to the equipment, express or implied, arising by operation of law, course of dealing, usage of trade or otherwise, including but not limited to the implied warranties of merchantability and fitness for a particular purpose.

Cutter blade characteristics such as material, design, and thickness can have a large effect on cut quality.

Blade materials

Blue tempered spring steel is most commonly used because of its cost and availability over a wide range of thicknesses (0.010-0.062 inch). It is a very tough material with an HRC value of approximately 48-51 and fair wear characteristics.

Razor blade stainless steel is becoming very popular due to its HRC value of 57-58, which leads to improved wear resistance. This material retains good toughness, but will chip or break. It is available in 0.010-0.062 inch thicknesses. Because it is non-corrosive, stainless steel is a good choice for medical cutting applications, and may even be coated with Teflon to enhance cut quality.

A-2 is a good grade of tool steel with an HRC of 60. Its minimum thickness (0.031 inch) forces the blade manufacturer to grind it down for thinner applications, which adds cost. A-2 is more wear resistant than stainless, but is also more brittle.

M-2 is an excellent grade of tool steel with an HRC of 63-66. It is one of the best materials for coating with titanium nitride for improved wear resistance. (However, coatings generally cause some slight loss of sharpness.) 0.025 inch material is available, which covers many applications without the need for secondary grinding operations.

D-2 is another excellent tool steel with an HRC range of 58-60. It is tougher than M-2 but has slightly less wear resistance. Its minimum thickness (0.035 inch) and the need for specialized grinding materials, make it a relatively expensive material. It is the material of choice for cutting Kevlar-reinforced hose.

CPM 10-V is a form of carbide developed especially for the high speed punch industry. With an HRC of 60-62 and a toughness that far exceeds D-2, it is by far the best cutting blade material. Because its minimum thickness is 0.035 inch, and it requires the use of diamond grinding wheels, CPM 10-V is the most expensive of the blade materials.

CUTTER BLADE SELECTION AND USE

CUTTER BLADE SELECTION AND USE

Blade Design

Straight-edge knives have a straight cutting surface. A chopping action (which has cutting forces parallel to the cut) is typically obtained with straight-edge blades.

Because the blade is mounted on a rotary arm, some slicing action (which has additional force vectors at various angles to the cutting edge) is obtained, but generally not through the entire cutting action. If a slicing action is required, the angle of attack can be modified by mounting the blade on a 30-45 degree angle as close to the cut site as possible. In many cases the bushings must be modified to allow the blade holder to have close proximity to the cut site. This offers the steepest angle of attack throughout the entire cutting process.

Generally straight knives can be obtained in thicknesses from 0.004-0.060 inch depending on the application.

Curved-edge knives offer increased slicing throughout the entire cutting action. They are generally used for cutting rubber preforms, rubber hose, flexible foams, and other materials that require slicing. Blade lubrication is often used to enhance the cut and minimize blade and bushing buildup.

As a general rule, curved-edge knives offer improved cut quality on rigid materials if additional heat can be used. However if used on cold rigid materials, curved knives have a tendency to produce wavy or angled cuts.

A curved edge knife can sometimes cut larger cross section profiles and tubing with the same horse power as a straight edge blade. However, the use of a curved blade increases product interruption. To overcome this effect, use a variable speed rotary knife cutter to vary the blade speed to obtain the desired cut quality.

Piercing blade (bat-wing, woodpecker) knives are specifically designed for cutting thin wall tubing. Their shape minimizes penetration marks caused by the flattening action of the blade prior to penetration of the extrudate. These are the most expensive type of blade, and the most susceptible to breakage. Because the point is exposed and not fully supported by the bushings, it may deflect into the bottom of the bushing bore and break off. For these reasons, piercing blade knives are usually used as a last resort.

Some rigid materials require warming when this type of blade is used because the impact of the point can cause cracking or whitening.

CUTTER BLADE SELECTION AND USE

Blade thickness

Because material is displaced rather than removed in rotary knife cutting, think of the blade as a wedge. The thicker the blade, the greater the displacement. This displacement can cause fracture in rigid profiles and tubing, which is often observed as a whitening on all or a portion of the cut. You can reduce this fracturing by reducing the thickness of the blade.

(This effect can also be minimized by heating the profile or tube. However, if heat is used to enhance cut quality, the bushings must be supportive enough to minimize distortion.)

If the cutting blade is too thin, it may actually deflect within the bushing bore. This can lead to "S" shaped cuts or premature blade breakage.

Optimizing blade speed

Flexible extrudates generally require a very fast blade speed with a slicing action for best results. This is due to the fact that even minimal interruption can cause a blade jam on a product that has little or no internal strength.

On the other hand, rigid extrudates may require different blade speeds to obtain the desired cut quality. What's needed for a particular application depends on blade style, internal heat, and blade thickness. Speeds as slow as 300 rpm may be required if a curved blade is used with little or no heat.

Improving cut quality by adding heat to certain materials

All rigid extrudates can have their cut quality improved by the addition of heat. A few of the most common materials and the respective temperatures are listed below:

Rigid PVC	110°-125° F
Styrene ABS	120°-135° F
Polypropylene	160°-200° F

It is important to remember that as the temperature approaches the glassification zone, the degree of support offered by the bushing becomes more important.

CUTTER BLADE SELECTION AND USE

Calculating Blade Interruption

Blade interruption is the length of time which the blade interrupts the extrudate during the cutting process. Knowing blade interruption allows you to optimize blade speed and design for specific applications.

You can calculate blade interruption for your application if you know:

- the cutting blade width
- blade speed (cutter rpm)
- extrudate cross section.

The rotary knife cut path circumference is fixed for each cutter model.

Calculate the blade interruption time. The interruption time starts when the blade makes its first contact with the extruded material and ends when the blade is totally clear of the product (i.e. no longer interrupting it). Because we know the blade travel speed, we can calculate the interruption time if we know how far the blade travels during period of interruption. This distance is equal to the sum of the extrudate outer diameter and the blade width at the point of contact.

$$\text{Blade interruption time, msec} = \frac{(\text{Product OD} + \text{Blade width})}{\text{Knife circumference}} \times \frac{60,000}{\text{rpm}}$$

CUTTER BLADE SELECTION AND USE

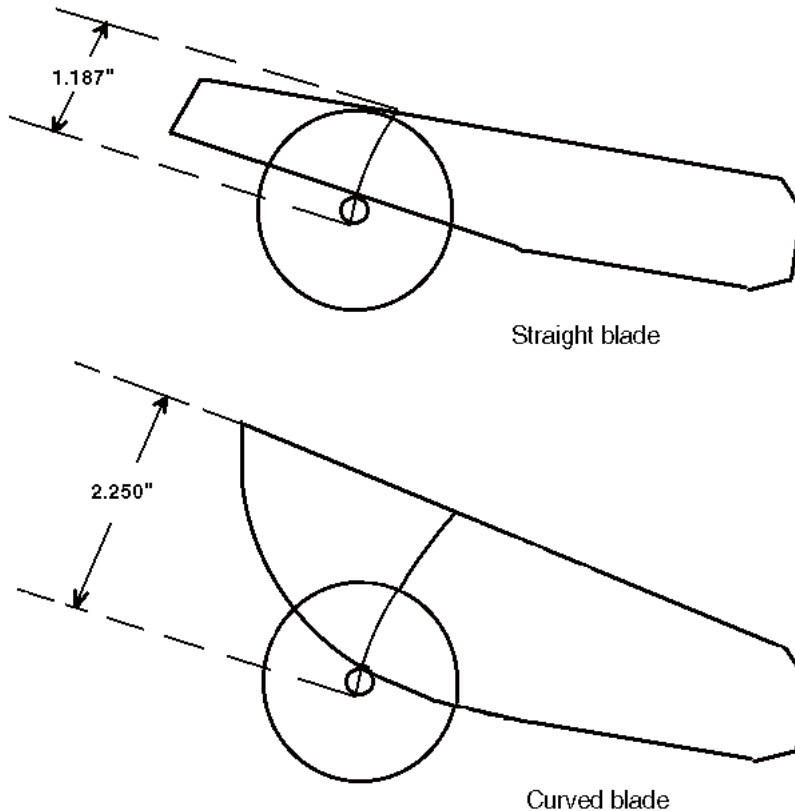

To calculate interruption time:

$$\frac{(0.937 \text{ in.} + 0.250 \text{ in.})}{34.6 \text{ in.}} \times \frac{60,000 \text{ msec/rev}}{718 \text{ rpm}} = 2.87 \text{ msec}$$

Knowing the interruption time and the line speed, you can calculate the amount of production deflection that must be accommodated during cutting. To calculate the amount of extrudate deflection between the cutter and puller, multiply line speed by interruption time:

$$\text{Blade Interruption time, msec} \times \text{Line speed, fpm} \times \frac{12}{60,000} = \text{Deflection, in.}$$

$$2.87 \text{ msec} \times 60 \text{ fpm} \times 12 = .034 \text{ in.}$$

In this example the puller and cutter must be set up to allow for 0.034" of product deflection during cutting. Failure to do this can lead to puller stoppage (which can form annular rings on the product), and poor-quality cuts (hairs or fuzz and angular cuts).

CONAIR CUTTER BLADES

Part No.	Blade Type	Bushing Size	Blade Thickness	Blade Material
3515-30088	Straight	2 inch	0.010 in.	Stainless Steel
3515-30096	Straight	2 inch	0.015 in.	Stainless Steel
3515-30104	Straight	2 inch	0.020 in.	Stainless Steel
3515-30016	Straight	2 inch	0.025 in.	Stainless Steel
3515-30085	Curved	2 inch	0.010 in.	Stainless Steel
3515-30072	Curved	2 inch	0.015 in.	Stainless Steel
3515-30080	Curved	2 inch	0.020 in.	Stainless Steel
3515-30032	Curved	2 inch	0.025 in.	Stainless Steel
3515-30128	Straight	3 inch	0.020 in.	Stainless Steel
3515-30024	Straight	3 inch	0.025 in.	Stainless Steel
3515-30024-1	Straight	3 inch	0.025 in.	Spring Steel
3515-30136	Straight	3 inch	0.032 in.	Stainless Steel
3515-30136-1	Straight	3 inch	0.032 in.	Spring Steel
7130320101	Curved	3 inch	0.015 in.	Spring Steel
7130320102	Curved	3 inch	0.025 in.	Spring Steel
7130320103	Curved	3 inch	0.032 in.	Spring Steel
7130320301	Straight	4 inch	0.025 in.	Spring Steel
7130320302	Straight	4 inch	0.032 in.	Spring Steel
7130320201	Curved	4 inch	0.025 in.	Spring Steel
7130320202	Curved	4 inch	0.032 in.	Spring Steel
7130320501	Straight	5 inch	0.025 in.	Spring Steel
7130320502	Straight	5 inch	0.032 in.	Spring Steel
7130320401	Curved	5 inch	0.025 in.	Spring Steel
7130320402	Curved	5 inch	0.032 in.	Spring Steel

ALL ABOUT CUTTER BUSHINGS

Rotary knife cutter bushings are probably the most ignored aspect of cutting. Yet, they are probably the most important ingredient to obtaining clean, square, accurate cuts with minimal jamming and broken blades.

This appendix contains information about several aspects of cutter bushings:

- bore characteristics
- bushing length
- shear surface characteristics
- the bushing gap

Cutter bushing bore size

The cutter bushing bore size affects both the cutting process and the overall extrusion process.

Bushings with relatively large bores are often used to facilitate start-up and minimize bushing inventory. While this practice is acceptable for start-up, it will lead to premature blade failure because the bushings do not properly support the blade. For optimum cut quality, make sure the bore adequately supports the tube or profile.

When the blade first makes contact with the tube or profile, it pushes the part until it assumes the size and/or shape of the bushing bore. In the case of tubes this causes two marks on the tube (penetration marks) that show where the tube flattened before the blade actually penetrated it. The tighter the bushing bore size to tube size, the closer the marks become, making them less obvious.

If the bushing bore is too tight, excessive extrudate interruption or even jamming may occur. In turn, this can cause internal air blockage in free extruded flexible materials and thus extrudate size fluctuations. In the case of rigid profiles or tubes, belt puller slippage may occur during the cutting if the bushings are improperly configured. This can cause annular rings around the extrudate and size fluctuations.

- For rigid profiles or tubes, allow 0.010-0.020 inch clearance over the OD tolerance. Anything tighter than 0.010 inch will be difficult to process. For easier startup, allow as much as 1/4 inch above a rigid profile because the blade will force the profile to the bottom of the cutting bushing where the shearing action occurs. However, if perfect squareness is required, the clearance above the profile should be minimized to prevent bowing.

ALL ABOUT CUTTER BUSHINGS

Supportive bushings become more important if heat is used to minimize whitening (fracturing).

- If you are cutting a square or rectangular profile, whether rigid or flexible, a round bushing bore will not offer proper support and will often lead to an "S" shaped cut. A flat bottomed bushing will offer excellent support and enhance the shearing action of the blade.
- In the case of flexible extrudates, allow 0.010-0.050 in. clearance depending on durometer and surface; the softer durometers and tacky surfaces require the most clearance. In the case of softer durometer materials, bushing lubrication may be required to minimize drag and material build-up between the cutter bushing faces.

Cutter bushing bore surface quality

The internal surface of the cutter bushing must be smooth and glass-like when cutting flexible extrudates, otherwise excessive drag causes jamming and can lead to variations in cut-to-length accuracy.

- When cutting flexible materials, have the internal surface machined to resemble glass. In many cases, medical processors will actually have the ID of their bushings either honed or burnished for best results.
- When cutting clear extrudates, it is also very important to have a smooth internal surface to minimize scratches. In some cases it may be necessary to make a Teflon or Delrin insert to further minimize drag and/or scratching.
- Bushing lubrication can also help minimize bushing drag.
- Be sure to have a lead-in angle machined into the entrance of the upstream cutter bushing. The transition from the bore to the lead-in angle should not be abrupt as it can cause variable drag.

Cutter bushing shear surface quality

ALL ABOUT CUTTER BUSHINGS

Similar to a dull pair of scissors, if the cutter bushing shear surface is not sharp the tube or profile is not supported to the side of the blade and the cut will not be clean. In some cases, the entrance of the downstream cutter bushing is slightly radiused to minimize jamming. While this practice helps accommodate bushing bores that are not quite aligned, it has a negative effect on cut quality.

- The shear surface of both the upstream and downstream cutter bushings should be sharp and bored to the same size. NOTE: In high speed cutting applications, the downstream bushing is sometimes bored 0.005" larger than the upstream bushing to minimize jamming. Deburr the edge after the boring operation, but be careful to remove only the burr and not the edge.
- Leave a minimum land of 1/8 - 1/4" on the face of the cutter bushing beyond the bore. Angle the rest of the bushing face with a 10-15 degree lead-in.

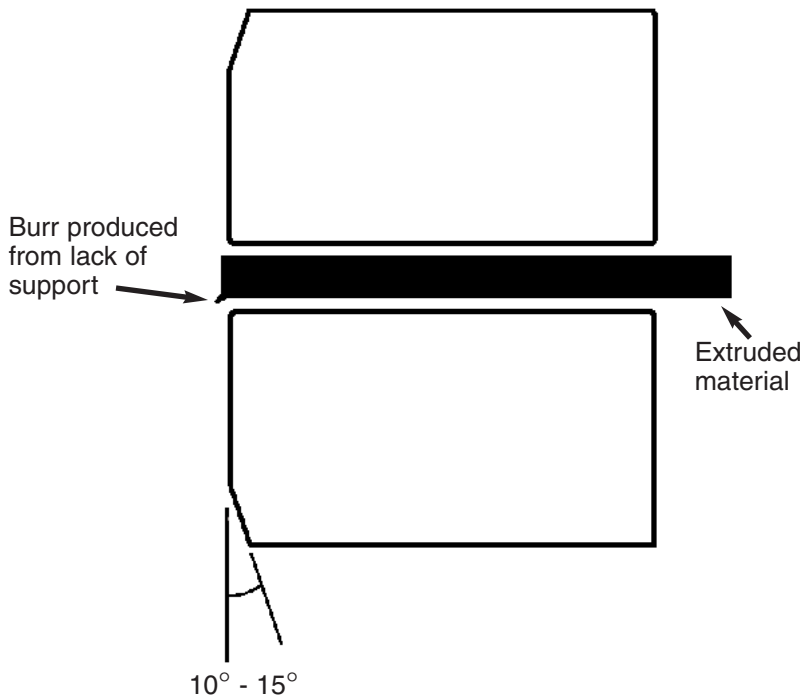

ALL ABOUT CUTTER BUSHINGS

Cutter bushing length



CAUTION: Blade hazard

In order to comply with OSHA regulations, the distance from the sidewall of the cutter to the blade (through the bushing) must be long enough to prevent fingers from reaching the blade.

On flexible extrudates, it is important to minimize the length of the cutter bushings. It is very difficult to push flexible extrudates through since it tends to compress as it is pushed, causing a marginal increase in the tube diameter. For this reason, bushing lubrication may be necessary to minimize drag as the length of the bushings increase. A discharge conveyor may also be helpful in removing longer cut parts. The exit bushing may be funneled to allow the cut part to drop out faster while still maintaining minimal bushing length for safety.

- For flexibles, the upstream cutter bushing should offer total support to the extrudate as close to the nip point of the puller as possible. In this way the part is not able to move from side to side or bow from the weight of the tube, which can, in turn, cause variable drag. You use the strength of the tube to push itself.
- The bore length of the exit bushing should not be shorter than 1 1/2 times the diameter of the tube with the remainder of the bushing length being tapered. On sticky flexible extrudates, the parts will actually stick back together if the new part has to push the cut part out very far.

For rigid extrudates, the length of the cutter bushings can result in a square cut or an angular cut. The cutter bushings support the extrudate keeping it from moving from side to side and bowing from the weight of the profile itself. Many processors make their bushings short to minimize cost of EDM which is determined by depth of cut.

- For rigid extrudates, a general rule is to make the length of the cutting bushings equal to two times the largest outside dimension. NOTE: In the case of full profile cutter bushings where maximum support is offered, the bushing length may be shortened depending on actual clearance.
- Be sure to have a lead-in angle machined into the entrance of the upstream cutter bushing. The transition from the bore to the lead-in angle should not be abrupt as it to can cause variable drag.

Adjusting the cutter bushing gap

If the bushing gap is too big, material is dragged down between the bushings creating a burr, especially with flexibles. This may lead to jamming within the bushings where the upstream side of the cut extrudate actually hits against the downstream bushing surface. This is especially apparent with flexibles with non-concentric walls where a slight bow is present.

- Locate the downstream bushing such that it touches the blade without deflecting it. Lock it in place and rotate the blade to check proper gap.
- Locate the upstream cutter bushing with 0.001-0.002 inch of the blade and lock it in place. Rotate the blade through the set bushings to insure proper gap. NOTE: Because blades are rarely perfectly flat, it is possible that a swishing sound will be heard.
- If hairs are present on only the upstream cut end of a tube or profile, it may be necessary to allow a 0.002-0.005 inch gap on the downstream bushing to allow the blade to slightly move with the extrudate during the cutting cycle and not cause excessive frictional heat which actually melts the extrudate. NOTE: Blade/bushing lubrication can also help to solve this problem.

ALL ABOUT CUTTER BUSHINGS

Blade and bushing lubrication can nearly always improve the quality of cutting.

Description of the cutting process

Unlike sawing, a rotary knife cutter displaces material rather than removing it. When the knife blade first contacts the extrudate, it pushes it against the opposite side of the cutter bushings. If there is too much clearance the extrudate may crack or distort before cutting even begins. Tubing may develop two distinctive marks related to the compression of the tube.

Once the blade penetrates the part, material is displaced to either side of the blade. This displacement will vary in degree and visibility depending on the type of material, temperature, blade thickness, blade style, and blade speed. As the material is displaced, heat is generated and passed to the blade surface.

Flexible materials (flexible PVC, urethanes, and even LDPE) will generally compress during cutting, leaving little or no sign of displacement. The cut will appear uniformly glossy and free of fracture. However, a closer look will show very fine lines on the cut face. With flexible materials, these lines will typically show an arc or "S" pattern which can be attributed to compression of the part as the blade passed through.

Rigid materials such as rigid PVC and styrene will tend to fracture during cutting. The cut surface changes from glossy to dull, and finally becomes whitened and rough. Whitening occurs when cutting changes to fracturing: the cut begins to extend in front of the cutting blade, which acts as a wedge. At this point, you can only hope the fracture is controlled, allowing for a square cut.

Friction and heat during cutting

Because most rotary knife cutters don't travel with the flow of the extrusion line, forward motion is interrupted as the blade passes through the plastic tube or profile. This interruption causes friction, which generates heat in the cutting blade. As the temperature of the blade increases, plastic is melted at the cut site. This melted plastic can adhere to and coat the cutting blade, especially on the upstream side, and be transferred to the next part in the form of hairs or tissue-like film. This will be especially noticeable on the top inside of the tube or profile.

BLADE AND BUSHING LUBRICATION

BLADE AND BUSHING LUBRICATION

If the blade has a rough surface where the extrudate rubs against it, material will accumulate on the blade in a cheese grater fashion. This scratched material will also be passed from the blade to the next cut and be seen as hairs or flakes.

Some of the more flexible materials, such as silicones, soft urethanes and flexible PVCs, also exhibit drag against the blade during the cutting cycle. The part will actually stick to the side of the blade and drag down between the bushings. Typically a small "c" shaped tail of the tube will accumulate in the bottom of the cutting chamber. This tail actually tore off the tube rather than cut due to the excessive drag against the blade

The generation of heat during cutting can also lead to parts that stick to each other. They may appear to be welded together, and an extra operation may be required to separate them. This can be a real problem in materials such as latex, silicone, PP, and flexible PVC.

Benefits of using lubricants

The primary benefit of using a cutting lubricant is reducing friction. If the cutting blade is coated with a film of lubricant, the coefficient of friction between the blade and the plastic tube or profile is reduced, reducing the generation of frictional heat.

Lubricants also minimize the tendency for material to stick to the blade, thus minimizing the potential for material to be wiped on the next cut part. The coefficient of friction is reduced with varying degrees, depending on the type of lubricant, which in turn limits the increase in blade temperature. Over time this can lead to an increase in blade life because the cutting edge will last longer at cooler operating temperatures.

While lubricants can also help minimize problems caused by rough or poorly ground blades and cutter bushings, it is generally better to solve the problem than mask it with lubricants.

Common cutting lubricants

Commonly used general purpose lubricants include:

- Tap water
- Dish washing liquid (Joy, etc)
- Glycol (anti-freeze, coolant)
- Water-soluble silicone cutting oils
- Diesel fuel
- Mold release
- Mineral oil

Medical grade lubricants:

- Distilled water
- Isopropanol (isopropyl alcohol)
- Mixtures of isopropanol and water

Lubrication systems

The most basic blade lubrication system for rotary knife cutters is using a stainless steel tray filled with the lubricant. Because the cutting blade passes through the tray during every cutting cycle, the blade is lubricated before each cut. This approach limits material buildup on blade and bushing surfaces for most applications. Care must be taken to maintain the lubricant level within the tray and clean out accumulated cut residue on a regular basis.

Spray mist systems can be used to lubricate either the blade or the extrudate as it enters the cutter bushings. These systems allow the application of a minimum amount of lubricant with good consistency. If the mist is applied to the product as it enters the cutter bushings, the lubricant will minimize the drag between the bushing bore and the tube or profile, as well as wet the blade and bushing faces. With flexible and/or sticky materials this can improve both cut quality and cut-to-length accuracy.

The last method of blade lubrication (and the oldest) is the blade wipe system. Felt, sponge, or some other absorbent material is mounted so the rotary knife blade will pass through it, with interference, before making a cut. Typically a gravity drip or wick system is used to keep the absorbent material wet with lubricant. These systems not only lubricate the blade, but also wipe off residue before each cut. However, the operator must constantly observe the condition of the pads as they wear quickly and lose their function. Another concern (especially in medical applications) is what happens to wear particles from the pads. This material frequently ends up on the blade itself, and is then transferred to the very product it is meant to protect from contamination.

When considering puller performance, an important concern is the type of puller belt. To select the proper belt material, you must consider the extrudate's tendency to deform under pressure. For example, thin wall profiles and tubing are prone to deformation, so you need lower pressures and longer traction lengths to deliver the required pulling force without deformation and slippage.

Various belt materials are available: natural rubber, neoprene, urethane, and dual material. Available belts are listed under Conair Belts in this Appendix.

CHOOSING BELT MATERIALS

CONAIR BELTS

Part No.	Material	Durometer	Covering Thickness	Color	Wear	Traction	FDA Approved
<i>Poly V380 J 21</i>							
173-051-01	Natural Rubber	35-40	. in (3mm)	white	medium	excellent	Yes
173-051-02	Nitrile	80	. in (3mm)	white	excellent	medium	Yes
<i>Poly V480 J 21</i>							
173-052-01	Natural Rubber	35-40	. in (3mm)	white	medium	excellent	Yes
173-052-02	Nitrile	80	. in (3mm)	white	excellent	medium	Yes

This table shows the settings for each control parameter set at the factory. The parameters are set either to the default setting, or to a setting specific to your requirements (Customer column). If you change any value, record it in this column. Keep these values up-to-date so you can easily restore your puller to normal operation if the memory is corrupted.

PULLER CONTROL SETTINGS

If the control's memory is corrupted by electrical noise or static, you may need to reset the control parameters.

Code	Parameter	Range	Default	Customer
<i>Setpoint Control</i>				
01	Primary Setpoint 1	0000-9999		
02	Primary Setpoint 2	0000-9999		
03	Secondary Setpoint 1	0000-9999		
04	Secondary Setpoint 2	0000-9999		
05	Jog Setpoint	0000-9999		
06	Output Setpoint	0000-9999		
<i>Alarms and Limits</i>				
10	Minimum Limit	0000-9999		
11	Maximum Limit	0000-9999		
12	Low Alarm	0000-9999		
13	High Alarm	0000-9999		
14	Error Alarm 1, ramped	0000-9999		
15	Error Alarm 2, scaled	0000-9999		
<i>Acceleration and Deceleration</i>				
16	Acceleration time	000.0-600.0		
17	Deceleration time	000.0-600.0		
<i>Phase Control</i>				
18	Lag Pulse Limit	0-9999		
19	Lead Pulse Limit	0-9999		
<i>Scaling</i>				
20	Engineering units (primary setpoint)	000.0-9999		
21	Engineering units (secondary setpoint)	000.0-9999		
22	Engineering units (primary display)	000.0-9999		
23	Engineering units (secondary display)	000.0-9999		
<i>Phase Control</i>				
29	Recovery multiplier	0-100		
<i>Scaling</i>				
30	PPR (external reference input)	1-9999		
31	PPR (feedback input)	1-9999	60	
32	PPR (auxiliary input)	1-9999		
33	Max RPM (external reference input: primary mode)	1-9999		
34	Max RPM (feedback: primary mode)	1-9999	1750	
35	Max RPM (auxiliary input: primary mode)	1-9999		

PULLER CONTROL SETTINGS

Code	Parameter	Range	Default	Customer
36	Max RPM (external reference input: secondary mode)	1-9999		
37	Max RPM (feedback: secondary mode)	1-9999		
38	Max RPM (auxiliary input: secondary mode)	1-9999		
<i>Scaling Format Selection and Control</i>				
60	Output format	1-2		
61	Primary scaling mode	0-3	01	
62	Secondary scaling mode	0-3		
63	Primary display mode	1-2	01	
64	Secondary display mode	1-2		
<i>Tuning</i>				
65	Gain	0-9999		
66	Reset (integral)	0-9999		
67	Rate (derivative)	0-9999		
68	Trim authority	0-100		
69	Rate threshold	0-100		
<i>Serial Communications</i>				
70	Device addresses	1-32		
71	Baud rate	1-6		
72	Character format	1-3		
73	Control mask	0-255		
<i>Alarms and Limits</i>				
74	Zero speed logic	0-1		
<i>Scaling Format Selection and Control</i>				
75	Primary mode positive offset	0-9999		
76	Primary mode negative offset	0-9999		
77	Secondary mode positive offset	0-9999		
78	Secondary mode negative offset	0-9999		
<i>Setpoint Control</i>				
79	Setpoint mask	0-2		
<i>Analog Input/Output</i>				
80	Analog output function select	0-99		
81	Analog output range	0-9999		
82	Analog output zero	0-2048		
83	Analog output span	2048-4095		
84	Analog input function select	0-7		
85	Analog input zero	0-2048		
86	Analog input span	2048-4095		

BLADE SPEED CONTROL SETTINGS

This table shows the settings for each control parameter set at the factory. The parameters are set either to the default setting, or to a setting specific to your requirements (Customer column). If you change any value, record it in this column. Keep these values up-to-date so you can easily restore your puller to normal operation if the memory is corrupted.

Code	Parameter	Range	Default	Customer
<i>Setpoint Control</i>				
01	Primary Setpoint 1	0000-9999		
02	Primary Setpoint 2	0000-9999		
03	Secondary Setpoint 1	0000-9999		
04	Secondary Setpoint 2	0000-9999		
05	Jog Setpoint	0000-9999		
06	Output Setpoint	0000-9999		
<i>Alarms and Limits</i>				
10	Minimum Limit	0000-9999		
11	Maximum Limit	0000-9999		
12	Low Alarm	0000-9999		
13	High Alarm	0000-9999		
14	Error Alarm 1, ramped	0000-9999		
15	Error Alarm 2, scaled	0000-9999		
<i>Acceleration and Deceleration</i>				
16	Acceleration time	000.0-600.0		
17	Deceleration time	000.0-600.0		
<i>Phase Control</i>				
18	Lag Pulse Limit	0-9999		
19	Lead Pulse Limit	0-9999		
<i>Scaling</i>				
20	Engineering units (primary setpoint)	000.0-9999		
21	Engineering units (secondary setpoint)	000.0-9999		
22	Engineering units (primary display)	000.0-9999		
23	Engineering units (secondary display)	000.0-9999		
<i>Phase Control</i>				
29	Recovery multiplier	0-100		
<i>Scaling</i>				
30	PPR (external reference input)	1-9999		
31	PPR (feedback input)	1-9999	60	
32	PPR (auxiliary input)	1-9999		
33	Max RPM (external reference input: primary mode)	1-9999		
34	Max RPM (feedback: primary mode)	1-9999	1750	
35	Max RPM (auxiliary input: primary mode)	1-9999		

If the control's memory is corrupted by electrical noise or static, you may need to reset the control parameters.

BLADE SPEED CONTROL SETTINGS

Code	Parameter	Range	Default	Customer
36	Max RPM (external reference input: secondary mode)	1-9999		
37	Max RPM (feedback: secondary mode)	1-9999		
38	Max RPM (auxiliary input: secondary mode)	1-9999		
<i>Scaling Format Selection and Control</i>				
60	Output format	1-2		
61	Primary scaling mode	0-3	01	
62	Secondary scaling mode	0-3		
63	Primary display mode	1-2	01	
64	Secondary display mode	1-2		
<i>Tuning</i>				
65	Gain	0-9999		
66	Reset (integral)	0-9999		
67	Rate (derivative)	0-9999		
68	Trim authority	0-100		
69	Rate threshold	0-100		
<i>Serial Communications</i>				
70	Device addresses	1-32		
71	Baud rate	1-6		
72	Character format	1-3		
73	Control mask	0-255		
<i>Alarms and Limits</i>				
74	Zero speed logic	0-1		
<i>Scaling Format Selection and Control</i>				
75	Primary mode positive offset	0-9999		
76	Primary mode negative offset	0-9999		
77	Secondary mode positive offset	0-9999		
78	Secondary mode negative offset	0-9999		
<i>Setpoint Control</i>				
79	Setpoint mask	0-2		
<i>Analog Input/Output</i>				
80	Analog output function select	0-99		
81	Analog output range	0-9999		
82	Analog output zero	0-2048		
83	Analog output span	2048-4095		
84	Analog input function select	0-7		
85	Analog input zero	0-2048		
86	Analog input span	2048-4095		

ADVANCED PROCEDURE: PID TUNING

PID (Proportional, Integral, Differential) tuning is the process of setting the control algorithm parameters (codes 65-69) to achieve optimum performance. While each puller is tuned before shipment to optimize performance over the entire speed range, customers may wish to tune the puller for their specific operating conditions.

Code	Description	Procedure
65	Gain - small number increase the contribution of the Porportional component. Zero eliminatles the Gain contribution.	<ol style="list-style-type: none"> 1. Set Reset (66) and Rate (67) to zero. 2. Set Trim Authority (68) to 100. 3. Reduce the Gain setting until the system becomes unstable. 4. Increase Gain slightly to re-stabilize the system.
66	Reset - small numbers increase the contribution of the Integral component. Zero eliminates the Reset contribution.	Decrease the value of Reset until overshoot is observed. Overshoot occurs when the feedback goes over the desired setpoint before settling to the desired value.
67	Rate - small numbers increase the contribution of the Derivative component. Zero eliminates the Rate contribution.	<ol style="list-style-type: none"> 1. Decrease the value of Rate until the system becomes unstable. 2. Increase Rate slightly to re-stabilize the system.
68	Trim authority - determines how much of the output is influenced by Gain, Reset and Rate, and how much is determined by feed-forward.	Start with Trim Authority set at 100. If stable operation cannot be achieved, reduce this parameter and repeat the tuning procedure.
69	Rate threshold -sets the amount of differential error required before the Rate term influences the control output.	If unstable operation occurs only at very low feedback frequencies, slightly increase the this parameter.

USING THE DIGITAL BELT GAP SENSOR

The digital belt gap sensor uses a linear scale attached to both belts to measure the relative distance between the belts. The relative distance is shown in thousandths of an inch (.001). The sensor has five buttons:

- On/Off - Turns the device on and off.
- Mode - Press to choose the readout in decimals, fractions, or millimeters.
- + - Press to move up one engineering unit.
- 0 - Press to zero the reading. Because all measurements are relative, the sensor can be set to zero at any time by pressing this button.
- - - press to move down one engineering unit.

Readings displays on the digital display.

For more information, refer to the belt gap sensor manual.

