



MSB SERIES



WARNING - Reliance on this Manual Could Result in Severe Bodily Injury or Death!

This manual is out-of-date and is provided only for its technical information, data and capacities. Portions of this manual detailing procedures or precautions in the operation, inspection, maintenance and repair of the product forming the subject matter of this manual may be inadequate, inaccurate, and/or incomplete and cannot be used, followed, or relied upon. Contact Conair at info@conairgroup.com or 1-800-654-6661 for more current information, warnings, and materials about more recent product manuals containing warnings, information, precautions, and procedures that may be more adequate than those contained in this out-of-date manual.

UGE062/ACHV

METAPLAST... The Downstream Specialists

WARRANTY	II
1.0 RECEIVING AND HANDLING	1
1.1 ACCEPTANCE.....	1
1.2 STORAGE	1
2.0 GENERAL DESCRIPTION	1
2.1 FEATURES.....	1
2.1.1 <i>Standard features</i>	1
2.1.2 <i>Optional features</i>	1
2.2 CLOSED CIRCUIT OPTION	1
2.2.1 <i>Components</i>	2
2.3 TANK MOVEMENT ON FLOOR STAND.....	2
3.0 INSTALLATION / SET UP	2
3.1 LOCATION	2
3.2 LEVELING AND ALIGNMENT	2
3.3 POWER SUPPLY.....	2
4.0 OPERATION / START-UP	3
4.1 OPERATOR ADJUSTMENTS WITH CLOSED COOLING CIRCUIT.....	3
4.1.1 <i>Water Input Supply</i>	3
4.1.2 <i>Overflow Connection</i>	3
4.1.3 <i>Tank Drain Ball Valve</i>	3
4.1.4 <i>Heat Exchanger Connections</i>	3
4.1.5 <i>Drain-Out Line</i>	3
4.2 OPERATOR ADJUSTMENTS WITH OPEN COOLING CIRCUIT.....	3
4.2.1 <i>Water Input Supply</i>	3
4.2.2 <i>Drain-Out Line</i>	4
4.3 OPERATION.....	4
5.0 MAINTENANCE	4
5.1 DAILY (OR AT EACH START-UP).....	5
5.2 QUARTERLY (OR EVERY 1500 HOURS).....	5
5.3 FILTERS (ON CLOSED CIRCUIT EQUIPPED UNITS)	5
5.4 BYPASS	5
APPENDIX A “Drawing”	SECTION 1
APPENDIX B “Electric diagram”	SECTION 2
APPENDIX C “water pumps ”	SECTION 3
APPENDIX D “heat exchanger ”	SECTION 4

WARRANTY

New Apparatus Warranty: Conair/ Metaplast warrants all new equipment to be free of defects in materials and workmanship and to conform to any drawings and specifications for a period of one (1) year from the date of shipment. Equipment that is defective and found not to be in conformity with this warranty will, at the option and expense of Conair/Metaplast, be repaired or replaced.

This warranty does not cover:

- 1) Failures not reported within the warranty period.
- 2) Damage due to misapplication, abuse, improper installations or abnormal temperature, dirt or corrosive matter.
- 3) Failure due to operation, intentional otherwise, above rated capacities.
- 4) Alterations, or tampering, by anyone other than an authorized Conair/ Metaplast representative.
- 5) Damage in shipment.
- 6) Expense incurred by the Buyer in attempt to rework any alleged defects.

1.0 RECEIVING AND HANDLING

1.1 Acceptance

Thoroughly inspect equipment before accepting shipment from the transport company. Damage and shortages should be noted on your freight bill by the receiving agent. If concealed loss or damage is discovered, notify your freight, or receiving agent, at once and request for an inspection.

Conair/Metaplast will assist you in collecting claims for loss or damage in shipment; however, responsibility rests with the transport company. Claims can not be deducted nor should payment be withheld on any Conair/Metaplast invoice, as the carrier guarantees safe delivery.

1.2 Storage

If the equipment is to be stored for any period of time prior to installation, the area should be dry, and not subject to extremes in temperature, or humidity changes. Be aware that after use prior to storage, the machine should be inspected, and lubrication applied where, and as, needed. This is done in order to prevent bearings to be damaged by contaminated grease.

2.0 GENERAL DESCRIPTION

Located as part of the downstream production line, the MSB cooling tank, cools down the extrusion in order to.

2.1 Features

2.1.1 Standard features

- Stainless steel tank construction.
- Lower and upper spray individually controlled in each compartment.
- Quick fill ball valve for fast flooding.
- Quick dump drain with ball valve.
- Hold down rollers.
- Adjustable stand pipe for water level.
- Thermometer.
- Rear mounted main water drain and water supply.
- Foot walk (6 inches wide) along entire table base length.
- Caster-mounted floor stands with floor locking jackscrews.
- Heavy-duty, all steel welded construction.
- All parts painted or plated to resist corrosion.
- Right to left machine operation.

2.1.2 Optional features

- Motorized longitudinal movement.

2.2 Closed circuit option

The closed circuit option saves on water consumption by processing used and than reusing it to cool down the extrusion.

2.2.1 Components

- Reservoir
- Heat exchanger
- Water filtration system with bypass.

2.3 *Tank Movement on Floor Stand*

18" longitudinal movement
6-inch manually adjustable height movement.
3-inch manually adjustable lateral movement.

3.0 **INSTALLATION / SET UP**

3.1 *Location*

Machine is to be located where ambient temperature does not exceed 40° C, and where clean air has free access to ventilating inlets and outlets. Except for specially equipped units with protective enclosures, the location must be clean and dry.

3.2 *Leveling and Alignment*

The MSB is supplied with four floor lock jackscrews (mounted on the base plate) to enable a firm base.

It is recommended that a plumb line be strung from the extruder to the last machine installed to ensure proper alignment of the extrusion machinery with the extruder.

3.3 *Power Supply*

230, 460 or 575 volts; 3 phase; 60 Hz.

Note: All internal wiring has been performed at the Conair/Metaplast factory - it is only necessary to connect a male electrical plug to the provided wire cable and plug it into the mating female receptacle.

Before applying power, check the voltage nameplate to ensure compatibility with the power source.

4.0 OPERATION / START-UP

4.1 *Operator Adjustments with closed cooling circuit**

4.1.1 Water Input Supply*

The water line must be connected to the rear mounted solenoid control valve to supply water to the reservoir. Once the power is applied, the reservoir tank will automatically fill to a preset level.

4.1.2 Overflow Connection

The overflow port is used as a safety measure, in case the reservoir receives a surge of water. It must be connected to the plant drain system.

4.1.3 Tank Drain Ball Valve

The tank drain ball valve is located at the base of the reservoir tank. It must be connected to the plant drain system.

4.1.4 Heat Exchanger Connections

The MVS may be equipped with a heat exchanger to remove any excessive heat build up in the reservoir.

The plant water cooling system must be connected to the heat exchanger ports (at the rear of the machine).

4.1.5 Drain-Out Line

The drain-out line is used to drain the reservoir. Connect the drain-out line from the ball valve (located at the rear of the machine) to the plant drain system.

4.1.6 Adjusting water level

To adjust the water level position the stand pipe slightly below the desired level.

To drain the reservoir tank

- Close off the water supply to the tank.
- Close the valve to the heat exchanger.
- Open the drain out valve.
- Start the process pump.

4.2 *Operator Adjustments with open cooling circuit*

4.2.1 Water Input Supply

Connect water direct to water manifold and to the vacuum pumps liquid service line.

* On models equipped with water recirculation unit only.

4.2.2 Drain-Out Line

The drain-out line must be connected to the plant drain.

4.3 Operation

- 1) Connect the power line (supplied with the tank) to the plant power supply.
- 2) Connect the water line to the WATER IN solenoid valve at the rear of the tank.
- 3) Connect the drain-out line and overflow outlet to the plant drain system.
- 4) Connect the plant cooling water system to the heat exchanger* (located at the rear of the machine).
- 5) Turn on the WATER IN line to the tank.
Note: Water will not start to flow into the reservoir tank until the power disconnect switch is turned on.
- 6) Turn disconnect switch (located on the main electrical panel) to the ON position to apply power to the MVS.

The CIRCULATION STOP push-button will illuminate, and the reservoir tank will begin to fill with water. The tank will stop filling at a preset level.

Note: The water level is controlled with a level control system. When at a low level, the tank will fill with water; at a high level, the tank will stop filling.

- 7) Press the CIRCULATION START push-button to start the water circulation system.
- 8) Start the vacuum pumps. Press START PUMP #1 and close all vacuum-tooling valves on the manifold. Suction should develop (as well as be seen) on the gauge for this pump.
- 9) Press START PUMP #2 and perform the same test.
- 10) Start the extruder, and feed the profile through the tank, haul-off, and cut-off saw.
- 11) Once the profile is steady within the production line, start the calibration process to begin the sizing operation.

5.0 MAINTENANCE

The MVS must be kept in good working order to assure a consistent product. Check frequently to ensure freedom from obstructions and smooth operation. The use of high quality materials and conservative machine design will result in a long, trouble-free operation providing that basic service practices are followed.

Inspection at intervals, dependent upon service conditions, is the best insurance against costly maintenance and breakdown; experience is your best guide. Record inspection results and action required or performed.

- All the bearings are sealed and lubricated for life.
- Grease nipples indicate the grease points.
- Regular lubrication will ensure low maintenance as well as long machine life.

* On models equipped with water recirculation unit only.

5.1 Daily (or at each start-up)

- Check and clean, the overflow screens on the stand pipes.
- Check all the water supply lines and vacuum hoses for any leaks or cracks.
- Ensure that all the guards are in place and that the door to the electrical control cabinet is closed.
- Verify that the table FORWARD and REVERSE movements are smooth and unobstructed.

5.2 Quarterly (or every 1500 hours)

- Disconnect the power from the MSB tank.
- Check and grease all the table movements, including the table movement spindle and bushings.
- Change the oil in the gear reducer for the table movement.
Note: For the proper grade of oil, refer to the information sheet: Flexline, "Worm Gear Speed Reducers, Lubrication and Installation", supplied in this manual.
- Verify that all the motor couplings are in good shape (no wear), and that they rotate freely by hand.
- Vacuum all the dust from the electrical cabinet and all components.
- Tighten all the electrical connections inside the electrical cabinet.
- Check that all the fuses holders.
- Check all the gaskets secure are in the fuse around the electrical cabinets and have them replaced if damaged.
- Check all the wire conduits to the motors for any damage. Change the conduit if there is any damage on the outer surface.

5.3 Filters (on closed circuit equipped units) *

The MSB has filters used to prevent debris from entering the circulation system. To ensure maximum filtration, clean the filter weekly.

5.4 Bypass *

The MSB is equipped with a bypass system in order to avoid interruption of the calibration line when a filter needs to be cleaned or changed during operation.

* On models equipped with water recirculation unit only.

464-300-9010-00 Main box (W/O Vacuum pump, Level Control)

	Metaplast No	Description	Part No	Manufacturer	Qty
7	315-011-2006	Safety covers (serie 62000-63000)	8530	Gould	3
8	315-017-3013	Splitter (4 opening 185 Amp)	63133	Gould	1
9	315-010-2020	Fuse holder 2 Pole (ATM style)	30312	Gould	1
12	315-001-1013	Breaker (1.5 Amp)	MG17413	Merlin Gerin	1
13	315-017-3001	Power supply 120V for lamp	P9PDNVO	G.E	5
14	315-011-1000	Light bulb for pushbutton (120V)	BA9S130	G.E	5
15	315-015-3007	Name plate "STOP"	P9ACP2R201	G.E	2
16	315-014-2033	Contact block N.C	P9B01VN	G.E	2
17	315-015-5028	Push button red illum.	P9CPLRGD	G.E	2
18	315-015-3006	Name plate "START"	P9ACP2R202	G.E	2
19	315-014-2035	Contact block N.O	P9B10VN	G.E	2
20	315-015-5026	Push button green illum.	P9CPLVGD	G.E	2
21	315-011-1005	Pilot light green	P9CLVD	G.E	1
22	315-015-3026	Name plate "BLANK"	P9ACP2N	G.E	1
23	315-167-2074	Solenoid valve	30-VX2260-10N-3D	SMC	1
24	315-051-1006	Hold down spring for base S411	HFN	Carlo Gavazzi	1
25	315-015-9002	Base for level control	S411	Carlo Gavazzi	1
26	315-019-3000	Level control	S195166115	Carlo Gavazzi	1
27	315-019-3004	Level sensor	VNY-3	Carlo Gavazzi	1
30	315-002-3099	Device support (mounting CA7)	KBD	Sprecher+Schuh	2
31	315-006-2003	Connecting module (KTA3 to CA7)	KT3-NW23	Sprecher+Schuh	2
32	315-014-2036	Auxiliary contact block (NO)	KT3-25-PE2-10	Sprecher+Schuh	2
35	315-014-6024	Auxiliary contact block (NC)	CA7-PA-01	Sprecher+Schuh	2
36	315-014-6021	Contactors (three phase)	CA7-12-10-U120	Sprecher+Schuh	1
M	315-006-1076	Enclosure / NEMA-12	5412 ES161208	Eurobex	1

464-300-9010-01 230VAC (2HP Rc-2HP Pr.)

1	315-030-1029	Switch handle for L10 "Yellow/Red"	L10-HS4E	Sprecher+Schuh	1
2	315-030-1030	Rod 256mm for L10 disconnect	L10-R1	Sprecher+Schuh	1
3	315-010-2022	Fuse covers for L10 (30Amp)	L10-FCA2	Sprecher+Schuh	1
4	315-002-7016	Terminals shields for L10 (30 Amp)	L10-LNC1	Sprecher+Schuh	1
5	315-015-6061	Disconnect switch fusible 30A (J type)	L10-NJ030P3	Sprecher+Schuh	1
6	315-010-1009	Fuse 15 Amp AJT style	AJT-15	Gould Shawmut	3
10	315-010-1083	Fuse 1 1/2 Amp ATM style	ATM-1 1/2	Gould Shawmut	2
11	315-017-1255	Transformer 150VA 240v / 120v	DO 0150GE20	Transfab	1
28	315-017-2002	Supply block	KT3-25-A3	Sprecher+Schuh	1
29	315-017-5005	Bus bar (connect 2 KTA3-25)	KT3-25-DB-54-2	Sprecher+Schuh	1
33	315-014-1027	Motor circuit controller (4 - 6.3A)	KTA3-25-6.3A	Sprecher+Schuh	1
34	315-014-1027	Motor circuit controller (4 - 6.3A)	KTA3-25-6.3A	Sprecher+Schuh	1
37	315-014-6021	Contactors (three phase)	CA7-12-10-U120	Sprecher+Schuh	1
38	315-164-2015	JetPump 2 H.P. 230/460V	1ST1G5B4	Gould	1
39	315-164-2015	JetPump 2 H.P. 230/460V	1ST1G5B4	Gould	1

464-300-9010-02 460VAC (2HP Rc-2HP Pr.)

1	315-030-1029	Switch handle for L10 "Yellow/Red"	L10-HS4E	Sprecher+Schuh	1
2	315-030-1030	Rod 256mm for L10 disconnect	L10-R1	Sprecher+Schuh	1
3	315-010-2022	Fuse covers for L10 (30Amp)	L10-FCA2	Sprecher+Schuh	1
4	315-002-7016	Terminals shields for L10 (30 Amp)	L10-LNC1	Sprecher+Schuh	1
5	315-015-6061	Disconnect switch fusible 30A (J type)	L10-NJ030P3	Sprecher+Schuh	1
6	315-010-1087	Fuse 12 Amp AJT style	AJT-12	Gould Shawmut	3
10	315-010-1038	Fuse 1 Amp ATM style	ATM-1	Gould	2
11	315-017-1150	Transformer 150VA 480v / 120v	DO 0150OE20	Transfab	1
28	315-017-2002	Supply block	KT3-25-A3	Sprecher+Schuh	1
29	315-017-5005	Bus bar (connect 2 KTA3-25)	KT3-25-DB-54-2	Sprecher+Schuh	1
33	315-014-1026	Motor circuit controller (2.5 - 4A)	KTA3-25-4A	Sprecher+Schuh	1
34	315-014-1026	Motor circuit controller (2.5 - 4A)	KTA3-25-4A	Sprecher+Schuh	1
37	315-014-6021	Contactors (three phase)	CA7-12-10-U120	Sprecher+Schuh	1
38	315-164-2015	JetPump 2 H.P. 230/460V	1ST1G5B4	Gould	1
39	315-164-2015	JetPump 2 H.P. 230/460V	1ST1G5B4	Gould	1

464-300-9010-03 575VAC (2HP Rc-2HP Pr.)

1	315-030-1029	Switch handle for L10 "Yellow/Red"	L10-HS4E	Sprecher+Schuh	1
2	315-030-1030	Rod 256mm for L10 disconnect	L10-R1	Sprecher+Schuh	1
3	315-010-2022	Fuse covers for L10 (30Amp)	L10-FCA2	Sprecher+Schuh	1
4	315-002-7016	Terminals shields for L10 (30 Amp)	L10-LNC1	Sprecher+Schuh	1
5	315-015-6061	Disconnect switch fusible 30A (J type)	L10-NJ030P3	Sprecher+Schuh	1
6	315-010-1087	Fuse 12 Amp AJT style	AJT-12	Gould Shawmut	3
10	315-010-1082	Fuse 3/4 Amp ATM style	ATM-3/4	Gould Shawmut	2
11	315-017-1048	Transformer 150VA 600v / 120v	DO 0150QE20	Transfab	1
28	315-017-2002	Supply block	KT3-25-A3	Sprecher+Schuh	1
29	315-017-5005	Bus bar (connect 2 KTA3-25)	KT3-25-DB-54-2	Sprecher+Schuh	1
33	315-014-1023	Motor circuit controller (1.6 - 2.5A)	KTA3-25-2.5A	Sprecher+Schuh	1
34	315-014-1023	Motor circuit controller (1.6 - 2.5A)	KTA3-25-2.5A	Sprecher+Schuh	1
37	315-014-6021	Contactors (three phase)	CA7-12-10-U120	Sprecher+Schuh	1
38	315-164-2003	JetPump 2 H.P. 575V	1ST1G6B4	Gould	1
39	315-164-2003	JetPump 2 H.P. 575V	1ST1G6B4	Gould	1

464-300-9010-04 230VAC (2HP Rc-5HP Pr.)

1	315-030-1029	Switch handle for L10 "Yellow/Red"	L10-HS4E	Sprecher+Schuh	1
2	315-030-1030	Rod 256mm for L10 disconnect	L10-R1	Sprecher+Schuh	1
3	315-010-2022	Fuse covers for L10 (30Amp)	L10-FCA2	Sprecher+Schuh	1
4	315-002-7016	Terminals shields for L10 (30 Amp)	L10-LNC1	Sprecher+Schuh	1
5	315-015-6061	Disconnect switch fusible 30A (J type)	L10-NJ030P3	Sprecher+Schuh	1
6	315-010-1016	Fuse 25 Amp AJT style	AJT-25	Gould Shawmut	3
10	315-010-1083	Fuse 1 1/2 Amp ATM style	ATM-1 1/2	Gould Shawmut	2
11	315-017-1255	Transformer 150VA 240v / 120v	DO 0150GE20	Transfab	1
28	315-017-2002	Supply block	KT3-25-A3	Sprecher+Schuh	1
29	315-017-5005	Bus bar (connect 2 KTA3-25)	KT3-25-DB-54-2	Sprecher+Schuh	1
33	315-014-1027	Motor circuit controller (4 - 6.3A)	KTA3-25-6.3A	Sprecher+Schuh	1
34	315-014-1022	Motor circuit controller (10 - 16A)	KTA3-25-18A	Sprecher+Schuh	1
37	315-014-6019	Contactors (three phase)	CA7-16-10-U120	Sprecher+Schuh	1
38	315-164-2015	JetPump 2 H.P. 230/460V	1ST1G5B4	Gould	1
39	315-164-2024	JetPump 5 H.P. 230/460V	3BF25035	Gould	1

464-300-9010-05 460VAC (2HP Rc-5HP Pr.)

1	315-030-1029	Switch handle for L10 "Yellow/Red"	L10-HS4E	Sprecher+Schuh	1
2	315-030-1030	Rod 256mm for L10 disconnect	L10-R1	Sprecher+Schuh	1
3	315-010-2022	Fuse covers for L10 (30Amp)	L10-FCA2	Sprecher+Schuh	1
4	315-002-7016	Terminals shields for L10 (30 Amp)	L10-LNC1	Sprecher+Schuh	1
5	315-015-6061	Disconnect switch fusible 30A (J type)	L10-NJ030P3	Sprecher+Schuh	1
6	315-010-1009	Fuse 15 Amp AJT style	AJT-15	Gould Shawmut	3
10	315-010-1038	Fuse 1 Amp ATM style	ATM-1	Gould	2
11	315-017-1150	Transformer 150VA 480v / 120v	DO 0150OE20	Transfab	1
28	315-017-2002	Supply block	KT3-25-A3	Sprecher+Schuh	1
29	315-017-5005	Bus bar (connect 2 KTA3-25)	KT3-25-DB-54-2	Sprecher+Schuh	1
33	315-014-1026	Motor circuit controller (2.5 - 4A)	KTA3-25-4A	Sprecher+Schuh	1
34	315-014-1027	Motor circuit controller (4 - 6.3A)	KTA3-25-6.3A	Sprecher+Schuh	1
37	315-014-6021	Contactors (three phase)	CA7-12-10-U120	Sprecher+Schuh	1
38	315-164-2015	JetPump 2 H.P. 230/460V	1ST1G5B4	Gould	1
39	315-164-2024	JetPump 5 H.P. 230/460V	3BF25035	Gould	1

464-300-9010-06 575VAC (2HP Rc-5HP Pr.)

1	315-030-1029	Switch handle for L10 "Yellow/Red"	L10-HS4E	Sprecher+Schuh	1
2	315-030-1030	Rod 256mm for L10 disconnect	L10-R1	Sprecher+Schuh	1
3	315-010-2022	Fuse covers for L10 (30Amp)	L10-FCA2	Sprecher+Schuh	1
4	315-002-7016	Terminals shields for L10 (30 Amp)	L10-LNC1	Sprecher+Schuh	1
5	315-015-6061	Disconnect switch fusible 30A (J type)	L10-NJ030P3	Sprecher+Schuh	1
6	315-010-1087	Fuse 12 Amp AJT style	AJT-12	Gould Shawmut	3
10	315-010-1082	Fuse 3/4 Amp ATM style	ATM-3/4	Gould Shawmut	2
11	315-017-1048	Transformer 150VA 600v / 120v	DO 0150QE20	Transfab	1
28	315-017-2002	Supply block	KT3-25-A3	Sprecher+Schuh	1
29	315-017-5005	Bus bar (connect 2 KTA3-25)	KT3-25-DB-54-2	Sprecher+Schuh	1
33	315-014-1023	Motor circuit controller (1.6 - 2.5A)	KTA3-25-2.5A	Sprecher+Schuh	1
34	315-014-1027	Motor circuit controller (4 - 6.3A)	KTA3-25-6.3A	Sprecher+Schuh	1
37	315-014-6021	Contactors (three phase)	CA7-12-10-U120	Sprecher+Schuh	1
38	315-164-2003	JetPump 2 H.P. 575V	1ST1G6B4	Gould	1
39	315-164-2026	JetPump 5 H.P. 575V	3BF25037	Gould	1

464-300-9010-07 230VAC (2HP Rc-7,5HP Pr.)

1	315-030-1029	Switch handle for L10 "Yellow/Red"	L10-HS4E	Sprecher+Schuh	1
2	315-030-1030	Rod 256mm for L10 disconnect	L10-R1	Sprecher+Schuh	1
3	315-010-2025	Fuse covers for L10 (60Amp)	L10-FCJ60	Sprecher+Schuh	1
4	315-002-7023	Terminals shields for L10 (60 Amp)	L10-LNC2	Sprecher+Schuh	1
5	315-002-6065	Disconnect switch fusible 60A (J type)	L10-NJ060P3	Sprecher+Schuh	1
6	315-010-1021	Fuse 35 Amp AJT style	AJT-35	Gould Shawmut	3
10	315-010-1083	Fuse 1 1/2 Amp ATM style	ATM-1 1/2	Gould Shawmut	2
11	315-017-1255	Transformer 150VA 240v / 120v	DO 0150GE20	Transfab	1
28	315-017-2002	Supply block	KT3-25-A3	Sprecher+Schuh	1
29	315-017-5005	Bus bar (connect 2 KTA3-25)	KT3-25-DB-54-2	Sprecher+Schuh	1
33	315-014-1027	Motor circuit controller (4 - 6.3A)	KTA3-25-6.3A	Sprecher+Schuh	1
34	315-014-1025	Motor circuit controller (16 - 25A)	KTA3-25-25A	Sprecher+Schuh	1
37	315-014-6022	Contactors (three phase)	CA7-23-10-U120	Sprecher+Schuh	1
38	315-164-2015	JetPump 2 H.P. 230/460V	1ST1G5B4	Gould	1
39	315-164-2027	JetPump 7,5 H.P. 230/460V	3BF27535	Gould	1

464-300-9010-08 460VAC (2HP Rc-7,5HP Pr.)

1	315-030-1029	Switch handle for L10 "Yellow/Red"	L10-HS4E	Sprecher+Schuh	1
2	315-030-1030	Rod 256mm for L10 disconnect	L10-R1	Sprecher+Schuh	1
3	315-010-2022	Fuse covers for L10 (30Amp)	L10-FCA2	Sprecher+Schuh	1
4	315-002-7016	Terminals shields for L10 (30 Amp)	L10-LNC1	Sprecher+Schuh	1
5	315-015-6061	Disconnect switch fusible 30A (J type)	L10-NJ030P3	Sprecher+Schuh	1
6	315-010-1014	Fuse 20 Amp AJT style	AJT-20	Gould Shawmut	3
10	315-010-1038	Fuse 1 Amp ATM style	ATM-1	Gould	2
11	315-017-1150	Transformer 150VA 480v / 120v	DO 0150OE20	Transfab	1
28	315-017-2002	Supply block	KT3-25-A3	Sprecher+Schuh	1
29	315-017-5005	Bus bar (connect 2 KTA3-25)	KT3-25-DB-54-2	Sprecher+Schuh	1
33	315-014-1026	Motor circuit controller (2.5 - 4A)	KTA3-25-4A	Sprecher+Schuh	1
34	315-014-1021	Motor circuit controller (6.3 - 10A)	KTA3-25-10A	Sprecher+Schuh	1
37	315-014-6021	Contactors (three phase)	CA7-12-10-U120	Sprecher+Schuh	1
38	315-164-2015	JetPump 2 H.P. 230/460V	1ST1G5B4	Gould	1
39	315-164-2027	JetPump 7,5 H.P. 230/460V	3BF27535	Gould	1

464-300-9010-09 575VAC (2HP Rc-7,5HP Pr.)

1	315-030-1029	Switch handle for L10 "Yellow/Red"	L10-HS4E	Sprecher+Schuh	1
2	315-030-1030	Rod 256mm for L10 disconnect	L10-R1	Sprecher+Schuh	1
3	315-010-2022	Fuse covers for L10 (30Amp)	L10-FCA2	Sprecher+Schuh	1
4	315-002-7016	Terminals shields for L10 (30 Amp)	L10-LNC1	Sprecher+Schuh	1
5	315-015-6061	Disconnect switch fusible 30A (J type)	L10-NJ030P3	Sprecher+Schuh	1
6	315-010-1009	Fuse 15 Amp AJT style	AJT-15	Gould Shawmut	3
10	315-010-1082	Fuse 3/4 Amp ATM style	ATM-3/4	Gould Shawmut	2
11	315-017-1048	Transformer 150VA 600v / 120v	DO 0150QE20	Transfab	1
28	315-017-2002	Supply block	KT3-25-A3	Sprecher+Schuh	1
29	315-017-5005	Bus bar (connect 2 KTA3-25)	KT3-25-DB-54-2	Sprecher+Schuh	1
33	315-014-1023	Motor circuit controller (1.6 - 2.5A)	KTA3-25-2.5A	Sprecher+Schuh	1
34	315-014-1021	Motor circuit controller (6.3 - 10A)	KTA3-25-10A	Sprecher+Schuh	1
37	315-014-6021	Contactors (three phase)	CA7-12-10-U120	Sprecher+Schuh	1
38	315-164-2003	JetPump 2 H.P. 575V	1ST1G6B4	Gould	1
39	315-164-2029	JetPump 7,5 H.P. 575V	3BF25037	Gould	1

464-300-9011-00 Main box (1 Vacuum pump, Level Control)

	Metaplast No	Description	Part No	Manufacturer	Qty
7	315-011-2006	Safety covers (serie 62000-63000)	8530	Gould	3
8	315-017-3013	Splitter (4 opening 185 Amp)	63133	Gould	1
9	315-010-2020	Fuse holder 2 Pole (ATM style)	30312	Gould	1
12	315-001-1013	Breaker (1.5 Amp)	MG17413	Merlin Gerin	1
13	315-017-3001	Power supply 120V for lamp	P9PDNVO	G.E	7
14	315-011-1000	Light bulb for pushbutton (120V)	BA9S130	G.E	7
15	315-015-3007	Name plate "STOP"	P9ACP2R201	G.E	3
16	315-014-2033	Contact block N.C	P9B01VN	G.E	3
17	315-015-5028	Push button red illum.	P9CPLRGD	G.E	3
18	315-015-3006	Name plate "START"	P9ACP2R202	G.E	3
19	315-014-2035	Contact block N.O	P9B10VN	G.E	3
20	315-015-5026	Push button green illum.	P9CPLVGD	G.E	3
21	315-168-1015	Pressure switch	H100-95303	U.E.	1
22	315-011-1005	Pilot light green	P9CLVD	G.E	1
23	315-015-3026	Name plate "BLANK"	P9ACP2N	G.E	1
24	315-167-2074	Solenoid valve	30-VX2260-10N-3D	SMC	1
25	315-167-2073	Solenoid valve 3/8"	30-VX2330-03N-3D	SMC	1
26	315-051-1006	Hold down spring for base S411	HFN	Carlo Gavazzi	1
27	315-015-9002	Base for level control	S411	Carlo Gavazzi	1
28	315-019-3000	Level control	S195166115	Carlo Gavazzi	1
29	315-019-3004	Level sensor	VNY-3	Carlo Gavazzi	1
32	315-002-3089	Device support (mounting CA7)	KBD	Sprecher+Schuh	3
33	315-006-2003	Connecting module (KTA3 to CA7)	KT3-NW23	Sprecher+Schuh	3
34	315-014-2036	Auxiliary contact block (NO)	KT3-25-PE2-10	Sprecher+Schuh	3
38	315-014-6024	Auxiliary contact block (NC)	CA7-PA-01	Sprecher+Schuh	3
39	315-014-6021	Contactors (three phase)	CA7-12-10-U120	Sprecher+Schuh	1
M	315-006-1108	Enclosure / NEMA-12	5412 ES201608	Eurobex	1

464-300-9011-01 230VAC (5HP Vc.-2HP Rc-2HP Pr.)

1	315-030-1029	Switch handle for L10 "Yellow/Red"	L10-HS4E	Sprecher+Schuh	1
2	315-030-1030	Rod 256mm for L10 disconnect	L10-R1	Sprecher+Schuh	1
3	315-010-2022	Fuse covers for L10 (30Amp)	L10-FCA2	Sprecher+Schuh	1
4	315-002-7016	Terminals shields for L10 (30 Amp)	L10-LNC1	Sprecher+Schuh	1
5	315-015-6061	Disconnect switch fusible 30A (J type)	L10-NJ030P3	Sprecher+Schuh	1
6	315-010-1021	Fuse 35 Amp AJT style	AJT-35	Gould Shawmut	3
10	315-010-1083	Fuse 1 1/2 Amp ATM style	ATM-1 1/2	Gould Shawmut	2
11	315-017-1255	Transformer 150VA 240v / 120v	DO 0150GE20	Transfab	1
30	315-017-2002	Supply block	KT3-25-A3	Sprecher+Schuh	1
31	315-017-5008	Bus bar (connect 3 KTA3-25)	KT3-25-DB-54-3	Sprecher+Schuh	1
35	315-014-1027	Motor circuit controller (4 - 6.3A)	KTA3-25-6.3A	Sprecher+Schuh	1
36	315-014-1027	Motor circuit controller (4 - 6.3A)	KTA3-25-6.3A	Sprecher+Schuh	1
37	315-014-1022	Motor circuit controller (10 - 16A)	KTA3-25-16A	Sprecher+Schuh	1
40	315-014-6021	Contactors (three phase)	CA7-12-10-U120	Sprecher+Schuh	1
41	315-014-6019	Contactors (three phase)	CA7-16-10-U120	Sprecher+Schuh	1
42	315-164-2015	JetPump 2 H.P. 230/460V	1ST1G5B4	Gould	1
43	315-164-2015	JetPump 2 H.P. 230/460V	1ST1G5B4	Gould	1
44	315-012-0032	Motor AC 5 H.P 230/460V	VM3615T	Baldor	1

464-300-9011-02 460VAC (5HP Vc.-2HP Rc-2HP Pr.)

1	315-030-1029	Switch handle for L10 "Yellow/Red"	L10-HS4E	Sprecher+Schuh	1
2	315-030-1030	Rod 256mm for L10 disconnect	L10-R1	Sprecher+Schuh	1
3	315-010-2022	Fuse covers for L10 (30Amp)	L10-FCA2	Sprecher+Schuh	1
4	315-002-7016	Terminals shields for L10 (30 Amp)	L10-LNC1	Sprecher+Schuh	1
5	315-015-6061	Disconnect switch fusible 30A (J type)	L10-NJ030P3	Sprecher+Schuh	1
6	315-010-1019	Fuse 30 Amp AJT style	AJT-30	Gould Shawmut	3
10	315-010-1038	Fuse 1 Amp ATM style	ATM-1	Gould	2
11	315-017-1150	Transformer 150VA 480v / 120v	DO 0150OE20	Transfab	1
30	315-017-2002	Supply block	KT3-25-A3	Sprecher+Schuh	1
31	315-017-5008	Bus bar (connect 3 KTA3-25)	KT3-25-DB-54-3	Sprecher+Schuh	1
35	315-014-1026	Motor circuit controller (2.5 - 4A)	KTA3-25-4A	Sprecher+Schuh	1
36	315-014-1026	Motor circuit controller (2.5 - 4A)	KTA3-25-4A	Sprecher+Schuh	1
37	315-014-1021	Motor circuit controller (6.3 - 10A)	KTA3-25-10A	Sprecher+Schuh	1
40	315-014-6021	Contactors (three phase)	CA7-12-10-U120	Sprecher+Schuh	1
41	315-014-6021	Contactors (three phase)	CA7-12-10-U120	Sprecher+Schuh	1
42	315-164-2015	JetPump 2 H.P. 230/460V	1ST1G5B4	Gould	1
43	315-164-2015	JetPump 2 H.P. 230/460V	1ST1G5B4	Gould	1
44	315-012-0032	Motor AC 5 H.P 230/460V	VM3615T	Baldor	1

464-300-9011-03 575VAC (5HP Vc.-2HP Rc-2HP Pr.)

1	315-030-1029	Switch handle for L10 "Yellow/Red"	L10-HS4E	Sprecher+Schuh	1
2	315-030-1030	Rod 256mm for L10 disconnect	L10-R1	Sprecher+Schuh	1
3	315-010-2022	Fuse covers for L10 (30Amp)	L10-FCA2	Sprecher+Schuh	1
4	315-002-7016	Terminals shields for L10 (30 Amp)	L10-LNC1	Sprecher+Schuh	1
5	315-015-6061	Disconnect switch fusible 30A (J type)	L10-NJ030P3	Sprecher+Schuh	1
6	315-010-1016	Fuse 25 Amp AJT style	AJT-25	Gould Shawmut	3
10	315-010-1082	Fuse 3/4 Amp ATM style	ATM-3/4	Gould Shawmut	2
11	315-017-1048	Transformer 150VA 600v / 120v	DO 0150QE20	Transfab	1
30	315-017-2002	Supply block	KT3-25-A3	Sprecher+Schuh	1
31	315-017-5008	Bus bar (connect 3 KTA3-25)	KT3-25-DB-54-3	Sprecher+Schuh	1
35	315-014-1023	Motor circuit controller (1.6 - 2.5A)	KTA3-25-2.5A	Sprecher+Schuh	1
36	315-014-1023	Motor circuit controller (1.6 - 2.5A)	KTA3-25-2.5A	Sprecher+Schuh	1
37	315-014-1027	Motor circuit controller (4 - 6.3A)	KTA3-25-6.3A	Sprecher+Schuh	1
40	315-014-6021	Contactors (three phase)	CA7-12-10-U120	Sprecher+Schuh	1
41	315-014-6021	Contactors (three phase)	CA7-12-10-U120	Sprecher+Schuh	1
42	315-164-2003	JetPump 2 H.P. 575V	1ST1G6B4	Gould	1
43	315-164-2003	JetPump 2 H.P. 575V	1ST1G6B4	Gould	1
44	315-012-0053	Motor AC 5 H.P 575V	VM3615T-5	Baldor	1

464-300-9011-04 230VAC (5HP Vc.-2HP Rc-5HP Pr.)

1	315-030-1029	Switch handle for L10 "Yellow/Red"	L10-HS4E	Sprecher+Schuh	1
2	315-030-1030	Rod 256mm for L10 disconnect	L10-R1	Sprecher+Schuh	1
3	315-010-2025	Fuse covers for L10 (60Amp)	L10-FCJ60	Sprecher+Schuh	1
4	315-002-7023	Terminals shields for L10 (60 Amp)	L10-LNC2	Sprecher+Schuh	1
5	315-002-6065	Disconnect switch fusible 60A (J type)	L10-NJ060P3	Sprecher+Schuh	1
6	315-010-1025	Fuse 50 Amp AJT style	AJT-50	Gould Shawmut	3
10	315-010-1083	Fuse 1 1/2 Amp ATM style	ATM-1 1/2	Gould Shawmut	2
11	315-017-1255	Transformer 150VA 240v / 120v	DO 0150GE20	Transfab	1
30	315-017-2002	Supply block	KT3-25-A3	Sprecher+Schuh	1
31	315-017-5008	Bus bar (connect 3 KTA3-25)	KT3-25-DB-54-3	Sprecher+Schuh	1
35	315-014-1027	Motor circuit controller (4 - 6.3A)	KTA3-25-6.3A	Sprecher+Schuh	1
36	315-014-1022	Motor circuit controller (10 - 16A)	KTA3-25-16A	Sprecher+Schuh	1
37	315-014-1022	Motor circuit controller (10 - 16A)	KTA3-25-16A	Sprecher+Schuh	1
40	315-014-6019	Contactors (three phase)	CA7-16-10-U120	Sprecher+Schuh	1
41	315-014-6019	Contactors (three phase)	CA7-16-10-U120	Sprecher+Schuh	1
42	315-164-2015	JetPump 2 H.P. 230/460V	1ST1G5B4	Gould	1
43	315-164-2024	JetPump 5 H.P. 230/460V	3BF25035	Gould	1
44	315-012-0032	Motor AC 5 H.P 230/460V	VM3615T	Baldor	1

464-300-9011-05 460VAC (5HP Vc.-2HP Rc-5HP Pr.)

1	315-030-1029	Switch handle for L10 "Yellow/Red"	L10-HS4E	Sprecher+Schuh	1
2	315-030-1030	Rod 256mm for L10 disconnect	L10-R1	Sprecher+Schuh	1
3	315-010-2022	Fuse covers for L10 (30Amp)	L10-FCA2	Sprecher+Schuh	1
4	315-002-7016	Terminals shields for L10 (30 Amp)	L10-LNC1	Sprecher+Schuh	1
5	315-015-6061	Disconnect switch fusible 30A (J type)	L10-NJ030P3	Sprecher+Schuh	1
6	315-010-1014	Fuse 20 Amp AJT style	AJT-20	Gould Shawmut	3
10	315-010-1038	Fuse 1 Amp ATM style	ATM-1	Gould	2
11	315-017-1150	Transformer 150VA 480v / 120v	DO 0150OE20	Transfab	1
30	315-017-2002	Supply block	KT3-25-A3	Sprecher+Schuh	1
31	315-017-5008	Bus bar (connect 3 KTA3-25)	KT3-25-DB-54-3	Sprecher+Schuh	1
35	315-014-1026	Motor circuit controller (2.5 - 4A)	KTA3-25-4A	Sprecher+Schuh	1
36	315-014-1027	Motor circuit controller (4 - 6.3A)	KTA3-25-6.3A	Sprecher+Schuh	1
37	315-014-1021	Motor circuit controller (6.3 - 10A)	KTA3-25-10A	Sprecher+Schuh	1
40	315-014-6021	Contactors (three phase)	CA7-12-10-U120	Sprecher+Schuh	1
41	315-014-6021	Contactors (three phase)	CA7-12-10-U120	Sprecher+Schuh	1
42	315-164-2015	JetPump 2 H.P. 230/460V	1ST1G5B4	Gould	1
43	315-164-2024	JetPump 5 H.P. 230/460V	3BF25035	Gould	1
44	315-012-0032	Motor AC 5 H.P 230/460V	VM3615T	Baldor	1

464-300-9011-06 575VAC (5HP Vc.-2HP Rc-5HP Pr.)

1	315-030-1029	Switch handle for L10 "Yellow/Red"	L10-HS4E	Sprecher+Schuh	1
2	315-030-1030	Rod 256mm for L10 disconnect	L10-R1	Sprecher+Schuh	1
3	315-010-2022	Fuse covers for L10 (30Amp)	L10-FCA2	Sprecher+Schuh	1
4	315-002-7016	Terminals shields for L10 (30 Amp)	L10-LNC1	Sprecher+Schuh	1
5	315-015-6061	Disconnect switch fusible 30A (J type)	L10-NJ030P3	Sprecher+Schuh	1
6	315-010-1014	Fuse 20 Amp AJT style	AJT-20	Gould Shawmut	3
10	315-010-1082	Fuse 3/4 Amp ATM style	ATM-3/4	Gould Shawmut	2
11	315-017-1048	Transformer 150VA 600v / 120v	DO 0150QE20	Transfab	1
30	315-017-2002	Supply block	KT3-25-A3	Sprecher+Schuh	1
31	315-017-5008	Bus bar (connect 3 KTA3-25)	KT3-25-DB-54-3	Sprecher+Schuh	1
35	315-014-1023	Motor circuit controller (1.6 - 2.5A)	KTA3-25-2.5A	Sprecher+Schuh	1
36	315-014-1027	Motor circuit controller (4 - 6.3A)	KTA3-25-6.3A	Sprecher+Schuh	1
37	315-014-1027	Motor circuit controller (4 - 6.3A)	KTA3-25-6.3A	Sprecher+Schuh	1
40	315-014-6021	Contactors (three phase)	CA7-12-10-U120	Sprecher+Schuh	1
41	315-014-6021	Contactors (three phase)	CA7-12-10-U120	Sprecher+Schuh	1
42	315-164-2003	JetPump 2 H.P. 575V	1ST1G6B4	Gould	1
43	315-164-2026	JetPump 5 H.P. 575V	3BF25037	Gould	1
44	315-012-0053	Motor AC 5 H.P 575V	VM3615T-5	Baldor	1

464-300-9011-07 230VAC (5HP Vc.-2HP Rc-7,5HP Pr.)

1	315-030-1029	Switch handle for L10 "Yellow/Red"	L10-HS4E	Sprecher+Schuh	1
2	315-030-1030	Rod 256mm for L10 disconnect	L10-R1	Sprecher+Schuh	1
3	315-010-2025	Fuse covers for L10 (60Amp)	L10-FCJ60	Sprecher+Schuh	1
4	315-002-7023	Terminals shields for L10 (60 Amp)	L10-LNC2	Sprecher+Schuh	1
5	315-002-6065	Disconnect switch fusible 60A (J type)	L10-NJ060P3	Sprecher+Schuh	1
6	315-010-1025	Fuse 50 Amp AJT style	AJT-50	Gould Shawmut	3
10	315-010-1083	Fuse 1 1/2 Amp ATM style	ATM-1 1/2	Gould Shawmut	2
11	315-017-1255	Transformer 150VA 240v / 120v	DO 0150GE20	Transfab	1
30	315-017-2002	Supply block	KT3-25-A3	Sprecher+Schuh	1
31	315-017-5008	Bus bar (connect 3 KTA3-25)	KT3-25-DB-54-3	Sprecher+Schuh	1
35	315-014-1027	Motor circuit controller (4 - 6.3A)	KTA3-25-6.3A	Sprecher+Schuh	1
36	315-014-1025	Motor circuit controller (16 - 25A)	KTA3-25-25A	Sprecher+Schuh	1
37	315-014-1022	Motor circuit controller (10 - 16A)	KTA3-25-16A	Sprecher+Schuh	1
40	315-014-6022	Contactors (three phase)	CA7-23-10-U120	Sprecher+Schuh	1
41	315-014-6019	Contactors (three phase)	CA7-16-10-U120	Sprecher+Schuh	1
42	315-164-2015	JetPump 2 H.P. 230/460V	1ST1G5B4	Gould	1
43	315-164-2027	JetPump 7,5 H.P. 230/460V	3BF27535	Gould	1
44	315-012-0032	Motor AC 5 H.P 230/460V	VM3615T	Baldor	1

464-300-9011-08 460VAC (5HP Vc.-2HP Rc-7,5HP Pr.)

1	315-030-1029	Switch handle for L10 "Yellow/Red"	L10-HS4E	Sprecher+Schuh	1
2	315-030-1030	Rod 256mm for L10 disconnect	L10-R1	Sprecher+Schuh	1
3	315-010-2022	Fuse covers for L10 (30Amp)	L10-FCA2	Sprecher+Schuh	1
4	315-002-7016	Terminals shields for L10 (30 Amp)	L10-LNC1	Sprecher+Schuh	1
5	315-015-6061	Disconnect switch fusible 30A (J type)	L10-NJ030P3	Sprecher+Schuh	1
6	315-010-1016	Fuse 25 Amp AJT style	AJT-25	Gould Shawmut	3
10	315-010-1038	Fuse 1 Amp ATM style	ATM-1	Gould	2
11	315-017-1150	Transformer 150VA 480v / 120v	DO 0150OE20	Transfab	1
30	315-017-2002	Supply block	KT3-25-A3	Sprecher+Schuh	1
31	315-017-5008	Bus bar (connect 3 KTA3-25)	KT3-25-DB-54-3	Sprecher+Schuh	1
35	315-014-1026	Motor circuit controller (2.5 - 4A)	KTA3-25-4A	Sprecher+Schuh	1
36	315-014-1021	Motor circuit controller (6.3 - 10A)	KTA3-25-10A	Sprecher+Schuh	1
37	315-014-1021	Motor circuit controller (6.3 - 10A)	KTA3-25-10A	Sprecher+Schuh	1
40	315-014-6021	Contactors (three phase)	CA7-12-10-U120	Sprecher+Schuh	1
41	315-014-6021	Contactors (three phase)	CA7-12-10-U120	Sprecher+Schuh	1
42	315-164-2015	JetPump 2 H.P. 230/460V	1ST1G5B4	Gould	1
43	315-164-2027	JetPump 7,5 H.P. 230/460V	3BF27535	Gould	1
44	315-012-0032	Motor AC 5 H.P 230/460V	VM3615T	Baldor	1

464-300-9011-09 575VAC (5HP Vc.-2HP Rc-7,5HP Pr.)

1	315-030-1029	Switch handle for L10 "Yellow/Red"	L10-HS4E	Sprecher+Schuh	1
2	315-030-1030	Rod 256mm for L10 disconnect	L10-R1	Sprecher+Schuh	1
3	315-010-2022	Fuse covers for L10 (30Amp)	L10-FCA2	Sprecher+Schuh	1
4	315-002-7016	Terminals shields for L10 (30 Amp)	L10-LNC1	Sprecher+Schuh	1
5	315-015-6061	Disconnect switch fusible 30A (J type)	L10-NJ030P3	Sprecher+Schuh	1
6	315-010-1014	Fuse 20 Amp AJT style	AJT-20	Gould Shawmut	3
10	315-010-1082	Fuse 3/4 Amp ATM style	ATM-3/4	Gould Shawmut	2
11	315-017-1048	Transformer 150VA 600v / 120v	DO 0150QE20	Transfab	1
30	315-017-2002	Supply block	KT3-25-A3	Sprecher+Schuh	1
31	315-017-5008	Bus bar (connect 3 KTA3-25)	KT3-25-DB-54-3	Sprecher+Schuh	1
35	315-014-1023	Motor circuit controller (1.6 - 2.5A)	KTA3-25-2.5A	Sprecher+Schuh	1
36	315-014-1021	Motor circuit controller (6.3 - 10A)	KTA3-25-10A	Sprecher+Schuh	1
37	315-014-1027	Motor circuit controller (4 - 6.3A)	KTA3-25-6.3A	Sprecher+Schuh	1
40	315-014-6021	Contactors (three phase)	CA7-12-10-U120	Sprecher+Schuh	1
41	315-014-6021	Contactors (three phase)	CA7-12-10-U120	Sprecher+Schuh	1
42	315-164-2003	JetPump 2 H.P. 575V	1ST1G8B4	Gould	1
43	315-164-2029	JetPump 7,5 H.P. 575V	3BF25037	Gould	1
44	315-012-0053	Motor AC 5 H.P 575V	VM3615T-5	Baldor	1

464-300-9011-10 230VAC (7,5HP Vc.-2HP Rc-2HP Pr.)

1	315-030-1029	Switch handle for L10 "Yellow/Red"	L10-HS4E	Sprecher+Schuh	1
2	315-030-1030	Rod 256mm for L10 disconnect	L10-R1	Sprecher+Schuh	1
3	315-010-2025	Fuse covers for L10 (60Amp)	L10-FCJ60	Sprecher+Schuh	1
4	315-002-7023	Terminals shields for L10 (60 Amp)	L10-LNC2	Sprecher+Schuh	1
5	315-002-6065	Disconnect switch fusible 60A (J type)	L10-NJ060P3	Sprecher+Schuh	1
6	315-010-1025	Fuse 50 Amp AJT style	AJT-50	Gould Shawmut	3
10	315-010-1083	Fuse 1 1/2 Amp ATM style	ATM-1 1/2	Gould Shawmut	2
11	315-017-1255	Transformer 150VA 240v / 120v	DO 0150GE20	Transfab	1
30	315-017-2002	Supply block	KT3-25-A3	Sprecher+Schuh	1
31	315-017-5008	Bus bar (connect 3 KTA3-25)	KT3-25-DB-54-3	Sprecher+Schuh	1
35	315-014-1027	Motor circuit controller (4 - 6.3A)	KTA3-25-6.3A	Sprecher+Schuh	1
36	315-014-1027	Motor circuit controller (4 - 6.3A)	KTA3-25-6.3A	Sprecher+Schuh	1
37	315-014-1025	Motor circuit controller (16 - 25A)	KTA3-25-25A	Sprecher+Schuh	1
40	315-014-6021	Contactors (three phase)	CA7-12-10-U120	Sprecher+Schuh	1
41	315-014-6022	Contactors (three phase)	CA7-23-10-U120	Sprecher+Schuh	1
42	315-164-2015	JetPump 2 H.P. 230/460V	1ST1G5B4	Gould	1
43	315-164-2015	JetPump 2 H.P. 230/460V	1ST1G5B4	Gould	1
44	315-012-0036	Motor AC 7,5 H.P 230/460V	VM3710T	Baldor	1

464-300-9011-11 460VAC (7,5HP Vc.-2HP Rc-2HP Pr.)

1	315-030-1029	Switch handle for L10 "Yellow/Red"	L10-HS4E	Sprecher+Schuh	1
2	315-030-1030	Rod 256mm for L10 disconnect	L10-R1	Sprecher+Schuh	1
3	315-010-2022	Fuse covers for L10 (30Amp)	L10-FCA2	Sprecher+Schuh	1
4	315-002-7016	Terminals shields for L10 (30 Amp)	L10-LNC1	Sprecher+Schuh	1
5	315-015-6061	Disconnect switch fusible 30A (J type)	L10-NJ030P3	Sprecher+Schuh	1
6	315-010-1014	Fuse 20 Amp AJT style	AJT-20	Gould Shawmut	3
10	315-010-1038	Fuse 1 Amp ATM style	ATM-1	Gould	2
11	315-017-1150	Transformer 150VA 480v / 120v	DO 0150QE20	Transfab	1
30	315-017-2002	Supply block	KT3-25-A3	Sprecher+Schuh	1
31	315-017-5008	Bus bar (connect 3 KTA3-25)	KT3-25-DB-54-3	Sprecher+Schuh	1
35	315-014-1026	Motor circuit controller (2.5 - 4A)	KTA3-25-4A	Sprecher+Schuh	1
36	315-014-1026	Motor circuit controller (2.5 - 4A)	KTA3-25-4A	Sprecher+Schuh	1
37	315-014-1021	Motor circuit controller (6.3 - 10A)	KTA3-25-10A	Sprecher+Schuh	1
40	315-014-6021	Contactors (three phase)	CA7-12-10-U120	Sprecher+Schuh	1
41	315-014-6021	Contactors (three phase)	CA7-12-10-U120	Sprecher+Schuh	1
42	315-164-2015	JetPump 2 H.P. 230/460V	1ST1G5B4	Gould	1
43	315-164-2015	JetPump 2 H.P. 230/460V	1ST1G5B4	Gould	1
44	315-012-0036	Motor AC 7,5 H.P 230/460V	VM3710T	Baldor	1

464-300-9011-12 575VAC (7,5HP Vc.-2HP Rc-2HP Pr.)

1	315-030-1029	Switch handle for L10 "Yellow/Red"	L10-HS4E	Sprecher+Schuh	1
2	315-030-1030	Rod 256mm for L10 disconnect	L10-R1	Sprecher+Schuh	1
3	315-010-2022	Fuse covers for L10 (30Amp)	L10-FCA2	Sprecher+Schuh	1
4	315-002-7016	Terminals shields for L10 (30 Amp)	L10-LNC1	Sprecher+Schuh	1
5	315-015-6061	Disconnect switch fusible 30A (J type)	L10-NJ030P3	Sprecher+Schuh	1
6	315-010-1016	Fuse 25 Amp AJT style	AJT-25	Gould Shawmut	3
10	315-010-1082	Fuse 3/4 Amp ATM style	ATM-3/4	Gould Shawmut	2
11	315-017-1048	Transformer 150VA 600v / 120v	DO 0150QE20	Transfab	1
30	315-017-2002	Supply block	KT3-25-A3	Sprecher+Schuh	1
31	315-017-5008	Bus bar (connect 3 KTA3-25)	KT3-25-DB-54-3	Sprecher+Schuh	1
35	315-014-1023	Motor circuit controller (1.6 - 2.5A)	KTA3-25-2.5A	Sprecher+Schuh	1
36	315-014-1023	Motor circuit controller (1.6 - 2.5A)	KTA3-25-2.5A	Sprecher+Schuh	1
37	315-014-1027	Motor circuit controller (4 - 6.3A)	KTA3-25-6.3A	Sprecher+Schuh	1
40	315-014-6021	Contactors (three phase)	CA7-12-10-U120	Sprecher+Schuh	1
41	315-014-6021	Contactors (three phase)	CA7-12-10-U120	Sprecher+Schuh	1
42	315-164-2003	JetPump 2 H.P. 575V	1ST1G6B4	Gould	1
43	315-164-2003	JetPump 2 H.P. 575V	1ST1G6B4	Gould	1
44	315-012-0033	Motor AC 7,5 H.P 575V	M3710T-5	Baldor	1
45	315-087-2001	C face kit for M3710T-5	37-1304	Baldor	1

464-300-9011-13 230VAC (7,5HP Vc.-2HP Rc-5HP Pr.)

1	315-030-1029	Switch handle for L10 "Yellow/Red"	L10-HS4E	Sprecher+Schuh	1
2	315-030-1030	Rod 256mm for L10 disconnect	L10-R1	Sprecher+Schuh	1
3	315-010-2025	Fuse covers for L10 (60Amp)	L10-FCJ60	Sprecher+Schuh	1
4	315-002-7023	Terminals shields for L10 (60 Amp)	L10-LNC2	Sprecher+Schuh	1
5	315-002-6065	Disconnect switch fusible 60A (J type)	L10-NJ060P3	Sprecher+Schuh	1
6	315-010-1025	Fuse 50 Amp AJT style	AJT-50	Gould Shawmut	3
10	315-010-1083	Fuse 1 1/2 Amp ATM style	ATM-1 1/2	Gould Shawmut	2
11	315-017-1255	Transformer 150VA 240v / 120v	DO 0150GE20	Transfab	1
30	315-017-2002	Supply block	KT3-25-A3	Sprecher+Schuh	1
31	315-017-5008	Bus bar (connect 3 KTA3-25)	KT3-25-DB-54-3	Sprecher+Schuh	1
35	315-014-1027	Motor circuit controller (4 - 6.3A)	KTA3-25-6.3A	Sprecher+Schuh	1
36	315-014-1022	Motor circuit controller (10 - 16A)	KTA3-25-16A	Sprecher+Schuh	1
37	315-014-1025	Motor circuit controller (16 - 25A)	KTA3-25-25A	Sprecher+Schuh	1
40	315-014-6019	Contactors (three phase)	CA7-16-10-U120	Sprecher+Schuh	1
41	315-014-6022	Contactors (three phase)	CA7-23-10-U120	Sprecher+Schuh	1
42	315-164-2015	JetPump 2 H.P. 230/460V	1ST1G5B4	Gould	1
43	315-164-2024	JetPump 5 H.P. 230/460V	3BF25035	Gould	1
44	315-012-0036	Motor AC 7,5 H.P 230/460V	VM3710T	Baldor	1

464-300-9011-14 460VAC (7,5HP Vc.-2HP Rc-5HP Pr.)

1	315-030-1029	Switch handle for L10 "Yellow/Red"	L10-HS4E	Sprecher+Schuh	1
2	315-030-1030	Rod 256mm for L10 disconnect	L10-R1	Sprecher+Schuh	1
3	315-010-2022	Fuse covers for L10 (30Amp)	L10-FCA2	Sprecher+Schuh	1
4	315-002-7016	Terminals shields for L10 (30 Amp)	L10-LNC1	Sprecher+Schuh	1
5	315-015-6061	Disconnect switch fusible 30A (J type)	L10-NJ030P3	Sprecher+Schuh	1
6	315-010-1016	Fuse 25 Amp AJT style	AJT-25	Gould Shawmut	3
10	315-010-1038	Fuse 1 Amp ATM style	ATM-1	Gould	2
11	315-017-1150	Transformer 150VA 480v / 120v	DO 0150OE20	Transfab	1
30	315-017-2002	Supply block	KT3-25-A3	Sprecher+Schuh	1
31	315-017-5008	Bus bar (connect 3 KTA3-25)	KT3-25-DB-54-3	Sprecher+Schuh	1
35	315-014-1026	Motor circuit controller (2.5 - 4A)	KTA3-25-4A	Sprecher+Schuh	1
36	315-014-1027	Motor circuit controller (4 - 6.3A)	KTA3-25-6.3A	Sprecher+Schuh	1
37	315-014-1021	Motor circuit controller (6.3 - 10A)	KTA3-25-10A	Sprecher+Schuh	1
40	315-014-6021	Contactors (three phase)	CA7-12-10-U120	Sprecher+Schuh	1
41	315-014-6021	Contactors (three phase)	CA7-12-10-U120	Sprecher+Schuh	1
42	315-164-2015	JetPump 2 H.P. 230/460V	1ST1G5B4	Gould	1
43	315-164-2024	JetPump 5 H.P. 230/460V	3BF25035	Gould	1
44	315-012-0036	Motor AC 7,5 H.P 230/460V	VM3710T	Baldor	1

464-300-9011-15 575VAC (7,5HP Vc.-2HP Rc-5HP Pr.)

1	315-030-1029	Switch handle for L10 "Yellow/Red"	L10-HS4E	Sprecher+Schuh	1
2	315-030-1030	Rod 256mm for L10 disconnect	L10-R1	Sprecher+Schuh	1
3	315-010-2022	Fuse covers for L10 (30Amp)	L10-FCA2	Sprecher+Schuh	1
4	315-002-7016	Terminals shields for L10 (30 Amp)	L10-LNC1	Sprecher+Schuh	1
5	315-015-6061	Disconnect switch fusible 30A (J type)	L10-NJ030P3	Sprecher+Schuh	1
6	315-010-1014	Fuse 20 Amp AJT style	AJT-20	Gould Shawmut	3
10	315-010-1082	Fuse 3/4 Amp ATM style	ATM-3/4	Gould Shawmut	2
11	315-017-1048	Transformer 150VA 600v / 120v	DO 0150QE20	Transfab	1
30	315-017-2002	Supply block	KT3-25-A3	Sprecher+Schuh	1
31	315-017-5008	Bus bar (connect 3 KTA3-25)	KT3-25-DB-54-3	Sprecher+Schuh	1
35	315-014-1023	Motor circuit controller (1.6 - 2.5A)	KTA3-25-2.5A	Sprecher+Schuh	1
36	315-014-1027	Motor circuit controller (4 - 6.3A)	KTA3-25-6.3A	Sprecher+Schuh	1
37	315-014-1021	Motor circuit controller (6.3 - 10A)	KTA3-25-10A	Sprecher+Schuh	1
40	315-014-6021	Contactors (three phase)	CA7-12-10-U120	Sprecher+Schuh	1
41	315-014-6021	Contactors (three phase)	CA7-12-10-U120	Sprecher+Schuh	1
42	315-164-2003	JetPump 2 H.P. 575V	1ST1G6B4	Gould	1
43	315-164-2026	JetPump 5 H.P. 575V	3BF25037	Gould	1
44	315-012-0033	Motor AC 7,5 H.P 575V	M3710T-5	Baldor	1
45	315-087-2001	C face kit for M3710T-5	37-1304	Baldor	1

464-300-9011-16 230VAC (7,5HP Vc.-2HP Rc-7,5HP Pr.)

1	315-030-1029	Switch handle for L10 "Yellow/Red"	L10-HS4E	Sprecher+Schuh	1
2	315-030-1030	Rod 256mm for L10 disconnect	L10-R1	Sprecher+Schuh	1
3	315-010-2025	Fuse covers for L10 (60Amp)	L10-FCJ60	Sprecher+Schuh	1
4	315-002-7023	Terminals shields for L10 (60 Amp)	L10-LNC2	Sprecher+Schuh	1
5	315-002-6065	Disconnect switch fusible 60A (J type)	L10-NJ060P3	Sprecher+Schuh	1
6	315-010-1026	Fuse 60 Amp AJT style	AJT-60	Gould Shawmut	3
10	315-010-1083	Fuse 1 1/2 Amp ATM style	ATM-1 1/2	Gould Shawmut	2
11	315-017-1255	Transformer 150VA 240v / 120v	DO 0150GE20	Transfab	1
30	315-017-2002	Supply block	KT3-25-A3	Sprecher+Schuh	1
31	315-017-5008	Bus bar (connect 3 KTA3-25)	KT3-25-DB-54-3	Sprecher+Schuh	1
35	315-014-1027	Motor circuit controller (4 - 6.3A)	KTA3-25-6.3A	Sprecher+Schuh	1
36	315-014-1025	Motor circuit controller (16 - 25A)	KTA3-25-25A	Sprecher+Schuh	1
37	315-014-1025	Motor circuit controller (16 - 25A)	KTA3-25-25A	Sprecher+Schuh	1
40	315-014-6022	Contactors (three phase)	CA7-23-10-U120	Sprecher+Schuh	1
41	315-014-6022	Contactors (three phase)	CA7-23-10-U120	Sprecher+Schuh	1
42	315-164-2015	JetPump 2 H.P. 230/460V	1ST1G5B4	Gould	1
43	315-164-2027	JetPump 7,5 H.P. 230/460V	3BF27535	Gould	1
44	315-012-0036	Motor AC 7,5 H.P 230/460V	VM3710T	Baldor	1

464-300-9011-17 460VAC (7,5HP Vc.-2HP Rc-7,5HP Pr.)

1	315-030-1029	Switch handle for L10 "Yellow/Red"	L10-HS4E	Sprecher+Schuh	1
2	315-030-1030	Rod 256mm for L10 disconnect	L10-R1	Sprecher+Schuh	1
3	315-010-2022	Fuse covers for L10 (30Amp)	L10-FCA2	Sprecher+Schuh	1
4	315-002-7016	Terminals shields for L10 (30 Amp)	L10-LNC1	Sprecher+Schuh	1
5	315-015-6061	Disconnect switch fusible 30A (J type)	L10-NJ030P3	Sprecher+Schuh	1
6	315-010-1019	Fuse 30 Amp AJT style	AJT-30	Gould Shawmut	3
10	315-010-1038	Fuse 1 Amp ATM style	ATM-1	Gould	2
11	315-017-1150	Transformer 150VA 480v / 120v	DO 0150OE20	Transfab	1
30	315-017-2002	Supply block	KT3-25-A3	Sprecher+Schuh	1
31	315-017-5008	Bus bar (connect 3 KTA3-25)	KT3-25-DB-54-3	Sprecher+Schuh	1
35	315-014-1028	Motor circuit controller (2.5 - 4A)	KTA3-25-4A	Sprecher+Schuh	1
36	315-014-1021	Motor circuit controller (6.3 - 10A)	KTA3-25-10A	Sprecher+Schuh	1
37	315-014-1022	Motor circuit controller (10 - 16A)	KTA3-25-16A	Sprecher+Schuh	1
40	315-014-6021	Contactors (three phase)	CA7-12-10-U120	Sprecher+Schuh	1
41	315-014-6021	Contactors (three phase)	CA7-12-10-U120	Sprecher+Schuh	1
42	315-164-2015	JetPump 2 H.P. 230/460V	1ST1G5B4	Gould	1
43	315-164-2027	JetPump 7,5 H.P. 230/460V	3BF27535	Gould	1
44	315-012-0036	Motor AC 7,5 H.P 230/460V	VM3710T	Baldor	1

464-300-9011-18 575VAC (7,5HP Vc.-2HP Rc-7,5HP Pr.)

1	315-030-1029	Switch handle for L10 "Yellow/Red"	L10-HS4E	Sprecher+Schuh	1
2	315-030-1030	Rod 256mm for L10 disconnect	L10-R1	Sprecher+Schuh	1
3	315-010-2022	Fuse covers for L10 (30Amp)	L10-FCA2	Sprecher+Schuh	1
4	315-002-7016	Terminals shields for L10 (30 Amp)	L10-LNC1	Sprecher+Schuh	1
5	315-015-6061	Disconnect switch fusible 30A (J type)	L10-NJ030P3	Sprecher+Schuh	1
6	315-010-1016	Fuse 25 Amp AJT style	AJT-25	Gould Shawmut	3
10	315-010-1082	Fuse 3/4 Amp ATM style	ATM-3/4	Gould Shawmut	2
11	315-017-1048	Transformer 150VA 600v / 120v	DO 0150QE20	Transfab	1
30	315-017-2002	Supply block	KT3-25-A3	Sprecher+Schuh	1
31	315-017-5008	Bus bar (connect 3 KTA3-25)	KT3-25-DB-54-3	Sprecher+Schuh	1
35	315-014-1023	Motor circuit controller (1.6 - 2.5A)	KTA3-25-2.5A	Sprecher+Schuh	1
36	315-014-1021	Motor circuit controller (6.3 - 10A)	KTA3-25-10A	Sprecher+Schuh	1
37	315-014-1021	Motor circuit controller (6.3 - 10A)	KTA3-25-10A	Sprecher+Schuh	1
40	315-014-6021	Contactors (three phase)	CA7-12-10-U120	Sprecher+Schuh	1
41	315-014-6021	Contactors (three phase)	CA7-12-10-U120	Sprecher+Schuh	1
42	315-164-2003	JetPump 2 H.P. 575V	1ST1G6B4	Gould	1
43	315-164-2029	JetPump 7,5 H.P. 575V	3BF25037	Gould	1
44	315-012-0033	Motor AC 7,5 H.P 575V	M3710T-5	Baldor	1
45	315-087-2001	C face kit for M3710T-5	37-1304	Baldor	1

APPENDIX C
WATER PUMPS

Installation, Operation and Maintenance Instructions

Model 3656/3756

A9700199

DESCRIPTION & SPECIFICATIONS:

The Models 3656 (close-coupled) and 3756 (frame-mounted) are single-stage end-suction pumps for general service, liquid transfer, booster applications, etc. They are available in three different materials of construction: all-iron, bronze-fitted and all-bronze ("S" Group only). Application will depend on the material of construction.

The pumps have fully enclosed impellers, key driven and held in position by an axial bolt and washer. Casings are full volute in design with replaceable wear ring. Depending on the size, they have either threaded or flanged inlet and discharge connections. Shafts are protected by stainless steel sleeves and shaft sealing is with mechanical seal.

Close-coupled units have NEMA frame motors, C-face mounting, JM shaft extension. Frame mounted units can be coupled to motors through a spacer coupling, or belt driven.

1. Important:

- 1.1. Inspect unit for damage. Report damage to carrier immediately.
- 1.2. Electrical supply must be a separate branch circuit with fuses or circuit breakers, wire size, etc., per National and Local electrical codes. Install an all-leg disconnect switch near pump.

CAUTION

Always disconnect electrical power when handling pump or control.

- 1.3. Motor must be wired for proper voltage (check nameplate). Wire size must limit maximum voltage drop to 10% of nameplate voltage at motor terminals, or motor life and pump performance will be lowered.
- 1.4. Always use horsepower-rated contactors and starters.
- 1.5. Motor Protection

1.5.1. Single-phase: Thermal protection for single-phase unit is sometimes built in (check nameplate). If no built-in protection is provided, use a contactor with a proper overload. Fusing is permissible.

1.5.2. Three-Phase: Provide three-leg protection with properly sized magnetic starter and thermal overloads.

1.6. Maximum Liquid Temperatures:

- 212°F (100°C) with standard seal.
- 250°F (120°C) with optional high temperature seal.

- 1.7. Allowable operating pressure: 175 PSI.
- 1.8. Maximum number of starts per hour: 20, evenly distributed.
- 1.9. Regular inspection and maintenance will increase service life. Base schedule on operating time. Refer To Section 8.

2. Installation:

2.1. General

- 2.1.1. Locate pump as near liquid source as possible (below level of liquid for automatic operation).

CAUTION

Do not install with motor below pump. Any leakage or condensation will effect the motor.

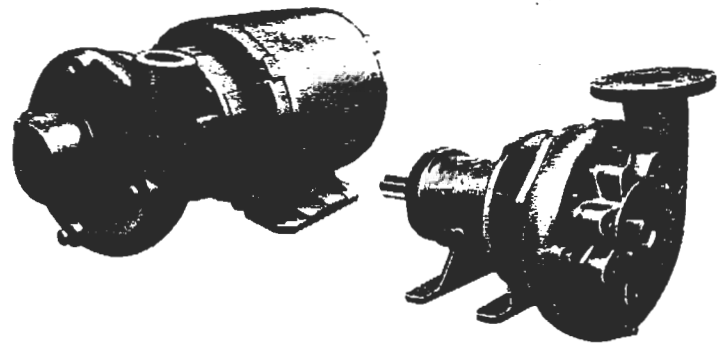

- 2.1.2. Protect from freezing or flooding.
- 2.1.3. Allow adequate space for servicing and ventilation.
- 2.1.4. All piping must be supported independently of the pump, and must "line-up" naturally.

CAUTION

Never draw piping into place by forcing the pump suction and discharge connection.

2.1.5. Avoid unnecessary fittings. Select sizes to keep friction losses to a minimum.

2.1.6. After the piping is complete rotate the unit by hand to check for any binding.

2.2. Close-coupled units:

- 2.2.1. Units may be installed horizontally, inclined or vertically.
- 2.2.2. Foundation must be flat and substantial to eliminate strain when tightening bolts. Use rubber mounts to minimize noise and vibration.
- 2.2.3. Tighten motor hold-down bolts before connecting piping to pump.

2.3. Frame-mounted units:

- 2.3.1. Bedplate must be grouted to a foundation with solid footing. Refer to Fig. 1.
- 2.3.2. Place unit in position on wedges located at four points (two below approximate center of driver and two below approximate center of pump). Adjust wedges to level unit. Level or plumb suction and discharge flanges.
- 2.3.3. Make sure bedplate is not distorted and final coupling alignment can be made within the limits of movement of motor and by shimming, if necessary.

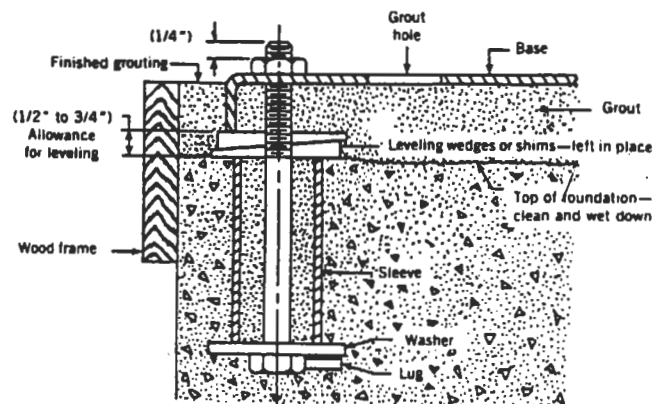

Figure 1

8.2. Frame Mounted Units:

8.2.1. Bearing frame should be regreased every 2,000 hours or 3 month interval, whichever occurs first. Use a #2 sodium or lithium based grease. Fill until grease comes out of relief fittings, or lip seals, then wipe off excess.

8.2.2 Follow motor and coupling manufacturers' lubrication instructions.

8.2.3. Alignment must be rechecked after any maintenance work involving any disturbance of the unit.

9. Disassembly:

Complete disassembly of the unit will be described. Proceed only as far as required to perform the maintenance work needed.

9.1. Turn off power.

9.2. Drain system. Flush if necessary.

9.3. Close-Coupled Units: Remove motor hold-down bolts.

Frame-Mounted Units Remove coupling, spacer, coupling guard and frame hold-down bolts.

9.4. Disassembly of Liquid End:

9.4.1. Remove casing bolts (370).

9.4.2. Remove back pull-out assembly from casing (100).

9.4.3. Unscrew impeller bolt (198) with a socket wrench.

CAUTION

Do not insert screwdriver between impeller vanes to prevent rotation.

It may be necessary to use a strap wrench around the impeller if impacting the socket wrench will not loosen the impeller blot. Hold shaft on frame mounted units.

9.4.4. Remove impeller washer (199).

9.4.5. Use two pry bars, 180 degrees apart, to remove the impeller (101) from shaft.

9.4.6. Remove impeller key (178) and seal spring.

9.4.7. Remove mechanical seal (383) rotating member by using two pry bars, 180 degrees apart. Gently break the bond between the shaft sleeve (126) and the rubber part of the mechanical seal by wedging.

9.4.8. Remove mechanical seal stationary seat by unbolting the adapter (108) from the motor or bearing frame and pushing the seat and rubber cup from the motor side. Adapters for close coupled and frame mounted units are the same.

On all-bronze units a separate seal housing (not illustrated) is used. Unbolt the seal housing from the adapter and remove the stationary seat as explained previously.

9.4.9. Shaft sleeve is bonded and sealed to the shaft with locking compound (Loctite 271, or equal). The bond must be broken before removal can be attempted. Break bond by heating the sleeve with a torch to about 250°F to 300°F. Pull off sleeve.

9.4.10. Casing wear rig (103) and/or seal housing wear ring (203) is removed by drilling a hole about the size of the ring thickness axially to relieve tension. Chisel off the ring toward center.

9.5. Disassembly of Bearing Frame:

9.5.1. Remove bearing cover (134).

9.5.2. Remove shaft assembly from frame (228).

9.5.3. Remove lip seals (333A) from bearing frame and bearing cover.

9.5.4. Straighten tang in lockwasher (382). Remove locknut (136) and lockwasher.

9.5.5. Use bearing puller or arbor press to remove ball bearings (112 & 168).

10. Reassembly:

10.1. All parts should be cleaned before

10.2. Refer to parts list to identify required pump index number when ordering parts

10.3. Reassembly is the reverse of disassembly

10.4. Observe the following when reassembling

10.4.1. Replace lip seals if worn or damaged

10.4.2. Replace ball bearings if loose

10.4.3. Check shaft for runout at tip. If runout is greater than permissible is .002" T.I.R.

10.5. Observe the following when reassembling

10.5.1. Shaft sleeve is locked and sleeve locking compound. Shaft and sleeve must be free. Apply Loctite #271 (Goulds product) to shaft where sleeve fits. Slide shaft on and forth a couple of times to even

CAUTION

Sleeve must seat against shaft shoulder. Follow instructions. Wipe off uncured excess

10.5.2. All mechanical seal components must be replaced whenever seal has been removed, is

It is permissible to use a light lubricant on mechanical seal seat and on the shaft to prevent contaminate the mechanical seal seal

10.5.3. If wear ring is being replaced, use metal-to-metal fit when pressing in

10.5.4. Use a new impeller bolt.

10.5.5. Inspect seal housing O-ring (

10.6. Check reassembled unit for binding

11. Trouble Shooting Chart:

MOTOR NOT RUNNING:

(See Cases 1 thru 6)

LITTLE OR NO LIQUID DELIVERED:

(See Cases 7 thru 17)

POWER CONSUMPTION TOO HIGH:

(See Cases 4, 17, 18, 19, 22)

EXCESSIVE NOISE AND VIBRATION:

(See Cases 4, 6, 9, 13, 15, 16, 18, 20, 22)

PROBABLE CAUSE:

1. Tripped thermal protector

2. Open circuit breaker

3. Blown fuse

4. Rotating parts binding

5. Motor wired improperly

6. Defective motor

7. Not primed

8. Discharge plugged or valve closed

9. Incorrect rotation

10. Foot valve too small or suction not

11. Low voltage

12. Phase loss

13. Air or gases in liquid

14. System head too high

15. NPSHA too low:

Suction lift too high or friction losses excessive. Check vacuum gauge

16. Impeller worn or plugged

17. Incorrect impeller diameter

18. Head too low causing excessive flow

19. Viscosity or specific gravity too high

20. Worn bearings

21. Pump or piping loose

22. Pump and motor misaligned

Installation, Operation and Maintenance Instructions Model 3656/3756

A9700199

DESCRIPTION & SPECIFICATIONS:

The Models 3656 (close-coupled) and 3756 (frame-mounted) are single-stage end-suction pumps for general service, liquid transfer, booster applications, etc. They are available in three different materials of construction: all-iron, bronze-fitted and all-bronze ("S" Group only). Application will depend on the material of construction.

The pumps have fully enclosed impellers, key driven and held in position by an axial bolt and washer. Casings are full volute in design with replaceable wear ring. Depending on the size, they have either threaded or flanged inlet and discharge connections. Shafts are protected by stainless steel sleeves and shaft sealing is with mechanical seal.

Close-coupled units have NEMA frame motors, C-face mounting, JM shaft extension. Frame mounted units can be coupled to motors through a spacer coupling, or belt driven.

1. Important:

- 1.1. Inspect unit for damage. Report damage to carrier immediately.
- 1.2. Electrical supply must be a separate branch circuit with fuses or circuit breakers, wire size, etc., per National and Local electrical codes. Install an all-leg disconnect switch near pump.

CAUTION

Always disconnect electrical power when handling pump or control.

- 1.3. Motor must be wired for proper voltage (check nameplate). Wire size must limit maximum voltage drop to 10% of nameplate voltage at motor terminals, or motor life and pump performance will be lowered.

- 1.4. Always use horsepower-rated contactors and starters.

1.5. Motor Protection

1.5.1. Single-phase: Thermal protection for single-phase unit is sometimes built in (check nameplate). If no built-in protection is provided, use a contactor with a proper overload. Fusing is permissible.

1.5.2. Three-Phase: Provide three-leg protection with properly sized magnetic starter and thermal overloads.

1.6. Maximum Liquid Temperatures:

- 212°F (100°C) with standard seal.
- 250°F (120°C) with optional high temperature seal.

- 1.7. Allowable operating pressure: 175 PSI.

- 1.8. Maximum number of starts per hour: 20, evenly distributed.

- 1.9. Regular inspection and maintenance will increase service life. Base schedule on operating time. Refer To Section 8.

2. Installation:

2.1. General

- 2.1.1. Locate pump as near liquid source as possible (below level of liquid for automatic operation).

CAUTION

Do not install with motor below pump. Any leakage or condensation will effect the motor.

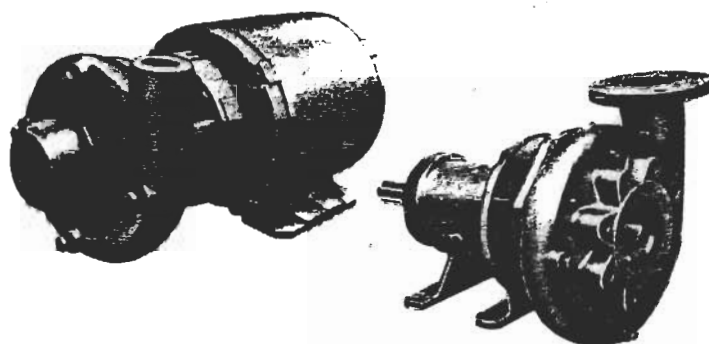

- 2.1.2. Protect from freezing or flooding.
- 2.1.3. Allow adequate space for servicing and ventilation.
- 2.1.4. All piping must be supported independently of the pump, and must "line-up" naturally.

CAUTION

Never draw piping into place by forcing the pump suction and discharge connection.

- 2.1.5. Avoid unnecessary fittings. Select sizes to keep friction losses to a minimum.
- 2.1.6. After the piping is complete rotate the unit by hand to check for any binding.

2.2. Close-coupled units:

- 2.2.1. Units may be installed horizontally, inclined or vertically.
- 2.2.2. Foundation must be flat and substantial to eliminate strain when tightening bolts. Use rubber mounts to minimize noise and vibration.
- 2.2.3. Tighten motor hold-down bolts before connecting piping to pump.

2.3. Frame-mounted units:

- 2.3.1. Bedplate must be grouted to a foundation with solid footing. Refer to Fig. 1.
- 2.3.2. Place unit in position on wedges located at four points (two below approximate center of driver and two below approximate center of pump). Adjust wedges to level unit. Level or plumb suction and discharge flanges.
- 2.3.3. Make sure bedplate is not distorted and final coupling alignment can be made within the limits of movement of motor and by shimming, if necessary.

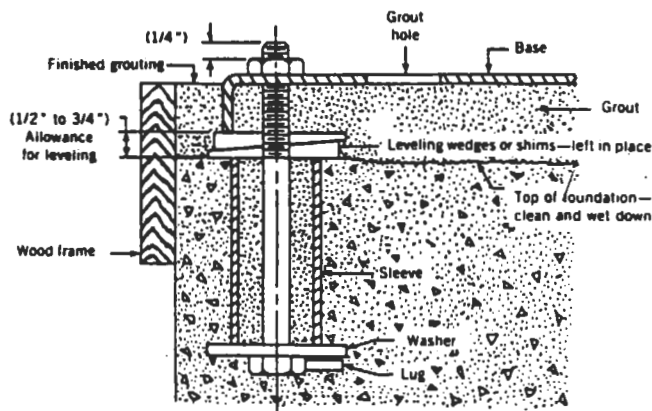

Figure 1

2.3.4. Tighten foundation bolts finger tight and build dam around foundation. Pour grout under bedplate making sure the areas under pump and motor feet are filled solid. Allow grout to harden 48 hours before fully tightening foundation bolts.

2.3.5. Tighten pump and motor hold-down bolts before connecting to piping to pump.

3. Suction Piping:

3.1. Low static lift and short, direct, suction piping is desired. For suction lift over 10 feet and liquid temperature over 120 F, consult pump performance curve for Net Positive Suction Head Required.

3.2. Suction pipe size must be at least equal to suction connection of pump.

3.3. If larger pipe is required, an eccentric pipe reducer (with straight side up) must be installed at the pump.

3.4. Installation with pump below source of supply:

3.4.1. Install isolation valve in piping for inspection and maintenance.

CAUTION

Do not use suction isolation valve to throttle pump.

3.5. Installation with pump above source of supply:

3.5.1. To avoid air pockets, no part of piping should be higher than pump suction connection. Slope piping upward from liquid source.

3.5.2. All joints must be airtight.

3.5.3. Foot valve to be used only if necessary for priming, or to hold prime on intermittent service.

3.5.4. Suction strainer open area must be at least triple the pipe area.

3.6. Size of inlet from liquid source, and minimum submergence over inlet, must be sufficient to prevent air entering pump through vortexing. See Figs. 2-5.

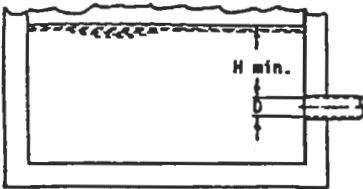

Figure 2

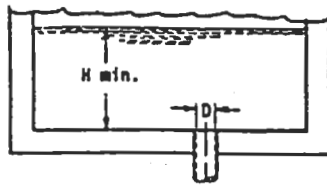

Figure 3

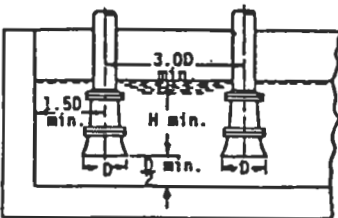

Figure 4

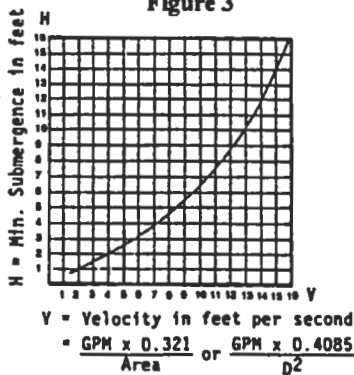

Figure 5

4. Discharge piping:

4.1. Arrangement must include a check valve located between a gate valve and the pump. The gate valve is for regulation of capacity, or for inspection of the pump or check valve.

4.2. If an increaser is required, place between check valve and pump.

5. Motor-To-Pump Shaft Alignment:

5.1. Closed Coupled Units:

5.1.1. No field alignment necessary.

5.2. Frame-Mounted Units:

5.2.1. Even though the pump-motor unit may have a factory alignment, this could be disturbed in transit and must be checked prior to running. See Fig. 6.

5.2.2. Tighten all hold-down bolts before checking the alignment.

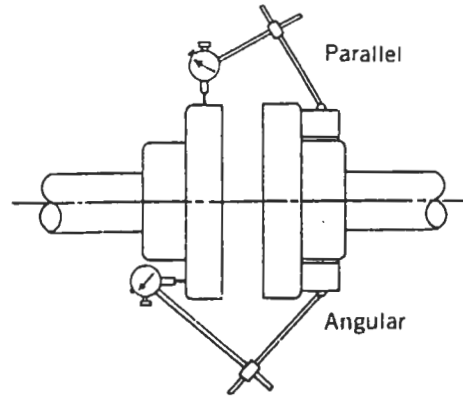

Figure 6

5.2.3. If re-alignment is necessary, always move the motor. Shim as required.

5.2.4. Parallel misalignment-shafts with axes parallel but not concentric. Place dial indicator on one hub and rotate this hub 360 degrees while taking readings on the outside diameter of the other hub. Parallel alignment occurs when Total Indicator Residing is .005", or less.

5.2.5. Angular misalignment-shafts with axes concentric but not parallel. Place dial indicator on one hub and rotate this hub 360 degrees while taking readings on the face of the other hub. Angular alignment is achieved when Total Indicator Reading is .005", or less.

5.2.6. Final alignment is achieved when parallel and angular requirements are satisfied with motor hold-down bolts tight.

CAUTION

Always recheck both alignments after making any adjustment.

6. Rotation:

6.1. Correct rotation is right-hand (Clockwise when viewed from the driver end). Switch power on and off, very briefly. Observe shaft rotation. To change rotation:

6.1.1. Single-Phase: Refer to wiring diagram on motor.

6.1.2. Three-Phase: Interchange any two power supply leads.

7. Operation:

7.1. Before starting, pump must be primed (free of air and suction pipe full of liquid) and discharge valve partially open.

CAUTION

Pumped liquid provides lubrication. If pump is run dry, rotating parts will seize and mechanical seal will be damaged. Do not operate at or near zero flow. Energy imparted to the liquid is converted into heat. Liquid may flash to vapor. Rotating parts require liquid to prevent scoring or seizing.

7.2. Make complete check after unit is run under operating conditions and temperature has stabilized. Check for expansion of piping. On frame-mounted units coupling alignment may have changed due to the temperature differential between pump and motor. Recheck alignment.

8. Maintenance:

8.1. Close-Coupled Units: Bearings are located in and are part of the motor. For lubrication procedure, refer to motor manufacturer's instructions.

7.2. Après le fonctionnement de l'appareil dans des conditions de service normales et la stabilisation de la température, vérifier tout le système. Vérifier également si la tuyauterie s'est dilatée. Dans le cas des pompes montées sur socle, la différence de température entre le moteur et la pompe peut altérer le centrage de l'accouplement. Vérifier le centrage de nouveau.

8. Entretien

8.1. Dans le cas des pompes montées sur moteur, les roulements sont situés à l'intérieur du moteur et sont lubrifiés à vie. Aucun graissage n'est requis.

8.2. Pompes montées sur socle:

8.2.1. Les roulements de palier devraient être graissés toutes les 2000 heures ou tous les trois mois, soit la période prenant fin la première. Employer une graisse au lithium ou au sodium n° 2. Remplir le roulement jusqu'à ce que la graisse sorte par les garnitures ou par la lèvre des joints, puis essuyer le surplus.

8.2.2. Suivre les directives de lubrification du fabricant du moteur et de l'accouplement.

8.2.3. Vérifier le centrage de nouveau après tout travail d'entretien nécessitant le déplacement ou le desserrage des boulons de fixation de l'appareil.

9. Démontage

Le démontage complet de la pompe est décrit ci-dessous. Ne démonter que ce qui est approprié à l'entretien nécessaire.

9.1. Couper le courant.

9.2. Vidanger le système. Le rincer au besoin.

9.3. Dans le cas des pompes montées sur moteur, enlever les boulons de fixation de ce dernier. Quant aux pompes montées sur socle, enlever le grillage ou l'écran protecteur, l'entretoise, l'accouplement et les boulons de fixation du socle.

9.4. Pompe:

9.4.1. Enlever les vis de fixation (370) du corps de pompe.

9.4.2. Écarter l'ensemble pompe du corps de pompe (100).

9.4.3. Enlever l'écrou de blocage (304) de l'impulseur.

ATTENTION

Ne pas insérer de tournevis entre les aubes de l'impulseur pour empêcher de tourner: enlever le couvercle d'extrémité du moteur et utiliser la fente ou les méplats de blocage de l'arbre; on prévient ainsi l'endommagement de l'impulseur.

9.4.4. Dévisser l'impulseur (101) dans le sens antihoraire (vu du devant de la pompe). Se protéger les mains avec un linge ou des gants.

ATTENTION

Toute tentative de dévissage dans le sens horaire peut endommager les filets de l'impulseur ou de l'arbre, ou des deux.

9.4.5. Retirer le logement de joint (184) avec soin au moyen de deux leviers placés dans un angle de 180° entre le logement et l'adaptateur de moteur (108). L'élément tournant du joint mécanique (383) devrait sortir de l'arbre avec le logement.

9.4.6. Pousser l'élément immobile du joint mécanique hors du logement.

9.5. Palier:

9.5.1. Enlever le couvercle de palier (109).

9.5.2. Sortir l'arbre (122) du palier (228).

9.5.3. Si les joints à lèvre (138 et 139) sont usés et doivent être remplacés, les retirer du palier et du couvercle de palier.

9.5.4. À l'aide d'un arrache-roulement ou d'une presse à mandriner, extraire les roulements (112 et 168).

10. Remontage

10.1. Chaque pièce devrait être nettoyée avant le remontage.

10.2. Voir la liste des pièces pour déterminer celles qui sont requises. Préciser le numéro de pièce ou de catalogue de la pompe lorsque l'on commande des pièces.

10.3. Le remontage se fait dans l'ordre inverse du démontage.

10.4. Observer les directives suivantes pendant le remontage du palier:

10.4.1. Remplacer les joints à lèvre s'ils sont usés ou endommagés.

10.4.2. Remplacer les roulements à billes s'ils ont du jeu, s'ils ne tournent pas rond ou s'ils sont bruyants.

10.4.3. Vérifier si l'arbre comporte des faux-ronds: le faux-rond maximal admissible est de 0,051 mm (0,002 po).

10.5. Observer les directives suivantes pendant le remontage de la pompe:

10.5.1. Tous les composants du joint mécanique doivent être en bon état pour empêcher les fuites. Le remplacement du joint en entier est une pratique courante appropriée chaque fois que le joint est enlevé. On peut utiliser un lubrifiant léger comme la glycérine pour faciliter l'assemblage. Ne pas contaminer la surface du joint mécanique avec le lubrifiant.

10.5.2. Inspecter le joint torique (513) du corps de pompe et le remplacer s'il est endommagé. On peut employer du pétrolatum (vaseline) pour faciliter sa pose.

10.5.3. Inspecter le joint torique (349) de l'aube (enveloppe) directrice et le remplacer s'il est endommagé.

ATTENTION

Ne pas lubrifier le joint torique (349) de l'aube directrice. S'assurer que le joint n'est pas pincé par l'impulseur au cours du remontage.

10.6. Une fois la pompe remontée, vérifier s'il y a grippage. Apporter les corrections nécessaires.

10.7. Serrer les vis de fixation du corps de pompe en étoile pour prévenir le coincement du joint torique.

11. Diagnostic des anomalies

Moteur ne fonctionne pas
(V. causes 1 à 6)

Débit de liquide faible ou nul:
(V. causes 7 à 17)

Consommation d'électricité excessive:
(V. causes 4, 17, 18, 19 et 22)

Vibration et bruit excessifs:
(V. causes 4, 6, 9, 13, 15, 16, 18, 20, 21 et 22)

CAUSES PROBABLES:

1. Protecteur thermique déclenché.
2. Disjoncteur ouvert.
3. Fusible sauté.
4. Pièces tournantes grippées.
5. Moteur mal connecté.
6. Moteur défectueux.
7. Pompe non amorcée.
8. Tuyau de refoulement obstrué ou robinet fermé.
9. Mauvais sens de rotation.
10. Clapet de pied trop petit, entrée de tuyau d'aspiration non submergée, crépine de tuyau d'aspiration obstruée.
11. Basse tension électrique.
12. Perte de phase (moteurs triphasés seulement).
13. Présence d'air ou de gaz dans le liquide.
14. Hauteur du système trop grande.
15. Charge nette absolue à l'aspiration trop faible – hauteur ou perte d'aspiration excessives – vérifier avec un vacuomètre.
16. Impulseur usé ou obstrué.
17. Diamètre d'impulseur inapproprié.
18. Hauteur trop faible – vitesse d'écoulement excessive.
19. Viscosité ou densité trop élevée.
20. Roulements usés.
21. Pompe ou tuyauterie mal assujetties.
22. Pompe et moteur désalignés.

Composants et matériaux de fabrication

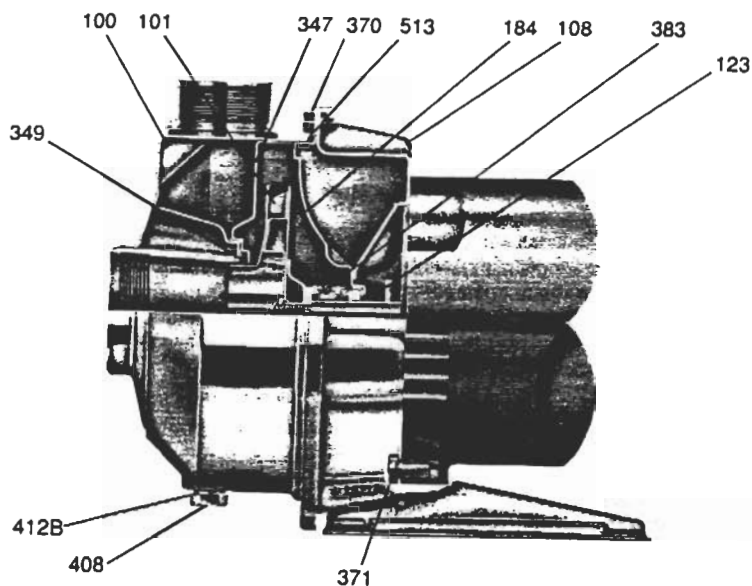

NPE

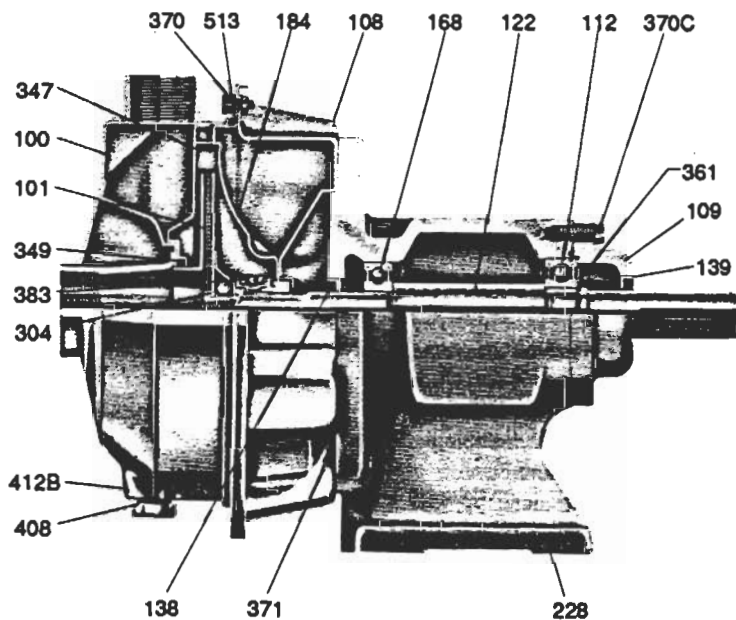

NPE-F

Composants de la pompe

N° d'article	Description	Matériau
100	Corps de pompe	Inox AISI 304
101	Impulseur	
184	Logement de joint	
304	Écrou de blocage - impulseur	
347	Aube (enveloppe) directrice	
349	Joint torique - aube directrice	Buna-N
370	Vis à tête creuse - corps de pompe	Inox AISI 304
383	Joint mécanique	V. tableau**
408	Bouchons de vidange et de mise à l'air libre - corps de pompe	Inox AISI 304
412B	Joint torique - bouchons de vidange et de mise à l'air libre	Buna-N
513	Joint torique - corps de pompe	Buna-N
Organes d'entraînement		
108	Adaptateur	Inox AISI 304
109	Couvercle de palier	Fonte
112	Roulement à billes extérieur	Acier
122	Arbre	Inox AISI 304
138	Joint à lèvres intérieur	Buna, acier
139	Joint à lèvres extérieur	Buna, acier
168	Roulement à billes intérieur	Acier
228	Palier	Fonte
361	Bague de retenue	Acier
370C	Vis à tête hexagonale - couvercle de palier	Acier plaqué
371	Vis à tête hexagonale - adaptateur	Acier plaqué

**Choix de joints mécaniques - article n° 383

N° de pièce	Service	Joint tournant	Joint immobile	Élastomères	Métal	Crane, type
10K46	Standard	Carbone	Céramique	Buna	Inox 18-8	21
10K18	Hautes températures (option)		Fonte Ni-Résist	Éthylène-propylène		
10K24	Produits chimiques (option)		Céramique	Viton		
10K55	Hautes températures (option)		Tungstène			
10K29	Très dur (option)	Carbone, silicium	Buna			

GARANTIE LIMITÉE DE GOULDS

La présente garantie s'applique à chaque pompe de système d'alimentation en eau fabriquée par Goulds.

Toute pièce se révélant défectueuse durant la période de garantie sera remplacée sans frais pour le détaillant durant ladite période, qui durera douze (12) mois à compter de la date d'installation ou dix-huit (18) mois à partir de la date de fabrication, soit la période qui expirera la première.

Le détaillant qui, aux termes de cette garantie, désire effectuer une demande de règlement doit s'adresser au distributeur Goulds agréé chez lequel la pompe a été achetée et fournir tous les détails à l'appui de sa demande. Le distributeur est autorisé à régler toute demande par le biais du service à la clientèle de Goulds.

La garantie ne couvre pas : a) les frais de main-d'oeuvre ou de transport ni les frais connexes encourus par le détaillant ; b) les frais de réinstallation de l'équipement réparé ; c) les frais de réinstallation de l'équipement de remplacement ; d) les dommages indirects de quelque nature que ce soit ; e) ni les pertes découlant de la panne.

Aux fins de la présente garantie, les termes ci-dessous sont définis comme suit : 1) « Distributeur » signifie une personne, une société de personnes, une société de capitaux, une association ou autre entité juridique servant d'intermédiaire entre Goulds et le détaillant pour les achats, les consignations ou les contrats de vente des pompes en question. 2) « Détaillant » veut dire une personne, une société de personnes, une société de capitaux, une association ou autre entité juridique dont les activités commerciales sont la vente ou la location de pompes à des clients. 3) « Client » signifie une entité qui achète ou loue les pompes en question chez un détaillant. Un « client » peut être une personne, une société de personnes, une société de capitaux, une société à responsabilité limitée, une association ou autre entité juridique se livrant à quelque activité que ce soit.

CETTE GARANTIE SE RAPPORTE AU DÉTAILLANT SEULEMENT.

8.2. Frame Mounted Units:

8.2.1. Bearing frame should be regreased every 2,000 hours or 3 month interval, whichever occurs first. Use a #2 sodium or lithium based grease. Fill until grease comes out of relief fittings, or lip seals, then wipe off excess.

8.2.2 Follow motor and coupling manufacturers' lubrication instructions.

8.2.3. Alignment must be rechecked after any maintenance work involving any disturbance of the unit.

9. Disassembly:

Complete disassembly of the unit will be described. Proceed only as far as required to perform the maintenance work needed.

9.1. Turn off power.

9.2. Drain system. Flush if necessary.

9.3. Close-Coupled Units: Remove motor hold-down bolts.

Frame-Mounted Units Remove coupling, spacer, coupling guard and frame hold-down bolts.

9.4. Disassembly of Liquid End:

9.4.1. Remove casing bolts (370).

9.4.2. Remove back pull-out assembly from casing (100).

9.4.3. Unscrew impeller bolt (198) with a socket wrench.

CAUTION

Do not insert screwdriver between impeller vanes to prevent rotation.

It may be necessary to use a strap wrench around the impeller if impacting the socket wrench will not loosen the impeller bolt. Hold shaft on frame mounted units.

9.4.4. Remove impeller washer (199).

9.4.5. Use two pry bars, 180 degrees apart, to remove the impeller (101) from shaft.

9.4.6. Remove impeller key (178) and seal spring.

9.4.7. Remove mechanical seal (383) rotating member by using two pry bars, 180 degrees apart. Gently break the bond between the shaft sleeve (126) and the rubber part of the mechanical seal by wedging.

9.4.8. Remove mechanical seal stationary seat by unbolting the adapter (108) from the motor or bearing frame and pushing the seat and rubber cup from the motor side. Adapters for close coupled and frame mounted units are the same.

On all-bronze units a separate seal housing (not illustrated) is used. Unbolt the seal housing from the adapter and remove the stationary seat as explained previously.

9.4.9. Shaft sleeve is bonded and sealed to the shaft with locking compound (Loctite 271, or equal). The bond must be broken before removal can be attempted. Break bond by heating the sleeve with a torch to about 250°F to 300°F. Pull off sleeve.

9.4.10. Casing wear rig (103) and/or seal housing wear ring (203) is removed by drilling a hole about the size of the ring thickness axially to relieve tension. Chisel off the ring toward center.

9.5. Disassembly of Bearing Frame:

9.5.1. Remove bearing cover (134).

9.5.2. Remove shaft assembly from frame (228).

9.5.3. Remove lip seals (333A) from bearing frame and bearing cover.

9.5.4. Straighten tang in lockwasher (382). Remove locknut (136) and lockwasher.

9.5.5. Use bearing puller or arbor press to remove ball bearings (112 & 168).

10. Reassembly:

10.1. All parts should be cleaned before assembly.

10.2. Refer to parts list to identify required replacement items. Specify pump index number when ordering parts.

10.3. Reassembly is the reverse of disassembly.

10.4. Observe the following when reassembling the bearing frame:

10.4.1. Replace lip seals if worn or damaged.

10.4.2. Replace ball bearings if loose, rough or noisy when rotated.

10.4.3. Check shaft for runout at the sleeve area. Maximum permissible is .002" T.I.R.

10.5. Observe the following when reassembling the liquid-end:

10.5.1. Shaft sleeve is locked and sealed against the shaft with locking compound. Shaft and sleeve bore must be clean and oil free. Apply Loctite #271 (Goulds part no. AL2172), or equal, on shaft where sleeve fits. Slide shaft sleeve over shaft, twisting back and forth a couple of times to evenly spread the compound.

CAUTION

Sleeve must seat against shaft shoulder. Let cure according to instructions. Wipe off uncured excess compound.

10.5.2. All mechanical seal components must be in good condition or leakage may result. Replacement of complete seal assembly, whenever seal has been removed, is good standard practice.

It is permissible to use a light lubricant, such as glycerine, for the mechanical seal seat and on the shaft to facilitate assembly. Do not contaminate the mechanical seal sealing faces with lubricant.

10.5.3. If wear ring is being replaced, use no lubricants on the metal-to-metal fit when pressing in the replacement.

10.5.4. Use a new impeller bolt.

10.5.5. Inspect seal housing O-ring (513) and replace if damaged.

10.6. Check reassembled unit for binding. Correct as required.

11. Trouble Shooting Chart:

MOTOR NOT RUNNING:

(See Cases 1 thru 6)

LITTLE OR NO LIQUID DELIVERED:

(See Cases 7 thru 17)

POWER CONSUMPTION TOO HIGH:

(See Cases 4, 17, 18, 19, 22)

EXCESSIVE NOISE AND VIBRATION:

(See Cases 4, 6, 9, 13, 15, 16, 18, 20, 21, 22)

PROBABLE CAUSE:

1. Tripped thermal protector
2. Open circuit breaker
3. Blown fuse
4. Rotating parts binding
5. Motor wired improperly
6. Defective motor
7. Not primed
8. Discharge plugged or valve closed
9. Incorrect rotation
10. Foot valve too small or suction not submerged
11. Low voltage
12. Phase loss
13. Air or gases in liquid
14. System head too high
15. NPSHA too low:
Suction lift too high or friction losses excessive. Check with vacuum gauge
16. Impeller worn or plugged
17. Incorrect impeller diameter
18. Head too low causing excessive flow rate
19. Viscosity or specific gravity too high
20. Worn bearings
21. Pump or piping loose
22. Pump and motor misaligned

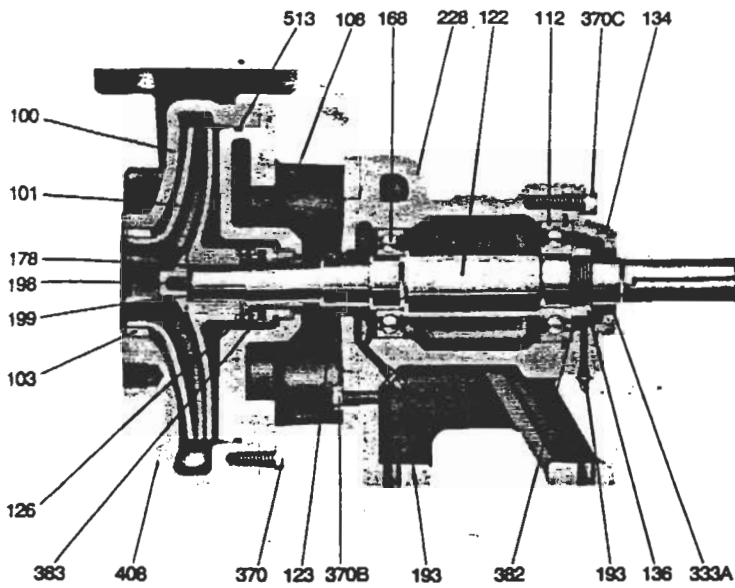

Model 3756

AISI 1045 Steel
Motor shaft extension
(Typical)

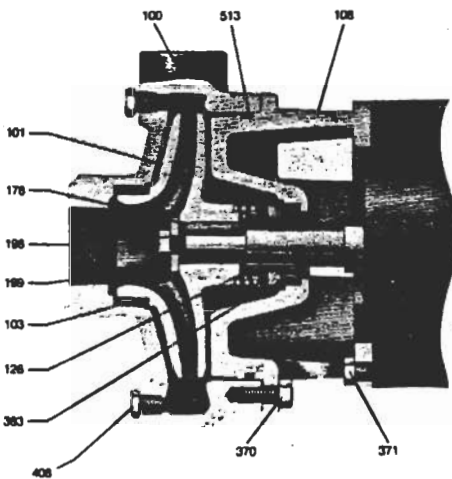

Model 3656



Back Wear Ring

Materials of Construction

Liquid End Components											
Item No.	Part Name	Material									
		All Iron		Bronze Fitted							
100	Casing	1001	1001								
101	Impeller		1102								
103	Casing Wear Ring		1102								
108	Adapter/Seal Housing		1001								
203	Back Wear Ring		1102								
184	Seal Housing	(1-pc. w/adapter) 1102									
126	Shaft Sleeve	AISI Type 300 Series Stainless Steel									
178	Impeller Key										
198	Impeller Bolt										
199	Impeller Washer										
370	Hex Head Screw (Adapter to Case)	Steel SAE 1200 Grade 5									
371	Hex Head Cap Screw (Adapter to Motor)										
John Crane Type 21											
383	Mechanical Seal	Service	Rotary	Stationary	Elastomers	Metal Parts					
	STD	General		Ceramic	Buna	Type 316 S.S.					
	OPT.	Hi-Temp.	Carbon	Ni-Resist	EPR						
	OPT.	Chem. Duty		Ceramic	Viton						
408	Pipe Plug 1/4" or 3/8"	Steel		Brass							
513	O-Ring	Buna-N									
Power End Components											
108	Adapter	Cast Iron ASTM A48 CL20									
228	Bearing Frame										
134	Bearing Cover										
122	Pump Shaft						Steel ASTM A108/SAE 1200 Series				
168	Ball Bearing (Outboard)										
112	Ball Bearing (Inboard)										
136	Locknut, Bearing										
382	Lock Washer, Bearing										
370B	Hex Head Cap Screw (Adapter to Bearing Frame)										
370C	Hex Head Cap Screw (Bearing Frame to Cover)										
333A	Lip Seal	Buna-N									
193	Grease Fitting	Steel									
123	V-Ring Deflector	Buna-N									
Materials of Construction	Material Code		Engineering Standard								
	1001		Cast Iron ASTM A48 CL20								
	1102		Bronze ASTM B584								

Goulds Limited Warranty

This warranty applies to all water systems pumps and related accessories manufactured and/or supplied by Goulds. Any part or parts found to be defective within the warranty period shall be replaced at no charge to the buyer or any subsequent owner during the warranty period. The warranty period shall exist for a period of twelve (12) months from date of installation or eighteen months from the date of manufacture, whichever period is shorter. A consumer who believes that a warranty claim exists must contact the authorized Goulds dealer from whom the equipment was originally purchased and furnish complete details regarding the claim. The dealer is authorized to adjust any warranty claims utilizing Goulds Customer Relations Department and its distributor organization.

This warranty excludes: (a) Labor, transportation and related costs incurred by the consumer to make the allegedly defective equipment available to the dealer for inspection. (b) Re-installation costs of repaired equipment. (c) Re-installation costs of replacement equipment. (d) Consequential damages of any kind.

Installation, Operation and Maintenance Instructions

Model NPE/ NPE-F

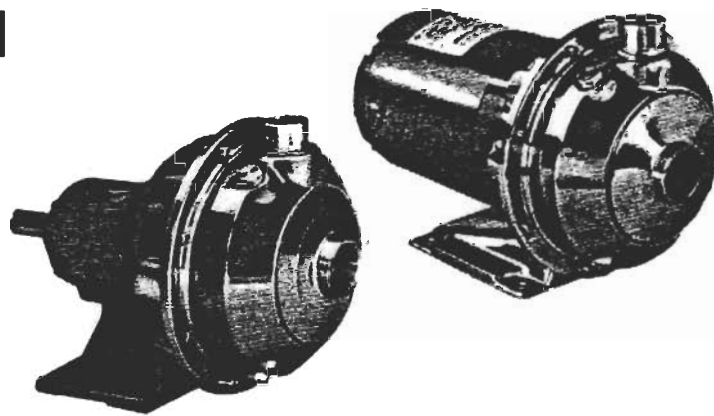

DESCRIPTION & SPECIFICATIONS:

The Models NPE (close-coupled) and NPE-F (frame-mounted) are end suction, single stage centrifugal pumps for general liquid transfer service, booster applications, etc. Liquid-end construction is all AISI Type 304 stainless steel, stamped and welded. Impellers are fully enclosed, non-trimable to intermediate diameters. Casings are fitted with a diffuser for efficiency and for negligible radial shaft loading.

Close-coupled units have NEMA 48J or 56J motors with C-face mounting and threaded shaft extension. Frame-mounted units can be coupled to motors through a spacer coupling, or belt driven.

1. Important:

1.1. Inspect unit for damage. Report any damage to carrier/dealer immediately.

1.2. Electrical supply must be a separate branch circuit with fuses or circuit breakers, wire sizes, etc., per National and Local electrical codes. Install an all-leg disconnect switch near pump.

CAUTION

Always disconnect electrical power when handling pump or controls.

1.3. Motors must be wired for proper voltage. Motor wiring diagram is on motor nameplate. Wire size must limit maximum voltage drop to 10% of nameplate voltage at motor terminals, or motor life and pump performance will be lowered.

1.4. Always use horsepower-rated switches, contactor and starters.

1.5. Motor Protection

1.5.1. Single-phase: Thermal protection for single-phase units is sometimes built in (check nameplate). If no built-in protection is provided, use a contactor with a proper overload. Fusing is permissible.

1.5.2. Three-phase: Provide three-leg protection with properly sized magnetic starter and thermal overloads.

1.6. Maximum Operating Limits:

Liquid Temperature: 212 F (100 C) with standard seal.
250 F (120 C) with optional high temp seal.
Pressure: 75 PSI.
Starts Per Hour: 20, evenly distributed.

1.7. Regular inspection and maintenance will increase service life. Base schedule on operating time. Refer to Section 8.

2. Installation:

2.1. General

2.1.1. Locate pump as near liquid source as possible (below level of liquid for automatic operation).

2.1.2. Protect from freezing or flooding.

2.1.3. Allow adequate space for servicing and ventilation.

2.1.4. All piping must be supported independently of the pump, and must "line-up" naturally.

CAUTION

Never draw piping into place by forcing the pump suction and discharge connections.

2.1.5. Avoid unnecessary fittings. Select sizes to keep friction losses to a minimum.

2.2. Close-Coupled Units:

2.2.1. Units may be installed horizontally, inclined or vertically.

CAUTION

Do not install with motor below pump. Any leakage or condensation will affect the motor.

2.2.2. Foundation must be flat and substantial to eliminate strain when tightening bolts. Use rubber mounts to minimize noise and vibration.

2.2.3. Tighten motor hold-down bolts before connecting piping to pump.

2.3. Frame-Mounted Units:

2.3.1. Bedplate must be grouted to a foundation with solid footing. Refer to Fig. 1.

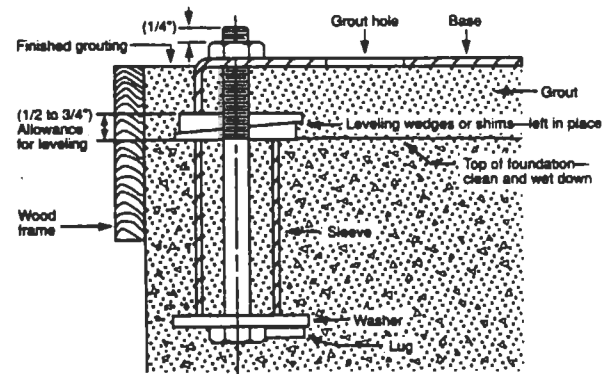

Figure 1

2.3.2. Place unit in position on wedges located at four points (two below approximate center of driver and two below approximate center of pump). Adjust wedges to level unit. Level or plumb suction and discharge flanges.

2.3.3. Make sure bedplate is not distorted and final coupling alignment can be made within the limits of movement of motor and by shimming, if necessary.

2.3.4. Tighten foundation bolts finger tight and build dam around foundation. Pour grout under bedplate making sure the areas under pump and motor feet are filled solid. Allow grout to harden 48 hours before fully tightening foundation bolts.

2.3.5. Tighten pump and motor hold-down bolts before connecting the piping to pump.

3. Suction Piping:

3.1. Low static suction lift and short, direct, suction piping is desired. For suction lift over 10 feet and liquid temperatures over 120 F, consult pump performance curve for Net Positive Suction Head Required.

3.2. Suction pipe must be at least as large as the suction connection of the pump. Smaller size will degrade performance.

3.3. If larger pipe is required, an eccentric pipe reducer (with straight side up) must be installed at the pump.

3.4. Installation with pump below source of supply:

3.4.1. Install full flow isolation valve in piping for inspection and maintenance.

CAUTION

Do not use suction isolation valve to throttle pump.

3.5. Installation with pump above source of supply:

3.5.1. Avoid air pockets. No part of piping should be higher than pump suction connection. Slope piping upward from liquid source.

3.5.2. All joints must be airtight.

3.5.3. Foot valve to be used only if necessary for priming, or to hold prime on intermittent service.

3.5.4. Suction strainer open area must be at least triple the pipe area.

3.6. Size of inlet from liquid source, and minimum submergence over inlet, must be sufficient to prevent air entering pump through vortexing. See Figs. 2-5

3.7. Use 3-4 wraps of Teflon tape to seal threaded connections.

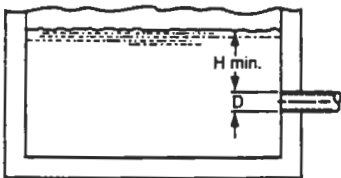

Figure 2

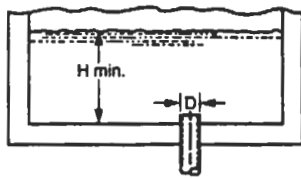

Figure 3

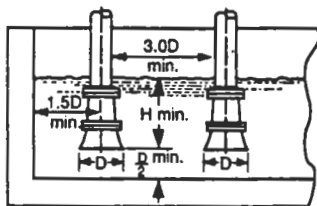

Figure 4

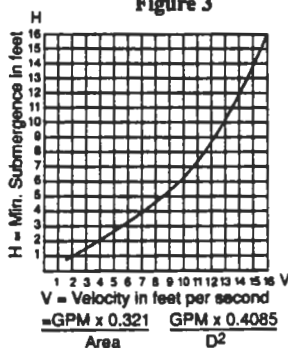

Figure 5

4. Discharge Piping:

4.1. Arrangement must include a check valve located between a gate valve and the pump. The gate valve is for regulation of capacity, or for inspection of the pump or check valve.

4.2. If an increaser is required, place between check valve and pump.

4.3. Use 3-4 wraps of Teflon tape to seal threaded connections.

5. Motor-To-Pump Shaft Alignment:

5.1. Close-Coupled Units:

5.1.1. No field alignment necessary.

5.2. Frame-Mounted Units:

5.2.1. Even though the pump-motor unit may have a factory alignment, this could be disturbed in transit and must be checked prior to running. See Fig. 6.

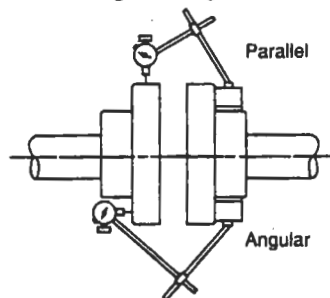

Figure 6

5.2.2. Tighten all hold-down bolts before checking the alignment.

5.2.3. If re-alignment is necessary, always move the motor. Shim as required.

5.2.4. Parallel misalignment - shafts with axis parallel but not concentric. Place dial indicator on one hub and rotate this hub 360 degrees while taking readings on the outside diameter of the other hub. Parallel alignment occurs when Total Indicator Reading is .005", or less.

5.2.5. Angular misalignment - shafts with axis concentric but not parallel. Place dial indicator on one hub and rotate this hub 360 degrees while taking readings on the face of the other hub. Angular alignment is achieved when Total Indicator Reading is .005", or less.

5.2.6. Final alignment is achieved when parallel and angular requirements are satisfied with motor hold-down bolts tight.

CAUTION

Always recheck both alignments after making any adjustment.

6. Rotation:

6.1. Correct rotation is right-hand (clockwise when viewed from the motor end). Switch power on and off quickly. Observe shaft rotation. To change rotation:

6.1.1. Single-phase motor: Non-reversible.

6.1.2. Three-phase motor: Interchange any two power supply leads.

7. Operation:

7.1. Before starting, pump must be primed (free of air and suction pipe full of liquid) and discharge valve partially open.

CAUTION

Pumped liquid provides lubrication. If pump is run dry, rotating parts will seize and mechanical seal will be damaged. Do not operate at or near zero flow. Energy imparted to the liquid is converted into heat. Liquid may flash to vapor. Rotating parts require liquid to prevent scoring or seizing.

7.2. Make complete check after unit is run under operating conditions and temperature has stabilized. Check for expansion of piping. On frame-mounted units coupling alignment may have changed due to the temperature differential between pump and motor. Recheck alignment.

8. Maintenance:

8.1. Close-Coupled Unit. Ball bearings are located in and are part of the motor. They are permanently lubricated. No greasing required.

8.2. Frame-Mounted Units:

8.2.1. Bearing frame should be regreased every 2,000 hours or 3 month interval, whichever occurs first. Use a #2 sodium or lithium based grease. Fill until grease comes out of relief fittings, or lip seals, then wipe off excess.

8.2.2. Follow motor and coupling manufacturers' lubrication instructions.

8.2.3. Alignment must be rechecked after any maintenance work involving any disturbance of the unit.

9. Disassembly:

Complete disassembly of the unit will be described. Proceed only as far as required to perform the maintenance work needed.

9.1. Turn off power.

9.2. Drain system. Flush if necessary.

9.3. Close-Coupled Units: Remove motor hold-down bolts.

Frame-Mounted Units: Remove coupling, spacer, coupling guard and frame hold-down bolts.

9.4. Disassembly of Liquid End:

9.4.1. Remove casing bolts (370).

9.4.2. Remove back pull-out assembly from casing (100).

9.4.3. Remove impeller locknut (304).

CAUTION

Do not insert screwdriver between impeller vanes to prevent rotation of close-coupled units. Remove cap at opposite end of motor. A screwdriver slot or a pair of flats will be exposed. Using them will prevent impeller damage.

9.4.4. Remove impeller (101) by turning counter-clockwise when looking at the front of the pump. Protect hand with rag or glove.

CAUTION

Failure to remove the impeller in a counter-clockwise direction may damage threading on the impeller, shaft or both.

9.4.5. With two pry bars 180 degrees apart and inserted between the seal housing (184) and the motor adapter (108), carefully separate the two parts. The mechanical seal rotary unit (383) should come off the shaft with the seal housing.

9.4.6. Push out the mechanical seal stationary seat from the motor side of the seal housing.

9.5. Disassembly of Bearing Frame:

9.5.1. Remove bearing cover (109).

9.5.2. Remove shaft assembly from frame (228).

9.5.3. Remove lip seals (138 & 139) from bearing frame and bearing cover if worn and are being replaced.

9.5.5. Use bearing puller or arbor press to remove ball bearings (112 & 168).

10. Reassembly:

10.1. All parts should be cleaned before assembly.

10.2. Refer to parts list to identify required replacement items. Specify pump index or catalog number when ordering parts.

10.3. Reassembly is the reverse of disassembly.

10.4. Observe the following when reassembling the bearing frame:

10.4.1. Replace lip seals if worn or damaged.

10.4.2. Replace ball bearings if loose, rough or noisy when rotated.

10.4.3. Check shaft for runout. Maximum permissible is .002" T.I.R.

10.5. Observe the following when reassembling the liquid-end:

10.5.1. All mechanical seal components must be in good condition or leakage may result. Replacement of complete seal assembly, whenever seal has been removed, is good standard practice.

It is permissible to use a light lubricant, such as glycerin, to facilitate assembly. Do not contaminate the mechanical seal faces with lubricant.

10.5.2. Inspect casing O-ring (513) and replace if damaged. This O-ring may be lubricated with petroleum jelly to ease assembly.

10.5.3. Inspect guidevane O-ring (349) and replace if worn.

CAUTION

Do not lubricate guidevane O-ring (349). Insure it is not pinched by the impeller on reassembly.

10.6. Check reassembled unit for binding. Correct as required.

10.7. Tighten casing bolts in a star pattern to prevent O-ring binding.

11. Trouble Shooting Chart:

MOTOR NOT RUNNING

(See causes 1 thru 6)

LITTLE OR NO LIQUID DELIVERED:

(See causes 7 thru 17)

POWER CONSUMPTION TOO HIGH:

(See causes 4, 17, 18, 19, 22)

EXCESSIVE NOISE AND VIBRATION:

(See causes 4, 6, 9, 13, 15, 16, 18, 20, 21, 22)

PROBABLE CAUSE:

1. Tripped thermal protector
2. Open circuit breaker
3. Blown fuse
4. Rotating parts binding
5. Motor wired improperly
6. Defective motor
7. Not primed
8. Discharge plugged or valve closed
9. Incorrect rotation
10. Foot valve too small, suction not submerged, inlet screen plugged.
11. Low voltage
12. Phase loss (3-phase only)
13. Air or gasses in liquid
14. System head too high
15. NPSHA too low:
Suction lift too high or suction losses excessive. Check with vacuum gauge.
16. Impeller worn or plugged
17. Incorrect impeller diameter
18. Head too low causing excessive flow rate
19. Viscosity or specific gravity too high
20. Worn bearings
21. Pump or piping loose
22. Pump and motor misaligned

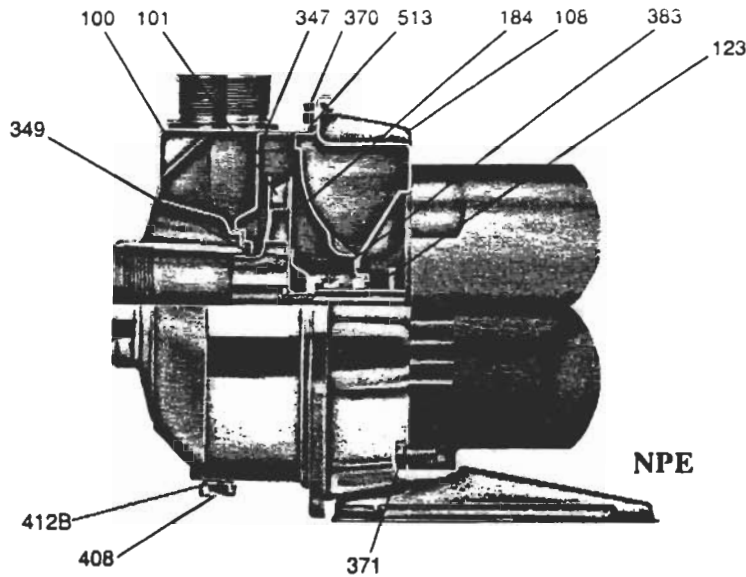

NPE

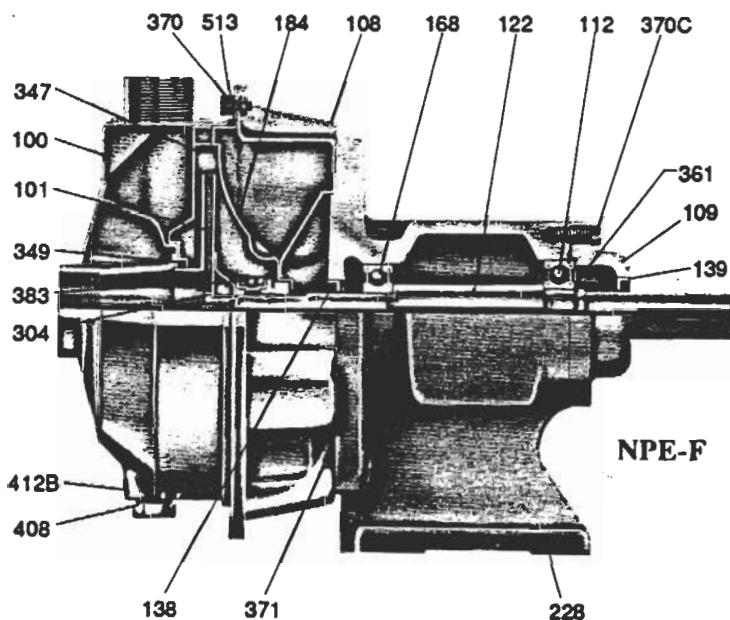

NPE-F

Liquid End Components		
Item No.	Description	Materials
100	Casing	AISI 304 Stainless Steel
101	Impeller	
184	Seal Housing	
304	Impeller Locknut	
347	Guidevane	
349	O-Ring, Guidevane	Buna-N
370	Socket Hd. Screws, Casing	AISI 304 S.S.
383	Mechanical Seal	** see chart
408	Drain & Vent Plug, Casing	AISI 304 S.S.
412B	O-Ring, Drain & Vent Plug	Buna-N
513	O-Ring, Casing	Buna-N
Power End Components		
108	Adapter	AISI 304 S.S.
109	Bearing Cover	Cast Iron
112	Ball Bearing (Outboard)	Steel
122	Shaft	AISI 303 S.S.
138	Lip Seal (Inboard)	Buna/Steel
139	Lip Seal (Outboard)	Buna/Steel
168	Ball Bearing (Inboard)	Steel
228	Bearing Frame	Cast Iron
361	Snap Ring	Steel
370C	Hex. Hd. Cap Screw, Brg. Cvr.	Plated Steel
371	Hex. Hd. Cap Screw, Adapter	Plated Steel

**Mechanical Seals—Item 383						
Part No.	Service	Rotary	Stationary	Elastomer	Metal Parts	Crane Type
10K46	Standard	Carbon	Ceramic	Buna	18-8 S.S.	21
10K18	Option-High Temp.		Ni-Resist	EPR		
10K24	Option-Chemical Duty		Ceramic	Viton		
10K55	Option-High Temp.		Tungsten			
10K29	Option-Severe Duty		Silicon Carbon	Buna		

GOULDS LIMITED WARRANTY

This warranty applies to all water systems pumps manufactured by Goulds.

Any part or parts found to be defective within the warranty period shall be replaced at no charge to the dealer during the warranty period. The warranty period shall exist for a period of twelve (12) months from date of installation or eighteen (18) months from date of manufacture, whichever period is shorter.

A dealer who believes that a warranty claim exists must contact the authorized Goulds distributor from whom the pump was purchased and furnish complete details regarding the claim. The distributor is authorized to adjust any warranty claims utilizing the Goulds Customer Service Department.

The warranty excludes:

- Labor, transportation and related costs incurred by the dealer;
- Reinstallation costs of repaired equipment;
- Reinstallation costs of replacement equipment;
- Consequential damages of any kind; and,
- Reimbursement for loss caused by interruption of service.

For purposes of this warranty, the following terms have these definitions:

- "Distributor" means any individual, partnership, corporation, association, or other legal relationship that stands between Goulds and the dealer in purchases, consignments or contracts for sale of the subject pumps.
- "Dealer" means any individual, partnership, corporation, association, or other legal relationship which engages in the business of selling or leasing pumps to customers.
- "Customer" means any entity who buys or leases the subject pumps from a dealer. The "customer" may mean an individual, partnership, corporation, limited liability company, association or other legal entity which may engage in any type of business.

THIS WARRANTY EXTENDS TO THE DEALER ONLY.

Instrucciones De Instalación, Operación Y Mantenimiento

Modelo NPE/ NPE-F

DESCRIPCIÓN Y ESPECIFICACIONES:

Los modelos NPE (compacto) y NPE-F (montado en marco) son bombas centrífugas de una etapa, de succión axial para el servicio de transferencia de líquidos en general, aplicaciones de refuerzo de presión, etc. La construcción del extremo sumergido es toda de AISI (Instituto Norteamericano del Hierro y el Acero) de acero inoxidable Tipo 304, estampada y soldada. Los impulsores son totalmente cerrados, y no se pueden recortar a diámetros intermedios. Las carcasas están equipadas con un difusor para eficiencia y que las cargas radiales sean negligibles en el eje.

Las unidades compactas tienen motores NEMA 48J o 561, con montaje de cara C y extensión roscada del eje. Las unidades montadas en marco se pueden acoplar a los motores a través de un espaciador de acoplamiento, o ser accionadas por correa.

1. Importante:

1.1. Inspeccione si la unidad tiene daños. Informe inmediatamente de cualquier daño al transportista o al agente.

1.2. La alimentación eléctrica debe ser un circuito separado con los fusibles o interruptores automáticos, tamaños de alambres, etc., de acuerdo con los Códigos Eléctricos Nacional y Local. Instale un interruptor de desconexión en todos los alambres cerca de la bomba.

PRECAUCIÓN

Siempre desconecte la corriente eléctrica cuando maneje la bomba o los controles.

1.3. El cableado de los motores debe ser adecuado para la tensión. El diagrama del cableado del motor está en la placa del fabricante del motor. El tamaño de los alambres debe limitar la máxima caída de tensión al 10% de la tensión de la placa del fabricante en los terminales del motor, o la vida del motor y el rendimiento de la bomba se disminuirán.

1.4. Siempre use interruptores, contactores y arrancadores con clasificación de potencia nominal.

1.5. Protección del motor

1.5.1. Monofásico: La protección térmica en las unidades monofásicas a veces está incorporada (verifique la placa del fabricante). Si no se provee protección incorporada, use un contactor con la sobrecarga apropiada. Se permite usar fusible.

1.5.2. Trifásico: Proporcione protección en los tres alambres con arrancador magnético de tamaño apropiado y sobrecargas térmicas.

1.6. Límites máximos de operación:

Temperatura del líquido: 210°F (100°C) con sello estándar
 250°F (120°C) con sello de alta temperatura opcional

Presión: 75 lib/pulg²
 Arranques por hora: 20, distribuidos uniformemente

1.7. La inspección y el mantenimiento regular aumentarán la vida de servicio. Establezca el programa de acuerdo al tiempo de funcionamiento. Refiérase a la Sección 8.

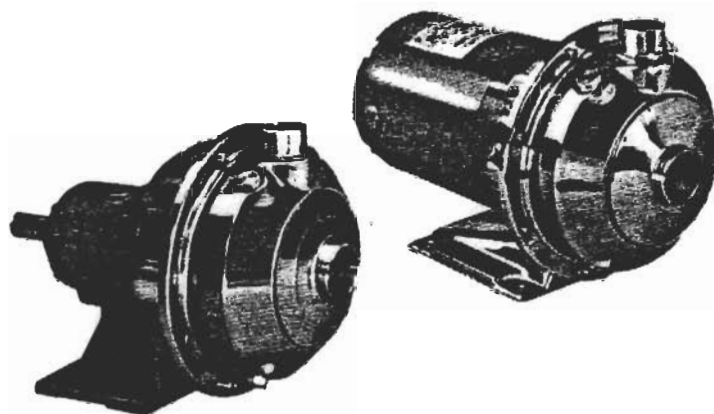

2. Instalación:

2.1. Generalidades

2.1.1. Coloque la bomba tan cerca de la fuente del líquido como sea posible (debajo del nivel del líquido para operación automática).

2.1.2. Proteja de la congelación o inundación.

2.1.3. Deje espacio libre adecuado para el servicio y la ventilación.

2.1.4. Toda la tubería debe estar soportada independientemente de la bomba, y debe "estar alineada" naturalmente.

PRECAUCIÓN

Nunca estire la tubería en el lugar forzando las conexiones de la succión y descarga de la bomba.

2.1.5. Evite los accesorios innecesarios. Seleccione los tamaños para mantener las pérdidas de fricción al mínimo.

2.2. Unidades compactas:

2.2.1. Estas unidades pueden instalarse horizontalmente, inclinadas o verticalmente.

PRECAUCIÓN

No instale con el motor debajo de la bomba. Cualquier fuga o condensación afectará al motor.

2.2.2. La cimentación debe ser plana y substancial para eliminar las deformaciones cuando se aprieten los pernos. Use montajes de goma para minimizar el ruido y las vibraciones.

2.2.3. Apriete los pernos de sujeción del motor antes de conectar la tubería a la bomba.

2.3. Unidades montadas en marco:

2.3.1. La placa de base debe estar unida, con lechada, a una cimentación con zapata sólida. Vea la Fig. 1.



Figura 1

2.3.2. Coloque la unidad en posición sobre las cuñas ubicadas en cuatro puntos, (dos aproximadamente debajo del centro del motor y dos aproximadamente debajo del centro de la bomba). Ajuste las cuñas para nivelar la unidad. Nivele o ponga vertical las bridas de succión y de descarga.

2.3.3. Asegúrese de que la placa de base no esté distorsionada y se pueda hacer la alineación final del acoplamiento dentro de los límites del movimiento del motor y poniendo calzas, si fuera necesario.

2.3.4. Apriete con los dedos los pernos de la cimentación y construya la presa alrededor de la cimentación. Vierta la lechada debajo de la placa de base asegurándose de que las áreas debajo de la bomba y de la pata del motor estén bien rellenas. Deje que la lechada fragüe por 48 horas antes de apretar totalmente los pernos de la cimentación.

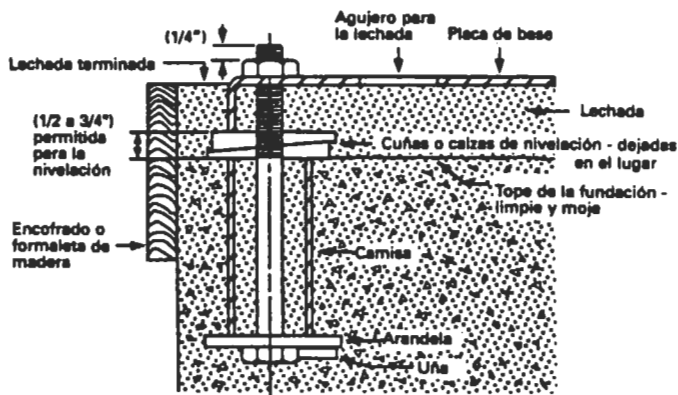
2.3.5. Apriete los pernos de sujeción de la bomba y del motor antes de conectar la tubería a la bomba.

3. Tubería de succión:

3.1. Es deseable tener una tubería de succión directa, corta y una altura de aspiración estática baja. Para alturas de succión superiores a 10 pies y temperaturas del líquido superiores a 120°F, consulte la curva de rendimiento de la bomba para ver la Altura de Succión Positiva Neta requerida.

3.2. La tubería de succión debe ser por lo menos tan grande como la conexión de succión a la bomba. Un tamaño más pequeño disminuirá el rendimiento.

3.3. Si se requiere una tubería más grande, se debe instalar una reducción excéntrica (con el lado recto hacia arriba), en la bomba.

3.4. Instalación con la bomba abajo de la fuente de alimentación:

3.4.1. Instale en la tubería una válvula de aislación de todo el caudal para la inspección y mantenimiento.

PRECAUCIÓN

No use la válvula de aislación de succión para estrangular la bomba.

3.5. Instalación con la bomba arriba de la fuente de alimentación:

3.5.1. Evite las bolsas de aire. Ninguna de las partes de la tubería debe ser más alta que la conexión de succión de la bomba. Incline la tubería hacia arriba, partiendo de la fuente del líquido.

3.5.2. Todas las juntas deben ser estancas.

3.5.3. La válvula de pie debe usarse solamente si es necesario para el cebado o para mantener el cebado durante el servicio intermitente.

3.5.4. El área abierta del colador de succión debe ser por lo menos el triple del área de la tubería.

3.6. El tamaño de la entrada de la fuente del líquido, y la inmersión mínima sobre la succión, deben ser suficientes para impedir la entrada de aire a la bomba a través de vórtices. Vea las Figuras 2 a 5.

3.7. Use 3 a 4 vueltas de cinta de Teflon para sellar las conexiones roscadas.



Figura 2



Figura 3

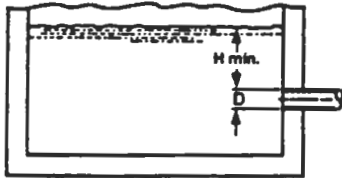

Figura 4

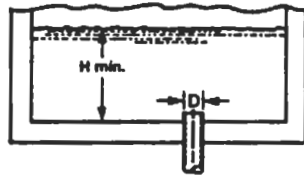

Figura 5

4. Tubería de descarga:

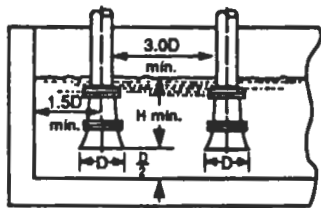
4.1. La disposición debe incluir una válvula de retención ubicada entre una válvula de compuerta y la bomba. La válvula de compuerta es para la regulación de la capacidad o para la inspección de la bomba o de la válvula de retención.

4.2. Si se requiere un aumentador, instale entre la válvula de retención y la bomba.

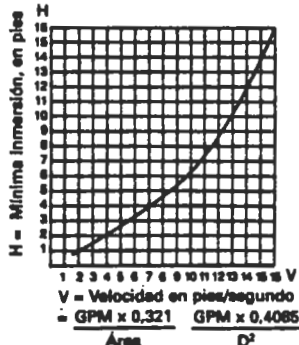
4.3. Use 3 a 4 vueltas de cinta de Teflón para sellar las conexiones roscadas.

5. Alineación del eje del motor al de la bomba:

5.1. Unidades compactas:

5.1.1. No se necesita alinear en el campo.

5.2. Unidades montadas en marco:

5.2.1. Aunque la unidad del motor y bomba pueda tener una alineación de fábrica, ésta pudo haberse alterado en tránsito y debe verificarse antes de hacer funcionar. Vea la Figura 6.



Figura 6

5.2.2. Apriete todos los pernos de sujeción antes de verificar la alineación.

5.2.3. Si es necesario realinear, siempre mueva el motor. Ponga calzas según se requiera.

5.2.4. Mala alineación paralela (ejes con ejes paralelos pero no concéntricos). Ponga el indicador de cuadrante en un cubo y gire este cubo 360° mientras hace lecturas en el diámetro exterior del otro cubo. La alineación paralela se obtiene cuando la lectura indicada total es de 0,005" (0,127 mm) o menos.

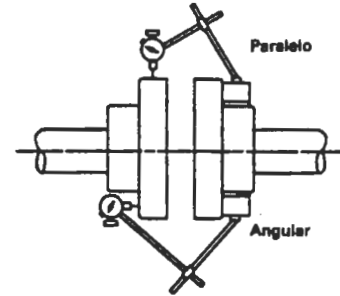
5.2.5. Mala alineación angular (ejes con ejes concéntricos pero no paralelos). Ponga el indicador de cuadrante en un cubo y gire este cubo 360° mientras hace lecturas en la cara del otro cubo. La alineación angular se obtiene cuando la lectura indicada total es de 0,005" (0,127 mm) o menos.

5.2.6. La alineación final se obtiene cuando se satisfacen los requerimientos de alineación paralela y angular, con los pernos de sujeción del motor apretados.

PRECAUCIÓN

Siempre vuelva a verificar ambas alineaciones después de hacer cualquier ajuste.

6. Rotación:

6.1. La rotación correcta es a la derecha (en sentido dextrorso cuando se mira desde el extremo del motor). Encienda y apague la corriente rápidamente. Observe la rotación del eje. Para cambiar la rotación:

6.1.1. Motores monofásicos: No reversibles.

6.1.2. Motores trifásicos: Intercambie dos cualesquiera de los conductores de alimentación de potencia.

7. Operación:

7.1. Antes de arrancar, se debe cebar la bomba (la tubería de succión llena de líquido y sin aire), y abrir parcialmente la válvula de descarga.

PRECAUCIÓN

El líquido bombeado proporciona lubricación. Si se hace funcionar la bomba en seco, las partes que giran se agarrarán y se dañará el sello mecánico. No haga funcionar con caudal muy bajo o cerca de cero. La energía impartida al líquido se convierte en calor y el líquido puede convertirse en vapor. Las partes giratorias requieren líquido para impedir la formación de estrías o el agarramiento.

7.2. Haga una verificación completa después de que haya funcionado la unidad bajo condiciones de operación y se haya estabilizado la temperatura. Verifique la expansión de la tubería. En las unidades montadas en marco la alineación del acoplamiento pudo haber cambiado debido a la diferencial de temperatura entre el motor y la bomba. Vuelva a verificar la alineación.

8. Mantenimiento:

8.1. Unidad compacta. Los cojinetes de bolas están colocados adentro y son parte del motor. Están lubricados permanentemente y no requieren engrase.

8.2. Unidades montadas en marco:

8.2.1. El marco del cojinete se debe volver a engrasar cada 2.000 horas o a intervalos de 3 meses, el que ocurra primero. Use una grasa #2 con base de sodio o litio. Llene hasta que la grasa salga de las graseras o de los sellos de reborde, luego limpie el exceso.

8.2.2. Siga las instrucciones de lubricación del fabricante del motor y del acoplamiento.

8.2.3. La alineación se debe volver a verificar después de cualquier trabajo de mantenimiento que implique alguna alteración de la unidad.

9. Desmontaje:

Se describirá el desmontaje completo de la unidad. Prosiga solamente hasta donde se requiera para realizar el trabajo de mantenimiento necesario.

9.1. Apague la alimentación eléctrica.

9.2. Drene el sistema. Lave con chorro, si es necesario.

9.3. Unidades compactas: Quite los pernos de sujeción del motor.

Unidades montadas en marco: Quite el acoplamiento, el espaciador, el resguardo del acoplamiento y los pernos de sujeción del marco.

9.4. Desmontaje del extremo sumergido:

9.4.1. Quite los pernos (370) de la carcasa.

9.4.2. Quite el conjunto de desmontaje de la caja de rodamientos de la carcasa (100).

9.4.3. Quite la tuerca de seguridad (304) del impulsor.

PRECAUCIÓN

No inserte un destornillador entre los álabes del impulsor para impedir la rotación de las unidades compactas. Quite la tapa en el lado opuesto del motor. Se expondrá una ranura del destornillador o un par de filos normales al eje. Usándolos impedirá daños al impulsor.

9.4.4. Quite el impulsor (101) girando en sentido sinistrorso mirando al frente de la bomba. Protéjase las manos con telas o guantes.

PRECAUCIÓN

No quitar el impulsor en sentido sinistrorso puede dañar las roscas en el impulsor, el eje o en ambos.

9.4.5. Con dos barras de hacer palanca separadas en 180 grados e insertadas entre el alojamiento del sello (184) y el adaptador del motor (108), cuidadosamente separe las dos partes. La unidad giratoria del sello mecánico (383) debe salir del eje con el alojamiento del sello.

9.4.6. Empuje afuera el asiento estacionario del sello mecánico, del lado del motor del alojamiento del sello.

9.5. Desmontaje del marco del cojinete:

9.5.1. Quite la tapa (109) del cojinete.

9.5.2. Quite el conjunto del eje del marco (228).

9.5.3. Quite los sellos de reborde (138 y 139) del marco del cojinete y de la tapa del cojinete si están desgastados y se están cambiando.

9.5.5. Use un extractor de cojinetes o prensa de eje para quitar los cojinetes de bolas (112 y 168).

10. Reensamble:

10.1. Todas las piezas deben limpiarse antes del montaje.

10.2. Consulte la lista de piezas para identificar las piezas necesarias para la reparación. Especifique la bomba o el número de catálogo cuando pida las piezas.

10.3. Reensamblar o volver a montar es lo contrario de desmontar.

10.4. Observe lo siguiente cuando vuelva a montar el marco del cojinete:

10.4.1. Cambie los sellos de reborde si están desgastados o dañados.

10.4.2. Cambie los cojinetes de bolas si están flojos, ásperos o ruidosos al girarlos.

10.4.3. Verifique si el eje está descentrado. El máximo permisible es una lectura de indicador total de 0,002".

10.5. Observe lo siguiente cuando vuelva a montar el extremo sumergido:

10.5.1. Todos los componentes del sello mecánico deben estar en buenas condiciones o pueden haber fugas. Es buena práctica estándar cambiar todo el conjunto del sello en cualquier momento en que se haya quitado el sello.

Se permite usar un lubricante ligero, tal como glicerina, para facilitar el montaje. No contamine las caras del sello mecánico con lubricante.

10.5.2. Inspeccione el anillo en O (513) de la carcasa y cámbielo si está dañado. Este anillo en O puede lubricarse con vaselina para facilitar el montaje.

10.5.3. Inspeccione el anillo en O (349) del álabes director y cámbielo si está desgastado.

PRECAUCIÓN

No lubrique el anillo en O (349) del álabes director. Asegúrese de que no esté pellizcado por el impulsor al volver a montar.

10.6. Verifique la unidad que volvió a montarse viendo si está agarrotada. Corrija según se requiera.

10.7. Apriete los pernos de la carcasa en un patrón de estrella para impedir que se trabe el anillo en O.

11. Investigación de averías:

MOTOR NO FUNCIONA:

(Vea las causas 1 a 6)

ENTREGA POCO O NADA DE LÍQUIDO:

(Vea las causas 7 a 17)

CONSUMO MUY ALTO DE CORRIENTE:

(Vea las causas 4, 17, 18, 19, 22)

EXCESIVO RUIDO Y VIBRACIONES:

(Vea las causas 4, 6, 9, 13, 15, 16, 18, 20, 21, 22)

CAUSA PROBABLE:

1. Protector térmico del motor disparado
2. Interruptor automático abierto
3. Fusible quemado
4. Partes giratorias agarrotadas
5. Motor mal conectado
6. Motor defectuoso
7. Bomba no cebada
8. Taponada la descarga o cerrada la válvula
9. Rotación incorrecta
10. Válvula de pie demasiado pequeña, succión no sumergida, taponada la malla de entrada
11. Tensión baja
12. Pérdida de fase (trifásico solamente)
13. Aire o gases en el líquido
14. Demasiado alta la altura o carga del sistema
15. Demasiado baja la ASPND; (altura de succión positiva neta disponible);
Demasiado alta la altura de aspiración o excesivas las pérdidas. Verifique con un calibrador de vacío.
16. Impulsor desgastado o taponado
17. Incorrecto el diámetro del impulsor
18. Demasiado baja la altura de descarga causando caudal excesivo
19. Demasiado alta la viscosidad o gravedad específica
20. Cojinetes desgastados
21. Bomba o tubería flojas
22. Bomba y motor mal alineados

Materiales de construcción

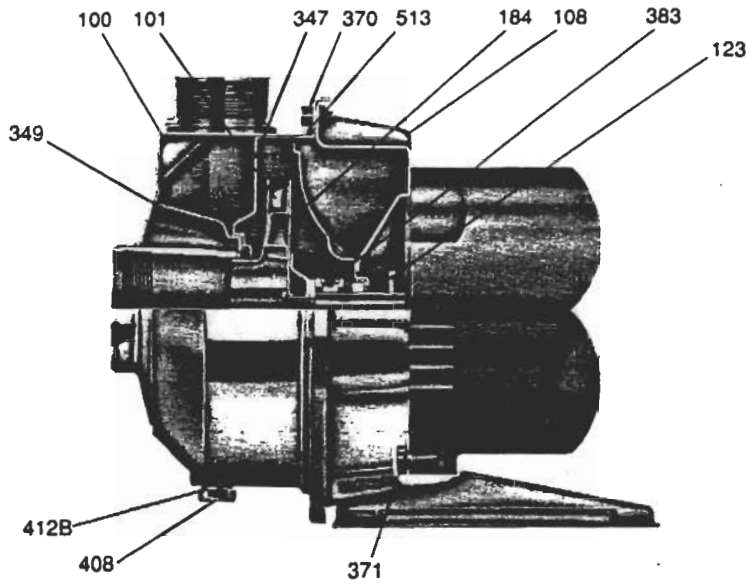

NPE

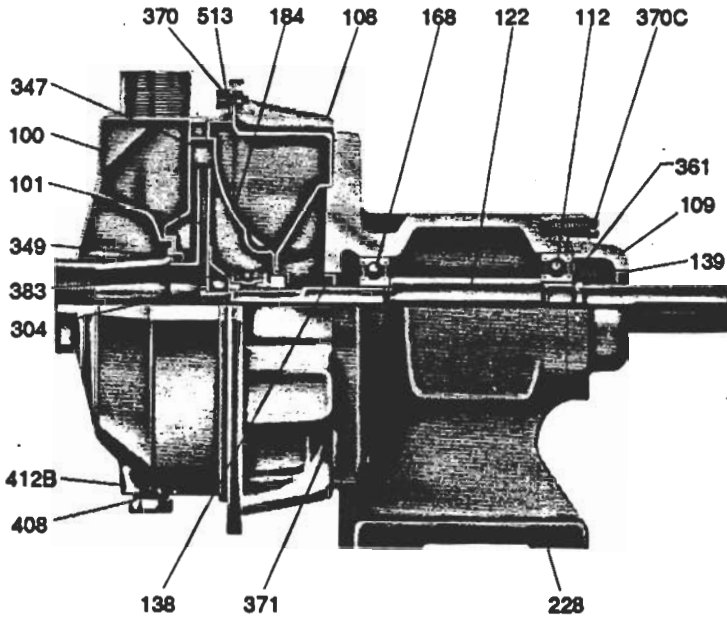

NPE-F

Componentes del extremo sumergido		
Artículo No.	Descripción	Materiales
100	Carcasa	AISI A.I. 304
101	Impulsor	
184	Alojamiento del sello	
304	Tuerca de seguridad del impulsor	
347	Álabe director	
349	Anillo en O, álabe director	Buna-N
370	Tornillos de cabeza hueca, carcasa	AISI A.I. 304
383	Sello mecánico	** vea el gráfico
408	Tapón de drenaje y ventilación, carcasa	AISI A.I. 304
412B	Anillo en O, tapón de drenaje y ventilación	Buna-N
513	Anillo en O, carcasa	Buna-N
Componentes del extremo motriz		
108	Adaptador	AISI A.I. 304
109	Tapa del cojinete	Hierro fundido
112	Cojinete de bolas (externo)	Acero
122	Eje	AISI A.I. 304
138	Sello de reborde (interno)	Buna/acero
139	Sello de reborde (externo)	Buna/acero
168	Cojinete de bolas (interno)	Acero
228	Marco del cojinete	Hierro fundido
361	Anillo de resorte	Acero
370C	Tornillo de casquete de cabeza hex., tapa cojinete	Acero enchapado
371	Tornillo de casquete de cabeza hex., adaptador	Acero enchapado

**Sellos mecánicos - Art. 383						
Pieza No.	Servicio	Giratorio	Estacionario	Elastómero	Partes metálicas	Crane tipo
10K46	Estándar	Carbono	Cerámica	Buna	18.8 S.S.	21
10K18	Alta temperatura - opcional		Resist. Ni.	EPR		
10K24	Servicio químico - opcional		Cerámica	Viton		
10K55	Alta temperatura - opcional		Tungsteno			
10K29	Servicio severo - opcional		Carbono de silicio	Buna		

GARANTÍA LIMITADA DE GOULDS

Esta garantía es aplicable a todas las bombas para sistemas de agua fabricadas por Goulds.

Toda parte o partes que resultaren defectuosas dentro del período de garantía serán reemplazadas, sin cargo para el comerciante, durante dicho período. Tal período de garantía se extiende por doce (12) meses a partir de la fecha de instalación, o dieciocho (18) meses a partir de la fecha de fabricación, cualquiera que se cumpla primero.

Todo comerciante que considere que existe lugar a un reclamo de garantía deberá ponerse en contacto con el distribuidor autorizado de Goulds del cual adquiriera la bomba, y ofrecer información detallada con respecto del reclamo. El distribuidor está autorizado a liquidar todos los reclamos por garantía a través del Departamento de Servicios a Clientes de Goulds.

La presente garantía excluye: a) La mano de obra, el transporte y los costos relacionados en los que incurra el comerciante; b) los costos de reinstalación del equipo reparado; c) los costos de reinstalación del equipo reemplazado; d) daños emergentes de cualquier naturaleza; y e) el reembolso de cualquier pérdida causada por la interrupción del servicio.

Para los fines de esta garantía, los términos "Distribuidor", "Comerciante" y "Cliente" se definen como sigue: 1) "Distribuidor" es aquel individuo, sociedad, corporación, asociación u otra entidad jurídica que opera entre Goulds y el comerciante para la compra, consignación o contratos de venta de las bombas en cuestión. 2) Comerciante es todo individuo, sociedad, corporación, asociación u otra entidad jurídica que realiza negocios de venta o alquiler-venta (leasing) de bombas a clientes. 3) "Cliente" es toda entidad que compra o que adquiere bajo la modalidad de "leasing" las bombas en cuestión de un comerciante. El término "cliente" puede significar un individuo, sociedad, corporación, sociedad de responsabilidad limitada, asociación o cualquier otra entidad jurídica con actividades en cualquier tipo de negocios.

LA PRESENTE GARANTÍA SE EXTIENDE AL COMERCIANTE ÚNICAMENTE

Directives d'installation,
d'utilisation et d'entretien

Modèles NPE et NPE-F

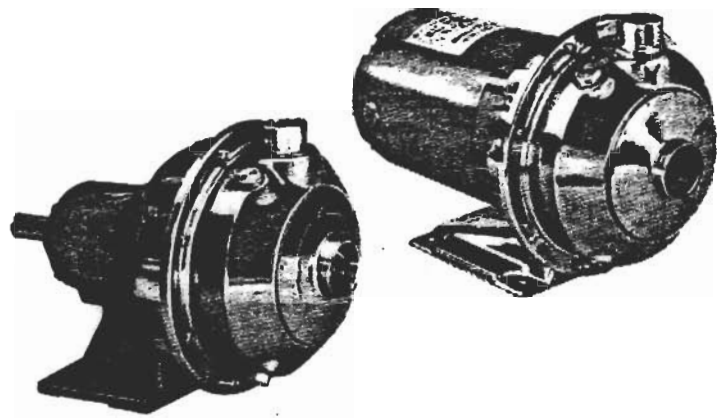

DESCRIPTION ET CARACTÉRISTIQUES

Les pompes de modèles NPE (montées sur moteur) et NPE-F (montées sur socle) sont des pompes centrifuges à un étage et à orifice d'aspiration situé à l'extrémité. Elles sont utilisées pour le transfert général de liquides, le gavage, etc. Les composants de la pompe proprement dite sont tous en inox AISI de type 304 estampé ou soudé. L'impulseur est de type fermé. On ne peut l'usiner pour en réduire le diamètre. Le corps de pompe est muni d'un diffuseur pour en améliorer l'efficacité et diminuer la charge radiale de l'arbre.

Les pompes de modèle NPE sont montées sur des moteurs NEMA 48J ou 56J au moyen d'un support (entretoise) en C. Le bout de l'arbre du moteur est fileté. Les pompes montées sur socle peuvent être reliées au moteur par un accouplement à entretoise ou par une courroie.

1. Informations importantes

- 1.1. Inspecter l'appareil et signaler immédiatement tout dommage au transporteur ou au détaillant.
- 1.2. L'alimentation en électricité doit être assurée par un circuit de dérivation distinct dont les fusibles ou les disjoncteurs, le calibre des fils, etc., sont conformes aux prescriptions du code provincial ou national de l'électricité. Poser un sectionneur tout conducteur près de la pompe.

ATTENTION

On doit toujours couper le courant lorsque l'on effectue quelque travail que ce soit sur la pompe ou les commandes.

- 1.3. Le câblage d'alimentation du moteur doit convenir à la tension de fonctionnement. Le schéma de câblage se trouve sur la plaque signalétique du moteur. Les fils doivent avoir un calibre limitant la chute de tension maximale, aux bornes du moteur, à 10 % de la valeur de tension indiquée sur la plaque signalétique, sinon la durée de vie du moteur et les performances de la pompe diminueront.

- 1.4. Il faut toujours employer des contacteurs et des démarreurs conçus pour les puissances nominales en horse-power (hp).

1.5. Protection du moteur

1.5.1. Moteurs monophasés – Ces moteurs sont parfois munis d'une protection thermique intégrée (consulter la plaque signalétique). Dans le cas contraire, utiliser un contacteur à protection appropriée contre les surcharges. Les dispositifs fusibles sont permis.

1.5.2. Moteurs triphasés – Employer une protection trois conducteurs appropriée contre les surcharges thermiques ainsi qu'un démarreur magnétique convenant à la charge électrique.

1.6. Limites d'utilisation maximales

Température du liquide: 100°C (212°F), avec joint standard;
120°C (250°F), avec joint pour hautes températures en option.

Pression: 517 kPa (75 lb/po²)

Démarrages par heure: 20, répartis uniformément

- 1.7. Une inspection et un entretien réguliers augmenteront la durée de vie de l'appareil. Établir un programme d'entretien et d'inspection basé sur le temps de fonctionnement. Voir la section 8.

2. Installation

2.1. Généralités

- 2.1.1. Placer la pompe aussi près de la source de liquide que possible, mais plus bas pour assurer l'amorçage automatique.
- 2.1.2. Protéger l'appareil contre les inondations et le gel.
- 2.1.3. Laisser assez d'espace pour l'entretien et l'aération.
- 2.1.4. La tuyauterie doit posséder ses propres supports et «s'aligner» correctement sur la pompe.

ATTENTION

Ne jamais tirer sur la tuyauterie pour la relier aux raccords d'aspiration et de refoulement.

- 2.1.5. Ne poser aucun accessoire de tuyauterie superflu. Choisir le calibre qui réduit les pertes de charge par frottement au minimum.

2.2. Pompes montées sur moteur:

- 2.2.1. Les pompes peuvent être installées sur une surface horizontale, inclinée ou verticale.

ATTENTION

Ne pas placer le moteur plus bas que la pompe afin de le protéger contre les fuites et l'eau de condensation.

- 2.2.2. L'assise doit être plane et solide pour empêcher que le serrage des boulons ne cause de contraintes. Monter l'appareil sur caoutchouc pour réduire le bruit et les vibrations au minimum.

- 2.2.3. Serrer les boulons de fixation du moteur avant de raccorder la tuyauterie à la pompe.

2.3. Pompes montées sur socle:

- 2.3.1. On doit fixer la plaque d'assise à une dalle reposant sur une semelle de fondation solide et remplir de coulis l'espace séparant la plaque et la dalle (V. fig. 1).

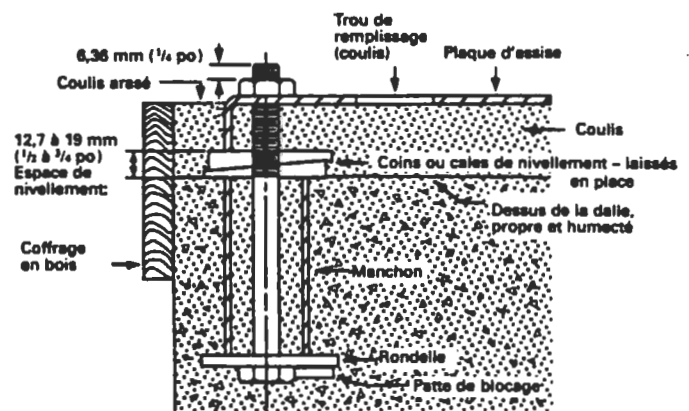

Figure 1

Paraflow Plate Heat Exchanger Instruction Manual

TABLE OF CONTENTS	Page	Page	
1.0 INTRODUCTION	2	5.0 ASSEMBLY	17
1.1 General		5.1 Handling	
1.2 Safety		5.2 Lifting	
1.3 Design		5.3 Assembling the Frame	
1.4 Receiving and Inspection		5.4 Installation of Plates	
		5.5 Installation of the Tie Bars	
		5.6 Closing Tie Bar of Frames	
		5.7 Opening Tie Bar Frame	
2.0 SAFETY INSTRUCTIONS	3	6.0 STARTUP AND OPERATION	21
2.1 General Statement		6.1 General	
2.2 Hazard Level Identification		6.2 Startup	
2.3 Operating Zone		6.3 Operation	
2.4 Installation		6.4 Shut Down	
2.5 Safety Instructions		6.5 Troubleshooting	
2.6 General Operating Safety		6.6 Refrigeration Service	
2.7 Service and Maintenance Safety			
2.8 Safety Cleaning Procedures		7.0 MAINTENANCE	25
2.9 Cleaning Paraflows Used with Refrigerants		7.1 Opening the Frame	
2.10 Cleaning Chemicals and Refrigerant Paraflows		7.2 Inspection	
		7.3 Cleaning	
		7.4 Replacement of Plates	
		7.5 Regasketing	
3.0 CONSTRUCTION	6	8.0 PARTS AND SERVICE	28
3.1 Frame		8.1 Ordering Parts	
3.2 Plates		8.2 Service	
3.3 Gaskets		8.3 Documentation	
3.4 Intermediate Connector Grids			
3.5 General Arrangement Drawing		9.0 ACCESSORIES	29
3.6 Plate Arrangement Diagram		9.1 Manual Tightening Wrenches	
		9.2 Power Tightening Equipment	
		9.3 Heat Shields	
		9.4 Hydraulic Rams	
4.0 INSTALLATION	15		
4.1 Location			
4.2 Foundations			
4.3 Space Requirements			
4.4 Connections and Piping			
4.5 Pressure Pulsation and Vibration			
4.6 Pressure / Temperature Rating			
4.7 Hydraulic Shock			
4.8 Heat Shields			
4.9 Short Term Storage			
4.10 Long Term Storage			

1.0 INTRODUCTION

1.1 General

The purpose of this manual is to provide you with the information necessary for the safe and proper installation, operation and maintenance of your APV Paraflow Plate Heat Exchanger. This will ensure many years of satisfactory performance. The manual is specific to the tie bar tightened frames. Separate publications deal with Paraflow Plate Heat Exchangers tightened by other means.

1.2 Safety

Safe installation, operation and maintenance of the APV Paraflow Plate Heat Exchanger requires proper procedures and training of all personnel. Section 2.0 Safety Instructions should be read and understood before proceeding. This section discusses general safety practices. In addition, specific hazards are indicated throughout this manual by the appropriate hazard label in bold type.

Warning:

Read and understand the entire manual before unpacking the equipment and installing it.

It is the objective of APV to clearly identify each area of potential hazard and guide workers in safe operation, service and maintenance procedures.

1.3 Design

The Paraflow is the original plate type heat exchanger designed by APV to provide maximum efficiency and cost effectiveness in handling heat transfer duties. The basic concept is two liquids flowing on either side of a thin corrugated metal plate so heat may be easily transferred between the two. The plate heat exchanger also minimizes maintenance downtime and requires little floor space compared to other types of heat transfer equipment. This equipment has many applications in a wide range of industries. Typical industries include:

Chemical	Dairy
Industrial	Beverage
Petroleum	Liquid Food
HVAC	Pharmaceutical
Refrigeration	Health Care

1.4 Receiving and Inspection

APV Paraflow Plate Heat Exchangers are assembled and inspected before shipment and properly prepared for transportation. APV cannot, however, guarantee safe arrival. Therefore, upon receipt of this equipment, check all received items against the packing list for damage or missing parts. Damage or loss should be reported immediately to the carrier.

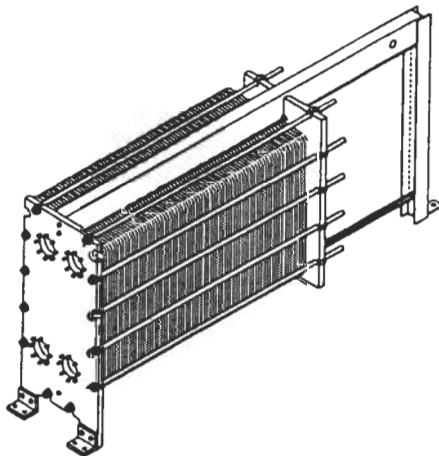

2.0 SAFETY INSTRUCTIONS

2.1 General Statement

APV Paraflow Plate Heat Exchangers are designed and manufactured with due consideration and care for generally accepted safety standards. However, like any mechanical device, the proper and safe performance of this equipment depends upon using sound and prudent operating, maintenance and servicing procedures under properly trained supervision.

For your protection, and the protection of others, learn and always follow the safety rules outlined in this section. Observe warning signs on machines and act accordingly. Form safe working habits by reading the rules and abiding by them. Keep this booklet handy and review it from time to time to refresh your understanding of the rules.

2.2 Hazard Level Identification

Definitions for identifying the various hazard levels shown on warning labels or to indicate proper safety procedures in the instruction manual are provided in the following labels.

Danger:

The use of the word "Danger" always signifies an immediate hazard with a high likelihood of severe personal injury or death if instructions, including recommended precautions, are not followed.

Warning:

The use of the word "Warning" signifies the presence of hazards or unsafe practices that could result in severe personal injury or death if instructions, including recommended precautions, are not followed.

Caution:

The use of the word "Caution" always signifies possible hazards that could result in minor injury or damage to product or property if instructions, including recommended precautions, are not followed.

2.3 Operating Zone

An operating zone should be established around all heat exchangers. A brightly painted guard rail or warning stripe should define the zone. Only the operator or other authorized personnel should be within the operating zone when machine control circuits are energized or the heat exchanger is operating. No tools or other equipment should be kept within the operating zone.

2.4 Installation

Utilities, such as water, steam, electric, air and hydraulic, should be installed by trained and authorized personnel only. Installations must comply with all applicable codes and standards, including those established by OSHA.

2.5 Safety Instructions

Before Starting a Machine

Be absolutely positive all necessary guards and safety devices are installed and operating properly. This includes heat shields or pressure relief devices.

Be sure all personnel are clear of the machine.

Remove (from the operating zone) any materials, tools or other foreign objects that could cause injury to personnel or damage the machine.

Make certain the heat exchanger is in operating condition.

Make certain all alarms, indicating lights, pressure gauges and other safety devices or indicators are in working order.

After Shutdown

Make certain all water, steam, air, hydraulic and electric utilities are turned off. Make certain all pressure in the heat exchanger is released.

2.6 General Operating Safety

Do not operate this machine until you read and understand the operating instructions and become thoroughly familiar with the machine and its operation.

Never operate a machine while a safety device or guard is removed or disconnected.

Always wear safety glasses, hats, shoes, ear protection or any other required safety equipment.

Never remove "Warning" tags that are displayed on the machine. Torn or worn labels should be replaced.

Do not start the machine until all other personnel in the area have been warned and have moved outside the operating zone.

Remove any tools or other foreign objects from the operating zone before starting.

Absolutely do not have loose clothing, neckties, necklaces or unrestrained long hair near an operating machine.

Do not wear gloves, rings, watches, bracelets or other jewelry near an operating machine.

Keep the operating zone free of obstacles that could cause a person to trip or fall towards an operating machine.

Never sit or stand on anything that might cause you to fall against the machine.

"Horseplay" around a machine at any time is dangerous and prohibited.

Know the EMERGENCY STOP procedure for the machine.

Never operate the machine above specified capacity, pressures or temperatures.

Keep alert and observe indicator lights and warnings that are displayed on the machine.

Do not operate faulty or damaged equipment. Make certain proper service and maintenance procedures have been performed.

A safe work surface should be provided around the heat exchanger, including proper guarding of elevated platforms and the design and use of ladders.

2.7 Service and Maintenance Safety

Do not service a machine until you are thoroughly qualified and familiar with the tasks to be performed.

Never operate any valves, pumps or controls while persons are performing maintenance on the machine.

Do not bypass a safety device.

Always use the proper tool for the job.

Do not enter a confined space without first checking for toxic fumes and providing standby personnel on the site.

2.8 Safe Cleaning Procedures

Manual Cleaning Procedures

Do not use toxic or flammable solvents to clean a machine.

Always clean up spills around machine as soon as possible.

Never attempt to clean a machine while it is operating.

Cleaning In Place Procedures

Make certain all connections in the cleaning circuit are tight to avoid contact with hot water or cleaning solutions.

When the cleaning cycle is controlled from a remote or automated control center, establish fail safe procedures to avoid automatic start up while servicing equipment in the circuit.

On equipment that includes heat shields, make certain the shields are properly installed prior to starting the cleaning cycle (see Paragraph 4.8 and 9.3).

2.9 Cleaning Paraflows used with refrigerants

Refrigerants have high vapour pressures at moderate temperatures. Temperatures used in clean in place procedures will produce pressures exceeding the Paraflow design pressure

1. Any CIP system must have a fool proof method to avoid cleaning with refrigerant in the exchanger.
2. Any cleaning procedure must avoid temperatures causing the refrigerant to vapourize if refrigerant or residual refrigerant is present.
3. The refrigerant must be removed before cleaning and the refrigerant passages protected with relief devices in case of failure of isolation valves.

2.10 Cleaning chemicals in refrigerant Paraflows

In order to resist low temperatures and compressor lubricants elastomers used in refrigeration heat exchangers have a lower resistance to chemical attack . The time temperature relationship for various cleaning agents used with refrigeration gaskets (Paraprene, Low temp nitrile etc) is as follows..

Chemical	concentration maximum %	maximum temperature °C	duration maximum hours
caustic soda	1	60	2
nitric acid	0.5	60	2
phosphoric acid	5	60	2
sulphamic acid	0.25	60	1
hydrogen peroxide	1	40	1

Lowprene is a special blend of low temperature chloroprene and must not be subjected to any CIP above 40°C.

Never exceed 60°C with caustic soda (sodium hydroxide) when Paraprene gaskets are fitted.

Sulphamic gaskets solution must be freshly prepared to avoid oxidation to sulphuric acid.

3.0 CONSTRUCTION

3.1 Frame

A typical Paraflow Plate Heat Exchanger is shown in **Figure 1**. **Figure 2** is an exploded view showing the individual components. The main components include a stationary cover (head), Item 1, an end support, Item 2, connected by a top carrying bar, Item 3, and bottom guide rail, Item 4. These components are bolted together to form a rigid frame that supports the thin metal heat transfer plates, Item 5, and moveable cover (or follower), Item 6. Each plate is separated and sealed by a gasket. The plates are compressed between the head and follower by means of tie bars, Item 7 on either side of the exchanger. Liquids are introduced to the heat exchanger through connections located in the head, follower or intermediate connector grids, when supplied (as shown in Figure 3 on page 10).

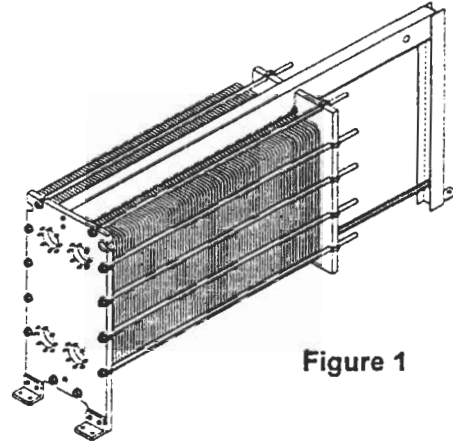

Figure 1

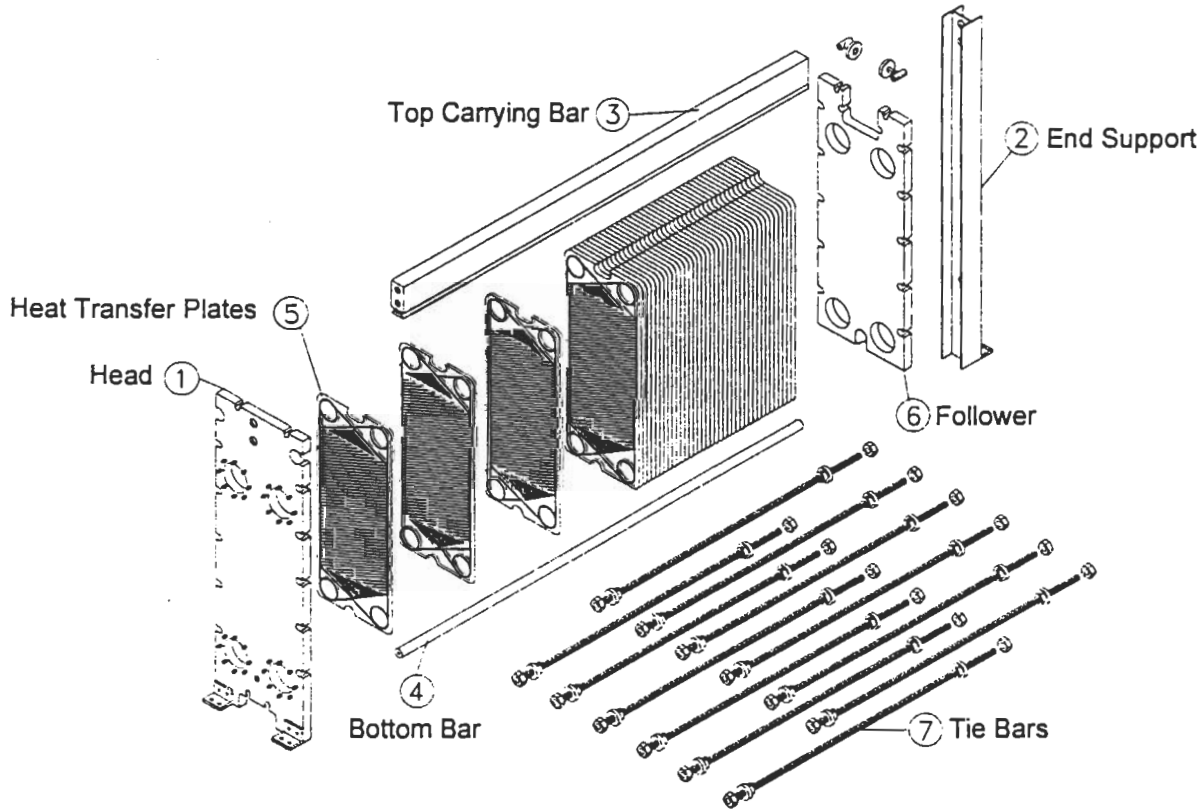

Figure 2

Paraflow Plate Heat Exchanger Instruction Manual

When Paraflow Plate Heat Exchangers are opened for service, the follower moves back along the top bar to allow full access to each individual plate. Divider plates and intermediate connector grids also move freely on the top carrying bar to provide easy access to individual plates.

Paraflow frames used in industrial duties are fabricated in carbon steel and are finished in a heavy duty chemical resistant paint. Industrial frame connections may be studded with various lining materials or nozzles. The nozzles are fabricated in carbon steel, stainless steel or alternate metals. Connection types may be lap-joint, weld neck or specialty flanges. Sanitary tube connections may also be supplied on carbon steel frames. The connection materials and types may be mixed on an individual frame.

Frames used for sanitary duties are usually fabricated in solid stainless steel or carbon steel that is entirely clad with stainless steel. The finish is either a #4 polish or glass bead blast depending on the model. Standard connections are sanitary tube fittings at all locations. Industrial fittings may be supplied when required.

Divider plates may be used to divide a heat exchanger into separate operating sections. Divider plates have no connections but may allow flow from one section to the next.

Intermediate connector grids as shown in **Figure 3** may be used to divide a heat exchanger into separate sections to accommodate multiple duties within a single frame. Connector grids may have up to two connections at any corner.

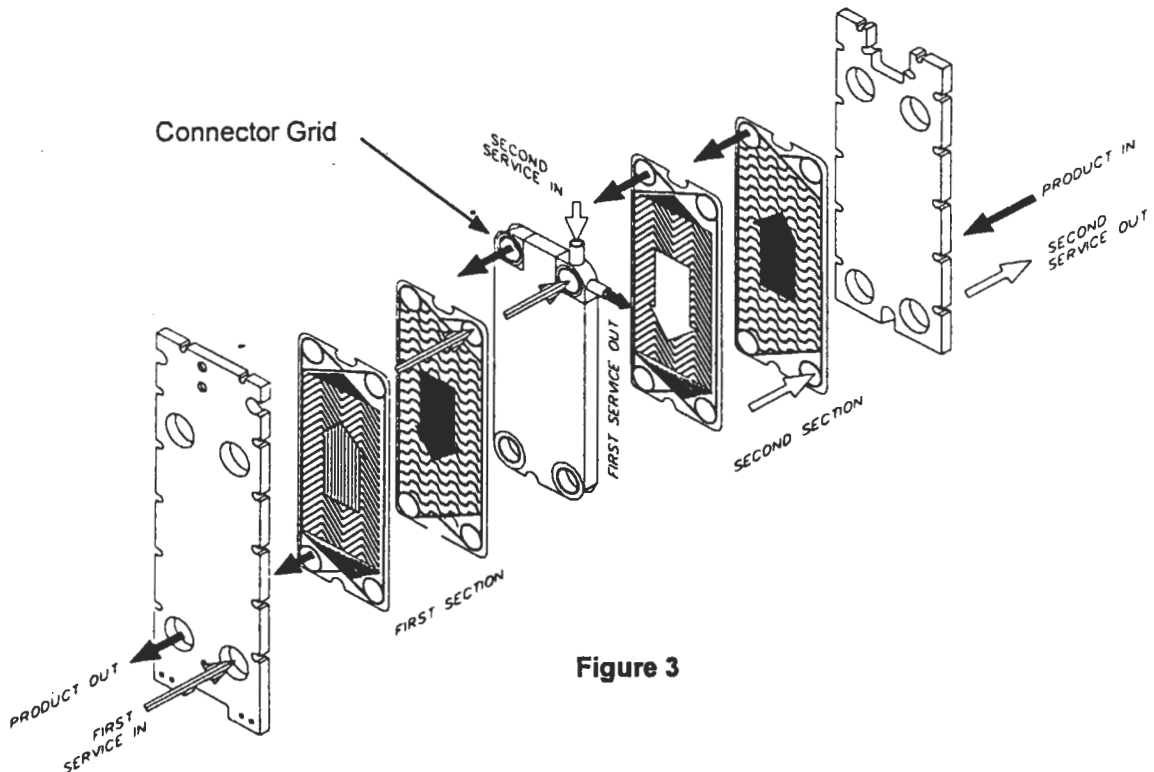

Figure 3

3.2 Plates

APV heat exchanger plates come in over 60 different sizes and 34 different corrugation patterns. This allows the heat exchanger to be matched closely to a specific duty. The corrugations cause turbulence in the liquids as they flow in a thin stream in the passage between each plate (Figure 4). The plates have ports in each corner that, when stacked in a plate pack, form a manifold for even fluid distribution to the individual plate passages (Figure 5). The ports are gasketed so only two ports on each plate allow flow across the plate (flow ports). The other two ports are through ports and do not allow the liquid flowing in them across the plate. This flow pattern is alternated from plate to plate to form right hand plates and left hand plates.



Figure 4

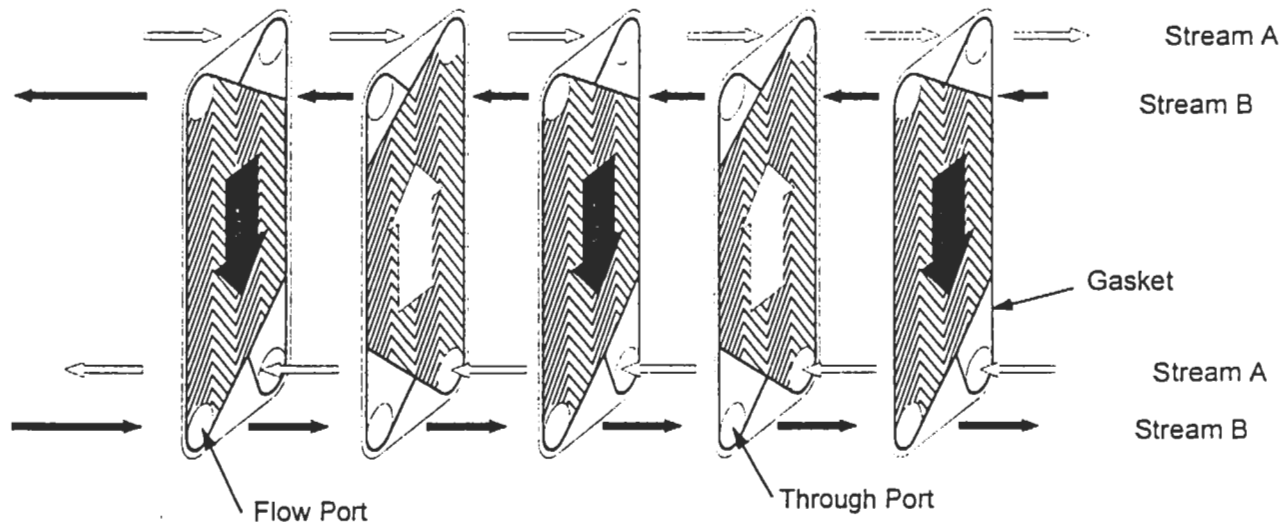
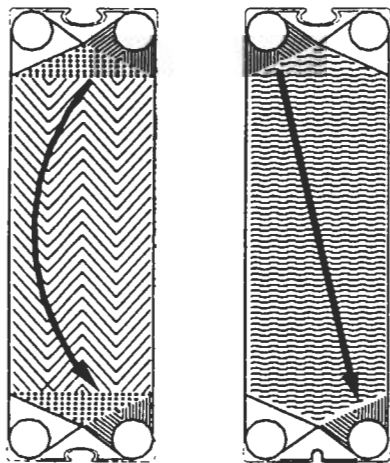

Figure 5

Plate Construction

All plates are designated as either diagonal flow or vertical flow (Figure 6) based on their flow pattern. Plates are pressed in thicknesses between 0.4 - 1.2 mm (0.016 and 0.047 inches) in a variety of materials (see Plate Materials below). The plate corrugation pattern alternates from plate to plate to provide support at the points of contact. One type of corrugation pattern looks like a washboard. It provides a wide gap between plates with contact points about every 1 to 3 square inch of heat transfer surface area.



Vertical Flow

Diagonal Flow

Figure 6

Another design is the chevron pattern of relatively shallow corrugations with support provided at peak/peak contact. Alternate plates are arranged so that corrugations cross to provide contact points for every 0.2 to 1 square inch of surface. This greater density of contact points in the chevron pattern allows a higher differential operating pressure for a given plate thickness than the washboard pattern.

Mixing Plates

To obtain optimum thermal and pressure drop performance while using a minimum number of heat exchanger plates, plates of two or more corrugation angles may be mixed within the same frame. This is available for many APV Paraflow Plate Heat Exchanger models.

Mixing plate angles results in flow passages that differ significantly in their flow characteristics. This allows the Paraflow design to be fine tuned in a single or even multiple pass arrangement to closely match to the thermal and pressure drop requirements of the application.

Plate Material

Paraflow plates may be pressed from 304 or 316 stainless steel, Avesta 254SMO or 254SLX, Nickel 200, Hastelloy B-2, C-276 or G-3, Incoloy 825, Inconel 625, Monel 400, Titanium, Titanium-Palladium or other specialty alloys as required to provide suitable corrosion resistance to the liquids being handled.

Duo-Safety Plate

The APV Duo-Safety heat exchanger plate is a double wall plate manufactured from two loose plates pressed together at the same time to form a pair. Each APV Duo-Safety plate pair is equipped with a non-glue Paraclip gasket, which seals and holds the pair together. The two plates can be made of different materials.

The space between the two plates of the APV Duo-Safety plate pair serves as a safety zone in case of through-plate leaks from corrosion or wear. Should this occur, the liquids will not be mixed, but will be discharged between the two walls into the atmosphere. This provides a high level of certainty that liquids will not be cross contaminated. The APV Duo-Safety plate pair also can be dismantled for cleaning between the two plate walls.

Paraweld Plate

The APV Paraweld plate is a right and left hand plate laser welded together to form a plate pair. This welded plate is particularly suited for use with refrigerants such as ammonia and Freon, or aggressive liquids that would otherwise attack the gaskets in a conventional heat exchanger plate.

The laser weld is done in a twin path for added security. When the welded pairs are installed in a frame, each pair is separated by elastomeric seals.

3.3 Gaskets

The seal between the plates is achieved by a single gasket around the perimeter of the plate and a double gasket around the two through ports. This double gasket separates the port from the heat transfer area with a double barrier. The space between the double gasket is vented to atmosphere to prevent cross contamination. (Figure 7).

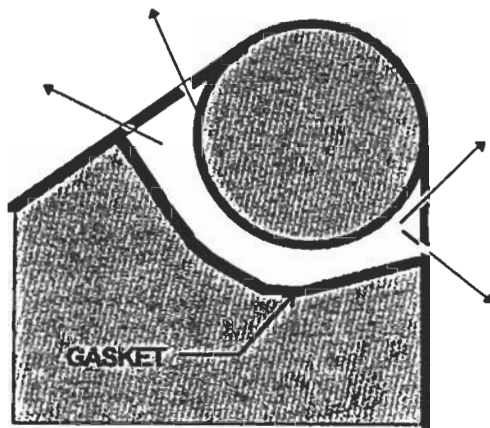

Figure 7

Interlocking Gaskets

APV Paraflow Plate Heat Exchanger plates have interlocking gaskets with upstanding lugs and scallops evenly spaced around the outside edges. These scallops ensure that there are no unsupported portions of the gaskets and, in combination with the patented form of the pressed groove, provide mechanical plate-to-plate support for the sealing systems. The upstanding lugs (Figure 8) maintain plate alignment in the Paraflow during plate pack closure and operation. The groove form provides 100% peripheral support of the gasket, leaving none of the material exposed to the outside. In addition, the gasket exposure to the process liquid is minimized by the full depth plate gasket groove.

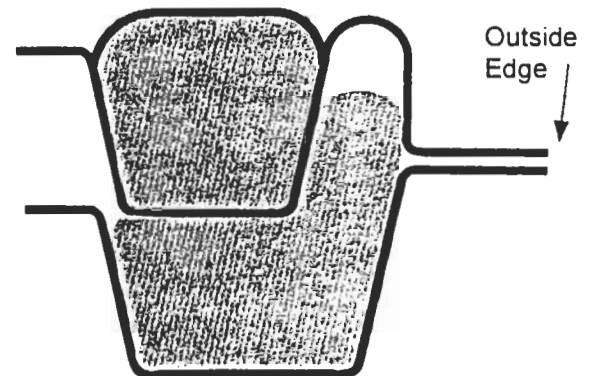

Figure 8

Gasket Materials

As detailed in Figure 9, various gasket materials are available as standard which provide chemical and temperature resistance coupled with excellent sealing properties. Other gasket materials are available for special applications. Gasket material selection must take into consideration the chemical composition of the fluids involved as well as the operating conditions.

Materials	Application
Paracil	General Purpose material for aqueous and fatty duties
EPDM	High temperature general purpose material for chemical and steam applications
Paraflor	Mineral oils, acids, steam and hot water at high temperatures
Paradur	Organic solvents, chemicals and sulfuric acid
Paraprene (Neoprene)	Refrigeration duties with ammonia and freon.

Figure 9

Gasket Attachment

APV Paraflow Plate Heat Exchanger gaskets are attached to individual plates by one of two methods, glued or clip in. The glued in gaskets are attached by a thermoplastic adhesive which is heat cured for maximum strength.

The clip in gaskets (Paraclip) are attached to the plates by small nubs around the perimeter of the gasket which snap into matching holes.

3.4 Intermediate Connector Grids

These intermediate connector grids divide the plate heat exchanger into separate sections that may operate independently. The connector grids are equipped with removable connector bosses (Figure 10) that provide connections for the liquids handled.

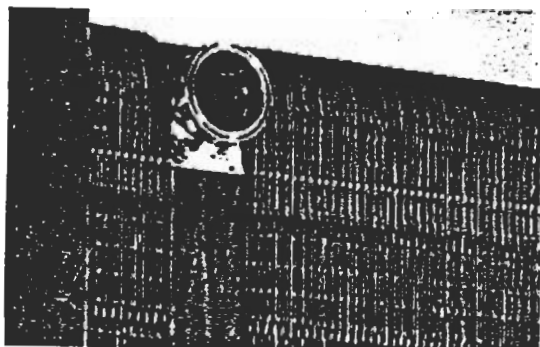

Figure 10

The connector grid bosses form the connecting link between sections of the plate heat exchanger and provide connections to and from these sections. On some models, two connections can be provided in the same connector grid boss with connections to the adjoining sections.

3.5 General Arrangement Drawing

A General Arrangement Drawing is supplied with each APV Paraflow Plate Heat Exchanger. This drawing provides detailed information concerning design specifications, operating conditions, dimensions, connections, plates and gaskets, plate arrangement diagram and key, bill of material and special notes.

Design Specifications

The data list on the design specifications provides the key mechanical information used to design the plate heat exchanger. This includes the design code, maximum allowable working pressure and temperature, maximum and minimum plate dimensions, heat transfer area, frame size, maximum plate capacity, weights and volume.

Operating Conditions

This table on the drawing contains the duty or operating conditions for which the heat exchanger was designed. It specifies each fluid, the flow rates, the temperatures and the pressure drops.

Connection Schedule

The connection schedule identifies the size, material and type of each connection supplied.

Plate and Gasket List

Each general arrangement drawing contains a summary of all the plates and gaskets used for the plate arrangement. This summary includes plate types, angles and material, and also gasket type, material and attachment (glued or clip in).

3.6 Plate Arrangement Diagram

Configuration of the Diagram

The plate heat exchanger is designed to perform a duty (or duties) by arranging the number and type of plates required in a specific sequence. This arrangement is represented schematically by the plate diagram shown on the general arrangement drawing. The schematic represents the fluid flows by heavy lines with arrows and the plates by thin vertical lines. Plate ports that block flow (not open) are represented by small black rectangles.

Each connection on the plate diagram is identified and labeled. The connections are also identified on the dimensioned view or the isometric view of the plate heat exchanger and the Connection Schedule.

Along the top of this diagram is a listing of each plate required, showing the hand of each plate (Right or Left), the direction the gaskets face (Head or Follower) and the punch code (blanking designation). The punch code indicates which ports are open and allow flow. Additional codes may be listed indicating plates with drains (D) and vents (V) or plates with end gaskets (K). Other symbols may be used to indicate special support pads or gaskets. The general arrangement drawing includes a key which illustrates the punch codes. The punch codes are also illustrated on the following pages in Figure 11 for vertical flow plates and Figure 12 for diagonal flow plates.

VERTICAL PLATE PUNCH CODES

LEFT HAND FLOW PLATES:

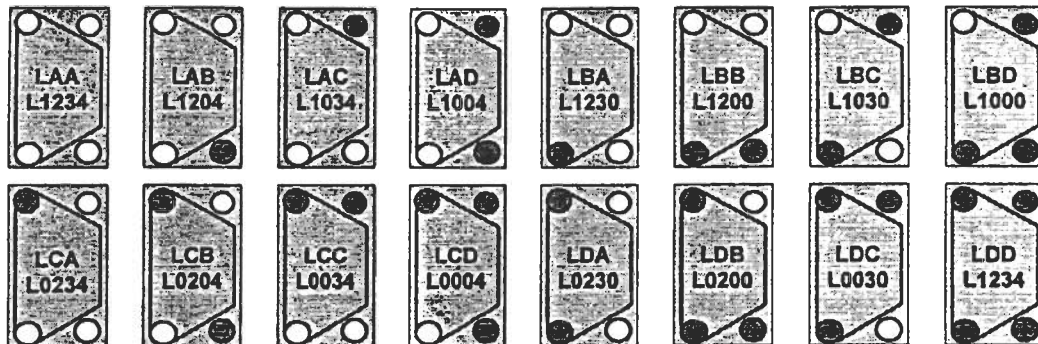

LEFT HAND END PLATES:

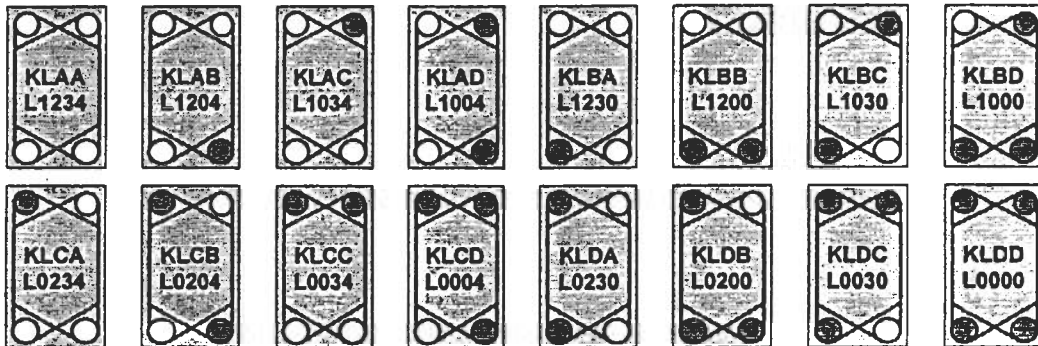

RIGHT HAND FLOW PLATES:

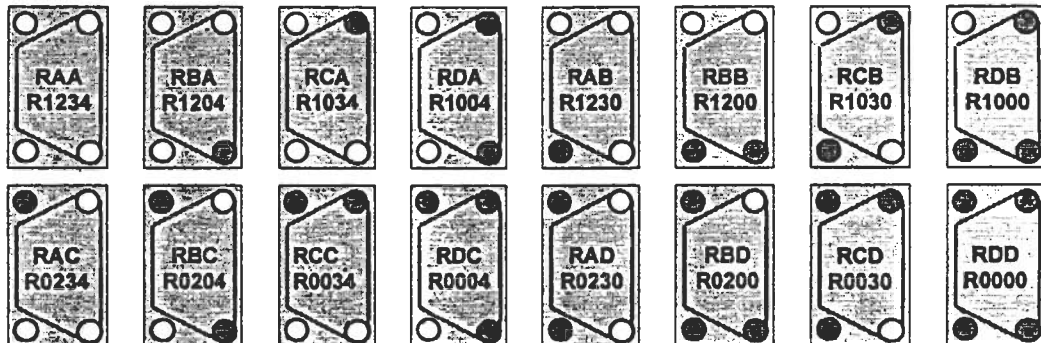

RIGHT HAND END PLATES:

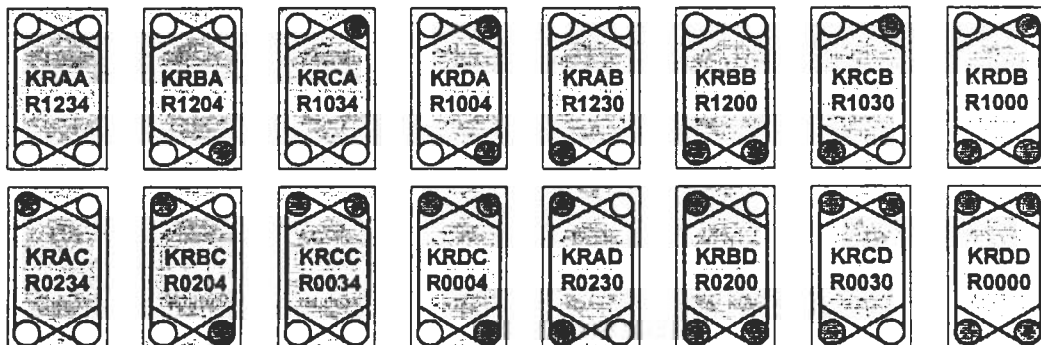

*PLATE VIEWED FROM GASKETED SIDE.

Blanked(Hole)

Unblanked(No Hole)

DIAGONAL PLATE PUNCH CODES

LEFT HAND FLOW PLATES:

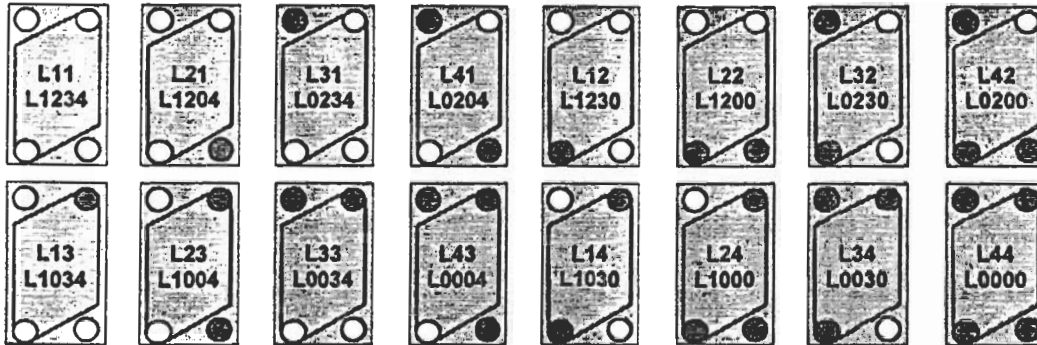

RIGHT HAND END PLATES:

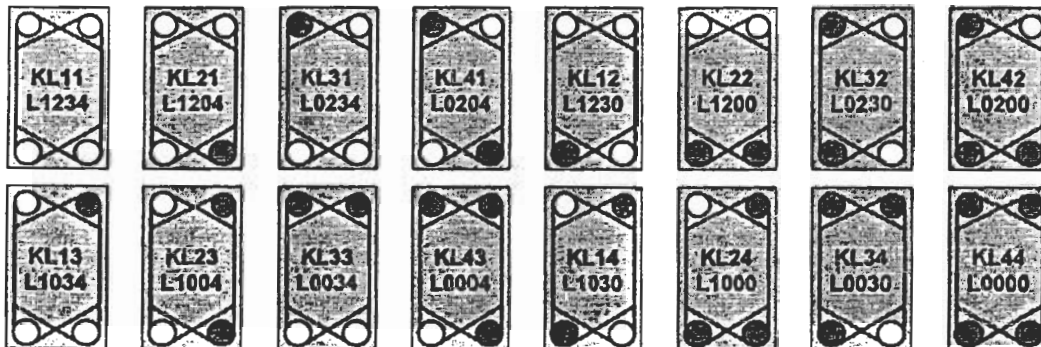

RIGHT HAND FLOW PLATES:

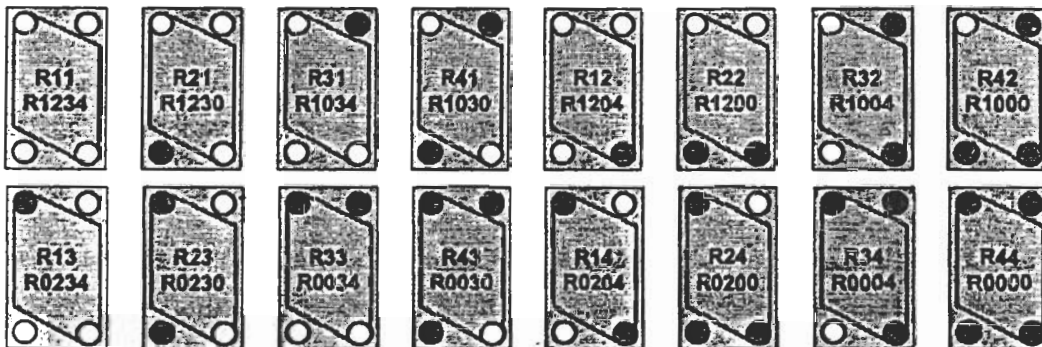

LEFT HAND END PLATES:

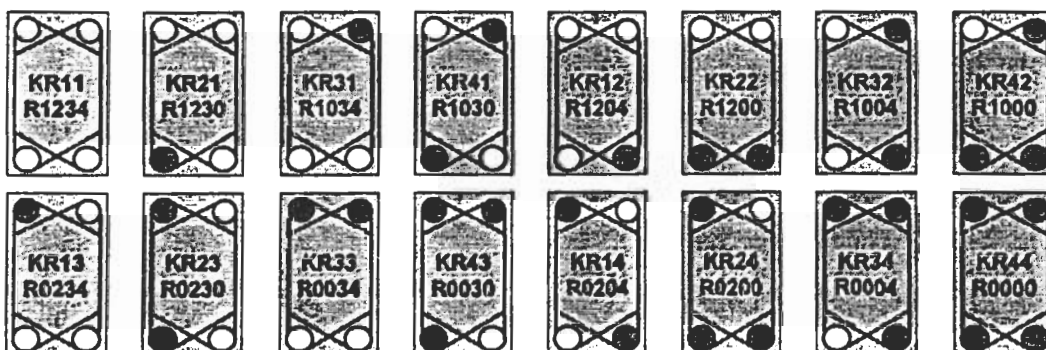

*PLATE VIEWED FROM GASKET SIDE.

 Blanked(Hole)

 Unblanked(No hole)

Examples

Figure 13 shows a typical single pass arrangement using diagonal flow plates with all the connections on the head.

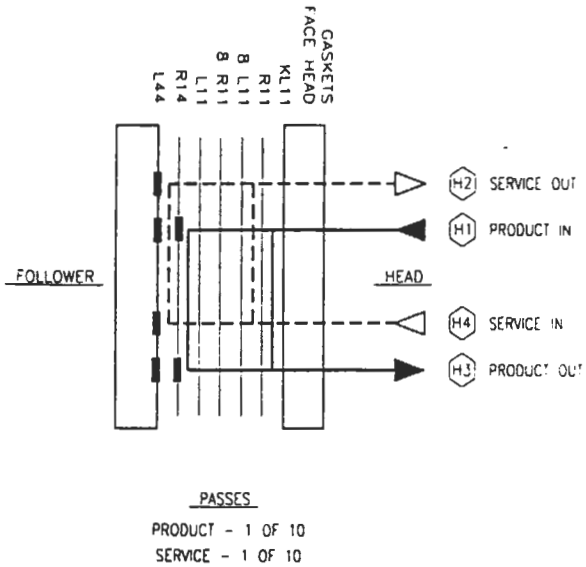

Note: Plates must be arranged alternately right and left. For simplification only, whole blocks of identical left or right hand plates are shown on the plate arrangement drawing with the total number of each given.

Figure 13

Figure 14 shows a typical three pass arrangement using diagonal flow plates with two connections on the head and two on the follower.

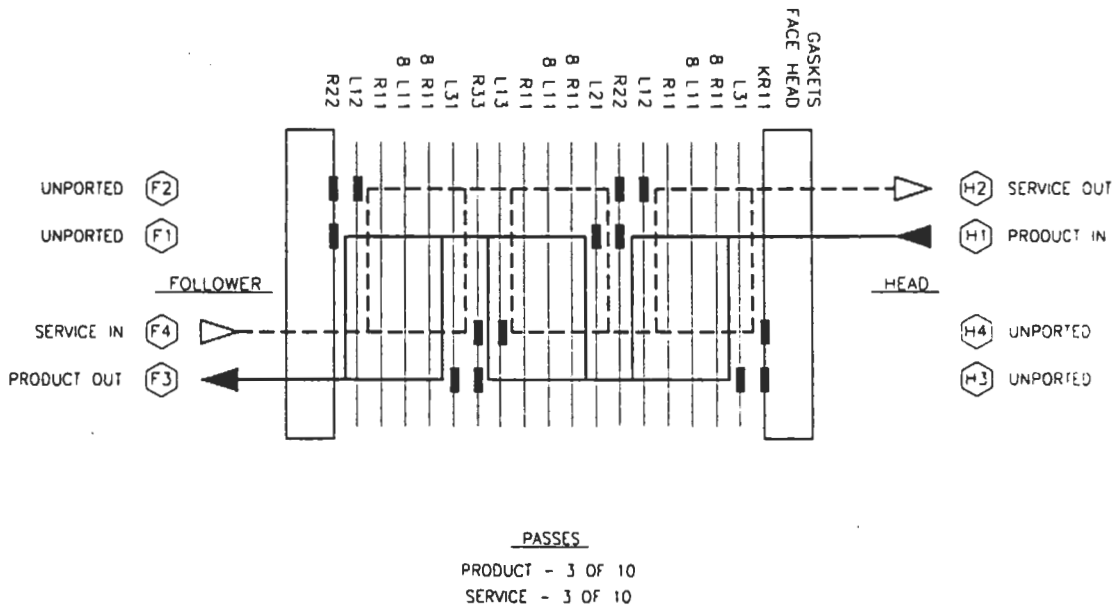

Figure 14

4.0 INSTALLATION

4.1 Location

The heat exchanger should be installed in an area with adequate clearance around the unit to install or remove plates and perform maintenance.

The unit should also be located with consideration for the required piping connections. Product and service lines should be designed to minimize pressure drops and be adequately supported to minimize the loads on the heat exchanger.

4.2 Foundations

The foundation pad for the heat exchanger should be level and sized properly for the outline of the frame. It must also be of adequate strength to support the full operating weight of the unit. The overall dimensions and operating weight are listed on the general arrangement drawing.

4.3 Space Requirements

On at least one side of the plate heat exchanger there must be sufficient clearance to remove a plate from the top bar. Also, there must be adequate room to tighten or remove the tie bars and inspect the plate heat exchanger (Figure 15). The follower must be free to move along the full length of the top bar as shown in (Figure 16). The general arrangement drawing provides overall dimensions and plate removal distance.

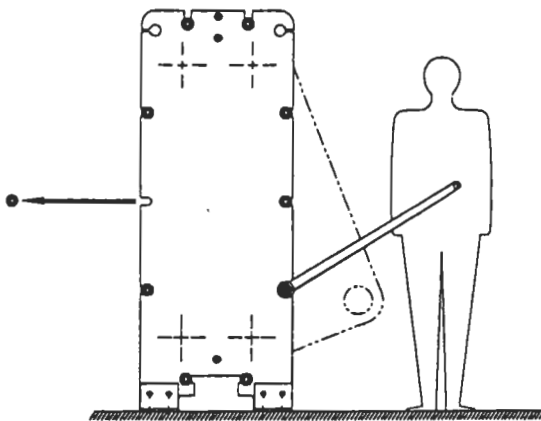

Figure 15

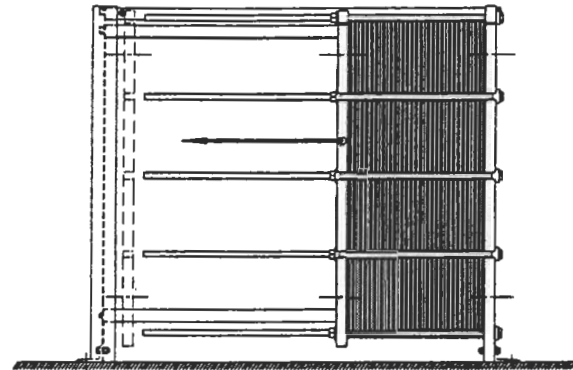

Figure 16

4.4 Connections and Piping

The plate heat exchanger must be connected in accordance with the arrangement shown on the general arrangement drawing provided with the heat exchanger.

Pipe lines to the follower and connector grid(s) must be located to allow the unit to be easily opened for inspection and maintenance. These lines must also be flexible to allow for small variations in the tightening dimensions and possible thermal expansion.

4.5 Pressure Pulsation and Vibration

Piston pumps, gear pumps, valves etc. must not be able to transfer pressure pulsations or vibrations to the plate heat exchanger as this may cause fatigue fracture in the plates. The use of pressure dampers in the pipeline is recommended to minimize this effect.

4.6 Pressure / Temperature Ratings

The pressure and temperature ratings for a specific heat exchanger are listed on the general arrangement drawing provided with the unit. These ratings must not be exceeded at any time during startup or operation.

Over pressure protection must be provided if it is possible the system may develop a higher pressure than the maximum allowable working pressure of the heat exchanger.

Warning:

Do not exceed the maximum operating pressure or temperature listed on the General Arrangement Drawing or damage to the heat exchanger will result.

4.7 Hydraulic Shock

The plate heat exchanger will be damaged by any hydraulic shock that occurs during start up or operating changes. To avoid damage, throttling valves and soft pump starts are recommended.

4.8 Heat Shields

A heat shield may be provided for new or existing heat exchangers. They are recommended whenever corrosive liquids or high temperatures are present. See Section 9.0 Accessories for more information.

4.9 Short Term Storage

All heat exchangers and components must be stored in a cool environment away from sunlight. They must also be covered loosely by a tarp or plastic sheet that allows air circulation and provides protection from water, debris and sunlight. This procedure is suitable when the storage period is less than six months.

4.10 Long Term Storage

Long term storage of APV Plate Heat Exchangers requires following Procedure SP5002 to avoid damage or deterioration. This procedure should be used when a heat exchanger will not be placed in service within six months after shipment from the factory. This procedure should also be used when an installed heat exchanger will be out of service for more than six months. Contact the Customer Service Department listed in Section 8.0 of this manual for copies of the procedure and assistance.

Caution:

A heat exchanger which has been in storage for more than five (5) years should be inspected by an APV representative prior to preparing it for operation.

5.0 ASSEMBLY

5.1 Handling

APV Paraflow Plate Heat Exchangers are shipped fully assembled and skid mounted, or when required, they are shipped unassembled in boxes. In either case, proper handling practices must be followed. The weight of an assembled heat exchanger is listed on the general arrangement drawing. Weights of components are listed on the shipping box. The skids and boxes are designed to be moved by standard lift trucks of proper capacity.

5.2 Lifting

All APV heat exchangers are provided with lifting holes, lugs or eyebolts to simplify lifting. The general arrangement drawing shows their size and location. When lifting an assembled heat exchanger frame, ensure that the lifting point is approximately above the center of the plate pack. A spreader beam is recommended for large or long frames.

Warning:

All lifting equipment must have the proper capacity and be in good condition. Personnel must follow safe rigging practices at all times.

5.3 Assembling the Frame

Caution:

All components must be properly supported during all phases of assembly.

The following steps are recommended to safely assemble an APV heat exchanger. These instructions refer to the components illustrated in Figure 2 in Section 3.0.

When assembling a heat exchanger frame, start by erecting and securing the head. Fasten the bottom guide bar to the head by the bolts supplied and block it up. Bolt the end support to the bottom guide bar with the bolts supplied. See Figure 17. Note that shorter bolts are used at the end support.

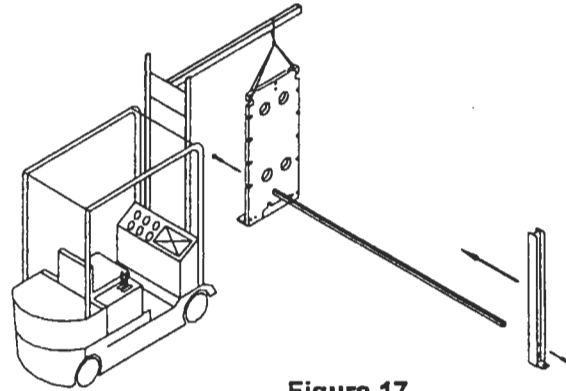

Figure 17

Position the follower in the frame next to the head and brace it securely. See Figure 18.

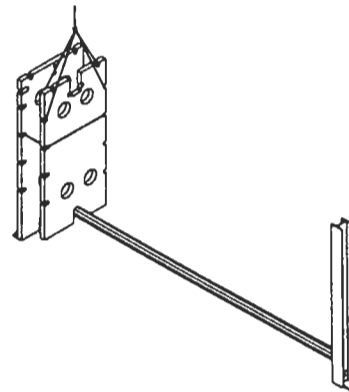

Figure 18

Position the top carrying bar between the head and end support and using the bolts provided, fasten it securely. See **Figure 19**.

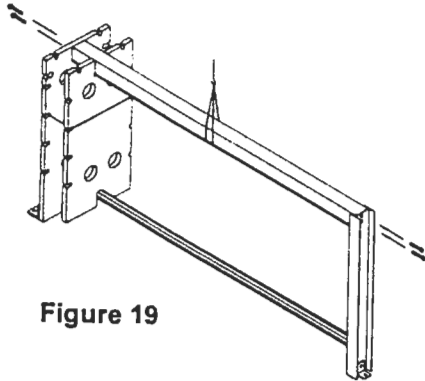

Figure 19

Lift the follower into place and install the roller and axle assembly. See **Figure 20**. Roll the follower back to the end support to allow plate installation.

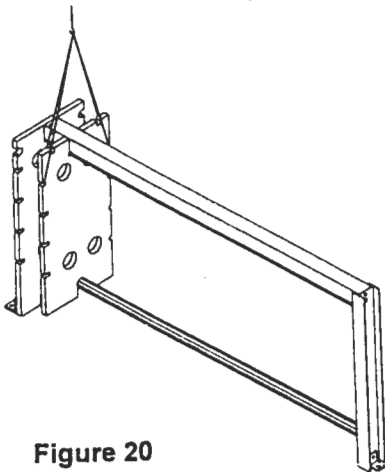

Figure 20

5.4 Installation of Plates

Wipe the top carrying strip clean between the head and the end support and apply a petroleum based grease to allow the plates to slide freely.

Install all the plates of the type and quantity specified on the plate arrangement drawing, starting at the head end of the frame. Check to make sure all plates are oriented properly, that gaskets are properly seated in their grooves, and there is no debris anywhere on the plates or gaskets. Clean the sealing surface with a lint free cloth. Push each plate firmly against the previous one. Use special care with plates having Paraclip gaskets (gaskets clipped to the plates) to avoid dislodging them. See **Figure 21**.

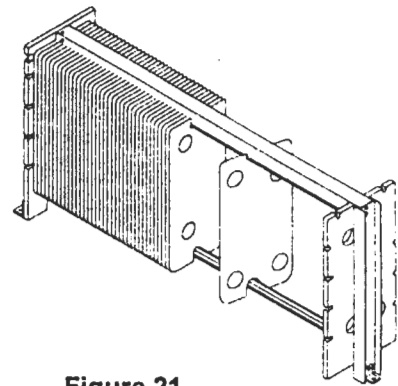

Figure 21

Note: The plate arrangement on the general arrangement drawing indicates if the gasket side of the plate faces the head or follower.

CAUTION:

During installation, always alternate left and right hand plates. For simplification only, whole blocks of identical left or right hand plates are shown on the plate arrangement drawing. The total number of each is given.

5.5 Installation of the Tie Bars

When all plates have been correctly installed, roll the follower up to the end of the plate pack. Install the tie bars into the frame holes or key hole slots as specified by the tightening instructions below.

Clean the tie bar threads and liberally apply an anti-seize compound along the area where the nuts will travel during tightening. Also apply the compound to both sides of the plain washer under the tie bar nut. APV recommends **Never-Seez® Regular Grade Lubricant** for carbon steel tie bars and **Never Seez® Black Moly Lubricant** for stainless steel tie bars. Do not use standard grease as it may result in galling. **Figure 22** shows an assembled frame with tie bars installed.

CAUTION:

Never-Seez® Regular Grade is not suitable for stainless steel tie bars.

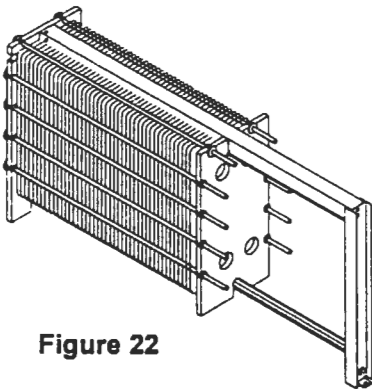

Figure 22

5.6 Closing Tie Bar Frames

The intent of these instructions is to provide a method to evenly and safely tighten a Paraflow Plate Heat Exchanger with tie bars. Proper tightening is essential for satisfactory operation and maximum gasket life. These instructions should be followed closely for both initial assembly and whenever the exchanger is closed after service.

1. Confirm that plates are all installed correctly to the general arrangement drawing. Check the quantity and orientation (alternating left and right). Move the follower toward the fixed head as far as it can go. Install four tie bars as shown in **Figure 23**.

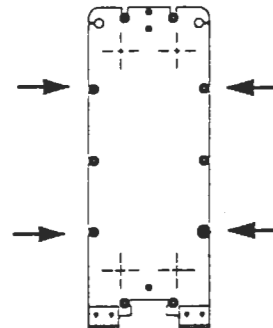

Figure 23

2. Starting with the top tie bar pair and alternating with the bottom, tighten the tie bars evenly about 1/2" to 1" at a time until the plate dimension (thickness of the plate pack) measured at the installed tie bars is equal and the follower is parallel to the head. This measurement should be about 10% over the final plate dimension specified on the Paraflow plate arrangement drawing. Throughout this step, keep the dimension from one side to the other at each pair of tie bars within 1/4". Also, always tighten the top pair of tie bars first to keep the plates from riding up.

WARNING:

Never tighten a Paraflow which is under pressure from any source.

Never tighten a Paraflow with piping connected to the follower or connector grids.

3. Install the rest of the tie bars on the sides of the heat exchanger between the ports (if applicable) and tighten them evenly until the plate dimension is the same at all installed tie bars.

4. Starting with the top pair of tie bars, continue tightening equally about 1/4" at a time until the platage dimension measures about 5% above the final dimension.
5. Install the remaining tie bars (if applicable) above the top ports and below the bottom ports of the frame. Starting with the top pair and working down, tighten each pair 1/8" at a time. After each tightening cycle of 1/8", return to the top set of bars and repeat the procedure.

NOTE: On large heat exchangers using 2", 42 mm or 48 mm diameter tie bars, it may only be possible to achieve 1/16" movement during the final stages of tightening.

6. Tighten the exchanger to the maximum platage dimension specified on the plate arrangement drawing. The dimension must be the same at all tie bars. See **Figure 24**

WARNING:

Refer to your plate arrangement drawing for the proper tightening plate dimension.

NOTE: Due to o-ring type gasket seal, the final closed dimension is determined by dimension, not tie bar torque.

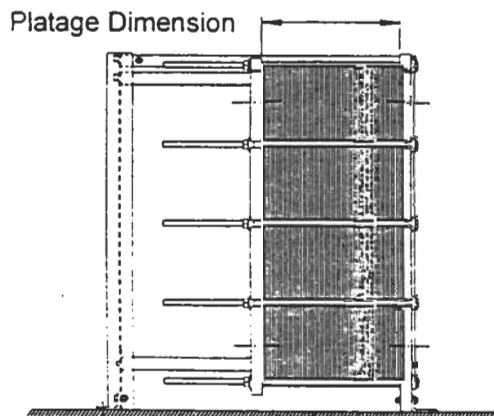

Figure 24

Manufacturing tolerances of the plate may result in the actual minimum platage dimension varying. Refer to your plate arrangement drawing for actual minimum and maximum dimensions.

7. Pressure test the heat exchanger for leaks by using **potable water** at the desired pressure but do not exceed the pressure specified on the drawing. The test may be done on each side separately or on both sides at once. Make sure all air is vented from the heat exchanger before performing the pressure test.
8. If leaks occur, the heat exchanger may be further tightened and retested. It is suggested that this be done in steps of approximately 0.001" per plate until the leak stops or the minimum dimension specified on your general arrangement drawing is reached.
9. If the leaks continue, mark them carefully and open the exchanger in accordance with Paragraph 5.7. Inspect the area of the leaks closely for damaged gaskets, plates, sealing surfaces or debris. Replace all suspect plates or gaskets, clean the sealing surface with a lint free cloth, and repeat steps 1 through 7.

5.7 Opening Tie Bar Frames

Tie bar frames may be opened safely by following steps 1 through 6 in Paragraph 5.6 in reverse order. The tie bars must be loosened in the same sequence and amount as described in each step.

WARNING:

Never open a Paraflow until the unit has been cooled below 100°F (38°C).

Never open a Paraflow which is under pressure from any source.

Never open a Paraflow with piping connected to the follower or connector grids.

6.0 STARTUP AND OPERATION

6.1 General

Prior to startup, make sure the unit is correctly assembled and the piping connected properly. Also, check that the plates have been compressed to the proper dimension specified on the general arrangement drawing. See Figure 24 and refer to Section 5.0.

Warning:

Proper assembly and tightening are required for safe startup and operation.

6.2 Startup

Caution:

All pipe lines must be inspected and flushed clean prior to operation. Strainers are recommended to prevent debris from installation from entering the unit.

Sudden surges and rapid changes in pressure or temperature must be avoided, as these may damage the plates and gaskets. Throttling valves, flow diversion valves and shut off valves must be operated slowly. Control flows with throttling valves downstream of the heat exchanger.

Caution

Do not allow the pressure to change more than 150 psig (10 bar) per minute or the temperature more than 20°F (11°C) per minute.

Improper startup will cause damage to the heat exchanger frame, plates or gaskets. Follow instructions closely.

Valves located on the outlet side of any liquid stream must be opened prior to startup to prevent dead heading the heat exchanger.

If steam or another condensable vapor is used as a heating media, it must be turned on after liquid has been introduced on the product side.

During initial startup, the exchanger may develop minor leaks. If these leaks do not stop when the unit has reached operating temperatures, refer to Paragraph 6.5 Troubleshooting.

Air in the heat exchanger will normally be carried out by the liquid flow. However, it is good practice at startup to vent air from the system at a high point in the piping. This will ensure the system is filled with liquid.

6.3 Operation

During operation, the same precautions against rapid changes of pressure or temperature during start-up must be observed. Once normal operating conditions are reached, temperature and pressure drops must be regularly checked. Increasing pressure drops and/or falling temperature may indicate reduced performance of the heat exchanger. This must be investigated to determine the cause. See Paragraph 6.5 Troubleshooting.

Warning:

Do not exceed the maximum operating pressure or temperature listed on the general arrangement drawing or damage to the heat exchanger will result.

6.4 Shut Down

The heat exchanger must be shut down slowly and allowed to cool naturally to room temperature. Inlet valves, if used, should be closed before outlet valves. If steam is used as a heating media, it must be shut off first. In cooling duties, the cooling liquid must be shut down first to avoid freezing of the product.

All liquids must be drained from the heat exchanger after shut down to prevent precipitation of products or scale buildup.

If the heat exchanger will be out of service for six months or longer, it must be properly prepared for storage. See APV Standard Procedure SP5002 for instructions. Contact the Customer Service Department listed in Section 8.0 of this manual for copies of the procedure and assistance.

6.5 Troubleshooting

APV plate heat exchangers are designed to provide trouble free service over the life of the unit. However, conditions or processes may change, resulting in reduced performance or even leakage. The following table provides some guidelines for diagnosing common problems and suggested solutions.

This table is intended as a general guide only. Assistance in specific cases may be obtained by calling your nearest Service Center listed in the front of this manual or the Customer Service Department listed in Section 8.0.

Troubleshooting Plate Heat Exchangers		
Problem	Possible Causes	Suggested Solutions
1. Reduced Heat Transfer	<ul style="list-style-type: none"> a. The inlet temperatures or flow rates do not correspond to the original design. b. Plate surfaces have become fouled on either the product or service side. c. Freeze up. 	<p>Correct temperatures or flow rates to design conditions.</p> <p>Open the heat exchanger and clean the plates or clean the plates in place by circulating a suitable cleaning agent -- see Section 7.0.</p> <p>Correct temperatures or flow rates to design conditions.</p>
2. Increased Pressure Drop or Reduced Flow Rate	<ul style="list-style-type: none"> a. Plate surfaces have become fouled on either the product or service side. b. Debris is blocking the flow channels. 	<p>See paragraph 1(b) above.</p> <p>Open the heat exchanger and clean the plates -- see Section 6.0. Screens or filters must be installed to prevent debris from entering the unit.</p>
3. Visible leakage	<ul style="list-style-type: none"> a. Operating pressure exceeds the rating of the heat exchanger. 	<p>Reduce the operating pressure to the rating of the heat exchanger. If the unit continues to leak after the pressure is reduced, the plates or gaskets are damaged and must be replaced. See Section 7.0.</p>

Troubleshooting Plate Heat Exchangers		
Problem	Possible Causes	Suggested Solutions
3. Visible leakage (continued)	b. The heat exchanger is not tightened adequately for the operating conditions.	Tighten the heat exchanger further in increments of .001 inch per plate, checking for leakage each time. Do not tighten below the minimum dimension shown on the general arrangement drawing -- See Paragraph 5.6. If leaks continue, see paragraph 3(c) below.
	c. Sealing surfaces of plates or gaskets may be damaged or dirty.	Open the heat exchanger and inspect the plates and gaskets. There must not be any cuts, cracks, debris or flat spots on the gaskets. Paracomp gaskets must not have any debris under the gasket. The plates must be clean and free of heavy scratches or dents on both sides. Replace the defective parts.
	d. Chemical attack of the gaskets.	Identify the source of chemical attack and correct either by eliminating the corrosive agent or changing the material of the gaskets.
4. Cross Contamination	a. Cracks in one or more plates. These may be caused by fatigue resulting from pressure fluctuations during operation. Dye penetrant testing may be required to identify cracks in the plates -- refer to Factory Service, Section 8.0 for assistance.	Open the heat exchanger and inspect the plates. Replace the defective parts. Identify the source of pressure fluctuations and correct.
	b. Holes in the plates caused by corrosion.	Identify the source of corrosion and correct either by eliminating the corrosive agent or changing the material of the plates.

6.6 Refrigeration Service

Paraflows in refrigeration service are never to be exposed to too high or too low a service level.

1. A high temperature will lead to loss of refrigerant through the customers vent devices.

The vent device must be sized to relieve the maximum flow of refrigerant that can be generated should a process upset occur.

Paraflows are extremely efficient heat transfer devices vapourization rates will be higher than seen in tubular exchangers. These rates can exceed 2500 Btu/h ft².°F.

2. A low temperature will also lead to a loss of refrigerant. Avoid allowing refrigerant liquids and gases to expand into evacuated sections of the exchanger. Low temperatures will freeze the gaskets and can take the machine below it's MDMT.

3. If the exchanger is evacuated to exclude air, slowly allow gas only to enter the exchanger until the system has reached atmospheric pressure and then charge the exchanger with liquid refrigerant.

4. The refrigeration system and the exchanger should contain sufficient refrigerant that the compressor does not draw a low temperature / vacuum condition at startup.

5. Never allow the process medium to freeze. Freezing causes expansion and can lead to process side leaks and gasket damage.

7.0 MAINTENANCE

7.1 Opening the Frame

WARNING:

Never open a Paraflow until the unit has been cooled below 100°F (38°C).

Never open a Paraflow which is under pressure from any source.

Never open a Paraflow with piping connected to the follower or connector grids.

Opening Tie Bar Frames

Drain all fluids from the heat exchanger and allow it to cool. Loosen the tie bars evenly in reverse order of steps 1 through 6 in Paragraph 5.6. Remove the tie bars and push the follower towards the end support (Figure 25). The plates may now be separated for cleaning and inspection.

WARNING :

In some instances the plates are supported only from the bottom. (DH frames etc.)

Great care should be used opening these Paraflows as the plates can fall back.

Partially release the the follower without removing the tie bars and nuts, loosen and make the plates lean towards the head.

Always anchor and secure the plates to the head with a temporary sling before drawing back the follower.

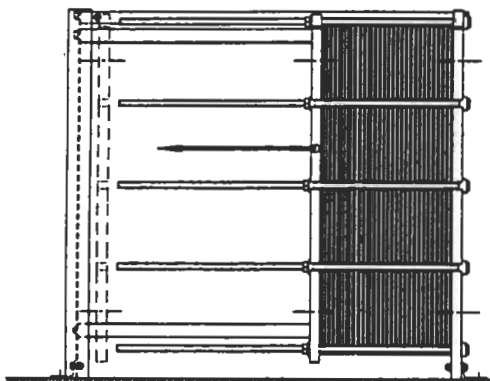

Figure 25

7.2 Inspection

Check the front and back of every plate for cleanliness and freedom from debris. Product build up and scale will reduce the performance of the heat exchanger and cleaning is required - See Paragraph 7.3.

Check each plate for cracks or holes. Some cracks may not be readily visible and will require dye penetrant inspection to locate them. Contact your nearest APV Service Center listed at the front of this manual.

Gaskets must be thoroughly checked for cuts, flattening, cracks, brittleness, breakage and proper fit of the gasket groove. The gasket groove in the plate must be free of distortion or kinks.

The entire gasket and sealing surfaces of the plates must be totally free of any debris since any foreign material will cause leakage and may damage the gasket. When installing clip in gaskets, careful inspection is required to be sure there is no debris or glue from previous gaskets under the installed gasket which will cause leakage.

7.3 Cleaning

APV offers factory cleaning, testing and regasketing services at Service Centers located around the country. A customer's plates are thoroughly cleaned, inspected both visually and with dye penetrant, and new Paraclip or glued in gaskets installed as required. Call Factory Service at 1 800 263 3958 for more information and pricing.

To maintain the performance and resistance to corrosion of the plate heat exchanger, it is essential that the plates be kept clean. Product build up and scale must be removed either manually or by CIP (Clean In Place) procedures outlined below.

Manual Cleaning

After a heat exchanger has been opened, individual plates can be removed for cleaning with a soft brush and a suitable detergent. In case of thick layers of scale or organic materials, the plates may be put in a bath of a suitable cleaning solution. Do not use a steel brush, metal scraper or similar tool which will damage the plate or gasket. A high pressure cleaner can be used with care. However, never clean with sand or other abrasives.

Clean In Place (CIP)

Cleaning in place is accomplished by circulating a suitable cleaning solution through the heat exchanger instead of opening it. This removes deposits or trapped product on the plates. CIP works best in the reverse direction of normal flow. Good results are also possible with same direction flow and higher velocities.

Great care must be taken to select proper cleaning solutions and cycles to avoid damaging the plates and gaskets. Due to the large variety of cleaning needs, each user is responsible for determining the best method for his situation. It is recommended that a reputable supplier of cleaning materials be consulted for assistance.

Caution

The heat exchanger must be thoroughly drained and rinsed immediately following CIP. Residue from CIP may cause corrosion if left in the heat exchanger.

7.4 Replacement of plates

Before replacing a plate in a heat exchanger, the new plate must be checked against the plate it is replacing. The new plate must be identical in every way.

The general arrangement drawing provided with the heat exchanger provides information on the material, port punching, gaskets and location of each plate in the heat exchanger.

Note: During the installation, **always alternate left and right hand plates**. For simplification only, whole blocks of identical left or right hand plates are shown on the plate arrangement drawing. The total number of each is given. Vertical flow plates may be changed from left hand to right or vice versa by turning the plate over.

7.5 Regasketing

Plate heat exchanger gaskets are attached to individual plates by one of two methods, glued or clip in. Glued in gaskets are attached by a thermoplastic adhesive which is heat cured for maximum strength.

The clip in gaskets (Paraclip) are attached to the plates by small nubs around the perimeter of the gasket which snap into matching holes.

Removal of old gaskets

To remove Paraclip clip in gaskets, the gasket may be carefully pulled from the plate. If the gasket is to be reused, pull slowly to avoid tearing off the clips or stretching the gasket.

To remove glued in gaskets, the bond between the plate and gasket is softened by using a propane torch to heat the plate from the nongasketed side directly behind the gasket. As the adhesive softens, use pliers to pull the gasket from the groove. Continue this process until the entire gasket has been removed.

Caution

Avoid overheating the metal. This will discolor and damage the plate.

To remove remaining traces of old adhesive, grease or dirt from gasket grooves, use a solvent such as Acetone or a commercial gasket removal product. Do not use abrasives to clean the gasket grooves.

Attachment of Glued in Gaskets

To attach new replacement gaskets, apply a thin even film of 3M formula EC-1099 adhesive to the plate gasket groove. The adhesive may be spread evenly with a small acid brush dipped in acetone. Allow the adhesive to dry until tacky, about 30 seconds. Press the gasket firmly in place, starting at one corner of the plate and continuing across and along the length of the plate. The entire gasket must be firmly in place with no twists or bumps.

As each plate is gasketed, it should be stacked neatly on a clean, flat surface in the order it will be installed. Take special care not to move the gaskets out of position. After all the plates are regasketed, they may be placed in the frame. The frame is tightened per Paragraph 5.6 to a platage dimension about 10% above the maximum compressed platage specified on the general arrangement drawing.

Heat treatment is essential to cure the adhesive and obtain maximum bond strength. This is done using steam or hot water to heat the plate pack. Attach a low pressure desuperheated steam line to an upper port and slowly raise the temperature of the plate pack to at least 220°F (105°C). Maintain the temperature for a minimum of three hours.

If steam is not available, hot water may be used with the same temperature and time requirements as steam.

After the required time, allow the heat exchanger to cool naturally to room temperature and complete the tightening to the required dimension per paragraph 5.6.

Attachment of Paraclip Gaskets

Non glued Paraclip gaskets are an alternative to glued in gaskets that greatly simplifies on site regasketing. The gaskets have a series of small nubs or projections molded into the underside of the gasket. These projections fit into corresponding slots located around the periphery of the plate and port areas, securing the gasket to the plate (Figure 26). When the plate heat exchanger is tightened, a complete and secure seal is assured.

To attach a Paraclip gasket, the gasket is laid out on the plate in its correct position. The projections are firmly pressed into the corresponding slots in the plates. After installing the gasket, the plate may be immediately installed in the frame in preparation for tightening.

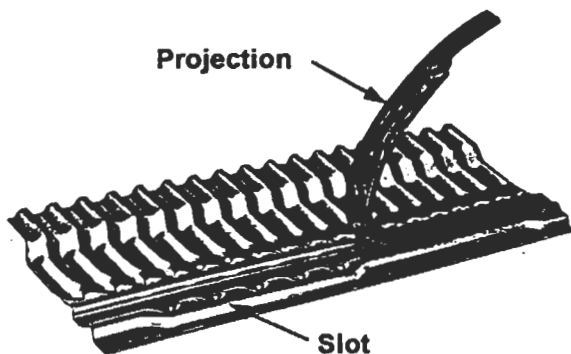

Figure 26

General Notes on Gaskets

1. Surface finish. Some gaskets are supplied with a surface pretreatment. This can either take the form of an etched surface (seen as a crazed or rough surface on the side adhesive is applied to) or a surface with a chemical coating. The bonding agent is intended to be left in place on the gasket and used together with the recommended adhesive to attain a bond between the metal and the gasket. **DO NOT REMOVE THIS SURFACE OR FINISH FROM THE GASKET.**

2. Fluoroelastomer and fluoro-EPDM gaskets. These gaskets are fixed to the plates with a mixture of adhesives designed to give a strong adhesion. The precise mixture of adhesives can be supplied by your local service centre.

8.0 PARTS AND SERVICE

8.1 Ordering Parts

Parts, plates and gaskets may be ordered from the following address. Please have the original order number , drawing number or nameplate details available when you call.

APV Canada Inc.
30, Whitmore Rd ,
Woodbridge ,
Ontario, L4L 7Z4

Tel: 905 850 1852

Parts may be ordered directly from APV
Canada by telefax on

Fax: 905 850 1863/5

APV Canada has other offices in Canada and
these can be accessed through the above .

8.2 Service

APV has service centres at various locations in
Canada. Service and factory personnel and
design engineers are available for site support
throughout Canada. Regasketing services are
available on site or at a service centre. Please
call the above facility for help.

8.3 Documentation

Copies of this manual, the General Arrangement
Drawing or other documents referenced by this manual
may be ordered from the Customer Service
Department listed in Paragraph 8.1.

9.0 ACCESSORIES

9.1 Manual Tightening Wrenches

Manual tightening wrenches are available for most APV Paraflow Plate Heat Exchangers to allow opening and closing a unit in the field. Ratchet type wrenches specifically designed for tie bars are available for medium to large exchangers. The T4, Junior, H17, SR1, TR1 and SR2 use box wrenches of the correct size. Power tightening equipment is required to tighten LR9, TR9, SR14, B Series and SR23 heat exchangers.

9.2 Power Tightening Equipment

Pneumatic Wrench

To facilitate the closing and tightening of large heat exchangers or units containing numerous plates, pneumatic tightening wrenches are available in two models, both as single or dual units. Figure 27 shows a single tightening unit being used to close a typical heat exchanger.

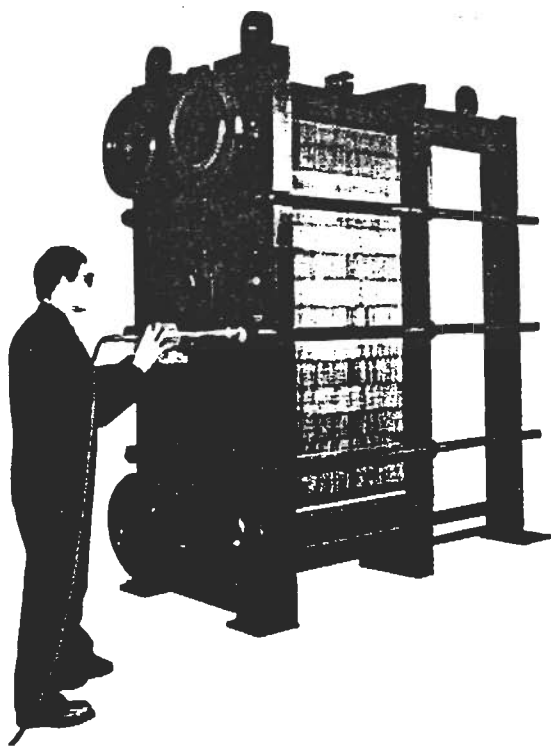

Figure 27

Figure 28 shows the pneumatic power tighteners recommended for specific tie bar tightening heat exchangers. Figure 29 gives a description of each tightener model.

Pneumatic Wrench Recommendations

MODEL	SINGLE PT-5	DUAL PT-5	SINGLE PT-7	DUAL PT-7
SR3	GOOD	BEST		
R4/LR4	GOOD	BEST		
R5	GOOD	BEST		
SR6 SERIES	GOOD	BEST		
R8	GOOD	BEST		
SR9	GOOD	BEST		
TR9/LR9 SERIES			GOOD	BEST
B SERIES			GOOD	BEST
SR14 SERIES			GOOD	BEST
SR23 SERIES			GOOD	BEST

Figure 28

The power tightener assemblies require clean lubricated air at a minimum of 90 psig at the filter-regulator inlet. Air consumption is 25 scfm full load or 40 scfm no load for each tightener.

Tightener Data

TIGHTENER MODEL	DRIVE	SPEEDS	WEIGHT EACH
PT-5	1"	1 FORWARD 1 REVERSE	60 LB. (27 Kg)
PT-7	1-1/2"	2 FORWARD 2 REVERSE	80 LB. (36 Kg)

Figure 29

9.3 Heat Shields

A heat shield may be supplied for new or existing plate heat exchangers. They are recommended whenever corrosive liquids or high temperatures present a safety hazard to personnel near the exchanger. These heat shields enclose the plate pack completely on the sides and top and are easily removed. The bottom is open to allow leak detection. **Figure 30** shows a typical installation.

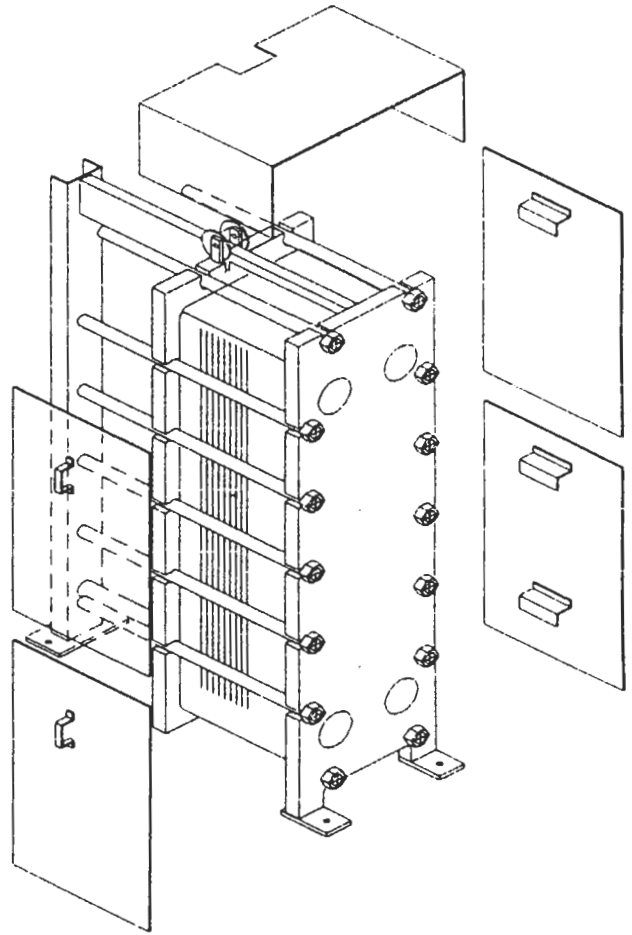

Figure 30

9.4 Hydraulic Rams

A newer approach to closing Paraflow heat exchangers is to use hydraulic rams. Using power tighteners makes the worker tighten tie bars individually or in pairs. With the use of hydraulic rams the whole pack is tightened together. Once fitted temporarily to the machine the manual effort is reduced and the tightening process can be completed by a single person.

For machines built prior to 1996 APV can supply a frame and power pack to close the exchanger.

More recent machines have notched sections included in the frame design allowing additional ram tie bars to be fitted. This avoids the stripping of thread problems that can occur when reusing tie bars.

Contact your service centre for ram rental or purchase.

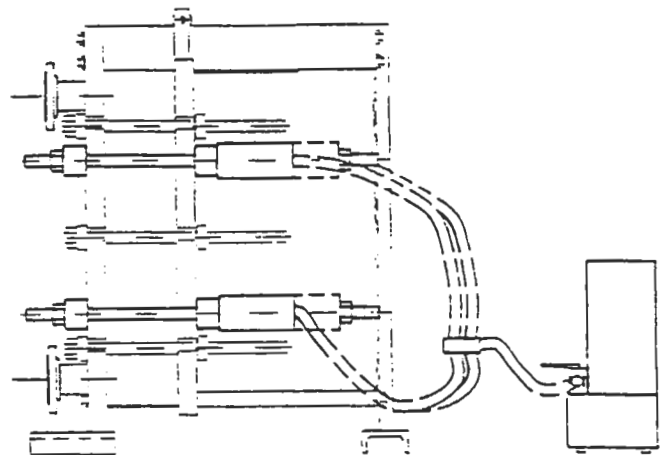

COMPRESSOR



APV Canada Inc.

30 Whitmore Road
Woodbridge, Ontario L4L 7Z4
Phone: 905 - 850 - 1852
Fax: 905 - 850 - 1863 / 1865

APPENDIX A

DRAWING

APPENDIX B
ELECTRIC DIAGRAM

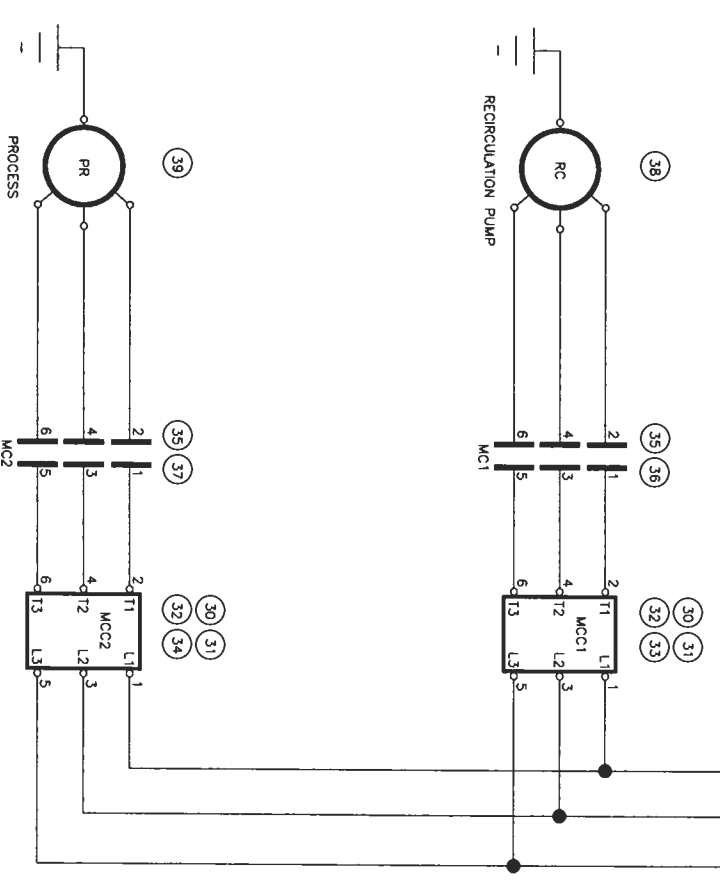
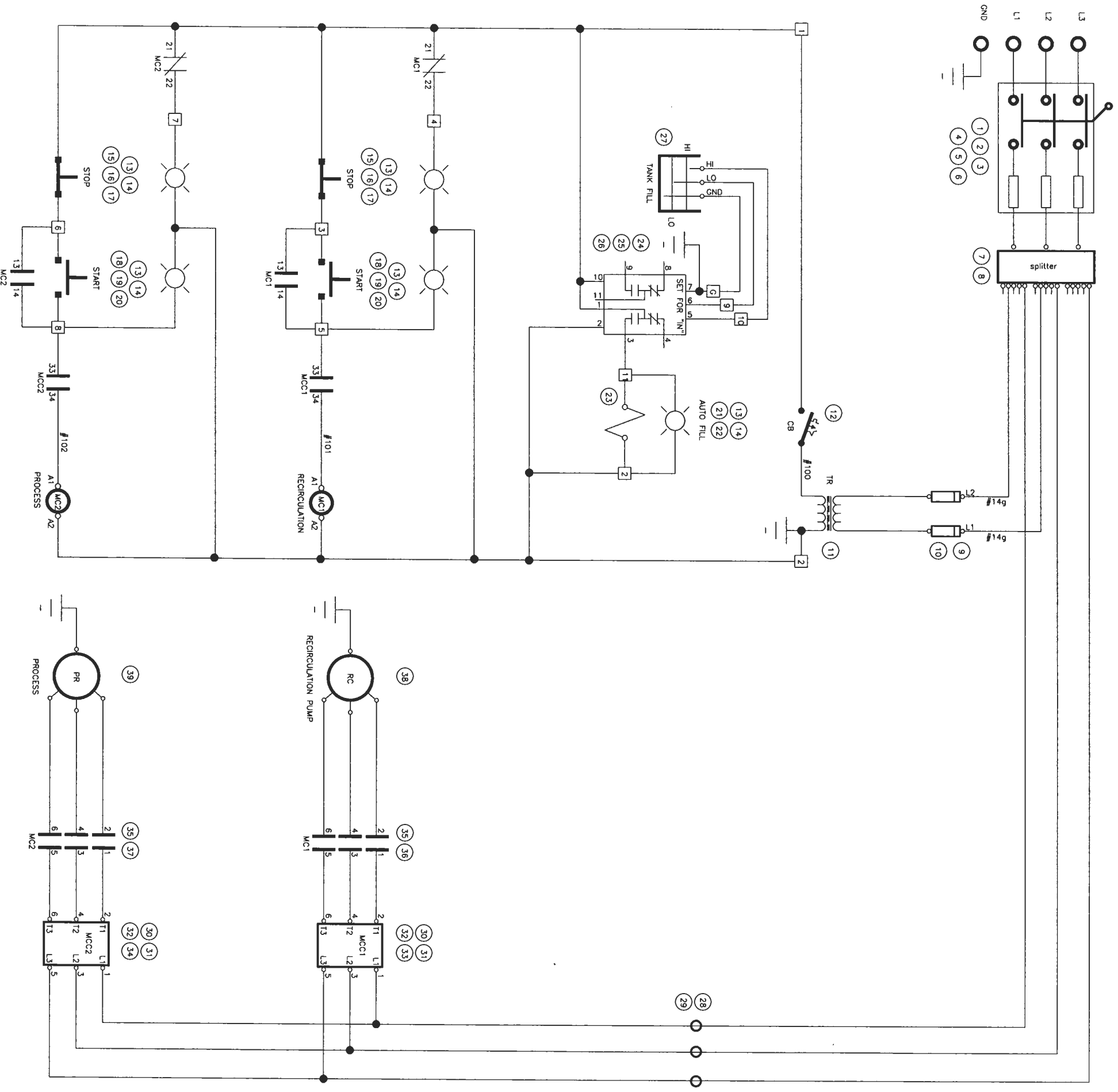

CB	=	CIRCUIT BREAKER
MC	=	MOTOR CONTACTOR
MCC	=	MOTOR CIRCUIT CONTROLLER
PR	=	PROCESS PUMP
RC	=	RECIRCULATION PUMP
SV	=	SOLENOID VALVE
TR	=	TRANSFORMER

Condir-Metaplast Ltd.

TITLE : SPRAY TANK
 ELECTRICAL :
 LEVEL CONTROL, 1x RECIRCULATION PUMP, 1x PROCESS PUMP

DWG# : 464-300-9010-00 DATE : 02/08/99

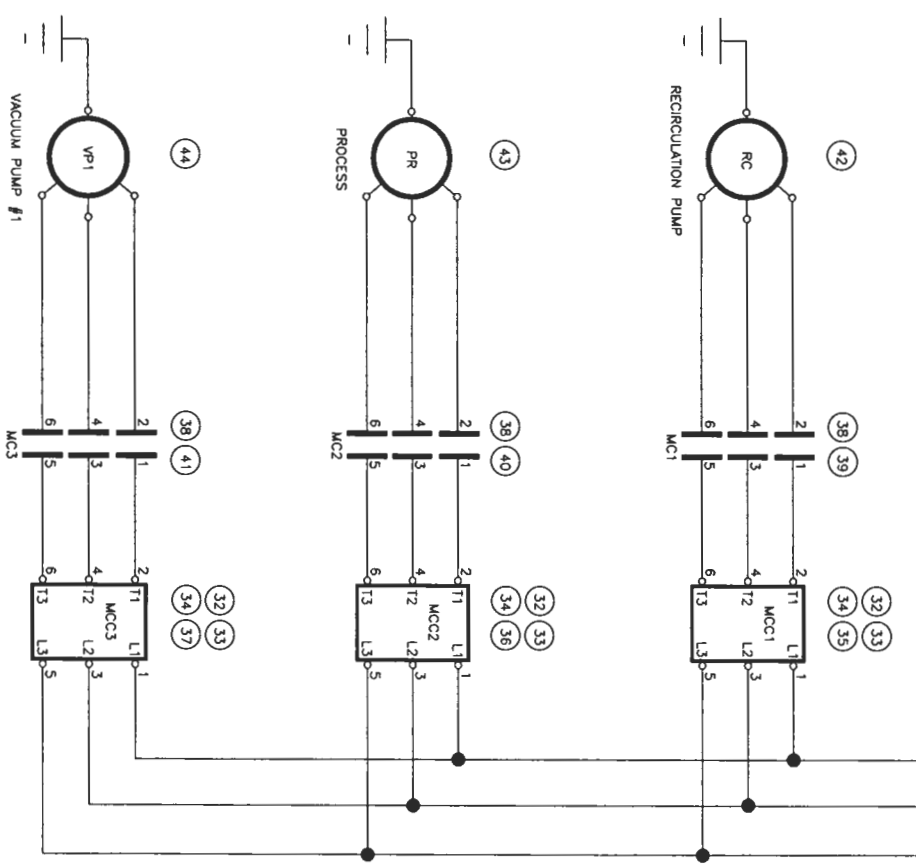
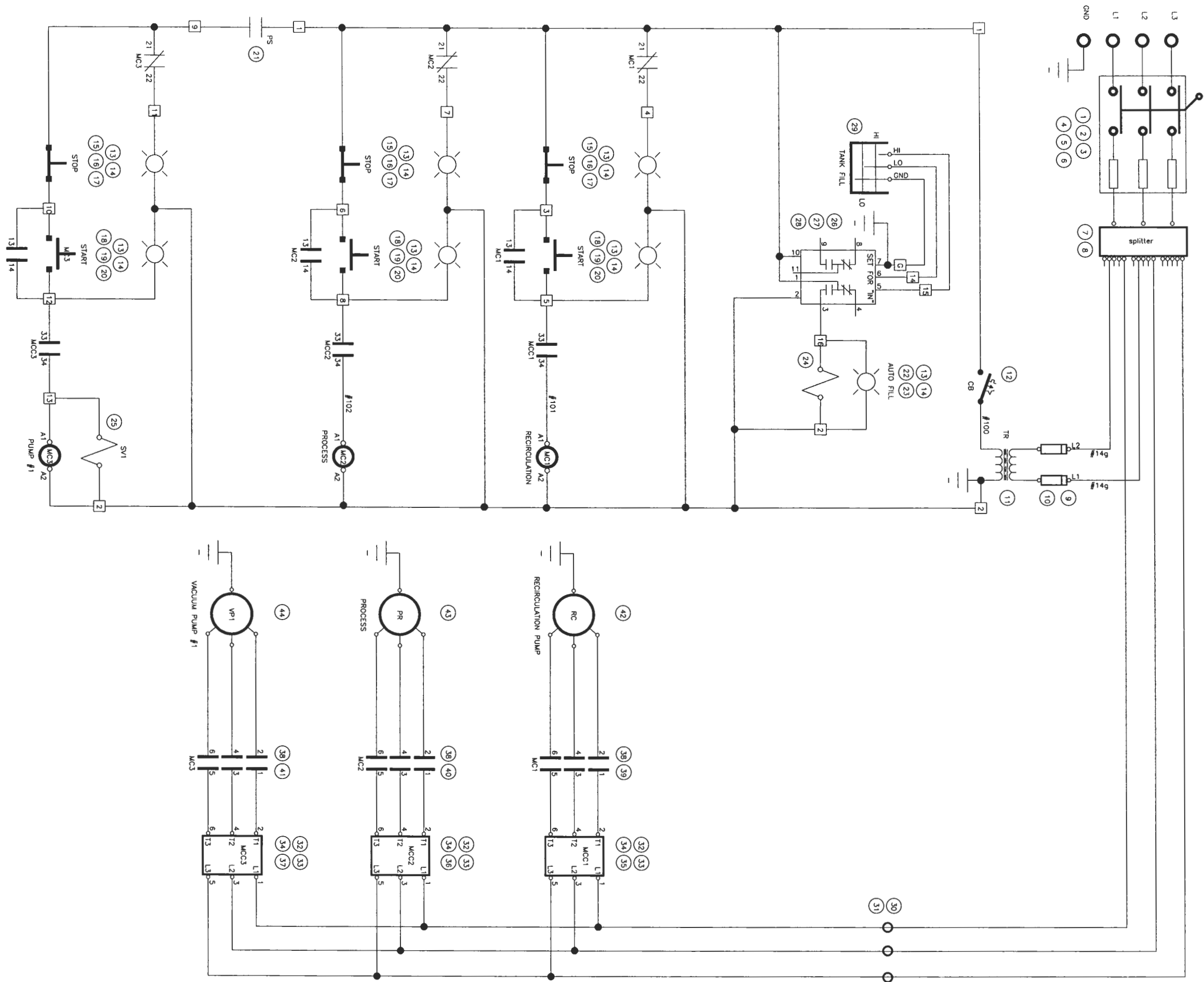

CB	=	CIRCUIT BREAKER
PS	=	PRESSURE SWITCH
MC	=	MOTOR CONTACTOR
MCC	=	MOTOR CIRCUIT CONTROLLER
PR	=	PROCESS PUMP
RC	=	RECIRCULATION PUMP
SV	=	SOLENOID VALVE
TR	=	TRANSFORMER
VP	=	VACUUM PUMP

Conair-Metoplast Ltd.	
TITLE : SPRAY TANK	
ELECTRICAL : PRESSURE SWITCH, SOLENOID ON VACUUM PUMP,	
1x VACUUM PUMP	
LEVEL CONTROL, 1x RECIRCULATION PUMP, 1x PROCESS PUMP	
DWG # : 464-300-9011-00	DATE : 02/08/99