

USER GUIDE
UGG010/0204

CLS Tangential Feed Granulators

Models CLS-810, CLS-814, CLS-819, and CLS-824

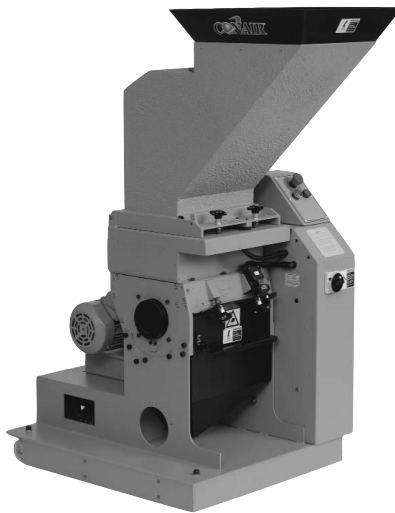

WARNING - Reliance on this Manual Could Result in Severe Bodily Injury or Death!

This manual is out-of-date and is provided only for its technical information, data and capacities. Portions of this manual detailing procedures or precautions in the operation, inspection, maintenance and repair of the product forming the subject matter of this manual may be inadequate, inaccurate, and/or incomplete and cannot be used, followed, or relied upon. Contact Conair at info@conairgroup.com or 1-800-654-6661 for more current information, warnings, and materials about more recent product manuals containing warnings, information, precautions, and procedures that may be more adequate than those contained in this out-of-date manual.

Please record your equipment's model and serial number(s) and the date you received it in the spaces provided.

It's a good idea to record the model and serial number(s) of your equipment and the date you received it in the User Guide. Our service department uses this information, along with the manual number, to provide help for the specific equipment you installed.

Please keep this User Guide and all manuals, engineering prints and parts lists together for documentation of your equipment.

Date:

Manual Number: UGG010/0204

Serial Number(s):

Model Number(s):

DISCLAIMER: The Conair Group, Inc., shall not be liable for errors contained in this User Guide or for incidental, consequential damages in connection with the furnishing, performance or use of this information. Conair makes no warranty of any kind with regard to this information, including, but not limited to the implied warranties of merchantability and fitness for a particular purpose.

Table of Contents

1. Introduction

- Purpose of the User Guide1-2
- How the Guide is Organized1-2
- Your Responsibilities as a User1-2
- ATTENTION: Read This so no One Gets Hurt1-3

2. Technical Specification

- Dimensions, Data, Sound Level2-2

3. Function Description

- General3-2
- Safety System3-4

4. Safety Instructions

- Safety Instructions4-2

5. Installation

- Pre-start checks 5-2
 - Two hours after first start 5-2
 - Electrical connection5-3
- Opening of hopper, screen box and granule bin5-4
- Closing the screen box, granule bin and hopper5-5

6. Operation and Daily Maintenance

Starting and Stopping	6-2
Inspection	6-3
Daily Inspection	6-3
Weekly Inspection	6-3
Monthly Inspection	6-3
Cleaning	6-4
Fault-finding, If the Granulator Does Not Start	6-6

7. Service

Changing the Knives	7-2
Removing the Knives	7-2
Installing the Knives	7-3
Transmission	
Inspection and Adjustment of Drive Belts	7-6
Lubrication	7-8
Cutter and Motor Pulleys	
Removal/Installing	7-9

8. Spare Parts List

Cutting Chamber.....	8-3
Staggered Rotor	8-4
Knives	8-5
Transmission	8-6
Screen	8-8
Screen Box	8-8
Outfeed, Granule Bin Manual	8-9
Outfeed, Vacuum Suction/Blower F-7/F-5	8-10
Hopper	8-11
Hopper Device	8-12
Safety	8-12
Sound Cabin	8-13
Enclosure/Body.....	8-14

9. Wiring Diagram

Wiring Diagram.....	9-2
Current sensing relay	9-3
Connection	9-4
Example	9-5

10. Accessories, Overview

Ordering Spare Parts	10-2
Third Fixed Knife, Removal, Installation	10-3

11. Transport and Storage

General	11-2
Unpacking and Checking	11-2
Lifting and Transport to Place of Use	11-2
Positioning in Place of Use	11-2
Storage	11-3
Long-Term Storage/Conservation	11-3

A. Customer Service

- We're Here to HelpA-1
- How to Contact Customer Service.....A-1
- Before You Call.....A-1
- Equipment GuaranteeA-2
- Performance Warranty A-2
- Warranty LimitationsA-2

Introduction

Purpose of the User Guide 1-2

How the Guide is Organized 1-2

Your Responsibilities as a User 1-2

ATTENTION:
 Read this so no one gets hurt 1-3







Purpose of the User Guide

This User Guide describes the Conair CLS Tangential Feed Granulators. It explains step-by-step how to install, operate, maintain and repair this equipment.

Before installing this product, please take a few moments to read the User Guide and review the diagrams and safety information in the instruction packet. You also should review manuals covering associated equipment in your system. This review won't take long, and it could save you valuable installation and operating time later.

How the Guide is Organized

Symbols have been used to help organize the User Guide and call your attention to important information regarding safe installation and operation.

-  Symbols within triangles warn of conditions that could be hazardous to users or could damage equipment. Read and take precautions before proceeding.
-  Numbers indicate tasks or steps to be performed by the user.
-  A diamond indicates the equipment's response to an action performed by the user.
-  An open box marks items in a checklist.
-  A circle marks items in a list.
-  Indicates a tip. A tip is used to provide you with a suggestion that will help you with the maintenance and operation of this equipment.
-  Indicates a note. A note is used to provide additional information about the steps you are following throughout this manual.

Your Responsibility as a User

You must be familiar with all safety procedures concerning installation, operation and maintenance of this equipment. Responsible safety procedures include:

- Thorough review of this User Guide, paying particular attention to hazard warnings, appendices and related diagrams.
- Thorough review of the equipment itself, with careful attention to voltage sources, intended use and warning labels.
- Thorough review of instruction manuals for associated equipment.
- Step-by-step adherence to instructions outlined in this User Guide.

ATTENTION:

Read This so no One Gets Hurt

We design equipment with the user's safety in mind. You can avoid the potential hazards identified on this machine by following the procedures outlined below and elsewhere in the User Guide.



WARNING: Improper installation, operation or servicing may result in equipment damage or personal injury.

This equipment should be installed, adjusted, and serviced by qualified technical personnel who are familiar with the construction, operation and potential hazards of this type of machine.

All wiring, disconnects and fuses should be installed by qualified electrical technicians in accordance with electrical codes in your region. Always maintain a safe ground. Do not operate the equipment at power levels other than what is specified on the the machine serial tag and data plate.



WARNING: Voltage hazard

This equipment is powered by three phase alternating current, as specified on the machine serial tag and data plate.

A properly sized conductive ground wire from the incoming power supply must be connected to the chassis ground terminal inside the electrical enclosure. Improper grounding can result in severe personal injury and erratic machine operation.

Always disconnect and lock out the incoming main power source before opening the electrical enclosure or performing non-standard operating procedures, such as routine maintenance. Only qualified personnel should perform troubleshooting procedures that require access to the electrical enclosure while power is on.

This manual applies to the CLS series of Conair granulators.

Model nos. CLS-810, CLS-814, CLS-819, and CLS-824 specify the size of the cutting chamber.



Read the Manual before installing and using the machine.



Be careful when the knives are accessible, they are sharp, and can cause personal injury!

- These Conair granulators are designed for granulating injection molded, blow molded and extruded plastic parts and scrap.
- The size and performance of the granulators are designed to suit the type of waste material.
- Approval must be obtained from Conair for granulating other products and materials for the warranty conditions to apply.
- The granulators are designed so that maintenance and cleaning can be done quickly and easily, both routine maintenance and changing of materials.
- All service must be done by trained service personnel.
- This Manual contains instruction for both handling and service.
- Chapter 7 contains instructions directed towards service personnel.
- Chapter 11 contains accessory equipment for the machine.
- Other Sections contain instructions for the operator.
- The granulators are delivered with an Instruction Manual and touch-up paint.
- Any modifications or conversions of the machines must be approved by Conair. This is to prevent injuries. The machine warranty and product assurance would otherwise be rendered void.
- Please address any queries to the local Conair representative or Conair customer service.

Technical Specifications

Specifications of a CLS Granulator 2-2

Meter Feed Granulators

CLS-810, CLS-814, CLS-819 and CLS-824

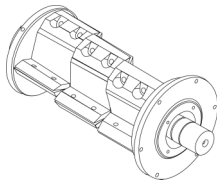
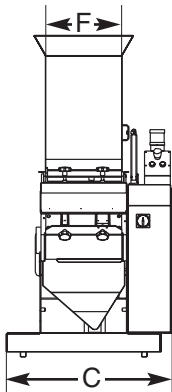
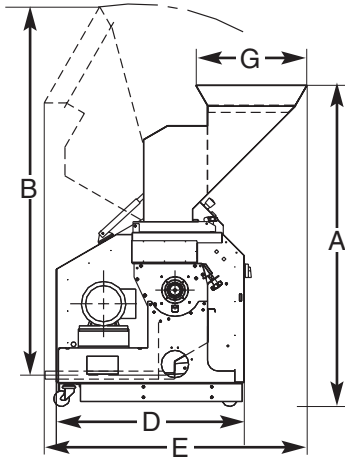

STANDARD STAGGERED ROTOR
with disposable, cassette knives

MODELS	CLS-810	CLS-814	CLS-819	CLS-824
Performance characteristics				
Throughput* (lb/hr {kg/hr})	150 {70}	200 {90}	250 {115}	300 {135}
Cutter chamber opening in. {mm}	8.7 x 9.5 {220 x 240}	8.7 x 14.2 {220 x 360}	8.7 x 18.9 {220 x 480}	8.7 x 23.6 {220 x 600}
Cutting circle in. {mm}	7.88 {200}	7.88 {200}	7.88 {200}	7.88 {200}
Rotor speed rpm	160	160	160	160
Standard motor power Hp	3	3	5	5
Drive type	gear reduced motor, belt drive			
Hopper type	single wall - top feed robotic hopper			
Vacuum discharge side	rear			
Screen mesh sizes	5/32, 3/16, 1/4, 5/16, 3/8, 1/2, in. {4, 5, 6, 8, 10, 12 mm}			
Rotor type	staggered rotor			
Knives				
Number of rotating knives	3 X 2	3 X 3	3 X 4	3 X 5
Number of bed knives	3	3	3	3
Dimensions inches {mm}				
A - Height - hopper closed	60.25 {1530}	60.25 {1530}	60.25 {1530}	60.25 {1530}
B - Height - hopper open	72.5 {1920}	72.5 {1920}	72.5 {1920}	72.5 {1920}
C - Width	26.5 {670}	31.25 {790}	36 {910}	40.5 {1030}
D - Base depth	35.5 {900}	35.5 {900}	35.5 {900}	35.5 {900}
E - Overall depth	50 {1270}	50 {1270}	50 {1270}	50 {1270}
F - Feed hopper opening - width	18.5 {470}	18.5 {470}	18.9 {480}	23.6 {600}
G - Feed hopper opening - depth	20.5 {530}	20.5 {530}	20.5 {530}	20.5 {530}
Weight lb {kg}				
Installed	684 {310}	705 {320}	895 {405}	1137 {515}
Shipping	772 {350}	794 {360}	1008 {460}	1281 {580}
Voltages Total amps based on standard motor				
208V/3 phase/60 Hz	11	11	20	20
230V/3 phase/60 Hz	10	10	18	18
460V/3 phase/60 Hz	5	5	9	9
575V/3 phase/60 Hz	4	4	7	7
Noise level†				
With no soundproofing	90-95 dbA			
With hopper soundproofing	85-90 dbA			
With hopper and base soundproofing	80-85 dbA			

SPECIFICATION NOTES:

* Throughput is based on a 3/8 inch {9.53 mm} screen. Throughput rates are provided as a capacity guideline only. Throughput will vary according to the selected screen size, the shape, thickness and properties of the material to be cut. Consult Conair for a material test or help determining the correct granulator model for your application.

† Noise level will vary according to material type being processed and the granulator configuration. These ranges are based on tests using SPI standards.

Specifications may change without notice. Check with a Conair representative for the most current information.

OPTIONS

- Discharge: manual, vacuum (standard), blower
- Hopper sound enclosure
- Base sound enclosure

	MOTOR OPTIONS ●=standard ○=optional			
	CLS-810	CLS-814	CLS-819	CLS-824
3 Hp	●	●	N/A	N/A
5 Hp	○	○	●	●

Function Description

General	3-2
Safety System	3-4

Function Description

General

The granulator is designed for grinding plastic waste to for recycling.

The plastic waste should be free from metal parts and contamination before granulating.

The granulator is controlled by start/stop controls on a control panel.

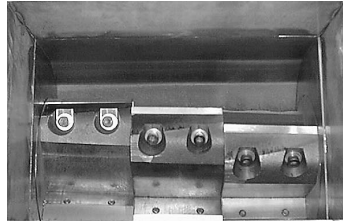

Standard cutter

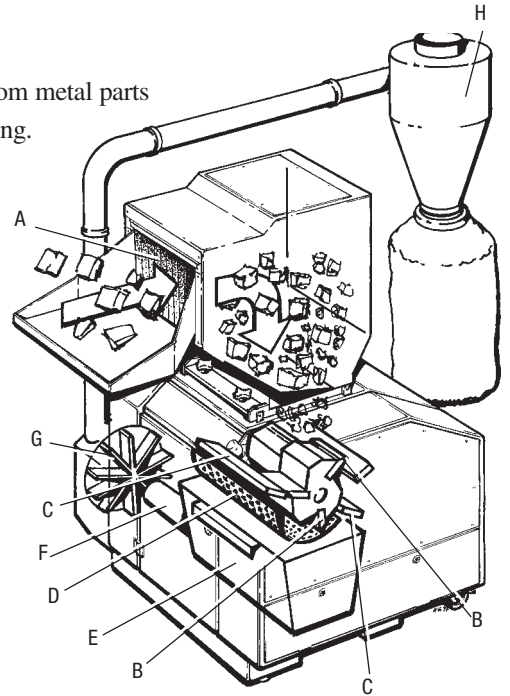

The plastics waste is feed into the hopper (A) and falls down into the cutter housing, where rotating knives (B) cut the plastics waste against fixed knives (C) to granulate.

A perforated screen (D) determines the size of the granulate. The screen is located in the lower section of the cutting chamber and can easily be changed to give the desired granulate size.

The granulate passes the screen and falls down through the outlet chute/granule bin (E) to the outlet pipe (F) for onwards transport.

Granulators with an extraction fan are equipped with an extraction blower (G) which sucks the granulate out to a cyclone (H) for separation of air. On granulator

models with a conveyor, the hopper is equipped with a conveyor belt. The conveyor can be equipped with a metal detector.

After this, the granulate is ready for re-use in the production machine, or to be transported to a container for later use.

The granulator is easy to clean, with a folding hopper and also good accessibility for maintenance. Knives on the staggered rotor are disposable and should be replaced when necessary.

Safety System

The granulator has a safety system to prevent access to dangerous components during operation.

The granulator has knives that rotate at high speed. The granulator is therefore equipped with a safety system to avoid personal injury.

The safety system must not be changed or modified under any circumstances.

If the safety system of the granulator is changed or modified, the machine can be dangerous to use, presenting a serious risk of personal injury.

All care and maintenance to the safety system of the granulator must be carried out by personnel with the necessary knowledge.

If the safety system of the granulator is modified in any way, Conair's responsibility under the Machinery Directive ceases to apply.

Only Conair spare parts must be used to replace safety components.

Emergency Stop

The granulator has an emergency stop on the control panel.

It can also be equipped with extra emergency stops.

The emergency stop is activated by pressing the button. Reset by turning the button in the direction of the arrow (counterclockwise).

Safety Switch

The granulator has safety switches of the position switch type with breaking key:

- If a secured position is changed or when a breaking key is undone, it will break the current and the granulator stops. This granulator has 2 safety switches:

1 at the hopper and 1 at the screen box

Check the wiring diagram (Section 9) to see how many safety switches the granulator is equipped with.

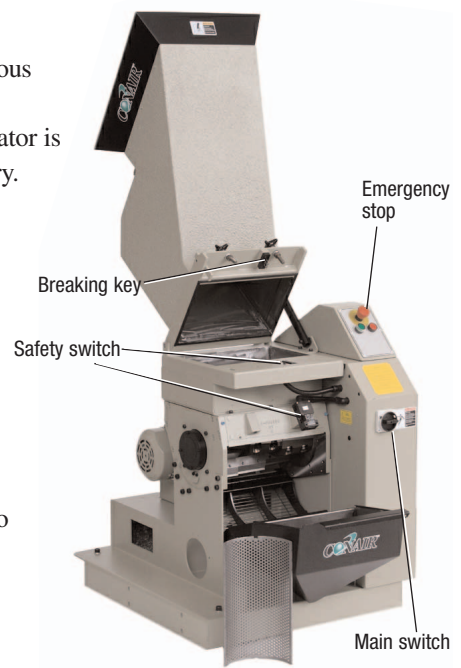



Star Knob

The star knob for the hopper and screen box is a very important component in the safety system of the granulator.

It should take such a long time for the knob/screw to be undone, that the cutter has stopped before the granulator can be opened.



-  **NOTE:** The length of the screw must never be changed.
-  **NOTE:** The screw can not be removed.
The screen is hardened and the knob is permanently attached.
 - To change a star knob, please contact Conair.
-  **NOTE:** If the star knob is modified in any way, Conair's responsibility under the Machinery Directive ceases to apply.

Before Starting:

The star knobs on the hopper and screen box must be fully tightened to stop.
The granulate bin should be installed and the door shut and locked.

Safety Instructions

Safety Instructions 4-2

Safety Instructions

Conair granulators are designed for granulating injection moulded, blow moulded and extruded plastic waste.

The specific technical data for this machine, concerning power and performance etc. is described in detail in Section 2.

The granulator is equipped with safety switches, which are described in Section 3.2.

Follow the instructions in this manual to avoid personal injury and damage to machine components.

Always follow these safety measures when handling the granulator.



- **Electrical installation must only be done by a competent electrician!**



- **Before the granulator is opened for servicing and maintenance. Always disconnect the power with both the main switch and the switch on the granulator.**



- **Never put any part of your body through the granulator openings, unless both the main switch and the switch on the granulator are in “Off” (0) position.**



- **Be careful with the knives, they are sharp and can cause personal injury.**



- **If the rotor must be turned manually – do this with great care!**



- **Observe care when opening or closing the hopper and screen-box, so as not to trap parts of the body.**



- **The granulator should not be able to start before the hopper and screen box are properly closed.**



- **Never remove protective guards or pipes adjacent to the outlet/granule bin.**



- **Granulators with belt conveyors! Observe care so that conveyor belts with dogs do not grip clothing, or arms and feet.**



- **During maintenance, pull out the plug on the distribution box.**



DANGER! High voltage!

This sign is on the door to the distribution box and the connection boxes.



DANGER! Cutting or pinch risk!

This sign is placed where there is a risk of being cut or pinched.



DANGER! Be careful!

This sign is located by all danger areas, where care and extra attention is required.

Installation

Pre-Start Checks	5-2
Two Hours After First Start	5-2
Electrical Connection	5-3
Opening of Hopper, Screen Box and Granule Bin	5-4
Closing the Screen Box, Granule Bin and Hopper	5-5

Installation

Read through the whole of Section 5 before installing the machine! All instructions must be followed in the given order to avoid injury or damage.



Be careful with the knives, they are sharp and can cause personal injury.



The granulator must only be connected to the mains by a competent electrician.

Pre-Start Checks

- The unpainted parts of the machine are protected with oil prior to delivery and transport Clean the granulator from rust protection agent before it is used.
- Check the knife clearance and tightening torque on the bolts for the knives. Refer to installation of knives in Section 7.

Two Hours After First Start

Check the knife clearance again and the tightening torque of the knife retention screws. Check the screws for both the fixed and rotating knives.



Electrical Connection

The granulator should be connected by a competent electrician.

- Connect the granulator to the main power supply. The wiring diagram indicates the fuse sizes, see Section 9.
- The granulator is delivered with electrical equipment connected for clock-wise phase rotation. Check with a phase sequence indicator and connect the granulator with clockwise phase rotation.

Check the direction of rotation of the granulator motor:

- Make sure that the main switch beneath the control panel is “On” (1).
- Check that the emergency stop is not activated.
- Check that the star knobs on the hopper and screen box locks are fully tightened to stop.
- Undo and remove the upper panel on the right hand side of the granulator.
- Press “Start”
- Check that the granulator motor rotates in the direction indicated by the arrow on the cutter pulley.
- Granulator with blower, – check that the direction of rotation of the blower corresponds with the arrow on the cover.



NOTE: The blower blows even if the direction of rotation is wrong.

- Granulator with conveyor belt, – check the direction of the conveyor belt.

If any direction of rotation should be incorrect:

- Press the stop button.
- Switch off the main switch.
- Switch two incoming phases.

Opening of Hopper, Screen Box and Granule Bin



Before opening the hopper, granule bin and screen box, switch both the main switch and granulator switch “Off”.



Be careful when the knives are accessible. They are sharp and can cause personal injury.

Opening the hopper

- 1 Check that the hopper is empty, then stop the granulator.
- 2 Undo the star knobs (A) on the hopper.
- 3 Undo the tip catch (B).

 **NOTE:** The hopper is counter-balanced with one alternative two gas springs, but hold the hopper at the same time, so that it does not fall down out of control.

- 4 Open/fold the hopper backwards.

Opening the screen box

- 1 Undo and pull out the extraction pipe from the rear of the granulator.
Alt. CLS series-machine with extraction fan, undo the quick coupling (D) on the outlet pipe stub.
- 2 Remove the granule bin (E).
- 3 Undo the star knobs (F) for the screen box (G)

 **NOTE:** Hold the screen box at the same time, so that it does not fall down out of control.

- 4 Fold the screen box down.
The screen is now accessible and can be lifted out for changing or cleaning.

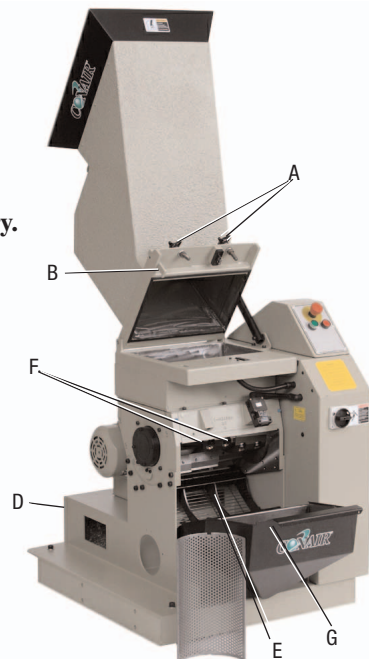

Closing the Screen Box, Granule Bin and Hopper



NOTE: Before closing, make sure that the mating surfaces are clean!



There is a pinch risk during closing, be careful!

Close the screen box and install the granule

- 1** Make sure that the screen is correctly positioned in the screen box.
- 2** Lift the screen box up and tighten the star knobs properly to stop.
- 3** Install the granule bin.
- 4** Install the extraction pipe.
Alt. CF series-machine with extraction fan, do up the quick coupling (D) on the outlet pipe stub.
- 5** Close the door.

Close the hopper

- 1** Check and make sure that no granulate lies on the mating surfaces or flanges.
- 2** Shut/fold back the hopper.
- 3** Open and make sure that the tipping catch falls into the cutout.
- 4** Lock the hopper with the star knobs, tighten the star knobs properly to stop.
- 5** Switch the main switch "On".
- 6** Start the granulator.



Operation and Daily Maintenance

Starting and Stopping	6-2
Inspection	6-3
Cleaning	6-4
Fault-Finding	6-6

Operation and Daily Maintenance

Starting and Stopping

The main switch is located beneath the control panel on the front of the granulator.

Starting and stopping is controlled by push buttons on the control panel.

 **NOTE:** Never stop the granulator before all material in the hopper and cutter housing is completely granulated.

Residual material will clog the rotor in the granulator during re-start. The motor will be overloaded and the overloading protection will trigger.

Emergency stop



Start Stop



Main switch

Inspection

There must be no plastic material left in the granulator when inspection is carried out.



NOTE: All servicing must be done by trained personnel in order to avoid personal injury and damage to the machine.

Daily Inspection

Flaps in the hopper. Check that the flaps are undamaged. Replace damaged flaps at once. Damaged flaps can drop down into the cutter housing and damage the knives. Damaged flaps also entail the risk of material ejection.

Emergency stop. Check the emergency stop function. Start the granulator and stop it with the emergency stop(s).

Reset. Turn the stop button in the direction of the arrow (anticlockwise).

Weekly Inspection

Cables. Check the electric cables of the machine for wear or other damage. Replace damaged cables at once.

Safety switches. Check the safety switch functions.

This granulator has 2 safety switches:

- 1 at the hopper
- 1 at the screen box

Check the hopper's safety switch.

Undo the star knobs on the hopper, and try to start the granulator.

The granulator should not be possible to start before the hopper has been closed and the star knobs are properly tightened to stop.

Check the screen box safety switch.

Undo the star knobs on the screen box and try to start the granulator.

The granulator should not be possible to start before the screen box has been closed and the star knobs are properly tightened to stop.



NOTE: The granule bin should be installed, and the door closed and locked.

Monthly Inspection

Check that the V-belts are undamaged.

Check the V-belt tension every 6 months, see Section 7.3 "Transmission".

Cleaning

Clean at colour change, monthly or at least once/300 hours.



Be careful when the hopper have been opened. The knives are now accessible, they are sharp, and can cause personal injury.

1 Check that the hopper is empty, then stop the granulator.



Switch “Off” both the main switch and the switch on the granulator.

2 Clean the outside of the hopper.

3 Undo the star knobs on the hopper.

4 Undo the tip chatch.

 **NOTE!** The hopper is counterbalanced with one alternative two gas springs, but hold the hopper at the same time, so that it does not fall down out of control.

5 Open/fold the hopper backwards.

6 Clean the hopper’s opening.

7 Lift out and clean the inner and outer flaps.

8 Open the door.

9 Undo and pull out the extraction pipe from the left-hand side of the granulator. Alt. machine with extraction fan model, undo the quick coupling on the outlet pipe stub.

10 Remove the granule bin.

11 Undo the star knobs for the screen box.

 **NOTE!** Hold the screen box at the same time, so that it does not fall down out of control.

12 Fold the screen box down.

13 Undo and clean the screen.

14 Undo and remove the blue screws (A) for the bearing cleaning holes.

15 Blow through the holes with compressed air and rotate the cutter at least one turn.

 **NOTE:** When the cutter is rotated manually, do this with great care. The knives are sharp and can cause personal injury.

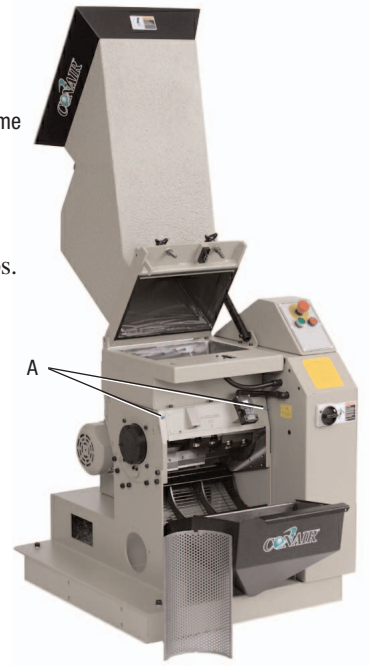

Cleaning (continued)



NOTE: Use protective goggles and make sure that no material blows into the safety switches!

- 16** Clean the granule bin and the screen box.
- 17** Clean the cutter housing inside and outside.
- 18** Clean any transport pipes, blower and cyclone.

Re-install after cleaning

- 1** Install the blue screws.
- 2** Install the screen in the screen box.
- 3** Lift up the screen box and and tighten the star knobs to stop.
- 4** Install the granule bin.
- 5** Install the extraction pipe.
Alt. CLS series-machine with extraction fan, do up the quick coupling on the outlet pipe stub.
- 6** Close the door.
- 7** Close the hopper. Check and make sure that no granulate remains .
on the mating flanges or surfaces.
- 8** Open and make sure that the tipping catch falls into the cutout.
- 9** Lock the hopper with the star knobs, tighten the knobs properly to stop.

Fault-Finding

The granulator does not start

- Check that the emergency stop is not activated.
Reset by turning the button(s) in the direction of the arrow (counterclockwise).
- Check that the hopper is properly closed.
The granulator will not start if the hopper not is properly closed.
Tighten the star knobs properly to stop.
- Check that the screen box is properly closed.

The granulator will not start, if the screen box not is properly closed.

Tighten the star knobs properly to stop.

- Check the overload circuit breaker for the motor.

The motor has an overload circuit breaker, F1, in the distribution box, which trips if you jam or over-load the motor.

This is indicated in the window (A) which shows “0”.

Reset, press the “Reset” button (B).

Check that there is no material left in the granulator before restarting.

- Granulator with blower (CLS series-machine with extraction fan). Check the blower overload circuit breaker. The granulator will not start if the blower does not start. The blower motor has an overload circuit breaker, F2, in the distribution box, which trips if you jam or overload the blower. This is indicated in the window (A) which shows “0”. Reset, press the “Reset” button (B). Check that there is no material left in the granulator before re-starting.

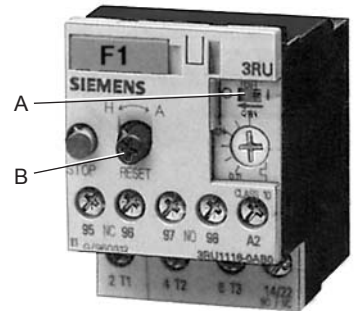

- Granulator with conveyor belt (CLS series-noise encapsulated machine with conveyor), if the conveyor belt does not start – check the conveyor belt overload circuit breaker.
The conveyor belt motor has an overload circuit breaker, F3, in the distribution box, which trips if you jam or overload the conveyor belt.
This is indicated in the window (A) which shows “0”.
Reset, press the “Reset” button (B).
Check that there is no material left on the band before re-starting.
- Check the granulator knives and knife tolerance.
If the granulator knives are blunt and unsharpened, or if the knife clearance is incorrect, this can result in stoppage. The granulator motor overload circuit breaker will trip. Check the knives.
Sharpen or replace the knives, or adjust the knife clearance, see next Section.

Check also the wiring diagram in Section 9; supplements and deviations may be applicable.

Service

Changing the Knives	7-2
Removing the knives	7-2
Installing the Knives	7-3
Transmission	
V-Belts, Inspection, and Adjustment	7-6
Lubrication	7-8
Cutter Pulley/Motor Pulley	7-9

Service

All service must be carried out by trained personnel in order to avoid personal injury or damage to the machine.

Changing the knives

Removing the knives

Check the screen for wear when the knives are changed. Change the screen when the holes begin to be pear shaped.



Be careful when handling the knives, they are sharp and can cause personal injury.



Use protective gloves!

Each time the knives are changed, the knife fastening screws must be replaced by new ones.

Changing the knives.

Open the hopper and any door. Remove the granule bin, then fold the screen box down and lift it out – see Section 5.3.

Removing the rotating knives.

- 1** Remove the screws (A) and washers (B), 2 each per knife. The knives are now loose.
- 2** Lift out the rotating knives.
- 3** Clean the surfaces where the knives were located.

Removing the fixed knives.

- 4** Undo the socket cap screws (C) on the front knife support rule (D).

 **NOTE:** Hold the fixed knife and support rule before removing the last screw.

- 5** Lift out the fixed knife together with the support rule.
- 6** Clean the knife location.
- 7** Put the support rule back loosely.

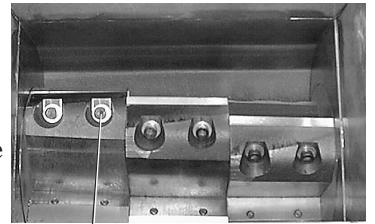

A, B

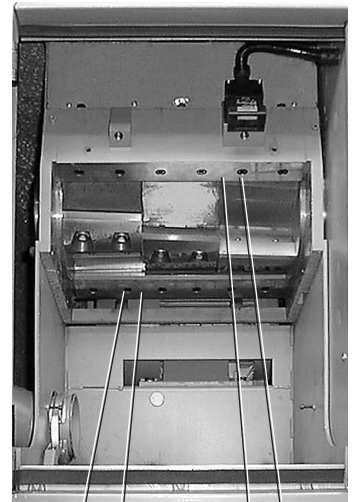

E F D C

- Undo and remove the socket cap screws (E) on the rear knife support rule (F).

 **NOTE:** Hold the fixed knife and support rule before removing the last screw.

- Lift out the fixed knife together with the support rule.
- Clean the knife location.
- Put the support rule back loosely.

Installing the Knives

The knife attachments for both the fixed and rotating knives must be carefully cleaned.

First install the rear, fixed knife

- Install the rear fixed knife on the knife attachment.
- Screw in the socket cap screws (E), so that the support rule (F) lightly supports the knife.
- Press the knife firmly into the knife attachment to bed it down.

 **NOTE:** The screws in the rear of the knife attachment are bonded in place.

 **NOTE:** The knife has a fixed position and no adjustment may be done.



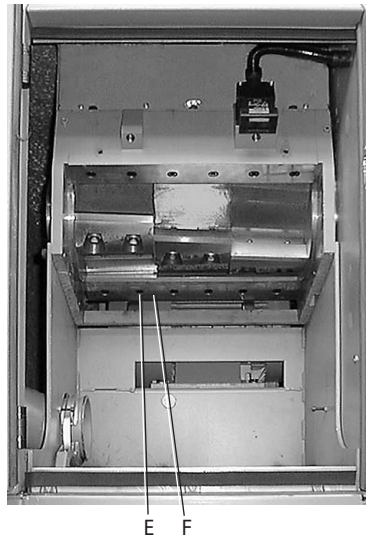

- Tighten screws (E), with alternating tightening torque to 29.5lb-ft (40 Nm).

Install the rotating knives.

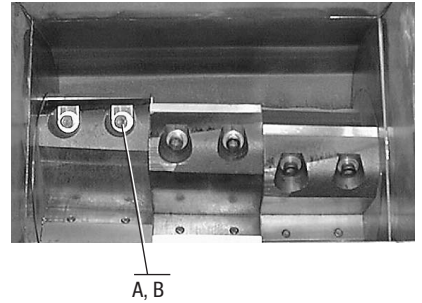

- 5** Install one rotating knife at a time on the knife attachment on the rotor.
- 6** Install screws (A) with washers (B), and tighten so that they hold the knife lightly.
- 7** Press the knife firmly into the knife attachment.



-  **NOTE:** The screws in the rear of the knife attachment are bonded in place.
-  **NOTE:** The knife has a fixed position and no adjustment may be done.
- 8** Tighten screws (A), with alternating tightening torque to 55.3 lb-ft (75 Nm).
 -  **NOTE:** Granulators with open cutter – tighten the screws (A) with alternating increased torque to 162.3 lb-ft (220 Nm).
 - 9** Check that the rotating knife can pass the rear fixed knife freely. If the knife can not pass freely – undo screws (A) and press the rotating knife firmly into the knife attachment. Undo screws (E) and press the fixed knife firmly into the knife attachment.
 - 10** Check the knife clearance with a feeler gauge. The clearance should be 0.008 - 0.012 in. (0.20 - 0.30 mm), check at the outer edges of the knives.
 - 11** Install all the rotating knives.
 - 12** Press the knife firmly into the knife attachment.
 - 13** Tighten the screws (A) with alternating increased torque to 55.3 lb-ft (75 Nm).
 -  **NOTE:** Granulators with open cutter – tighten the screws (A) with alternating increased torque to 162.3 lb-ft (220 Nm).
 - 14** Check that each rotating knife can pass the rear fixed knife freely. If any rotating knife can not pass freely – undo the screws (A) and press the knife firmly into the knife attachment.
 - 15** Check the clearance of each rotating knife with a feeler gauge. The clearance should be 0.008 - 0.012 in. (0.20 - 0.30 mm), check at the outer edges of the knives.

Then install the front, fixed knife

- 16** Install the knife in the knife attachment.
- 17** Screw in the socket cap screws (C) and tighten so that the support rule (D) lightly supports the knife.
- 18** Press the knife firmly into the knife attachment.



NOTE: The screws in the rear of the knife attachment are bonded in place.



NOTE: The knife has a fixed position and no adjustment may be done.

- 19** Tighten the screws (C), with alternating tightening torque to 29.5 lb-ft (40 Nm).
- 20** Carefully check that all rotating knives can pass the front fixed knife.

If any knife can not pass the front fixed knife freely – undo the screws (C) and press the knife firmly into the knife attachment.

- 21** Check the clearance of each rotating knife with a feeler gauge The clearance should be 0.008 - 0.012 in. (0.20 - 0.30 mm), check at the outer edges of the knives.
- 22** Re-check the tightening torque of all rotating knives (55.3 lb-ft [75 Nm]; granulator with open cutter 162.3 lb-ft [220 Nm]).
- 23** Re-check the tightening torque of the front and rear fixed knives (29.5 lb-ft [40 Nm]).



Transmission

V- Belts, Inspection, and Adjustment

The granulator is driven by 3 V-belts.

Checking the V-belts

The tension and condition of the V-belts must be checked after 20 - 30 hours of operation at full load.

After this, check the V-belts for damage once a month.

Check the belt tension every 6 months.

- Undo and remove the upper panel on the right-hand side of the granulator.
- Rotate the V-belts a few turns.

Check that the belts are intact, undamaged and uncracked.

- Check belt tension and adjust if necessary.

Motors up to 7.5 kW:

- Load each one of the belts in turn with 4.45 lbf. (20 N),

centrally between the cutter and belt pulleys. It should not be possible to depress the belt more than about 0.197 in. (5 mm).

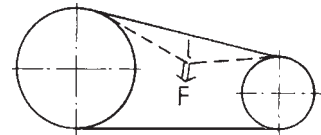

Motors up to 7,5 kW
L = 0.197in. (5 mm); F = 4.45lbf. (20 N)

11 kW motor
L = 0.197in. (5 mm); F = 6.07 lbf (27 N)

11 kW motor:

- Load each one of the belts in turn with 6.07 lbf. (27 N), centrally between the cutter and belt pulleys. It should not be possible to depress the belt more than about 0.197 in. (5 mm).



WARNING: Pinch risk between pulleys and V-belts.

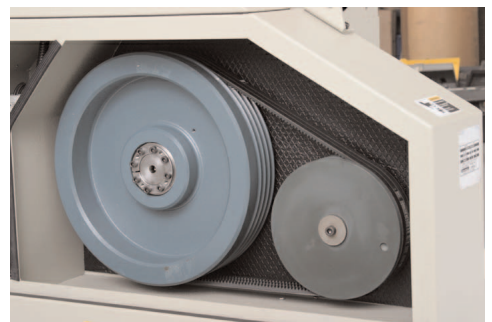

Transmission (continued)

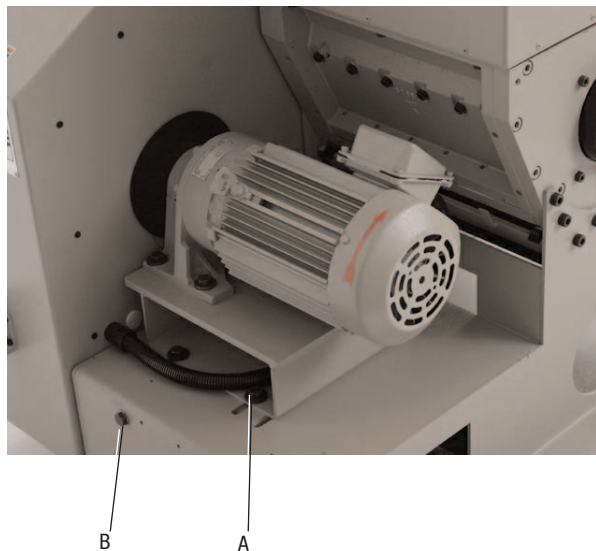

V-belt Adjustment

- Remove the upper panel on the right-hand side of the granulator.
- CLS series-noise encapsulated machine, remove the rear guard plate above the motor and open the door.
- Undo and remove the extraction pipe. Alt. CLS series-machine with extraction fan, undo the quick coupling on the outlet pipe stub.
- Remove the granule bin.
- Undo the motor screws (A) lightly, 4 pcs.
- Adjust the belt tension by increasing/reducing the distance of the motor to the cutter pulley, using the motor adjustment screws (B), 2 pcs.
- Tighten the motor screws (33.2lb-ft [45 Nm] torque)
- If the belt tension is adjusted, the belt need to be re-checked after 20 - 30 hours at full load.

Lubrication

Cutter Housing

The bearings in the cutter housing are permanently greased, and do not need greasing in normal circumstances.

Cutter Pulley/Motor Pulley

The upper panel on the right-hand side of the granulator must be removed to remove/install the cutter or motor pulleys.

This makes the cutter and motor pulleys accessible.

Removal

Cutter Pulley

The pulley is mounted with a compression bush.

- Undo all screws a few turns (8 pcs.)
- Remove two screws.
- Put a drop of oil into the extractor hole (A), and insert the two screws.
- Tighten the screws, using progressively increased torque until the compression bush comes away from the shaft.
- Lift off the cutter pulley, complete with the compression bush, from the shaft.

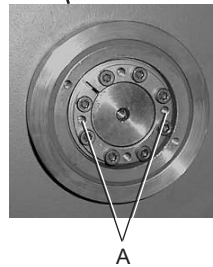
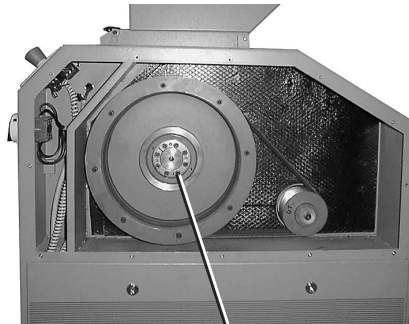

Motor Pulley

- Undo the socket cap screw on the pulley.
- Remove the pulley with a puller.

Installing

Motor Pulley

Lift the pulley onto the motor shaft, make sure that the key fits.

- Tighten the pulley with the socket cap screws on the shaft, 88.5lb-ft (120 Nm).

Cutter Pulley

The pulley is fitted with a compression bush.

- Clean and degrease the cutter pulley.
- Oil the cutter shaft.
- Oil the screws and fit the compression bush lightly on the pulley.
- Lift the pulley on to the cutter shaft.
- Make sure that the pulleys line up.
- Tighten the screws in the compression bush.
Tighten the screws alternately with the same torque, progressively increasing the torque to 14.8lb-ft (20 Nm).
- Tap the compression bush between the shaft and the screws.
Use a block of wood or plastic.
- Tighten the pulley with the compression bush.
Tighten the screws with alternating increased torque to 29.5lb-ft (40 Nm).

Spare Parts List

Cutting Chamber	8-3
Staggered Rotor	8-4
Knives	8-5
Transmission	8-6
Screen	8-8
Screen Box	8-8
Outfeed, Granule Bin Manual	8-9
Outfeed, Vacuum Suction/Blower	
F-7/F-5	8-10
Hopper	8-11
Hopper Device	8-12
Safety	8-12
Sound Cabin	8-13
Enclosure/Body	8-14

Spare Parts List

Ordering Spare Parts

Only use spare parts from Conair when replacing machine parts. Orders should go to the representative in the country where the machine was purchased.

When ordering, the following should be specified:

- Machine designation, as specified on the machine plate.
- Serial number, as specified on the machine plate.
- Part number, as specified in the spare parts list.
- Quantity, as specified in this spare parts list.

Cutting Chamber

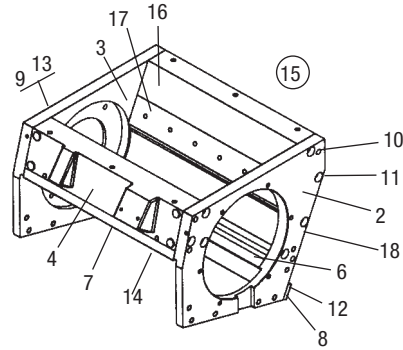

Pos	Qty.	Art. no.	Description	Pos	Qty.	Art. no.	Description
		3-029705	Cutter housing CLS-810			3-029705	Cutter housing CLS-810
		3-030254	- " - CLS-810 hardened			3-030254	- " - CLS-810 hardened
		3-029706	Cutter housing CF-814			3-029706	Cutter housing CF-814
		3-030255	- " - CLS-814 hardened			3-030255	- " - CLS-814 hardened
		3-029707	Cutter housing CLS-819			3-029707	Cutter housing CLS-819
		3-030256	- " - CLS-819 hardened			3-030256	- " - CLS-819 hardened
		3-029707	Cutter housing CLS-824			3-029707	Cutter housing CLS-824
		3-030256	- " - CLS-824 hardened			3-030256	- " - CLS-824 hardened
2	1	1-029513	Side, right	8	1	3-029524	Support, screen box
		4-030700	Side, right			3-029525	Support, screen box
3	1	1-029514	Side, left			3-029526	Support, screen box
		4-030701	Side, left	9	1	4-026380	Lid
4	1	1-029507	Front side	10	8	950079	Cylindric pin
		4-030702	Front side	11	14	940005	Socket cap screw
		1-029508	Front side	12	4	940104	Socket cap screw
		4-030703	Front side	13	4	940213	Socket cap screw
		1-029509	Front side	14	4	940743	Stop screw
		4-030704	Front side	15		3-029708	Cutter housing CLS-810 w 3:rd knife
		1-044912	Front side			3-030257	Cutter housing CLS-810 w 3:rd knife hardened
6	1	4-048231	Front side			3-029709	Cutter housing CLS-814 w 3:rd knife
		2-029518	Support rule, rear			3-030258	Cutter housing CLS-814 w 3:rd knife hardened
		4-030708	Support rule, rear			3-029710	Cutter housing CLS-819 w 3:rd knife
		2-029519	Support rule, rear			3-030259	Cutter housing CLS-819 w 3:rd knife hardened
		4-030709	Support rule, rear			3-044925	Cutter housing CLS-824 w 3:rd knife
		2-029520	Support rule, rear			3-048235	Cutter housing CLS-824 w 3:rd knife hardened
		4-030710	Support rule, rear	16	1	1-029554	Rear for 3:rd fixed knife
		2-044915	Support rule, rear			4-030243	Rear for 3:rd fixed knife
7	1	2-044915	Support rule, rear			1-029555	Rear for 3:rd fixed knife
		2-029521	Support rule, front			4-030244	Rear for 3:rd fixed knife
		4-030711	Support rule, front			1-029556	Rear for 3:rd fixed knife
		2-029522	Support rule, front			4-030245	Rear for 3:rd fixed knife
		4-030712	Support rule, front			1-044917	Rear for 3rd fixed knife
		2-029523	Support rule, front			4-048233	Rear for 3rd fixed knife, hardened
		4-030713	Support rule, front			2-029557	Support rule for 3:rd fixed knife
		2-044914	Support rule, front			4-030246	Support rule for 3:rd fixed knife
		2-044914	Support rule, front			2-029558	Support rule for 3:rd fixed knife
						4-030247	Support rule for 3:rd fixed knife
						2-029559	Support rule for 3:rd fixed knife
						4-030248	Support rule for 3:rd fixed knife
						2-044918	Support rule for 3:rd fixed knife
						2-044918	Support rule for 3:rd fixed knife
						940742	Socket cap screw
18	2			18	2		

Staggered Rotor

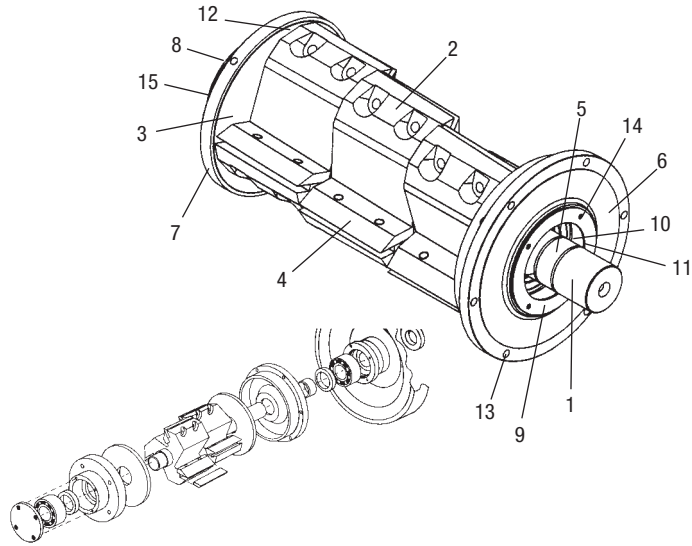

Pos	Qty.								Art. no.	Description
	┐	┐	┐	┐	┐	┐	┐	┐		
									3-29702	Cutter CLS-810 3-blade
									3-30260	Cutter CLS-810 3-blade hardened
									3-29703	Cutter CLS-814 3-blade
									3-30261	Cutter CLS-814 3-blade hardened
									3-29704	Cutter CLS-819 3-blade
									3-30262	Cutter CLS-819 3-blade hardened
									3-44926	Cutter CLS-824 3-blade
									3-48236	Cutter CLS-824 3-blade hardened
1	1	1							1-029530	Cutter shaft 3-blade
				1	1				1-029531	Cutter shaft 3-blade
						1	1		1-029532	Cutter shaft 3-blade
								1	3-044919	Cutter shaft 3-blade
2	2	2	3	3	4	4	5	5	3-029501	Segment
3	2	2	2	2	2	2	2	2	3-029502	Ring
		2		2					4-030249	Ring
4	6		9		12		15		3-029504	Support rule
		6		9				15	4-030250	Support rule
5	1	1	1	1	1	1	1	1	4-029529	Sleeve
6	1	1	1	1	1	1	1	1	2-029505	Plummer block, right
		1		1		1		1	2-030714	Plummer block, right
7	1	1	1	1	1	1	1	1	2-029506	Plummer block, left
		1		1		1		1	2-030715	Plummer block, left
8	1	1	1	1	1	1	1	1	3-029527	Lid, left
9	1	1	1	1	1	1	1	1	4-029528	Lid, right
10	2	2	2	2	2	2	2	2	960182	Bearing
11	2	2	2	2	2	2	2	2	960183	Sealing ring
12	6	6	6	6	6	6	6	6	940579	Socket cap screw
13	6	6	6	6	6	6	6	6	940007	Socket cap screw
14	8	8	8	8	8	8	8	8	940071	Socket cap screw
15	4	4	4	4	4	4	4	4	940032	Socket cap screw

Knives

Pos	Qty.					Art. no.	Description	Note
	1	2	3	4	5			
1	6	9	12	15		3-029503	Knife, rotating	
2	2	2	2			2-029515	Knife, fixed	
			2			2-029516	Knife, fixed	
				2		2-029517	Knife, fixed	
3	1					3-044922	Knife, fixed	
		1				2-029515	Knife, third fixed	
			1			2-029516	Knife, third fixed	
				1		2-029517	Knife, third fixed	
					1	3-044922	Knife, third fixed	
4	12	18	24	30		940004	Socket cap screw	
5	12	18	24	30		940031	Washer	
6	8	12	16	20		940778	Socket cap screw	
7	4	6	8	10		940779	Socket cap screw	for 3:rd fixed knife

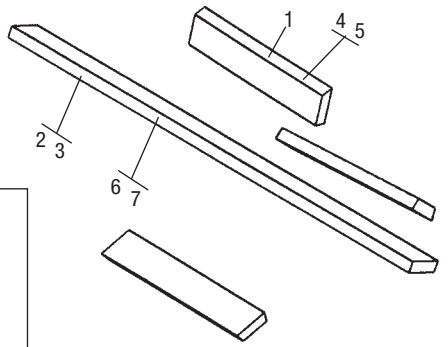

Transmission - Standard on CLS models 810/814

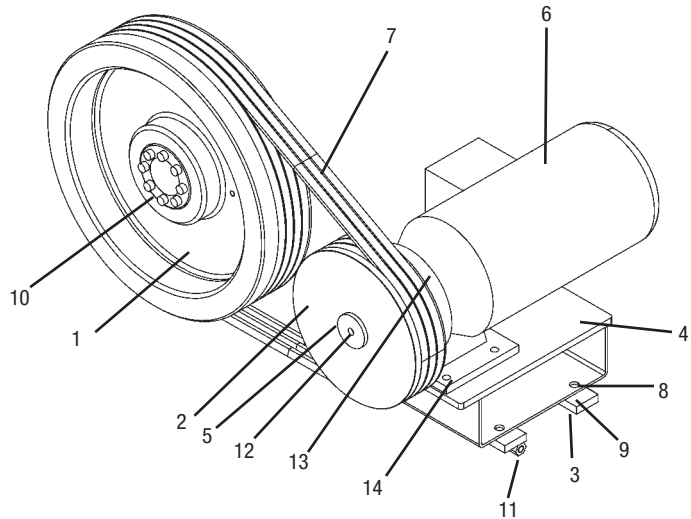

Pos	Qty.	Art. no.	Description
	┌	3-4450	Transmission 2.2 kW 240 rpm 400 V
1	1	1-030133	Cutter pulley
2	1	3-044517	Motor pulley
3	2	3-029552	Belt tensioner
4	1	3-044519	Distance H=90
5	1	4-043674	Washer
6	1	993149	Motor 2.2 kW
7	3	992652	V-belt
8	4	930092	Screw
9	10	940031	Washer
10	1	930222	Coupling
11	2	940744	Screw
12	1	940052	Screw
13	1	970295	Sealing Ring
14	4	940041	Socket cap screw

**Transmission - Optional on CLS models 810/814
Standard on CLS models 819/824**

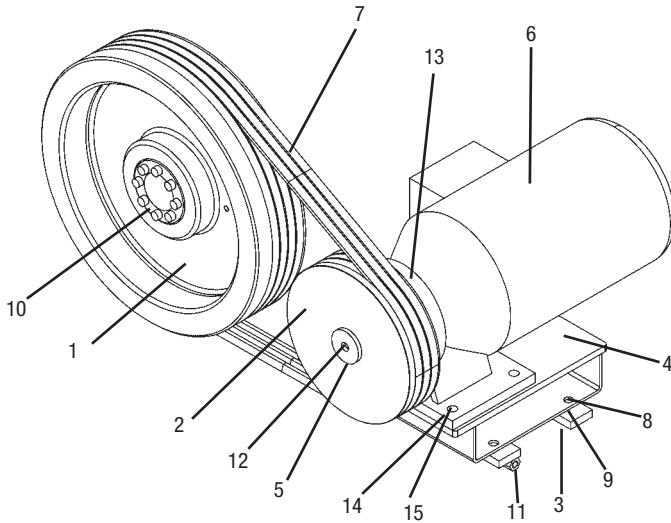

Pos	Qty.	Art. no.	Description
	┌	3-44521	Transmission 4 kW 240 rpm 400 V
1	1	1-030133	Cutter pulley
2	1	3-044518	Motor pulley
3	2	3-029552	Belt tensioner
4	1	3-037125	Distance H=70
5	1	4-044522	Washer
6	1	993150	Motor 4.0 kW
7	3	992652	V-belt
8	4	930092	Screw
9	6	940031	Washer
10	1	930222	Coupling
11	2	940744	Screw
12	1	940051	Screw
13	1	970295	Sealing Ring
14	4	940816	Washer
15	4	940306	Screw

Screen

Pos	Qty.	Art. no.	Description	Note
	┌		Granulator CLS-810	
	┌		Granulator CLS-814	
	┌		Granulator CLS-819	
	┌		Granulator CLS-824	
1	1	3-29574	Screen	
	1	3-31688	Screen	stitch reduced
	1	4-30251	Screen hardened	
	1	4-31691	Screen hardened	stitch reduced
	1	3-29575	Screen	
	1	3-31689	Screen	stitch reduced
	1	4-30252	Screen hardened	
	1	4-31692	Screen hardened	stitch reduced
	1	3-29576	Screen	
	1	3-31690	Screen	stitch reduced
	1	4-30253	Screen hardened	
	1	4-31693	Screen hardened	stitch reduced
	1	3-46065	Screen	
	1	3-48239	Screen	stitch reduced
	1	4-48238	Screen Hardened	
	1	4-48240	Screen Hardened	stitch reduced

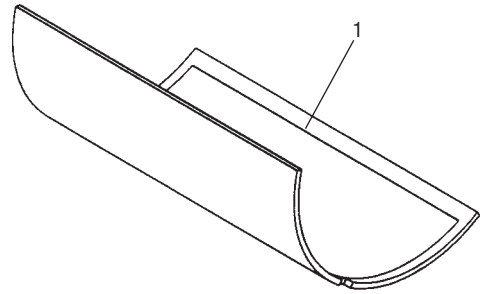

 NOTE: Specify art no. and required hole diameter, Ø 4, 6, 8 or 10 mm.

Screen Box

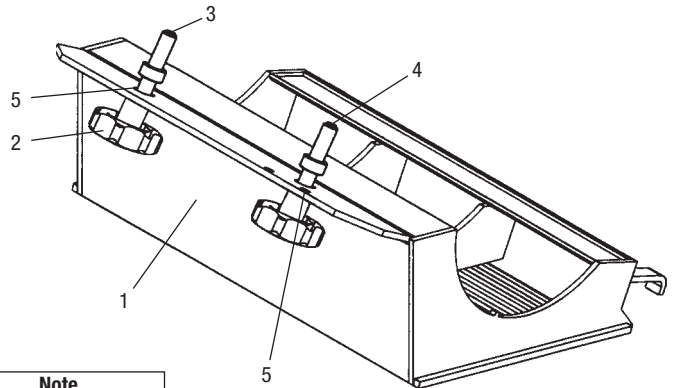

Pos	Qty.	Art. no.	Description	Note
	┌		Granulator CLS-810	
	┌		Granulator CLS-814	
	┌		Granulator CLS-819	
	┌		Granulator CLS-824	
1	1	1-29560	Screen box	
	1	1-29566	Screen box	stitch reduced
	1	1-29561	Screen box	
	1	1-29657	Screen box	stitch reduced
	1	1-29562	Screen box	
	1	1-29658	Screen box	stitch reduced
	1	1-44970	Screen box	
	1	3-48246	Screen Box	stitch reduced
2	2	950532	Star knob	
3	1	4-30327	Locking bolt	
4	1	4-30328	Locking bolt	
5	4	940155	Washer	

Granule Bin Manual (optional)

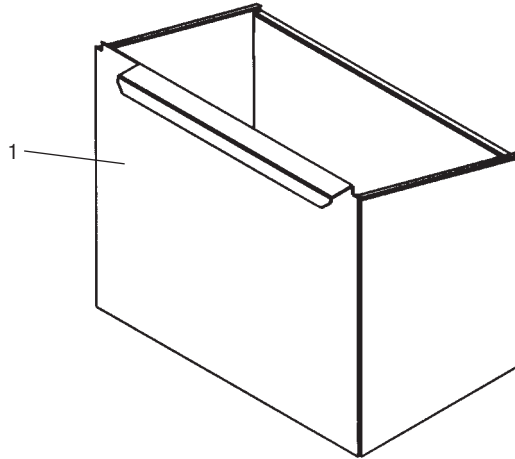

Pos	Qty.	Art. no.	Description	Note.
	┌		Granulator CLS-810	
	┌		Granulator CLS-814	
	┌		Granulator CLS-819	
	┌		Granulator CLS-824	
1	1	1-29577	Granule bin	manual 15 L
	┌	1-29578	Granule bin	manual 22 L
	┌	1-29579	Granule bin	manual 29 L
	┌	1-47106	Granule bin	manual 36 L

Vaccum Suction /Blower F-7/F-15

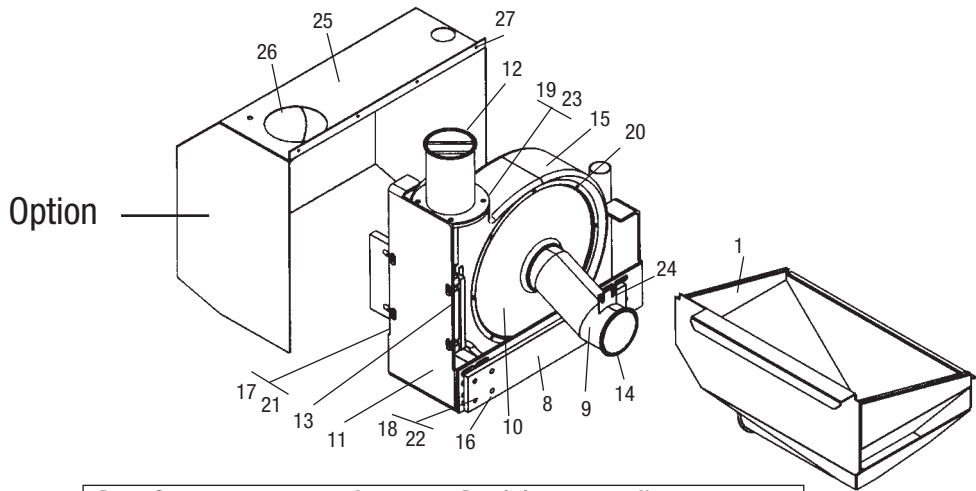

Pos	Qty.	Art. no.	Description	Note.
			Granulator CLS-810	
			Granulator CLS-814	
			Granulator CLS-819	
			Granulator CLS-824	
1	1	3-44717	Granule bin	vaccum/blower
		3-44509	Granule bin	vaccum/blower
		3-44718	Granule bin	vaccum/blower
		1-44975	Granule bin	vaccum/blower
8	1	3-29759	Distance	
9	1	2-29639	Pipe stub D-100	
10	1	3-30267	Pipe stub, inlet	
11	1	1-22825	Holder, blower	
12	1	3-13138	Pipe stub, outlet	F7
		3-10332	Pipe stub, outlet	F15
13	1	4-24655	Holder, blower	
14	1	920415	Quick coupling ring	
15	1	920206	Blower F7/D4	
		920421	Blower F15/D6	
16	4	940347	Socket cap screw M10	
17	4	940004	Socket cap screw M10	
18	4	940201	Socket cap screw M10	
19	4	940426	Screw M8	
20	8	940039	Socket cap screw M6	
21	6	940015	Nut M10	
22	8	940031	Washer BRB	
23	4	940592	Washer BRB FZB	
24	2	940213	Socket cap screw M6	
25	1	1-22824	Cover, blower	
26	1	970152	Sealing ring	
27	8	940147	Screw	

Hopper

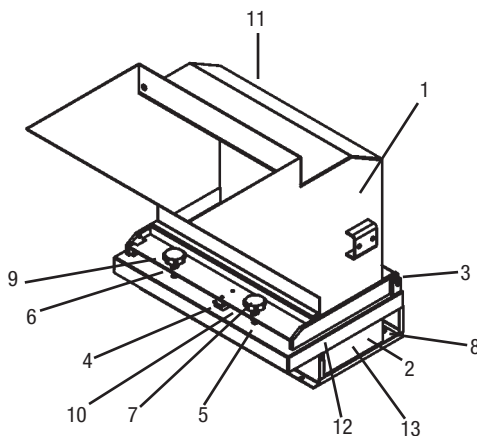
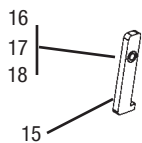
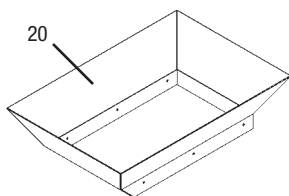

Pos	Qty.	Art. no.	Description	Pos	Qty.	Art. no.	Description
1	1	2-44873	Hopper, front	14	1	970148	List
		2-44695	Hopper, front	15	1	4-30093	Stop double
		2-44881	Hopper, front	16	1	4-22129	Distance
		2-46067	Hopper, front	17	1	940162	Washer BRB
2	1	1-29595	Frame	18	1	940662	Socket cap screw M8
		1-29596	Frame	20	1	3-44763	Flare
		1-29597	Frame			3-44759	Flare
		1-046075	Frame			3-44878	Flare
3	1	4-30495	Shaft			3-46079	Flare
		4-29734	Shaft	21	4	940587	Socket cap screw M8
		4-30628	Shaft	22	1	970141	List
		4-046076	Shaft	24	1	3-44765	Flaps, cloth
4	1	4-29646	Bracket, key			3-44762	Flaps, cloth
5	1	4-30327	Locking bolt M12			3-44876	Flaps, cloth
6	1	4-30328	Locking bolt M12			3-46077	Flaps, cloth
7	2	950532	Star knob				
8	6	940097	Socket cap screw M8				
9	2	940071	Socket cap screw M5				
10	4	940155	Washer BRB FZB				
11	1	940696	Stop screw				
12	1	970141	List				
13	1	970218	List				

Hopper Device

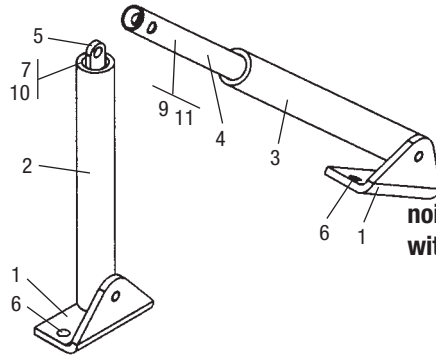

noise encapsulated machine
with extraction fan

Pos	Qty.				Art. no.	Description	Note.
	Γ	Γ	Γ	Γ			
						Hopper device, granulator CLS-810- noise encapsulated machine with extraction fan	for hopper 2-44873
						Hopper device, granulator CLS-814- noise encapsulated machine with extraction fan	for hopper 2-44695
						Hopper device, granulator CLS-819- noise encapsulated machine with extraction fan	for hopper 2-44881
						Hopper device, granulator CLS-824- noise encapsulated machine with extraction fan	for hopper 2-46067
1	2	2	2	2	3-29777	Bracket	
2	1	1	1	1	3-30325	Sleeve	
3	1	1	1	1	3-29779	Sleeve	
4	1	1	1	1	3-30326	Sleeve	
5	1	1	1	1	920768	Gas spring	
6	4	4	4	4	940032	Socket cap screw M8	
7	4	4	4	4	940200	Socket cap screw M8	
9	2	2	2	2	940585	Washer	
10	7	7	7	7	940016	Nut	
11	1	1	1	1	950430	Sealing end	

8.15 Safety

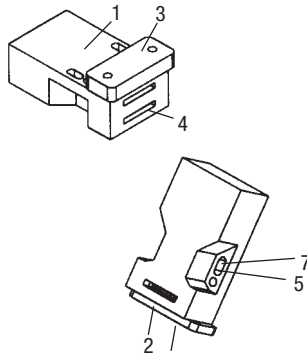

Pos	Qty.				Art. no.	Description
	Γ	Γ	Γ	Γ		
						Granulator CLS-810
						Granulator CLS-814
						Granulator CLS-819
						Granulator CLS-824
1	2	2	2		911002	Switch
2	1	1	1		911003	Breaking key
3	1	1	1		911004	Breaking key
4	6	6	6		911005	Cover washer
5	4	4	4		940076	Socket screw
6	4	4	4		940611	Socket screw
7	6	6	6		940267	Nut

Sound Cabin

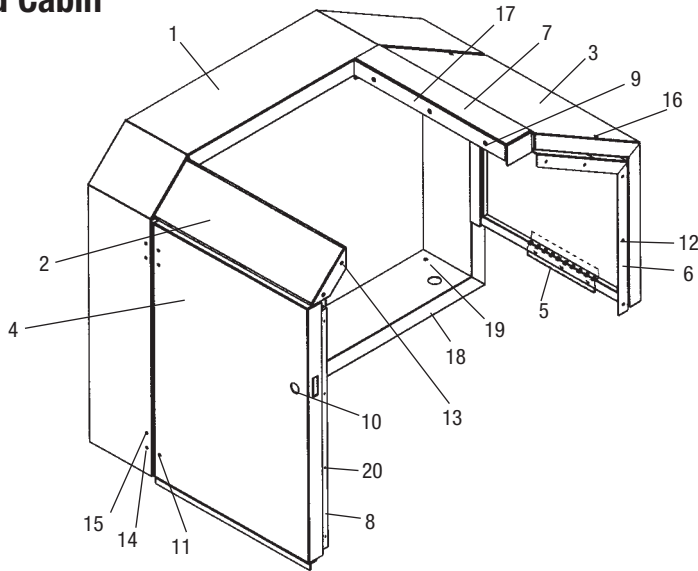

Pos	Qty.				Art. no.	Description
	Γ	Γ	Γ	Γ		
						Granulator CLS-810-noise encapsulated machine
						Granulator CLS-814-noise encapsulated machine
						Granulator CLS-819-noise encapsulated machine
						Granulator CLS-824-noise encapsulated machine
1	1	1	1	1	1-29581	Cover, left
2	1				2-29583	Cover, front
		1			2-29584	Cover, front
			1		2-29585	Cover, front
				1	2-46146	Cover, front
3	1				2-29586	Cover, rear
		1			2-29587	Cover, rear
			1		2-29588	Cover, rear
				1	1-46147	Cover, rear
4	1				2-29589	Door
		1			2-29590	Door
			1		2-29591	Door
				1	1-46148	Door
5	1	1	1	1	3-29592	Holder, rear
6	1	1	1	1	2-29593	Bracket, cover, rear
7	1				2-29613	Border
		1			2-29614	Border
			1		2-29615	Border
				1	2-46149	Border
8	1	1	1	1	329655	List
9	3	3	3	3	940032	Socket cap screw
10	1	1	1	1	950555	Lock, door lock
11	2	2	2	2	950533	Hinge
12	5	5	5	5	940261	Rivet
13	4	4	4	4	950557	Nut, blind rivet
14	8	8	8	8	950556	Nut, blind rivet
15	8	8	8	8	940076	Socket cap screw M5
16	2	2	2	2	940054	Socket cap screw M8
17	1	1	1	1	970218	List
18	1	1	1	1	970148	List
19	15	15	15	15	940213	Socket cap screw M6
20	4	4	4	4	940257	Rivet

8.17 Enclosure/Body

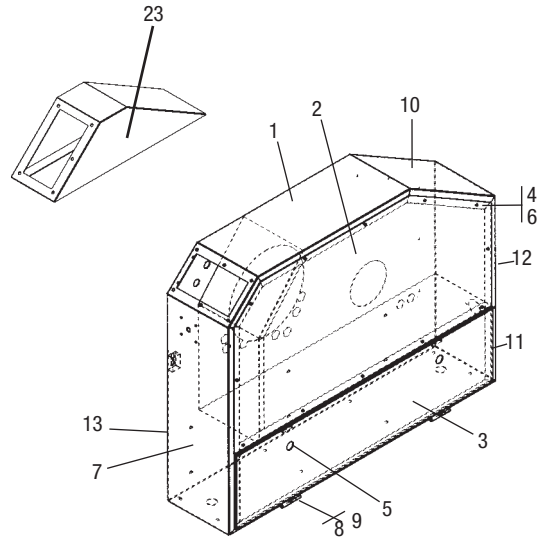
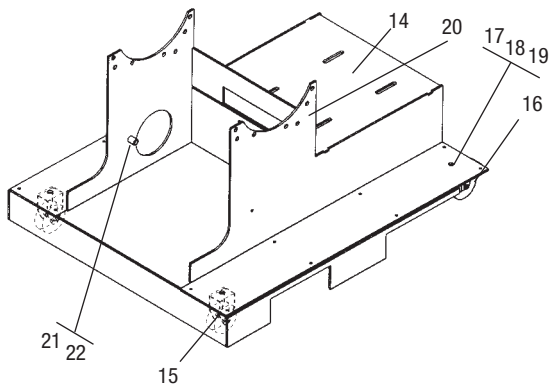

Pos	Qty.				Art. no.	Description
	Γ	Γ	Γ	Γ		
1	1	1	1	1	1-29542	Granulator CLS-810 Cover, transmission
2	1	1	1	1	2-29582	Granulator CLS-814 Lid
3	10	10	10	10	940213	Granulator CLS-819 Socket cap screw
4	12	12	12	12	940647	Granulator CLS-824 Torx screw
5	2	2	2	2	991567	Lock, door lock
6	12	12	12	12	950269	Nut, blind fastening
7	6	6	6	6	950321	Nut, blind fastening
8	1	1	1	1	4-30274	Stop, door
9	2	2	2	2	940027	Nut M6
10	1	1	1	1	970195	Noise absorber
11	1	1	1	1	970218	List
12	1	1	1	1	970141	List
13	1	1	1	1	970148	List
14	1				1-29539	Bottom plate
		1			1-29540	Bottom plate
			1		1-29541	Bottom plate
				1	1-46145	Bottom plate
15	2	2	2	2	950148	Wheel, fixed
16	2	2	2	2	950147	Wheel, foot brake
17	4	4	4	4	940051	Socket cap screw
18	4	4	4	4	940024	Nut
19	4	4	4	4	940155	Washer
20	14	14	14	14	940037	Socket cap screw
21	2	2	2	2	4-30076	Distance
22	2	2	2	2	940104	Socket cap screw
23	1	1	1	1	2-44514	Push button mounting bracket

Wiring Diagram

Wiring Diagram	9-2
Current sensing relay	9-3
Connection	9-4
Example	9-5

Wiring diagram

Never change or modify the basic electrical settings of the granulator, without first obtaining permission from Conair.

If the granulator settings are changed, the machine can be seriously damaged. All Warranties and Conair's Product Liability will be void, if the basic settings of the granulator are changed. All maintenance and service work must be done by trained and competent personnel!

Electrical installation must only be done by a competent electrician!
The distribution box of the granulator is located on the right, low down.

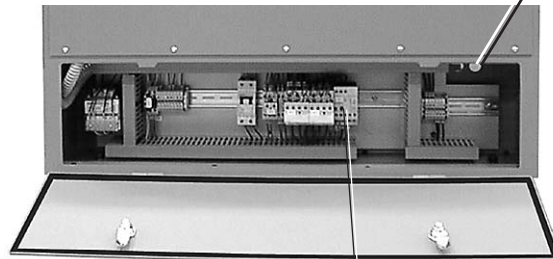
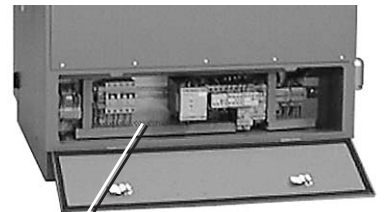

CLS series-noise encapsulated machine

Motor overload circuit breaker (F1)

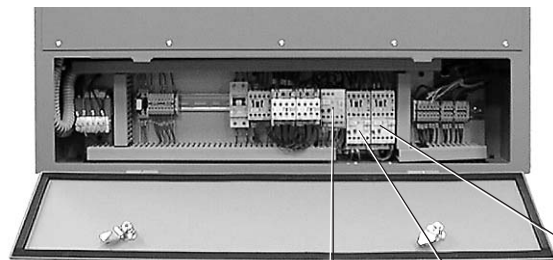

CLS series-noise encapsulated machine with conveyor

Motor overload circuit breaker (F1)

Blower overload circuit breaker (F2)

Conveyor belt overload circuit breaker (F3)

Current Sensing Relay

The granulator can be equipped with an optional current sensing relay to control the feed equipment.

The current sensing relay detects the mill motor current consumption and can temporarily stop accessories such as conveyors, roller feeders etc to avoid putting further material into the hopper, when the mill is running under heavy loading.

The relay stops and re-starts accessory equipment automatically, without re-setting.

Relay functions and normal settings:

- T1 – Start delay, prevents the relay from breaking on connection (0.1 - 10 sec).
The default start delay is 0.1 seconds.
- T2 – Reaction time, prevents the relay from breaking during temporary high loading (0.1 - 3 sec).
Default reaction time is 3.0 seconds.
- A – Hysteresis, adjustable between 5 - 50% of the set limit.
Default hysteresis is 20 %.
- B – Limit value, adjustable between 0 - 100 %.
Default setting depends on the current transformer size.
Check the current transformer size and then check the default setting for this granulator.
- C – Relay function, N = normal; I = inverted;

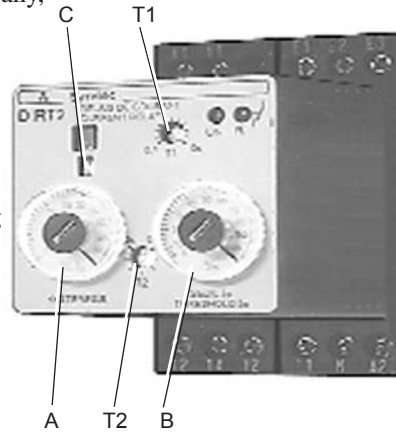

Connection

The current sensing relay is connected in series with the mill motor via a current transformer.

The transformer is connected between M and E1/E2/E3 depending on the secondary current.

(For transformers with transformation to 1 A, this is connected to E2.)

Default setting for this granulator:

Granulator motor, rated current: $\sqrt{3}$ = A
 Current transformer: /1A
 Start delay T1: 0,1 sec. other value:
 Reaction time T2: 3,0 sec. other value:
 Limit values: % = A
 Hysteresis: % = A

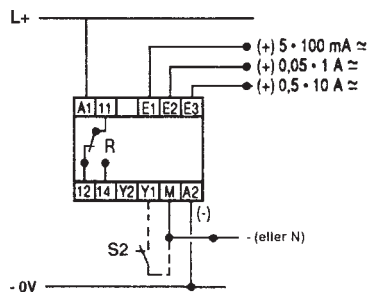

Example

The granulator is equipped with a current sensing relay to control a conveyor.

A motor of 7.5 kW has a rated current of about 15 A.

When this star/delta is started, it pulls about $15 A/\sqrt{3}$ i.e. about 9 A per phase.

Relay Setting:

Motor size $15 A/\sqrt{3} = 8,7 A$ per phase

T1 – Start delay setting 0.1 second.

T2 – Reaction time setting 3.0 seconds.

A – Hysteresis 20 %.

B – Limit value 30 %.

C – Relay function N normal.

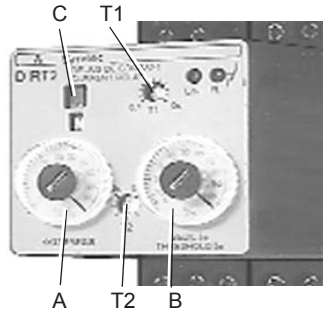

- The current transformer size is 30/1A.
- The current transformer is connected to E2 (1 A).
- In a current transformer with a transformation ratio of 30/1, the limit value B should be set to 30 % or 9 A (30 A = 100 %).
- The current sensing relay detects the current consumption of the granulator motor and stops the conveyor, when the granulator motor exceeds 9 A for 3 seconds, to prevent further material from being fed into the hopper.
- The relay re-starts the conveyor automatically when the granulator motor consumption has fallen 20 % below 9 A, i.e. to 7 A without a time delay.

Accessories

Ordering Spare Parts 10-2
Third Fixed Knife, Removing, Installing . . . 10-3

Accessories

Ordering Spare Parts

Only use original Conair spare parts when replacing machinery components. Orders should be sent to the representative in the country where the machine was purchased.

When ordering spare parts, please specify:

- Machine type/designation, on the machine's rating plate.
- Serial number, on the machine's rating plate.
- Part number, from this list of spare parts.
- Number of components.

Third Fixed Knife

As an optional extra, the granulator can be equipped with a third fixed knife to increase the efficiency of the granulator.

Open the hopper to install/remove the third fixed knife.

CLS series-noise encapsulated machine, remove the rear guard plate over the motor and open the door.

Removal

- 1 Undo and remove the screws (A) which hold the knife.
- 2 Remove the knife (B).
- 3 Clean the knife attachments where the knife was installed.

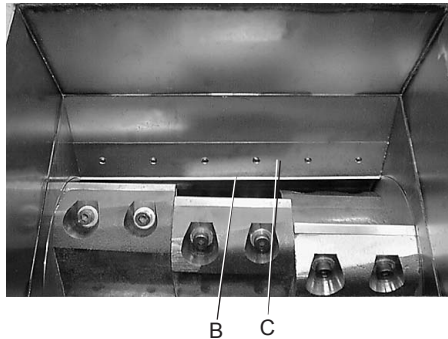

Installation

- 1 Install the knife on the knife attachment.
- 2 Screw in the socket cap screws (A), so that the support rule (C) lightly supports the knife.
- 3 Press the knife firmly into the knife attachment to bed it down.

 **NOTE:** The screws in the rear of the knife attachment are bonded in place.

 **NOTE:** The knife has a fixed position and no adjustment may be done.

- 4 Tighten the screws (A), with an alternating tightening torque to 29.50 lb-ft (40 Nm).

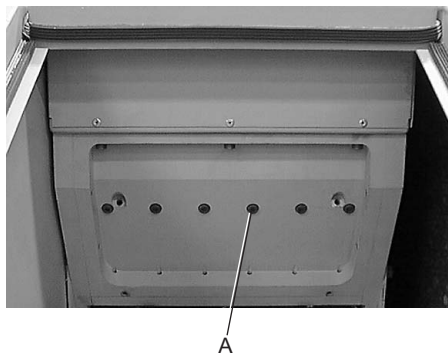

Sharpening

The third fixed knife is disposable and is changed when necessary.

Transport and Storage

General	11-2
Unpacking and Checking	11-2
Lifting and Transport to Place of Use	11-2
Positioning in Place of Use	11-2
Storage	11-3
Long-Term Storage/Conservation	11-3

Transport and storage

General

The machine should be transported by trained personnel.

The machine is delivered packed in protective plastic foil, fixed to a pallet with straps.

Unpacking and Checking

- Check that the machine has not been damaged during transport.

 **NOTE: Report any damage to the forwarding agent.**

- Do not unpack the machine before it has been transported to where it is going to be used.
- Check with the delivery note that the delivery is complete.

Positioning in Place of Use

See Installation, Section 5.



Storage

The machine is packed for transport to the place where it is to be used. On delivery it is protected with Castrol DWX 22 anti-rust oil.

Long-Term Storage/Conservation

- Store the machine in a room with a stable, dry temperature.
- Treat the unpainted surfaces of the machine with rust preventer, such as Castrol DWX 22. DWX 22 will protect the machine up to 12 months. Alternatively, DWX 160 will provide protection for 24 - 36 months.

We're Here to Help

Conair has made the largest investment in customer support in the plastics industry. Our service experts are available to help with any problem you might have installing and operating your equipment. Your Conair sales representative also can help analyze the nature of your problem, assuring that it did not result from misapplication or improper use.



Additional manuals and prints for your Conair equipment may be ordered through the Customer Service or Parts Department for a nominal fee.

How to Contact Customer Service

To contact Customer Service personnel, call:



From outside the United States, call: 814-437-6861

You can commission Conair service personnel to provide on-site service by contacting the Customer Service Department. Standard rates include an on-site hourly rate, with a one-day minimum plus expenses.

Before You Call...

If you do have a problem, please complete the following checklist before calling Conair:

- Make sure you have all model, serial and parts list numbers for your particular equipment. Service personnel will need this information to assist you.
- Make sure power is supplied to the equipment.
- Make sure that all connectors and wires within and between control systems and related components have been installed correctly.
- Check the troubleshooting guide of this manual for a solution.
- Thoroughly examine the instruction manual(s) for associated equipment, especially controls. Each manual may have its own troubleshooting guide to help you.
- Check that the equipment has been operated as described in this manual.
- Check accompanying schematic drawings for information on special considerations.

Equipment Guarantee

Conair guarantees the machinery and equipment on this order, for a period as defined in the quotation from date of shipment, against defects in material and workmanship under the normal use and service for which it was recommended (except for parts that are typically replaced after normal usage, such as filters, liner plates, etc.). Conair's guarantee is limited to replacing, at our option, the part or parts determined by us to be defective after examination. The customer assumes the cost of transportation of the part or parts to and from the factory.

Performance Warranty

Conair warrants that this equipment will perform at or above the ratings stated in specific quotations covering the equipment or as detailed in engineering specifications, provided the equipment is applied, installed, operated and maintained in the recommended manner as outlined in our quotation or specifications.

Should performance not meet warranted levels, Conair at its discretion will exercise one of the following options:

- Inspect the equipment and perform alterations or adjustments to satisfy performance claims. (Charges for such inspections and corrections will be waived unless failure to meet warranty is due to misapplication, improper installation, poor maintenance practices or improper operation.)
- Replace the original equipment with other Conair equipment that will meet original performance claims at no extra cost to the customer.
- Refund the invoiced cost to the customer. Credit is subject to prior notice by the customer at which time a Return Goods Authorization Number (RGA) will be issued by Conair's Service Department. Returned equipment must be well crated and in proper operating condition, including all parts. Returns must be prepaid.

Purchaser must notify Conair in writing of any claim and provide a customer receipt and other evidence that a claim is being made.

Warranty Limitations

Except for the Equipment Guarantee and Performance Warranty stated above, Conair disclaims all other warranties with respect to the equipment, express or implied, arising by operation of law, course of dealing, usage of trade or otherwise, including but not limited to the implied warranties of merchantability and fitness for a particular purpose.