

USER GUIDE  
UGH024-0907

# Portable Chillers

Water-cooled models PCW-1.5 to PCW-30

and Air-cooled models PCA1.5 to PCA-30



**INTRODUCTION** • Purpose of the User Guide • How the guide is organized • Your responsibilities as a user • **ATTENTION:** Read this so no one gets hurt • **DESCRIPTION** • What is the Portable Chiller? • Typical applications • Limitations • How it works • Specifications: Portable Chillers • **INSTALLATION** • Unpacking the boxes • Warnings and cautions • Preparing for installation • Making process plumbing connections • Filling the chiller • Checking the refrigerant charge • Connecting the main power source • Checking electrical connections • Checking pump rotations • Checking the compressor • Checking the sight glass • Initially warming the chiller • Checking for leaks • Initially running the chiller • Stopping the chiller • **OPERATION** • TIC control features • PLC control features • Before starting • Starting/stopping the chiller • Changing settings • Changing the setpoint temperature • Menu features • Tuning the chiller • Powering up • Running/stopping the chiller • Viewing chiller status screens • Programming settings • Changing setpoint •

Please record your equipment's model and serial number(s) and the date you received it in the spaces provided.

It's a good idea to record the model and serial number(s) of your equipment and the date you received it in the User Guide. Our service department uses this information, along with the manual number, to provide help for the specific equipment you installed.

Please keep this User Guide and all manuals, engineering prints and parts lists together for documentation of your equipment.

Date:

---

Manual Number: UGH024-0907

---

Serial Number(s):

---

Model Number(s):

---

**DISCLAIMER:** The Conair Group, Inc., shall not be liable for errors contained in this User Guide or for incidental, consequential damages in connection with the furnishing, performance or use of this information. Conair makes no warranty of any kind with regard to this information, including, but not limited to the implied warranties of merchantability and fitness for a particular purpose.

# Table of Contents

## 1-1 Introduction

Purpose of the user guide . . . . .	1-2
How the guide is organized . . . . .	1-2
Your responsibilities as a user . . . . .	1-3
ATTENTION: Read this so no one gets hurt . . . . .	1-4

## 2-1 Description

What is the Portable Chiller? . . . . .	2-2
Typical applications . . . . .	2-3
Limitations . . . . .	2-3
How it works: Water-cooled Portable Chillers . . . . .	2-4
How it works: Air-cooled Portable Chillers . . . . .	2-6
Portable Chiller features . . . . .	2-8
Pump curves . . . . .	2-10

## 3-1 Installation

Unpacking the boxes . . . . .	3-2
Warnings and cautions . . . . .	3-3
Preparing for installation . . . . .	3-4
Making process plumbing connections . . . . .	3-5
Filling the Chiller . . . . .	3-8
Checking refrigerant charge . . . . .	3-10
Connecting the main power source . . . . .	3-11
Checking electrical connections . . . . .	3-12
<u>TIC CONTROL</u>	
Checking pump rotation . . . . .	3-13

Checking the compressor . . . . .	3-13
Checking the water level gauge . . . . .	3-13
<u>PLC CONTROL</u>	
Initially warming the Chiller . . . . .	3-14
Checking the pump for rotation . . . . .	3-15
Checking for leaks . . . . .	3-16
Initially starting the Chiller . . . . .	3-17
Stopping the Chiller . . . . .	3-18

## 4-1 Operation

TIC control features . . . . .	4-2
PLC control features . . . . .	4-3
Before starting . . . . .	4-4
<u>TIC CONTROL</u>	
Starting/stopping the Chiller . . . . .	4-7
Changing settings . . . . .	4-7
Changing the setpoint temperature . . . . .	4-8
Menu features . . . . .	4-8
Tuning the Chiller . . . . .	4-9
<u>PLC CONTROL</u>	
Powering up . . . . .	4-16
Setup menu . . . . .	4-17
Running/stopping the Chiller . . . . .	4-18
Viewing Chiller run menu . . . . .	4-18
Changing setpoint temperature . . . . .	4-21
Changing high temperature deviation . . . . .	4-22
Setting percent glycol . . . . .	4-23
Selecting the temperature scale . . . . .	4-25
Resetting PID settings . . . . .	4-26
Setting fan setpoints . . . . .	4-27

Setting discharge pressure setpoint . . . . .	4-29
Setting PID values . . . . .	4-30
Manually starting/stopping the pump . . . . .	4-31

## 5-1 Maintenance

Maintenance features . . . . .	5-2
Warnings and cautions . . . . .	5-3
Preventative maintenance schedule . . . . .	5-4
PLC control entering maintenance screens . . . . .	5-6
Checking electrical connections . . . . .	5-7
Cleaning the evaporator brazed plate or water-cooled condenser . . . . .	5-8
Cleaning the air-cooled condenser . . . . .	5-9
Checking the refrigerant charge . . . . .	5-10
Checking the reservoir level . . . . .	5-11
PLC control setting auto tune mode . . . . .	5-12

## 6-1 Troubleshooting

Before beginning . . . . .	6-2
A few words of caution . . . . .	6-3
Identify the cause of a problem . . . . .	6-3
TIC control answering an alarm . . . . .	6-4
TIC control problems . . . . .	6-5
TIC control alarm conditions . . . . .	6-7
PLC control answering alarms . . . . .	6-16
PLC control alarm conditions . . . . .	6-17
PLC control alarm errors . . . . .	6-20
PLC control alarm history screens . . . . .	6-21
PLC control alarm screen legend . . . . .	6-22
PLC control control problems . . . . .	6-23

PLC control alarm problems . . . . .	6-25
Checking and replacing switches . . . . .	6-37
Replacing the RTD. . . . .	6-38
Removing the pump components . . . . .	6-39
Replacing fuses. . . . .	6-40
Replacing the contractor . . . . .	6-41

## **A** Appendix

Customer service . . . . .	A-1
Maintenance log . . . . .	B-1
Pressure tables . . . . .	C-1
Overhead plumbing details . . . . .	D-1

# Introduction

---

Purpose of the user guide. . . . . 1-2

How the guide is organized. . . . . 1-2

Your responsibilities as a user. . . . . 1-3

ATTENTION:

    Read this so no one gets hurt . . . . . 1-4

# Purpose of the User Guide

This User Guide describes Conair's Portable Chillers and explains step-by-step how to install, operate, maintain and repair this equipment.



Before installing this product, please take a few moments to read the User Guide and review the diagrams and safety information in the instruction packet. You also should review manuals covering associated equipment in your system. This review won't take long, and it could save you valuable installation and operating time later.

# How the Guide is Organized

Symbols have been used to help organize the User Guide and call your attention to important information regarding safe installation and operation.



Symbols within triangles warn of conditions that could be hazardous to users or could damage equipment. Read and take precautions before proceeding.

- 1** Numbers indicate tasks or steps to be performed by the user.
- ◆ A diamond indicates the equipment's response to an action performed by the user.
- ☐ An open box marks items in a checklist.
- A circle marks items in a list.
-  Indicates a tip. A tip is used to provide you with a suggestion that will help you with the maintenance and the operation of this equipment.
-  Indicates a note. A note is used to provide additional information about the steps you are following throughout the manual.

# Your Responsibility as a User

You must be familiar with all safety procedures concerning installation, operation and maintenance of this equipment. Responsible safety procedures include:

- Thorough review of this User Guide, paying particular attention to hazard warnings, appendices, and related diagrams.
- Thorough review of the equipment itself, with careful attention to voltage sources, intended use, and warning labels.
- Thorough review of instruction manuals for associated equipment.
- Step-by-step adherence to instructions outlined in this User Guide.

# ATTENTION:

## Read this so no one gets hurt

We design equipment with the user's safety in mind. You can avoid the potential hazards identified on this machine by following the procedures outlined below and elsewhere in the User Guide.



**WARNING: Improper installation, operation, or servicing may result in equipment damage or personal injury.**

This equipment should be installed, adjusted, and serviced by qualified technical personnel who are familiar with the construction, operation, and potential hazards of this type of machine.

All wiring, disconnects, and fuses should be installed by qualified electrical technicians in accordance with electrical codes in your region. Always maintain a safe ground. Do not operate the equipment at power levels other than what is specified on the machine serial tag and data plate.



**WARNING: Electrical Hazard**

Before performing any work on this item, disconnect and lock out electrical power sources to prevent injury from unexpected energization or startup.



**CAUTION: Hot Surfaces**

Always protect yourself from hot surfaces when working on the Portable Chiller, especially when working on or around the compressor and condenser. These devices can reach up to 160°F {71°C}. Allow these devices to cool before performing any maintenance or troubleshooting.

**CAUTION: Ventilation hazard**

The unit requires a clean and well ventilated operating environment. Do not place anything on top of the unit while operating. Units with fans require unrestricted outlet air flow.

Water-cooled units require a minimum of one foot clearance around the perimeter for service-ability. Conair recommends two feet for ease of servicing. Air-cooled units require a minimum of two feet clearance around the perimeter for service-ability and proper air flow.

**WARNING: Hazardous substance**

When burned, Freon R22 refrigerant forms Phosgene gas. If the chiller is placed in the vicinity of equipment with combustible systems, the combustion air intake must be ducted in from the outside and sealed in such a manner as to prevent any refrigerant from entering the combustion chamber. Refer to the Material Safety Data Sheet for Freon R22 included in the appendix. This sheet explains the potential hazards and how to avoid them.



## Description

---

What is the Portable Chiller? . . . . .	2-2
Typical applications . . . . .	2-3
Limitations . . . . .	2-3
How it works: water-cooled	
portable chiller . . . . .	2-4
How it works: air-cooled portable chiller . . . . .	2-6
Portable chiller features . . . . .	2-8
Pump curves . . . . .	2-10

# What is the Portable Chiller?

The Conair Portable Chillers provide self-contained sources of chilled water and are available in either water- or air-cooled models with ranges from 1.5 Hp to 30 Hp (approximate capacities of 1.5 tons to 30 tons of refrigeration). Pump selections are available to match most process flow and pressure requirements.

The normal temperature range of discharge chilled water is 20°F to 65°F {7°C to 18°C}. For applications requiring 40°F and lower mix glycol with the water to the correct percentage.

Conair Portable Chillers are designed to provide chilled fluid for industrial applications requiring 24-hour-a-day performance. Units are totally self-contained for easy, economical installation. All parts wetted by the process are non-ferrous.

To operate, simply connect the power source, process piping and fill with water or with mix of water and industrial grade ethylene glycol or propylene glycol (but not automotive antifreeze).

These chillers are ideal for machine-side cooling to maintain process temperatures in an injection molding machine or extruder and wherever you need a small, moveable cooling unit. Nominal capacities range from 1.4 to 29.7 tons for the water-cooled models and 1.2 to 28.8 tons for the air-cooled models. Capacities are based on standard pump sizes and delivering 50°F {10°C} water.

Operation of these units differ only in the medium used to remove heat from the refrigerant in the condensers. Water-cooled models use 85°F {29°C} or lower cooling water from a tower, well, or city service; air-cooled models use 95°F {35°C} maximum ambient air; and high ambient models use 120°F {49°C} maximum ambient air (except for 15-ton high ambient model which uses 115°F {46°C} maximum ambient air).

Choose Water-cooled Portable Chillers where tower water or another inexpensive water source is available. Choose Air-cooled models for maximum portability of the unit or if a water source is unavailable.

Tube-in-tube or brazed plate condensers are standard equipment on all water-cooled models. Air-cooled models use copper-fin tube condensers.

All standard voltages are available.

# Typical Applications

The Conair Portable Chillers can be used anywhere a reliable source of process cooling water - with stable temperature control - is required.

These portable chillers are available for cooling injection molding, blow molding, thermoforming, extrusion, air compressors, metal plating, anodizing, degreasing, heatset/web offset printing presses, and dryer after-coolers.

Roll the air-cooled model next to the heat source, connect it, and plug it in. They can operate almost anywhere.

The water-cooled models require a source of condenser water. Normally used in conjunction with a recirculating evaporative cooling tower system, the units have slightly better operating energy efficiencies.

## Limitations

Conair Portable Chillers are designed to provide chilled water for industrial applications requiring 24-hour-a-day performance. Units are self-contained and easy to install and maintain. Choose the Conair Portable Chillers based on the cooling load and the capacity of the unit. Pick your Conair Portable Chillers based on:

- **Cooling load**

Choose a portable chiller that has 10% more capacity than the process load.

- **Location**

Choose a water-cooled model if the unit will be located in an air-conditioned area. Choose the water-cooled model if a source of condenser water is readily available (i.e. cooling tower water). The portable chiller is not designed for outdoor installation.

- **Temperature**

The portable chiller can provide a cooling temperature of 20°F to 65°F {7°C to 18°C}.

Use this information as a general guide. Consult your Conair representative for assistance when choosing a Conair Portable Chiller.

# How it Works: Water-cooled portable chillers

## Process circulation

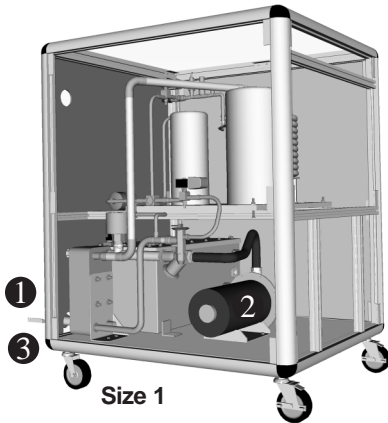

Size 1

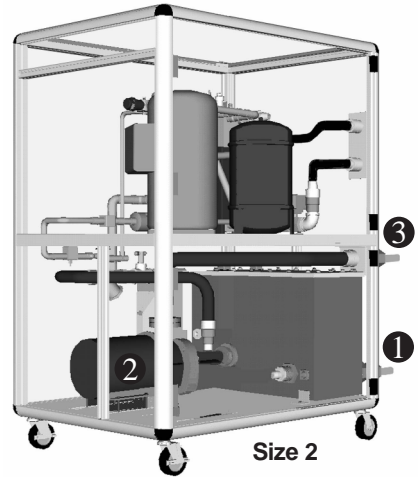

Size 2

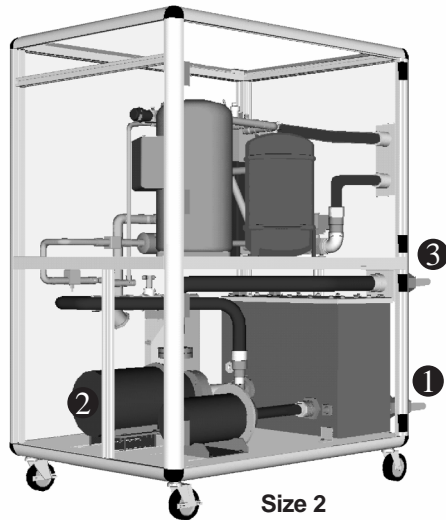

Size 2  
with recirculation pump  
(dual pump chiller)

- 1 Hot fluid from the process enters the chiller through the From Process connection into the pump reservoir.
- 2 Pump draws water from pump reservoir and moves it through the strainer and flow switch to the evaporator.
- 3 Fluid is chilled in the evaporator and exits through the To Process connection, returning to the process.



**NOTE:** A Dual pump chiller (size 2 with a recirculation pump) process pump pulls chilled water from the reservoir and pumps through the To Process connection returning to the process.

# How it Works: Water-cooled portable chillers

## Refrigerant circulation

- 1 The evaporator extracts heat from the process fluid, causing the refrigerant to vaporize (evaporate) into a gas.
- 2 Vaporized refrigerant travels from the evaporator to the compressor, where the low pressure vapor is compressed into a high-pressure, high-temperature vapor.
- 3 The high-pressure, high-temperature vapor from the compressor travels to the condenser.
- 4 The high pressure vapor travels from the condenser to the receiver. Water tower or city water removes heat from the vapor, condensing it to a high-pressure liquid.
- 5 High-pressure liquid is metered back to the evaporator by the expansion valve (TXV), changing it to a low-pressure, low-temperature liquid.

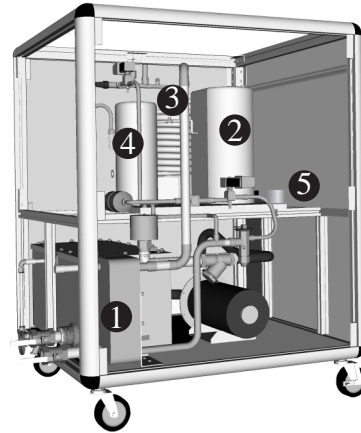

Size 1

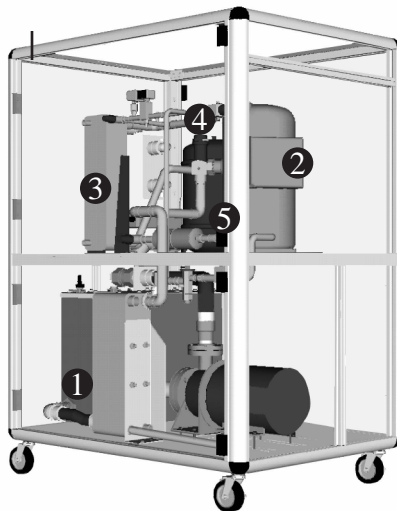

Size 2

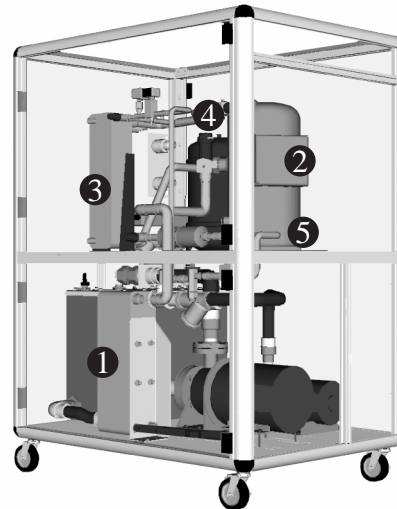

Size 2  
with recirculation pump  
(dual pump chiller)

# How it Works: Air-cooled portable chillers

## Process circulation

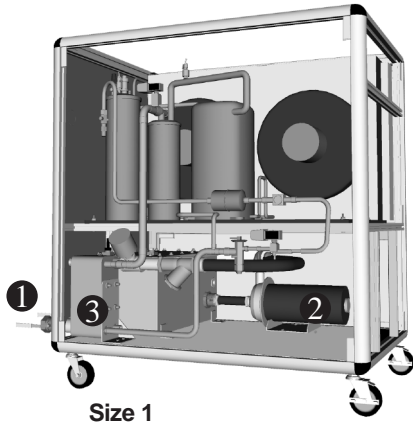

Size 1

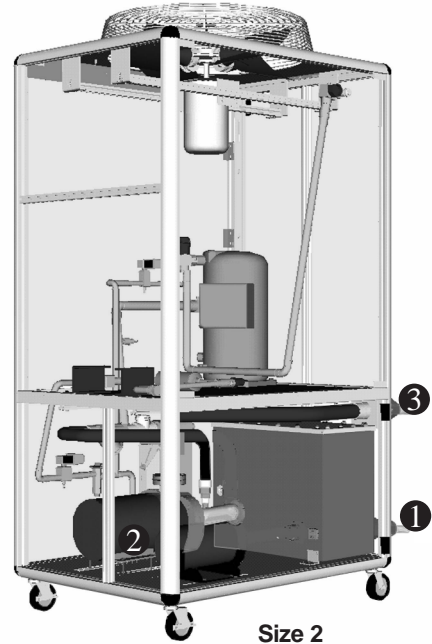

Size 2

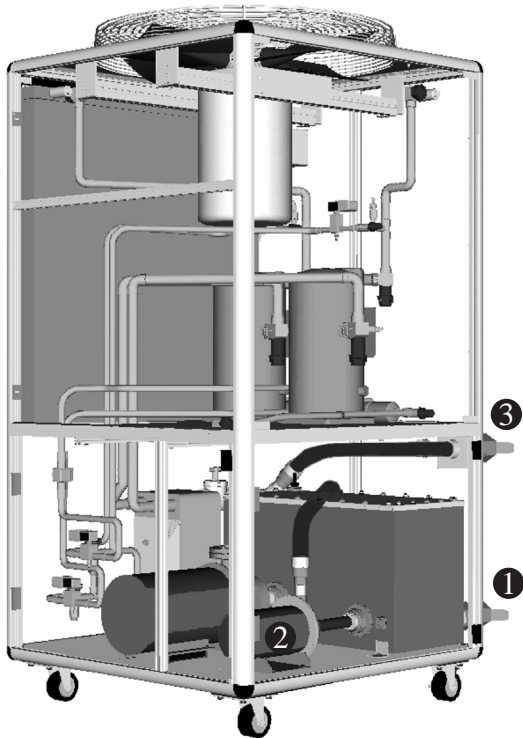

Size 2  
with recirculation pump (dual pump chiller)

- 1 Hot fluid from the process enters the chiller through the From Process connection into the pump reservoir.
- 2 Pump moves fluid from pump reservoir through evaporator where it is chilled.
- 3 Fluid is chilled in the evaporator and exits through the To Process connection, returning to the process.

**NOTE:** A dual pump chiller (size 2 with a recirculation pump) process pump pulls chilled water from the reservoir and pumps through the To Process connection returning to the process.

# How it Works: Air-cooled portable chillers

## Refrigerant circulation

- 1 The evaporator extracts heat from the process fluid, causing the refrigerant to vaporize (evaporate) into a gas.
- 2 Vaporized refrigerant travels to the compressor, where the low pressure vapor is compressed into a high-pressure, high-temperature vapor.
- 3 The high pressure vapor travels from the compressor through the condenser, where the fan cools and condenses the vapor into a high-temperature, high-pressure liquid.
- 4 High-pressure, high-temperature liquid is metered back to the evaporator by the expansion valve (TXV), changing it to a low-pressure, low-temperature liquid.



Size 1

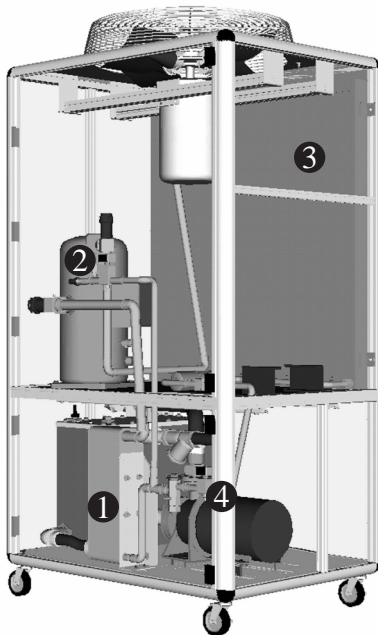

Size 2

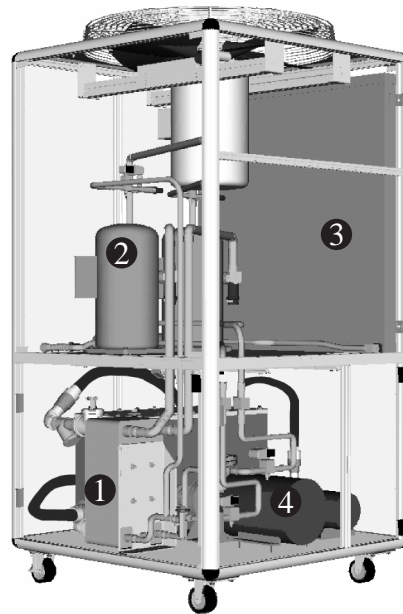

Size 2 with recirculation pump (dual pump chiller)

*Shown with one condenser removed for clarity.*

# Portable Chiller features

## Water-cooled models

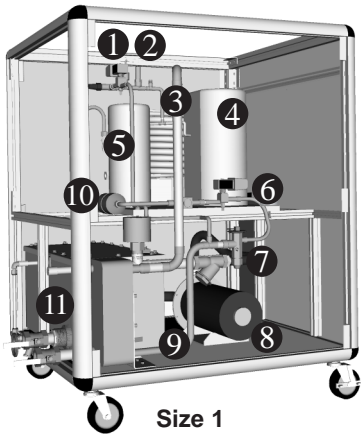

Size 1

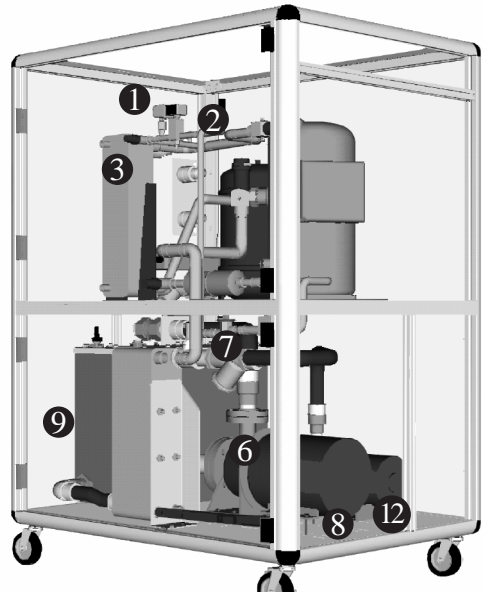

Size 2  
with recirculation pump  
(dual pump chiller)

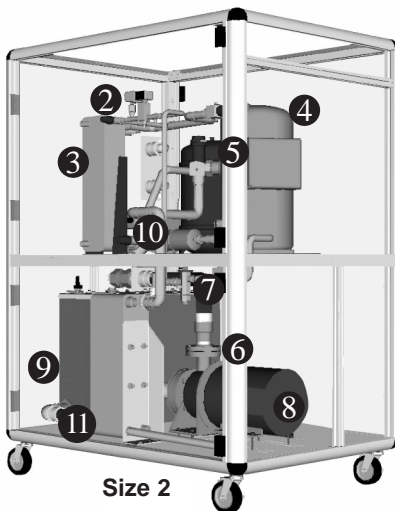

Size 2

- ① Hot Gas Bypass valve
- ② Relief valve
- ③ Condenser
- ④ Compressor
- ⑤ Receiver
- ⑥ Liquid line solenoid valve
- ⑦ TX valve
- ⑧ Process pump
- ⑨ Pump reservoir
- ⑩ Filter Dryer
- ⑪ Evaporator
- ⑫ Recirculation pump

# Portable Chiller features

## Air-cooled models

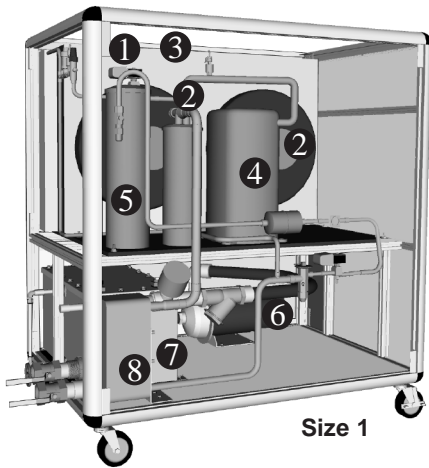

Size 1

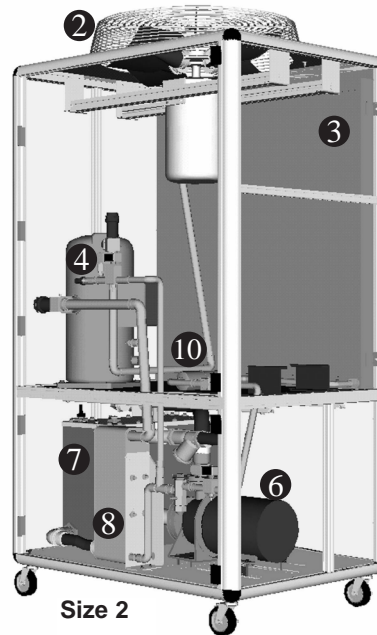

Size 2

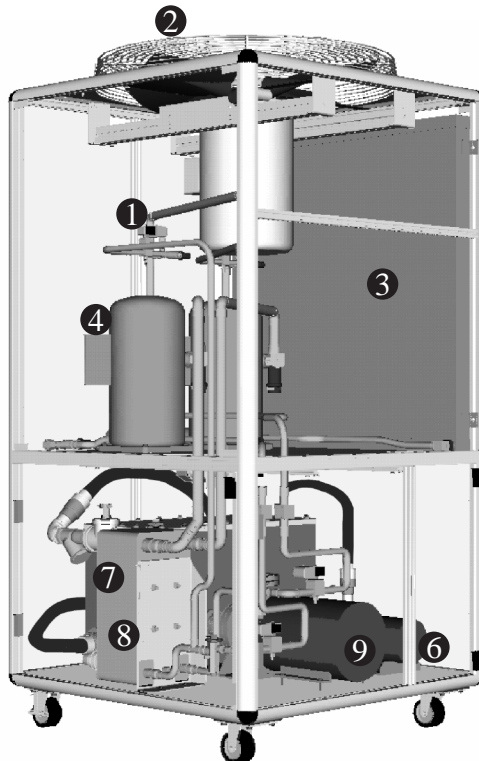

Size 2  
with recirculation pump  
(dual pump chiller)

- ① Hot Gas Bypass valve
- ② Fan
- ③ Condenser
- ④ Compressor
- ⑤ Receiver
- ⑥ Process pump
- ⑦ Pump reservoir
- ⑧ Evaporator
- ⑨ Recirculation pump
- ⑩ Filter Dryer
- ⑪ TX valve
- ⑫ Temperature sensor

# Pump curves

## SINGLE PUMP

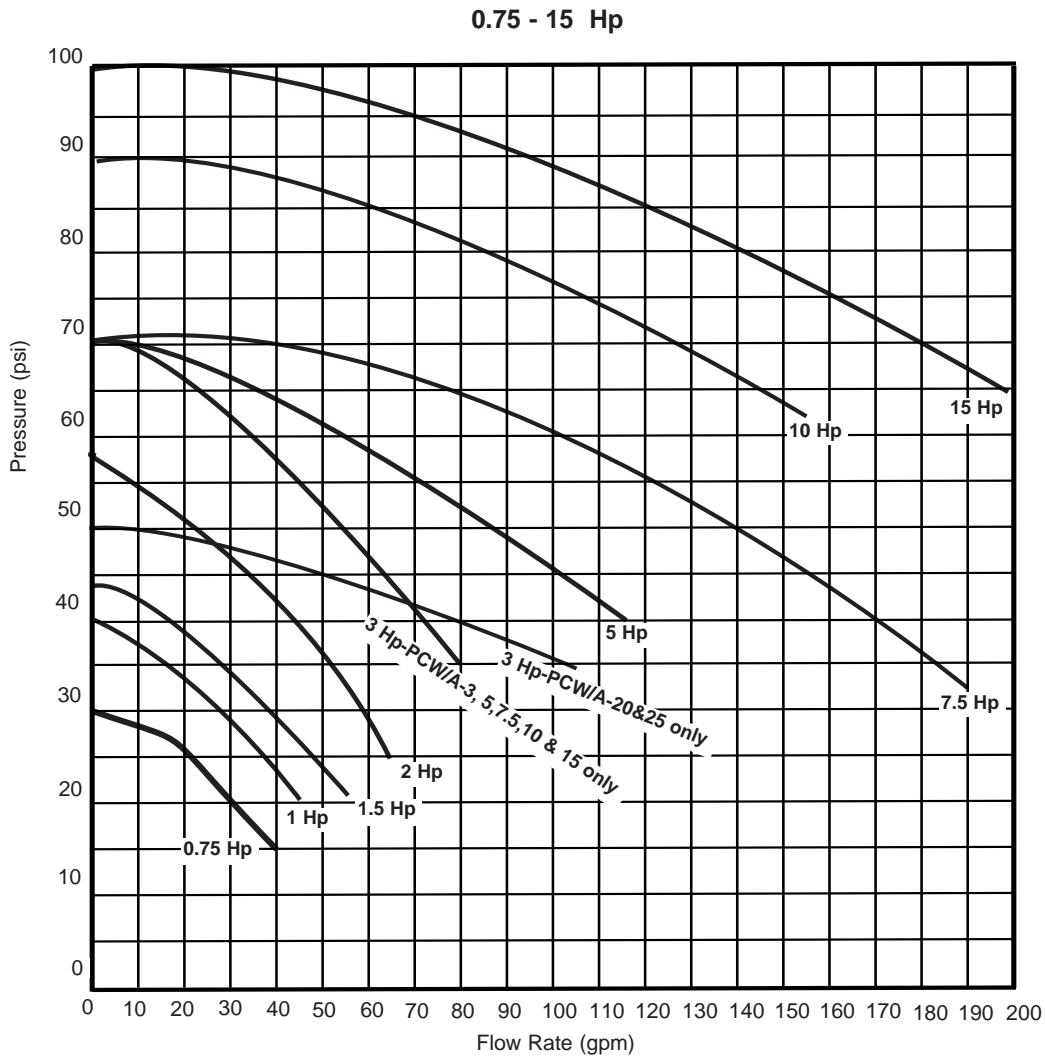

### SPECIFICATION NOTES:

\*These pump curves are non-overloading using the service factor of the motors.

Specifications may change without notice. Check with your Conair representative for the most current information.

# Pump curves

## DUAL PUMP

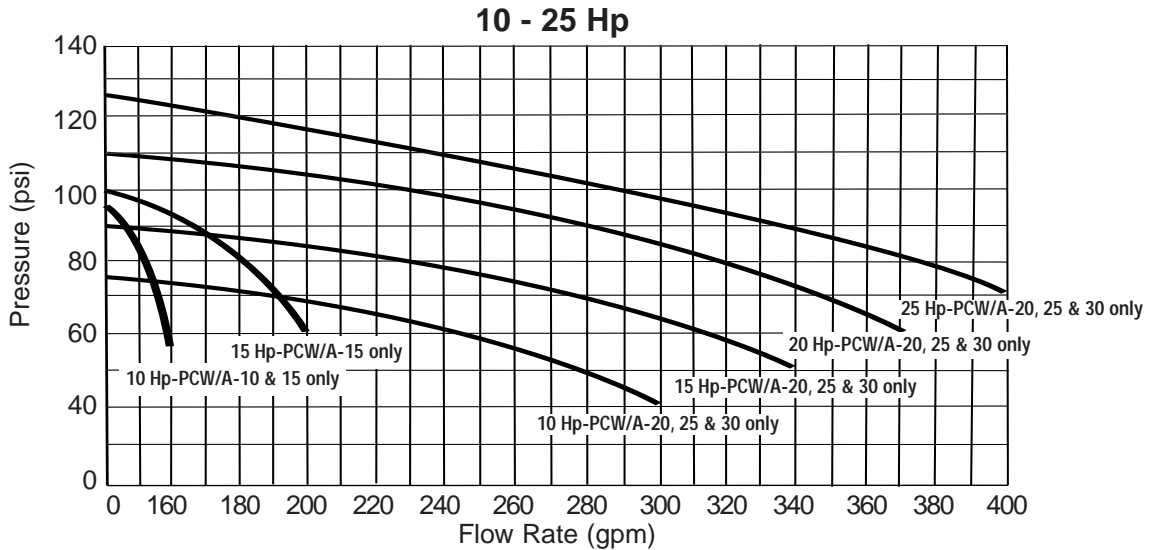
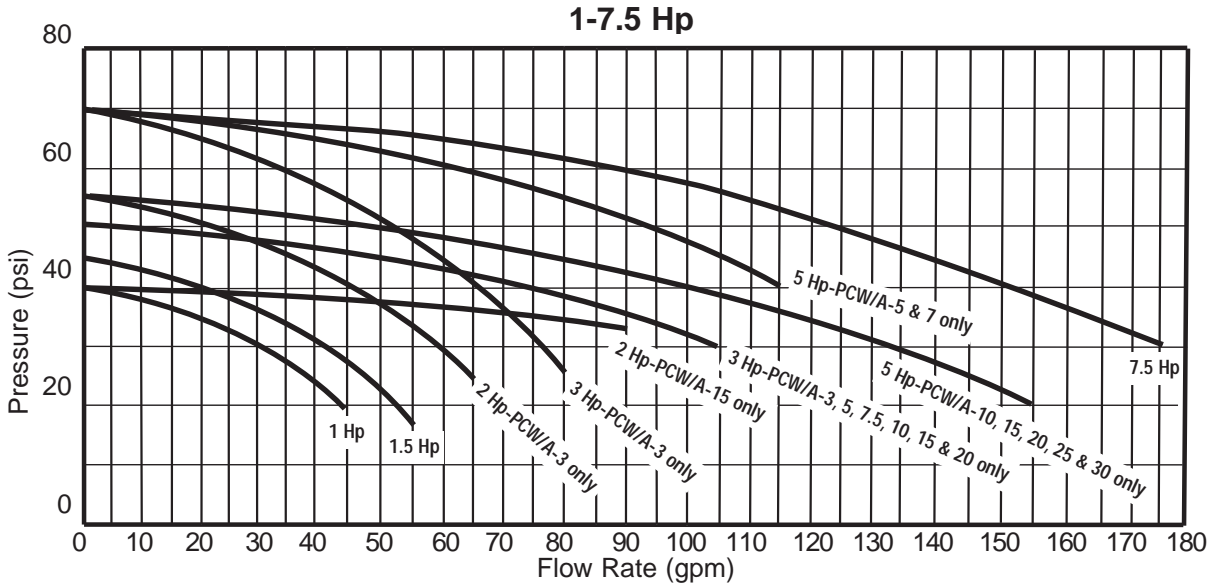

#### SPECIFICATION NOTES:

\*These pump curves are non-overloading using the service factor of the motors.

Specifications may change without notice. Check with your Conair representative for the most current information.



# Installation

---

Unpacking the boxes . . . . .	3-2
Warnings and cautions . . . . .	3-3
Preparing for installation . . . . .	3-4
Making process plumbing connections . . . . .	3-5
Filling the Chiller . . . . .	3-8
Checking the refrigerant charge . . . . .	3-10
Connecting the main power source . . . . .	3-11
Checking electrical connections . . . . .	3-12
<u>TIC CONTROL</u>	
Checking the pump rotation . . . . .	3-13
Checking the compressor . . . . .	3-13
Checking the water level gauge . . . . .	3-13
Initially warming the chiller . . . . .	3-14
<u>PLC CONTROL</u>	
Initially warming the chiller . . . . .	3-14
Checking pump rotation . . . . .	3-15
Checking for leaks . . . . .	3-16
Initially starting the chiller . . . . .	3-17
Stopping the chiller . . . . .	3-18

# Unpacking the Boxes

The portable chiller comes fully assembled in a single crate. Some air-cooled units are shipped without the casters attached. The casters must be attached during unpacking.



## **CAUTION: Lifting**

Conair Portable Chillers are designed to easily roll on casters. If, for some reason you need to lift the chiller, take all precautions to avoid personal injury or damage to the chiller. Lift the chiller using a forklift or hoist with straps that have been positioned at the chillers' center of gravity. Do not try to lift the unit manually.

- 1 Carefully uncrate the chiller and its components**
- 2 Remove all packing material, protective paper, tape, and plastic.** Compare contents to the shipping papers to ensure that you have all the parts.
- 3 Carefully inspect all components to make sure** no damage occurred during shipping. If any damage is found, notify the shipping agent immediately to file a claim. Check all wire terminal connections, bolts, and any other electrical connections, which may have come loose during shipping. Check for pinched wires and kinked hoses.
- 4 Cut the bands holding the chiller on the pallet.**
- 5 With a forklift lift the chiller high enough to attach** the casters, if shipped unattached. Thread the casters into the threaded plates on each corner of the unit.
- 6 Record serial numbers and specifications** for the chiller in the blanks provided on the back of the User Guide's title page. This information will be helpful if you ever need service or parts.

## Warnings and Cautions



**WARNING: Improper installation, operation, or servicing may result in equipment damage or personal injury.**

This equipment should only be installed, adjusted, and serviced by qualified technical personnel who are familiar with the construction, operation, and potential hazards of this type of machine.

All wiring, disconnects and fuses should be installed by qualified electrical technicians in accordance with electrical codes in your region. Always maintain a safe ground. Do not operate the equipment at power levels other than what is specified on the machine data plate.



**CAUTION: Hot Surfaces**

Always protect yourself from hot surfaces when working on the Portable chiller, especially when working on or around the compressor and condenser. These devices can reach up to 160°F (71°C). Allow these devices to cool before performing any maintenance or troubleshooting.



**CAUTION: Ventilation**

The unit requires a clean and well ventilated operating environment. Do not place anything on top of the unit while operating.

Units require enough clearance around the perimeter for access doors to open completely. Air-cooled units require a minimum of two feet clearance around the perimeter for proper air flow.



**WARNING: Refrigerant hazard**

Only certified refrigerant technicians should examine and correct problems involving the refrigerant circuit.



**WARNING: Hazardous substance**

When burned, Freon R22 refrigerant forms Phosgene gas. If the chiller is placed in the vicinity of equipment with combustible systems, the combustion air intake must be ducted in from the outside and sealed in such a manner as to prevent any refrigerant from entering the combustion chamber. Refer to the Material Data Sheet for Freon R22. This sheet explains the potential hazards and how to avoid them.

# Preparing for Installation

Plan the location for the chiller and prepare the area properly.

Position the chiller as close to the process machine as possible. Place the chiller in position near the process machine so that fluid lines can be connected from the process machine to the chiller and back.

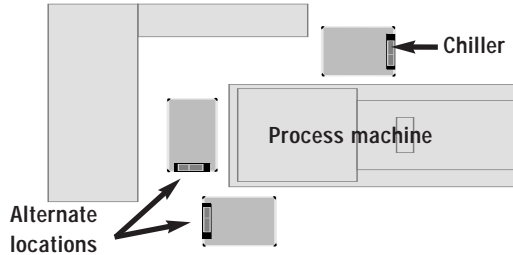

**Make sure the area where the chiller is installed has:**

**A grounded power source.**

Check the chiller's serial tag for the correct amps, voltage, phase, and cycle. All wiring should be completed by qualified personnel and comply with your region's electrical codes.

**Clearance for safe operation and maintenance.**

Make sure there is two feet clearance around the chiller for proper operation. After positioning lock casters to prevent chiller from moving. For maintenance and servicing, be sure there is enough clearance to remove all access panels completely.

**NOTE:** Air-cooled models must be positioned so that the condenser air inlet is no warmer than 95°F (35°C) and the condenser air outlet is not blocked or restricted in any way. Refer to high ambient models if higher than 95°F (35°C).

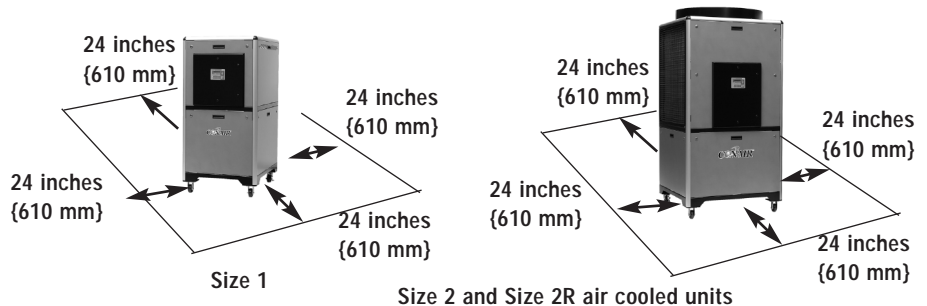

**Available water source.**

If installing a water-cooled unit, make sure water source is plumbed to chiller installation location. High points in plumbing require vent valves; low points require drain valves.

# Making Process Plumbing Connections

Warm fluid from process equipment enters the chiller at the From Process connection and chilled fluid returns to the process equipment through the To Process connection.

- 1 Remove the shipping plastic pipe plug from the female connections on the back of the portable chiller.**
- 2 Make sure the male pipe threads are clean and new.**
- 3 Wrap threads with Teflon or pipe dope.**
- 4 Connect the From Process valve (factory optional) on the back of the chiller to the From Process tubing.** Start by hand until the threads engage and then tighten with a pipe wrench. Tighten only enough to prevent leaks; do not over-tighten.
- 5 Connect the To Process valve (factory optional) on the back of the chiller to the return tubing.** Start by hand until the threads engage and then tighten with a pipe wrench. Tighten only enough to prevent leaks; do not over-tighten.

# Making Process Plumbing Connections (continued)

For the Water-cooled Chillers connect the water source for cooling to the Condenser Water inlet on the back of the chiller. Connect the Condenser Water outlet for returning water.

## Size 1 Cabinet Water Cooled

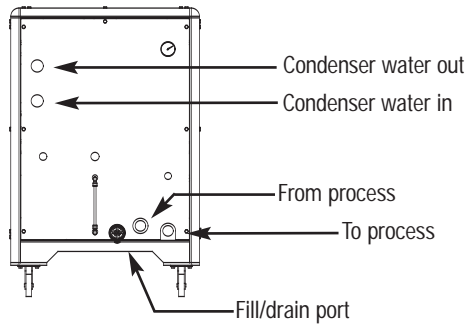

## Size 2 Cabinet Water Cooled

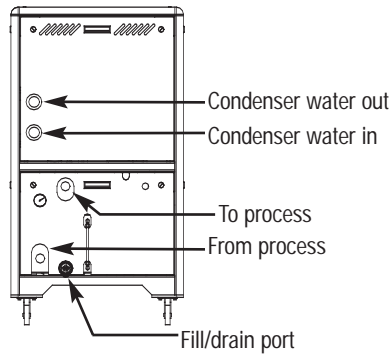

# Making Process Plumbing Connections (continued)

Size 1 Cabinet Air Cooled

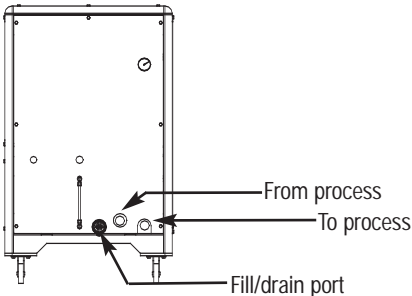

Size 2 Cabinet Air Cooled

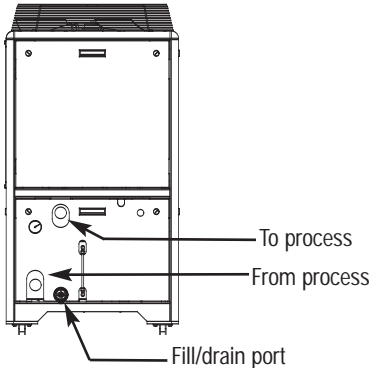

For overhead piping installations, see *Overhead Plumbing Details*, in the Appendix.

# Filling the Chiller

The chiller is shipped without coolant. The chiller is filled manually during installation. Use water as the coolant down to 40°F {4°C}. Below 40°F and down to 20°F {-7°C}, use an ethylene glycol or propylene glycol and water solution (see Percent Glycol vs. Temperature chart).

To fill with water:

- 1 Attach water supply to Fill/Drain valve or the auto-fill port.**
- 2 Close the To Process and From Process valves. (Factory Optional)**
- 3 Open the Fill/Drain valve or water supply (auto-fill option) and fill chiller to the fill mark on the Water Level gauge.** If the chiller is overfilled, the excess water spills out the vent tube. **DO NOT OVERFILL.**
- 4 Close the Fill/Drain valve.**
- 5 Check the coolant level.** When the chiller is turned on the coolant level drops as the coolant begins to circulate, filling the connected plumbing. Check the coolant level on the back of the chiller. The coolant level shows on the water level gauge. Make sure coolant level is filled to the mark on the gauge. Add more if needed.
- 6 Disconnect water hose from Fill/Drain valve.**

 **NOTE:** If your chiller has the optional auto-fill reservoir, the level switch will automatically fill the reservoir with water as needed.

 **NOTE:** The optional To and From Process valve locations may vary their locations depending on the model. See the labels on the unit or refer to pages 3-6 and 3-7.

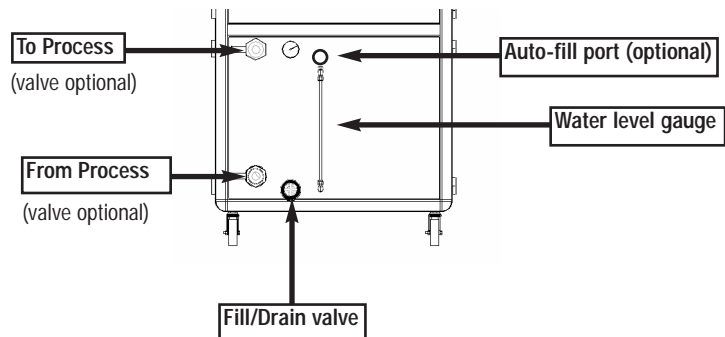

# Filling the Chiller (continued)

To fill with glycol solution:

- 1 Mix the glycol to the proper percentage.** Use the table to determine the percentage (by volume) of glycol needed for the process temperature (in °F) you require. Mix the proper percentage of glycol with water.

Recommended Percentages of Glycol for Chilled Water Freeze Protection		
Discharge water Temperature	% Propylene Glycol	% Ethylene Glycol
Above 45°F	0	0
40°F	20	15
35°F	25	20
30°F	35	30
25°F	40	35
20°F	45	40
Below 20°F	Consult Factory	

- 2 Close the To Process and From Process valves. (Factory Optional)**
- 3 Open the Fill/Drain valve and fill chiller to approximately 3/4 full or the fill mark on the Water Level gauge.** If the chiller is overfilled, the excess fluid spills out the vent tube. **DO NOT OVERFILL.**
- 4 Close the Fill/Drain valve.**
- 5 Check the coolant level.** The coolant level drops as the coolant begins to circulate and fill the connected plumbing. Check the coolant level on the back of the chiller. The coolant level shows on the water level gauge. Make sure coolant level is filled to the mark on the gauge. Add more if needed.
- 6 (For the optional PLC control only) Set the Chiller control for ‘Percent Glycol’.** Set the percent glycol using the PLC control (see Setting Percent Glycol, section 4). Do this step after main power is connected to the chiller and initial startup has already been performed.

# Checking the Refrigerant Charge

All chillers are fully charged with refrigerant at the factory. Your chiller's model nameplate identifies the type and amount of total refrigerant charge required.

Check refrigerant charge while the chiller is running. Check the refrigerant charge through the sight glass. For water-cooled models open the side panel for a short period of time (15 seconds maximum) and check the sight glass; for air-cooled models, locate the sight glass through the wire mesh side panel (size 1). Use a flashlight, if necessary, and check the sight glass:

☐ **Under full load conditions**, the refrigerant should be clear (no bubbles).

☐ **Under low load conditions**, when the hot-gas bypass valves are operating, bubbles may be visible in the sight glass. This is normal.

 **NOTE:** Leaving the air-cooled side panels off for an extended period of time will reduce performance.

If the charge is low and the unit is under warranty, contact Conair service. Otherwise have a local, certified refrigeration technician add refrigerant to the system.



## **WARNING: Refrigerant hazard**

Only certified refrigerant technicians should examine and correct problems involving the refrigerant circuit.



## **WARNING: Hazardous substance**

When burned, Freon R22 refrigerant forms Phosgene gas. If the chiller is placed in the vicinity of equipment with combustible systems, the combustion air intake must be ducted in from the outside and sealed in such a manner as to prevent any refrigerant from entering the combustion chamber. Refer to the Material Data Sheet for Freon R22. This sheet explains the potential hazards and how to avoid them.

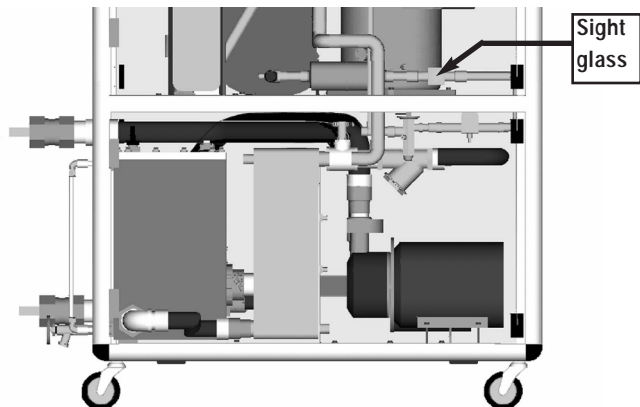

# Connecting the Main Power Source

**⚠️ WARNING: Improper installation, operation, or servicing may result in equipment damage or personal injury.**

This equipment should only be installed, adjusted, and serviced by qualified technical personnel who are familiar with the construction, operation, and potential hazards of this type of machine.

All wiring, disconnects and fuses should be installed by qualified electrical technicians in accordance with electrical codes in your region. Always maintain a safe ground. Do not operate the equipment at power levels other than what is specified on the machine data plate.

**⚠️ WARNING: Electrical hazard**

Before performing any work on this item, disconnect and lock out electrical power sources to prevent injury from unexpected energization or startup.

**1 Open the chiller’s electrical enclosure.\***

**2 Connect the power wires to the terminals.**

(See the wiring diagrams that came with your machine). Route the power cable through the hole in the side of the chiller to the electrical enclosure.

**3 Check terminal screws to make sure wires are secure.**

Gently tug each wire, if wire is loose, use a screwdriver to tighten the terminal.

**4 Connect the ground wire to the grounding lug.**

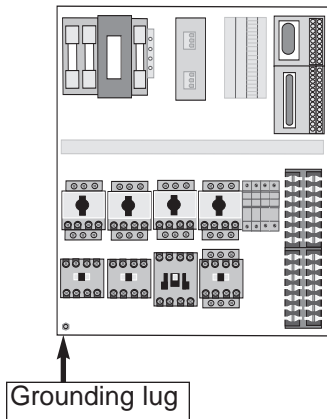

\* Overload modules on UL panel only.

# Checking Electrical Connections

## **WARNING: Electrical Hazard**

Before performing any work on this item, disconnect and lock out electrical power sources to prevent injury from unexpected energization or startup.

### **1 Open electrical enclosure.\***

- 2 Check the short-to-ground with an ohm meter.** Connect the ohm meter to each of the three terminal screws and to the grounding lug. Test all three for resistance. The minimum resistance to ground should be 1 megohm. If it resistance is less that 1 megohm there is a leak in the system.

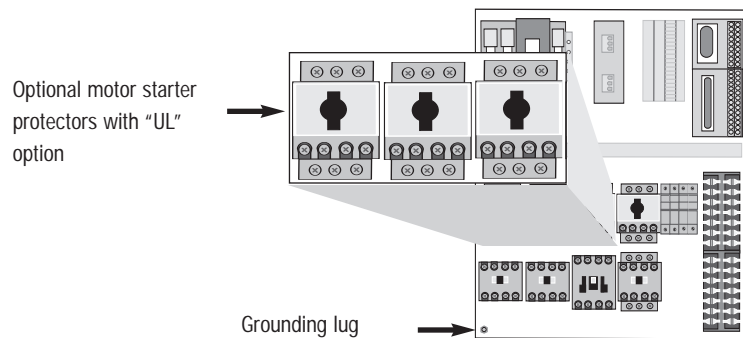

- 3 Close the electrical enclosure.** The chiller is now ready for initial startup. Follow the rest of the installation steps for the control you have (TIC or PLC).

*\* Overload modules on UL panel only.*

## TIC Control Checking Pump Rotation

Press the on/off and enter buttons simultaneously to turn on Pump. Press the on/off and enter buttons simultaneously to turn off pump.



Check the rotation of the pump. Compare pump rotation to arrow direction on pump. If pump is not turning in proper direction, disconnect main power to chiller, swap any two incoming power wires; reapply main power. Check for leaks inside the chiller cabinet; fix any leaks and dry the inside of the chiller before proceeding.

If alarm light comes on check the alarm description and follow troubleshooting guide for repair.

## TIC Control Checking the Scroll Compressor Only Models PCW 7.5, 10, and 15 and PCA 7.5, 10 and 13

Compressor rotation only needs to be checked if using a 7.5 ton unit or higher. Pump rotation if done correctly by reversing leads at the incoming power will provide proper rotation for the rest of the three phase motors. You will not be able to see compressor rotation unless you have refrigeration gauges.

Inspect the compressor. If the compressor is wired incorrectly, the compressor LED will light but compressor will not run. Disconnect the Chiller from the main power supply, switch any two incoming main power leads, and reapply main power supply. Wait three minutes. The compressor should now be running in the proper direction.

## TIC Control Checking the Water Level Gauge

Check the water level gauge on the back of the chiller. If the fluid level is low, follow the steps to add fluid. See *Filling the Chiller*, section 3.

 **NOTE:** If correct pump rotation was established, the compressor rotation will be correct. Both the pump and compressor are phased together during manufacture.

# PLC Control Initially Warming the Chiller

## **WARNING: Initial startup**

Do not press any buttons after initially applying power to the chiller. Let the chiller set, undisturbed, for a minimum of 8 hours before starting the chiller. This is necessary to allow the crank case heater to warm properly, and to prevent the refrigerant from pooling in the compressor.

- 1 Turn on main power source.** The control boots up and when finished, the screen displays “Press enter to continue.”
- 2 Press enter.** This screen will appear.

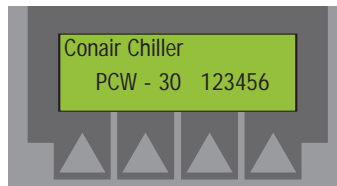

- 3 Press next.** The screen displays information about the chiller, which includes the model, series, size, and serial number. The menu options are listed on the bottom of the screen (“Stat Setup Run Alarm”). The “Select Option” key button located under each of the menu options is used to navigate to the corresponding menu option. Record the data from this screen in the front of your manual. You will need this information for any parts or service related question. (*See page 4-17 to understand your model number.*)

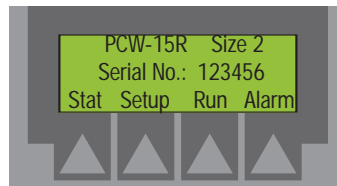

- 4 Pump, compressor and alarm indicator lamps will flash three times.** The compressor lamp will flash an additional three minutes.

# PLC Control Checking the Pump Rotation

After the initial warm up, check for proper pump rotation. If the pump rotation is correct, all other 3-phase components will be in the proper rotation and do not need to be checked.

Manually turn on the pump from the main screen:

**1 Press the arrow pointing to Run on the screen.** →

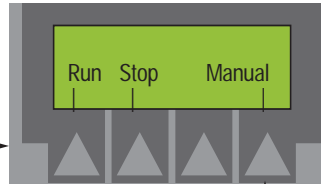

**2 Use the Scroll arrows to scroll through Run screens to the Manual Pump screen.**

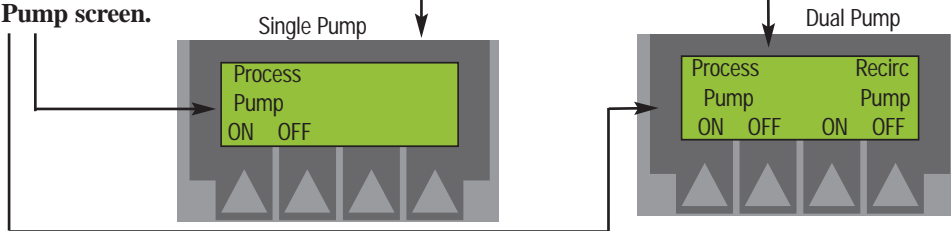

**3 Press the ON arrow.** The pump should begin running. Open the chiller cabinet and check the rotation of the pump. The pump should be turning clockwise. If the pump is not turning or is turning counterclockwise, press the Stop Chiller button, disconnect the main power to the chiller and swap any two main incoming wires. Reapply main power to the unit, scroll to the Manual pump screen and again turn on the pump. Pump should now be turning clockwise. If an alarm occurs, see Answering Alarms, in the Troubleshooting section. If alarm continues or reoccurs, call your Conair Service representative.

**4 Press the Escape/Previous Screen button 2 times,** or if following the sequence of this manual continue with the instructions on the next page. The control returns to the main screen.



# PLC Control Checking for Leaks

After checking pump rotation, continue with startup by checking the chiller for leaks. Do this by turning on only the pump from the control and letting the pump run while checking the inside of the chiller.

- 1 Press the Next arrow on the control to move to the Main screen.



The Main screen displays:

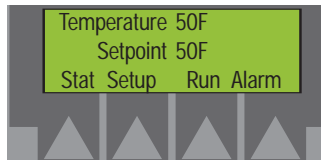

- 2 Press the Run arrow on the screen.

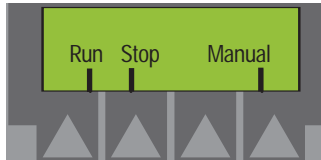

- 3 Press the Scroll arrows to scroll to the Manual Pump screen. The Manual Pump screen displays:

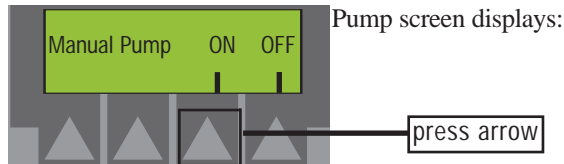

- 4 Press the Process Pump ON arrow. If you have the optional recirculation pump, turn it on. With the pump running check the inside and outside plumbing of the chiller for leaks.

If you find leaks:

- 1 Press the Process Pump OFF button on the control panel.



- 2 Disconnect and lock out the main power supply to the Chiller. Repair any leaks. Dry any moisture inside the chiller.

- 3 Reconnect the main power supply.

- 4 Repeat steps 1-4.

# PLC Control Initially Starting the Chiller

Only after you have checked for leaks and checked for pump rotation should you start the chiller. To initially start the chiller, from the main screen:

## 1 Press the Run arrow.

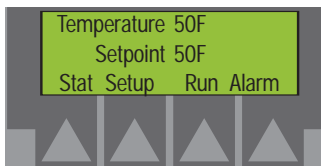

The Run screen displays:

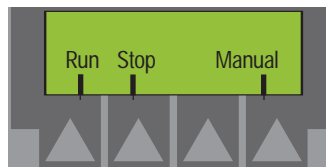

- 2 Press the Pump(s) arrow.** Verify that the pump begins to run, followed by the compressor if process temperature is above setpoint. Check that the Compressor light and the Process Pump light on the control panel are lit.
- 3 If you get an alarm message on the display; Press STOP and see troubleshooting or previous setup pages.** If you get a message, press the Stop Chiller button, unplug chiller from main power supply, switch any two incoming main power leads, and apply main power supply. Wait for the required warmup time and then press Run arrow.
- 4 Press the Escape/Previous button to return to the Main Screen.**



**NOTE:** If you have the dual pump option the process pump will not start if the evaporator out temperature is above 75°F (23.9°C).

# Stopping the PLC Chiller

To stop the chiller, press the Stop button on the control panel.

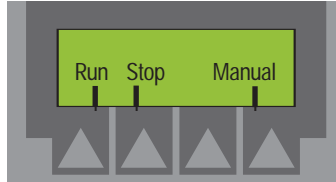

The compressor shuts off after a pumpdown and the pump shuts off 10 seconds later. This allows the chiller to pump down the refrigerant system and store the refrigerant in the receiver (water-cooled models) or condenser (air-cooled models). This prolongs the life of the compressor.

 **NOTE:** If you try to restart the chiller immediately after stopping it, pressing the Run arrow on the display starts the pump (the Process Pump light on the control panel lights) but the compressor will not turn on for three minutes. After three minutes the compressor turns on and the Compressor light on the control panel lights. This allows the Compressor's internal temperatures to lower, making restart easier, and prolonging the life of the compressor.

If the chiller is not working properly at any time, stop the chiller and refer to the Troubleshooting section. If you do not encounter any problems, proceed to the Operation section.

 **IMPORTANT:** In the event the chiller needs to be stopped immediately, press the red chiller Stop button on the control panel.

# Operation

---

TIC control features . . . . .	4-2
PLC control features . . . . .	4-3
Before starting . . . . .	4-4
<u>TIC CONTROL</u>	
Control features . . . . .	4-5
Changing the setpoint temperature. . . . .	4-6
Stopping/starting the chiller . . . . .	4-7
Menu features . . . . .	4-8
Changing the settings . . . . .	4-8
Tuning the chiller . . . . .	4-9
<u>PLC CONTROL</u>	
Powering up . . . . .	4-16
Setup menu . . . . .	4-17
Running/stopping the chiller . . . . .	4-18
Viewing chiller run menu . . . . .	4-18
Changing setpoint temperature . . . . .	4-21
Changing high temperature deviation . . . . .	4-22
Setting percent glycol . . . . .	4-23
Selecting the temperature scale. . . . .	4-25
Resetting PID settings . . . . .	4-26
Setting fan setpoints . . . . .	4-27
Setting discharge pressure setpoint . . . . .	4-29
Selecting PID values . . . . .	4-30
Manually starting/stopping the pump . . . . .	4-31

# TIC Control Features

The TIC control lets you view the status of the chiller and change settings.

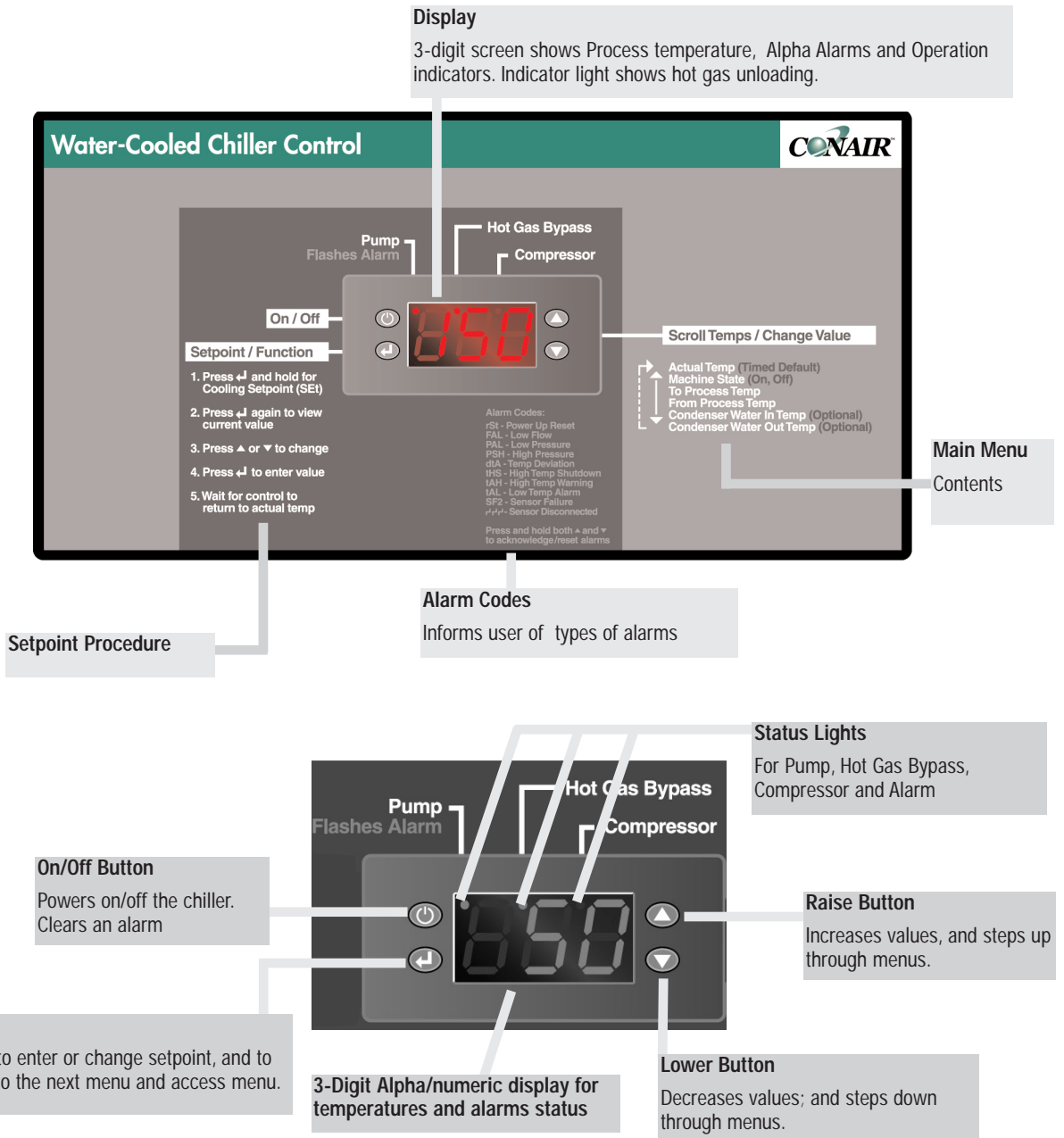

# PLC Control Features

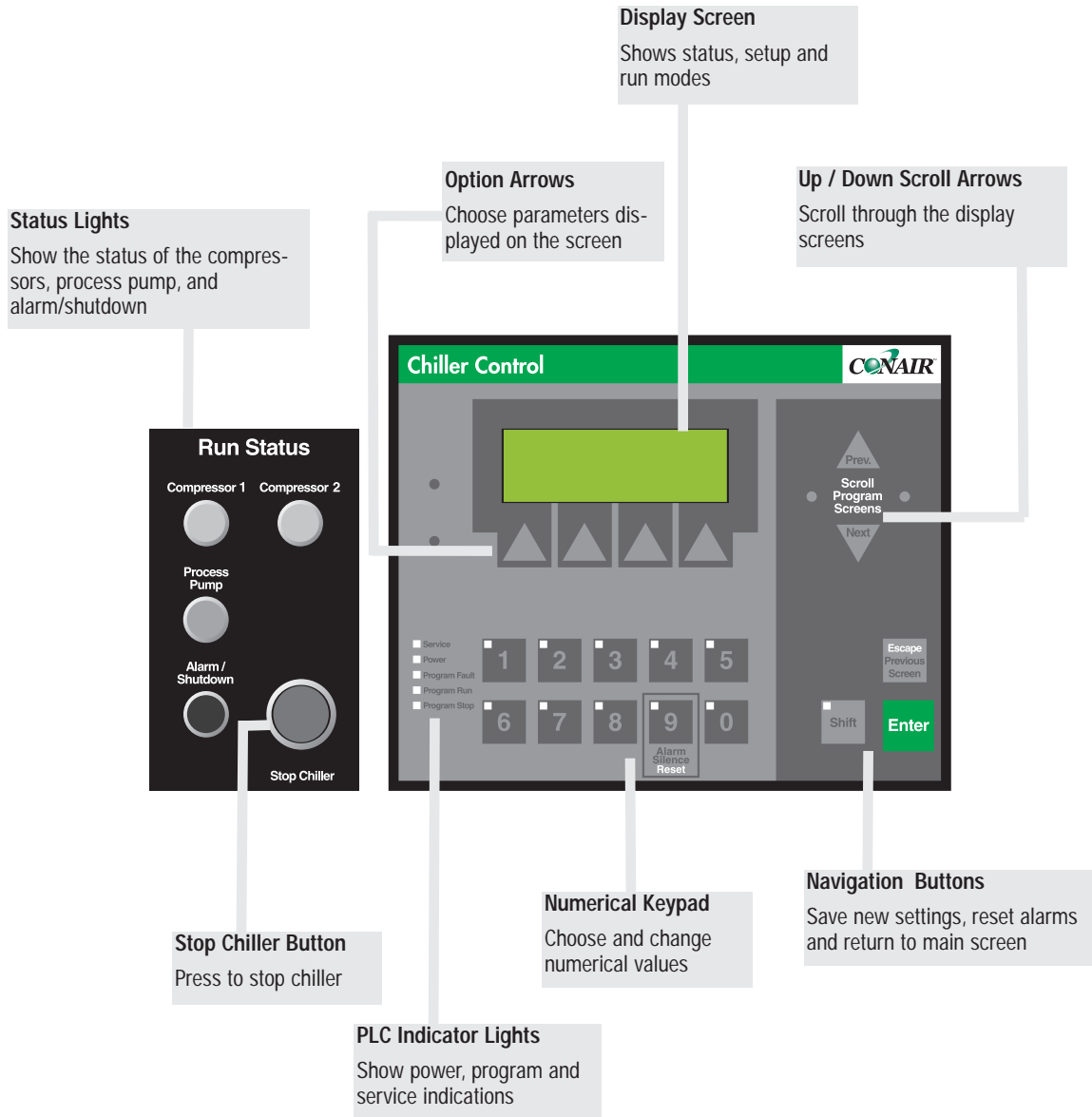

# Before Starting

Before you start daily operation of the chiller, you need to perform scheduled preventative maintenance. Necessary maintenance is described in the Maintenance section of this Users Guide.



## **WARNING: Electrical Hazard**

Before performing any work on this item, disconnect and lock out electrical power sources to prevent injury from unexpected energization or startup.



**NOTE:** The daily, weekly, monthly, and annual maintenance procedures are detailed in the Maintenance section. Go there for the detailed maintenance descriptions.

Daily maintenance includes:

- **Checking electrical connections**
- **Checking process fluid level in the pump tank**
- **Checking the condenser coil for debris (air-cooled only)**
- **Verifying pump discharge pressure**
- **Inspecting piping for leaks**

Before starting the chiller be sure to:

- **Open the From Process valve** (Factory Optional) to the full open position.
- **Open the To Process valve** (Factory Optional) to the 3/4 open position. You will need to adjust this valve when the chiller is running to obtain the desired pump discharge pressure. To find the approximate water flow, refer to the Pump Curves in Description section.
- **Open the supply valve** if the chiller has the optional Auto-fill reservoir.

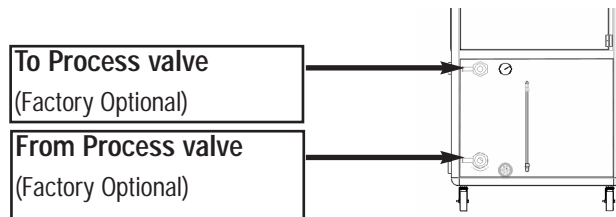

If you have purchased a chiller with optional process valves with bypass:

- 1 Close To Process valve.**
- 2 Open bypass valve.**
- 3 Start pump and close by-pass slowly until Flow Fault is displayed.**
- 4 Reset alarm and open by-pass slightly then restart pump.**
- 5 Adjust by-pass open slightly in the event Flow Fault reoccurs.**

You are ready to use your Chiller. Proceed to the steps for your type of control: TIC or PLC.

# General TIC Control Features

## Menus on the Controller:

The controller has information available in 5 areas. Four of them are user accessible. These are: the Main Menu, the Setpoint Menu, the Configuration menu and the Alarm Page. The service page also has additional parameters that are accessible in cases of need.

## Relaying Control information via three modes:

The controller relays information via three modes.

- 1 The status lights indicate the state of the machine and its control components. In the chiller these are Pump, Hot gas valve, and Compressor.
- 2 The digital indication of the process in temperatures and times.
- 3 The alpha abbreviation of the process parameters to isolate the variables and the alarms from each other.

## Main Menu

The main menu is the normal operating page. The controller always defaults to this page after a certain amount of inactivity (buttons being pushed). The first screen is the process variable. This is a user selectable parameter and could be the to process, from process or an average temperature. The rest of the variables are accessed in a circular queue using only the up and down arrow keys.

## The parameters include:

**Process Variable**- in the units selected on the Configuration page. This parameter has its decimal fixed to whole numbers only.

**Machine State** - For the Chiller this is on/off.

**The To Process temperature** - in units selected as above. This parameter has its decimal fixed at 0.1°

**The From Process temperature** - in units selected above. This parameter has its decimal fixed at 0.1°

There are two additional temperature indicators available for the chiller and must be purchased separately. If installed they will indicate only the temperature of the media to which they are exposed. These were intended to display condensing media temperature to the chiller operator however they could display any temperature in the operating range of 0-250°F. These temperature displays are also shown as whole numbers. If these are not connected; is displayed.



# Resetting the TIC Control and Power Up

When powered, the chiller control automatically performs a bootup routine. When the bootup routine is complete, the display will alternate between “rst” and the actual to process temperature. To reset the control on power up, press the up and down arrow keys simultaneously for 1 second. This will reset the control and return it to the operating mode it was in before the power was disconnected, this may have been running mode. If so and the chiller must be stopped, immediately press the stop/start button after resetting the control. The chiller is now ready to accept a setpoint and begin operation.

## TIC Control Features Changing the Setpoint (SET)

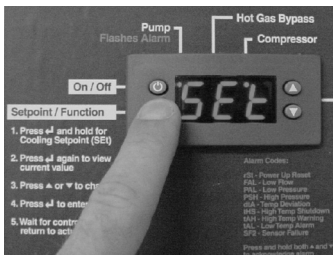

To return to the To Temperature screen from any other screen, you must wait (do not push buttons during this time) for the control to time out to home page “process temp”

### Setpoint

The Setpoint menu only has one parameter, which is the setpoint. This setpoint temperature is the water temperature that is required to be supplied by the chiller. The setpoint range of the chiller is 20°F - 65°F, however the standard settings will only allow the operator to set as low as 45°F. If a temperature lower than 45°F is required the low setpoint limit (LTS) and the low setpoint alarm (SPL) must be adjusted accordingly. These parameters are discussed in later pages. Additionally, an industrial Glycol will need to be added to chilled water solution to prevent freezing. See Chart in Filling the Chiller, Section 3.

### To set the temperature setpoint:

**1 Press the Enter button until “SEt” is displayed.**

**2 Press Enter again to display value of Setpoint,**



**3 To raise and lower the setpoint temperature.** Each time you press the arrow the temperature changes one unit. Stop when you reach the temperature you want. This value is in the units chosen °F or °C. See Changing Units, Section 4.



**4 Press the Enter button,** to accept the new setpoint temperature. The display returns to the actual process temperature. If the Enter button is not pressed the change in setpoint is not retained and any changes required must be reentered and confirmed.



# Starting/Stopping the Chiller

## Press the Stop/Start Chiller button.

Check the Pump and Compressor lights on the control panel; they should turn on and off as the pump and compressor cycle on and off. The To Process temperature displays on the control, and is the real-time temperature. It should change as the chiller runs and cools the fluid. This is what the chiller controls.

To safely stop the chiller at any time, press the Stop/Start Chiller button on the control panel. The compressor should stop immediately but the pump runs for 2.5 seconds.

The chiller remains on, but stopped. The display screen on the control remains on.

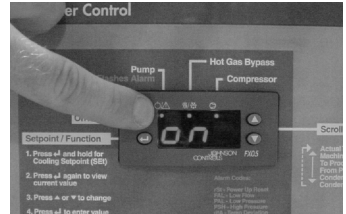

**NOTE:** When you press the Stop/Start Chiller button, the pump and compressor both stop. If you try to restart immediately by pressing the Stop/Start Chiller button, the pump will turn on but the compressor will not turn on for three minutes. The Process Pump light on the control panel will light immediately. After three minutes the compressor turns on and the Compressor light on the control panel lights.

## TIC Control Changing Adjustable Parameters

The control allows you to change 13 settings:

- Temperature Units-UN-F
- Lower Setpoint Limit-LtS-45
- Process Variable-PUS-A
- Tuning the Chiller-PiT-nor
- Low Pressure Alarm-LP1-5 sec.
- Deviation temperature ignore time-Dtt-300 sec.
- Flow Switch time-FS1-10
- Low Temperature Alarm Setpoint-SPL-39
- High temp alarm-HtA-85
- High temp safety-HtS-95
- Deviation temperature-Dt-10
- Alarm Bell Acknowledge time-AAT-0
- Software revision-CO1 (read only)

Settings are factory preset and will fit most applications. Once your system parameters are established these values are rarely accessed and changed. If you have any problems or questions, see the next few sections, or call your Conair Service representative.

# TIC Control Changing the Temperature Units (UN)

The Temperature units parameter allows selection of the displayed temperature units. The available selection is either degrees Celsius or Fahrenheit. °C or °F depicts this.

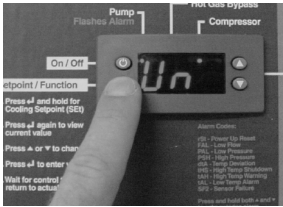

- 1 Press the Enter key unit the default configuration page UN is displayed.
- 2 Press Enter again to show °C or °F.
- 3 Toggle between the up/down to select your desired units.
- 4 Press Enter to accept the units.



# TIC Control Changing the Low Setpoint Limit (LtS)

The default low temperature limit for the to process fluid is factory set at 45 °F. This temperature limit is the lowest temperature you can operate the chiller at without adding Glycol. If you want to operate below this factory setting, you will need to adjust this setting accordingly. Additionally, you will need to add the correct percent of Glycol to the process water side of the system and adjust the (SPL). See Filling the Chiller, Section 3.

Once the chiller is filled with the correct percent of Glycol proceed to set the Low Setpoint Limit.

- 1 Press the Enter key unit the default configuration page UN is displayed.
- 2 Toggle up/down keys until LtS displays on the screen. LtS flashes, along with the current low limit temperature.
- 3 Press Enter and Press up/down until you get to the desired value.
- 4 Press Enter to accept the new value.



To return to the To Process Temperature screen from any other screen, press and hold the  button for at least 5 seconds until the temperature displays.

 **NOTE:** Setback will show down to 20°F but it is limited by the variable to 40°F unless changed.

# TIC Control Changing the Process Variable (PUS)

The Process variable selector allows the operator to select the controlled temperature from the following: To Process, From Process and Average. The default is the average temperature and the tuning parameters are set up for this. If the chiller is used in a no tank system then the From process temperature should be selected.

Depending on system size select the appropriate tuning parameter set, See Tuning the Chiller.

This features allows the operator to select the controlled temperature from the following: To process, From process and Average. The default is set at Average.

- 1 Press the Enter until the default configuration page UN.
- 2 Toggle up/down keys until until PUS flashes on the display
- 3 Press Enter and use the up/down keys to select “to” fro” or A”.
- 4 Press Enter to accept the units.



# TIC Tuning the Chiller (PiT)

The controller has three pre-configured tuning parameter sets, one of which should allow optimum temperature control. Following is a description of each of the choices available to an operator:

### Slow Responding system:

Select the slow setting “SLO” for large systems. More than 1,700 pounds (200 gallons) of water and more than 14,000 lbs of steel might be considered a large system. This setting has the smallest proportional band (1°F), which allows larger changes in the control output when the process temperature is far from setpoint. This should reduce cycling around the setpoint.

 **NOTE:** Normal parameter is the factory setting.

### Normal Responding System:

Normal “nOr” is the factory default tuning setting, as it will cover the majority of applications. This setting is appropriate for systems with 250 to 1,700 pounds {30-200 gallons} of water and 2,000 to 14,000 pounds of steel. The default value for the normal proportional band is 2°F.

Continued

# TIC Tuning the Chiller (PiT) Continued

## Fast Responding System:

Select the fast setting “FSt” for small systems. Less than 250 pounds of water { 30 gallons } and 2,000 pounds of steel might be considered a small system. This setting has the largest proportional band (4°F), which allows a fast response to small deviations between the process variable and setpoint. This system is typical for small chillers with small molds or other process machinery. If improperly set up, the configuration might cause oscillation around the setpoint temperature.

## Setup Menu

To access the Setup Menu,

**1 Press and hold the “enter” key for approximately five seconds, until the service menu is active.**

**2 Toggle the Up/Down keys until “PiT” is displayed. Press the “enter” key once to see the current tuning setting.**

**3 Toggle the Up/Down arrow keys to the desired SLO, nOr or FSt setting. Press “enter” again to save this value. If at any time not key is pressed for 10 seconds the control will return to “Home Page”, displaying the process variable. If the unit is in any alarm condition, you must clear it before you can adjust the tuning selector.**



# TIC Control Changing the Low Pressure Alarm Ignore Time (LP1)

This feature allows you to set the time from when a low refrigerant pressure alarm is sensed to when the alarm signals. The range for this alarm is 0-60 seconds; standard default value is 5 seconds. This default value should be adequate for all systems and should not need to be adjusted. This alarm can cycle up to three times per hour before a latching shutdown occurs. Once a latching shutdown occurs “PAL” will flash on screen and the unit will need reset.

**1 Press the Enter key until the default configuration page Un appears on the screen.**

**2 Toggle up/down keys until until LP1 flashes on the display**



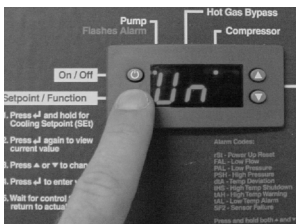

**3 Press Enter and use the up/down keys to select your desired amount of time.**

**4 Press Enter to accept the units**







## TIC Control Changing the Deviation Temperature Ignore Time (Dtt)

The deviation temperature ignore time is the time from when a deviation from setpoint is sensed until it is displayed. The deviation from setpoint occurs when the actual temperature of the fluid is some value away from the setpoint (value is set by dt). The deviation temperature ignore time range is 0-600 seconds, the default is 300 seconds and should be sufficient for most applications.

- 1 Press the Enter key until the default configuration page Un appears on the screen.** 
- 2 Toggle up/down keys until until Dtt flashes on the display**   

- 3 Press Enter and use the up/down keys to select your desired amount of time.** 
- 4 Press Enter to accept the units.**

## TIC Control Setting the Flow Switch Delay Time (FS1)

This flow switch feature ensures that there is adequate flow through the evaporator before allowing the compressor to start. The value set in this parameter is the time after start-up that the control will wait for the flow switch to be made before shutting down. If shut down occurs, FAL will flash on the control and request the unit to be reset. Proceed to troubleshooting section if this occurs. The range is 0-20 seconds, the default value is 10 seconds and should be adequate for most applications.

- 1 Press the Enter key until the default configuration page Un appears on the screen.** 
- 2 Toggle up/down keys until until FS1 flashes on the display**   

- 3 Press Enter and use the up/down keys to select your desired amount of time.** 
- 4 Press Enter to accept the units**

# TIC Control Changing the Low Temperature Alarm Setpoint (SPL)

The low limit temperature alarm setpoint is the setpoint that protects the chiller from undershooting the required process water temperature. The range for this setting is 19.4-79 and the default is 39. For most applications this value will need to be set about 3°F below the LTS value.

**1 Press Menu button until UN is displayed.**



**2 Press Enter again to display value of Low Limit Setpoint to raise and lower the low limit setpoint temperature.** Each time you press the arrow the temperature changes one unit. Stop when you reach the temperature you want.



**3 Press the Enter button, to accept the new setpoint temperature.** The display returns to the actual process temperature.

# TIC Control Setting the High Temperature Alarm (HtA)

This feature will indicate when the chilled water system temperature is above an acceptable level. This alarm will be indicated by a flashing HtA. This is not a shut-down alarm, only an indicator. The setpoint range is 50-95 and the default is 85°F, which should be adequate for most applications.

**1 Press Menu button until UN is displayed.**



**2 Toggle up/down key until HtA flashes on the display.**







**3 Press Enter and use the up/down keys to select your desired amount of time.**



**4 Press Enter to accept the units.**





# TIC Control Setting the High Temperature Safety (HtS)

The High temperature safety is the highest temperature the process water temperature can get before a shutdown. If shutdown occurs it will be indicated by a flashing (HtS). Range for this parameter is 75-95 and default value is 95°F.

- 1 Press Menu button until UN is displayed. 
- 2 Toggle up/down key until HtS flashes on the display.   

- 3 Press Enter and use the up/down keys to select your desired amount of time. 
- 4 Press Enter to accept the units.





# TIC Control Changing the Deviation from Setpoint Temperature (DT)

This is the temperature value that the actual temperature can be away from the setpoint. If the actual temperature is more than the deviation value above or below the setpoint the Dtt will initiate and a passive alarm dtA will occur 300 seconds later.

- 1 Press the Enter key until the default configuration page Un appears on the screen. 
- 2 Toggle up/down buttons until display flashes dt, press “Enter”. Use the up/down buttons to set your desired deviations setpoint temperature.   

- 3 Press the Mode/Enter button, to accept the new setpoint temperature. 

# TIC Control Changing the Alarm Acknowledge Timer (AAT)

The Alarm Acknowledge timer (AAT) sets the time that an alarm can be acknowledged and silenced without being satisfied. The default value of this parameter is 0 minutes. In this case the alarm silence does nothing and alarms can only be cleared after the alarm condition is nullified. The range of times that can be programmed is 0-60 minutes.

- 1 Press the Enter key for 5 seconds to show the default configuration page UN. 
- 2 Toggle up/down keys until until AAT flashes on the display   

- 3 Press Enter and use the up/down keys to select your desired amount of time. 

 **NOTE:** In the very rare case that none of these settings provide adequate control, please consult the Conair service to further adapt these variables.

# TIC Control Reading the Software Version (co1)

The Version of the software is depicted by the c “xx” parameter. This “read only” parameter and depicts the version of the software that has been downloaded into the controller. This number will be a paramount importance in obtaining service support. EX CØ1 is version 01 of the chiller program.

## TIC Alarms

### Alarm Stage

When the controller senses an alarm, the specific alarm flashes, alternating with the actual process variable on the display. These alarms must be cleared when a safe condition exists. In addition when a power up condition exists the display will flash RST to alert the operation that the controller must be reset before operation can continue/begin.

The final area that informs the user is the alarm stage. All alarms are indicated by flashing Pump LED.

There are three types of alarms that are resident in the controller.

### First type of Alarm

The first type of alarm is the annunciating, cycling type. This alarm will flash its code opposite the process variable, but does not shut the compressor down. These alarms are:

**DtA:** The deviation from setpoint alarm energizes when the displayed temperature is above or below the setpoint by more than the deviation temperature setting (dT) and for longer than the deviation temperature ignore time(dtt).

**TAH:** This is a warning alarm only and will flash when the process temperature gets above this alarm setting (htA).

### Second type of Alarm

The second type of annunciating alarm will cycle three times in one hour before latching and requiring reset. The low refrigerant pressure alarm PAL is this type of alarm. The optional bell and strobe will energize while the system is in low pressure but turn off when the pressure switch is satisfied.

## TIC Alarms Continued

**PAL:** (Pressure alarm low) flashes when the low refrigerant pressure switch has sensed low pressure for more than the low pressure ignore time (LP1). This is a cycling alarm up to three times per hour.

### Third type of Alarm

Third type of alarm is a latching type. This alarm shuts down the compressor on the first trip and must be manually reset upon correction of the fault condition.

The indicators that flash when the unit is in alarm are:

**RSt:** Flashes on restoration of power after a power loss.

**PSH:** Flashes on the Refrigerant high-pressure switch. This is a latching alarm and the high-pressure switch might require to be manually reset before this alarm can be acknowledged.

**SF2:** Indicates that the To process temperature sensor is indicating out of range.

**THS:** Indicates that the compressor has shut down due to high temperatures to the process that could damage the compressor (Hts)

**FAL:** (Flow alarm low) flashes when the process water flow switch has detected a low flow condition for longer than the low flow ignore timer (fsl).

**TAL:** The low temperature alarm shuts down the compressor when the leaving water temperature sensor detects a temperature below the low temperature alarm setpoint(spl).

The final alarm is the compressor maintenance alarm. The alarm flashes the run light but does not indicate on the display.

# PLC Control Powering Up

Plug in the power cord to restore power after any required maintenance.

## 1 Turn on the main power.

The chiller control automatically performs its bootup routine. The screen displays Press Enter to continue.

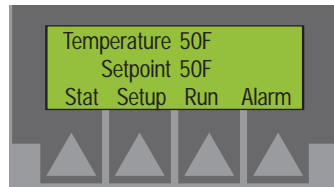

The main screen lets you:

- **view the status** of the To and From process temperature, process setpoint, suction pressure, percent glycol, low temperature cutout and discharge pressure.
- **view and change the setups** for temperature setpoint, Autotune mode, high temperature deviation, and percent glycol solution
- **run or stop the chiller**
- **view alarm information**
- **perform maintenance with password clearance**

## 2 Press the arrow pointing to the selection you want displayed on the screen.

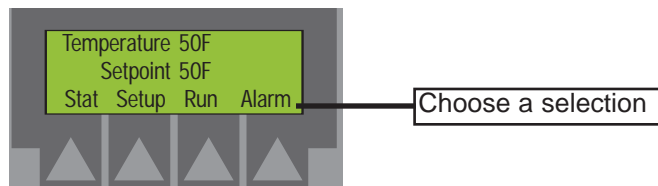

# PLC Control Setup Menu

The PLC control allows you to program various parameters for the Chiller:

- **Temperature Setpoint**  
The temperature you want the To Process liquid.
- **High Temperature Deviation**  
Set the number of degrees the temperature can rise above the setpoint temperature without an alarm.
- **Percent Glycol by Volume**  
Use when you use an ethylene glycol or propylene glycol and water solution to lower the To Process temperature. Changing the percent glycol automatically changes and display the low temperature cutout, in °F.
- **Fans** (Air-cooled only)  
Set the upper and lower temperatures for the fans to cycle. This screen is password protected.

 **NOTE:** If you do not need to change any settings on the control, go to Running the Chiller.

To program settings from the Main screen:

## 1 Press the Setup arrow.

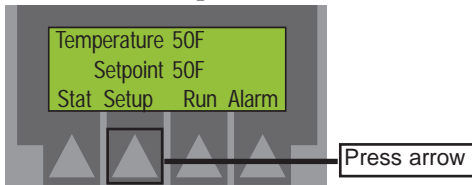

The first Setup screen displays:

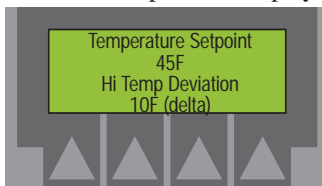

## 2 Press the Up and Down Scroll arrows to scroll through the Setup screens. Stop at the one you want to change.

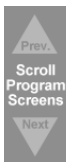

# PLC Control Viewing Run Menu

After you have viewed all the Status screens and made any necessary changes to the Setup screens, you are ready to run the Chiller. To run the chiller from the main screen:

## 1 Press the Run arrow on the Main screen.

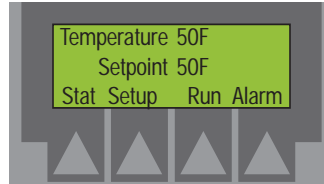

## 2 Press the RUN arrow.

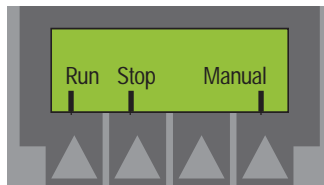

In Run mode the compressor cycles off at 4° below the setpoint if the load is too low for the hot gas to keep the compressor from shutting down. If the compressor shuts down it will not restart until after 3 minutes and only if temperature is at least 1°F above setpoint.

If you want to stop the compressor and continue to run the pump, choose following.

## 3 Pumpdown sequence

From Run Menu, choose Manual then press Next and select Pumpdown. The liquid line solenoid valve will close while compressor remains on until refrigerant is pumped down to 28 psig, then the compressor will cycle off.



To stop the chiller at any time, press the Function Key Stop button on the control.



The chiller control and display screen remain on, but the pump and compressor stop.

To disable pumpdown, press previous twice, then press Run.

If you try to restart immediately, the pump will turn on but the compressor will not turn on for three minutes. The Process Pump light on the control panel will light immediately and the compressor light will flash. After three minutes the compressor turns on and the Compressor light on the control panel lights.

# PLC Control Viewing Run Menu

The Status screens are read-only screens. You cannot make changes to these screens. To view the status screens:

## 1 Press the Status arrow on the Main screen.

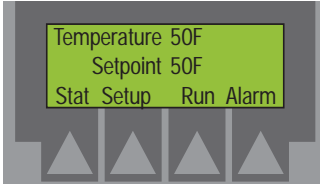

The Status button does not let you change the status, only view it.

## 2 Use the scroll arrows to scroll through the status screens.

Verify that the readings each screen displays are the ones you want. You cannot change the readings of the screens from the Status screens. You can change the status of:

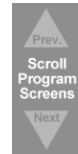

- **Setpoint temperature**
- **Percent Ethylene Glycol by volume**

by going to the Setup screens. You can not change the other readings; they are read-only screens, reporting environmental conditions.

## 3 Press the Escape/Previous button at any time to return to the main screen.

 **NOTE:** Normal setpoint operating range is 40-65°F {4.4-18.3°C}. If glycol is added to the chiller and the percent glycol is entered into the control, the PLC automatically adjusts the setpoint operating range.

# PLC Control Viewing Run Menu

## Continued

Status screens include:

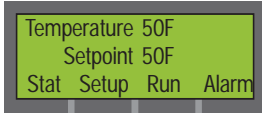

### Temperature

Displays the To Process temperature and the Setpoint temperature. To change the Setpoint temperature, go to Changing Setpoint Temperature, in the Operation section.

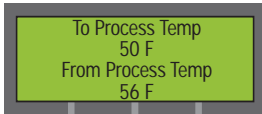

### From Process Temp

Shows the temperature of the fluid entering the chiller. Can display in degrees Fahrenheit or Celsius.

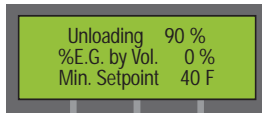

### Percent chiller load

Shows the current percent of chiller capacity being used. This percentage is a read-only value and changes as the chiller cycles.

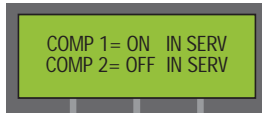

### Compressors (for units with dual compressors, 20 ton+)

Displays the activation status of the two refrigeration circuits, compressor 1 and compressor 2. ON is activated; OFF is disabled. Lists In/Out of Service for each.

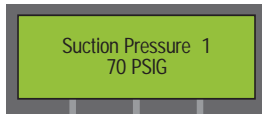

### Refrigerant suction pressure

Shows the status of the refrigerant suction pressure in PSIG for compressor(s) 1 and 2, if chiller has dual compressors. NOTE: Typical refrigerant suction pressure is between 55 PSIG and 95 PSIG.



### Refrigerant Discharge pressure

View the status of the refrigerant discharge pressure in PSIG for compressor(s) 1 and 2, if chiller has dual compressors. Typical discharge pressure is between 190 PSIG and 325 PSIG.

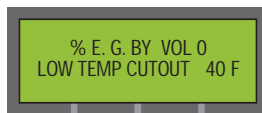

### Percent Ethylene Glycol by Volume and Low Temperature Cutout

Displays the percentage of ethylene glycol or propylene glycol solution (by volume) in the chiller in degrees Fahrenheit. Changing the percent glycol automatically changes the low temperature cutout.

# PLC Control Changing Setpoint Temperature

Use the Temperature Setpoint to set the temperature you want to the water to be exiting the chiller at the To Process connection.

To display the Setpoint temperature from the Main screen, press the Setup arrow. The Setpoint screen displays:

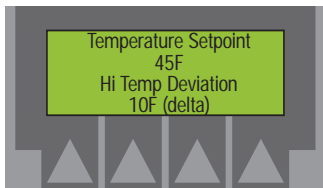

The current setpoint temperature displays in both Fahrenheit (F) and Celsius (C). The temperature in °F flashes.

## 1 Press the Shift Key to change the setpoint then select value and press enter.

Use the numeric keypad to set the temperature setpoint. Press the numbers for the temperature you want, then press the Enter button to save.

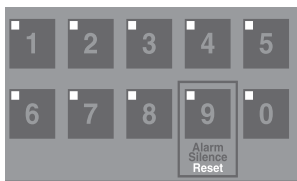

## 2 Press the Scroll arrows to scroll to the next Setup screen, or press the Escape/Previous Screen button to return to the main screen.

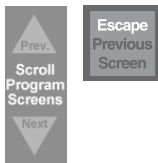

# PLC Control Changing High Temperature Deviation

Decide how many degrees above the setpoint you will allow the chiller to deviate before an alarm occurs.

To set the high temperature deviation:

## 1 Press the Setup arrow.

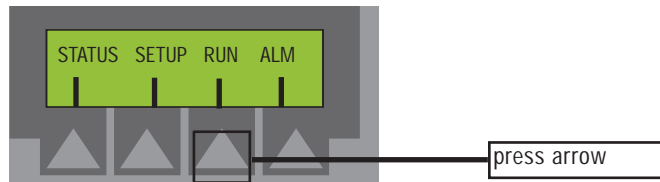

Continue to press the arrow to scroll through the Setup screens. Stop when you get to the High Temp Dev screen. The current high temperature deviation number displays along with the - and +. The number flashes on the screen.



## 2 Press the - or + arrows to set the high deviation to the appropriate number.

Each press of the (-) arrow decreases the high deviation by one unit; each press of the (+) arrow increases the high deviation by one unit. Stop when you reach the number you want. The allowable range is 3 - 20°F.

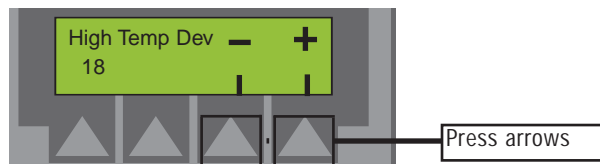

OR

Use the numeric keypad to enter the number for the high deviation. After using the keypad press the Enter button to save.

## 3 Press the Scroll arrows to scroll to the next Setup screen, or press the Escape/Previous Screen button to return to the main screen.



# PLC Control Setting Percent Glycol

To set the percent ethylene glycol or propylene glycol solution, determine the temperature of the process fluid you want.

Use water as the coolant for chilling the process fluid down to 45°F {7°C}. Below 45°F {7°C} and down to 20°F {-7°C}, use a glycol and water solution 0-33% range.

Use the table to choose the proper percentage of glycol solution for the required temperature.

Recommended Percentages of Glycol for Chilled Water Freeze Protection		
Discharge water Temperature	% Propylene Glycol	% Ethylene Glycol
Above 45°F	0	0
40°F	20	15
35°F	25	20
30°F	35	30
25°F	40	35
Below 25°F	Consult Factory	

**NOTE:** If you are using water as the coolant, set the Percent Glycol to zero on the control.

**CAUTION:** Improper setting could result in the evaporator freezing. Damage from the evaporator freezing is not covered by the warranty.

After choosing the temperature you want, mix the glycol solution to the proper percentage and fill the chiller according to the directions in Filling with Glycol Coolant, in the Installation section.

Program the percentage glycol solution into the control. From the main screen:

- 1 Press the Setup arrow.** Use shift key to change value. The Minimum setpoint and low temp cutout, they will automatically change after entering value.

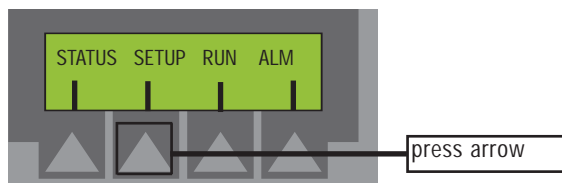

# PLC Control Setting Percent Glycol Continued

 **NOTE:** If you are using water as the coolant, set the Percent Glycol to zero on the control.

**2 Press the UP/Down Scroll arrows to scroll through the setup screens.**

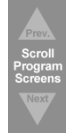

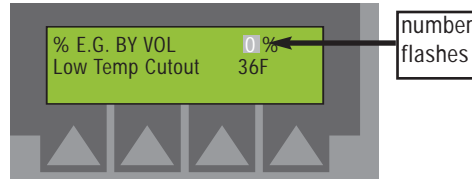

Stop when you get to the Percent Glycol screen:

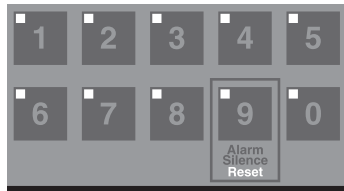

The screen displays the percent of glycol by volume currently used. This number is flashing. The screen also displays the low temperature cutout (If the To Process fluid drops below this temperature, an alarm condition occurs and the compressor shuts off.)

**3 Use the numeric keypad to set the percent glycol.** Make sure the percent you enter is the same as the percent mixture you added to the chiller. See Filling the Chiller, in the Installation section.



 **NOTE:** This screen has password protection. You can change the percent glycol only if you have clearance. A screen displays: **\$316 Password level invalid...** The password screen then asks for the password. Enter the password (999). You now have password access for five minutes. Otherwise, press the Escape button to return to the Main screen.

**4 Press the Scroll arrows to scroll to the next Setup screen, or press the Escape/Previous Screen button to return to the main screen.**

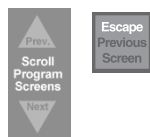

# Selecting the Temperature Scale

You can choose to display the temperature in either Fahrenheit or Celsius. To select the temperature scale:

## 1 Press the Setup arrow.

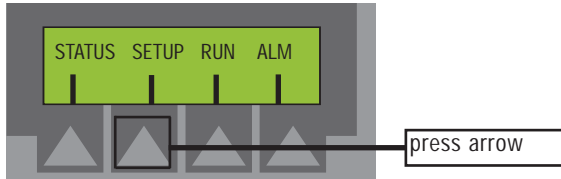

## 2 Press the Scroll arrows to scroll through the Setup screens.

Stop when you get to the Select Scale screen. The current choice is listed.

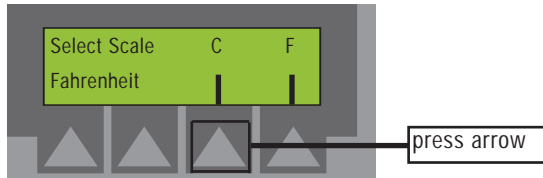

## 3 Press the arrow for the scale you want, F or C.

Note that the High Temperature Deviation value and the Alarm History Temperatures are displayed in Fahrenheit scale regardless of which scale is selected on this screen.

# PLC Control Resetting PID Settings

Use the PID reset to return the control to the factory settings. Use this if the autotune does not give good values or good values are lost.

To reset PID from the main screen:

- 1 Press the setup arrow. Press Next.**

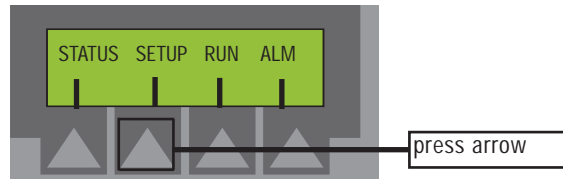

- 2 Press the Scroll arrows to scroll through the Setup screens. Stop when you get to the PID Reset screen. Use this screen to reset the PID controls, set the discharge pressure setpoint (DPS) for water-cooled chillers, and to set the on/off discharge pressure setpoint for the air-cooled chillers with the VFD option.**

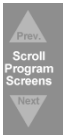

- 3 Press the PID Reset arrow.**



- 4 Press the scroll arrows to move to the next setup screen, or press Escape/Previous Screen button to return to the main screen.**

Setup Menu also has Maintenance values. *SEE Maintenance section.*

# PLC Control Setting Fan Setpoints

For the Air-cooled Portable Chillers you can choose the condenser pressures in PSIG at which the fan cycles on and off. To set the Fan Setpoints from the main screen:

## 1 Press the Setup arrow.

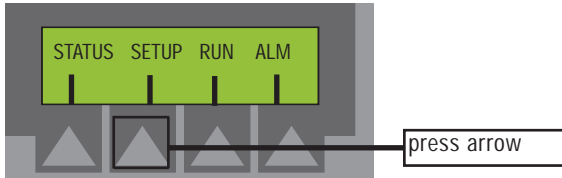

## 2 Press the Scroll arrows to scroll through the Setup screens.

Stop when you get to the PID Reset screen.

## 3 Press the Fans arrow.

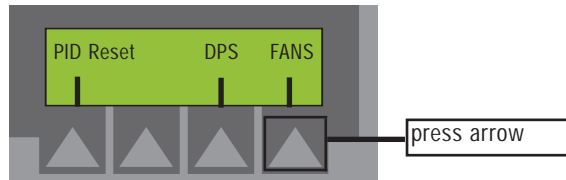

A screen displays asking for the password. Use the Keypad to enter the password (999) and then press the Enter button. The Fan Setpoint screen displays:

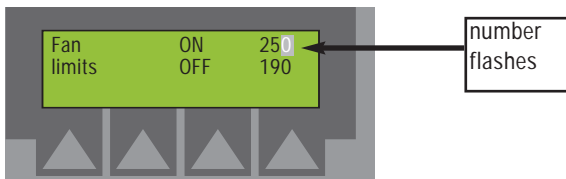

The screen shows the upper and lower condenser pressure limits for the fan. The ON pressure flashes. Use the keypad to change this number. Then press Enter button to save the new number.

## 4 Press the Scroll arrow to move to the OFF setting. The OFF number flashes:

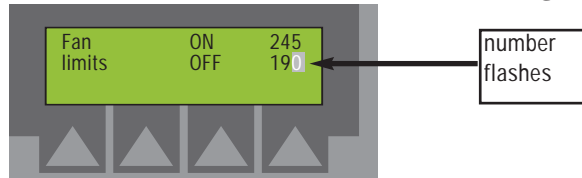

Use the keypad to change the OFF number.

**NOTE:** This screen is password protected. You must have clearance to enter and change this setting

# PLC Control Setting Fan Setpoints

**5** Press **Enter** to save the change.



**6** Press the **Escape/Previous Screen** button to return to the main screen.



Fan setpoints are not saved in retentive memory and are lost when power is disconnected. Factory default values are reloaded on power up.

# PLC Control Setting Discharge Pressure Setpoint

You can select the refrigerant discharge pressure setpoints in PSIG. To set the discharge pressure setpoints from the main screen:

- 1 Press the Setup arrow.

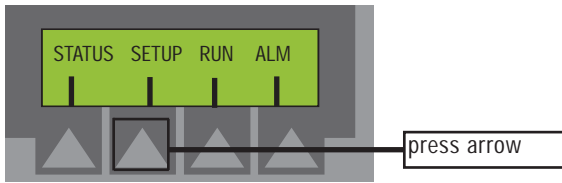

- 2 Press the Scroll arrows to scroll through the Setup screens. Stop when you get to the PID Reset screen.

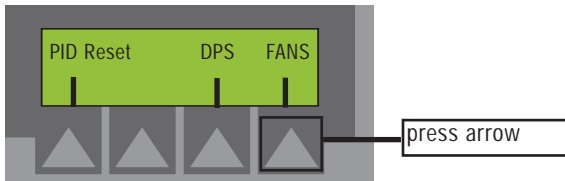

- 3 Press the DPS arrow. The Discharge Pressure Setpoint screen displays.

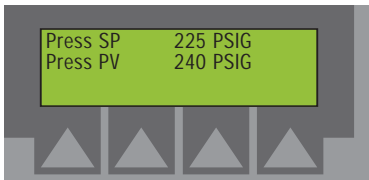

The pressure setpoint (SP) and the pressure process variable (PV), both in PSIG are listed. Change the value of the pressure setpoint by entering the new number with the Select Value buttons.

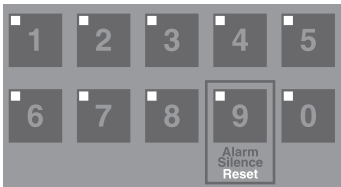

The discharge pressure can be set between 100 and 350 PSIG.

- 3 Press the Enter button to accept the new value.



# PLC Control Selecting PID Values

The PID values are set at the factory to default settings. The values should be changed only if the water regulator valve or the VFD are unable to maintain discharge pressure. To set the discharge pressure setpoints from the main screen:

## 1 Press the Setup arrow.

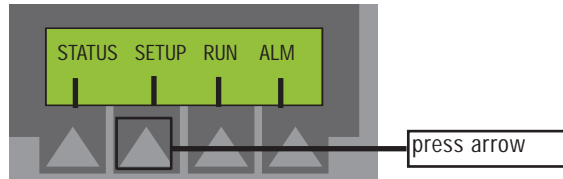

## 2 Press the Scroll arrows to scroll through the Setup screens. Stop when you get to the PID Reset screen.

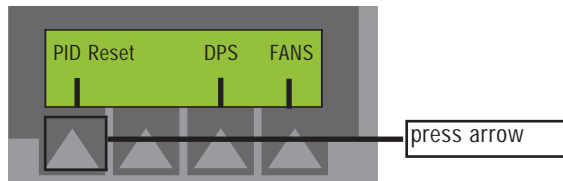

## 3 Press the PID Reset arrow. The PID values for Gain and Reset time display. The gain is dimensionless (i.e. has no units) and the integral value, or Reset time, is measured in seconds. There are no upper or lower limits for these settings.

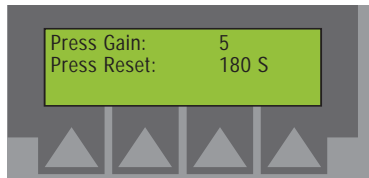

Use the Select Values buttons to change the gain and reset.



## 4 Press the Enter button to accept the new value. If the PID values need to be restored to the factory default settings scroll to the Reset Factory PID screen from the Setup screen.



Press the Reset arrow. Gain restores to 2 and Reset restores to 180 seconds.

# PLC Control Manually Starting/ Stopping the Pump

To run or stop the pump from the main screen:

- 1 Press the arrow pointing to Run on the screen.

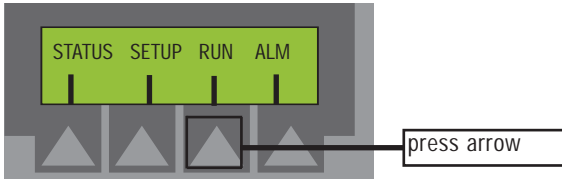

The first Run screen displays.

- 2 Use the Scroll arrows to scroll through Run screens to the Manual Pump screen.

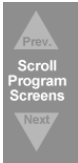

- 3 Press the arrow pointing to your choice.

If the pump is running and you want to stop it, press the arrow pointing to Off. Alternate: pressing red extended head button stops the pump if that is all that is running. If the pump is stopped and you want to run it, press the arrow pointing to On.

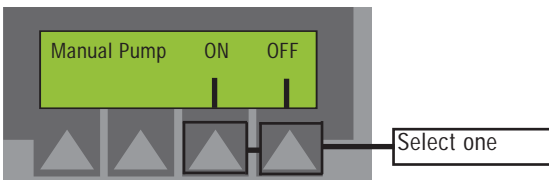

- 4 Press the Escape/Previous Screen button.
- The control returns to the main screen.





# Maintenance

---

Maintenance features . . . . .	5-2
Warnings and cautions . . . . .	5-3
Preventative maintenance schedule . . . . .	5-4
PLC control entering maintenance screens . . . . .	5-6
Checking electrical connections . . . . .	5-7
Cleaning the brazed plate evaporator or water-cooled condenser . . . . .	5-8
Cleaning the air-cooled condenser . . . . .	5-9
Checking the refrigerant charge . . . . .	5-10
Checking reservoir level . . . . .	5-11
PLC control setting auto tune mode . . . . .	5-12

# Maintenance Features

Conair Series PCA/PCW chillers need regular, scheduled maintenance for peak performance.

To maintain the best performance of the chiller, it must be cleaned and inspected regularly. Maintenance includes a daily, monthly, and semi-annual schedule.

Use this maintenance schedule as a guide. You may need to shorten the time of the maintenance schedule, depending on how often you use the chiller. Among the features that require preventative maintenance are:

- the refrigerant system
- electrical cables, terminals, and control lights
- the condenser, condenser filter strainer at inlet
- caster locks
- temperature and pressure readings
- process fluid level
- efficiency
- evaporator, filter strainer at evaporator inlet
- cooling water treatment system (if used)

# Warnings and Cautions



**WARNING: Improper installation, operation, or servicing may result in equipment damage or personal injury.**

This equipment should only be installed, adjusted, and serviced by qualified technical personnel who are familiar with the construction, operation, and potential hazards of this type of machine.

All wiring, disconnects and fuses should be installed by qualified electrical technicians in accordance with electrical codes in your region.



**WARNING: Electrical Hazard**

Before performing any work on this item, disconnect and lock out electrical power sources to prevent injury from unexpected energization or startup. Be sure that power to the chiller is OFF when doing any maintenance on the chiller. Follow all safety rules when performing any maintenance on this equipment.



**CAUTION: Hot Surfaces**

Always protect yourself from hot surfaces when working on the Portable chiller, especially when working on or around the compressor and condenser. These devices can reach up to 160°F {71°C}. Allow these devices to cool before performing any maintenance or troubleshooting.



**WARNING: Refrigerant hazard**

Only certified refrigerant technicians should examine and correct problems involving the refrigerant circuit.



**WARNING: Hazardous substance**

When burned, Freon R22 refrigerant forms Phosgene gas. If the chiller is placed in the vicinity of equipment with combustible systems, the combustion air intake must be ducted in from the outside and sealed in such a manner as to prevent any refrigerant from entering the combustion chamber. Refer to the Material Data Sheet for Freon R22. This sheet explains the potential hazards and how to avoid them.

# Preventative Maintenance Schedule

To maintain the best performance, follow the maintenance schedule and record information in the Maintenance Log in the Appendix.

## Daily, or as often as needed

- Checking process fluid level in the pump tank**  
Check the process fluid level in the water level gauge on the back of the chiller. If low, see Filling the Chiller, in the Installation section.
- Verifying pump discharge pressure**  
While the pump is running, check that the pump pressure gauges are within range. To change the pressure open or close the To Process valve.
- Inspecting piping for leaks**  
Check to see that pipes are not leaking. Look for standing water on the floor or inside the chiller cabinet.
- Inspecting the condenser coil for debris**  
(air-cooled models only). Remove the wire mesh side panel and filter in front of the condenser coil. Remove any debris from the coils.

**IMPORTANT:** We recommend wire terminations being tightened during any servicing of the chiller.

## Weekly, or as often as needed

- Checking temperature and pressure readings**  
Check that the temperature displays on the control screen, and that the pressure gauge indicates normal operation.
- Checking efficiency**  
Review the performance data on the Maintenance Log found in the Appendix. If you notice a decrease in efficiency over time, check all heat transfer surfaces of the evaporator and condenser for fouling. Clean as needed.
- Checking refrigerant site glass**  
There should not be any bubbles. See Checking Refrigerant Charge, in the Maintenance section.
- Checking reservoir level**  
Check the water level gauge on the back of the chiller. If fluid level is low, fill. See Checking Reservoir Level, in the Maintenance section.

# Preventative Maintenance Schedule

## Monthly

- Inspecting cooling water treatment system**  
If your chiller uses a cooling water treatment system, maintain proper chemical levels and follow the recommendations of your water treatment specialist. Change water in the reservoir tank monthly.
- Checking electrical connections, amps, volts**  
Make sure electrical connections are properly seated. See Checking Electrical Connections, in the Maintenance section. Check fan, compressor, and pump amps and volts.
- Cleaning**  
Wipe all external surfaces to maintain performance.
- Inspecting condenser**  
Check the condenser for adequate air flow or water flow. Check the condenser face for dirt and clogging. If dirt or clogs are present, clean the condenser. See Cleaning the Evaporator or Water-cooled Condenser, and Cleaning the Air-cooled Condenser, in the Maintenance section. Check, clean, and replace the filter at the air inlet of the Air-cooled condenser coil, as needed.
- Inspecting the control panel**  
Check for loose wires, burned contacts, and signs of overheated wires. Check that all panel lights illuminate. See Checking Electrical Connections section.
- Checking refrigerant charge**  
With the compressor running, check the sight glass between the receiver and evaporator for proper refrigerant condition. See Checking Refrigerant Charge, in the Maintenance section.
- Cleaning process fluid evaporator strainer**  
Remove cap and clean any debris out of strainer. Replace cap.

## Annually

- Cleaning the evaporator or water-cooled condenser**  
See Cleaning the Evaporator or Water-cooled Condenser, in the Maintenance section.
- Check refrigerant piping**  
Verify that no oil is present on fittings or cabinet. Wipe clean and check charge/operation of circuit.

To maintain the best performance, follow the maintenance schedule and record information in the Maintenance Log in the Appendix.

# PLC Control Entering Maintenance Screens

The Maintenance screens are password protected. You must have clearance to enter and change settings on these screens.

If the control buttons are not used for 5 minutes, the PLC defaults to the Temperature/ Setpoint screen. You must then re-enter the password to use the Maintenance screens.

Use the Maintenance screens to view cycling information. The cycle screens display the total cycles or hours since the initial assembly of the chiller. These numbers are only reset by Conair Service personnel. To view the cycle information:

## 1 Press the Setup arrow.

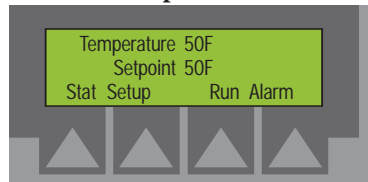

## 2 Press the Scroll arrows to scroll through the setup screens. Stop when you get to the Maintenance screen:



## 3 Press the Maintenance arrow. The password screen displays. Use the keypad to enter the maintenance password,999, then press the Enter button.

## 4 Scroll through the Maintenance screens.

They include:

- **Cycle screens** - view the cycle times for chiller components
- **Tuning screens** - initiate PID auto tune sequences for the hot gas bypass control for the compressor
- **Compressor service screen** - (dual compressor models only) choose the lead compressor (1 by default), and take a compressor in or out of service (IN by default)
- **Conair factory screen** - (unavailable to user)
- **DI & DO**
- **Screen contrast adjustment**



## 5 Press the Escape/Previous Screen button to exit the Maintenance screens and return to the main screen. The password stays in effect for 5 minutes after using it; after 5 minutes the screens return to the User Level.



# Checking Electrical Connections



## **WARNING: Electrical Hazard**

Before performing any work on this item, disconnect and lock out electrical power sources to prevent injury from unexpected energization or startup. Be sure that power to the chiller is OFF when doing any maintenance on the chiller. Follow all safety rules when performing any maintenance on this equipment.



**NOTE:** Always refer to the wiring diagrams you received with your chiller to locate specific electrical components.



## **WARNING: Improper installation, operation, or servicing may result in equipment damage or personal injury.**

This equipment should only be installed, adjusted, and serviced by qualified technical personnel who are familiar with the construction, operation, and potential hazards of this type of machine.

All wiring, disconnects and fuses should be installed by qualified electrical technicians in accordance with electrical codes in your region.

### **1 Be sure the main power is disconnected**

and the chiller is locked out. Always disconnect and lockout the main power source before opening the unit for servicing.

### **2 Open the electrical enclosure.**

### **3 Inspect all wires and connections.**

Look for loose wires, burned contacts, and signs of over-heated wires. Compare the PLC wiring to the wiring diagrams you received with your chiller. Have a qualified electrician make any necessary repairs or replacements.

### **4 Close the electrical enclosure door.**

### **5 Inspect the exterior power cords.**

Cords should not be crimped, exposed, or rubbing against the frame. If the main power cord runs along the floor, make sure it is positioned where it could not rest in pooling water or could not be run over and cut by wheels or casters.

# Cleaning the Brazen Plate Evaporator or Water-Cooled Condenser

Minerals and other contaminant's produce deposits, scales, slime, or algae on the heat transfer surfaces exposed to water. Fouled surfaces result in decreased cooling capacity. Implement a water treatment program to slow the fouling.



## CAUTION: Hot Surfaces

Always protect yourself from hot surfaces when working on the Portable chiller, especially when working on or around the compressor and condenser. These devices can reach up to 160°F {71°C}. Allow these devices to cool before performing any maintenance or troubleshooting.

Water quality should be maintained at a pH of 7.4, but not less than 6.0 for proper heat exchanger life.

To clean:

- 1 Prepare a 5% solution of Phosphoric acid or Oxalic acid and water. Do not heat the acid solution.**
- 2 Shut the optional To and From Process valve and Drain Reservoir.**
- 3 Disconnect the pump from the heat exchanger. Install a cap in the opening of the heat exchanger where the pump was connected.**
- 4 Remove RTD from bottom of evaporator.**
- 5 Connect 1/2-inch tubing to the 1/2-inch connections of the heat exchanger. SEE below to install customer supplied chemical pump and solution fitted to HTX.**
- 5b Close OFF condenser in and out and remove 1/2 inch HTX Plug to drain. Connect as shown below and Back Flush.**
- 6 Back-flush the solution through the heat exchanger and the chiller.**
- 7 Flush the heat exchanger and the chiller piping with fresh water after cleaning.**
- 8 Reconnect the chiller pump to the heat exchanger. Remove the cap in the heat exchanger and reconnect the hose from the pump.**

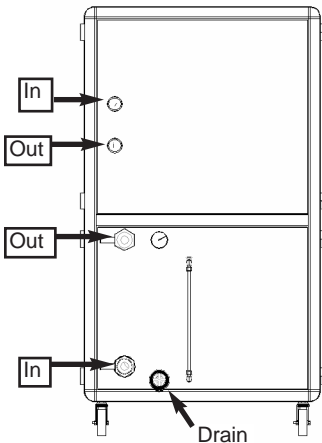

 **NOTE:** These connections may vary depending on the model you have purchased. Be sure to see the labeling on your particular unit.

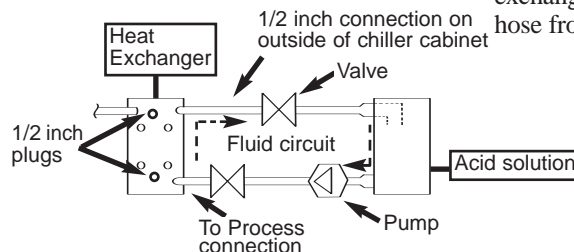

# Cleaning the Air-Cooled Condenser



## **WARNING: Electrical Hazard**

Before performing any work on this item, disconnect and lock out electrical power sources to prevent injury from unexpected energization or startup. Be sure that power to the chiller is OFF when doing any maintenance on the chiller. Follow all safety rules when performing any maintenance on this equipment.



## **CAUTION: Hot Surfaces**

Always protect yourself from hot surfaces when working on the Portable chiller, especially when working on or around the compressor and condenser. These devices can reach up to 160°F {71°C}. Allow these devices to cool before performing any maintenance or troubleshooting.

The air-cooled condenser can accumulate dirt and clog quickly if it is run in a dusty or dirty environment. A clogged condenser increases refrigerant discharge pressure, lowers performance, and may cause the fan motors and compressor to overheat.

- 1 Inspect the coils.** Use a flashlight to check between coil surfaces.
- 2 Clean the dirty coils with a soft brush.**
- 3 Flush with cool water or a commercial coil cleaner that is compatible with aluminum alloys.** It is recommended that the coil cleaner is sprayed from inside the cabinet.
- 4 Inspect and clean the air filter using water or air.** Replace as needed.



## **CAUTION: Wear eye protection.**

If you use compressed air to clean the equipment, you must wear eye protection and observe all OSHA and other safety regulations pertaining to the use of compressed air.

# Checking the Refrigerant Charge

All chillers are fully charged with refrigerant at the factory. Your chiller's model nameplate identifies the type and amount of total refrigerant charge required.



## **WARNING: Refrigerant hazard**

Only certified refrigerant technicians should examine and correct problems involving the refrigerant circuit.



## **WARNING: Hazardous substance**

When burned, Freon R22 refrigerant forms Phosgene gas. If the chiller is placed in the vicinity of equipment with combustible systems, the combustion air intake must be ducted in from the outside and sealed in such a manner as to prevent any refrigerant from entering the combustion chamber. Refer to the Material Data Sheet for Freon R22. This sheet explains the potential hazards and how to avoid them.

Check refrigerant charge while the chiller is running under load. Check the refrigerant charge through the sight glass. Use a flashlight, if necessary, and check the liquid-line sight glass:

- **Under full load conditions**, the refrigerant should be clear (no bubbles).
- **Under low load conditions**, when the hot-gas bypass valves are operating, bubbles may be visible in the sight glass. This is normal.

If the charge is low and the Chiller is under warranty, contact Conair service; or have a local, certified refrigeration technician add refrigerant to the system.

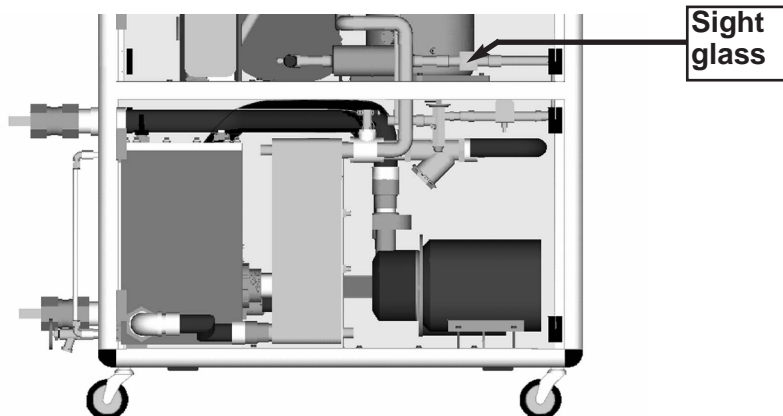

# Checking Reservoir Level



## **WARNING: Electrical Hazard**

Before performing any work on this item, disconnect and lock out electrical power sources to prevent injury from unexpected energization or startup. Be sure that power to the chiller is OFF when doing any maintenance on the chiller. Follow all safety rules when performing any maintenance on this equipment.

Check the fluid level in the reservoir. The meniscus in the sight glass on the back of the chiller should be 3/4 full.

To manually fill the reservoir:

- 1 Disconnect and lockout power to the chiller.**
- 2 Locate the fill/drain valve on the back of the chiller.**
- 3 Refill the reservoir.** Monitor the level using the water level indicator on the back of the chiller. Because the Portable Chiller can use either pure water or a glycol solution, make sure you are adding the correct fluid for your application.

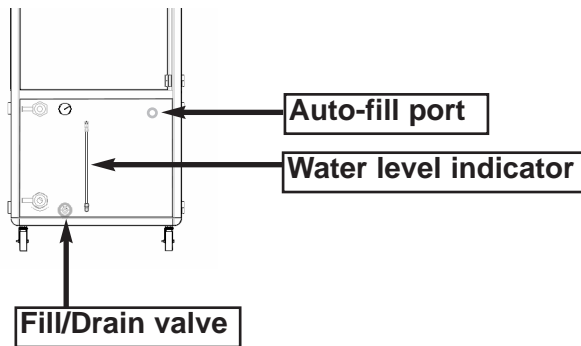

If you have the optional make-up water level float switch, it will automatically control the fluid level.

# PLC Control Setting Auto Tune Mode

 **NOTE:** This screen is password protected. You must have clearance to enter and change settings on this screen.

Use the Auto Tune Mode to maintain the temperature setpoint and minimize overshooting it. To set Auto Tune the chiller must be in Run mode. To run the Chiller from the main screen:

**1 Press the Run arrow on the Main screen.**

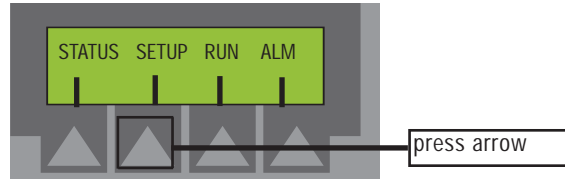

**2 Press the RUN arrow.**

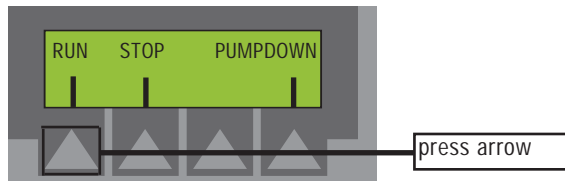

**3 Press the Escape/Previous Screen button.** The control returns to the main screen.

To display the Auto Tune Mode from the main screen:

**1 Press the Setup arrow.**

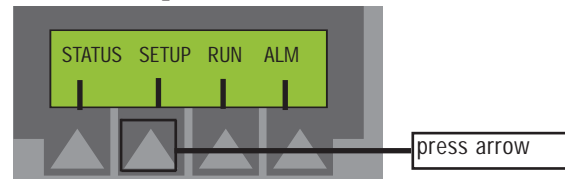

**2 Press the scroll arrows to scroll to the Maintenance screen.**



**3 Press the Maintenance arrow.**



# PLC Control Setting Auto Tune Mode Continued

The password screen displays.

- 4 Use the keypad to enter the password. The factory set password is 999.

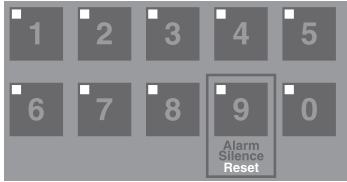

- 5 Press the Enter button to enter the password.



- 6 Press the Scroll arrows to scroll to the Tune screen.

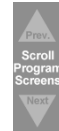

- 7 Press the Tune arrow.

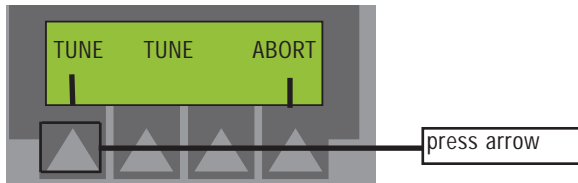

When the control begins tuning the screen displays TUNING message. The auto-tuning sequence takes about 15 seconds. The screen displays the 'TUNE Tuning' message. When tuning is complete, the screen displays the TUNE message. Press the Abort arrow to stop the auto-tuning sequence and return to the last good PID values.

- 8 Press the Escape/Previous Screen button to exit the Maintenance screens and return to the main screen.





# Troubleshooting

---

Before beginning . . . . .	6-2
A few words of caution . . . . .	6-3
Identifying the cause of a problem . . . . .	6-3
TIC control answering an alarm . . . . .	6-4
TIC control problems . . . . .	6-5
TIC control mechanical conditions . . . . .	6-7
PLC control answering alarms . . . . .	6-16
PLC control alarm conditions . . . . .	6-17
PLC control alarm errors . . . . .	6-20
PLC alarm history screens . . . . .	6-21
PLC control alarm screen legend . . . . .	6-22
PLC control control problems . . . . .	6-23
PLC control alarm problems . . . . .	6-25
Checking and replacing switches . . . . .	6-37
Replacing the RTD . . . . .	6-38
Removing pump components . . . . .	6-39
Replacing fuses . . . . .	6-40
Replacing the contractor . . . . .	6-41

# Before Beginning

You can avoid most problems by following the recommended installation, operation and maintenance procedures outlined in this User Guide. If you have a problem, this section will help you determine the cause and tell you how to fix it.

Before you begin troubleshooting:

- Find any wiring, piping, and assembly diagrams that were shipped with your equipment. These are the best reference for correcting a problem. The diagrams will note any custom features or options not covered in this User Guide.
- Verify that you have all instructional materials related to the chiller. Additional details about troubleshooting and repairing specific components are found in these materials.
- Check that you have manuals for other equipment connected in the system. Troubleshooting may require investigating other equipment attached to, or connected with the chiller.

## A Few Words of Caution

 **WARNING: Improper installation, operation, or servicing may result in equipment damage or personal injury.**

This equipment should only be installed, adjusted, and serviced by qualified technical personnel who are familiar with the construction, operation, and potential hazards of this type of machine.

All wiring, disconnects and fuses should be installed by qualified electrical technicians in accordance with electrical codes in your region.

 **WARNING: Electrical Hazard**

Before performing any work on this item, disconnect and lock out electrical power sources to prevent injury from unexpected energization or startup. Be sure that power to the chiller is OFF when doing any maintenance on the chiller. Follow all safety rules when performing any maintenance on this equipment.

 **WARNING: Refrigerant hazard**

Only certified refrigerant technicians should examine and correct problems involving the refrigerant circuit.

 **CAUTION: Hot Surfaces**

Always protect yourself from hot surfaces when working on the Portable chiller, especially when working on or around the compressor and condenser. These devices can reach up to 160°F {71°C}. Allow these devices to cool before performing any maintenance or troubleshooting.

## Identifying the Cause of a Problem

The Troubleshooting section covers problems directly related to the operation and maintenance of the Portable Chiller. Additional troubleshooting help can be found in the documentation manuals included with this User Guide.

Types of conditions you may see include control problems (not lighting, or lighting and not running), and alarm conditions.

# TIC Control Answering an Alarm

When an alarm condition occurs, the alarm light on the control panel lights. It stays lit until the alarm condition is corrected. If you have the optional audible alarm, pressing the On/Off button silences the audible alarm and stops the chiller. Acknowledge an alarm by pressing the Previous/Next buttons at the same time until alarm clears. In the event that the alarm clears the condition needs to be fixed.

To find out what is causing the alarm, check the indicator lights on the control panel for the pump and compressor status. If the pump and compressor are both off, check the water tank level, flow valves, and the pump. If the pump is on and the compressor is off, check the compressor, suction pressure and discharge pressure.

<b>Alarm Condition</b>	<b>Description</b>	<b>Pump Status</b>	<b>Compressor Status</b>
Flow Fault	There is no flow of the process fluid at the pump discharge. The water level in the pump tank is low.	OFF	OFF
Pump Overload	There is a high amperage condition; the pump is drawing too much current.	OFF	OFF
Compressor Overload	There is a high amperage condition; the compressor is drawing too much current.	ON	OFF
High Discharge Pressure	The refrigerant pressure, as measured at the compressor outlet is high.	ON	OFF
Low Suction Pressure	The refrigerant pressure, as measured at the inlet of the compressor is low.	ON	OFF

Refer to the Troubleshooting tables and the wiring diagrams to correct the alarm condition.

# TIC Control Problems

Look here if the control panel is not lit, or if the power is on and the Portable Chiller will not run.

## Symptom

The control is not lit and the chiller is not working.

## Possible cause

**Power is not reaching the chiller.**

**The correct power is not reaching the unit.**

**There is a problem with the TIC control.**

**There is a problem with the control panel.**

## Solution

- Check the power cord and plug. Make sure the cord and plug are properly connected.
- Make sure the main disconnect switch is on.
- Check fuses and breakers. Replace or reset as required.

Check the voltage specification on the chiller nameplate.

- Check fuses and replace as needed.
- Check the power to the temperature controller. Reconnect or replace as needed.
- Check the TIC indicator lights and replace as needed.

The control panel may have failed. Contact Conair Service.

(continued)

# TIC Control Problems

## Symptom

The control is not lit and there is no alarm condition. The compressor hums, but does not run.

## Possible cause

**The input voltage is incorrect**

**There is a phase loss**

## Solution

- Check the main supply voltage. It must be within 10% of the nameplate rating.
  
- Check the fuses on the main power supply
- Check the phase-to-phase voltages
- Check the phase continuity through the compressor contactor
- Check the wiring at the compressor  
Replace or repair as needed.

# TIC Control Alarm Conditions

Look here when the Alarm/Shutdown light on the control panel is lit. See Answering an Alarm, in the Troubleshooting section before going to these tables.

Alarm	Possible cause	Solution
Deviation from Setpoint Alarm (DtA)		
High Deviation	<b>Load too high for chiller.</b>	Reduce load on chiller; if not able to reduce load, choose a chiller with more capacity.
Low Deviation	<b>Insufficient load for the chiller</b>	The chiller needs to be loaded by at least 25% of the chiller capacity for correct operation; adjust as necessary.
	<b>Low Condenser water temperature or low ambient air temperature. This will create a low discharge pressure</b>	This will create a low discharge pressure which negatively affects the system. Adjust as necessary.

## TIC Control Alarm Conditions (continued)

Alarm	Possible cause	Solution
Low Suction Pressure (pump is running and compressor is off) “PAL”	<b>No or low flow with a failed flow switch and Sensor.</b>	<input type="checkbox"/> Check To Process and From Process valves to see if they are open. <input type="checkbox"/> Check Flow switch and Sensor. Replace as needed.
	<b>Compressor suction valve is closed.</b>	Open valve.
	<b>No load on the Chiller.</b>	Check process for required load. Chiller may be oversized.
	<b>The Evaporator is fouled.</b>	Clean Evaporator. <i>See Cleaning the Evaporator or Water-cooled Condenser, in the Maintenance section.</i>
	<b>The Evaporator is frozen.</b>	<input type="checkbox"/> Check RTD; Replace as needed. <input type="checkbox"/> Check minimum allowable setpoint for percent glycol used.
	<b>There is a refrigerant leak.</b>	Check for oil in chiller cabinet and bubbles in refrigerant site glass. Consult Conair Service for repair.
	<b>The pressure switch is faulty.</b>	<i>See Checking Pressure Switches, in the Troubleshooting section.</i>

## TIC Control Alarm Conditions (continued)

Alarm	Possible cause	Solution
<p>High Discharge Pressure (pump is running, compressor is off) PSH must be manually reset by depressing reset button on top of switch in chiller and acknowledge on face of controller</p>	<b>Clogged/dirty air-cooled condenser.</b>	<p>Clean the air filter or coil. <i>See Cleaning the Air-cooled Condenser, in the Maintenance section.</i></p>
	<b>Blocked air flow to air-cooled condenser.</b>	<p>Move chiller or unblock air passageway.</p>
	<b>Low condenser water flow or water too warm to water-cooled condenser.</b>	<p>Check required flow; <i>see Specifications in the Description section.</i></p>
	<b>Blocked condenser water line or valve closed.</b>	<p>Unblock line; open valve.</p>
	<b>Water-cooled condenser fouled.</b>	<p>Clean the condenser. <i>See Cleaning the Air-cooled Condenser, and Cleaning the Evaporator or Water-cooled Condenser, in the Maintenance section.</i></p>

## TIC Control Alarm Conditions (continued)

Alarm	Possible cause	Solution
High Discharge Pressure, cont'd PSH	<b>Valves were removed.</b>	
	<b>Overcharged with refrigerant.</b>	<i>See Checking the Refrigerant Charge in the Maintenance section.</i>
	<b>Faulty optional water regulating valve.</b>	Repair or replace the valve.
	<b>Faulty pressure switch.</b>	<i>See Checking the Pressure Switches, in the Troubleshooting section.</i>

# TIC Control Alarm Conditions (continued)

## Alarm

Sensor Failure SF2

## Possible cause

**The process temperature sensor failed**

**Sensor wiring is incorrect or failed**

## Solution

Check with OHM meter and see if the resistance matches the table below. Replace if needed.

Check all wiring from terminal strip to sensor in question. Repair as necessary.

°F {°C}	Resistance in Ohms	°F {°C}	Resistance in Ohms
-40 {-40}	613	113 {45}	1195
-31 {-35}	640	122 {50}	1237
-22 {-30}	668	131 {55}	1279
-13 {-25}	697	140 {60}	1323
-4 {-20}	727	149 {65}	1368
5 {-15}	758	158 {70}	1413
14 {-10}	789	167 {75}	1459
23 {-5}	822	176 {80}	1506
32 {0}	855	185 {85}	1554
41 {5}	889	194 {90}	1602
50 {10}	924	203 {95}	1652
59 {15}	960	212 {100}	1702
68 {20}	997	221 {105}	1753
77 {25}	1035	230 {110}	1804
86 {30}	1074	239 {115}	1856
95 {35}	1113	248 {120}	1908
104 {40}	1153	-----	-----

## TIC Control Alarm Conditions (continued)

Alarm	Possible cause	Solution
High Temperature Safety Temp >95°F alarm (tHS)	<b>The hot gas bypass valve is not working properly (possibly stuck open)</b>	Have a certified refrigeration technician replace the solenoid valve.
	<b>Load is too high for the chiller.</b>	Remove some load from the process.
	<b>Fluid is not flowing between the supply outlet and return inlet.</b>	Check for plugged pipes, closed valves, or failed flow switch.
	<b>The compressor is not running.</b>	Check to see if Compressor light is lit on the control. If it is not, check compressor overload in compressor terminal box. Check power to compressor and power to compressor contactor.
	<b>Failed RTD or Temperature Transmitter.</b>	<i>See Checking the Temperature Transmitter and RTD in the Troubleshooting section.</i>

## TIC Control Alarm Conditions (continued)

Alarm	Possible cause	Solution
Flow fault (pump and compressor are off) “FAL”	<b>The optional To Process and/or From Process valves are closed.</b>	Open valve(s).
	<b>The Process Fluid strainer is clogged.</b>	Clean the evaporator strainer.
	<b>Water level in reservoir is low.</b>	Fill the reservoir. <i>See Making Process Plumbing Connections, in the Installation section.</i>
	<b>The evaporator is fouled.</b>	Clean Evaporator. <i>See Cleaning the Evaporator or Water-cooled Condenser, in the Maintenance section.</i>
	<b>Pump is not running.</b>	Check overload module. Replace as needed. <i>See Replacing Overload Modules, in the Troubleshooting section.</i>
	<b>Pump is running backwards.</b>	Switch any two of the three main power leads to the pump.

## TIC Control Alarm Conditions (continued)

Alarm	Possible cause	Solution
Low Temperature Alarm (tAL)	<b>Insufficient load for the chiller</b>	The chiller needs to be loaded by at least 25 % of the chiller capacity for correct operation; adjust as necessary.
	<b>The hot gas bypass valve is not working properly (possibly stuck closed).</b>	If To Process temperature starts to go down and the hotgas valve doesn't open, check power to valve coil. Replace coil if power supplied but valve not opening. Otherwise have a certified refrigeration technician replace the solenoid valve.

# TIC Control Alarm Conditions (continued)

Alarm	Possible cause	Solution
Pump Overload (pump and compressor are off) Must be manually reset in control enclosure.	<b>Overload set incorrectly.</b>	Check table on wiring diagram for correct amperage. Adjust overload accordingly.
	<b>Low supply voltage.</b>	<input type="checkbox"/> Check supply voltage. Supply voltage to contactor should be +/- 10% of nameplate voltage. <input type="checkbox"/> Check wire terminations and connections. Tighten if loose.
	<b>Faulty contactor</b>	Check line and load side of contactor. It should be less than 5 volt drop across the contactor. If it is not, replace the contactor. <i>See Replacing the Contactor in the Troubleshooting section.</i>
	<b>Faulty overload module.</b>	Check amp draw of circuit. If it is under the rated setting, replace the overload module. <i>See Replacing Overload Modules, in the Troubleshooting section.</i>

# PLC Control Answering Alarms

When an alarm condition occurs, the Alarm light on the control panel lights and the control screen displays the alarm message.

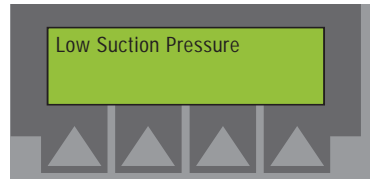

Before an alarm can be reset using the “Alarm Silence/Reset” key (#9 key), the alarm condition must be cleared. The acknowledgement of an alarm is done by pressing and holding the “Alarm Silence/Reset” key (#9 key) for 3 seconds.

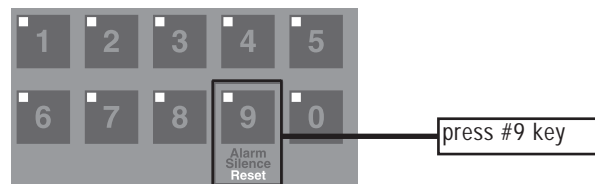

If there is a fault affecting compressor operation such as overload, high or low discharge pressure, compressor fault, etc., there is a three-minute delay before the compressor can be started. The compressor light will flash quickly indicating that manual reset is necessary. The manual reset should be performed only after the alarm condition has been diagnosed and corrected. The manual reset will start the compressor provided all other permissive are enabled. To manually reset the compressor, press the Alarm Silence button and hold for 6 seconds.

To view a list of the last 10 alarms, refer to Alarm History Screens, in the Troubleshooting section of this manual. Alarms are numbered and listed in order of occurrence, starting with the most recent.

# PLC Control Alarm Conditions

Before an alarm can be reset with the acknowledge key, the alarm condition must be cleared. To acknowledge an alarm is press and hold the alarm silence (#9) buton for 3 seconds.

When the temperature falls below the Low Temperature cut out, the compressor shuts off. The Alarm light illuminates and the PLC displays "Low Temperature Cutout". The process or recirculation pump remains running until the Stop button is pressed. For the single pump, this is the To Process temperature. For a dual pump, see Evap Outlet Temp.

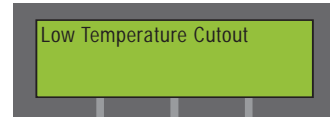

\*requires manual reset

When the To Process Temperature increases to 95°F{35°C} the compressor shuts off. The Alarm light illuminates and the PLC displays "High Temp Safety (Temp>95°F)". The process pump remains running until the Stop button is pressed.

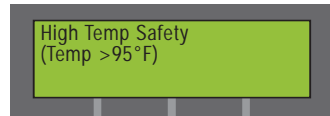

\*requires manual reset

If the temperature rises above the setpoint a high temperature deviation occurs. The degrees Fahrenheit deviation is a variable from 3 to 20, adjustable on a Setup screen. If a high deviation is present the Alarm light illuminates and the PLC displays "High Temperature Deviation". The alarm can be cleared after the temperature drops below the high temperature deviation setpoint or the high deviation is changed to a larger value and the alarm is acknowledged. Acknowledge the alarm by pressing the Stop Chiller button. \* Not recorded in alarm history.



If the flow switch (FS-1) detects a low flow condition, the compressor and process pump will be shut down. The "alarm" light illuminates and the PLC indicates "Flow Fault". The process pump will remain running until the Stop button is pressed. For a dual pump, the Process Pump remains ON.

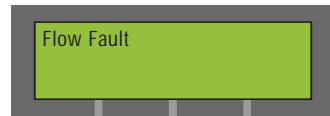

When the refrigerant suction pressure (PT-1) goes below 28 PSIG the compressor will be shut off. The "alarm" light illuminates and the PLC indicates "Low Suction Pressure" for the compressor on a single compressor system and compressor 1 on a dual compressor system. The PLC will indicate "Low Suction Pressure 2" for compressor 2 on a dual compressor system. The process pump will remain running until the Stop button is pressed. (Suction pressure when PT1 goes below 0 psig, leads to sensor failure.)

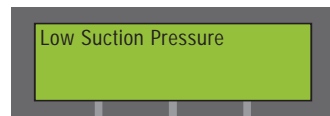

\*requires manual reset

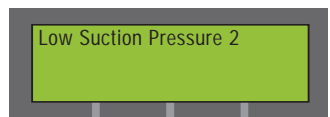

\*requires manual reset

# PLC Control Alarm Conditions

## Continued

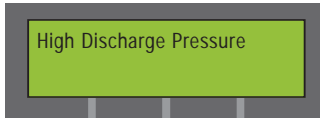

High Discharge Pressure

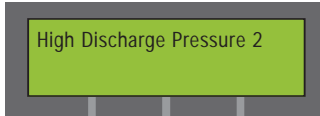

High Discharge Pressure 2

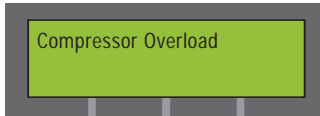

Compressor Overload

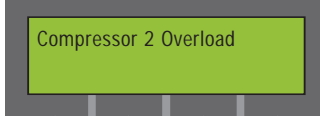

Compressor 2 Overload

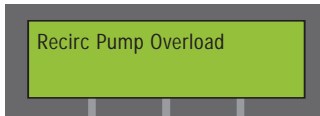

Recirc Pump Overload

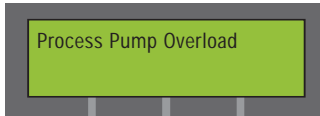

Process Pump Overload

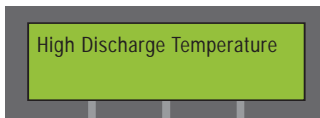

High Discharge Temperature

If refrigerant discharge pressure (PT-2) goes above 290 psig (for water-cooled models) or 350 psig (for air-cooled models) the compressor shuts down. The Alarm light illuminates and the PLC indicates "High Discharge Pressure" for the compressor on a single compressor system and compressor 1 on a dual compressor system. The PLC will indicate "High Discharge Pressure 2" for compressor 2 on a dual compressor system. The process pump will remain running until the Stop button is pressed.

If the compressor overloads and trips the MSP, the compressor shuts down. The Alarm light illuminates and PLC indicates "Compressor Overload" for the compressor on a single compressor system and compressor 1 on a dual compressor system. The PLC indicates "Compressor 2 Overload" for compressor 2 on a dual compressor system. The MSP must be reset inside the control panel. The process pump remains running until the Stop button is pressed.

If the process or optional recirculation pump overloads and trips the MSP, the compressor and pump(s) shut down. The MSP must be reset inside the control panel. The Alarm light illuminates and PLC indicates "Pump Overload" for a process pump overload.

The 3.5 and 5 hp compressors (used on PCW-3, PCW-5, PCA-3 and PCA-5) have a high discharge refrigerant temperature switch (TSHH-1). If the switch detects a high discharge temperature the compressor shuts off immediately. The alarm light illuminates and the PLC indicates "High Discharge Temperature". The process pump remains running until the Stop button is pressed.

# PLC Control Alarm Conditions

## Continued

The 7.5 HP and larger compressors have a High Temperature Protector Module to protect the compressor from high internal temperatures, overcurrent conditions and phase imbalance. On single compressor systems (and dual compressor systems with only one compressor enabled), when the normally closed contact opens, it shuts off the compressor immediately and the contact remains open for 30 minutes. The PLC indicates "Compressor Fault" on single compressor systems and or compressor 1 on dual compressor systems. A fault on compressor 2 on a dual compressor system displays "Compressor 2 Fault". When the contact closes and the fault is acknowledged, the compressor will restart. On dual compressor units, if the lead compressor's Protector Module contact opens, the lag compressor becomes the lead compressor and the alarm is displayed. When the 30-minute delay has expired and the alarm is acknowledged, the compressor that had faulted remains the lag compressor. If the lag compressor's Protector Module contact opens, the compressor shuts off and the alarm is initiated. This alarm can be cleared after the 30-minute delay and the alarm is acknowledged. In the event compressor rotation is phased wrong, the unit will have to be powered down, reverse phase of any two leads at compressor contractor. Reapply power.

To clear the alarm(s) press and hold the Silence button for three seconds. To start the chiller once the 3-minute compressor down time has expired, press the Run button on the Run Screen.

The alarms are logged in an alarm history table. The last 10 alarms (except the high temp deviation alarm) are recorded and display on the Alarm screen, along with the alarm number, all temperatures and refrigerant pressure.

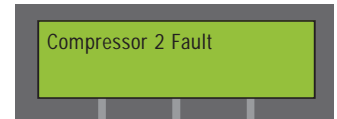
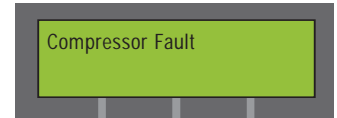

# PLC Control Alarm Errors

Alarm Message	Description
Flow Fault	There is low process fluid flow at the pump discharge.
Low Suction Pressure	The refrigerant pressure, measured at the inlet of compressor 1, is low.
High Discharge Pressure	The refrigerant pressure, measured at the outlet of compressor 1, is high.
Process Pump Overload	High amperage condition; the pump is drawing too much current.
High Temperature Safety Temp >95°F	The To Process fluid temperature is above 95°F, measured at the evaporator outlet.
Low Temperature Cutout	If the To Process fluid temperature falls 5° below the minimum setpoint (measured at the evaporator outlet) the compressor shuts off to allow the temperature to rise.
Compressor Overload	High amperage condition; compressor 1 is drawing too much current.
High Temperature Temperature >75°F for 5 min	To Process fluid temperature is above 75°F (measured at the evaporator outlet) after the compressor has been running for five minutes at startup.
High Discharge Pressure 2	The refrigerant pressure, measured at compressor 2 outlet, is high.
Low Suction Pressure 2	The refrigerant pressure, measured at compressor 2 inlet, is low.
Compressor 2 Overload	High amperage condition; compressor 2 is drawing too much current.
Compressor 2 Fault	Compressor 2 is wired incorrectly. Two of the lead wires need to be switched.
Fan Overload	High amperage condition; the fan motor is drawing too much current.
Discharge Pressure Sensor Failure	The sensor is incorrectly reading discharge pressure below -15 or above 500.
Discharge Pressure Sensor Fault 2	Sensor 2 is incorrectly reading discharge pressure below -15 or above 500.
Fan VFD Alarm	The optional variable frequency drive on the fan failed.
Recirc Pump Overload	High amperage condition; the optional recirculation pump is drawing too much current.
Loss of Control Power	This occurs when the 24VDC power to Input 1.5 is low. Check Fuse 4.
Suction Pressure Sensor Failure	This occurs when pressure is below 0 psig or about 300 psig.
Suction Pressure Sensor Failure 2	Same as above.

# PLC Control Alarm History Screens

The alarm history screens display the last 10 alarms that have occurred. They are listed in the order of newest to oldest. Scroll through the alarm history screens by pressing the scroll arrows. The Next arrow takes you back in time. The alarm screen displays the alarm number (1-10) and an alarm description. Pressing the Select Option arrows allows the operator to view the pressures and temperatures at time of the alarm.

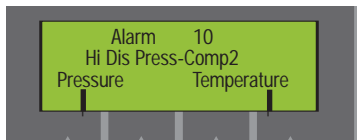

When Pressure is selected discharge pressure information at the time of the alarm displays.

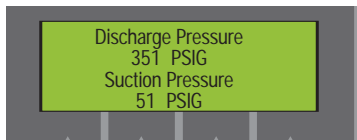

Pressing the Escape key returns to the main menu. Pressing the Next arrow displays the suction pressure at time of the alarm.

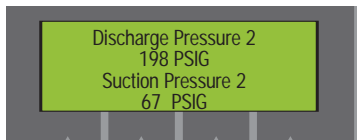

Dual Pump  
Only

For dual compressor units, the suction and discharge pressures at time of alarm of the second compressor are also captured. These can be viewed by pressing the scroll arrows.

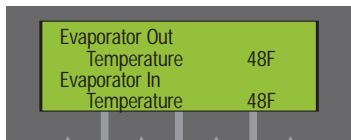
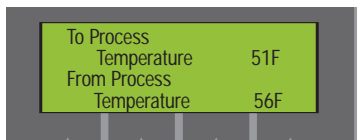

Dual Pump  
Only

When Temp is selected from the alarm screen, the To and From Process Temperature at the time of the alarm displays. Pressing the RET select option key returns to the alarm.

Pressing the Next arrow displays Evap In and Out (dual pump only) at the time of the alarm. Scroll through the four temperature values by pressing the Prev and Next arrows. Press Previous multiple times to return to the main screen.

# PLC Control Alarm Screen Legend

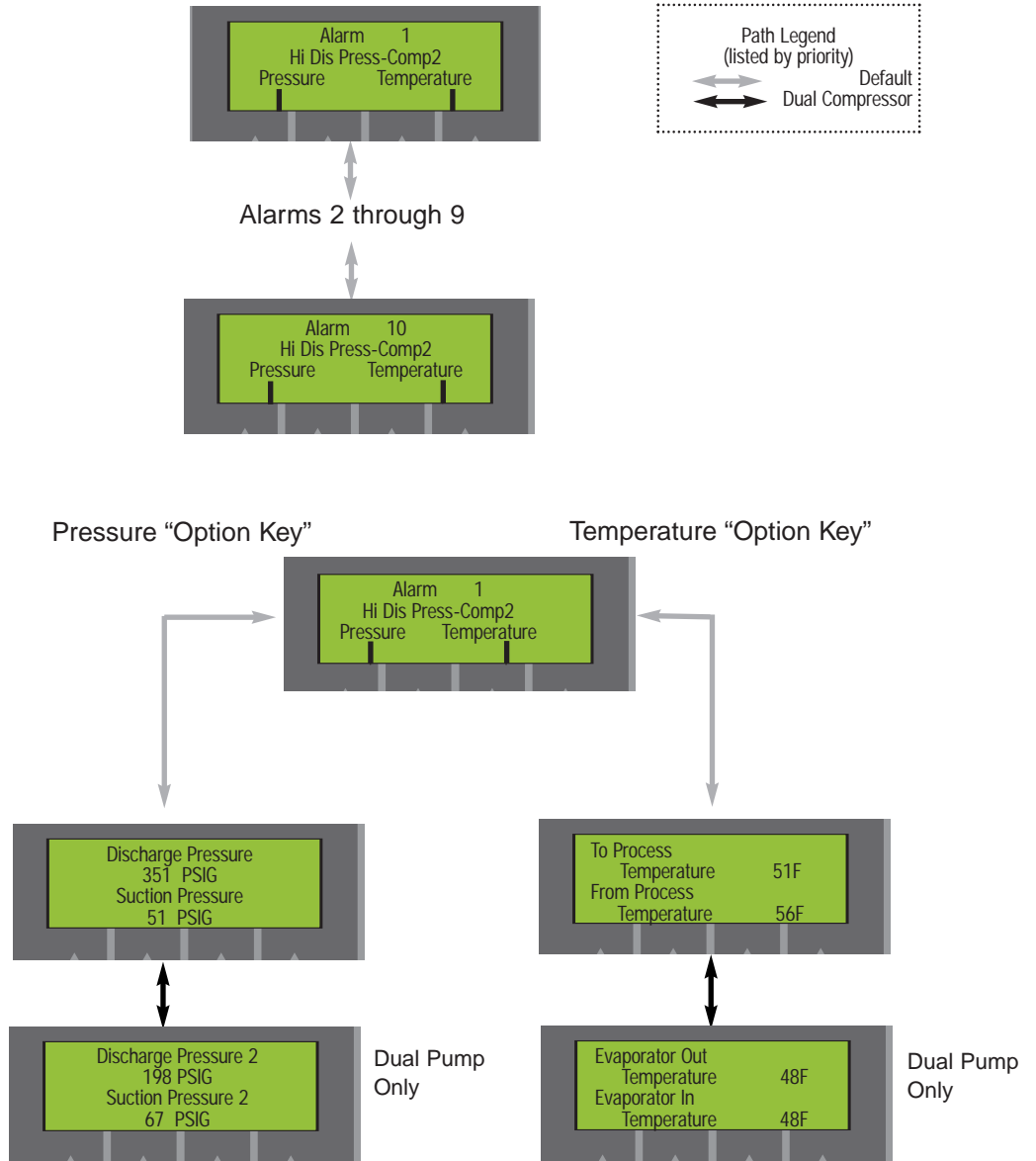

# PLC Control Problems

SEE DI/DO screen in Maintenance menu for PLC Troubleshooting.

## Symptom

The control is not lit and the chiller is not working.

## Possible cause

**Power is not reaching the chiller.**

**The correct power is not reaching the unit.**

**There is a problem with the PLC.**

**There is a problem with the control panel.**

## Solution

- Check the power cord and plug. Make sure the cord and plug are properly connected.
- Make sure the main disconnect switch is on.
- Check fuses and breakers. Replace or reset as required. *See Replacing Fuses, in the Troubleshooting section.*

Check the voltage specification on the chiller nameplate.

- Check fuses and replace as needed. See Replacing Fuses, in the Troubleshooting section.
- Check the cable between the control panel and the PLC; reconnect or replace as needed.
- Check the PLC indicator lights: Power and Program Run lights should be lit. Contact Conair Service if status is not normal.

The control panel may have failed. Contact Conair Service.

## PLC Control Problems Continued

### Symptom

The control is lit and there is no alarm condition. The compressor hums, but does not run.

### Possible cause

**The input voltage is incorrect**

**There is a phase loss**

### Solution

Check the main supply voltage. It must be within 10% of the nameplate rating.

- Check the fuses on the main power supply. Replace or reset as required. *See Replacing Fuses, in the Troubleshooting section.*
- Check the phase-to-phase voltages
- Check the phase continuity through the compressor contactor
- Check the wiring at the compressor

# PLC Control Alarm Problems

## Alarm

Flow Fault alarm

## Possible cause

## Solution

**The optional To Process and From Process valves are closed.**

Open valve(s).

**Piping has no Flow Potential**

Verify that flow is evident for application. Add bypass valve if needed to process piping.

**The Process fluid strainer is clogged.**

Clean the strainer.

**Water level in reservoir is low and float switch failed.**

Fill the reservoir. *See Making Process Plumbing Connections, in the Installation section.*

**IF CHILLER HAS AUTO-FILL OPTION:**

**Solenoid valve faulty**

Check level gauge and compare it to status of the level switch in electrical enclosure. Refer to wiring diagrams. Clean switch; replace as needed.

**Water supply valve closed**

Open Supply valve.

**Input wiring to PLC incorrect.**

Check wiring diagrams and compare to wiring to PLC; correct as needed.

# PLC Control Alarm Conditions

Alarm	Possible cause	Solution
Flow Fault alarm (cont'd.)	<b>The evaporator is fouled.</b>	Clean Evaporator. <i>See Cleaning the Evaporator or Water-cooled Condenser, in the Maintenance section.</i>
	<b>Pump is not running.</b>	Check the overload module. Reset or replace as needed. <i>See Replacing Overload Modules, in the Troubleshooting section.</i>
	<b>Pump is running backwards; no pump pressure is indicated on pump discharge pressure gauge.</b>	Switch any two of the three main power leads. <i>See Testing Pump Performance.</i>
	<b>Evaporator is frozen.</b>	Apply warm air to the evaporator to thaw or leave unit off for extended period of time.  Dual Pump only: Recirculation valve at pump discharge is closed or needs to be opened.

# PLC Control Alarm Conditions

## Symptom

Low Suction Pressure alarm

OR

Low Suction Pressure 2 alarm  
(28 psig cutout valve)

## Possible cause

**No or low flow with a failed flow switch and RTD.**

**The Evaporator is fouled.**

**Evaporator frozen.**

**Faulty TXV solenoid or Relay.**

**Refrigerant leak.**

**Faulty pressure transducer.**

**Condenser air or water too cold.**

**Wiring incorrect.**

## Solution

Check optional To Process and From Process valves to see if they are open. Check Flow switch and RTD. Replace as needed.

Clean Evaporator. *See Cleaning the Evaporator or Water-cooled Condenser, in the Maintenance section.*

- Check flow switch, RTD, temperature transmitter and low temperature cutout on temperature controller. Replace as needed.
- Check PLC control for proper percent ethylene glycol or propylene glycol solution. Change percent glycol setpoint, if needed. Add glycol if needed.
- Dual pump only: recirculation valve at pump discharge is closed or needs to be opened.

Check wiring, voltage, coil and relay (see electrical drawings); replace as needed.

Check for oil in chiller cabinet and bubbles in refrigerant sight glass. Consult Conair Service for repair.

*See Checking the Pressure Transducer, in the Troubleshooting section or appendix.*

Check air/water temperature. Water should be 75°F or higher; air temperature should be 70°F or higher. *See spec sheet.*

Use wiring diagrams and check wiring. Correct as needed.

# PLC Control Alarm Conditions

## Alarm

High Discharge Pressure alarm  
OR

High Discharge Pressure 2  
alarm (cutout 350 psig air 290  
psig water-cooled condenser)



**NOTE:** On (air-cooled units) upper panels must be on when the compressor is running or this fault will occur.

## Possible cause

**Clogged/dirty air-cooled condenser or filter.**

**Blocked air flow to air-cooled condenser.**

**Low condenser water flow or water too warm to water-cooled condenser.**

**Blocked condenser water line or valve closed.**

**Condenser fouled.**

**Fan motor not running. [fan setting - cut in 250, cut out 190, DPS set point 225 (VFD only)]**

**Faulty liquid line solenoid valve (TXV).**

**Overcharged with refrigerant.**

**Faulty optional water regulating valve.**

**Faulty pressure transducer.**

**Input wiring to PLC incorrect.**

**If recently serviced, non-condensibles in refrigerant system.**

## Solution

Clean the filter or coil. *See Cleaning the Air-cooled Condenser, in the Maintenance section.*

Move chiller or unblock air passageway. *See installation section.*

Check required flow; *see Specifications in the Description section.* Verify condenser water pump is on (customer supplied). *See How to Set WRV properly*

Unblock line; open valve. Check and clean filter strainer.

Clean the condenser. *See Cleaning the Air-cooled Condenser, and Cleaning the Evaporator or Water-cooled Condenser, in the Maintenance section.*

Check fan cycling operation settings. Motor may be bad. See Drive manual electrical information accompanying this user guide. *See PLC setting Fan Setpoints OR setting DPS Setpoint (VFD only)*

Check voltage. Replace valve as needed.

*See spec sheet data refrigerant charge chart.*

Repair or replace the valve.

*See Checking the Pressure Transducer, in the Troubleshooting section.*

Check wiring diagrams and compare to wiring to PLC; correct as needed.

Notify refrigerant service technician to troubleshoot.

# PLC Control Alarm Conditions

## Alarm

Comp Fault alarm

OR

Compressor 2 comp Fault  
(dual pump models)

## Possible cause

**Compressor is wired incorrectly.**

**Compressor module is faulty.**

**Loss of 120 VAC to module.**

## Solution

Shut off chiller supply voltage. Switch any two leads:

- at compressor if it was replaced.
- at main terminal block if new unit installation.

Turn chiller on.

*See Checking the Compressor module spec's in the Troubleshooting section.*

Check power to T1 and T2 Term on module. *See compressor module.*

# PLC Control Alarm Conditions

Alarm	Possible cause	Solution
Process Pump Overload alarm  OR  Recirculation pump overload (dual pump option only)	<b>Motor starter protector (MSP) set incorrectly.</b>	Check data tag in Electrical Cabinet. Adjust overload accordingly. SEE adjusting/Replacing MSP modules in T5 section. See How to properly set MSP before replacing.
	<b>Low supply voltage</b>	<input type="checkbox"/> Check supply voltage. Supply voltage to contactor should be +/- 10% of nameplate voltage. <input type="checkbox"/> Check wire terminations and connections at pump MSP contactor and motor. Tighten if loose.
	<b>Faulty contactor.</b>	Check voltage between line and load side of contactor. It should be less than 5 volt drop across the contactor. If it is not, replace the contactor. See <i>Adjusting/Replacing the Contactor in the MSP Troubleshooting section.</i>
	<b>Faulty MSP.</b>	Check amp draw of circuit. If it is under the rated setting, replace the MSP. See <i>Adjusting/Replacing MSP Modules, in the Troubleshooting section.</i>
	<b>Control voltage is incorrect.</b>	24VDC required for contactor auxiliary input. If control voltage is OK replace PLC.

# PLC Control Alarm Conditions

## Alarm

High Temperature  
Safety Temp > 95F alarm

Based on To Process  
Temperature, but If Dual Pump  
then Evaporator outlet  
Temperature.

## Possible cause

**The hot gas bypass valve is not working properly (possibly stuck open)**

**Load is too high for the chiller.**

**Fluid is not flowing between the supply outlet and return inlet.**

**The compressor is not running.**

**Failed RTD or Temperature Transmitter.**

## Solution

Have a certified refrigeration technician replace the solenoid valve.

Remove some load from the process. For quickest recovery drain reservoir and refill with water below 75° F. Otherwise, remove load and allow water to only flow between to and from process and bypass process piping.

Check for plugged pipes, closed valves, or failed flow switch.

Check to see if Compressor light is lit on the control. If it is not, check compressor MSP in electric panel. Check power to compressor and power to compressor contactor. Reference alarm menu and verify compressor light illuminates when power is cycled OFF to ON.

*See Checking the Temperature Transmitter and RTD in the Troubleshooting section.*

# PLC Control Alarm Conditions

## Alarm

Low Temperature Cutout alarm

Based on To Process Temperature, but if Dual Pump then evaporator outlet Temperature.



**NOTE:** If the setpoint is changed to a higher value while unit is in Run mode the Chiller will try to raise to setpoint for 5 minutes, therefore the compressor will not cycle off at 4°F below setpoint.

## Possible cause

**Insufficient load for the Chiller.**

**The hot gas bypass valve is not working properly (possibly stuck closed).**

**Failed RTD or Temperature Transmitter.**

**Hot Gas Bypass valve relay failed.**

## Solution

The Chiller needs to be loaded by at least 25% of the Chiller capacity for correct operation, adjust as necessary.

If the To Process or outlet Evaporator (Dual Pump) temperature starts to go down, and the hotgas valve doesn't open, then check power to valve coil. Replace coil if power supplied and valve not opening. Otherwise, the solenoid valve is faulty. Have a certified refrigeration technician replace the solenoid valve.

*See Checking the Temperature Transmitter and RTD, in the Troubleshooting section.*

Replace as needed (see electrical drawings.) 24 VAC will illuminate Relay LED as well as Relay coil. When LED is lit check for 120 VAC to valve coil. Replace relay if no power to coil.

# PLC Control Alarm Conditions

## Alarm

Compressor Overload alarm or  
Compressor 2 Overload alarm

## Possible cause

**MSP set incorrectly.**

**Low supply voltage.**

**Faulty contactor**

**Faulty MSP**

## Solution

Check table on wiring diagram for correct rated load amperage (RLA) draw. Adjust MSP accordingly. *See Adjusting/Replacing MSP* in Troubleshooting.

- Check supply voltage. Supply voltage to contactor should be +/- 10% of nameplate voltage.
- Check wire terminations and connections. Tighten if loose.

Check line and load side of contactor. It should be less than 5 volt drop across the contactor. If it is not, replace the contactor. *See Replacing the Contactor* in the Troubleshooting section.

Check amp draw of circuit. If it is under the rated setting, replace the MSP. *See Adjusting/Replacing the MSP*, in the Troubleshooting section.

# PLC Control Alarm Conditions

## Alarm

High Temperature ( $T > 75^{\circ}\text{F}$  for 5 minutes) alarm.

High Discharge Temperature alarm (3 and 5 HP models with scroll compressors only)

## Possible cause

**Load too high for chiller.**

**The hot gas bypass valve is not working properly (possibly stuck open).**

**Refrigeration circuit not working properly.**

**Compressor malfunctioned.**

**Refrigeration charge low.**

**Temperature sensor is faulty (for 3 and 5 Hp models only).**

## Solution

Reduce load on chiller; if not able to reduce load, choose a chiller with more capacity.

Have a certified refrigeration technician replace the solenoid valve.

- Check refrigerant circuit. *See Checking Refrigerant Charge*, in the Installation section.
- Perform preventative maintenance on chiller evaporator and condenser.

Check voltage to compressor. Check contact points on contactor. Replace if needed.

- Check temperature on suction line; it should be less than  $60^{\circ}\text{F}$ . Check refrigerant sight glass for bubbles. Charge with refrigerant if needed.
- See Checking Refrigerant Charge in Installation.*

Replace temperature sensor mounted on the discharge side of the compressor (trip point is  $260^{\circ}\text{F}$ ).

# PLC Control Alarm Conditions

## Alarm

Fan Overload alarm

## Possible cause

**Fan Access door is open.**

**Motor Starter Protector (MSP) switch has been manually shut off.**

**Motor Starter Protector (MSP) set incorrectly.**

**Low supply voltage.**

**Faulty contactor**

**Faulty Motor Starter Protector (MSP).**

**Control voltage is incorrect.**

## Solution

This will cause too much air flow.  
Close access door.

Reset Motor Starter Protector (MSP) switch.

Check fan motor data tag for correct full load amperage (FLA) draw. Adjust Motor Starter Protector (MSP) accordingly. *See Adjusting/Replacing the Motor Starter Protector (MSP) in Troubleshooting.*

- Check supply voltage. Supply voltage to contactor should be  $\pm 10\%$  of nameplate voltage.
- Check wire terminations and connections. Tighten if loose.

Check line and load side of contactor. It should be less than 5 volt drop across the contactor. If it is not, replace the contactor. *See Replacing the Contactor in the Troubleshooting section.*

Check amp draw of circuit. If it is under the rated setting, replace the Motor Starter Protector (MSP). *See Adjusting/Replacing Motor Starter Protector (MSP) in the Troubleshooting section.*

Check 24VDC required for contactor auxiliary input. If control voltage is OK replace PLC.

# PLC Control Alarm Conditions

Alarm	Possible cause	Solution
Discharge Pressure Sensor Failure alarm	<b>Wiring bad.</b>	Check wiring; correct as needed.
OR		
Discharge Pressure Sensor Failure 2 alarm	<b>There is RF interference.</b>	Check for any electromagnetic interference (for example, from radios). Remove any objects causing the problem.
OR		
Suction Pressure Sensor Failure alarm	<b>The sensor has been damaged.</b>	Check discharge pressure status. <i>See Checking the Pressure Transducer, in the Troubleshooting or Appendix section.</i> Repair or replace the sensor.
OR		
Suction Pressure Sensor Failure 2 alarm.	<b>Loss of control power.</b>	Check fuse supplying 24VDC to PLC inputs. <i>See wiring for “Fuse OK” input.</i>

# Checking and Replacing Switches



## **WARNING: Electrical hazard**

Before performing any work on this unit, disconnect and lock out electrical power sources to prevent injury from unexpected energization or startup.

There is a flow switch in the process fluid line to verify flow.

To check the flow switch:

- 1 Disconnect and lockout power to the chiller.**
- 2 Open the electrical enclosure and locate the connection for the correct switch on the terminal strip.** Refer to the wiring diagrams you received with your chiller to find the correct terminals.
- 3 Check the switch.** Check continuity within the switch and make sure it corresponds to the condition of the switch. Clean the switch if needed.
- 4 Replace the switch as needed.** Drain the tank to replace the switch.



**NOTE:** Always refer to the wiring diagrams that came with your chiller to locate specific electrical components.

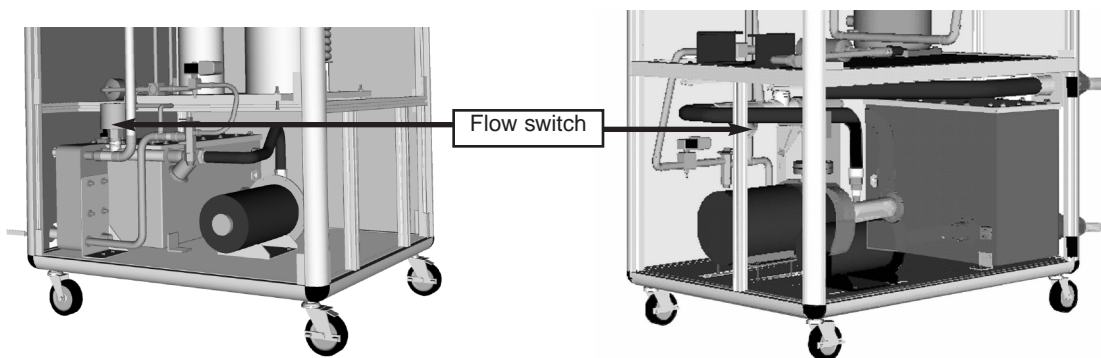

# Replacing the RTD PLC Only

**NOTE:** These connections may vary depending on the model you have purchased. Be sure to see the labeling on your particular unit.

To replace the RTD:

- 1 Disconnect and lockout power to the chiller.**
- 2 Disconnect the To Process tubing from the To Process connection.**

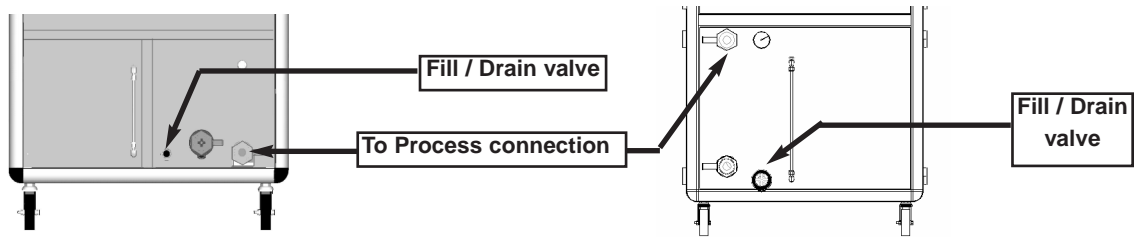

**NOTE:** Always refer to the wiring diagrams that came with your chiller to locate specific electrical components.

- 3 Open the Drain/Fill valve and drain water from the unit so the water level is lower than the RTD.**
- 4 Open the side of the chiller.**
- 5 Disconnect the RTD wiring from the transmitter electrical box. Refer to the wiring diagram.**
- 6 Remove the RTD. Loosen the compression nut to slide the RTD out of the evaporator.**
- 7 Install the new RTD. The new RTD should be inserted in the evaporator so that the tip is extended completely through the evaporator.**
- 8 Wire the RTD to the temperature transmitter to the TIC control in the top electrical enclosure, or to the temperature transmitter (PLC control) and the electrical box.**

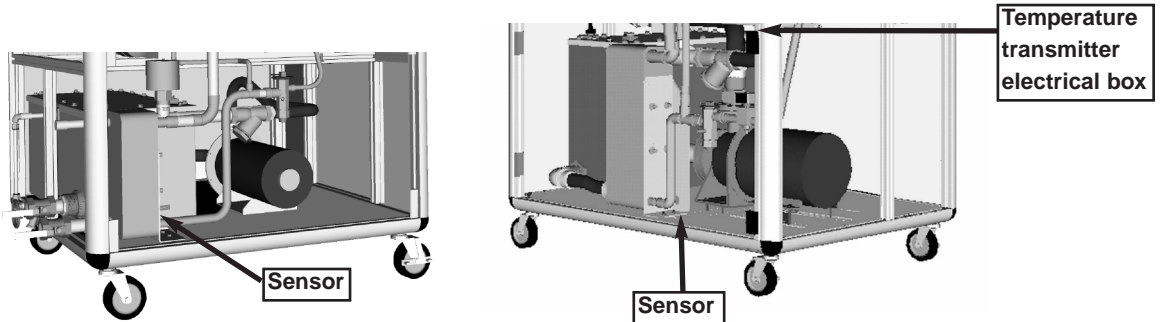

# Removing Pump Components

The pump's wet end (impeller, motor, and seal assembly) can be removed for service.

- 1 Disconnect and lockout power to chiller.**
- 2 Open the drain/fill valve and drain the water from the chiller.**

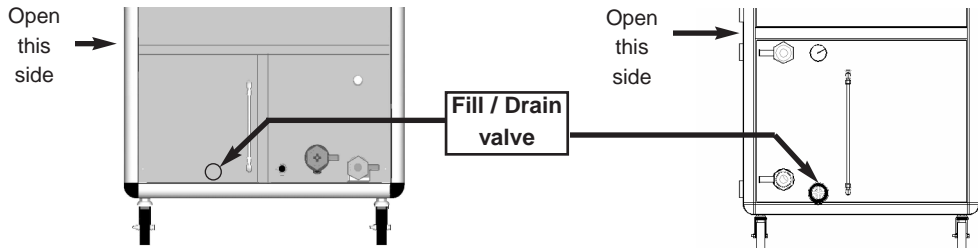

- 3 Open the side of the chiller.**
- 4 Remove the bolts connecting the pump motor to the pump base.**
- 5 Remove the pump volute bolts.**
- 6 Inspect, clean, and replace pump parts as needed.** Separate the pump assembly from the pump volute (casing) by prying the flanges and pulling apart. Follow the disassembly and reassembly procedures in the pump manufacturer's manual that accompanies this User Guide.

 **NOTE:** These connections may vary depending on the model you have purchased. Be sure to see the labeling on your particular unit.

# Replacing Fuses



## WARNING: Electrical hazard

Before performing any work on this unit, disconnect and lock out electrical power sources to prevent injury from unexpected energization or startup.

Always refer to the wiring diagrams that came with your chiller to locate specific electrical components.

To replace fuses:

- 1 Disconnect and lockout power to the chiller.**
- 2 Open the electrical enclosure and locate the fuses.** Refer to the wiring diagram for the exact location.
- 3 Remove and replace fuses.**
- 4 Restore power to the chiller.**

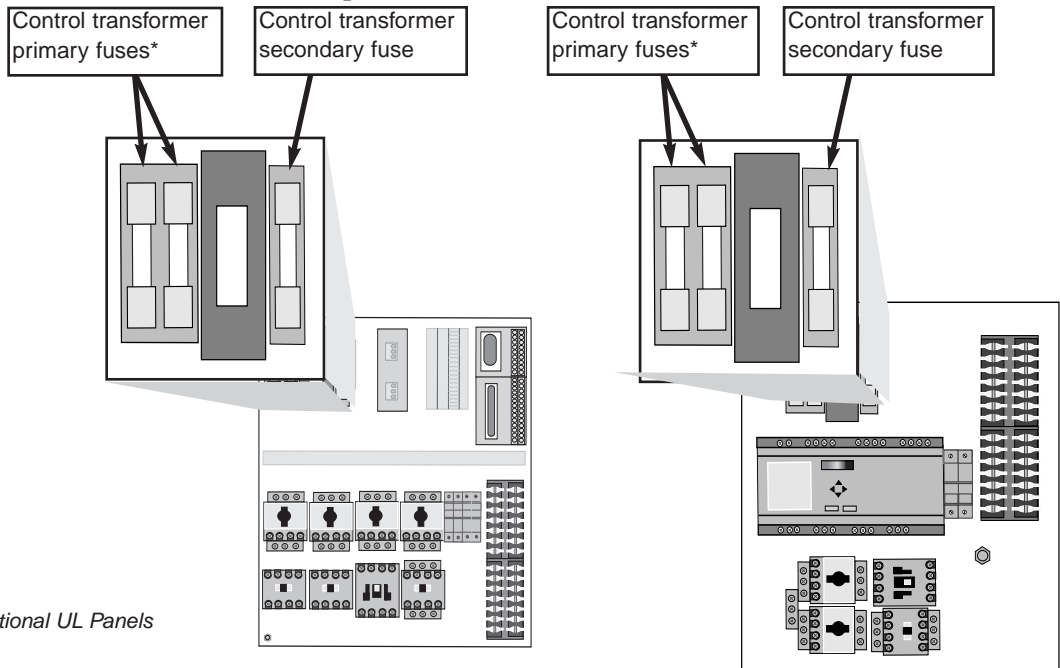

# Replacing the Contactor



## WARNING: Electrical hazard

Before performing any work on this unit, disconnect and lock out electrical power sources to prevent injury from unexpected energization or startup.



**NOTE:** Always refer to the wiring diagrams that came with your chiller to locate specific electrical components.

To replace contactor for the pump, compressor or fan:

- 1 Disconnect and lockout power to the chiller.**
- 2 Open the electrical enclosure and locate the correct contactor.** Refer to the wiring diagrams you received with your chiller.
- 3 Disconnect the wiring from the contactor.** Make sure you label each wire so you can correctly install the new contactor.
- 4 Remove the contactor by snapping off the DIN rail mounting.** Press top of contactor downward and tip bottom toward you.
- 5 Snap in the new contactor on the DIN rail.**
- 6 Reconnect the wiring and reconnect power to the chiller.**
- 7 Test installation by running the chiller.**

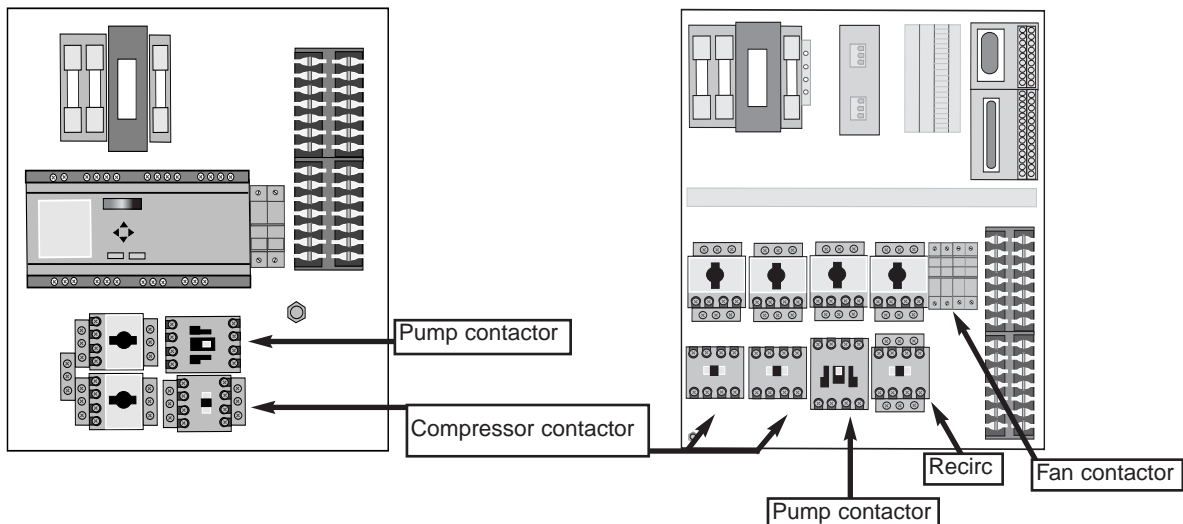



# We're Here to Help

Conair has made the largest investment in customer support in the plastics industry. Our service experts are available to help with any problem you might have installing and operating your equipment. Your Conair sales representative also can help analyze the nature of your problem, assuring that it did not result from misapplication or improper use.

## How to Contact Customer Service

To contact Customer Service personnel, call:



 **NOTE:** Normal operation hours are 8:00 AM - 5:00 PM.  
After hours emergency service is available at the same phone number.

You can commission Conair service personnel to provide on-site service by contacting the Customer Service Department. Standard rates include an on-site hourly rate, with a one-day minimum plus expenses.

## Before You Call...

**If you do have a problem, please complete the following checklist before calling Conair:**

- Make sure you have all model, serial and parts list numbers for your particular equipment. Service personnel will need this information to assist you.
- Make sure power is supplied to the equipment.
- Make sure that all connectors and wires within and between control systems and related components have been installed correctly.
- Check the troubleshooting guide of this manual for a solution.
- Thoroughly examine the instruction manual(s) for associated equipment, especially controls. Each manual may have its own troubleshooting guide to help you.
- Check that the equipment has been operated as described in this manual.
- Check accompanying schematic drawings for information on special considerations.

Additional manuals and prints for your Conair equipment may be ordered through the Customer Service or Parts Departments for a nominal fee.

# Equipment Guarantee

Conair guarantees the machinery and equipment on this order, for a period as defined in the quotation from date of shipment, against defects in material and workmanship under the normal use and service for which it was recommended (except for parts that are typically replaced after normal usage, such as filters, liner plates, etc.). Conair's guarantee is limited to replacing, at our option, the part or parts determined by us to be defective after examination. The customer assumes the cost of transportation of the part or parts to and from the factory.

# Performance Warranty

Conair warrants that this equipment will perform at or above the ratings stated in specific quotations covering the equipment or as detailed in engineering specifications, provided the equipment is applied, installed, operated and maintained in the recommended manner as outlined in our quotation or specifications.

Should performance not meet warranted levels, Conair at its discretion will exercise one of the following options:

- Inspect the equipment and perform alterations or adjustments to satisfy performance claims. (Charges for such inspections and corrections will be waived unless failure to meet warranty is due to misapplication, improper installation, poor maintenance practices or improper operation.)
- Replace the original equipment with other Conair equipment that will meet original performance claims at no extra cost to the customer.
- Refund the invoiced cost to the customer. Credit is subject to prior notice by the customer at which time a Return Goods Authorization Number (RGA) will be issued by Conair's Service Department. Returned equipment must be well crated and in proper operating condition, including all parts. Returns must be prepaid.

Purchaser must notify Conair in writing of any claim and provide a customer receipt and other evidence that a claim is being made.

# Warranty Limitations

**Except for the Equipment Guarantee and Performance Warranty stated above, Conair disclaims all other warranties with respect to the equipment, express or implied, arising by operation of law, course of dealing, usage of trade or otherwise, including but not limited to the implied warranties of merchantability and fitness for a particular purpose.**

# Maintenance Log

Date	Reading							
<b>Maintenance Item</b>								
Compressor 1 Amps, 100% loaded								
Compressor 2 Amps, 100% loaded								
Discharge Pressure 1								
Discharge Pressure 2								
Suction pressure 1								
Suction pressure 2								
Evaporator water out/inlet temperature								
Process Water Pressure								
Condenser 1 Water Temperature, In/Out								
Condenser 2 Water Temperature, In/Out								
Condenser Water Pressure, In/Out								
Condenser 1 Fan Amps								
Condenser 2 Fan Amps								
Condenser 3 Fan Amps								
Condenser 4 Fan Amps								
Process Pump Amps								
Recirculation Pump Amps								
Unit Volts Primary Secondary								
Condenser Air Temp In								
Condenser Air Temp Out								
Oil Level								
Super Heat								
Temperature Setpoint								
RTD Temperatures (4)								
To Process Temperature								
From Process Temperature								
% EG Value								



# Pressure Tables

## Evaporator and Piping Pressure Drops

Size 1

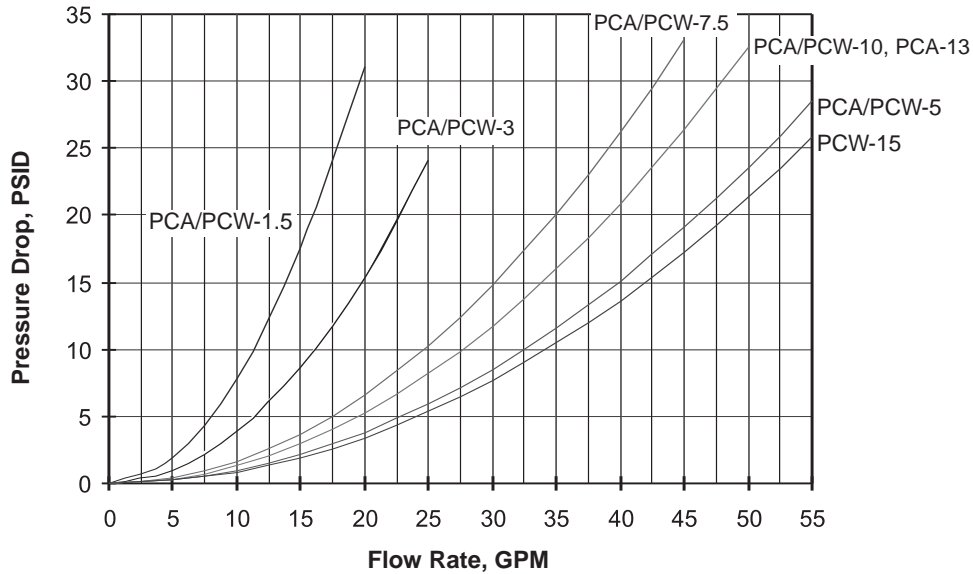

Size 2

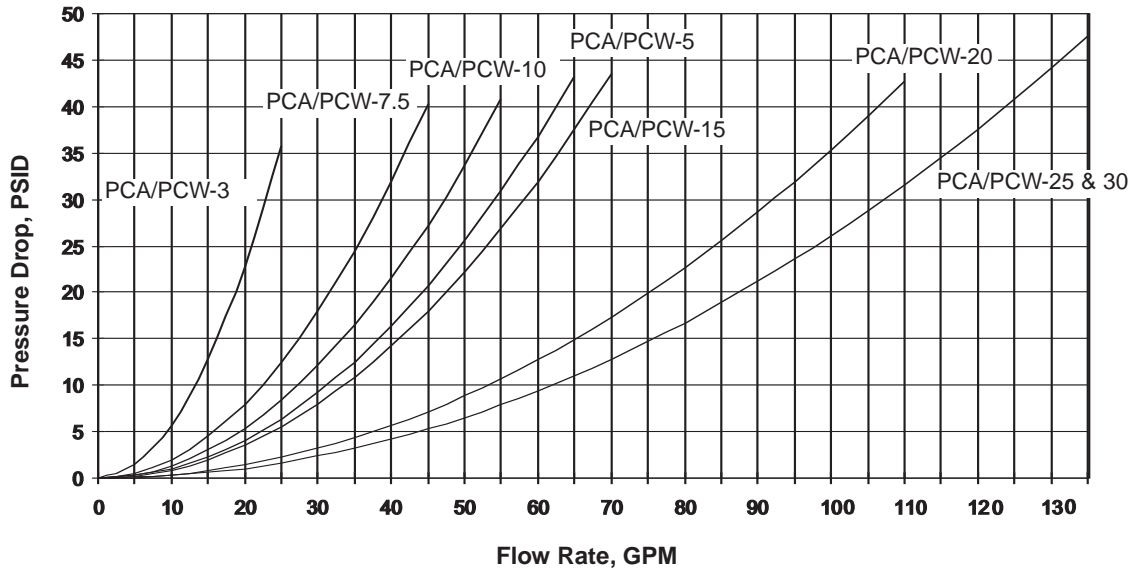

# Pressure Tables

## Condenser and Piping Pressure Drops

Size 1

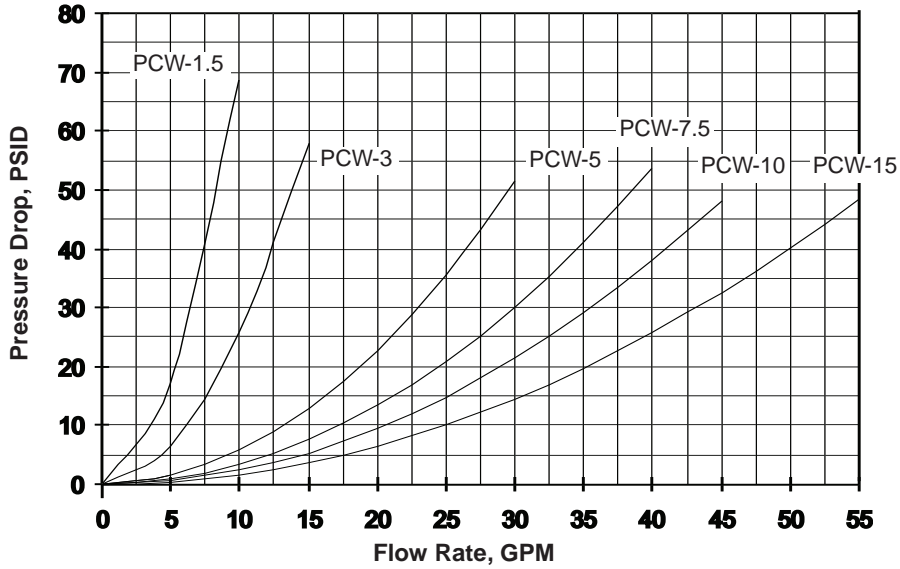

Size 2

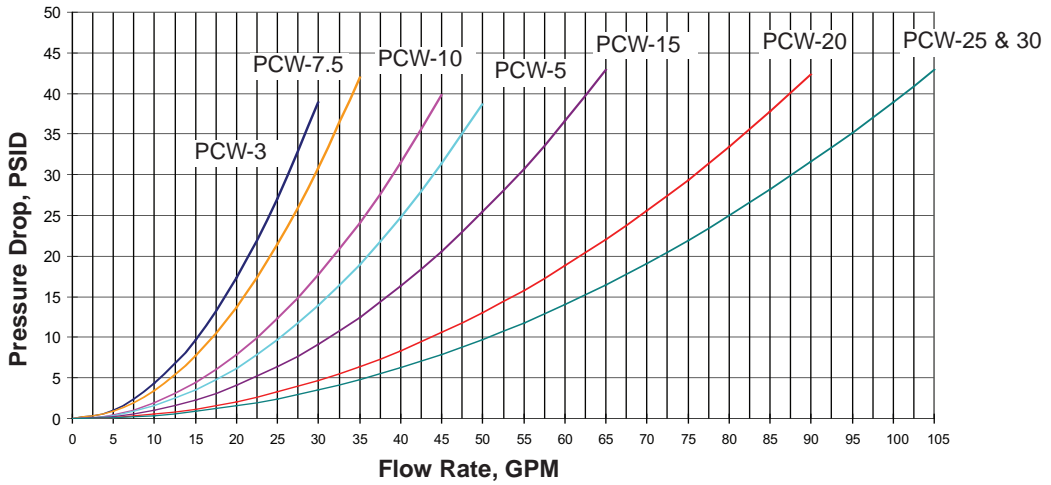

# Overhead Plumbing Details

Overhead piping installations above process connections require installing a check valve in the To Process line and a 12 inch {305 mm} riser with check valve and vacuum break in the From Process line to prevent siphoning when shutting down. Install a vent tube to 12 inches {305 mm} above the highest system point to prevent over-pressurization. Maximum height of piping above process connections is 25 ft {7.6 m}.

