

User Guide

MXR Sprue Pickers with CD-EM1 control

Models MXR-60 and MXR-150

Installation

Operation

Maintenance

Troubleshooting



*Instant Access
Parts and Service
(800) 458-1960
(814) 437-6861*

www.conairnet.com

CONAIR™

The Conair Group, Inc.
One Conair Drive
Pittsburgh, PA 15202
Phone: (412) 312-6000
Fax: (412)-312-6227

UGR006/1001

Record your equipment's model and serial number(s) and the date you received it in the spaces provided.

It is important to record the model and serial number(s) of your equipment and the date you received it in the User Guide. Our service department uses this information, along with the manual number, to provide help for the specific equipment you installed.

Keep this User Guide and all manuals, engineering prints and parts lists together for documentation of your equipment.

Date:
Document Number: UGR006/1001
Serial number(s):
Model number(s):
Power Specifications: Amps Volts Phase Cycle

DISCLAIMER: The Conair Group, Inc., shall not be liable for errors contained in this User Guide or for incidental, consequential damages in connection with the furnishing, performance or use of this information. Conair makes no warranty of any kind with regard to this information, including, but not limited to the implied warranties of merchantability and fitness for a particular purpose.

TABLE OF CONTENTS

INTRODUCTION	1-1
Purpose of the User Guide	1-2
How the User Guide is Organized	1-2
Your Responsibility as a User	1-2
ATTENTION: Read this so no one gets hurt	1-3
DESCRIPTION	2-1
What is the MXR Sprue Picker?	2-2
Typical Applications	2-3
Limitations	2-3
How the Sprue Picker Works	2-4
MXR Sprue Picker Features	2-5
Specifications	2-6
Optional Equipment	2-7
INSTALLATION	3-1
Unpacking the Boxes	3-2
Preparing for Installation	3-3
Preparing the Platen	3-4
Positioning the Sprue Picker	3-5
Connecting the Main Power Source	3-6
Setting Air Pressure	3-7
Releasing the Cylinder Lock	3-7
Adjusting the Pivot	3-8
Adjusting Swing Angle	3-8
Connecting the Hand Control	3-9
Turning on the Robot	3-9
Adjusting the Strip and Vertical Stroke	3-10
Changing the Wrist Flip	3-12
Adjusting the Speed	3-13
Adjusting the Sprue Verification Switch	3-14
Verifying the Electrical Interface	3-16
OPERATION	4-1
Hand Control Features	4-2
Before Starting	4-3
Starting the Sprue Picker	4-3
Stopping the Sprue Picker	4-4
Emergency Stopping	4-4
Viewing Information	4-4
Selecting Functions	4-5
Selecting Special Functions	4-6
Operating Manually	4-7
Starting Automatic Operation	4-8
Restarting Automatic Operation	4-8
Choosing the Motion Sequence	4-9

TABLE OF CONTENTS

CONT'D

OPERATION,CONT'D
Copying a Motion Sequence	4-9
Programming a New Motion Sequence	4-10
Programming Timer Settings	4-12
Monitoring Input/Output	4-14
Answering an Alarm	4-14

MAINTENANCE5-1
Maintenance Features	5-2
Warnings and Cautions	5-2
Preventative Maintenance Schedule	5-4
Checking Electrical Connections	5-6

TROUBLESHOOTING6-1
Before Beginning	6-2
A Few Words of Caution	6-2
Identifying the Cause of a Problem	6-2
Answering an Alarm	6-3
The Sprue Picker Does Not Cycle	6-8
The Mold is Not Working Properly	6-9
The Arm is Not Working Properly	6-10
Strip Motion is Not Working	6-11
There is No Swing Motion	6-12
The Gripper Does Not Work	6-13
There is No Vacuum	6-14

APPENDIXA-1
Customer Service	A-1
Guarantee/Warranty	A-2
Adding a Second Descent	B-1
Electrical Diagrams	C-1
Motion Sequences	D-1

PARTS/DIAGRAMSP/D-1
---------------------------------	---------------

INTRODUCTION

- *Purpose of the User Guide1-2*
- *How the User Guide
is organized1-2*
- *Your Responsibilities
as a User1-2*
- *ATTENTION: Read this so
no one gets hurt1-3*

PURPOSE OF THE USER GUIDE

This User Guide describes the Conair MXR Sprue Pickers and explains step-by-step how to install, operate, maintain and repair this equipment.

Before installing this product, please take a few moments to read the User Guide and review the diagrams and safety information in the instruction packet. You also should review manuals covering associated equipment in your system. This review won't take long, and it could save you valuable installation and operating time later.

HOW THE USER GUIDE IS ORGANIZED

Symbols have been used to help organize the User Guide and call your attention to important information regarding safe installation and operation.



Symbols within triangles warn of conditions that could be hazardous to users or could damage equipment. Read and take precautions before proceeding.



Numbers within shaded squares indicate tasks or steps to be performed by the user.



A diamond indicates the equipment's response to an action performed by the user.



An open box marks items in a checklist.



A shaded circle marks items in a list.

YOUR RESPONSIBILITY AS A USER

You must be familiar with all safety procedures concerning installation, operation and maintenance of this equipment. Responsible safety procedures include:

- Thorough review of this User Guide, paying particular attention to hazard warnings, appendices and related diagrams.
- Thorough review of the equipment itself, with careful attention to voltage sources, intended use and warning labels.
- Thorough review of instruction manuals for associated equipment.
- Step-by-step adherence to instructions outlined in this User Guide.

We design equipment with the user's safety in mind. You can avoid the potential hazards identified on this machine by following the procedures outlined below and elsewhere in the User Guide.

 **ATTENTION:**
READ THIS SO NO
ONE GETS HURT



WARNING: Improper installation, operation, or servicing may result in equipment damage or personal injury.

This equipment should only be installed, adjusted, and serviced by qualified technical personnel who are familiar with the construction, operation, and potential hazards of this type of machine.

All wiring, disconnects, and fuses should be installed by qualified electrical technicians in accordance with electrical codes in your region. Always maintain a safe ground. Do not operate the equipment at power levels other than what is specified on the machine serial plate.



WARNING: Voltage hazard.

This equipment is powered by alternating current, as specified on the machine serial tag and data plate.

A properly sized conductive ground wire from the incoming power supply must be connected to the chassis ground terminal inside the electrical enclosure. Improper grounding can result in severe personal injury and erratic machine operation.

Always disconnect and lock out the incoming main power source before opening the electrical enclosure or performing non-standard operating procedures such as routine maintenance. Only qualified personnel should perform troubleshooting procedures that require access to the electrical enclosure while power is on.



CAUTION: Equipment hazard.

Do not plug an MX Sprue Picker control into an interface wired for the MXR Sprue Picker control. Damage will occur! Call Conair Service if you are unsure or have any questions.

DESCRIPTION

- *What is the Sprue Picker?2-2*
- *Typical Applications2-3*
- *Limitations2-3*
- *How the Sprue Picker Works . . .2-4*
- *MXR Sprue Picker Features2-5*
- *Specifications2-6*
- *Optional Equipment2-7*

WHAT IS THE MXR SPRUE PICKER?

The MXR Sprue Picker is a pneumatic robot that removes the molded part or sprue runner system from the injection molding machine. Sprue pickers are mounted on a fixed platen on the injection machine. When the mold opens, the robot arm lowers into the mold area, grips the sprue or part and pivots to place the item in a designated area.



MXR 150

MXR 250

Conair MXR Sprue Pickers are ideal for applications requiring quick, consistent sprue/part removal from either a moveable or stationary platen. The robot interfaces directly with the mold machine to ensure predictable, constant cycle times. This allows accurate time quoting for production and maintenance schedules.

TYPICAL APPLICATIONS

Use the MXR Sprue Pickers to eliminate common problems:

- difficult programming
- contacting the factory for reprogramming
- inconsistent cycle times
- improper part/sprue separation
- unsafe sprue/part removal

Choose Conair MXR Sprue Pickers based on the size of the injection molding machine you are using.

LIMITATIONS

MXR Sprue Picker	For Injection Mold Machine Size, ton
MXR-60	20 to 60
MXR-150	60 to 150

* Contact Conair for suitability of application. Larger presses may be accommodated.

NOTE: Use this table only as a general guide. Application data sheet information determines the proper size of sprue picker for your application. Consult your Conair representative for assistance when choosing a Conair MXR Sprue Picker.

HOW THE SPRUE PICKER WORKS

The MXR Sprue Picker interfaces with the mold machine. The hand control provides the buttons for controlling and monitoring the sprue picker. From the hand control you can:

- monitor the input/output status
- set and adjust cycling times in both manual and automatic mode
- set and adjust vertical and horizontal strokes
- program motion sequencing
- operate the picker manually
- operate the picker automatically
- store programs

The sprue picker sends a signal to the mold machine to begin the cycle. The sprue picker receives the Mold Open signal from the mold machine to remove the sprue/part. The robot arm moves into the mold area, grips the part, and raises out of the mold. The arm pivots outside the press area to release the part/runner. The sprue picker sends a signal to the mold machine to begin the next cycle.

Each sprue picker is equipped with a part verification switch to stop the molding machine if a part is missed.

The MXR Sprue Picker models have these features:

MXR SPRUE PICKER FEATURES

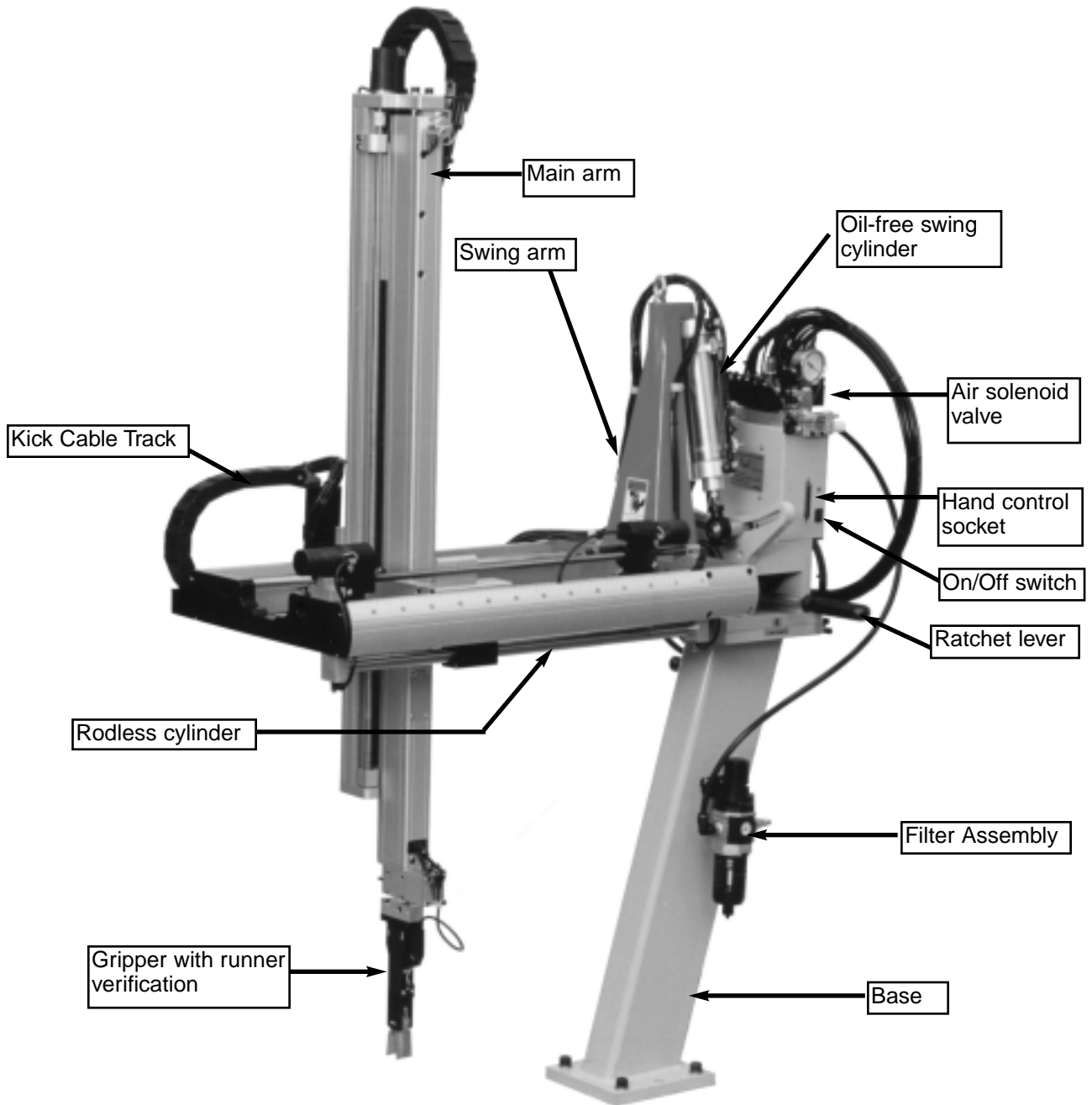

SPECIFICATIONS

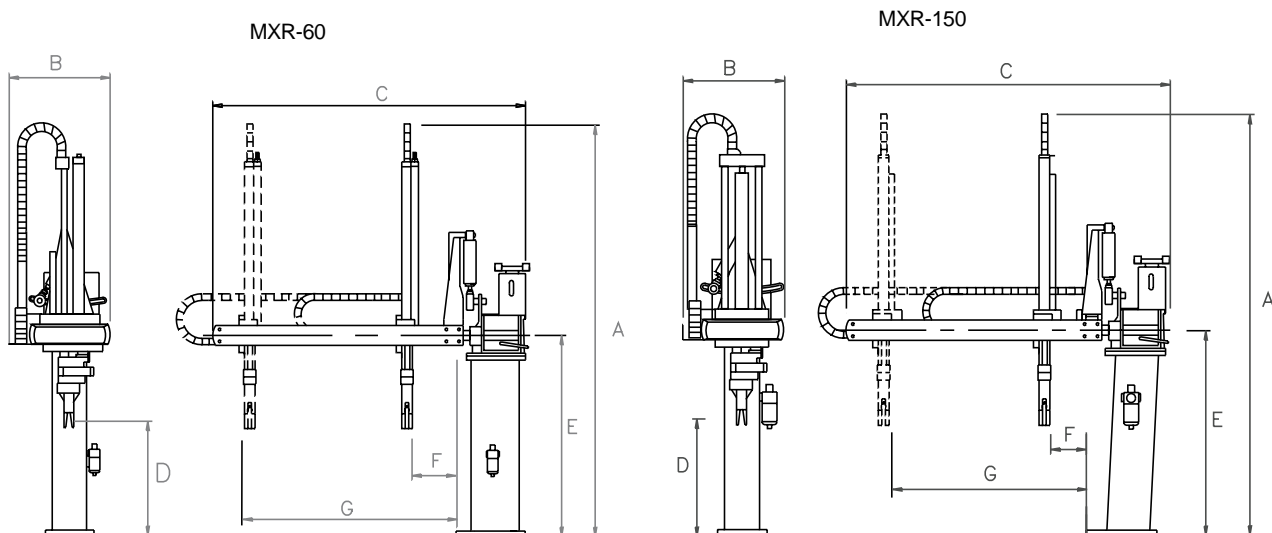

MODEL	MXR-60	MXR-150
Dimensions, in. {mm}		
A-Height	49.2 {1250}	53 {1350}
B-Width	11.4 {290}	11.4 {290}
C-Length	23.6 {600}	28.3 {720}
D-Grip Center		
Above Platen	9.4 {240}	9.4 {240}
- with wrist rotation	4.7 {120}	4.7 {120}
E-Swing Point Above Platen	23.8 {605}	3.89 {605}
Strip Stroke Adjustment, F to G	3.5-11 {90-280}	3.5-15.7 {90-400}
Strip Stroke	12..2 {310}	16.9 {429}
Performance characteristics		
Injection machine size, ton	20 - 60	60 - 150
Swing Angle, °	45 - 90	45 - 90
Wrist Rotation Angle, °	90	90
Min. Takeout Time, sec	0.6	0.7
Min. Cycle Time, sec	3	3.2
Weight, lb {kg}		
Installed	56 {25}	60 {27}
Shipping	81 {37}	85 {39}
Physical Characteristics		
Air Consumption, CFM {NI/cycle}	3 {85}	3 {85}
Approximate Max. Payload, lb {kg}		
- w/o wrist rotation	2.2 {1}	2.2 {1}
- with wrist rotation	1.1 {0.5}	1.1 {0.5}
Working Air Pressure, PSI {MPa} @ 3 CFM	80 {11.6}	80 {11.6}
Power Consumption, amps		
115V/1 phase/50-60 Hz	5	5
220V/1 phase/50-60 Hz	2.5	2.5
*Optional		

OPTIONAL EQUIPMENT

Options available on all models include:

- **Second ascent slowdown**
Controls arm retraction speed over gate (ascent slow-down).
- **Venturi vacuum kit**
Allows the use of vacuum end-of-arm tooling to remove light duty parts.
- **Sprue cutting systems**
- **End-of-arm tooling**
Used for light duty part removal.
- **Grip pressure regulator**
Reduces gripper pressure, preventing sprue/runner from being squeezed flat and causing a false Missed Runner alarm.

INSTALLATION

- *Unpacking the Boxes*3-2
- *Preparing for Installation*3-3
- *Preparing the Platen*3-4
- *Positioning the Sprue Picker* . . .3-5
- *Connecting the Main
Power Source*3-6
- *Setting Air Pressure*3-7
- *Releasing the Cylinder Lock* . . .3-7
- *Adjusting the Pivot*3-8
- *Adjusting Swing Angle*3-8
- *Connecting the Hand Control* . .3-9
- *Turning on the Robot*3-9
- *Adjusting the Strip and
Vertical Stroke*3-10
- *Changing the Wrist Flip*3-12
- *Adjusting the Speed*3-13
- *Adjusting the Sprue
Verification Switch*3-14
- *Verifying the
Electrical Interface*3-16

UNPACKING THE BOXES

The MXR Sprue Picker comes fully assembled in a single crate.



CAUTION: Lifting

To avoid personal injury or damage to the sprue picker, lift the sprue picker using a forklift or hoist with straps that have been positioned at the sprue picker's center of gravity.

- 1 Carefully uncrate the sprue picker and its components.**
- 2 Remove all packing material,** protective paper, tape, and plastic. Compare contents to the shipping papers to ensure that you have all the parts.
- 3 Carefully inspect all components** to make sure no damage occurred during shipping. If any damage is found, notify the shipping agent immediately. Check all wire terminal connections, bolts, and any other electrical connections, which may have come loose during shipping.
- 4 Record serial numbers and specifications** in the blanks provided on the back of the User Guide's title page. This information will be helpful if you ever need service or parts.
- 5 You are now ready to begin installation.** Complete the preparation steps on page 3-3.

PREPARING FOR INSTALLATION



CAUTION: Moving the Sprue Picker

When you receive the sprue picker, the swing is bolted to prevent movement. On the MX-R60 to MX-R150 models, a bolt goes through the swing angle adjustment bracket into the base. This prevents the arm from swinging.

On the MX-R250 to MX-R450 models, there is an L-bracket between the swing casting and the base. Leave the swing inhibitor on until the sprue picker is mounted on the press. Remove after mounting.



WARNING: Improper installation, operation, or servicing may result in equipment damage or personal injury.

This equipment should only be installed, adjusted, and serviced by qualified technical personnel who are familiar with the construction, operation, and potential hazards of this type of machine.

All wiring, disconnects, and fuses should be installed by qualified electrical technicians in accordance with electrical codes in your region. Always maintain a safe ground. Do not operate the equipment at power levels other than what is specified on the machine serial tag and data plate.

Plan the location. Make sure the area where the sprue picker is installed has:

- **A grounded power source.** Check the sprue picker's serial tag for the correct amps, voltage, phase, and cycle. All wiring should be completed by qualified personnel and comply with your region's electrical codes.
- **Clearance for safe operation and maintenance.** Make sure there is enough clearance around the sprue picker for movement, maintenance and servicing. Be sure the sprue picker has proper clearance to avoid structures, utilities, overhead cranes, and loading pipes, as well as other machines and equipment. Be sure that the maximum envelope is clearly marked and protected from entry by personnel during operation. The maximum envelope is the volume of space encompassing the maximum designed movement of ALL robot parts, including the end of arm tooling, work piece and attachments.

PREPARING THE PLATEN

You need to drill holes in the stationary (fixed) platen to accept the sprue picker.

Mounting pattern for MX-R60 and MX-R150*

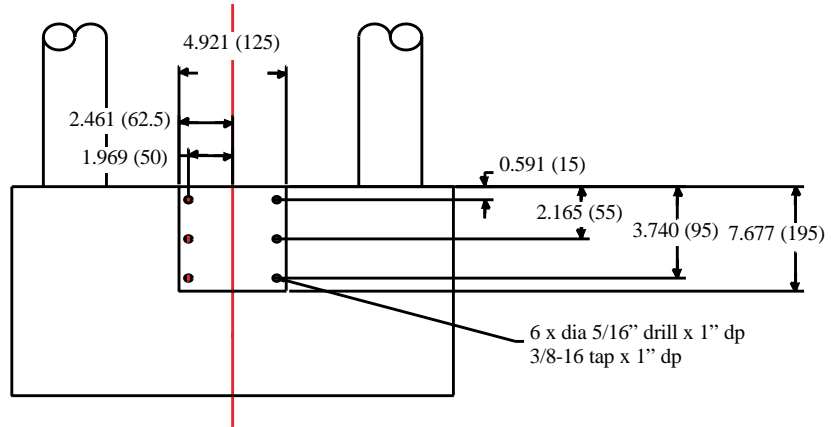

Mounting pattern for MX-R250 to MX-R550*

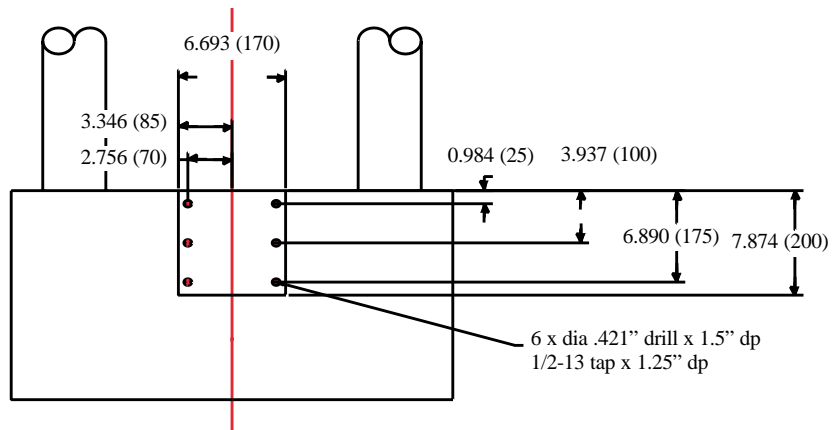

*Dimensions shown are inches (mm).



CAUTION: Lifting

To avoid personal injury or damage to the sprue picker, lift the sprue picker using a hoist. Place the straps around the swing shaft between the strip frame and the base.

POSITIONING THE SPRUE PICKER

1 Mount an eyebolt in the eyehole.

2 Move the sprue picker into position.

Using a strap, hoist the sprue picker into position on the platen.

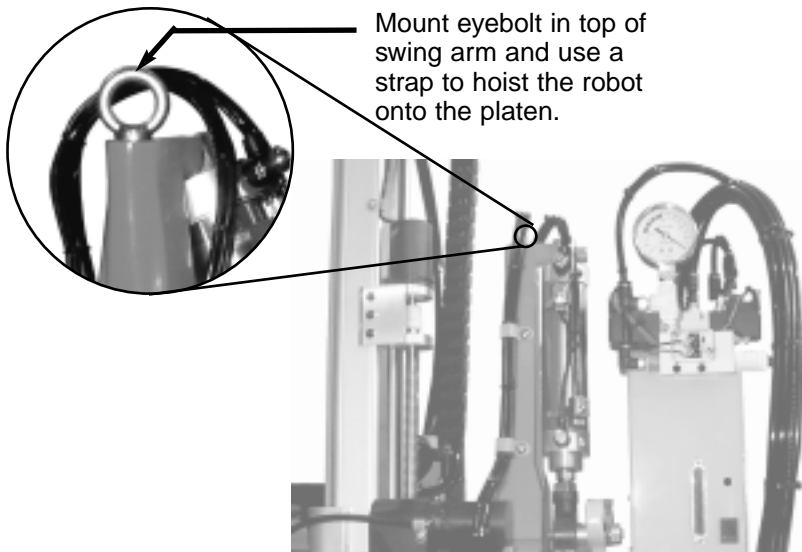

3 Secure the sprue picker to the platen

with the supplied screws, lock washers, and flat washers.

4 Remove the swing inhibitor.

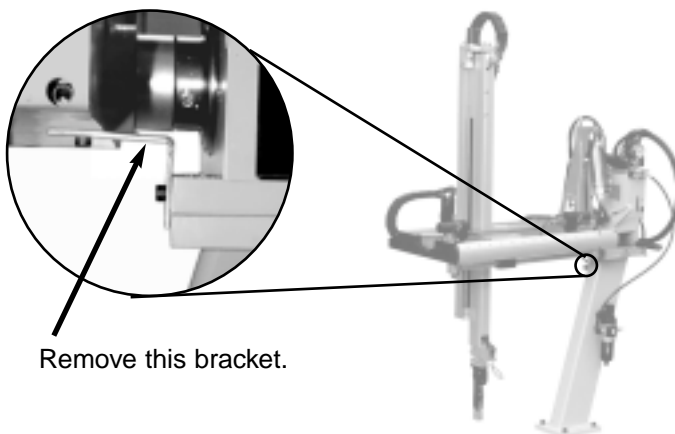

CONNECTING THE MAIN POWER SOURCE



WARNING: Electrical hazard

Before performing any work on this product, disconnect and lock out electrical power sources to prevent injury from unexpected energization or start-up.



WARNING: Improper installation, operation, or servicing may result in equipment damage or personal injury.

This equipment should only be installed, adjusted, and serviced by qualified technical personnel who are familiar with the construction, operation, and potential hazards of this type of machine.

All wiring, disconnects, and fuses should be installed by qualified electrical technicians in accordance with electrical codes in your region. Always maintain a safe ground. Do not operate the equipment at power levels other than what is specified on the machine serial tag and data plate.



WARNING: Crushing Injury

This device has high speed moving parts that can cause crushing injuries. Keep body parts and clothing away from moving parts. Always disconnect the sprue picker from compressed air sources before servicing.

Do not operate machine unless you are trained and have read and understood this user guide.

IMPORTANT: Always refer to the wiring diagrams that came with your sprue picker before making electrical connections. The diagrams show the minimum size main power cable required for your sprue picker, and the most accurate electrical component information.

- 1 Disconnect and lock out main power supply** to which the sprue picker will be connected.
- 2 Inspect the wiring of the sprue picker and the IMM SPI interface connections.**
- 3 Connect the sprue picker SPI plug** to the IMM SPI receptacle.
- 4 Apply main power to the IMM interface.**

The MXR Sprue Picker is pneumatically driven. A filter regulator and an air valve adjust the air pressure. Connect the factory air line to the filter regulator. Adjust the air pressure:

SETTING AIR PRESSURE

- 1 Pull up and turn the knob clockwise to increase the air pressure.**
- 2 Pull up and turn the knob counter-clockwise to decrease the air pressure.**
- 3 Set the air pressure to 0.4-0.6 MPa (58-87 PSI) on the pressure gauge.**
- 4 Push the knob down to lock it into position.**

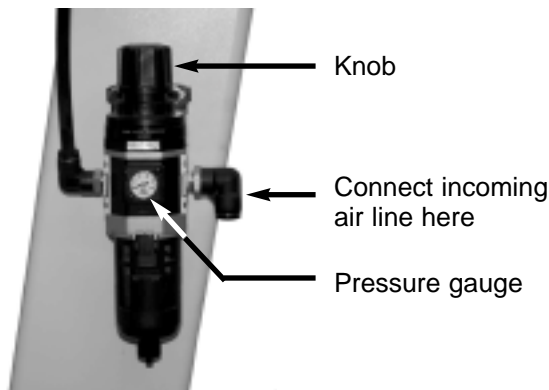

Filter regulator



CAUTION: Equipment damage

Hold the main arm securely when releasing the cylinder lock to prevent the arm from dropping quickly and causing equipment damage.

RELEASING THE CYLINDER LOCK

- 1 Drop the air pressure to 0MPa at the filter regulator using the safety bleed of the valve.**
- 2 Hold the main arm securely.**
- 3 Pull the ring out of the lock cylinder.**

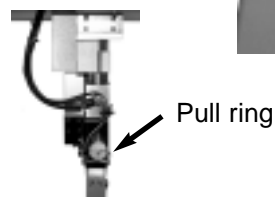
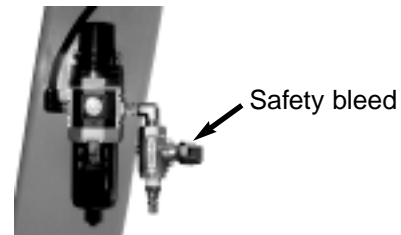

ADJUSTING THE PIVOT

The MXR Sprue Picker strip frame can pivot to move the picker out of the way when the mold is changed. You need to adjust the pivot stop so that the axis of the strip frame is parallel with the base of the press. The stop allows the picker to pivot back into position after the mold change.

Adjust the pivot stop, if required, to compensate for any misalignment of the bolt pattern after installation.

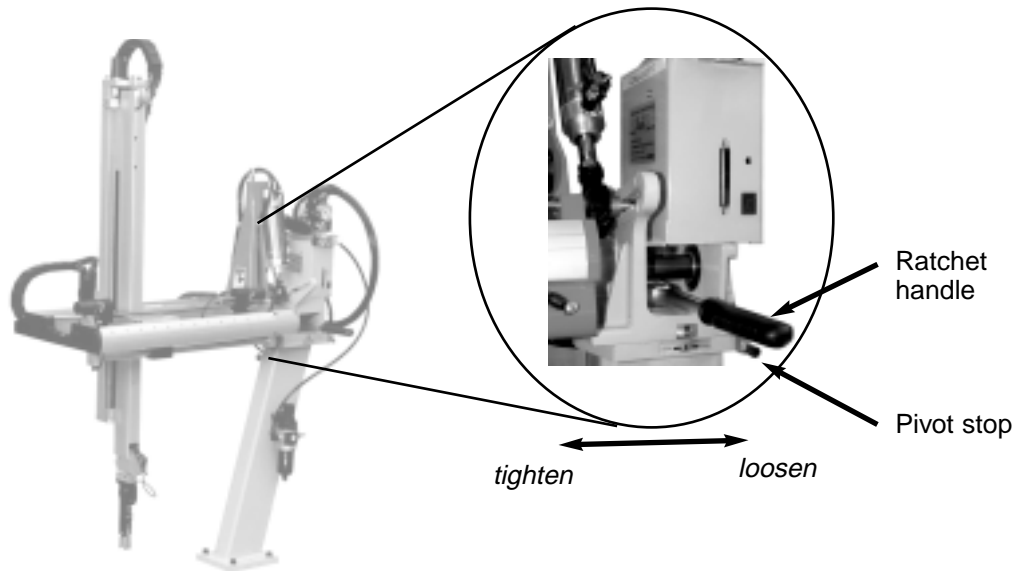

ADJUSTING SWING ANGLE

You can easily change the sprue picker/runners to release parts to either side of the press by changing the swing cylinder position.



WARNING: Air pressure hazard

When adjusting the swing, turn OFF compressed air to the sprue picker. Disconnect the air supply before making any adjustments!

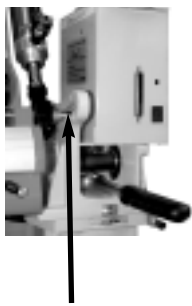

- 1 Exhaust the air supply completely.**
- 2 Loosen the Swing Adjustment nut.**
- 3 Set the direction and the angle by moving the cylinder mounting in the bracket slot.**
- 4 Tighten the nut securely after the adjustment.**

Plug the hand control cord into the socket on the front of the sprue picker:

CONNECTING THE HAND CONTROL

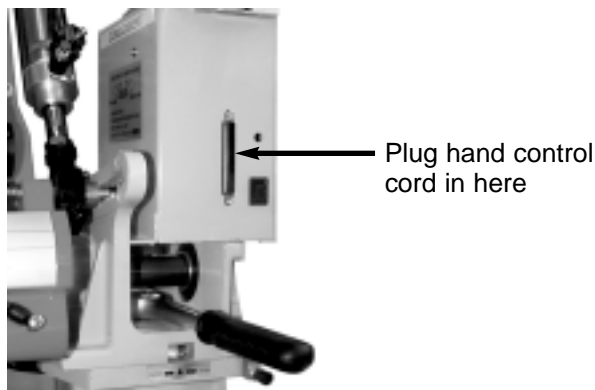

Only after connecting and setting the air pressure and then connecting the hand control should the sprue picker be turned on. Flip the red On/Off switch next to the hand control socket on the front of the sprue picker:

TURNING ON THE ROBOT

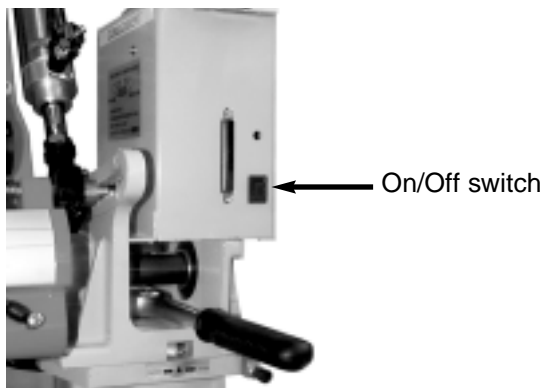

The On/Off switch lights and the hand control is now on. The hand control boots up when the sprue picker is on. After boot up, the LCD on the control displays the current software version number, the Conair 800 phone number, and the current module in use:

```
VER: BH V02. 1460  
CONAIR  
800-458-1960  
USE MODULE: 30
```

ADJUSTING STRIP AND VERTICAL STROKES



CAUTION: Equipment damage

When adjusting the stroke make sure the gripper always clears the mold when it descends. Failure to heed can cause damage to the mold and the robot.

Use the hand control to move each of the three motors to adjust the strip and vertical strokes.

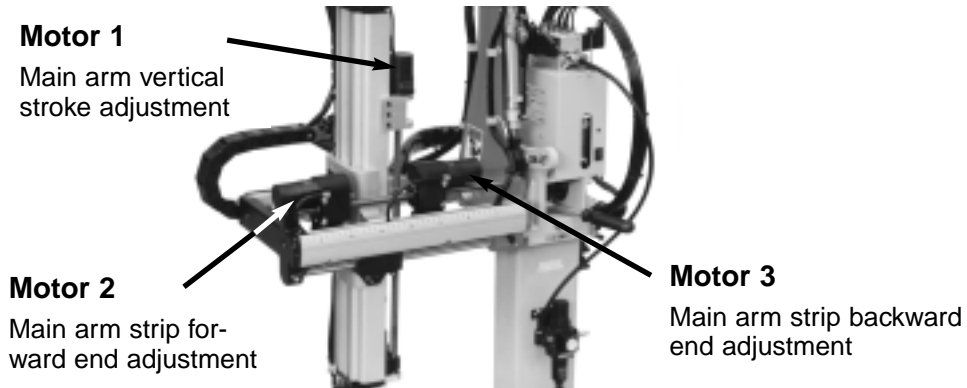

To adjust the stroke length:

1 Press the Stop button.



2 Press the Manual button.



3 Press the Remote button.

The LCD displays three choices, letting you choose to set the down stroke, forward stroke and backward stroke.



► 1) SET DOWN
2) SET FWD
3) SET BACK
NOW SELECT IN 01

The display also shows which choice you currently have. In this case item 1 is chosen.

4 Use the numerical keypad and press 1 to set the vertical downward movement.



5 Press the up and down arrows to move the stop positions. Continue to press the arrow until the stop is located where you want it. The motor stops 10 seconds after the button is pressed.



6 Press 2 to set the forward strip stroke.



7 Press the left and right arrows to move the stop positions. Press and hold the arrow until the stop is located where you want it. The motor stops 10 seconds after the button is released.



8 Press 3 to set the backward strip stroke.



9 Press the left and right arrows to move the stop positions. Press and hold the arrow until the stop is located where you want it. The motor stops 10 seconds after the button is released.



10 Press the Stop button after all settings are complete.



You may make stroke adjustments when the sprue picker is in manual mode. To do this:

1 Press the Stop button.



2 Press the Manual button to enter Manual mode.



3 Use the numerical keypad and press 1 to set the vertical downward movement.



4 Press the Manual button.



5 Press the Remote button to enter the Remote Adjustment mode. Follow steps 5 through 10 above to set and adjust each stroke and position.



CHANGING THE WRIST FLIP



WARNING: Air pressure hazard

When making adjustments to the wrist flip, turn OFF compressed air to the sprue picker. Disconnect the air supply before making any adjustments!

1 **Disconnect and exhaust the air supply** completely.

2 **Swap the hoses for the wrist flip actuator.**

This is done at the swing valve. The wrist flip is actuated with the swing motion:

Swing out = wrist flip out

Swing in = wrist flip home.

Swap the two outside hoses. Make sure the air is OFF and drained before making the change.

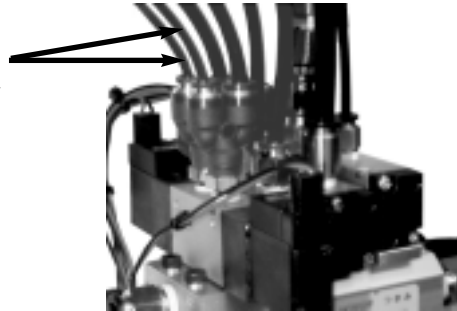

3 **Turn the air on and return the arm to the vertical position (swing is in).** The gripper is rotated 90° the wrong way.

4 **Loosen the screw on the clamp block.**

Reposition the gripper on the wrist flip actuator to bring it into the proper orientation.

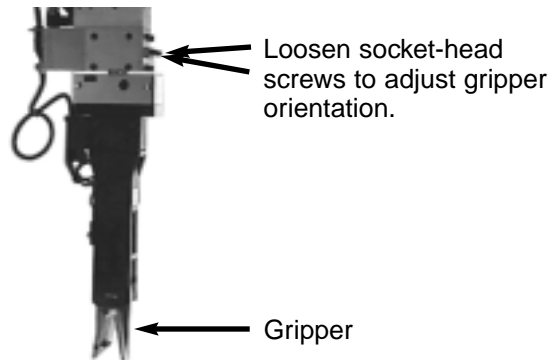

5 **Turn the gripper by hand back back to its original position.**

6 **Tighten the clamp screws to lock the gripper** in position on the wrist flip shaft.

The flow controls are used to adjust the picker speeds. You can adjust:

- **swing-in movement**
- **swing-out movement**
- **main cylinder ascent**
- **wrist-flip in**
- **wrist-flip out**

ADJUSTING THE SPEED



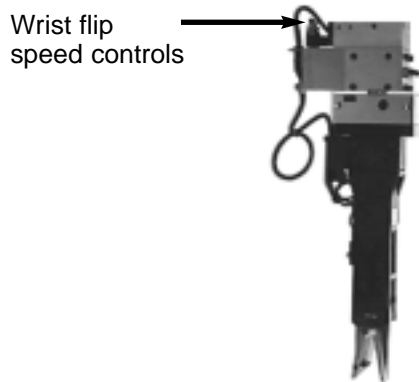
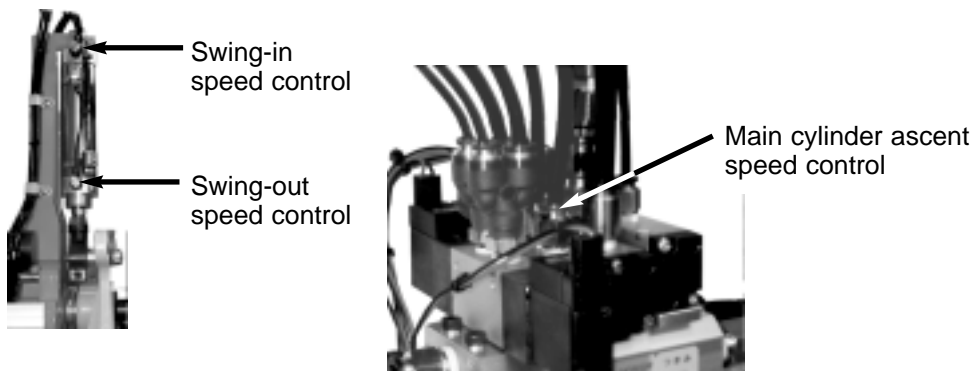

To adjust the speed, loosen lock nut and turn the flow control knobs clockwise to slow the picker. Turning the controls counter-clockwise causes the picker to speed up. Tighten the lock nut after making adjustments.



ADJUSTING THE SPRUE VERIFICATION SWITCH

The sprue verification switch can be set two different ways, depending on how you want to use the gripper. The sensor can be adjusted to be on when a sprue is in the grip and off when the gripper is closed or open without a sprue. The switch can also be set to be on when the gripper is closed and off when open or a part is in the gripper.

Adjusting the switch to ON with a sprue:

- 1** Press the Stop button. 
- 2** Press the Manual button. 
- 3** Press the 3 button (Grip On/Off button) so that the gripper jaws are open. 
- 4** Place a sprue into the open gripper jaws.
- 5** Press the 3 button (Grip On/Off button) so that the gripper jaws close onto the sprue. 
- 6** Loosen and slide the switch on the gripper.
- 7** Adjust the LS-4 proximity sensor to achieve the following:

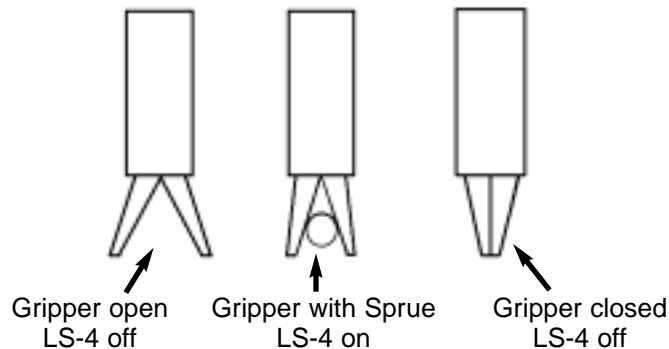



- 7** When adjusted, tighten the switch securely.

NOTE: Check the verification regularly to ensure the picker is correctly verifying the part/sprue removal. The adjustment may need reset if the sprue diameter changes (due to mold changes). If the gripper crushes the sprue completely, an optional grip regulator can be added to decrease the pressure used to grip the sprue.

When working with soft materials or parts that vary in diameter, set the LS-4 sensor to be on then the gripper is closed.

Adjusting the switch to ON with gripper closed:

- 1** Press the Stop button. 
- 2** Press the Manual button. 
- 3** Press the 3 button (Grip On/Off button) so that the gripper jaws are closed. 
- 4** Loosen and slide the switch on the gripper.
- 5** Adjust the LS-4 proximity sensor to achieve the following:

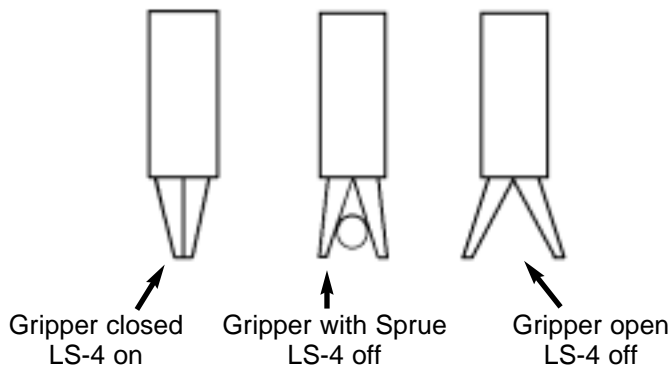

- 6** When adjusted, tighten the switch securely.

VERIFYING THE ELECTRICAL INTERFACE

The electrical interface between the sprue picker and the injection molding machine (IMM) is the most important part of the installation. The interface must function correctly to maintain the safety of the sprue picker and the mold.



CAUTION: Equipment hazard.

Do not plug an MX Sprue Picker control into an interface wired for the MXR Sprue Picker control. Damage will occur! Call Conair Service if you are unsure or have any questions.

Electrical Diagrams are in the Appendix.

Verifying signals from sprue picker to IMM

Check the following interface signals:

- **Permit Clamp Close**

Signal indicates the sprue picker is in a predetermined safe position for the IMM clamp to close. If the sprue picker is not clear of the mold area, clamp closing must be inhibited. Also, if the sprue picker misses a part, the clamp must be inhibited from closing.

- **Permit Clamp Motion**

When the sprue picker arm is in a safe area this signal allows IMM clamp motion.

- **Mold Ejection (Forward)**

The ejection of the part can be controlled by the sprue picker. This ensures the proper placement of the sprue picker gripper before the sprue/runner is ejected.

- **Robot Non-operational**

The switch contact is open when the IMM is operated with the robot. The switch is closed when the IMM is operated without the robot; the Permit Clamp Close, Permit Clamp Motion, and Emergency Stop are still monitored. All other signals can be in an undetermined state.

- **Emergency Stop**

When the robot emergency stop is activated the circuit opens and activates the IMM emergency stop circuit.

Verifying signals from IMM to sprue picker

Verify the following signals as functional and correct:

- **Mold Fully Open**

This signal indicates that the mold is in a predetermined fully open position. This is a very important signal. If the sprue picker enters, or attempts to enter, the mold at the wrong time damage to the arm and/or mold can occur.

- **Mold Fully Closed**

This signal is sent to the sprue picker when the mold is fully closed or locked up.

- **Safety Gates Closed**

This signal tells the sprue picker that the safety gates that prevent access to robot motions are closed.

- **Fully Automatic**

When signal indicates the the IMM is in full automatic operation mode.

- **Reject Part**

The IMM signals the sprue picker there is a rejected part. The sprue picker grabs the part, strips it and immediately releases it without moving it outside.

- **Emergency Stop**

When the IMM emergency stop is activated the circuit opens and activates the emergency stop circuit of the sprue picker.

OPERATION

- **Hand Control Features4-2**
- **Before Starting4-3**
- **Starting the Sprue Picker4-3**
- **Stopping the Sprue Picker4-4**
- **Emergency Stopping4-4**
- **Viewing Information4-4**
- **Selecting Functions4-5**
- **Selecting Special Functions . . .4-6**
- **Operating Manually4-7**
- **Starting Automatic
 Operation4-8**
- **Restarting Automatic
 Operation4-8**
- **Choosing the Motion
 Sequence4-9**
- **Copying a Motion Sequence . . .4-9**
- **Programming a new
 Motion Sequence4-10**
- **Programming Timer
 Settings4-12**
- **Monitoring Input/Output4-14**
- **Answering an Alarm4-14**

HAND CONTROL FEATURES

The sprue picker control has several features that allow you to input setup information, monitor input/output, change modes, and view errors.

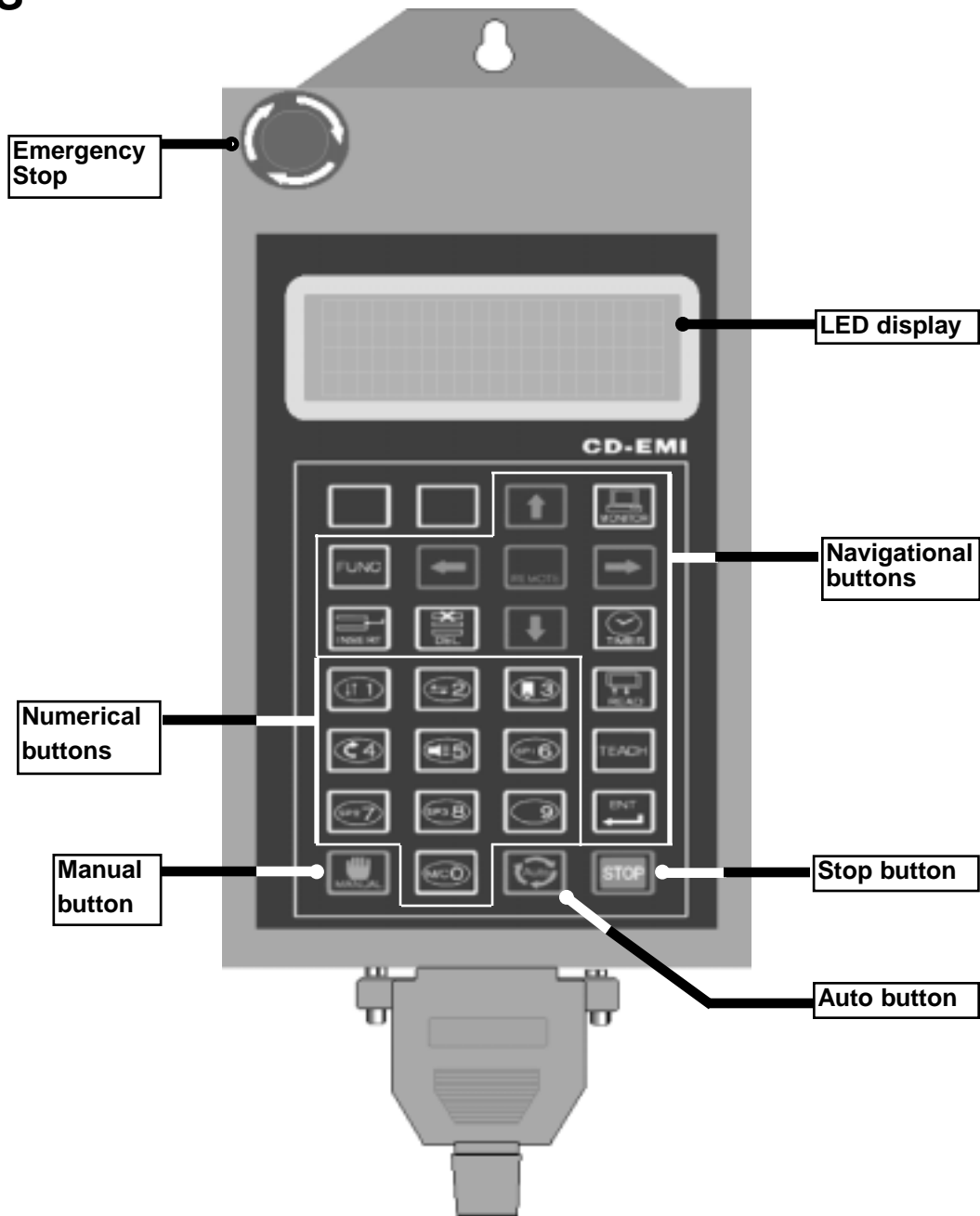

Before you start daily operation of the sprue picker, perform preventative maintenance. This includes daily, weekly, monthly and semi-annual maintenance. Maintenance procedures are described in the Maintenance section of this Users Guide, beginning on page 5-1.

BEFORE STARTING



WARNING: Be sure that power to the sprue picker is disconnected and locked out when doing any maintenance on it. Follow all safety rules when performing any maintenance on this equipment.

The power must be on for any picker or press operations to occur.

STARTING THE SPRUE PICKER

On Mode

In the On position the picker runs with the press. The operator can cycle the picker in either manual mode or automatic mode.

Off Mode

When the picker is in the Off position, the press operates without the sprue picker. The interlock signals for the mold are released. The interlocks are still monitored, however, to ensure the picker is in a safe position for opening and closing the mold.

NOTE: When in the Off mode, the sprue picker does not remove parts/sprues from the press. The operator must do it.

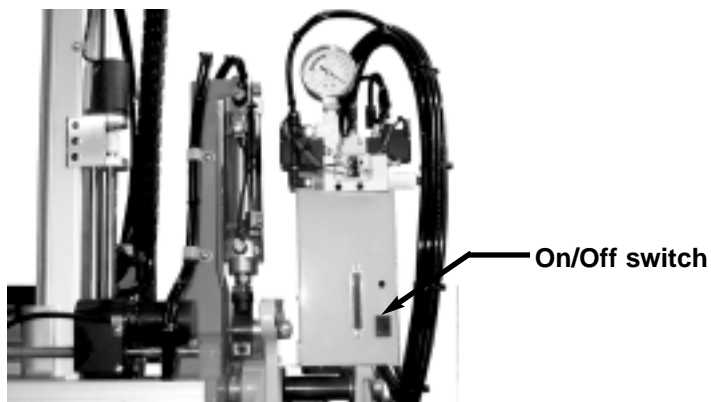

STOPPING THE SPRUE PICKER

To stop the sprue picker with the hand control, press the Stop button.



EMERGENCY STOPPING

If, at any time, you need to immediately stop the sprue picker, press the Emergency Stop button.

The sprue picker retracts the arm up and stops.

Check the mold and remove any parts that may still be in the mold.

After the emergency is handled, reset the control by turning the E-stop button in the direction of the arrows (clockwise).

Press the Manual button to move the sprue picker.

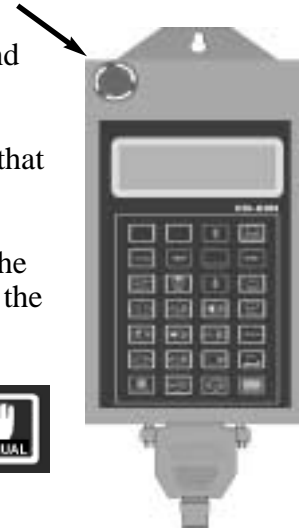

VIEWING INFORMATION

The LED on the control displays the data you input, the status of the sprue picker, and any error messages.

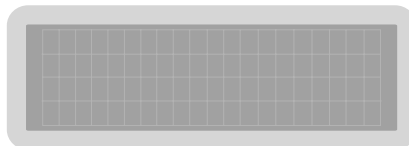

During normal operation the display provides:

- functions
- modes (manual. auto)
- motion sequencing (mold memory)
- teach modes
- timer settings

During an alarm or error, the display lists the alarm or error codes.

Before selecting and functions for the sprue picker decide which movements you wish the sprue picker to make.

SELECTING FUNCTIONS

To select a function:

1 Press the Function button.

The display shows that Function is selected, the item number, the status of the choice (on/off, in/out, etc) and directions. For example:

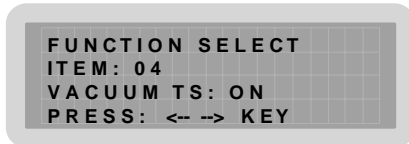

2 Press the arrow buttons to toggle between choices.



3 Press the Enter button to go to the next motion or when you have completed your selections.



The Functions selections include:

Item No.	Function	Description	Choices
01	Ejector motion	Select ejector link motion	ON - link with ejector OFF - not linked with ejector
02	Part Verification	Select the method for part (grip) verification on the main arm	NORMAL - switch is on when part is gripped INVERT - switch is on when grip is closed OFF - verification is not being used
04	Vacuum verification	Select to use or not use vacuum	ON - use vacuum verification switch OFF - do not use vacuum verification
05	Home position	Choose the home position	IN - home position is above the mold (standard position) OUT - home position is in the swing out position

OPERATING MANUALLY

In manual mode you can operate the sprue picker manually using the control buttons. The sprue picker operates in manual mode when the picker is in Stop mode, when the Mold Fully Open signal is on, and the safety gate is closed. To operate the sprue picker manually:

- 1 Make sure the sprue picker is stopped** and the mold is fully opened. Press the Stop button and verify the control displays Stop Mode.



- 2 Press the Manual button.** The LCD displays:

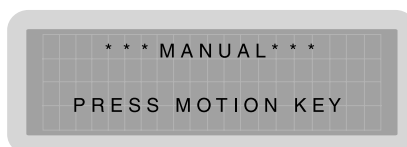

The sprue picker is now in manual mode and can be operated using the motion control buttons on the hand control. Motion control buttons include:

Button	Function	Description	Choices
	Arm motion	Press to move main arm down (arm descent motion). Press again to move main arm up.	↑ - moves main arm up ↓ - moves main arm down
	Strip motion	Press to move the arm forward; press again to move the arm backward.	← - moves the main arm forward → - moves the main arm backward
	Grip motion	Press to manually grip a part/sprue. Press again to release the part.	ON - grip is on OFF - grip is off
	Swing motion	Press once to swing arm out; press again to swing arm inward.	OUT - swing arm out IN - swing arm in
	Vacuum	Press to turn vacuum on; press again to turn vacuum off.	ON - vacuum is on OFF - vacuum is off
	Spare 1*	Use for optional motion.	ON - optional motion is on OFF - optional motion is off

*SP2 and SP3 buttons not available on this model

- 3 Press the Stop button to exit** manual mode.



Before placing the sprue picker into automatic operation, the Auto signal from the press must be present for the sprue picker to run. To start automatic operation:

1 Press the Stop button.

The sprue picker stops. If the arm is not in the Home position, press the Manual button and move the arm to the Home position, then press the Stop button.



2 Press the Auto button.

The control displays the auto mode information and the sprue picker begins automatic cycling. Auto cycling information displays on the LCD.



CAUTION

Press the Auto button only when the sprue picker is stopped and in the home position. If the button is pressed at any other time in the cycle of the sprue picker:

- The sprue picker stops
- The alarm sounds
- The error code displays on the hand control

Press the Stop button to silence the alarm.

NOTE: The sprue picker will start automatic operation immediately only if the Mold Full Open signal is ON.

STARTING AUTOMATIC OPERATION

To restart the automatic operation cycle when the sprue picker stops due to a part/sprue pickup failure:

1 Press the Stop button.



2 Open the safety door and verify that there is no part/sprue in the mold. If there is, manually remove it.



CAUTION: Clearing mold area.

It is the responsibility of the operator to verify that the mold area is clear after a missed parts condition. Follow all warnings and precautions for the mold machine before removing parts. Do not enter maximum envelope area while machine is operating.

3 Press the Auto button.

The sprue picker starts automatic operation immediately when the Mold Fully Open signal is ON.



RESTARTING AUTOMATIC OPERATION

MONITORING INPUT/OUTPUT

You can monitor the status of all inputs and outputs between the sprue picker and the injection molding machine. The input/output display can be viewed by pressing the Monitor button.



The LCD displays input information (LS) and output information (SOL):

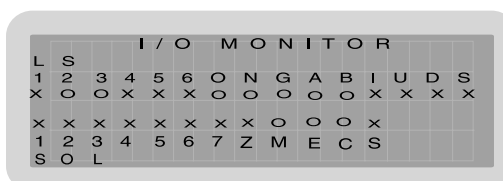

where X shows which switches/valves are OFF and O shows which ones are ON.

Input	Description	Output	Description
LS1	Swing outward end proximity switch	SOL1	Swing outward solenoid valve
LS2	Swing inward end proximity switch	SOL2	Swing inward solenoid valve
LS3	Main arm retract end proximity switch (arm up)	SOL3	Main arm extend/retract solenoid valve
LS4	Part (grip) verification switch	SOL4	Strip forward-backward solenoid valve
LS6	Vacuum differential switch	SOL5	Main arm grip solenoid valve
LSO	Mold fully open signal	SOL6	Vacuum solenoid valve
LSN	<i>Not available</i>	SOL7	<i>Not available</i>
LSG	Safety gate signal	SOLZ	Alarm output
LSA	Press in auto signal	SOLM	Mold area free; permit clamp motion output
LSB	Rejected part signal	SOLE	Permit ejector forward output
LSI	Mold fully closed signal	SOLC	Mold close start output (cycle start output)
LSU	Sprue picker ON/OFF signal	SOLS	Emergency stop from sprue picker output
LSD	Main arm descent end proximity switch (optional)		
LSS	Emergency Stop signal		

There are twelve standard motion sequences pre-programmed into the hand control memory - modules 00 to 11. The hand control also has the capability of adding up to 80 modules that you set yourself - modules 20 to 99 (modules 12 to 19 are reserved for units with sub arm function. This model does not contain that function). To choose a motion sequence:

CHOOSING THE MOTION SEQUENCE

1 Press the Read button.

The LCD displays the current module selected.
For example:

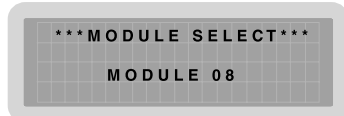

2 Use the numerical keypad to select a two-digit module number. This can be either a preprogrammed module or one that you have previously programmed.

Standard motion sequences can be found in the Appendix.

3 Press the Enter button to select the module.



To copy a currently programmed module:

1 Press the Read button TWICE.

The LCD displays:

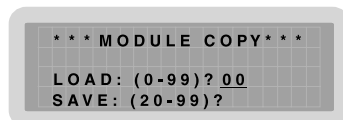

2 Use the numerical keypad to select the module number you want copied (loaded).

3 Press the Enter button.

The hand control has now selected your chosen module. The LCD displays:

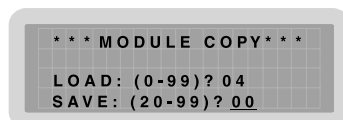

The LCD show the module number you just loaded. The cursor moves to the SAVE line

4 Enter the new module number.

5 Press the Enter button.



COPYING A MOTION SEQUENCE

PROGRAMMING A NEW MOTION SEQUENCE

Add a new motion sequence by displaying a current motion sequence and modifying it to create a new program. Up to 80 new programs can be stored in Modules 20 - 99. To program a new motion sequence:

1 Press the Teach button.

The LCD displays:

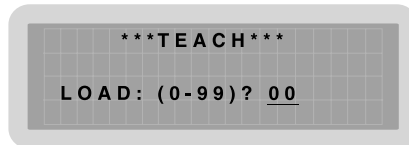

2 Enter the module number you want to modify.

For example, press 4 for module 4.

3 Press the Enter button.

The LCD displays showing the module you just loaded. The Save number flashes.

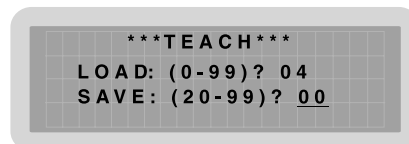

If you try to enter module numbers 1-19 an error message displays 'CAN'T SAVE 0-19'.

4 Enter the module number of the new motion

sequence you want to save. The motion sequence and timer value displays on the screen. The first two digits are the module number and the second two digits are the order number.

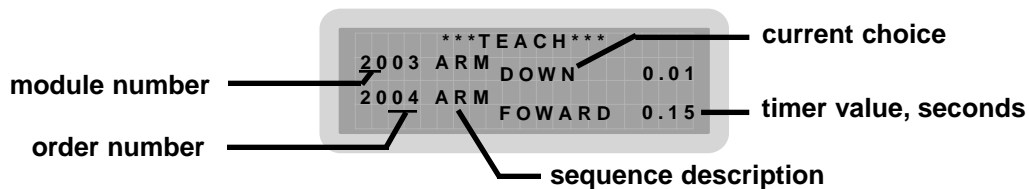

5 Press the Down and Up arrows

to scroll through the motions. The cursor moves down or up through the list and the digits flash.



CAUTION:

The sprue picker performs the motion as the arrow buttons are pressed. Take all safety precautions to prevent bodily injury or damage to equipment. Movement is necessary to confirm that the motion sequence is correct.

6 Stop scrolling when you want to insert, delete
or change a motion in the sequence.

7 Press the Insert button to insert a
new motion.



8 Press the button corresponding to the motion
you want to add:

Button	Function	Description	Choices
	Arm motion	Press to move main arm down (arm descent motion). Press again to move main arm up.	↑ - moves main arm up ↓ - moves main arm down
	Strip motion	Press to move the arm forward; press again to move the arm backward.	← - moves the main arm forward → - moves the main arm backward
	Grip motion	Press to manually grip a part/sprue. Press again to release the part.	ON - grip is on OFF - grip is off
	Swing motion	Press once to swing arm out; press again to swing arm inward.	OUT - swing arm out IN - swing arm in
	Vacuum	Press to turn vacuum on; press again to turn vacuum off.	ON - vacuum is on OFF - vacuum is off
	Spare 1*	Use for optional motion.	ON - optional motion is on OFF - optional motion is off

**SP2 and SP3 buttons not available on this model*

Press the motion button twice to toggle between choices.

9 Press the Enter button to save the motion.
Continue to scroll to through the list of motions and insert any other changes.



10 Use the Down and Up arrows to scroll
to any motion you want to delete.



11 Press the Delete button to
delete a motion.



12 Press the Enter button to save the change.



13 Use the down and up arrows to verify
that each step in the new program is correct.



When all programming is completed press the Stop button.



PROGRAMMING TIMER SETTINGS

Timer settings can be viewed and changed using the hand control under two conditions:

- when the sprue picker is in Timer mode
- during Auto mode (while picker is running). This is the most common one and the one you will use most often.



CAUTION:

The sprue picker performs the motion as the arrow buttons are pressed. Take all safety precautions to prevent bodily injury or damage to equipment. Movement is necessary to confirm that the motion sequence is correct.

The default timer setting is 0.5 seconds.

Programming Timer settings from Timer mode

NOTE: Timer settings can be changed in Timer mode only after the motion sequences are programmed.

1 Press the Timer button.

The LCD displays:



```
***TIMING MODIFY***
2000 PRO- DUCE 0000
2001 START
      DELAY 0.00
```

2 Press the Down and Up arrows

to scroll through the motions. The cursor moves down or up through the list and the digits flash. Stop when the cursor locates the time you want to change. Times are displayed in seconds to the second decimal place.



3 Enter the new timer setting using the numeric keypad. For instance, to change from 0.10 seconds to 3.00 seconds press 3, 0, 0.

4 Press the Enter button to save the change.



After all changes are made, press the Stop button to exit Timer mode.



Programming Timer settings during Auto mode

Timer settings can be changed when the sprue picker is in Auto mode and the robot is moving.



1 Press the Timer button.

The LCD displays:

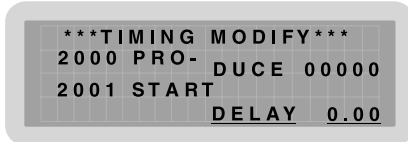

2 Press the Down and Up arrows

to scroll through the motions. The cursor moves down or up through the list and the digits flash. Stop when the cursor locates the time you want to change. Times are displayed in seconds to the second decimal place.



3 Enter the new timer setting using the numeric keypad.

For instance, to change from 0.10 seconds to 3.00 seconds press 3, 0, 0.

4 Press the Enter button to save the change.



After all changes are made, press the Auto button to exit Timer mode.



ANSWERING AN ALARM

When an error occurs during operation, the sprue picker stops, an alarm sounds and the error information displays on the hand control. Press the Stop button to silence the alarm. Go to the Troubleshooting section of this user guide to troubleshoot the alarm

MAINTENANCE

- *Maintenance Features*5-2
- *Warnings and Cautions*5-2
- *Preventative Maintenance*
 - Schedule*5-4
- *Checking Electrical*
 - Connections*5-6

MAINTENANCE FEATURES

The MXR Sprue Picker models need regular, scheduled maintenance for peak performance. Among the features that require maintenance are:

- Mechanical parts
- Electrical parts

WARNINGS AND CAUTIONS

To maintain the best performance of the sprue picker, it must be inspected regularly. Maintenance includes a daily, weekly, quarterly, and semi-annual (every 6 months) schedule.

Use this maintenance schedule as a guide. You may need to shorten the time of the maintenance schedule, depending on how often you use the sprue picker.

Follow all precautions and warnings when working on the equipment.



WARNING: Improper installation, operation, or servicing may result in equipment damage or personal injury.

This equipment should only be installed, adjusted, and serviced by qualified technical personnel who are familiar with the construction, operation, and potential hazards of this type of machine.

Be sure the sprue picker has proper clearance to avoid structures, utilities, overhead cranes, material hoppers and loading pipes, as well as other machines and equipment.

Be sure that the maximum envelope is clearly marked and protected from entry by personnel during operation. The maximum envelope is the volume of space encompassing the maximum designed movement of ALL robot parts, including the end of arm tooling, work piece and attachments.



WARNING: Voltage Hazard

This equipment is powered by alternating current, as specified on the machine serial tag and data plate.

Device must be properly grounded. Improper grounding can result in severe personal injury and erratic machine operation.

Always disconnect and lock out the incoming main power source to the sprue picker before performing non-standard operating procedures such as routine maintenance. Only qualified personnel should perform troubleshooting procedures that require access to the electrical enclosure while power is on.

All wiring, disconnects, and fuses should be installed by qualified electrical technicians in accordance with electrical codes in your region. Always maintain a safe ground. Do not operate the equipment at power levels other than what is specified on the machine serial plate.



WARNING: High speed moving parts.

Do not enter maximum envelope area while machine is operating. The maximum envelope is the volume of space encompassing the maximum designed movement of ALL robot parts, including the end of arm tooling, work piece and attachments.

Do not operate machine unless interlocks/safety devices are in place and function properly.

Sprue picker may drop load. Do not walk under robot/ load. Failure to follow instructions could result in injury.

PREVENTATIVE MAINTENANCE SCHEDULE

To maintain the best performance, follow this maintenance schedule.

● Daily

- Inspecting filter regulator unit**
Check the bowl for water and contamination and for correct pressure.
- Checking hoses and cables**
Check for kinks, cuts, and tears. Replace as needed.
- Inspecting shock absorbers and cushions**
Make sure they are operating smoothly.
- Checking gripper return spring**
Check that the gripper return spring is operating properly.
- Checking residue buildup**
Inspect the shafts and gripper for buildup of plastic residue. Clean as necessary.
- Checking interlock functions**
Make sure the interlock functions are working properly.
- Checking part verification**
Check that the parts verification is working properly.

● Weekly, or as often as needed.

- Inspecting fittings and mounting hardware**
Check all fittings, screws, and component mounting hardware for tightness. Tighten as needed.
- Checking gripper mounting screw**
Check the gripper mounting screw for tightness. Tighten as needed.
- Inspecting grease fittings**
Check grease fittings and grease with lithium soap grease No. 1 or 2, as needed.
- Checking the safety latch cylinder**
Make sure the safety latch cylinder is working properly.
- Testing the Emergency Stop button**
Verify that the emergency stop works properly.

PREVENTATIVE MAINTENANCE SCHEDULE

- Checking angle of rotation**
Check for correct angle of rotation of the arm. Adjust as necessary.
- Checking timer settings**
Check that settings have not changed. Adjust as needed.
- Verifying sequence**
Check that sprue picker is performing the correct sequences. Correct as needed.

● Monthly

- Inspecting the filter regulator**
Check that the filter regulator is set at the correct pressure. Check the filter and clean or replace it as needed.
- Checking the solenoid valves**
Check that the solenoid valves are working properly. Replace as needed.
- Inspecting the gripper for wear**
Check the gripper fingers for wear. Replace as needed.
- Checking the exhaust filter**
Check the filter and clean or replace it as needed.
- Examining the suction cups**
If equipped with end-of-arm tooling, inspect the suction cups and replace if worn or damaged.
- Inspecting electrical terminals**
Check all electrical terminals for tightness; adjust as needed. See Checking Electrical Connections, page 5-6.
- Checking all electrical cables**
Inspect all electrical cables for cuts, burns, and abrasions. Replace as needed.
- Inspecting hand pendant display**
Check to make sure no LCD display is functioning correctly. Replace as needed.

CHECKING ELECTRICAL CONNECTIONS



WARNING: Electrical hazard

Before performing any work on this product, disconnect and lock out electrical power sources to prevent injury from unexpected energization or start-up.



WARNING: Improper installation, operation, or servicing may result in equipment damage or personal injury.

This equipment should only be installed, adjusted, and serviced by qualified technical personnel who are familiar with the construction, operation, and potential hazards of this type of machine.

All wiring, disconnects, and fuses should be installed by qualified electrical technicians in accordance with electrical codes in your region. Always maintain a safe ground. Do not operate the equipment at power levels other than what is specified on the machine serial tag and data plate.

Electrical Diagrams are in the Appendix, beginning on page A-9.

- 1 Be sure the main power is disconnected** and the sprue picker is locked out. Always disconnect and lock out the main power source before opening the unit or servicing.
- 2 Open the electrical enclosure.**
- 3 Inspect all wires and connections.**
Look for loose wires, burned contacts, and signs of overheated wires. Have a qualified electrician make any necessary repairs or replacements.
- 4 Close the electrical enclosure door.**
- 5 Inspect the exterior power cords and cables.**
Cords should not be crimped, exposed, or rubbing against the frame. If the interface cable or hand pendant cable runs along the floor, make sure it is not positioned where it could rest in pooling water or could be run over and cut by wheels or casters.

TROUBLESHOOTING

- *Before Beginning*6-2
- *A Few Words of Caution*6-2
- *Identifying the Cause of a Problem*6-2
- *Answering an Alarm*6-3
- *The Sprue Picker Does Not Cycle*6-8
- *The Mold is Not Working Properly*6-9
- *The Arm is Not Working Properly*6-10
- *Strip Motion is Not Working*6-11
- *There is No Swing Motion*6-12
- *The Gripper Does Not Work* . . .6-13
- *There is No Vacuum*6-14

BEFORE BEGINNING

You can avoid most problems by following the recommended installation, operation and maintenance procedures outlined in this User Guide. If you have a problem, this section will help you determine the cause and tell you how to fix it.

Find any wiring, parts, and assembly diagrams that were shipped with your equipment. The diagrams will note any custom features or options not covered in this User Guide.

Verify that you have all instructional materials related to the sprue picker. Additional details about troubleshooting and repairing specific components are found in these materials.

Check that you have manuals for other equipment connected in the system. Troubleshooting may require investigating other equipment connected with the sprue picker.

A FEW WORDS OF CAUTION



WARNING: Improper installation, operation, or servicing may result in equipment damage or personal injury.

This equipment should only be installed, adjusted, and serviced by qualified technical personnel who are familiar with the construction, operation, and potential hazards of this type of machine.

All wiring, disconnects, and fuses should be installed and adjusted by qualified electrical technicians in accordance with electrical codes in your region. Always maintain a safe ground. Do not operate the equipment at power levels other than what is specified on the machine serial tag and data plate.



WARNING: Electrical hazard

Before performing maintenance or repairs on this product, disconnect and lock out electrical power sources to prevent injury from unexpected energization or start-up.

IDENTIFYING THE CAUSE OF A PROBLEM

The Troubleshooting section covers problems directly related to the operation and maintenance of the sprue picker. This section does not provide solutions to problems that originate with other equipment. Additional troubleshooting help can be found in manuals supplied with the other equipment.

When an error occurs during operation, the sprue picker stops, an alarm sounds and the error code displays on the hand control. Press the Stop button to silence the alarm. Check this table for a description of the error:

ANSWERING AN ALARM

Error Number	Display	Description
01	ERROR MESSAGE 01 LS SWITCH ERROR LS1 ON LS2 ON CHECK SWITCHES	Error on LS1 or LS2 switch on swing cylinder. Check the switches and cables.
02	ERROR MESSAGE 02 LS3 SWITCH ERROR ARM DOWN LS3 ON CHECK LS3 SWITCH	Error on LS3 main arm up end limit switch, SOL3 arm down solenoid valve, main arm cylinder, or main arm up pneumatic tubing. Check these parts.
03	ERROR MESSAGE 03 LS3 SWITCH ERROR ARM UPS3 OFF CHECK LS3 SWITCH	Error on LS3 main arm up end limit switch. main arm cylinder, main arm up shock absorber, or main arm up pneumatic tubing. Check these parts.
04	ERROR MESSAGE 04 LS6 SWITCH ERROR VAC ON LS6 OFF CHECK LS6 SWITCH	Error on LS6 vacuum switch, vacuum solenoid valve, air leakage, or shortage of the vacuum system pressure. Check these parts.
05	ERROR MESSAGE 05 LS4 SWITCH ERROR GRIP ON LS5 OFF CHECK LS4 SWITCH	Error on LS4 grip limit switch, grip solenoid valve, or gripper. Check these parts. Readjust the location of switch if incorrect.
07	ERROR MESSAGE 07 LS6 SWITCH ERROR VAC ON LS6 ON CHECK LS6 SWITCH	Error on LS6 vacuum switch. Check the switch and cables.
08	ERROR MESSAGE 08 LS4 SWITCH ERROR GRIP OFF LS5 ON CHECK LS4 SWITCH	Error on LS4 grip switch or gripper after grip release. Check these parts. Readjust the location of switch if incorrect.
10	ERROR MESSAGE 10 LS1 OFF ERROR SWING OUT ON CHECK LS1 SWITCH	Error on LS1 swing outward limit switch, swing outward solenoid valve, swing outward pneumatic tubing or swing cylinder. Check parts and readjust LS1 switch position.

ANSWERING AN ALARM

CONT'D

Error Number	Display	Description
11	ERROR MESSAGE 11 LS2 OFF ERROR SWING IN ON CHECK LS2 SWITCH	Error on LS2 swing inward limit switch, swing inward solenoid valve, swing inward pneumatic tubing, or swing cylinder. Check these parts and readjust the LS2 switch position.
12	ERROR MESSAGE 12 LS4 ON ERROR GRIP ON LS4 ON CHECK LS4 SWITCH	Error on program setting (FUNC. 02 setting) or LS4 grip limit switch. Check settings and switch.
14	ERROR MESSAGE 14 LS SWITCH ERROR LS3 ON LSD ON CHECK SWITCHES	Error on LS3 main arm up end limit switch or LSD main arm down end limit switch. Check the switches.
31	ERROR MESSAGE 31 LS3 OFF ERROR ROBOT NOT HOME CHECK LS3 SWITCH	Error on LS3 main arm up end limit switch, main arm, main arm up end shock absorber , or main arm up pneumatic tubing. Check these parts.
32	ERROR MESSAGE 32 LS2 OFF ERROR ROBOT NOT HOME CHECK LS2 SWITCH	Error on LS2 swing inward limit switch, swing cylinder, or swing inward pneumatic tubing. Check these parts.
33	ERROR MESSAGE 33 LS1 ON ERROR ROBOT NOT HOME CHECK LS1 SWITCH	Error on LS1 swing outward limit switch, swing cylinder, or swing outward pneumatic tubing. Check these parts.
35	ERROR MESSAGE 35 INTERFACE ERROR NO MOLD OPEN SIG CHECK MOLD OPEN	Error on interface between robot and press. Check interface cable/connector (wire # between 2 and 16), mold open switch on press, and cable/connector between robot and hand control (wire # 29 LSO).
36	ERROR MESSAGE 36 PROGRAM ERROR PRESS AUTO OR STOP	No logical error on this message. Press Auto or Stop button to reset.

ANSWERING AN ALARM CONT'D

Error Number	Display	Description
37	ERROR MESSAGE 37 INTERFACE ERROR SAFETY GATE OFF CHECK SIGNAL	Error displays during Manual mode. Check that the safety gate is fully closed, safety gate switch on press, interface cable/connector (wire # between 3 and 11), and cable/connector between robot and hand control (wire # 28 LSG).
38	ERROR MESSAGE 38 PROGRAM ERROR NO PROGRAM SELECT PROGRAM	No logical error. Input a program.
39	ERROR MESSAGE 39 LS4 ON ERROR IN HOME GRIP ON CHECK LS4 SWITCH	Error displays during Auto mode. Arm is in the home position, LS1, LS3 and LS4 are on. Check LS4 grip switch, gripper, and robot home position.
41	ERROR MESSAGE 41 LS6 ON ERROR IN HOME VAC ON CHECK LS6 SWITCH	Error displays during Auto mode. Arm is in the home position, LS1, LS3 and LS6 are on (vacuum switch is off but sensor is on). Check LS6 switch and robot home position.
45	ERROR MESSAGE 45 ARM DOWN VALVE ON NO SWING CHECK ARM VALVE	Error displays during Manual or Teach mode. Arm down valve is on and trying to swing. Check program input is correct, LS1 and LS2 swing outward/inward switches, and main arm down solenoid.
47	ERROR MESSAGE 47 ARM NOT UP LS3 OFF NO SWING CHECK LS3 SWITCH	LS3 switch is off and robot is trying to swing in/out. Check error on LS3 main arm up end limit switch, program input, air pressure, main arm down solenoid.
51	ERROR MESSAGE 51 LS SWITCH ERROR LS1 OFF LS2 OFF CHECK SWITCHES	Error on LS1 or LS2 switches, air leakage from main arm cylinder or swing cylinder. Check parts and air pressure.
52	ERROR MESSAGE 52 LS4 SWITCH ON BEFORE ARM DOWN CHECK LS4 SWITCH	Program setting error. Reprogram with correct settings.

ANSWERING AN ALARM

CONT'D

Error Number	Display	Description
54	ERROR MESSAGE 54 LS6 ON BEFORE ARM DOWN CHECK LS6 SWITCH	Program setting error. Reprogram with correct settings.
55	ERROR MESSAGE 55 MOLD OPEN OFF BEFORE ARM DOWN CHECK SIGNAL	Error displays during Auto mode. Check interface cable/connector (wire # between 2 and 16), mold open switch on press, and cable/connector between robot and hand control (wire #29 LSO).
57	ERROR MESSAGE 57 INTERFACE ERROR SAFETY GATE OFF CHECK GATE SIG	Safety gate signal lost during main arm down motion. Check safety gate closed, safety gate switch on press, interface cable/connector (wire # between 3 and 11), and cable /connector between robot and hand control (wire #28 LSG).
58	ERROR MESSAGE 58 INTERFACE ERROR SAFETY GATE OFF CHECK GATE SIG	Error on safety gate signal. Check safety gate closed, safety gate switch on press, interface cable/connector (wire # between 3 and 11), and cable /connector between robot and hand control (wire #28 LSG).
59	ERROR MESSAGE 59 NO MOLD OPEN SIGNAL CHECK IMM	Timer error waiting for mold open signal; whole cycle time counted. Check cycle time settings.
60	ERROR MESSAGE 60 INTERFACE ERROR MOLD OPEN LOST CHECK SIGNAL	Error displays during Auto mode or Teach mode. Check interface cable/connector (wire # between 2 and 16), and cable /connector between robot and hand control (wire #29 LSO).

ANSWERING AN ALARM CONT'D

Error Number	Display	Description
62	ERROR MESSAGE 62 INTERFACE ERROR EMERGENCY STOP ON CHECK SIGNAL	Error on emergency stop button on robot or press. Release the button on the hand control and check the switches.
63	ERROR MESSAGE 63 PROGRAM ERROR PRESS AUTO OR STOP	No logical error on this message. Press Auto or Stop button to reset.
64	ERROR MESSAGE 64 INTERFACE ERROR NO MOLD CLOSE CHECK SIGNAL	Error on interface between robot and press. Check interface cable/connector (wire # between 2 and 16), mold open switch on press, and cable/connector between robot and hand control (wire #26 LSI).
65	ERROR MESSAGE 65 INTERFACE ERROR NO SAFETY GATE CHECK SIGNAL	Error displays during Auto mode. Check safety gate closed, safety gate switch on press, interface cable/connector (wire # between 3 and 11), and cable /connector between robot and hand control (wire #28 LSG).
66	ERROR MESSAGE 66 INTERFACE ERROR NO PRESS AUTO CHECK SIGNAL	Error displays during Auto mode. Check the auto mode switch on press, interface cable/connector (wire # between 10 and 16) and cable/connector between robot and hand control (wire # 27 LSA).

THE SPRUE PICKER DOES NOT CYCLE

There are several reasons the sprue picker does not cycle. You need to check electrical connections, fuses, and the automatic setting.

Symptom	Possible cause	Solution
◆ The sprue picker does not cycle.	Electrical connections are not correct.	Check that: <ul style="list-style-type: none"><input type="checkbox"/> The sprue picker is plugged into a power source.<input type="checkbox"/> The main power source is on.<input type="checkbox"/> The interface cables are connected.<input type="checkbox"/> The fuses are good.<input type="checkbox"/> The power to the press is on.
◆ Automatic operation is not available.	The press is not in auto.	Check that the interface wiring is properly connected.
	The sprue picker is not in Home position.	Return the sprue picker to Home using the manual button on the hand control.

The common problems you will see with the mold are that it will not close or it will not open. You need to check settings and electrical connections.

THE MOLD IS NOT WORKING PROPERLY

Symptom	Possible cause	Solution
◆ The mold does not close.	The arm is not in the full up position, or at the swing outward end.	Check the Arm Up (LS-3) and Swing Outward End (LS-1) switches and adjust as needed.
	The safety interlock is on.	Check the output and wiring.
	The part verification signal is not working.	Check that the part verification is on. Replace the switch if necessary.
	The optional cycle start signal is not working.	Check the output and wiring.
◆ The mold does not open.	The arm is not in the full up position, or at the swing outward end.	Check the Arm Up (LS-3) and Swing Outward End (LS-1) switches and adjust as needed.
	The safety interlock is on.	Check the output and wiring.

THE ARM IS NOT WORKING PROPERLY

The problems you will see with the arm is that it will not extend or retract properly. Check electrical wiring, switches, valves, and air lines.

Symptom	Possible cause	Solution
◆ There is no arm extension (no arm down).	There is no air pressure.	Check air supply to the sprue picker. Check for leaks.
	The mold is not fully open.	Check that the interface wiring is correct.
	The sprue picker is not swung fully in or fully out.	Check the LS-1 and LS-2 switches and adjust as necessary.
	Vertical stroke adjustment block is set too low.	Loosen stroke adjustment block and set higher to correct stroke.
	The arm down flow control is shut off.	Adjust the down speed control; replace as needed.
	The main arm solenoid valve is not functioning.	Replace the main arm solenoid valve.
	The air lines/seals are damaged or leaking.	Check air lines and seals; replace as needed.
◆ There is no arm retraction (no arm up).	There is no air pressure.	Check air supply to the sprue picker.
	The up solenoid is not functioning.	Replace the up solenoid valve.

When the strip is not working properly, it does not move forward or backward. You need to adjust the strip speed control, replace the valve, or check the air lines.

STRIP MOTION IS NOT WORKING

Symptom	Possible cause	Solution
◆ There is no strip forward motion.	There is no air pressure.	Check air supply to the sprue picker. Check for leaks.
	Strip stroke adjustment set too short.	Check strip stroke adjustment for proper distance.
	The strip forward speed control is shut off.	Adjust the strip forward speed control; replace as needed.
	The strip valve is not functioning.	Check the strip valve and replace as needed.
	The air lines/seals are damaged or leaking.	Check air lines and seals and replace as needed.
◆ There is not strip backward motion.	There is no air pressure.	Check air supply to the sprue picker. Check for leaks.
	Strip stroke adjustment set too short.	Check strip stroke adjustment for proper distance.
	The strip backward speed control is shut off.	Adjust the strip backward speed control; replace as needed.
	The strip valve is not functioning.	Check the strip valve and replace as needed.
	The air lines/seals are damaged or leaking.	Check air lines and seals and replace as needed.

THERE IS NO SWING MOTION

Causes for the swing not moving are due to switches and air lines. Check switches and check for air leaks.

Symptom	Possible cause	Solution
◆ The swing does not move.	There is no air pressure.	Check the air supply to the sprue picker.
	The arm is not in the full up position.	Check the arm up switch and adjust as needed.
	The swing inhibitor devices used during shipping is still attached.	Remove the swing bracket and the screws used during shipping. See page 3-5.
	Part verification is not on (during Auto mode).	Check and adjust the verification switches as needed.
	The swing flow controls are shut off.	Adjust the swing speed control; replace as needed.
	The air lines/seals are damaged or leaking.	Check air lines and seals and replace as needed.

When the gripper does not grab the sprue, check the solenoid, switches, and the air lines.

THE GRIPPER DOES NOT WORK

Symptom	Possible cause	Solution
◆ The gripper does not work.	There is no air pressure.	Check the air supply; adjust as needed.
	The arm is not in mold or extended over gate (during Manual mode).	Extend the arm in the mold or over gate area.
	The grip solenoid is not working properly.	Replace the grip solenoid.
	The air lines/seals are damaged or leaking.	Check air lines and seals and replace as needed.
	The part/sprue is sticking to the mold.	Adjust the ejector stroke. Correct the mold problem.
	Main grip is not selected in Program mode.	Place grip on in Program mode.
	Gripper is faulty.	Check gripper for broken spring or cracked housing. Replace as needed.

THERE IS NO VACUUM

When the vacuum is not working, check settings, air line problems, and bad solenoids.

Symptom	Possible cause	Solution
◆ There is no vacuum.	The air pressure is incorrect.	Check the air pressure. Adjust as needed.
	The mode setting is incorrect.	Set the mode for vacuum.
	The vacuum solenoid is not working properly.	Replace the vacuum solenoid.
	The air lines/seals are damaged or leaking.	Check the air lines and seals and replace as needed.
	The part/sprue is sticking to the mold.	Adjust the ejector stroke. Correct the mold problem.

Conair has made the largest investment in customer support in the plastics industry. Our service experts are available to help with any problem you might have installing and operating your equipment. Your Conair sales representative also can help analyze the nature of your problem, assuring that it did not result from misapplication or improper use.

WE'RE HERE TO HELP

To contact Customer Service personnel, call:



From outside the United States, call: 814-437-6861

HOW TO CONTACT CUSTOMER SERVICE

You can commission Conair service personnel to provide on-site service by contacting the Customer Service Department. Standard rates include an on-site hourly rate, with a one-day minimum plus expenses.

If you do have a problem, please complete the following checklist before calling Conair:

- Make sure you have all model, serial and parts list numbers for your particular equipment. Service personnel will need this information to assist you.
- Make sure power is supplied to the equipment.
- Make sure that all connectors and wires within and between the sprue picker and related components have been installed correctly.
- Check the troubleshooting guide of this manual for a solution.
- Thoroughly examine the instruction manual(s) for associated equipment, especially controls. Each manual may have its own troubleshooting guide to help you.
- Check that the equipment has been operated as described in this manual.
- Check accompanying schematic drawings for information on special considerations.

BEFORE YOU CALL ...

Additional manuals and prints for your Conair equipment may be ordered through the Customer Service or Parts Departments for a nominal fee.

EQUIPMENT GUARANTEE

Conair guarantees the machinery and equipment on this order, for a period as defined in the quotation from date of shipment, against defects in material and workmanship under the normal use and service for which it was recommended (except for parts that are typically replaced after normal usage, such as filters, liner plates, etc.). Conair's guarantee is limited to repairing or replacing, at our option, the part or parts determined by us to be defective after examination. The customer assumes the cost of transportation of the part or parts to and from the factory.

PERFORMANCE WARRANTY

Conair warrants that this equipment will perform at or above the ratings stated in specific quotations covering the equipment or as detailed in engineering specifications, provided the equipment is applied, installed, operated and maintained in the recommended manner as outlined in our quotation or specifications.

Should performance not meet warranted levels, Conair at its discretion will exercise one of the following options:

- Inspect the equipment and perform alterations or adjustments to satisfy performance claims. (Charges for such inspections and corrections will be waived unless failure to meet warranty is due to misapplication, improper installation, poor maintenance practices or improper operation.)
- Replace the original equipment with other Conair equipment that will meet original performance claims at no extra cost to the customer.
- Refund the invoiced cost to the customer. Credit is subject to prior notice by the customer at which time a Return Goods Authorization Number (RGA) will be issued by Conair's Service Department. Returned equipment must be well crated and in proper operating condition, including all parts. Returns must be prepaid.

Purchaser must notify Conair in writing of any claim and provide a customer receipt and other evidence that a claim is being made.

WARRANTY LIMITATIONS

Except for the Equipment Guarantee and Performance Warranty stated above, Conair disclaims all other warranties with respect to the equipment, express or implied, arising by operation of law, course of dealing, usage of trade or otherwise, including but not limited to the implied warranties of merchantability and fitness for a particular purpose.

You can add a second descent slowdown circuit to an MXR model sprue picker. The two valves that are part of the second descent slowdown circuit are the vertical valve and the swing valve.

ADDING A SECOND DESCENT

The second descent slowdown valve is an air actuated valve. It is actuated by the swing motion. When the swing motion swings out, the pressure used to swing the arm out energizes the slowdown valve. When the arm descends in the swing out position, the exhaust of the vertical is diverted through the second descent slowdown valve through a metering valve.

This metering valve creates a second slower speed. When the arm swings back in, the pressure to the second descent slowdown valve is no longer present and the air for the vertical cylinder goes straight through the second descent slowdown valve without being metered.



Warning

The air supply to the sprue picker must be disconnected and drained from the machine before doing any installation or maintenance. Failure to heed this warning may result in personal injury.

ADDING A SECOND DESCENT: PREPARATION

To add a second descent slowdown circuit to and MXR sprue picker:

- 1** Shut off the air supply to the sprue picker.
- 2** Disconnect the air supply to the sprue picker.
- 3** Apply thread sealer to all unsealed threads.
- 4** Cut the tubing and attach.

Cut

Tubing	Length, in.	Location
MX60 to MX150		
8mm	5	Slowdown valve to Flow Control valve
8mm	5	Flow Control valve to Quick Exhaust valve
8mm	11.25	Slowdown valve to Quick Exhaust valve
4mm	11.5	Slowdown valve to Swing Arm
6mm	---	Slowdown valve to Main cylinder
MX250 to MX550		
8mm	5	Slowdown valve to Flow Control valve
8mm	5	Flow Control valve to Quick Exhaust valve
8mm	11.25	Slowdown valve to Quick Exhaust valve
6mm	11.5	Slowdown valve to Swing Arm
8mm	---	Slowdown valve to Main cylinder
MX350T to MX550T		
8mm	5	Slowdown valve to Flow Control valve
8mm	5	Flow Control valve to Quick Exhaust valve
8mm	11.25	Slowdown valve to Quick Exhaust valve
6mm	11.5	Slowdown valve to Swing Arm
8mm	---	Slowdown valve to Main cylinder

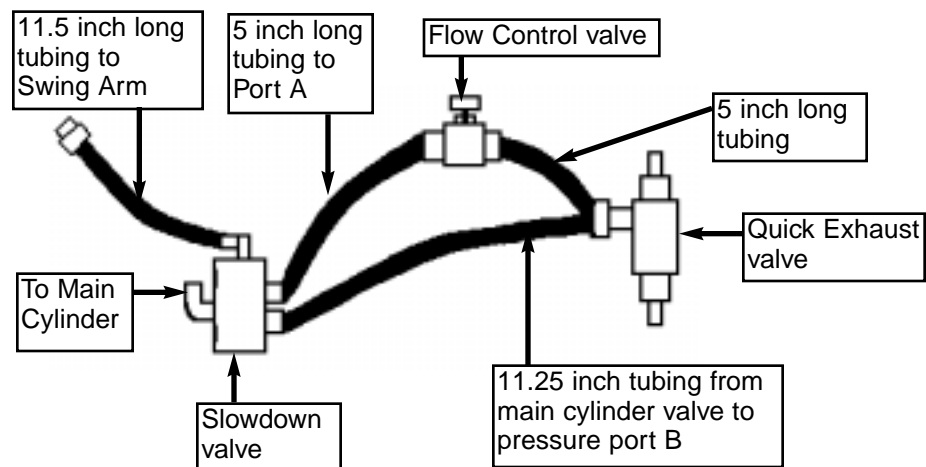

ADDING A SECOND DESCENT: ATTACHING

- 1 Mark the template on the junction box cover.** Remove the junction box cover and, using the template that comes with the second descent, mark the template on the junction box.

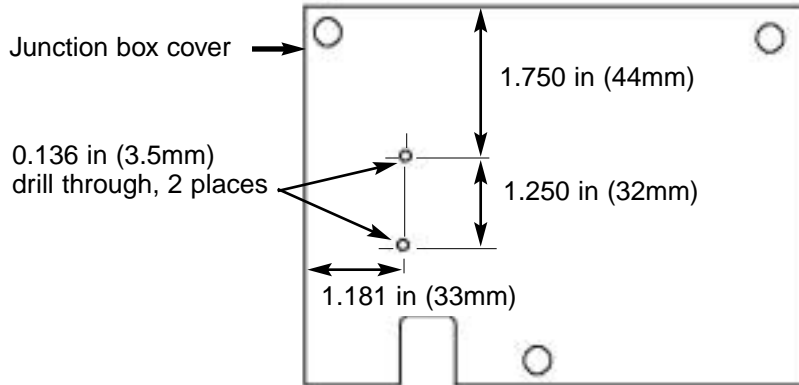

- 2 Drill the holes.**
- 3 Mount the valve to the junction box** below the valve assembly (see picture) using the mounting screws.

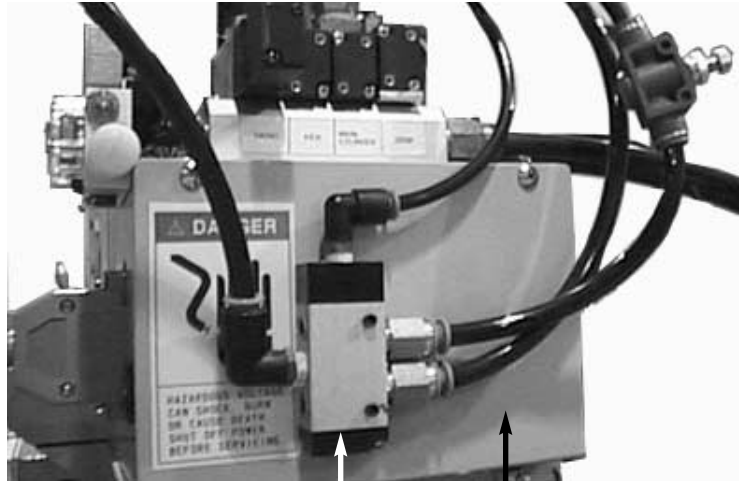

Mark template in this area and mount here.

Junction box

- 4 Replace the cover.**

ADDING A SECOND DESCENT: CONNECTING QUICK EXHAUST

- 1** Disconnect the tubing from the main vertical arm at the manifold connection.
- 2** Connect this hose to the pressure port on the slowdown valve.
- 3** Remove flow control and fitting from main cylinder valve on the manifold at port B.
- 4** Remove Y fitting from quick exhaust valve, supplied with kit; apply thread sealer.
- 5** Thread quick exhaust valve into main cylinder at port B. Be careful to not overtighten. Align port as shown.
- 6** Reconnect Y fitting to quick-exhaust valve and reconnect air lines to Y fitting.

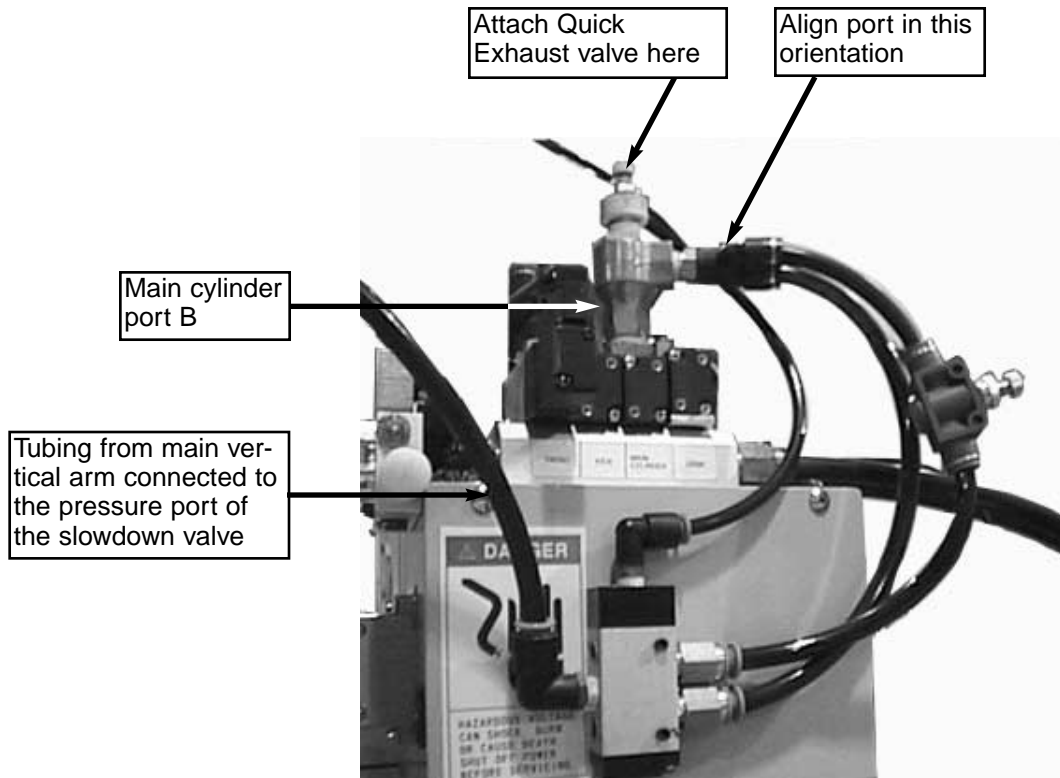

-
- 1** Locate Swing valve port A.
 - 2** Cut tubing about 4 inches (102mm) from the fitting.
 - 3** Insert Y fitting.
 - 4** Connect air line from top of slowdown valve into Y fitting.

ADDING A SECOND DESCENT: CONNECTING SWING VALVE

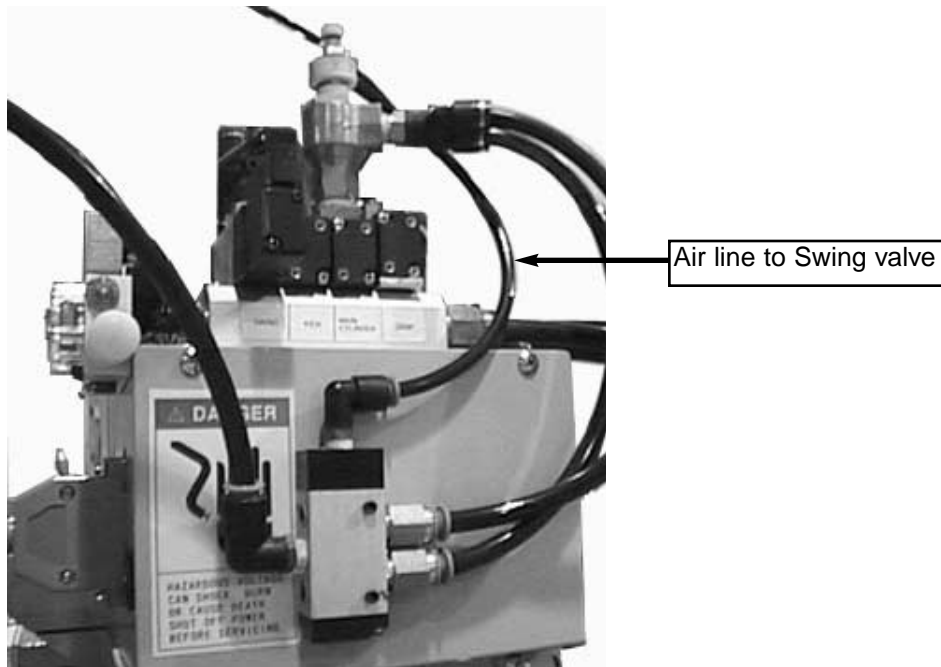

ADDING A SECOND DESCENT: ADJUSTMENTS

To adjust the speed of the second descent slowdown valve:

- 1 Turn Knob A (overall speed)**
Turn Knob A clockwise to slow the speed of the arm and counterclockwise to increase the speed of the arm.
- 2 Turn Knob B (second descent speed)**
To adjust the speed of the arm for second descent, turn Knob B clockwise to slow second descent speed and counterclockwise to increase second descent.

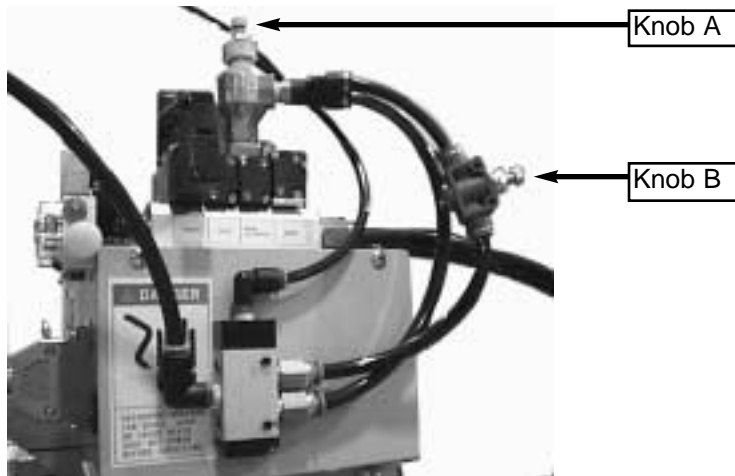

System Configuration CD-EM1 Control

ELECTRICAL DIAGRAMS

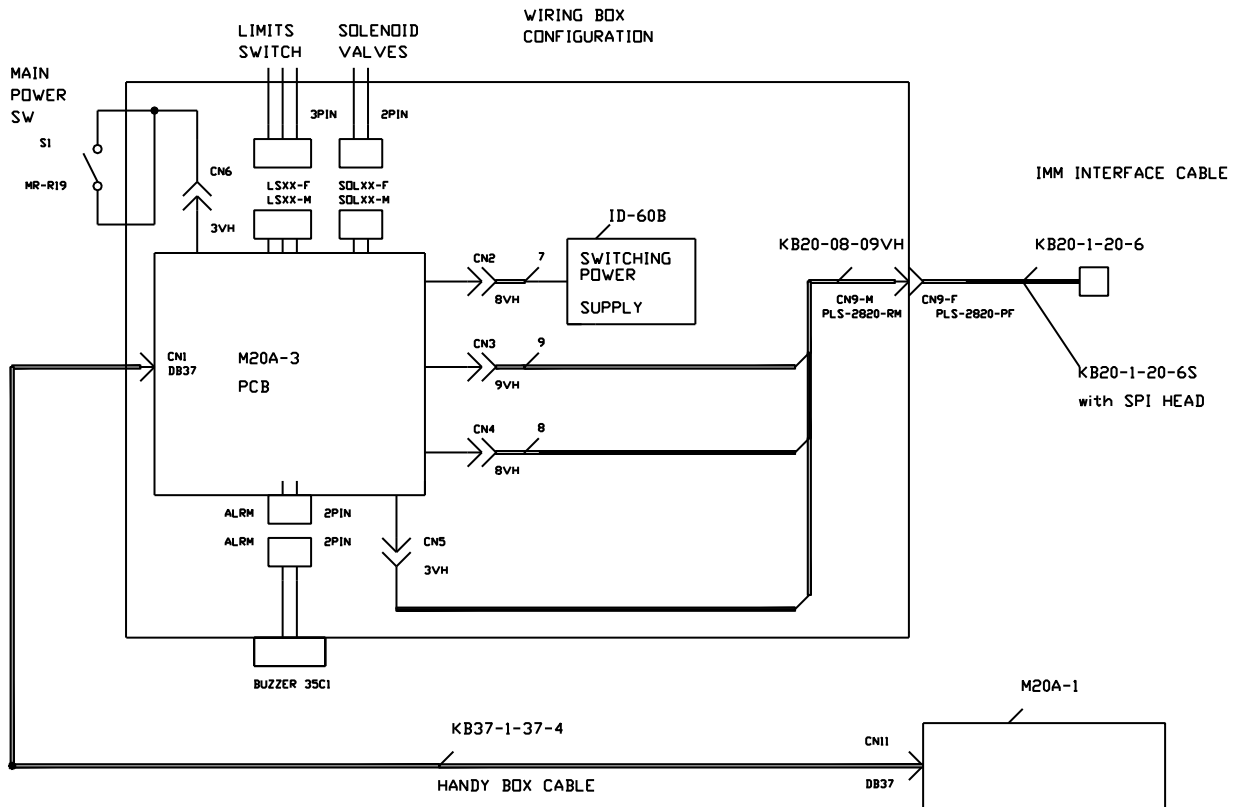

ELECTRICAL DIAGRAMS

Sprue Picker and IMM Interface CD-EM1 Control

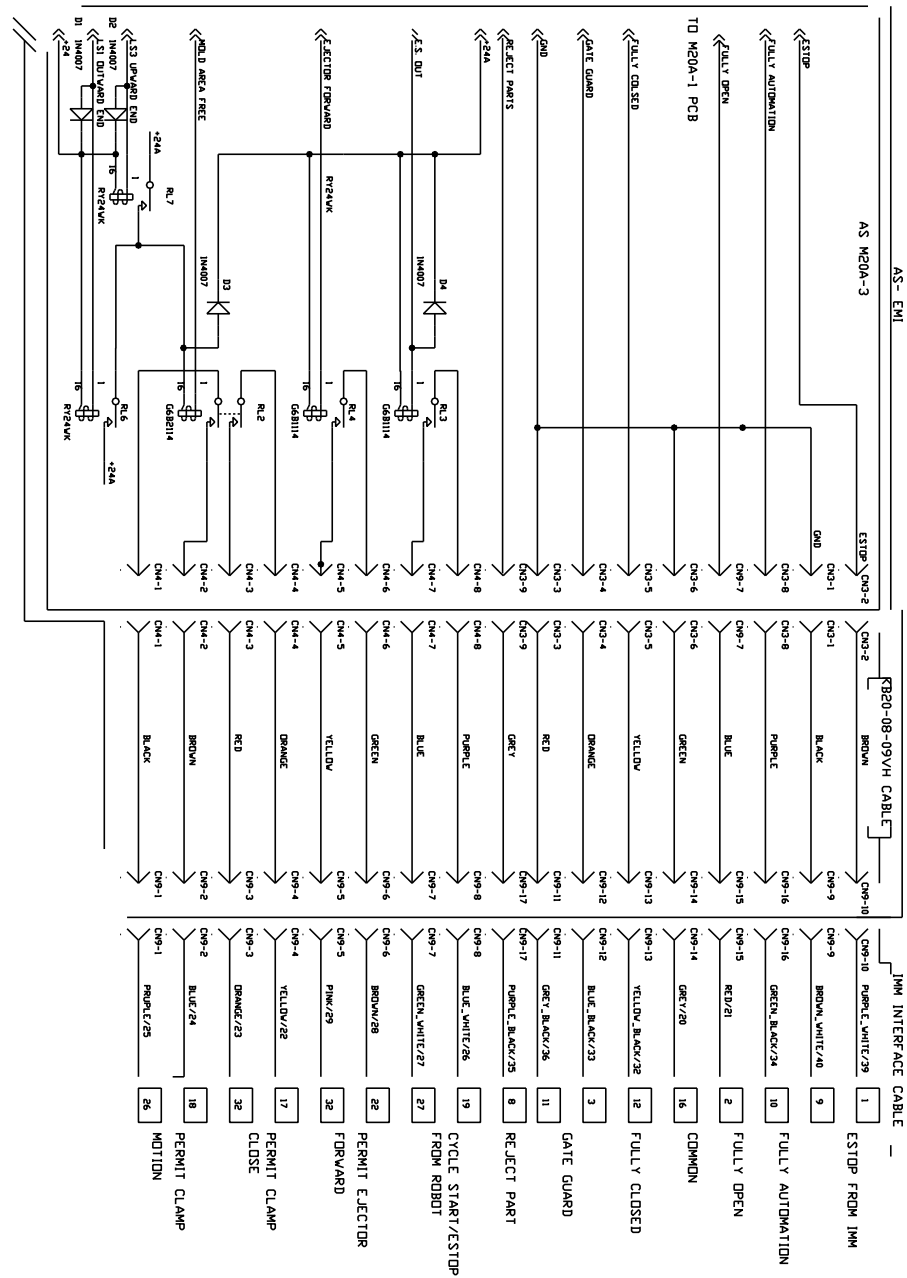

CAUTION: Equipment hazard.
Do not plug an MX Sprue Picker control into an interface wired for an MXR Sprue Picker. Damage will occur! Call Conair Service if you are unsure or have any questions.

Solenoid and Limit Switch Wiring CD-EM1 Control

ELECTRICAL DIAGRAMS

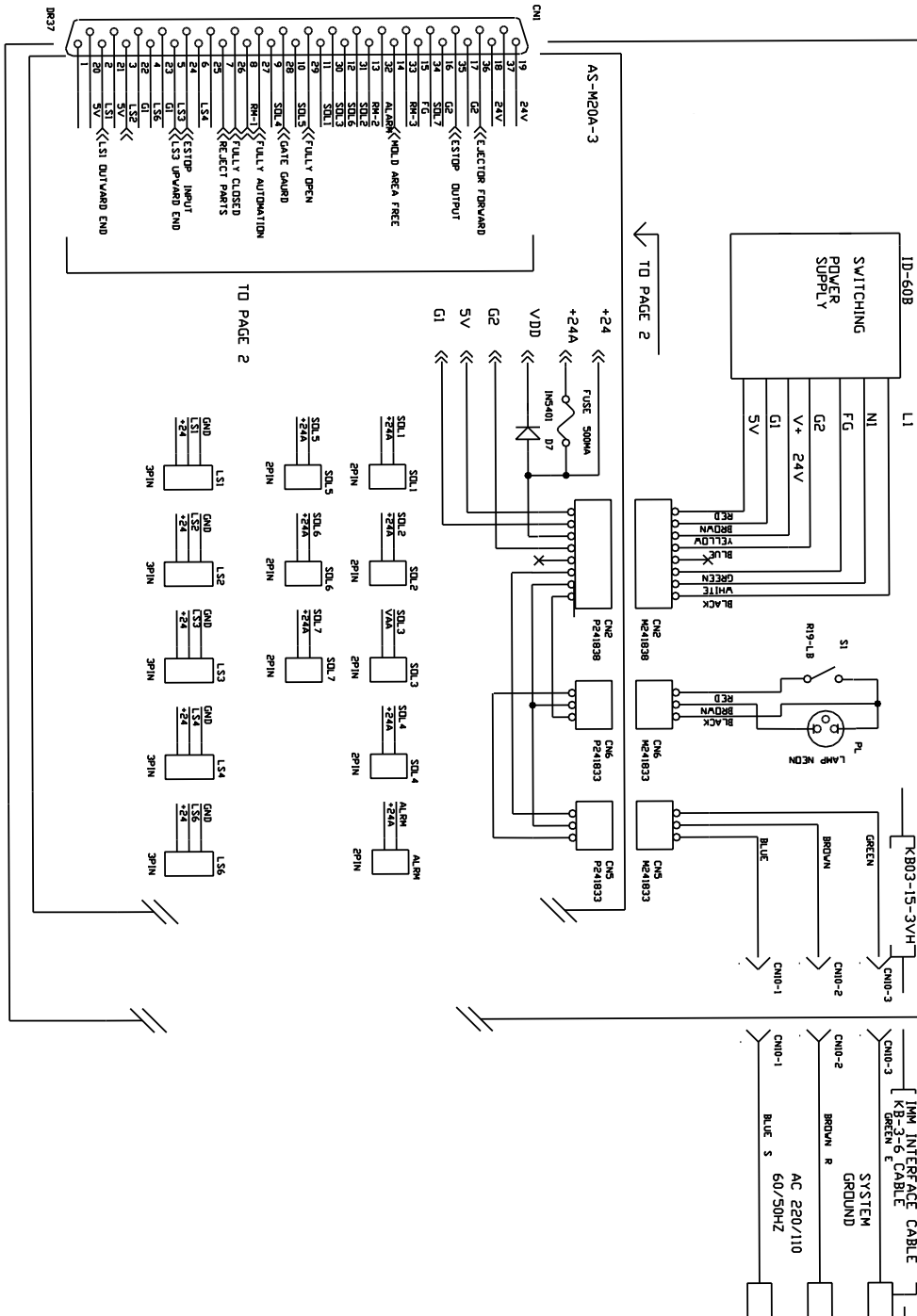

ELECTRICAL DIAGRAMS

Relay and IMM Interface CD-EM1 Control

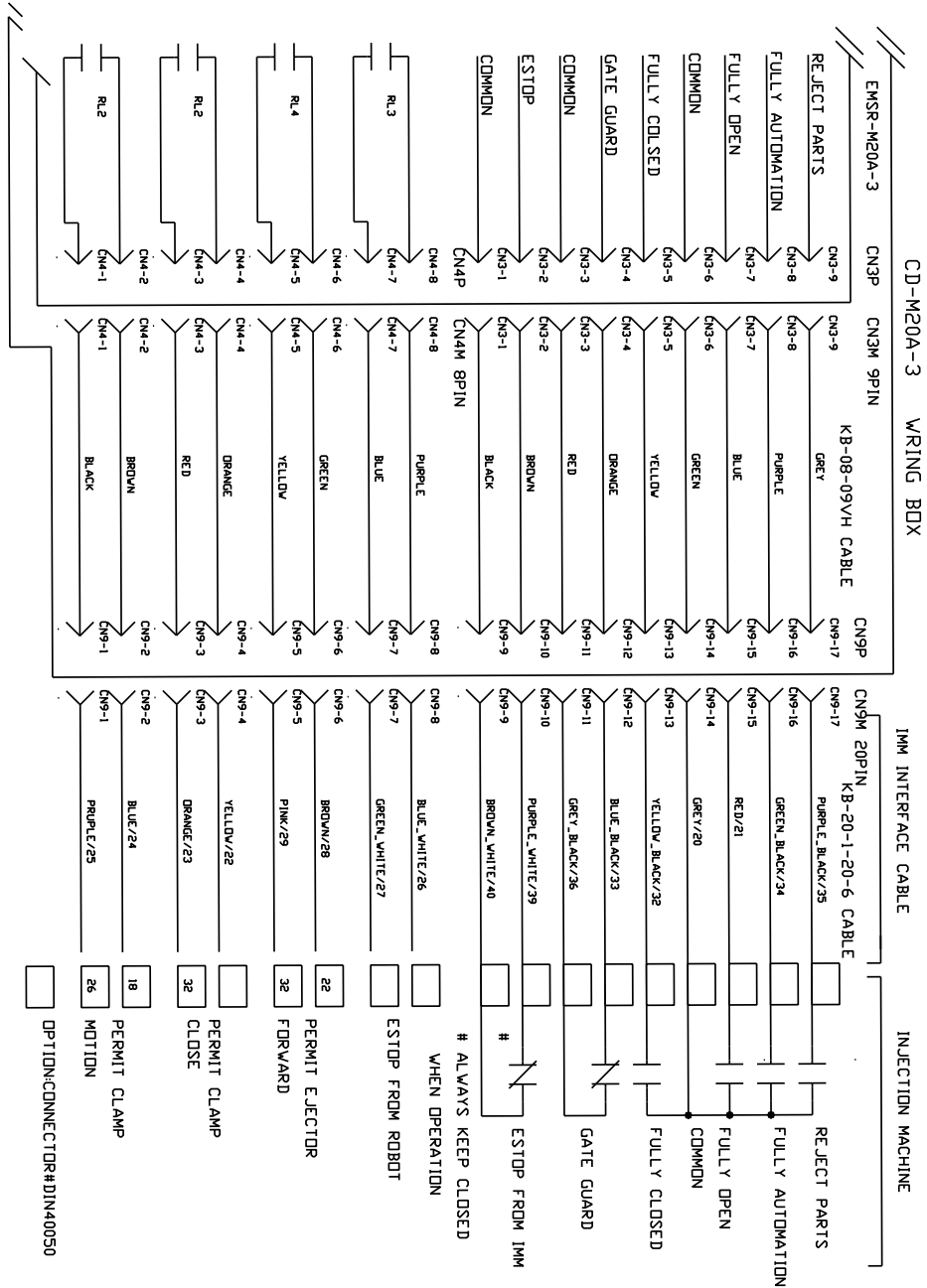

CAUTION: Equipment hazard.

Do not plug an MX Sprue Picker control into an interface wired for an MXR Sprue Picker. Damage will occur! Call Conair Service if you are unsure or have any questions.

The motion sequence is the movement pattern that the arm travels. There are 12 motion sequences (modules) pre-programmed into the hand control.

MOTION SEQUENCES

Motion Sequence	Movement Steps:	Motion Sequence	Movement Steps:
00	<ol style="list-style-type: none"> 1. Arm descend 2. Strip forward 3. Vacuum on 4. Strip backward 5. Arm retract 6. Swing outward 7. Second arm descent 8. Vacuum off 9. Second arm retract 10. Swing inward 	03	<ol style="list-style-type: none"> 1. Strip forward 2. Arm descend 3. Strip backward 4. Grip on 5. Strip forward 6. Arm retract 7. Swing outward 8. Arm second descend 9. Grip off 10. Second arm retract 11. Swing in
01	<ol style="list-style-type: none"> 1. Arm descend 2. Strip forward 3. Grip on 4. Strip backward 5. Arm retract 6. Swing outward 7. Second arm descent 8. Vacuum off 9. Second arm retract 10. Swing inward 	04	<ol style="list-style-type: none"> 1. Arm descend 2. Strip forward 3. Grip on 4. Strip backward 5. Arm retract 6. Swing outward 7. Second arm descent 8. Grip off 9. Second arm retract 10. Swing in
02	<ol style="list-style-type: none"> 1. Arm descend 2. Grip on 3. Strip forward 4. Arm retract 5. Swing outward 6. Arm second descend 7. Grip off 8. Arm second retract 9. Swing inward 10. Strip backward 	05	<ol style="list-style-type: none"> 1. Strip forward 2. Arm descend 3. Strip backward 4. Grip on 5. Strip forward 6. Grip off 7. Arm retract 8. Strip backward 1. Arm descend 2. Strip forward 3. Grip on 4. Strip backward 5. Grip off 6. Arm retract

MOTION SEQUENCES

Motion Sequence	Movement Steps:	Motion Sequence	Movement Steps:
06	<ol style="list-style-type: none"> 1. Arm descend 2. Strip forward 3. Grip on 4. Strip backward 5. Grip off 6. Arm retract 	09	<ol style="list-style-type: none"> 1. Arm descend 2. Strip forward 3. Grip off 4. Vacuum on 5. Strip backward 6. Arm retract 7. Swing outward 8. Arm second descend 9. Vacuum off 10. Grip off 11. Second arm retract 12. Swing in
07	<ol style="list-style-type: none"> 1. Strip forward 2. Arm descend 3. Grip on 4. Strip backward 5. Grip off 6. Arm retract 	10	<ol style="list-style-type: none"> 1. Arm descend 2. Strip forward 3. Grip off 4. Vacuum on 5. Strip backward 6. Arm retract 7. Swing outward 8. Arm second descend 9. Grip off 10. Strip forward 11. Vacuum off 12. Arm second retract 13. Strip backward 14. Swing in
08	<ol style="list-style-type: none"> 1. Arm descend 2. Grip on 3. Strip forward 4. Grip off 5. Arm retract 6. Strip backward 	11	<ol style="list-style-type: none"> 1. Arm descend 2. Strip forward 3. Grip off 4. Vacuum on 5. Strip backward 6. Arm retract 7. Swing outward 8. Arm second descend 9. Vacuum off 10. Arm second retract 11. Arm third descend 12. Grip off 13. Arm third retract 14. Swing in

PARTS/DIAGRAMS

- **Swing BasePD-2**
- **ValvePD-4**
- **Strip Frame (base unit)PD-6**
- **Strip Frame (strip remote)PD-8**
- **Strip Remote MotorPD-10**
- **Strip CylinderPD-12**
- **Main Arm AssemblyPD-14**
- **Main Arm Assembly
(vertical remote)PD-16**
- **Vertical Remote AssemblyPD-18**
- **Main Cylinder AssemblyPD-20**
- **Main ArmPD-22**
- **Main Arm (vertical remote)PD-24**
- **Wrist RotationPD-26**
- **Gripper AssemblyPD-28**
- **GripperPD-30**
- **Venturi Vacuum KitPD-32**
- **Wrist CylinderPD-34**
- **CD-EM1 ControllerPD-36**

PARTS/LISTS

MODELS MXR-60 AND MXR-150

Swing Base

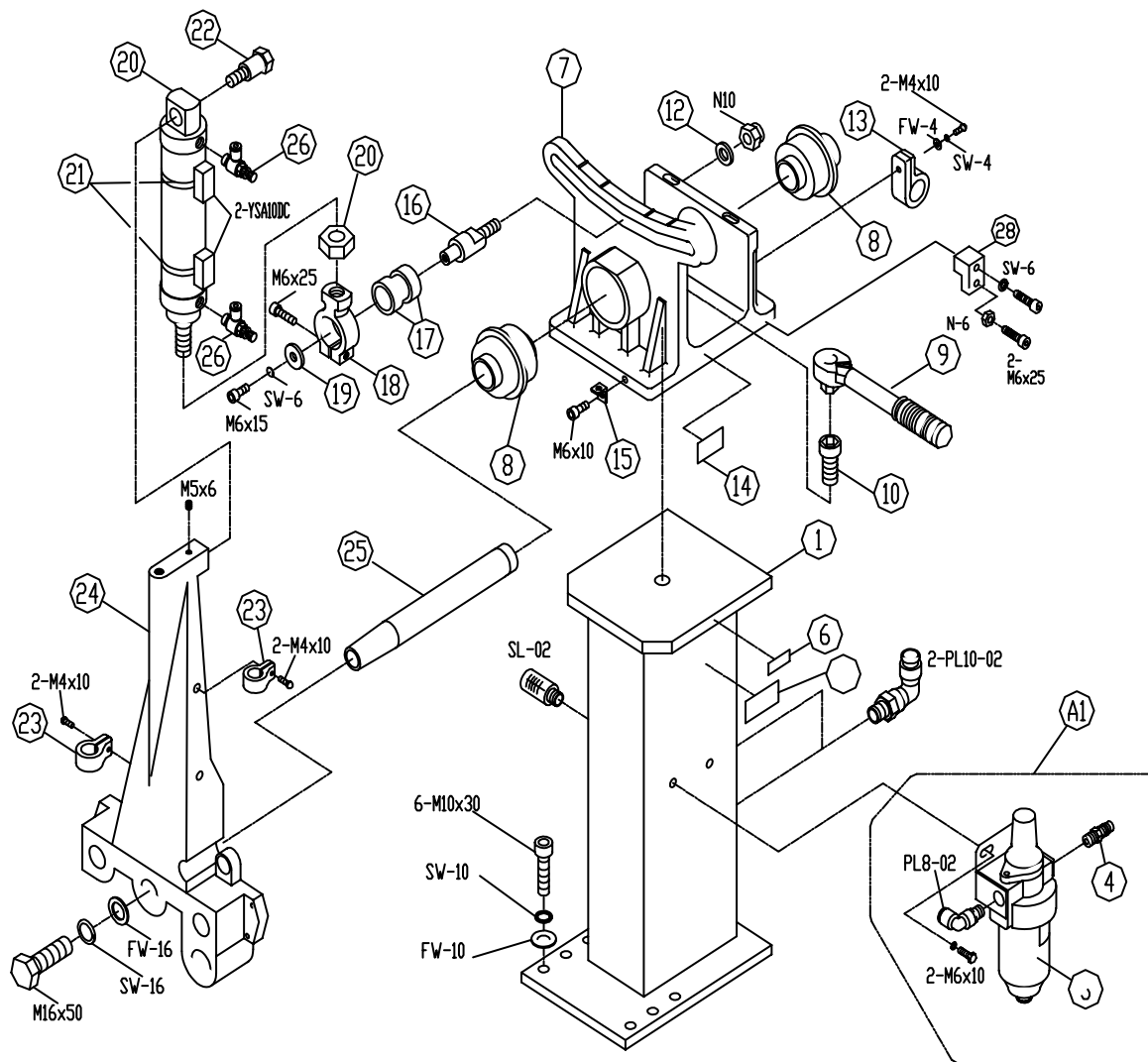

Swing Base - Models MXR-60 and MXR-150

Ref.	Part No.	Description	Quantity
A1	A9010	Filter Assembly	1
1	A0161C	Base	1
3	B08-C2-FRG0	Filter Unit, Wilkerson	1
5	S001	Label, Serial Number	1
6	S003	Seal, Tighten/Loosen Ratchet	1
7	A0191	Support, Strip Frame	1
8	ER205	Bearing, Swing Shaft	2
9	REWE003	Lever, Ratchet	1
10	MX16X50CS	Screw, Pivot Lock	1
12	FW1016	Washer, Lock, Swing Axis	1
13	NK-14N	Vinyl Cord Clip	2
14	S002	Label, Arrow	1
15	A0151	Bracket, Ship, Swing Lock	1
16	A0181	Pin, Adjusting, Swing Angle	1
17	6200Z	Bearing, Pin, Swing	2
18	A0171	Bracket, Bearing, Swing	1
19	A0141	Washer, Flat, 16mm	1
20	DAC40X100	Swing Cylinder	1
21	S004	Label, LS	2
22	A0201	Pin, Clevis, Swing Angle	1
23	NK-8N	Vinyl Cord Clip	4
24	C5015R-C	Arm, Swing	1
25	C0021	Shaft, Swing, 50mm dia.	1
28	1MB0011	Bracket, Stop, Pivot Base	1
	PL8-02	Fitting, Picso	1
	PL10-02	Fitting, Pisco	2
	SL-02	Silencer	1
	7010 06 10	Speed Controller	2
	YSA10DC	Switch, Swing Cylinder	2
	YSA10DC-40A	Band, Fix	2

PARTS/LISTS

MODELS MXR-60 AND MXR-150

Valve

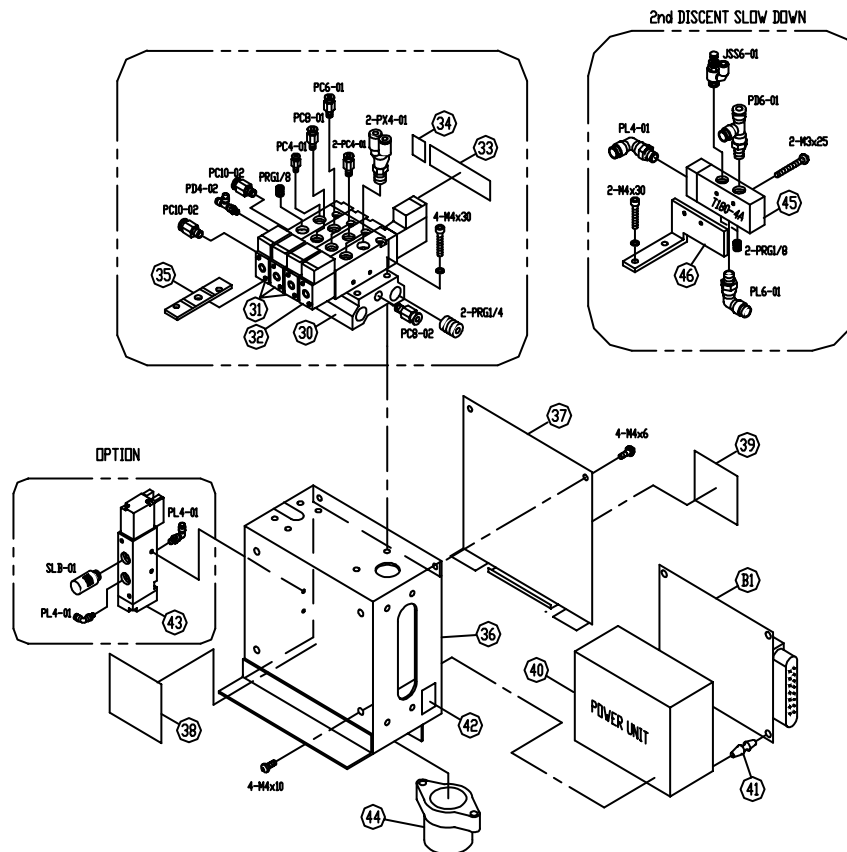

Valve - Models MXR-60 and MXR-150

Ref.	Part No.	Description	Quantity
B1	M20-03	I/O Relay Board, MXR	1
30	180M4F	Valve/Manifold Assembly	1
31	180-4E1	Valve, Koganei	3
32	180-4E2	Valve, Koganei	1
33	S007	Label, Main-Kick-Swing	1
34	S008	Label, Grip	1
35	VC0021	Spacer, Grip Valve	1
36	B1011R-C	Valve Mounting Housing	2
37	B1025R-C	Housing Cover	1
38	S005	Label, Swing Out Direction	2
39	LA001	Label, High Voltage	1
40	ID60B	Power Supply	1
41	CS305	Stud	4
42	MR-R19	Switch, On-Off, OBO	1
43	180-4E1S	Valve, Koganei	1
44	BZ-35C1	Buzzer	2
45	T180-4A	Pilot Valve, Second Descent	1
46	VC0031	Bracket, Valve, Second Descent	1
	PC6-01	Fitting, Pisco	3
	PXG6-4-01	Fitting, Pisco	2
	PC4-01	Fitting, Pisco	2
	PC8-01	Fitting, Pisco	1
	PC8-02	Fitting, Pisco	1
	PC10-02	Fitting, Pisco	2
	PD4-02	Fitting, Pisco	1
	PL6-01	Fitting, Pisco	4
	PD6-01	Fitting, Pisco	4
	PL4-01	Fitting, Pisco	4
	JSS6-01	Speed Controller	4
	PL4-01	Fitting, Pisco	2
	SLB-01	Silencer	1

PARTS/LISTS

MODELS MXR-60 AND MXR-150

Strip Frame (base unit)

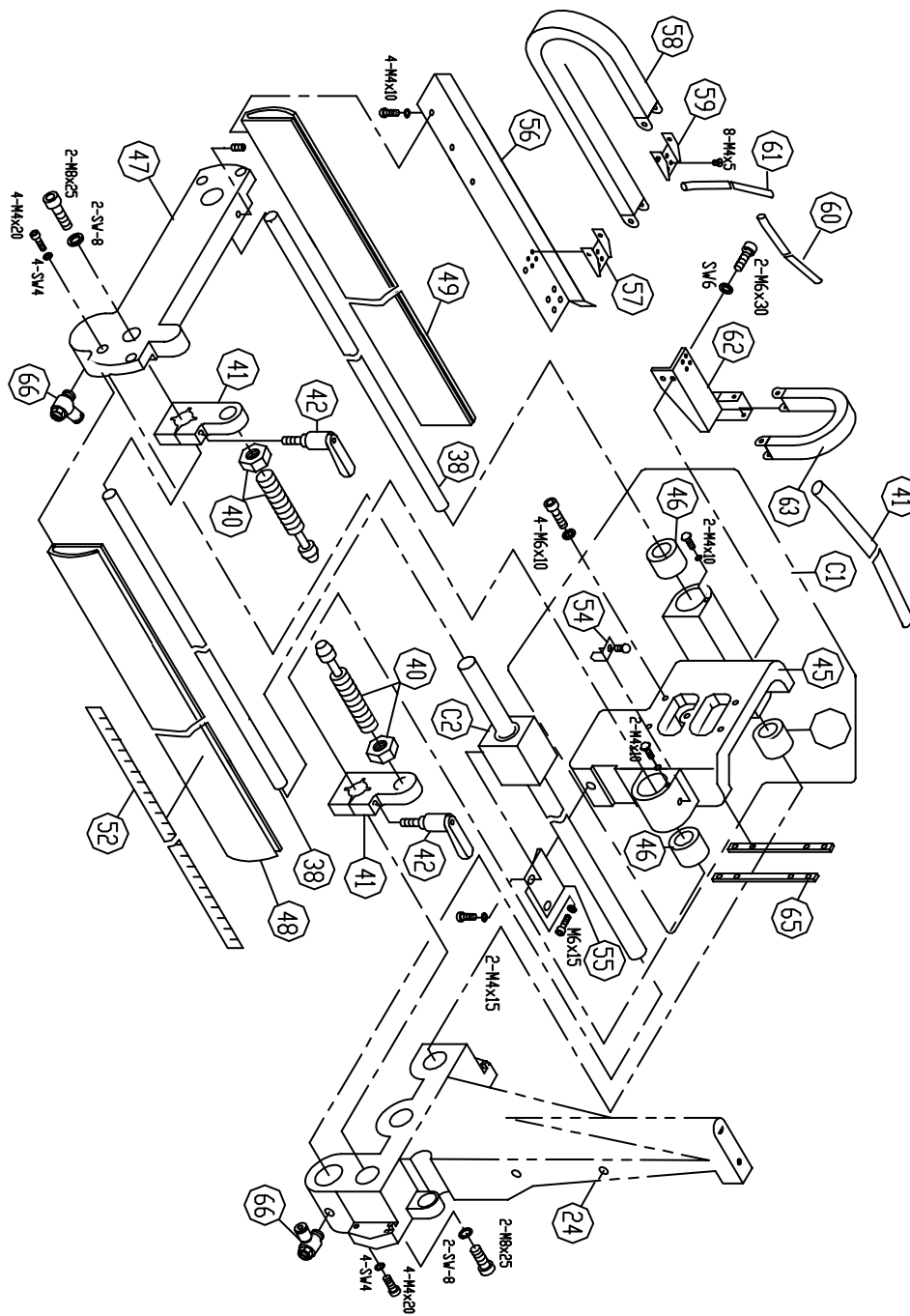

Strip Frame (base unit) - Models MXR-60 and MXR-150

Ref.	Part No.	Description	Quantity
24	C501R-C	Swing Arm	1
C1	C9500	Slide Unit Set	1
45	C5021	Slide Unit	1
46	LM16UU	Strip Slide Bearing	3
47	C5031	Strip Frame Front Plate	1
48	C0217	Side (A) Plate, MXR-60	1
48	C0227	Side (A) Plate, MXR-150	1
49	C0218	Side (B) Plate, MXR-60	1
49	C0228	Side (B) Plate, MXR-150	1
52	S0091	Strip Stroke Scale Label	1
38	C0075	Shaft, MXR-60	2
38	C0076	Shaft, MXR-150	2
40	SC1415-2	Strip Shock Absorber	2
41	C0261	Strip Shock Absorber Mounting Bracket	1
42	H6-40	Clamp Lever	2
C2	RC9001	Strip Cylinder Assembly, MXR-60	1
C2	RC002	Strip Cylinder Assembly, MXR-150	1
54	C0135	Strip Indicator	1
55	C5051	Strip Cylinder Bracket	1
56	KR1016	Cable Track Support, MXR-60	1
56	KR1017	Cable Track Support, MXR-60	1
62	KR5101	Cable Track Support, Vertical	1
58	CC1828	Strip Stroke Cable Track, MXR-60	13
58	CC1828	Strip Stroke Cable Track, MXR-150	15
57	CC1828-01	Strip Cable Support Bracket A	1
59	CC1828-02	Strip Cable Support Bracket B	1
41	TUVN30B	Hose Protect Tube, 800mm	1
60	TUVN15B	Hose Protect Tube, 650mm	1
61	TUVN15B	Hose Protect Tube, 800mm	1
63	KR-R202B1	Vertical Cable Track Body, MXR-60	28
63	KR-R202CC1	Vertical Cable Track Cover, MXR-60	28
63	KR-R202B1	Vertical Cable Track Body, MXR-150	32
63	KR-R202CC1	Vertical Cable Track Cover, MXR-150	32
65	C5131	Slide Unit Holder	2
66	70100610	Speed Controller	2

Strip Frame (strip remote) - Models MXR-60 and MXR-150

Ref.	Part No.	Description	Quantity
24	C501R-C	Swing Arm	1
C1	C9500	Slide Unit Set	1
45	C5021	Slide Unit	1
46	LM16UU	Strip Slide Bearing	3
47	C5031	Strip Frame Front Plate	1
48	C0217	Side (A) Plate, MXR-60	1
48	C0227	Side (A) Plate, MXR-150	1
49	C0218	Side (B) Plate, MXR-60	1
49	C0228	Side (B) Plate, MXR-150	1
52	S0091	Strip Stroke Scale Label	1
38	C0075	Shaft, MXR-60	2
38	C0076	Shaft, MXR-150	2
53	C5101	Strip Ball Screw, MXR-60	1
53	C5111	Strip Ball Screw, MXR-150	1
C2	RC9001	Strip Cylinder Assembly, MXR-60	1
C2	RC002	Strip Cylinder Assembly, MXR-150	1
54	C0135	Strip Indicator	1
54-1	C0131	Strip Indicator (Forward)	1
55	C5051	Strip Cylinder Bracket	1
56	KR1016	Cable Track Support, MXR-60	1
56	KR1017	Cable Track Support, MXR-60	1
62	KR5101	Cable Track Support, Vertical	13
58	CC1828	Strip Stroke Cable Track, MXR-60	15
58	CC1828	Strip Stroke Cable Track, MXR-150	1
57	CC1828-01	Strip Cable Support Bracket A	1
59	CC1828-02	Strip Cable Support Bracket B	1
41	TUVN30B	Hose Protect Tube, 800mm	1
60	TUVN15B	Hose Protect Tube, 650mm	1
61	TUVN15B	Hose Protect Tube, 800mm	1
63	KR-R202B1	Vertical Cable Track Body, MXR-60	20
63	KR-R202CC1	Vertical Cable Track Cover, MXR-60	20
63	KR-R202B1	Vertical Cable Track Body, MXR-150	23
63	KR-R202CC1	Vertical Cable Track Cover, MXR-150	23
51	C5121	Over Run Stopper	2
65	C5131	Slide Unit Holder	2
M1	RMK002	Strip Forward Motor (2) Assembly	1
M2	RMK003	Strip Forward Motor (3) Assembly	1
66	70100610	Speed Controller	2

PARTS/LISTS

MODELS MXR-60 AND MXR-150

Strip Remote Motor

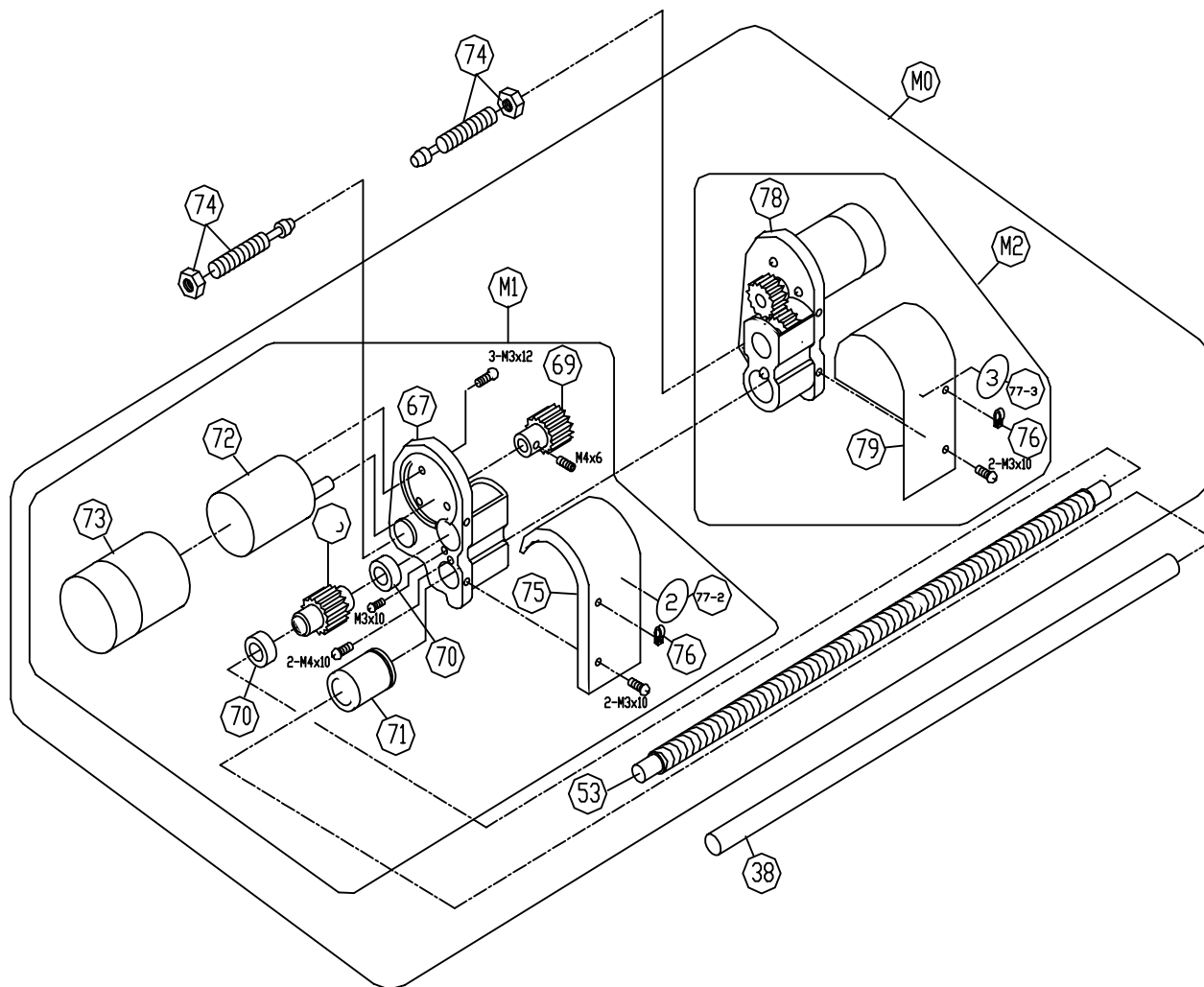

Strip Remote Motor - Models MXR-60 and MXR-150

Ref.	Part No.	Description	Quantity
38	C0071	Shaft, 16mm dia, L=385, MXR-60	2
38	C0072	Shaft, 16mm dia, L=505, MXR-150	2
53	C5101	Strip Ball Screw, MXR-60	1
53	C5111	Strip Ball Screw, MXR-150	1
67	RM0501	Motor Base (Forward)	1
68	RM0521	Gear (A)	2
69	RM0531	Gear (B)	2
70	6803Z	Gear Bearing	2
71	LM16UU	Strip Slide Bearing	2
72	HN-GH2421Y	Motor	2
73	RM0541	Motor Cover	2
74	SC1425-2	Shock Absorber	2
75	RM0541	Motor Base (Forward) Cover	1
76	NK-2N	Nylon Clamp	2
77-2	RM0612	Label (2)	1
77-3	RM0613	Label (3)	1
78	RM0511	Motor Base (Rear) Base	1
79	RM0561	Motor Base (Rear) Cover	1
M1	RMK002	Strip Forward Motor (2) Assembly	1
M2	RMK003	Strip Forward Motor (3) Assembly	1
M0	RMK000	Strip Motor Assembly Kit	1

PARTS/LISTS

MODELS MXR-60 AND MXR-150

Strip Cylinder

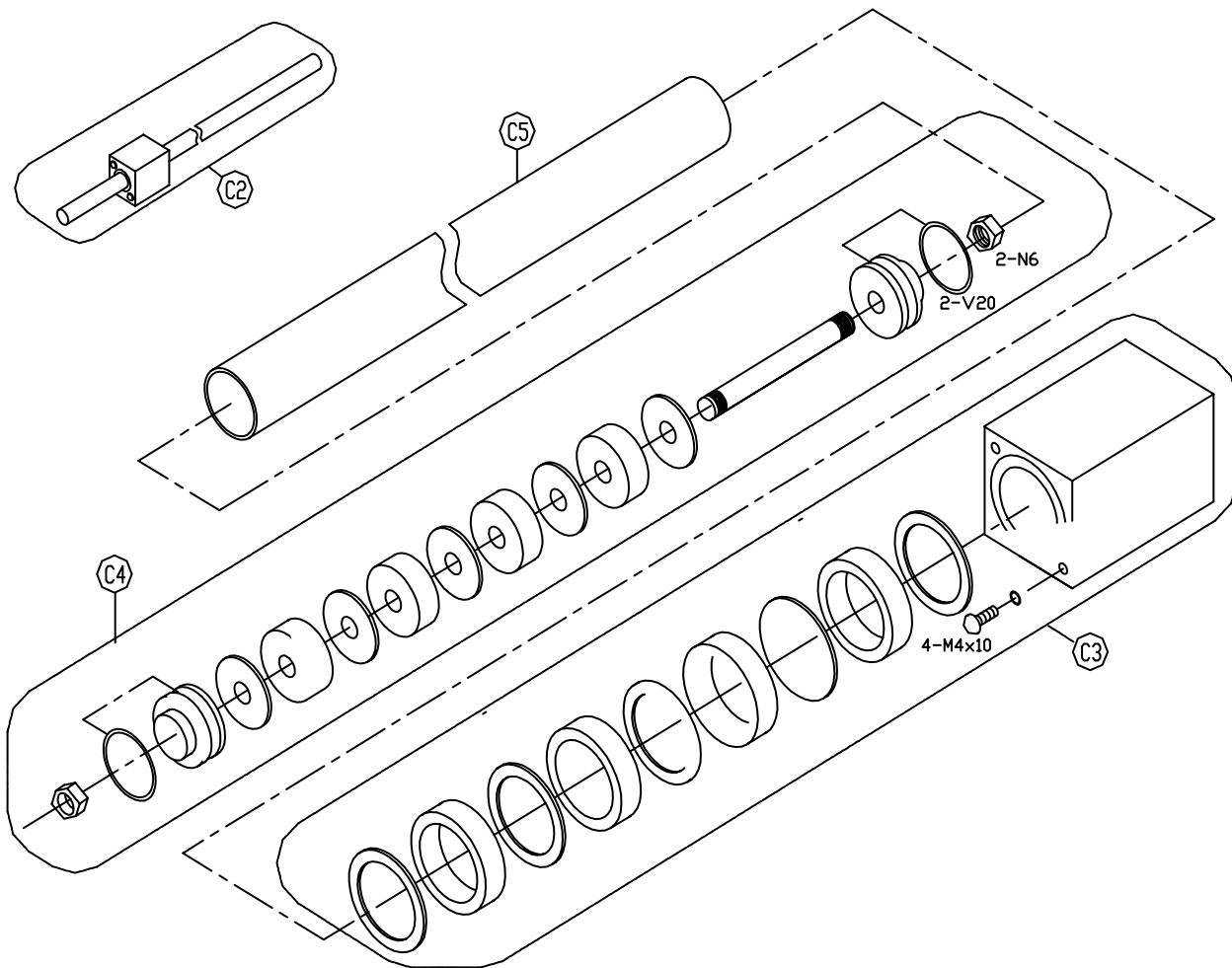

Strip Cylinder - Models MXR-60 and MXR-150

Ref.	Part No.	Description	Quantity
C2	RC9001	Strip Cylinder Assembly, MXR-60	1
C2	RC9002	Strip Cylinder Assembly, MXR-150	1
C3	RC0101	Strip Cylinder Holder Assembly	1
C4	RC0111	Strip Cylinder Piston Assembly, MXR-60	1
C4	RC0112	Strip Cylinder Piston Assembly, MXR-150	1
C5	RC0121	Strip Cylinder Pipe, MXR-60	1
C5	RC0122	Strip Cylinder Pipe, MXR-60	1

PARTS/LISTS

MODELS MXR-60 AND MXR-150

Main Arm Assembly

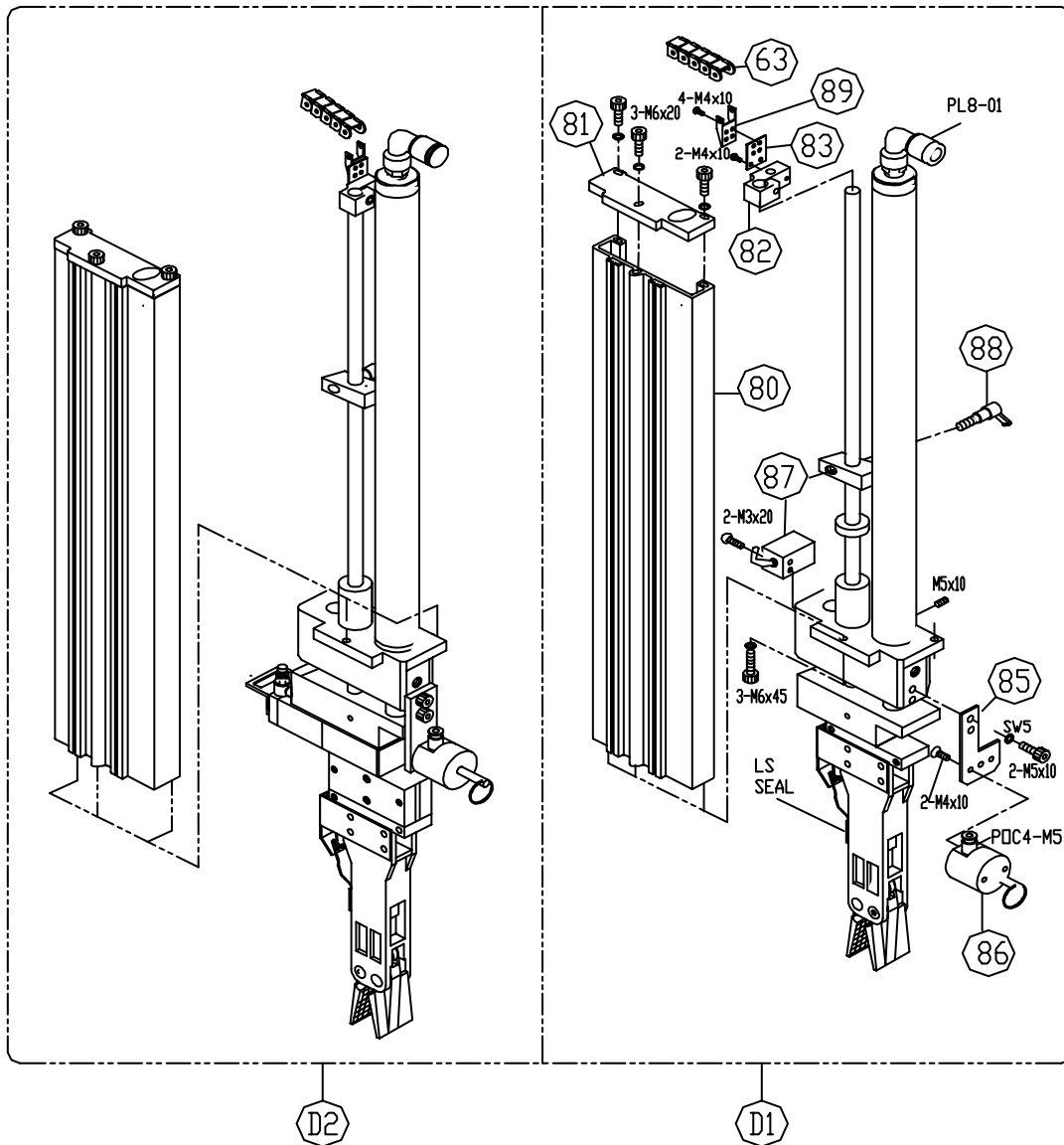

Main Arm Assembly - Models MXR-60 and MXR-150

Ref.	Part No.	Description	Quantity
D1	D9521	Main Arm Assembly, MXR-60F	1
D1	D9522	Main Arm Assembly, MXR-150F	1
D2	D9511	Main Arm Assembly, MXR-60	1
D2	D9512	Main Arm Assembly, MXR-150	1
80	D5021	Main Arm Cover, MXR-60	1
80	D5022	Main Arm Cover, MXR-150	1
81	D5011	Main Arm Cover Top	1
82	KR5011	Vertical Cable Track Bracket	1
83	D5111	Stopper Plate Bracket	1
85	D5101	Main Lock Cylinder Bracket	1
86	DA14-07	Main Lock Cylinder	1
87	JD1705E1	Proximity Switch	1
88	H6-20	Clamp Lever	1
89	KR5021	Bracket	1
63	KR0R202B1	Vertical Cable Track Body, MXR-60	28
63	KR0R202CC1	Vertical Cable Track Cover, MXR-150	28
63	KR0R202B1	Vertical Cable Track Body, MXR-60	32
63	KR0R202CC1	Vertical Cable Track Cover, MXR-150	32
	PL8-01	Fitting, Pisco	1
	PLJ8	Fitting, Pisco	1
	PL6-01	Fitting, Pisco	1
	POC4-M5	Fitting, Pisco	1

PARTS/LISTS

MODELS MXR-60 AND MXR-150

Main Arm Assembly (vertical remote)

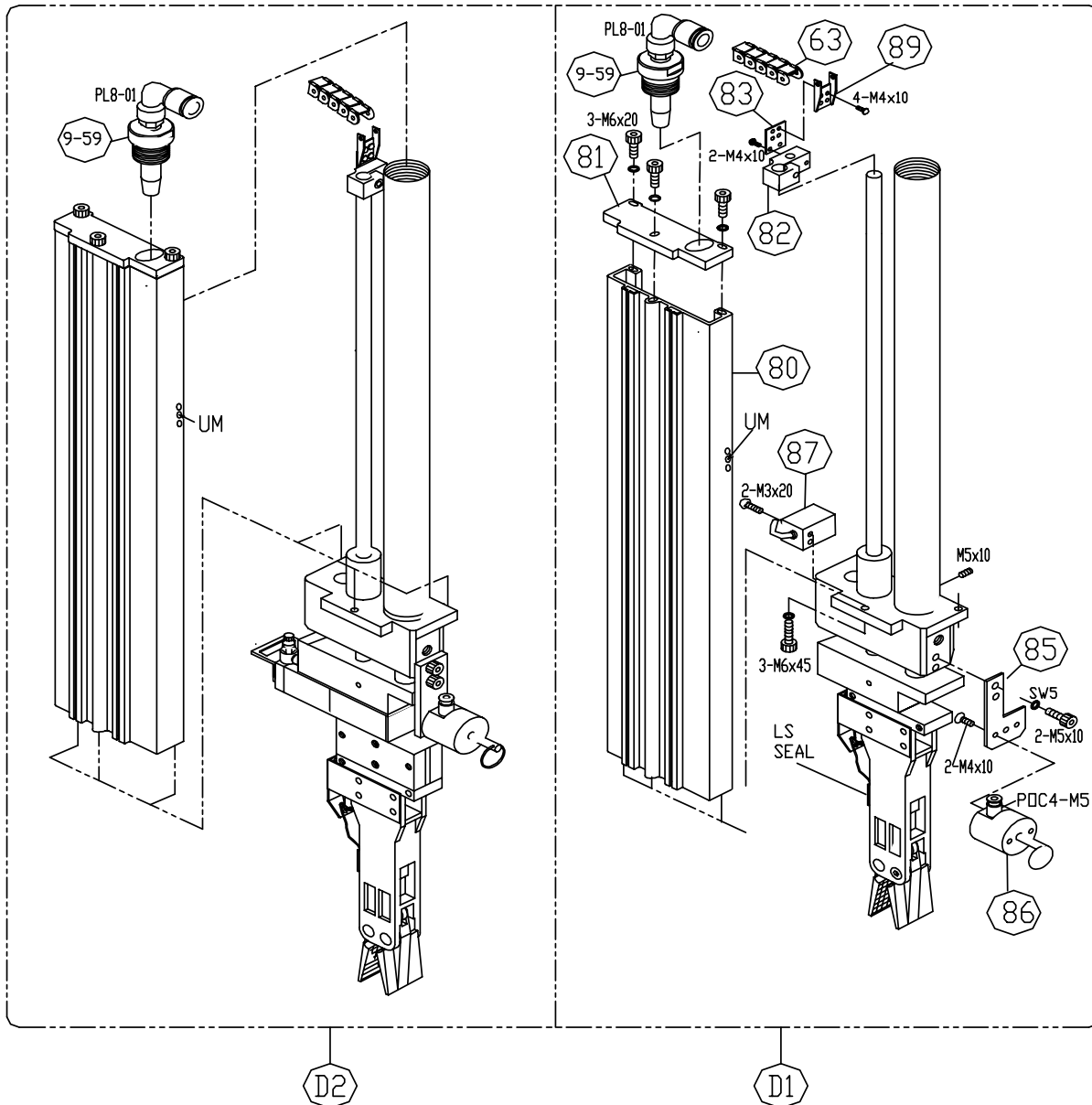

**Main Arm Assembly (vertical remote) -
Models MXR-60 and MXR-150**

Ref.	Part No.	Description	Quantity
D1	D9521	Main Arm Assembly, MXR-60F	1
D1	D9522	Main Arm Assembly, MXR-150F	1
D2	D9511	Main Arm Assembly, MXR-60	1
D2	D9512	Main Arm Assembly, MXR-150	1
80	D5021	Main Arm Cover, MXR-60	1
80	D5022	Main Arm Cover, MXR-150	1
81	D5011	Main Arm Cover Top	1
82	KR5011	Vertical Cable Track Bracket	1
83	D5111	Stopper Plate Bracket	1
85	D5101	Main Lock Cylinder Bracket	1
86	DA14-07	Main Lock Cylinder	1
87	JD1705E1	Proximity Switch	1
88	H6-20	Clamp Lever	1
89	KR5021	Bracket	1
63	KR0R202B1	Vertical Cable Track Body, MXR-60	28
63	KR0R202CC1	Vertical Cable Track Cover, MXR-150	28
63	KR0R202B1	Vertical Cable Track Body, MXR-60	32
63	KR0R202CC1	Vertical Cable Track Cover, MXR-150	32
9-59	A0051	Main Cylinder End Cap	1
	PL8-01	Fitting, Pisco	1
	PLJ8	Fitting, Pisco	1
	PL6-01	Fitting, Pisco	1
	POC4-M5	Fitting, Pisco	1

PARTS/LISTS

MODELS MXR-60 AND MXR-150

Vertical Remote Assembly

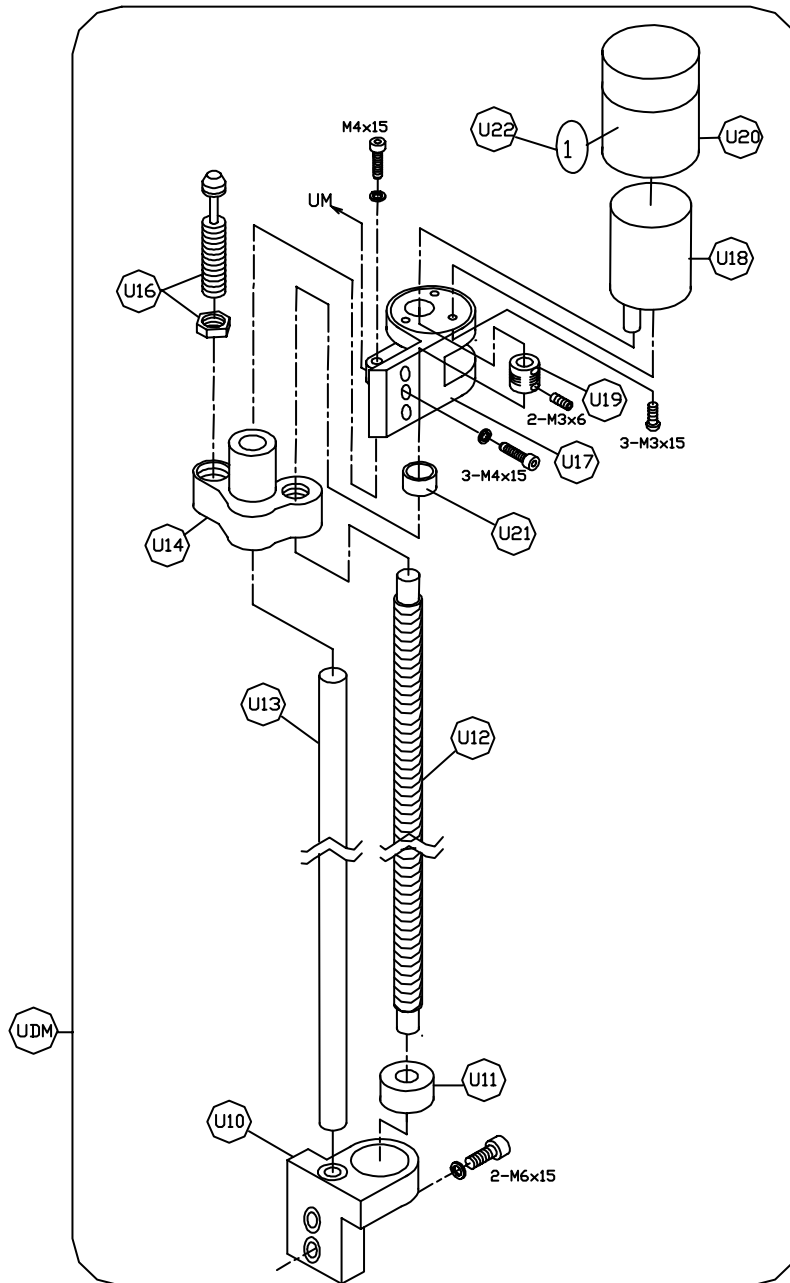

Vertical Remote Assembly - Models MXR-60 and MXR-150

Ref.	Part No.	Description	Quantity
U10	RU0011	Vertical Remote Lower Holder	1
U11	608RD1	Bushing	1
U12	RU0021	Vertical Remote Ball Screw	1
U13	RU0031	Vertical Remote Guide Rod	1
U14	RU0041	Vertical Stroke Adjustment Base	1
U16	SC2050	Shock Absorber	1
U17	RU0061	Vertical Remote Motor Holder	1
U18	HN-GH2421Y	Motor	1
U19	JT001	Motor Shaft Coupling	1
U20	RM0541	Motor Cover	1
U21	BU1012	Vertical Ball Screw Bushing	1
U22	RM0611	Label (1)	1
UDM	UDM000	Vertical Remote Kit, MXR60/150	1

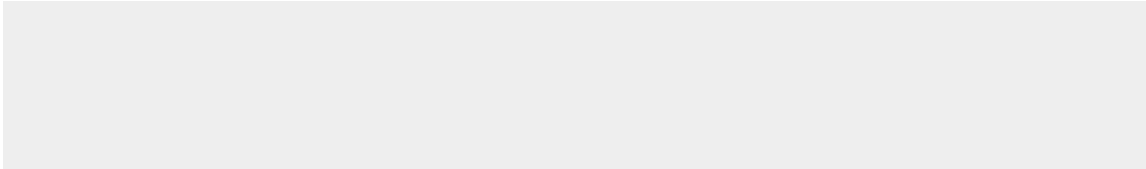

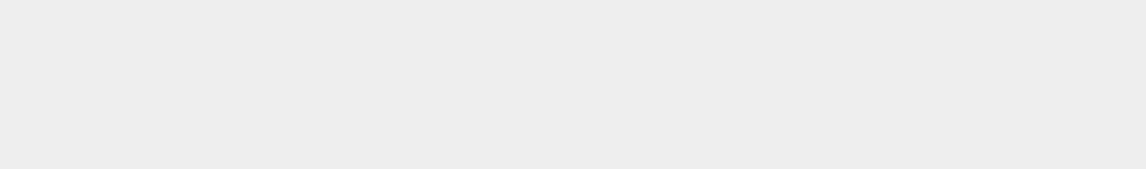

Main Cylinder Assembly - Models MXR-60 and MXR-150

Ref.	Part No.	Description	Quantity
D3	D9581	Main Cylinder Assembly, MXR-60	1
D3	D9582	Main Cylinder Assembly, MXR-150	1
59	A0051	Main Cylinder End Cap	1
D4	D9105	Rod and Piston Assembly, MXR-60	1
D4	D9115	Rod and Piston Assembly, MXR-150	1
61	D1151	Piston Nut	1
62	D0041	Main Cylinder Piston	1
63	D0051	Main Cylinder Piston Collar	2
64	D0067	Main Cylinder Rod, MXR-60	1
64	D0068	Main Cylinder Rod, MXR-150	2
65	D0081	Main Rod End Cap	1
66	D0805	Main Cylinder Pipe, MXR-60	1
66	D0806	Main Cylinder Pipe, MXR-150	1
	PGY25	Seal	2
	SWB-25	Wear Ring	1
	P-10	Seal	1
	P-22A	Seal	1

PARTS/LISTS

MODELS MXR-60 AND MXR-150

Main Arm

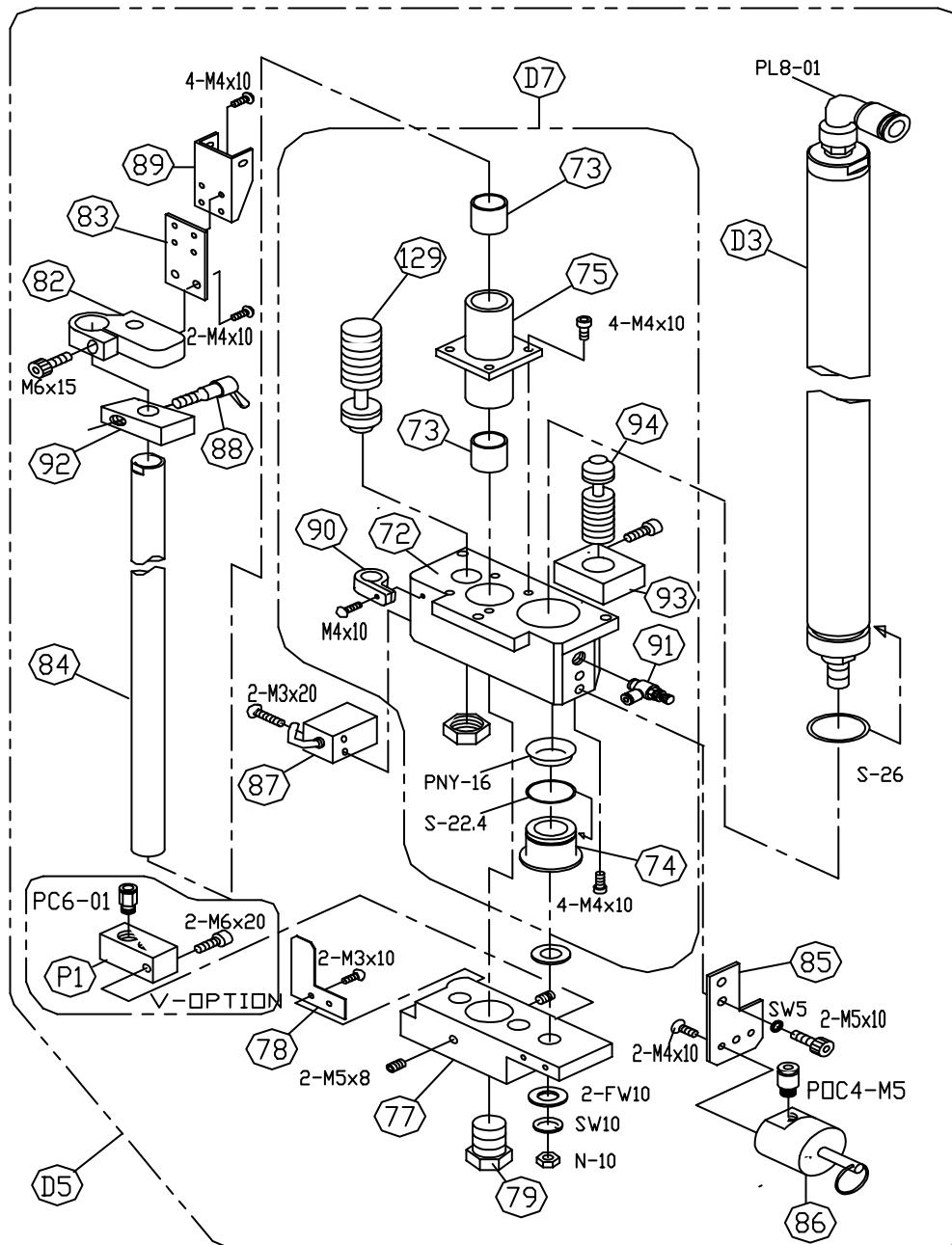

Main Arm - Models MXR-60 and MXR-150

Ref.	Part No.	Description	Quantity
D5	D9531	Main Arm w/o Grip Assembly, MXR-60	1
D5	D9532	Main Arm w/o Grip Assembly, MXR-150	1
D7	D9661	Terminal Block Assembly	1
72	D5061	Main Cylinder Terminal Bracket	1
74	D0231	Main Cylinder Main Rod Metal	1
75	D1071	Main Cylinder Side Metal	1
73	BU1820	Bush	2
129	SC2030	Shock Absorber	1
87	JD1705E1	Proximity Switch	1
85	D5101	Main Lock Cylinder Bracket	1
86	DA14-07	Main Lock Cylinder	1
77	D1111	Main Cylinder End Bracket	1
78	D1091	Actuator, LS-3 Proximity	1
79	D0271	Rod End Cap	1
82	D1181	Tube and Wiring Bracket	1
89	KR5021	Vertical Cable Track Bracket	1
83	D5191	Cable Track Bracket	1
90	NK-8N	Vinyl Code Clip	1
91	70100610	Speed Controller	1
84	D0126	Side Pipe, MXR-60	1
84	D0127	Side Pipe, MXR-150	1
P1	D1171	Vacuum Option Bracket	1
D3	D9581	Main Cylinder Assembly, MXR-60	1
D3	D9582	Main Cylinder Assembly, MXR-150	1
88	H6-20	Clamp Lever	1
92	D1145	Main Stroke Stopper	1
93	D5201	Shock Absorber Holder	1
94	SC2050	Shock Absorber	1
	S-22.4	O-Ring	1
	PNY-16	Packing	1
	S-26	O-Ring	1

PARTS/LISTS

MODELS MXR-60 AND MXR-150

Main Arm (vertical remote)

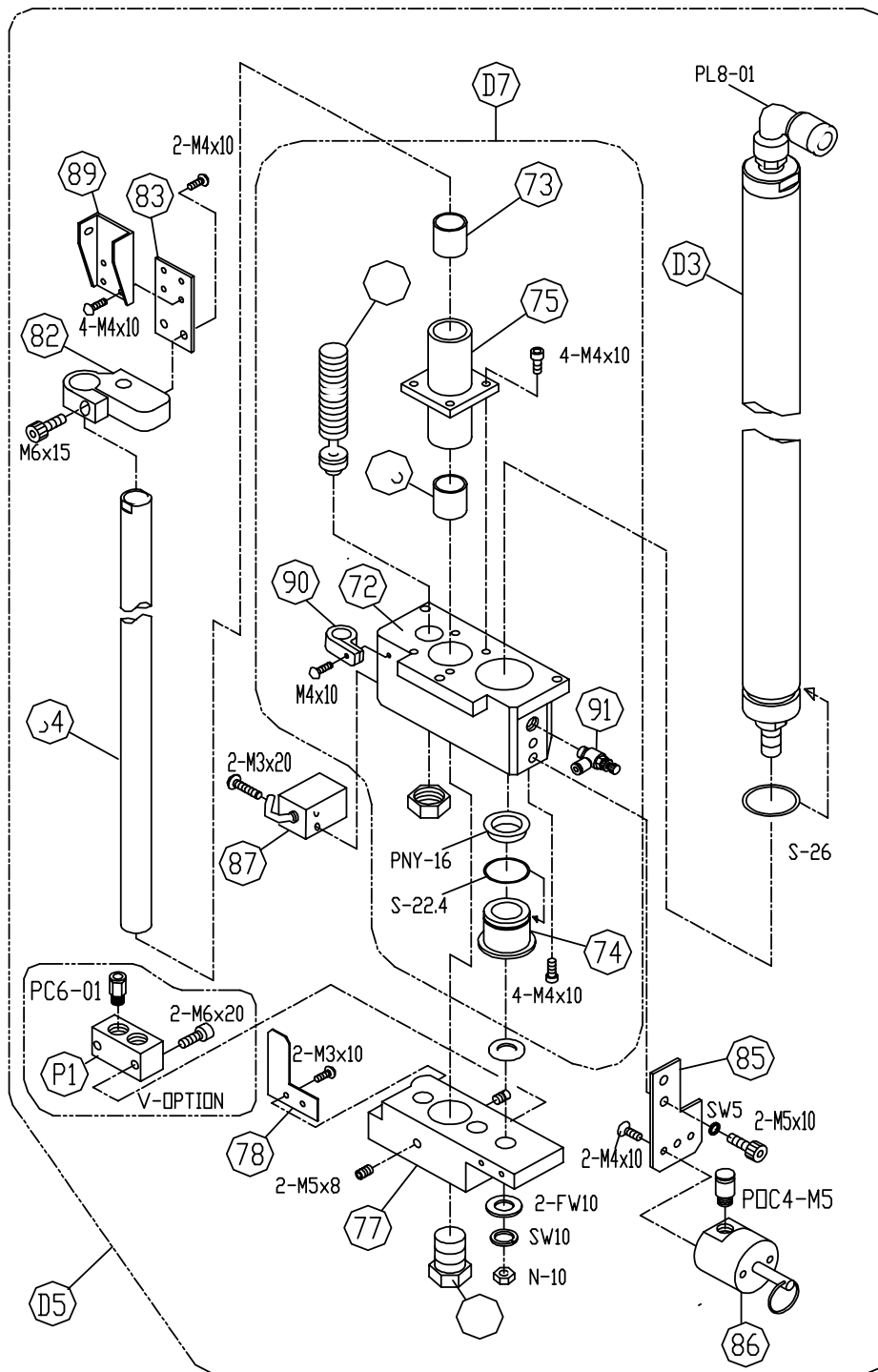

Main Arm (vertical remote) - Models MXR-60 and MXR-150

Ref.	Part No.	Description	Quantity
D5	D9531	Main Arm w/o Grip Assembly, MXR-60	1
D5	D9532	Main Arm w/o Grip Assembly, MXR-150	1
D7	D9661	Terminal Block Assembly	1
72	D5061	Main Cylinder Terminal Bracket	1
74	D0231	Main Cylinder Main Rod Metal	1
75	D1071	Main Cylinder Side Metal	1
73	BU1820	Bush	2
129	SC2030	Shock Absorber	1
87	JD1705E1	Proximity Switch	1
85	D5101	Main Lock Cylinder Bracket	1
86	DA14-07	Main Lock Cylinder	1
77	D1111	Main Cylinder End Bracket	1
78	D1091	Actuator, LS-3 Proximity	1
79	D0271	Rod End Cap	1
82	D1181	Tube and Wiring Bracket	1
89	KR5021	Vertical Cable Track Bracket	1
83	D5191	Cable Track Bracket	1
90	NK-8N	Vinyl Code Clip	1
91	70100610	Speed Controller	1
84	D0126	Side Pipe, MXR-60	1
84	D0127	Side Pipe, MXR-150	1
P1	D1171	Vacuum Option Bracket	1
D3	D9581	Main Cylinder Assembly, MXR-60	1
D3	D9582	Main Cylinder Assembly, MXR-150	1
	S-22.4	O-Ring	1
	PNY-16	Packing	1
	S-26	O-Ring	1

PARTS/LISTS

MODELS MXR-60 AND MXR-150

Wrist Rotation

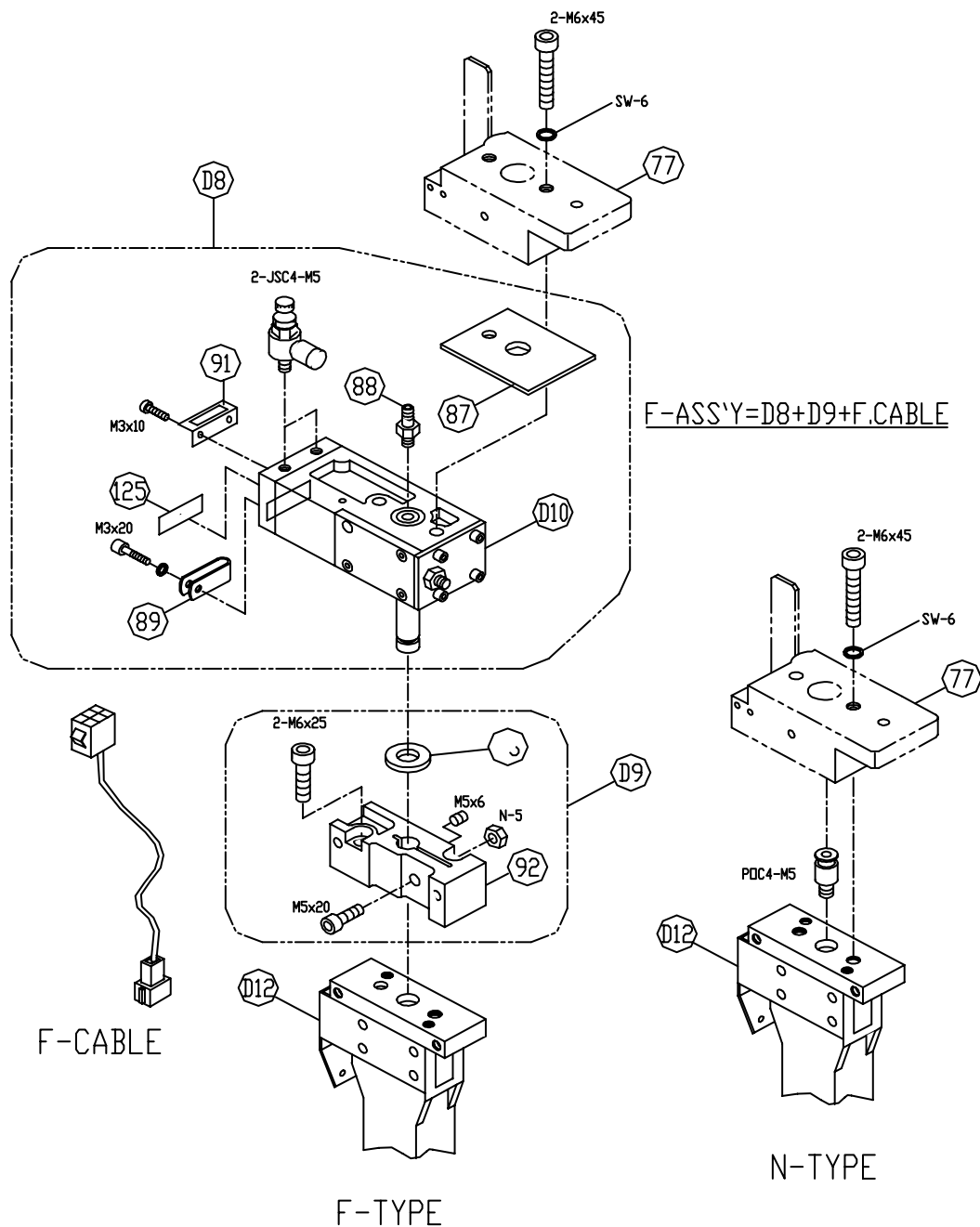

Wrist Rotation - Models MXR-60 and MXR-150

Ref.	Part No.	Description	Quantity
77	D1111	Main Cylinder End Bracket	1
D8	D9140	Wrist Rotation Unit Assembly	1
87	D0331	Wrist Unit Attach Plate	1
88	BF-5	TAC Fitting	1
89	NK-2N	Nylon Clamp	1
91	FG0011	Connector Bracket	1
D10	D9130	Wrist Cylinder Assembly	1
D9	D9151	EOAT Mount Set	1
92	D0931	EOAT Mounting Block, MXR-F type	1
93	D0491	Wrist Rotate Thrust Washer	1
D12	D9191	Gripper with LS-4 Assembly	1
	FG0051	Wrist Rotate Cable/Connector	1
	JSC4-M5	Speed Controller	2
	POC4-M5	Pisco Fitting	1
	H7755R-03	Female Connector	1
	7755TR	Female Connector Pin	3
	H7755P-03	Male Connector	1
	7755PR	Male Connector Pin	3

PARTS/LISTS
MODELS MXR-60 AND MXR-150

Gripper Assembly

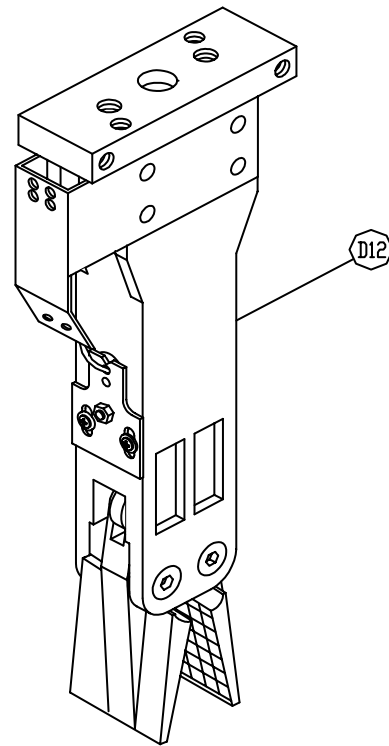

Gripper Assembly - Models MXR-60 and MXR-150

Ref.	Part No.	Description	Quantity
D12	D9191	Gripper Assembly with LS-4	1

PARTS/LISTS

MODELS MXR-60 AND MXR-150

Gripper

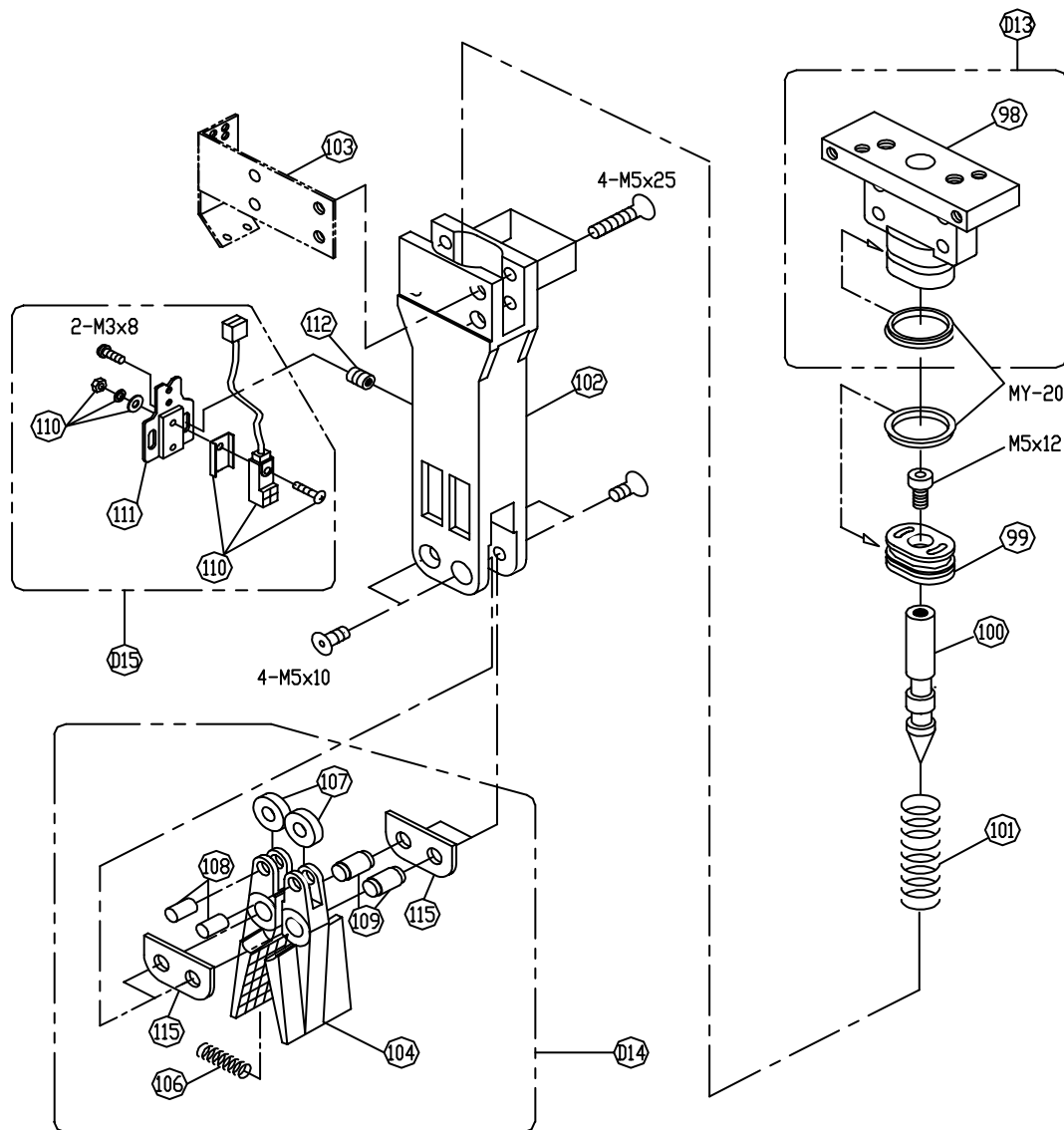

Gripper - Models MXR-60 and MXR-150

Ref.	Part No.	Description	Quantity
D13	D9230	Finger Cap Assembly	1
98	D0841	Gripper Mounting Block	1
99	D05911	Gripper Seal	1
100	D083	Gripper Wedge, Vertical	1
101	D0621	Piston Return Spring	1
102	D0881	Gripper Body, Vertical	1
103	D0661	LS-4 Cable Cover Bracket	1
D14	D9220	Fingers Set	1
104	D0671	Gripper Finger	2
106	D1161	Gripper Finger Open Spring	1
107	D0681	Gripper Finger Roller	2
108	D0891	Gripper Finger Roller Pin	2
109	D0702	Gripper Collar with Flange	2
115	GR0011	Finger Support Plate	2
D15	D9211	LS-4 Proximity and Mount Set	1
110	GXL-8F	Proximity Switch	1
111	D0902	Proximity Switch Mounting Plate	1
112	8130030	LS-4 Mounting Metal Insert	2
	MY20	Seal	2

PARTS/LISTS

MODELS MXR-60 AND MXR-150

Vacuum Venturi Kit

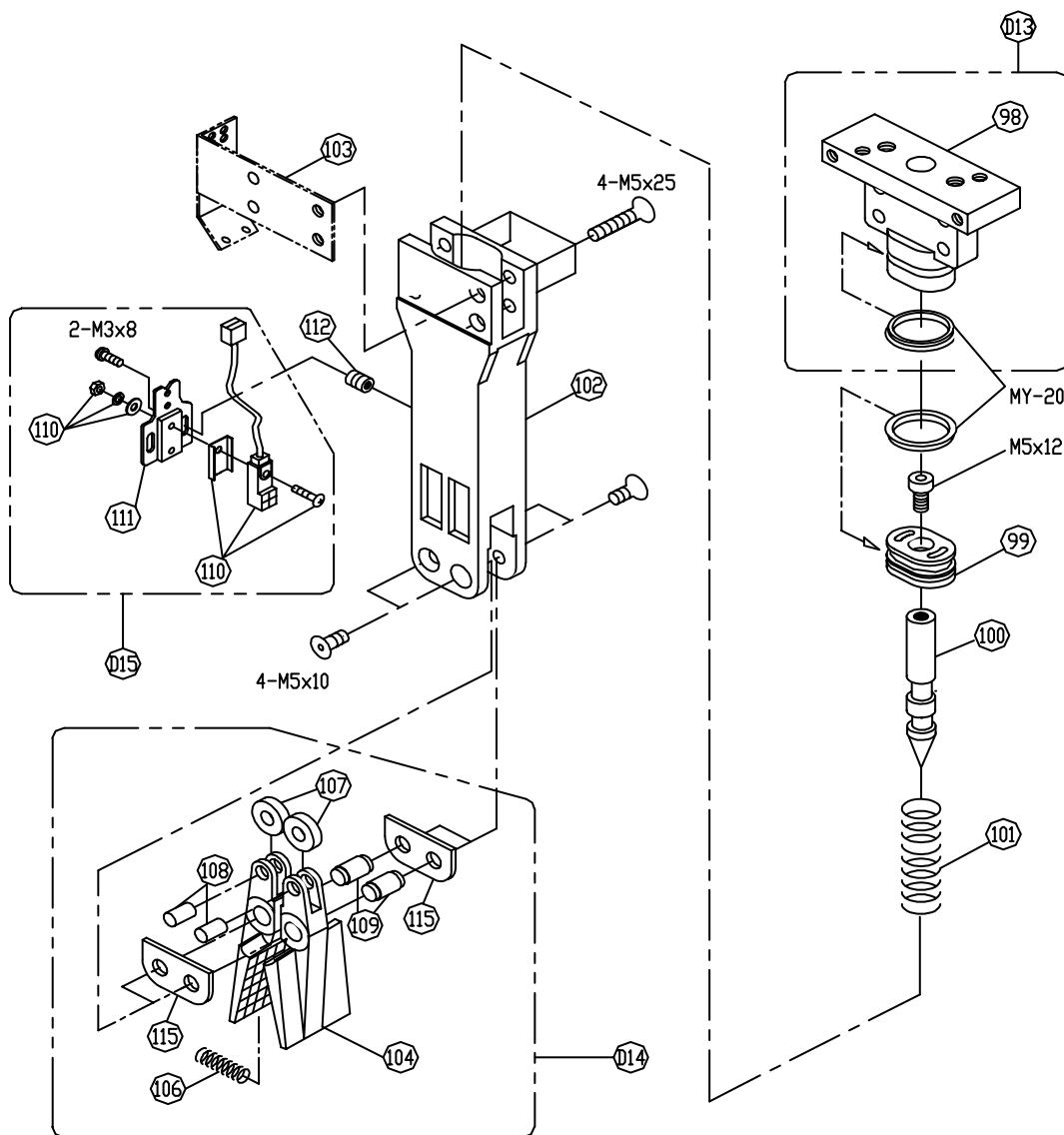

Vacuum Venturi Kit - Models MXR-60 and MXR-150

Ref.	Part No.	Description	Quantity
602	181-4E1	Koganei Valve	1
604	AV10H	Air Ejector	1
607	MF1011	Manifold	1
608	VG-01	Pressure Gauge	1
609	SK-401	Air Connector	1
82	P0042	Optional Bracket (A + B)	1
P1	P0051	Optional Air Bracket	1
	PL8-02	Pisco Fitting	1
	PL6-01	Pisco Fitting	1
	PL4-01	Pisco Fitting	4
	PC6-01	Pisco Fitting	3
	PD4-02	Pisco Fitting	1
	PAX4-01	Pisco Fitting	1
	SLB-01	Silencer	2
	SR-01	Silencer	1
	PRG1/8	Screw	2
	GEN-00032MX	Vacuum Kit	1

PARTS/LISTS

MODELS MXR-60 AND MXR-150

Wrist Cylinder

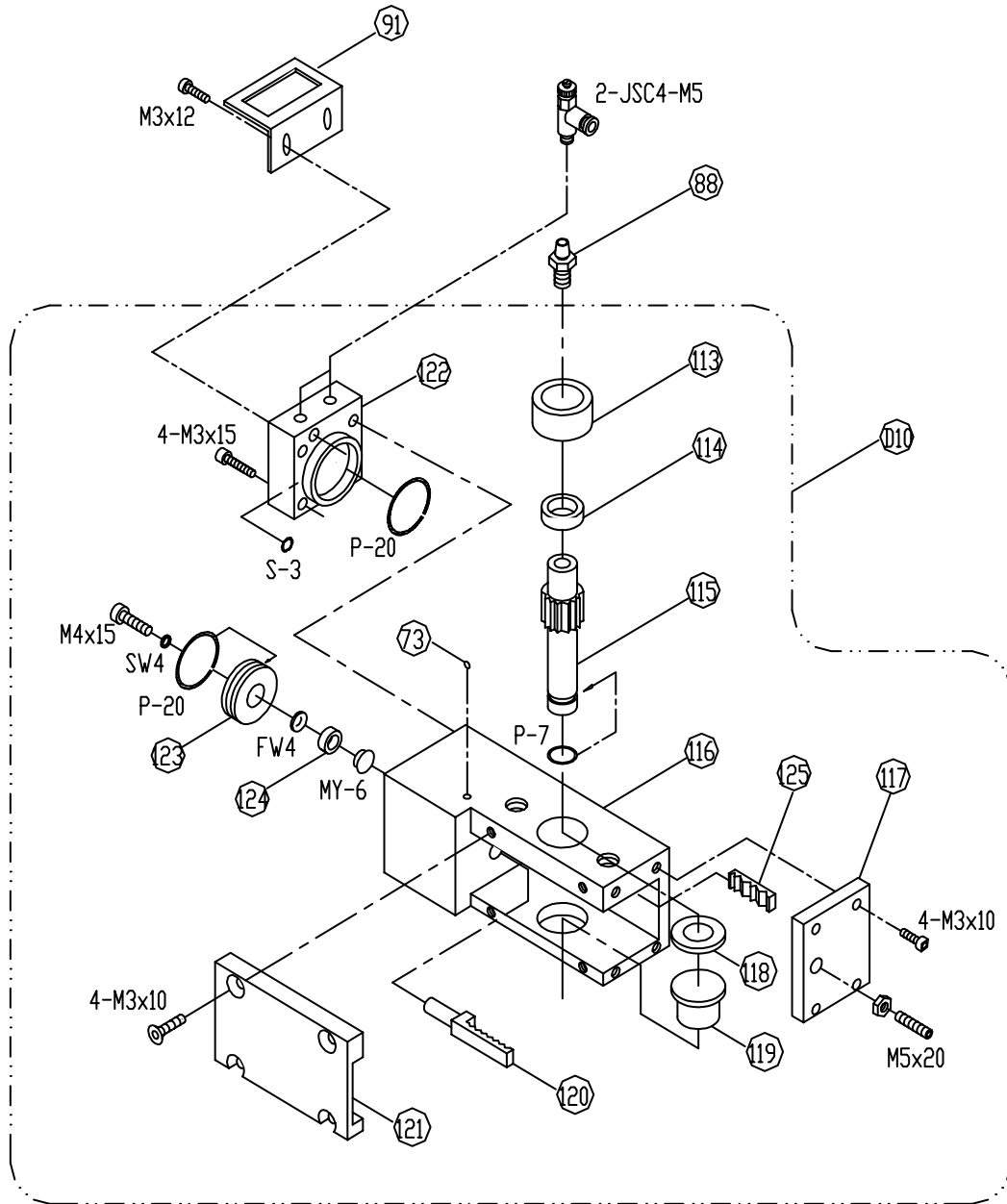

Wrist Cylinder - Models MXR-60 and MXR-150

Ref.	Part No.	Description	Quantity
D10	D9130	Wrist Cylinder Assembly	1
73	D0213	3/8" Steel Ball	1
113	D0381	Wrist Cylinder Bush (A)	1
114	D0391	Wrist Cylinder Spacer (A)	1
115	D0371	Wrist Cylinder Pinion Shaft	1
116	D0921	Wrist Cylinder Housing	1
117	D0401	Wrist Cylinder Cover (A)	1
118	D0411	Wrist Cylinder Spacer (B)	1
119	D04221	Wrist Cylinder Bush (B)	1
120	D0431	Wrist Cylinder Rack	1
121	D0951	Wrist Cylinder Cover	1
122	D0341	Wrist Cylinder Cap	1
123	D0451	Wrist Cylinder Piston	1
124	D0441	Wrist Cylinder Bush C	1
88	BF-5	TAC Fitting	1
91	FG001	Connector Bracket	1
125	D0432	Wrist Cylinder Rack (B)	1
	S-3	Seal	1
	P-20	Seal	2
	P-7	Seal	1
	MY-6	Seal	1
	81100201	Wrist Rotation Kit	1

PARTS/LISTS

MODELS MXR-60 AND MXR-150

CD-EM1 Controller

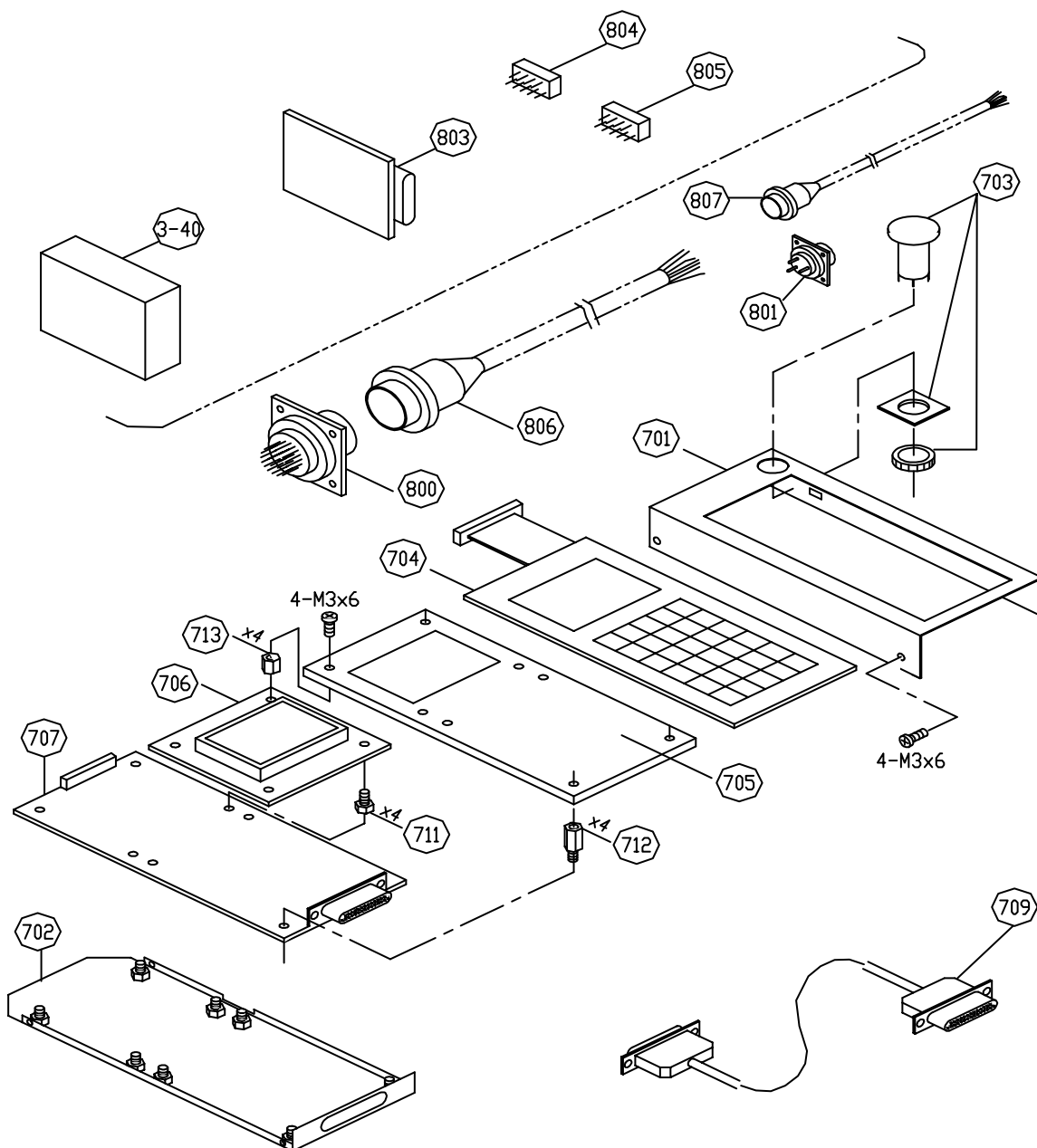

CD-EM1 Controller - Models MXR-60 and MXR-150

Ref.	Part No.	Description	Quantity
701	HC5001	Pendant Upper Cover	1
702	HC5011	Pendant Lower Cover	1
703	AB6-V	Emergency stop Switch	1
704	KYB-EM01	CD-EM1 Keyboard Panel	1
705	HC5021	Keyboard Support Plate	1
706	LCD182X64	LCD Display with Board	1
707	M20-1	Pendant Cont. Electrical PCB	1
709	KB37-4	Cable/Connector to Robot	1
711	HC1041	Screw B	4
712	HC1051	Spacer C	4
713	HC1061	Spacer D	4
36	B1011R-C	Valve Mounting Housing	1
37	B1025R-C	Valve Housing Cover	1
40	ID60B	Power Supply Unit	1
44	BZ-35C1	Buzzer	1
42	MR-R19	OBO On/Off Switch	1
800	L-20M	Interface Connector 20P	1
	KB2820RM	20P Connector Dummy Plug	1
801	L-3M	Power Cable Connector 3P	1
803	M20-03	I/O Relay Board	1
804	G6B-1174P	Relay A	2
805	RY24W-K	Relay B	8
806	KB26-6	Interface Cable to Press (6m)	1
807	KB3-6	Power Cable to Press (6m)	1
806	KB26-8	Interface Cable to Press (8m)	1
807	KB3-8	Power Cable to Press (8m)	1
	FUSE05	Fuse (500mA)	1
	CD-EM1	CD-EM1 Pendant Controller	1
