

USERGUIDE

# KBCC-R



**WARNING - Reliance on this Manual Could Result in Severe Bodily Injury or Death!**

This manual is out-of-date and is provided only for its technical information, data and capacities. Portions of this manual detailing procedures or precautions in the operation, inspection, maintenance and repair of the product forming the subject matter of this manual may be inadequate, inaccurate, and/or incomplete and cannot be used, followed, or relied upon. Contact Conair at [info@conairgroup.com](mailto:info@conairgroup.com) or 1-800-654-6661 for more current information, warnings, and materials about more recent product manuals containing warnings, information, precautions, and procedures that may be more adequate than those contained in this out-of-date manual.

# KBCC™ Chassis Mount Solid State DC Motor Speed Controls



*Improved*—Contains  
KBMM\* Speed Control  
and APRM\*-2C for  
Faster Switching

## Installation and Operating Instructions

**KBCC™**  
Unidirectional

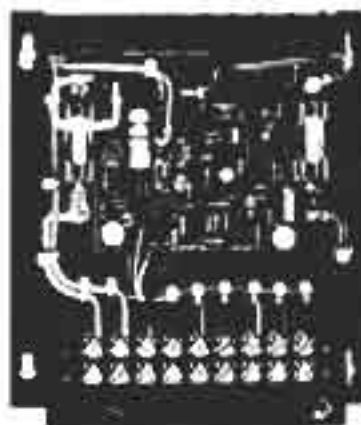

**KBCC-R Suffix**  
Rapid Cycling  
Instant Reversing  
Solid State Dynamic Braking

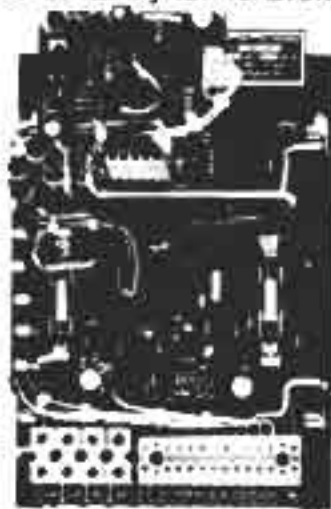

**5K Remote  
Potentiometer  
(Included)**



**Knob and Dial Plate  
(Accessory Items  
Not Included)**



- Ratings up to 1½ HP-120V & 3HP-240V
- Multiple Horsepower Capability with Plug-In Horsepower Resistor®
- Voltage Following
- R-Suffix Models contain the KB APRM® which provides Instant Anti-Plug Reversing and Solid State Dynamic Braking.
- AC Line and Armature Fusing
- Short Circuit Proof
- Direct Fed® Current Limit Prevents Motors from Demagnetizing

© 1990 KB ELECTRONICS, INC.

See SAFETY WARNING on page 4

# PENTA **KB** POWER™

A COMPLETE LINE OF SCR DRIVES

\*Patented

# TABLE OF CONTENTS

Section	Page
Simplified Instructions .....	3
Warranty .....	28
Electrical Ratings .....	4
Features and Functions .....	5
Introduction .....	6
<b>I General Information .....</b>	<b>6</b>
A. Motor Type .....	6
B. Torque Requirements .....	6
C. Acceleration Start .....	6
D. Limitations in Use .....	6
E. Switching Applications .....	6
<b>II Installation Instructions .....</b>	<b>7</b>
A. Location and Mounting .....	7
B. Initial Setup and Wiring .....	7
C. Voltage Following .....	9
D. Fusing .....	9
<b>III Adjustments and Control Functions .....</b>	<b>11</b>
A. Acceleration Start (ACCEL) .....	11
B. Deceleration (DECEL) .....	11
C. Maximum Speed Adjustment (MAX) .....	11
D. Minimum Speed Adjustment (MIN) .....	11
E. Current Limit (CL)/Torque .....	11
F. IR Compensation (IR) .....	11
<b>IV Application Information .....</b>	<b>12</b>

Section	Page
<b>V Troubleshooting Guide .....</b>	<b>19</b>
<b>VI Wiring Diagrams, Schematics and Parts Lists</b>	
A. KBCC-"R" Suffix Models Internal Connection Diagram .....	20
B. Speed Control Module Schematic .....	21
C. APRM® Schematic .....	22
D. Speed Control Module Parts List .....	23
E. APRM® Parts List .....	25

## LIST OF ILLUSTRATIONS

Figure	Page
1. Features and Functions .....	5
2. Mechanical Specifications .....	7
3. Connection Diagram .....	8
4. ACCEL/DECEL Trimpot Adjustment .....	10
5. Internal Connection Diagram .....	20

## LIST OF TABLES

Table	Page
1. Nominal Trimpot Settings .....	3
2. Electrical Ratings .....	4
3. General Performance Specifications .....	4
4. Plug-in Horsepower Resistor® Chart .....	5
5. Minimum Supply Wire Size Requirements .....	8
6. Armature Fuse Chart .....	9

## IMPORTANT

Read these simplified instructions before operating control. (SEE WARNING ON PAGE 18.)

1. Be sure input AC line voltage corresponds to control voltage. (See electrical rating chart page 4.)
2. Install the correct Plug-in Horsepower Resistor® (supplied separately) according to input voltage and motor horsepower (see chart, page 5).
3. Recheck connections: AC line to L1 and L2; armature to A1 and A2 and Field (Shunt motors only) to F+ and F-. Connect ground via ground screw. (Note: If motor runs in improper direction, interchange armature leads.)
4. Connect S1 to S2 or S2 to S3 to activate control. LED brake light will be "on" if no connection is made.
5. AC Line Fuse and Armature Fuse are installed in this product. (See page 9, Table 6.) Use correct fuse.
6. Nominal trimpot settings are as follow (expressed in % of full CW rotation):

### TABLE 1: NOMINAL TRIMPOT SETTINGS—SPEED CONTROL MODULE

MIN (minimum speed):	15%	CL (current limit/torque):	65%	For detailed instructions see Sec. III
MAX (maximum speed):	65%	ACCEL (acceleration start):	20%	
IR (IR compensation):	25%	DECEL (deceleration):	20%	

FOR TECHNICAL ASSISTANCE CALL TOLL FREE ( OUTSIDE  
NY STATE ONLY ) 1-800-221-6570

#### PLUG-IN HORSEPOWER RESISTOR®

A Plug-in Horsepower Resistor® must be installed to match the control to the motor horsepower and voltage. See Table 4 for the correct value. Plug-in Horsepower Resistors® are stocked by your distributor (supplied separately).

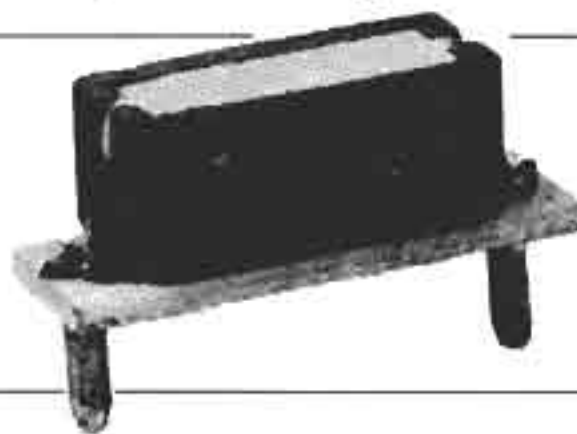

**TABLE 2. ELECTRICAL RATINGS**

MODEL NUMBER		AC VOLTS INPUT (50/60 Hz)	MAX. AC LOAD CURRENT (RMS AMPS)	MAX. DC LOAD CURRENT (AVG. AMPS)	MAX HP	AC LINE FUSE SIZE (AMPS)
UNIDIRECTIONAL	REVERSIBLE					
KBCC-125	KBCC-125R	120	24.0	16.0	1½	25
KBCC-225	KBCC-225R	240	24.0	16.0	3	25

**TABLE 3. GENERAL PERFORMANCE SPECIFICATIONS**

Speed range (ratio) .....	50:1	CL/torque range (% full load) .....	0-200
Load regulation—armature feedback (0-full load, 50:1 speed range) (% base speed) .....	1*	Accel time range (0-full speed) (secs.) .....	.2-10
Load regulation—tachometer feedback (0-full load, 50:1 speed range) (% set speed) .....	1*	Decel time range (full-0 speed) (secs.) .....	.2-10
Line voltage regulation—armature feedback (at full load, ±10% line variation (% base speed) .....	½*	Min. speed trimpot range (% full speed)	0-30*
Line voltage regulation—tachometer feedback (at full load, ±10% line variation (% set speed) .....	½*	Max. speed trimpot range (% full speed)	50-110*
Control linearity (% speed vs. dial rotation) .....	2	IR compensation trimpot range (at specified full load) (volts) .....	0-24
		Maximum allowable ambient temperature at full rating (°C/°F) .....	45/113
		Tachometer feedback input volts (per 1000 RPM) (VDC) .....	7/50
		Maximum number of starts/stops or reversals (operations/min.) .....	30**

\* Performance is for SCR rated PM motors only. Lower performance can be expected with other motor types. Factory setting is for 3% load regulation. To obtain superior regulation, see Sec. III F. Other factory trimpot settings are as follow: CL-150% FL, Accel-1 sec., Decel-1 sec., MIN-(0)-speed, MAX-full speed & IR-6 volts.

\*\* Rating is based on a brake time of (1) second. For increased operations per minute or longer brake time, consult factory.

#### SAFETY WARNING—PLEASE READ CAREFULLY

This product should be serviced by a qualified technician, electrician or electrical maintenance personnel familiar with its operation and the hazards involved. Proper installation (see instruction information which accompanies product), which includes wiring, mounting in proper enclosure, fusing or other overcurrent protection and grounding, can reduce the chance of electric shocks, fires or explosion in this product or products used with this product, such as electric motors, switches, coils, solenoids and/or relays. Eye protection must be worn and insulated adjustment tools must be used when working with control under power. This product is constructed of materials (plastics, metals, carbon, silicon, etc.) which may be a potential hazard. Individual material safety data sheets (MSDS) are available upon request. Proper shielding, grounding and filtering of this product can reduce the emission of radio frequency interference (RFI) which may adversely affect sensitive electronic equipment. If information is required on this product, contact our factory. It is the responsibility of the equipment manufacturer and individual installer to supply this safety warning to the ultimate user of this product. (SW effective 2/90.)

**TABLE 4. PLUG-IN HORSEPOWER RESISTOR® CHART**

MOTOR HORSEPOWER RANGE*		Plug-in Horsepower Resistor® Resistance Value (Ohms)**
Armature Voltage 90-130V DC	Armature Voltage 180V DC	
1/100-1/50	1/50-1/25	1.0
1/50-1/30	1/25-1/15	.51
1/30-1/20	1/15-1/10	.35
1/20-1/12	1/10-1/6	.25
1/12-1/8	1/6-1/4	.18
1/8-1/5	1/4-1/3	.1
1/4	1/2	.05
1/3	3/4	.035
1/2	1	.025
3/4	1-1/2	.015
1	2	.01
1-1/2	3	.006

\* Motor horsepower and armature voltage must be specified when ordering so that proper resistor will be supplied.

\*\* For overlapping motor horsepower range use lower value Plug-in Horsepower Resistor®

**FIG. 1 FEATURES AND FUNCTIONS**

- (1) Rugged Aluminum Heatsink
- (2) KBMM™ Speed Control\*
- (3) APRM® Reversing Module\*
- (4) AC Line Fuse
- (5) Armature Fuse
- (6) Barrier Terminal Block
- (7) Plug-in Horsepower Resistor® (supplied separately)
- (8) Trimpots: MIN, MAX, ACCEL, DECEL, IR and CL
- (9) Keyhole slots facilitate mounting
- (10) Aux. Trimpot for Speed Adjustment
- (11) Dynamic Brake Resistor

\* Patented

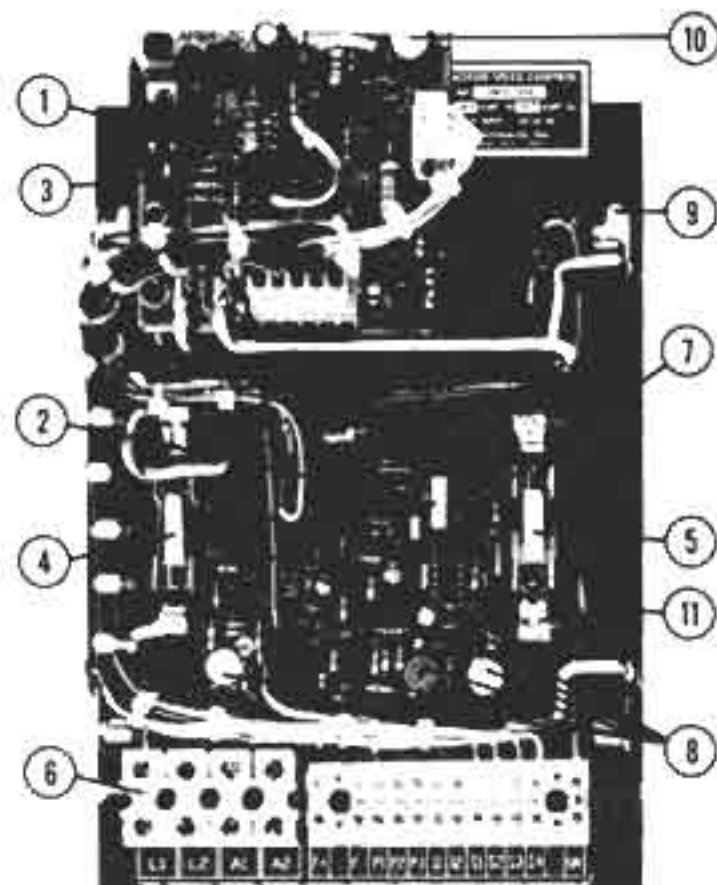

**Reversible (R-Suffix)**

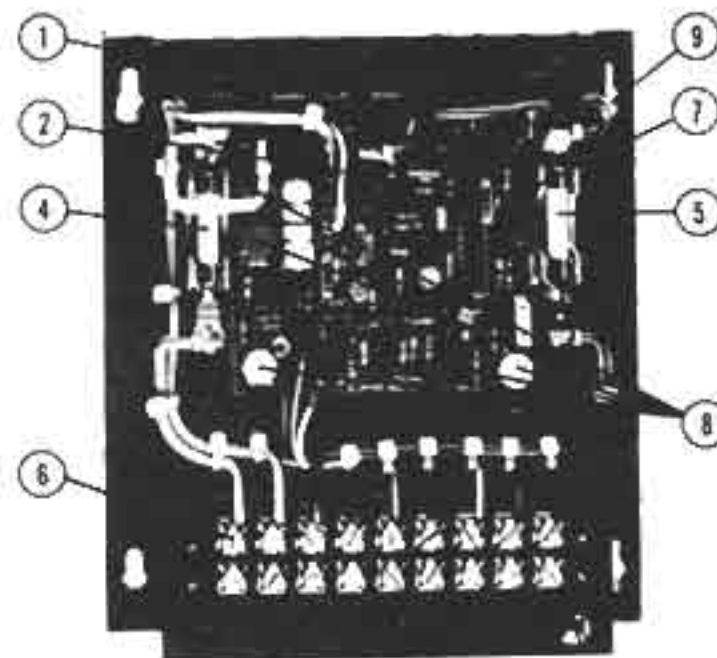

**Unidirectional**

## INTRODUCTION

The **NEW Patented Circuitry of the KBCC™** Full Wave Solid State DC Motor Speed Control represents the latest state-of-the-art design achievable through modern technology. (Short circuit proof and guaranteed not to cause motor demagnetization.)

### Features Include:

- **Integrated Circuitry**  
Used to control and amplify command and reference levels with both closed and open loop feedback to provide superior motor regulation. (Speed changes due to load, line voltage, or temperature variations are held to minimum levels.)
- **High Quality Components**  
Selected and tested for proven dependability.
- **Transient Protection**  
Used to prevent failure of the power bridge circuit caused by voltage spikes on the AC line.
- **High Reliability**  
When used in accordance with the instructions included in this manual, the KBCC® will provide years of trouble-free operation.

## SECTION I. GENERAL INFORMATION

**A. Motor Type.** The KBCC™ is designed for Permanent Magnet (PM) and Shunt Wound D.C. motors. Controls operated on 120 volt AC inputs are designed for 90 volt SCR rated motors. Controls operated on 240 volt AC inputs are designed for 180 volt SCR rated motors. Use of higher voltage motors will result in degradation of full speed performance. Also, if motor is not an SCR rated type, the actual AC line amperage at full load should not exceed the motor's DC nameplate rating.

**B. Torque Requirements.** When replacing an AC induction motor with a DC motor and speed control, consideration must be given to the maximum torque requirements. The full load torque rating of the DC motor must be equal to, or greater than, that of the AC motor.

**C. Acceleration Start.** The KBCC™ contains an adjustable acceleration start feature which allows the motor to smoothly accelerate from 0-full speed over a time period of .2-10 seconds. The "ACCEL" is factory set at 1 second.

**D. Limitations in Use.** The KBCC™ controls are designed for use on machine applications.

**E. Switching Applications:** "R" suffix models contain the KB APRM® which is designed to provide anti-plug instant reverse, solid state dynamic brake and rapid cycling. The maximum recommended number of run-brake cycles is 30 per minute. If higher rates are required, contact our sales department.

**CAUTION:** Consult factory before using on constant horsepower applications such as saws or drill presses. Do not use in explosive atmosphere.

**CAUTION:** Be sure the KBCC® is used within its max. ratings. Follow all installation instructions carefully (Refer to Section II.)

**CAUTION:** Be sure control is not used in extreme overhauling applications.

## SECTION II. INSTALLATION INSTRUCTIONS

**A. Location and Mounting.** The KBCC™ control should be mounted on a flat surface and located in an area where it will not be exposed to contaminants such as water, metal chips, solvents or excessive vibration.

When mounting in an enclosure the air space should be large enough to provide adequate heat dissipation. The maximum allowable ambient temperature at full rating is 45°C/113°F. Consult factory if more information is required.

**FIG. 2 MECHANICAL SPECIFICATIONS (inches)**

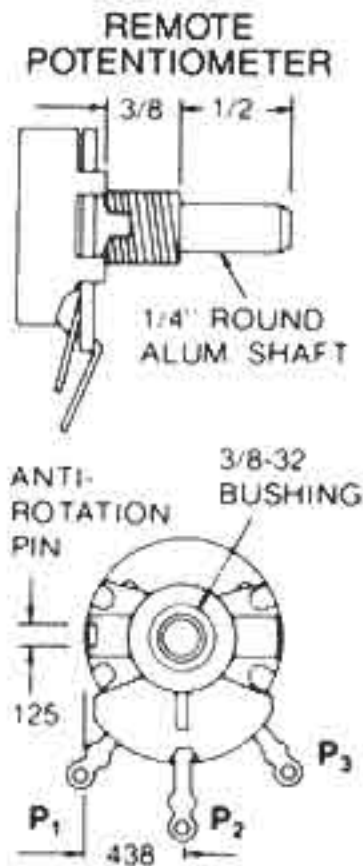
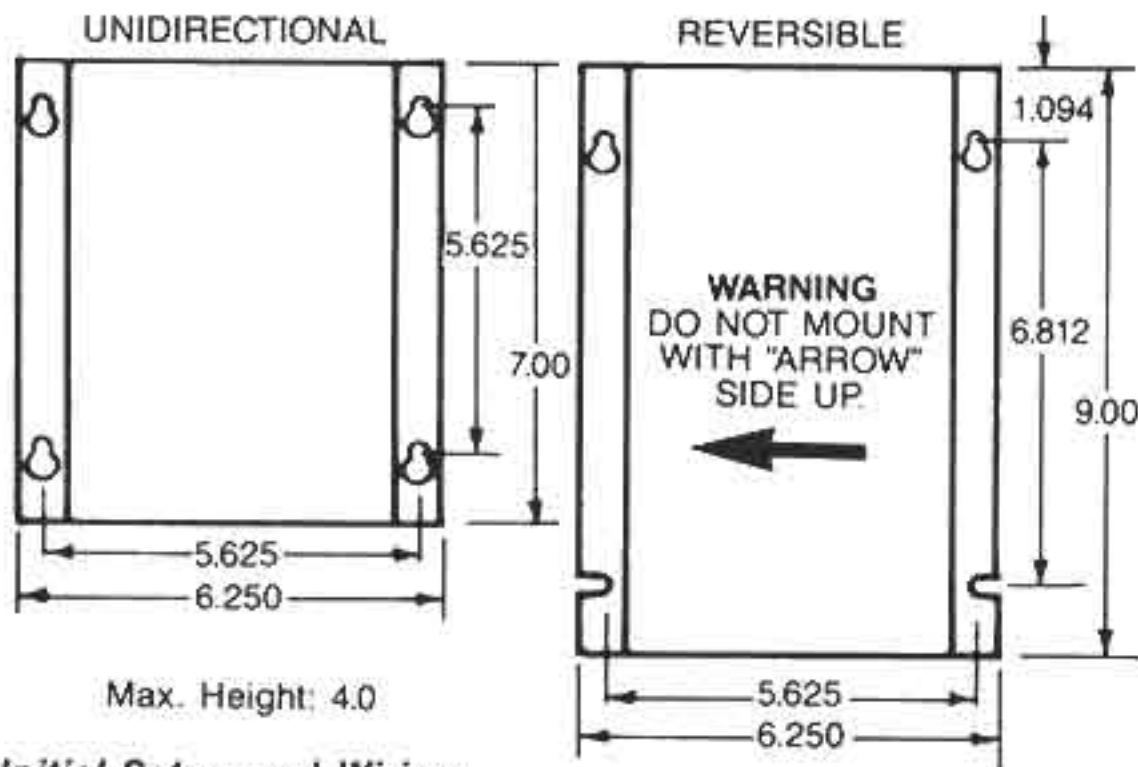

### B. Initial Setup and Wiring

1. Install proper size Plug-in Horsepower Resistor®. (See chart.)
2. The KBCC™ can be connected to a standard 120V or 240V 50/60 Hz AC line [Be sure the AC input voltage corresponds to the control voltage rating and the motor rating (e.g. 90–130VDC motor on 120VAC and 180VDC motor on 240VAC)].
3. Follow the recommended supply wire sizes as per Table 5.
4. Follow the NEC and other electrical codes that apply. CAUTION: Separate branch protection must be provided on 240V circuits. (Do not fuse neutral or grounded [earthed] conductors.)
5. Connect control according to connection diagram—See Fig. 3.

**TABLE 5. MINIMUM SUPPLY WIRE SIZE REQUIREMENTS**

MAX. MOTOR AMPS (DC AMPS)	MAX. MOTOR HP 90V	MAX. MOTOR HP 180V	MINIMUM WIRE SIZE (AWG) Cu Only	
			MAX. 50 FOOT RUN	MAX. 100 FOOT RUN
6.0	1/2	1	16	14
12.0	1	2	14	12*
16.0	1 1/2	3	12	12

\* Maximum recommended wire size.

**FIG. 3 CONNECTION DIAGRAM**

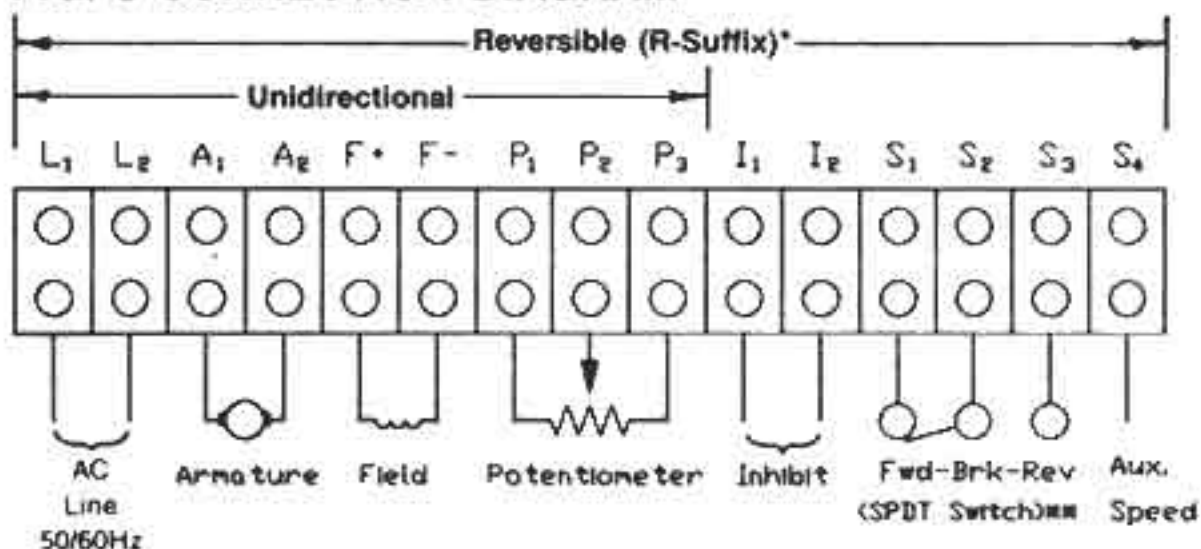

**REMOTE POTENTIOMETER**

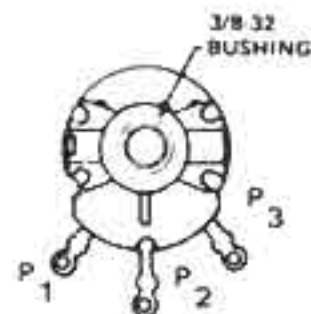

Notes \* R-Suffix models are equipped with the KB APRM<sup>®</sup>. For detailed connection diagrams see KBCC-R connection diagrams.  
 \*\* Since only 10 ma of current is switched, any switch or relay can be used except a solid state type or relays with capacitors or R-C networks (snubbers) across their contacts.

**CAUTION:** If control is wired to a transformer, it is advisable to switch the secondary to disconnect power. If the primary is switched, additional snubber capacitors may have to be added across the transformer output to prevent damage to the power bridge.

**CAUTION:** Do not bundle control wires P<sub>1</sub>, P<sub>2</sub>, P<sub>3</sub>, I<sub>1</sub>, I<sub>2</sub>, S<sub>1</sub>-S<sub>4</sub> with line or motor leads. If wires are over 18", use shielded cables.

**WARNING:** Armature Switching. Do not switch the armature in and out of circuit or catastrophic failure will result. If armature switching is required for dynamic brake or reversing, use "R" suffix models which contain the KB APRM<sup>®</sup>

### C. Voltage Following.

All models can be controlled with an isolated analog reference voltage (0-9VDC) in lieu of the main speed potentiometer. The voltage is connected to P<sub>2</sub>(+) and F-. The control output voltage will linearly follow the input voltage. The source impedance of the input should be 10K ohms or less. The Min trimpot is in circuit even without the main speed potentiometer. It can be used to provide an offset voltage, if desired. A 9 o'clock position of the Min trimpot is approximately zero volts. Max trimpot is rendered inoperative in the voltage following mode. Use an auxiliary trimpot for scaling and to limit the control range. If the input signal is not isolated, or is a current signal (4-20ma), the KBSI-240D Signal Isolator must be used. It will allow direct connection to process controllers and microprocessors.

**TABLE 6. ARMATURE FUSE CHART**

90VDC MOTOR	180VDC MOTOR	APPROX. DC MOTOR CURRENT (AMPS)	ARMATURE FUSE RATING (AMPS)
HORSEPOWER			
1/30	1/15	.33	1/2
1/20	1/10	.5	3/4
1/15	1/8	.65	1
1/12	1/6	.85	1-1/4
1/8	1/4	1.3	2
1/6	1/3	1.7	2-1/2
1/4	1/2	2.5	4
1/3	3/4	3.3	5
1/2	1	5.0	8
3/4	1-1/2	7.5	12
1	2	10.0	15
1-1/2	3	15.0	25*

\* Also used as AC Line Fuse.

**NOTE:** The AC line fuse is chosen according to the maximum rating of the control which is 25 amps.

**CAUTION:** 1. The voltage feeding P<sub>2</sub> and F- must be isolated from the AC line. Do not ground P<sub>2</sub> or F- to set up a zero or ground reference.  
2. Do not bundle signal wires to P<sub>2</sub> and F- with AC line or motor connections. If signal wires are over 18", use shielded cables.

### D. Fusing.

1. AC Line Fuse. The KBCC<sup>®</sup> contains a built-in replaceable AC line fuse rated 25A (Use Buss type MDA, ABC or 3 AG or equivalent.) The AC line fuse protects the control against catastrophic failure. If the fuse blows, the control is miswired, the motor is shorted or grounded, or the KBMM speed control is defective. On "R" suffix models, the APRM<sup>®</sup> may be defective.

2. **Armature Fuse.** The armature fuse provides overload protection for the motor and control. The KBCC<sup>®</sup> control contains fuses that are rated for the maximum horsepower. To provide proper protection for motors rated less than maximum, fuse at approximately 1.7 times the DC amperage rating of the motor. (See table.)

**NOTE:** Be sure to fuse each ungrounded AC line supply conductor. Do not fuse neutral or grounded conductors. See table 6 page 9.

### SECTION III—ADJUSTMENTS AND CONTROL FUNCTIONS

The KBCC<sup>®</sup> has been factory adjusted to provide 0-full speed using the speed control knob. Minimum and Maximum speed trimpots are provided to change the speed from other than 0-full speed. The Acceleration (ACCEL) trimpot is provided to allow for a smooth start over an adjustable time period each time the AC power is applied or the speed pot is rotated. The DECEL trimpot controls the amount of ramp down time when the speed pot is adjusted to a lower speed. The Current Limit (CL, or torque output) adjustment is factory set to approximately 1½ times the motor rating. The IR Compensation (IR) is factory adjusted to provide excellent motor regulation under normal operation. "R" suffix models contain the KB APRM<sup>®</sup> which provides anti-plug "instant" reverse and solid state dynamic braking. The APRM<sup>®</sup> contains a trimpot which is used to preset a fixed speed for either the forward or reverse direction (see KBCC-R connection diagrams for additional information).

**NOTE:** In order for the IR comp and CL trimpot settings to be correct, the proper Plug-in Horsepower Resistor<sup>®</sup> must be installed for the particular motor and input voltage being used. Do not attempt to change the settings of the trimpots unless absolutely necessary since they are factory adjusted to near optimum settings.

The following procedure, presented in order of adjustment sequence, should be used when readjusting all trimpot functions:

**Fig. 4 ACCEL/DECEL TRIMPOT ADJUSTMENT**

#### CAUTION!

[PM motors only.] Adjusting the accel time below .5 seconds increases inrush current. It may be necessary to measure the peak inrush current and consult with motor manufacturer since field magnet demagnetization may occur.

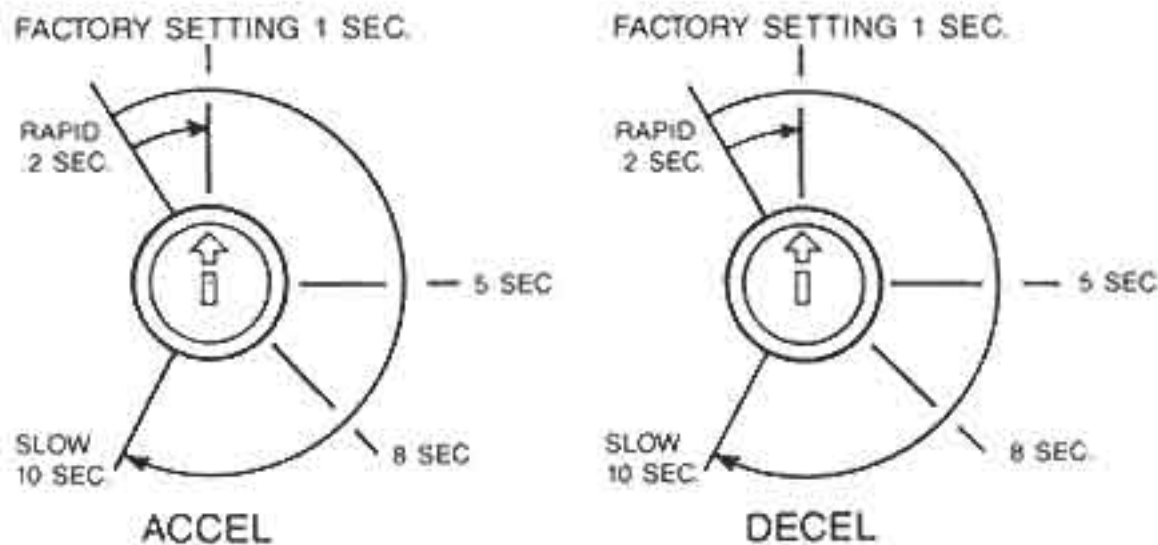

**A. Acceleration Start** The ACCEL is factory set at approx. 1 second. To readjust to different times, set the knob to the desired position as indicated in Fig. 4.

**B. Deceleration** The DECEL is factory set to provide minimum ramp-down time. To increase the ramp-down time adjust the DECEL trimpot as indicated in Fig. 4.

**C. Maximum Speed Adjustment.** Turn Speed Control Knob to full speed (maximum CW position). Adjust max. speed trimpot to new desired setting.

**NOTE:** Do not attempt to adjust the max. speed above the rated motor RPM since unstable motor operation may occur. For moderate changes in the max. speed, there will be a slight effect on the min. speed setting when the min. speed is set at zero. There may be a significant variation in the min. speed setting if the min. speed is at a higher than zero setting.

**D. Minimum Speed Adjustment.** If a higher than zero minimum speed is desired, readjust the minimum speed by turning the speed control knob to zero setting (full CCW position). Then adjust the min. speed trimpot to the desired setting.

**NOTE:** The min. speed adjustment will affect the max. speed setting. Therefore, it is necessary to readjust the max. speed after the min. speed, and it may be necessary to repeat the sequence until both the min. and max. speeds are set to the desired levels.

**E. Current Limit (CL/Torque Adjustment).** The *patented* CL circuitry is provided to protect the motor and control against overloads. The CL also protects against armature short circuits and motor demagnetization. It limits the inrush current to a safe level during startup. The CL is factory set to approximately 1.5 times the full load rating of the motor. (CL trimpot is nominally set to approx. 65% of full CW rotation.)

**LED CL Indicator**—after August 1990 all models will contain an LED on the speed control module. This lamp will light when the control is in the current limit mode.

**NOTE:** The correct value Plug-in Horsepower Resistor<sup>®</sup> must be installed in order for the CL and IR comp. to operate properly.

**To set the CL to factory specifications adjust as follows:**

1. Set speed control knob at approximately 30–50% CW rotation. Set CL trimpot to full CCW position.
2. Connect a DC ammeter in series with the armature lead.
3. Lock shaft of motor (be sure CL pot is in full CCW position). Apply power and rotate CL pot CW slowly until DC ammeter reads 1.5 times motor rating (do not exceed 2 times motor rating).

**NOTE:** If only an AC ammeter is available, it can be installed in series with AC input line. Follow above instructions; however, set AC amperage at .75 times motor rating.

**F. IR Compensation Adjustment.** IR compensation is provided to substantially improve load regulation. If the load presented to the motor does not vary substantially, the IR adjustment may be set

at a minimum level (approximately  $\frac{1}{4}$  of full setting). The control is factory adjusted to approximately 3% regulation. If superior performance is desired (less than 1% speed change of base speed from 0 to full load), then the IR comp. should be adjusted as follows:

**NOTE:** Excessive IR comp. will cause control to become unstable, which causes motor cogging.

1. Set IR comp. trimpot at approximately 25% of CW rotation. Run motor unloaded at approximately  $\frac{1}{3}$  speed and record RPM.
2. Run motor with maximum load and adjust IR comp. trimpot so that the motor speed under load equals the unloaded speed per step 1.
3. Remove load and recheck unloaded RPM. If unloaded RPM has shifted, repeat procedure for more exact regulation.

The KBCC is now compensated to provide minimal speed change under large variations of applied load.

## SECTION IV. APPLICATION INFORMATION

**A. INHIBIT<sup>®</sup>** All models contain Terminals  $I_1$  and  $I_2$  that provide an Inhibit<sup>®</sup> function which electronically extinguishes the output of the control. This circuit is activated by connecting the  $I_1$  and  $I_2$  terminals together. When installing the KBCC<sup>®</sup> be sure to follow the mounting and wiring instructions found in Sec. II.

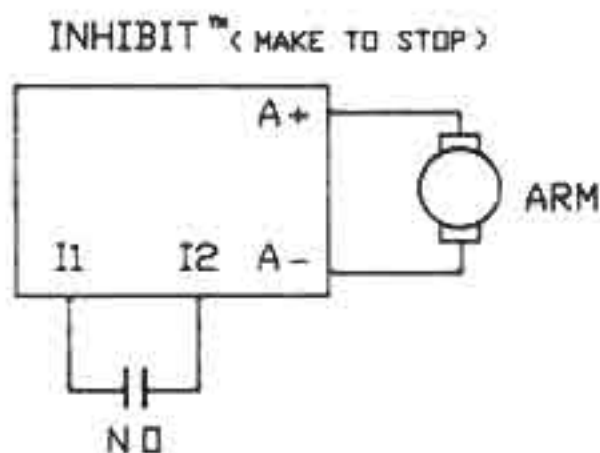

**B. Tachometer feedback (DC tachs only).** The load regulation of the control can be improved to 1% of set speed over a 50:1 speed range by use of tachometer feedback. Since no provision is made for the tach input on the terminal block, the tach positive connection must be made directly to the B or T terminal on the speed control module. **NOTE:** If control is used on a reversing application, the tach wires must also be reversed so that positive (+) is always connected to B or T. To set control for tachometer feedback:

(1) For tach feedback, cut jumper J1 on Printed Circuit Board.

(Note: On 240VAC models, J1 is an 82K resistor.)

(2) Connect tach as follows:

(a) 7 volts/1000 RPM Connect (+) lead to Terminal "T"  
Connect (-) lead to Terminal I<sub>2</sub> or F-

(b) 50 volts/1000 RPM Connect (+) lead to Terminal "B"  
Connect (-) lead to Terminal I<sub>2</sub> or F-

NOTE: Set IR Comp to minimum for tach feedback.

NOTE: The tachometer voltage input is based on 1,800 RPM motors. For motors other than 1,800 RPM, or for tachometer voltages other than what is specified, an external tachometer resistor must be used. Install the resistor ( $R_T$ ) in series with positive (+) tachometer lead and the 7V input on the control. The value of  $R_T$  may be calculated using the following formula.

$$R_T = [1.26 \times V_T \times S - 15,900]$$

$V_T$  = Tachometer voltage in volts/1,000 RPM

$S$  = Base speed of motor in RPM

Example: Suppose you have a 3,600 RPM motor with a 20 volt/1,000 RPM tachometer:

$$R_T = 1.26 \times 20 \times 3,600 - 15,900 = 74,820$$

Choose the closest 1/2 watt resistor value, which is 75,000; therefore,  $R_T = 75,000$ .

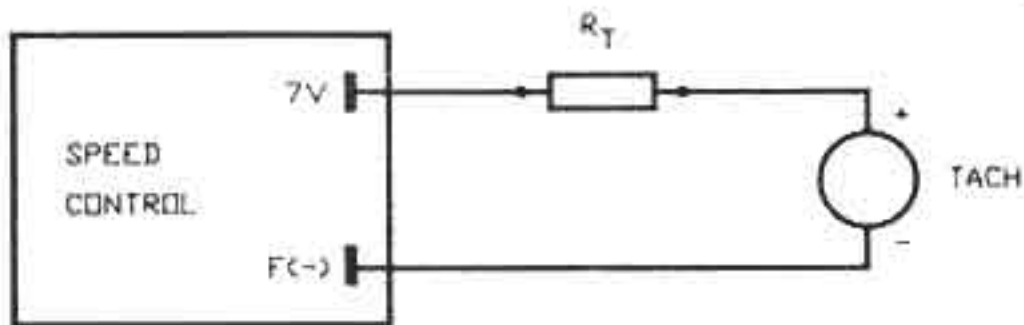

TACHOMETER CONNECTION WITH ADDITION OF  $R_T$

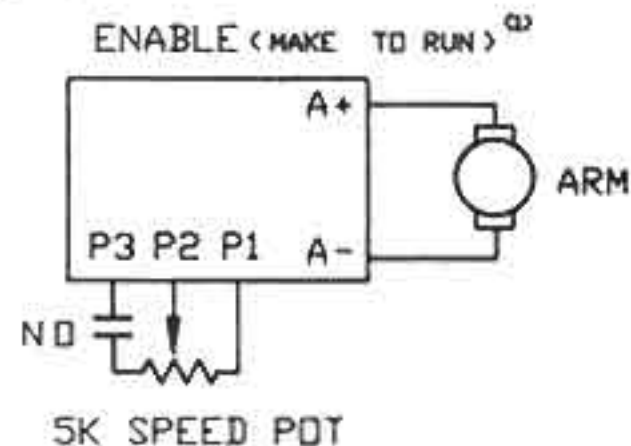

**C. Enable.** Control can be made to start and stop electronically with Enable. This circuit is "make to run" which is opposite of Inhibit<sup>®</sup>.

Stop time is adjustable with DECEL trimpot. To obtain 0 speed when Enable is open MIN speed trimpot must be set to 0 speed. Two-speed operation can be obtained by setting the MIN speed to the desired level.

**D. Switching Functions "R" Suffix Models Only.** The KBCC-R models are designed to offer a variety of switching functions. The APRM<sup>®</sup> module is the interface between command signals and the KBMM speed control module. By using terminals S<sub>1</sub>, S<sub>2</sub> and S<sub>3</sub> the KBCC-R models can be made to perform the following functions: Run-Brake, Forward-Brake-Reverse and Forward-Reverse (instant anti-plug reverse). Terminal S<sub>4</sub> is used to supply a control voltage which is adjustable with the APRM<sup>®</sup> trimpot R11. This voltage is used to preset a Jog or Run speed, either in Forward or Reverse direction. (DECEL Trimpot does not affect the brake time.)

In order for the KBCC-R control to drive a motor, S<sub>1</sub> and S<sub>2</sub> must be connected together for Forward and S<sub>2</sub> and S<sub>3</sub> must be connected together for Reverse. If no connection is made to S<sub>2</sub>, the control will be in a "Brake" mode. The brake circuit consists of an SCR and dynamic brake resistor (RB). An LED indicator on the APRM<sup>®</sup> shows that power is applied to the SCR gate. If braking is not required, the wire to RB may be disconnected. (Note that the LED will still light with RB disconnected.)

**IMPORTANT APPLICATION NOTE:** If the control is used in unidirectional operation only, such as Run-Brake, use the "Forward" direction (S<sub>1</sub>, S<sub>2</sub>). If motor runs opposite to the desired direction, then reverse the armature leads

**NOTE:** When switching terminals S<sub>1</sub>, S<sub>2</sub>, S<sub>3</sub>, approximately 10ma of current with full motor voltage may be present. Other terminals (I<sub>1</sub>, I<sub>2</sub>, P<sub>1</sub>, P<sub>2</sub>, P<sub>3</sub> and S<sub>4</sub>) are low voltage to each other, but line voltage to ground. Any switch or relay can be used for switching **except** solid state relays or contacts with R-C networks (snubbers). S<sub>1</sub> and S<sub>2</sub> must be opened before S<sub>2</sub> and S<sub>3</sub> are closed and vice versa

The following wiring diagrams are presented to demonstrate the capabilities of the KBCC-R.

**[1] Forward-Brake-Reverse with Single Potentiometer.** Use an SPDT ON-OFF-ON switch. Close S<sub>1</sub> and S<sub>2</sub> for motor to run in FWD direction. Open S<sub>2</sub> for Brake. Close S<sub>2</sub> and S<sub>3</sub> for motor to run in Reverse direction. If Brake position is not required, an SPDT (non-center OFF) may be used. This provides instant Anti-plug Reversing.

**DIA. [1]**

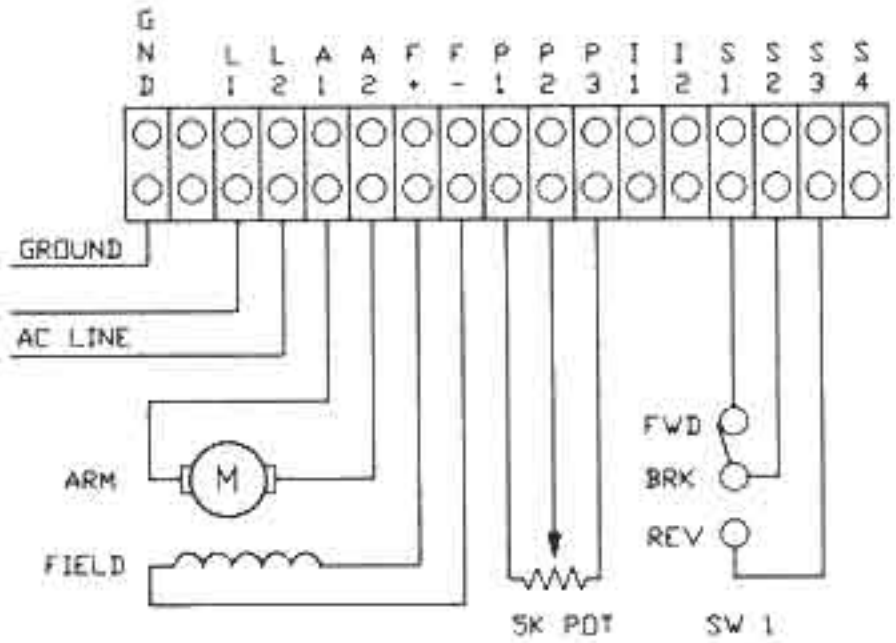

**[2] Forward-Brake-Reverse with Adjustable Reverse Speed.** Reverse speed is adjustable with the trimpot on the APRM<sup>®</sup> board. Use a DPDT ON-OFF-ON switch. In the Forward direction, the remote speed pot is used. In the Reverse direction, P<sub>2</sub> is connected to S<sub>4</sub> for speed adjustment. If Brake position is not required, a DPDT switch (non-center OFF) may be used. If, while in Forward or Reverse position, a separate Brake function is required, S<sub>2</sub> may be interrupted using a limit switch or relay. (For remote reverse speed pot adjustment, see Wiring Diagram 1.)

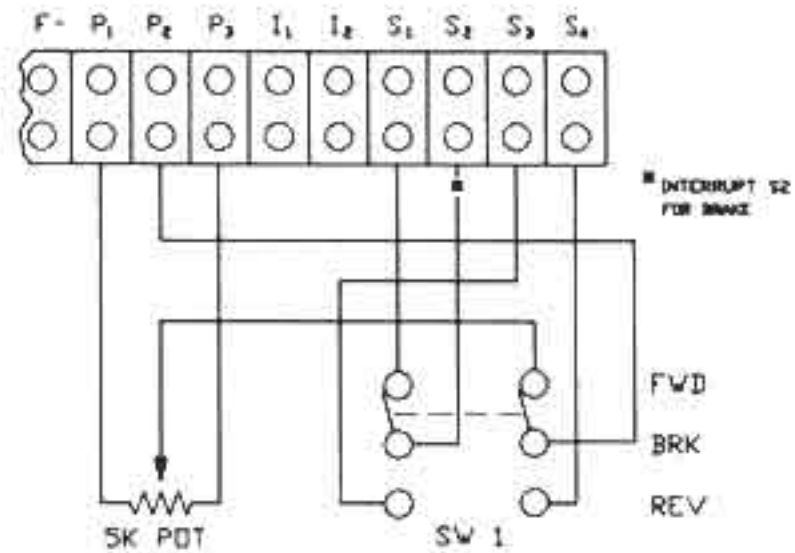

**DIA. [2]**

**[3] Forward-Brake-Reverse with Run-Brake-Jog.** Jog speed is adjusted with remote speed pot. For SW1 use an SPDT ON-OFF-ON switch. For SW2 use DPDT ON-OFF-ON with momentary return from Jog position. (For non-remote Jog speed use trimpot on APRM<sup>®</sup>, see Wiring Diagram 2.)

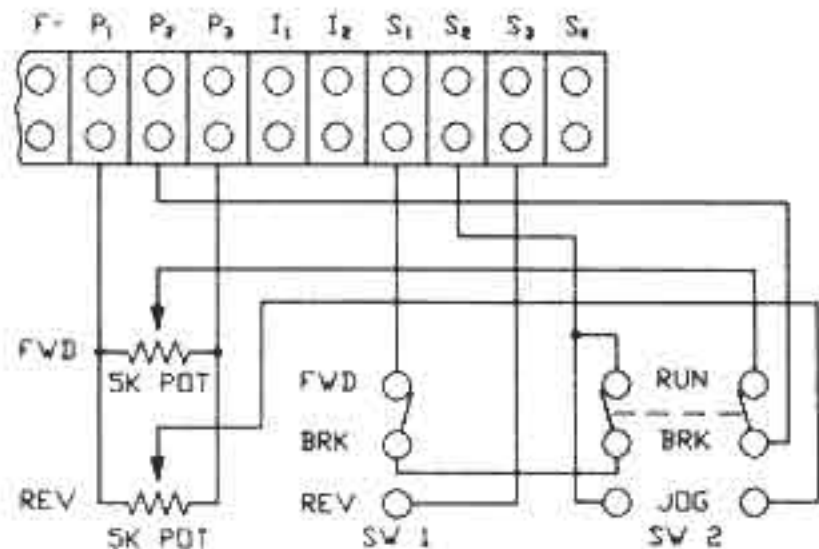

**DIA. [3]**

**[4] Run-Brake-Jog with Adjustable Jog Speed.** The Jog speed is adjustable with the trimpot on the APRM<sup>®</sup> board. Use a DPDT ON-OFF-ON switch. In the Run mode, the external 5K speed pot is used. In the Jog mode P<sub>2</sub> is connected to S<sub>4</sub> and the Jog pot, located on the APRM<sup>®</sup>, is used for speed adjustment. If Brake position is not required, a DPDT switch (non-center OFF) may be used. If, while in Forward or Jog position, a separate Brake function is required, S<sub>2</sub> may be interrupted using a limit switch or relay. (For remote reverse speed pot adjustment, see Wiring Diagram 3.)

[5] **Isolated Input for S<sub>1</sub>, S<sub>2</sub>, S<sub>3</sub>.** An isolator board SI-3 is available as an accessory. It allows the KBCC-R forward-brake-reverse function to be activated by an analog signal. The SI-3 installs by removing the 4-pin connector on the APRM. Install the SI-3 on the 4-pin header and plug the mating connector into the SI-3.

The SI-3 is activated by applying an analog voltage of 5-10VDC to terminals S<sub>1</sub>, S<sub>2</sub> for forward, or S<sub>3</sub>, S<sub>2</sub> for reverse. The KBCC-R with the SI-3 option is suitable for operation with programmable controllers. For complete isolation of the voltage following input Model KBSI-240 Signal Isolator should also be used.

FWD-BRK-REV CONTROL USING PROGRAMMABLE CONTROLLER

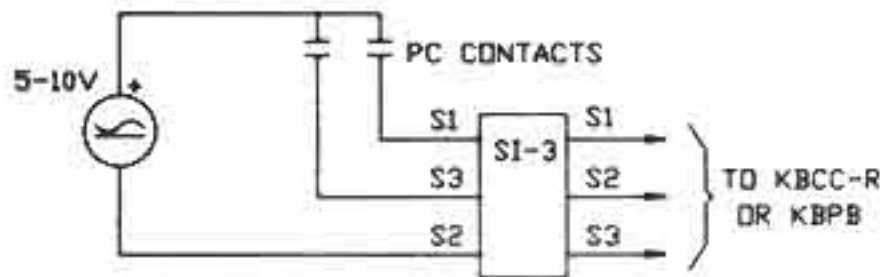

DIA. [4]

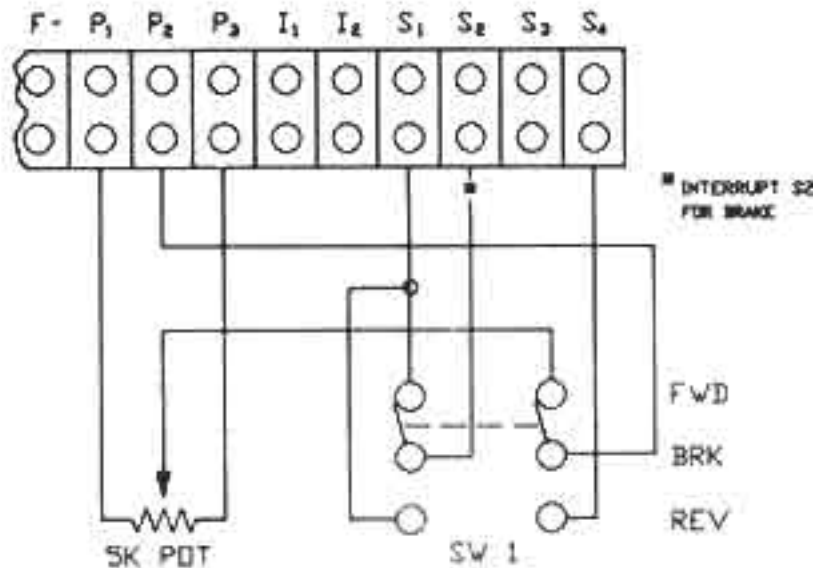

DIA. [5]

FWD-BRK-REV AND DUAL SPEED CONTROL

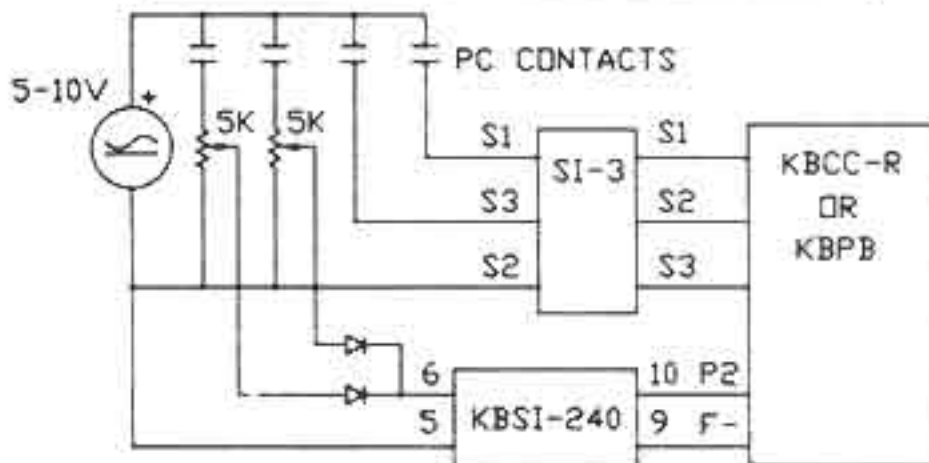

**[E] Overload Protection** The KBAP-240D is a multipurpose DC Current Sensing Relay and Overload Protector. It is specifically designed for use with DC motors and speed controls from 1/8–3 HP. The unit can be used with larger or smaller motors by utilizing the external method of connection. KBAP-240D operates by sensing current in the armature circuit. When the preset level is reached, an output relay trips. An adjustable time delay (.2–15 secs.) is incorporated, which eliminates nuisance tripping. Manual or automatic reset is provided at the user's option along with an LED, which indicates when the preset current level has been reached. In addition, a Hysteresis trimpot is provided which can be used to increase the differential between the pull-in and drop-out points of the output relay. When an overload occurs, the KBAP-240D can be used to shut the system down, sound an alarm, or initiate corrective action before damage occurs. The unit can be operated on either 120 or 240 VAC line voltage, and has five preset current trip points (2.5/5/10/15/20), which can be further adjusted with a built-in trimpot. See page 18 for connection diagram.

**REVERSING APPLICATIONS.** The KBAP set for Internal Sensing is suitable for unidirectional current only. Therefore, reversing controllers utilizing relays or reversing modules *cannot* be connected directly to the KBAP. For these applications the KBAP must be connected between the speed control and reversing module. For external Sensing the KBAP can be connected directly to the reversing control. See Fig. for correct connection diagrams (used for KB Models KBPB and KBCC-R suffix). See page 18 for connection diagram.

# Connections for Reversing Controllers

Internal Sensing (A)

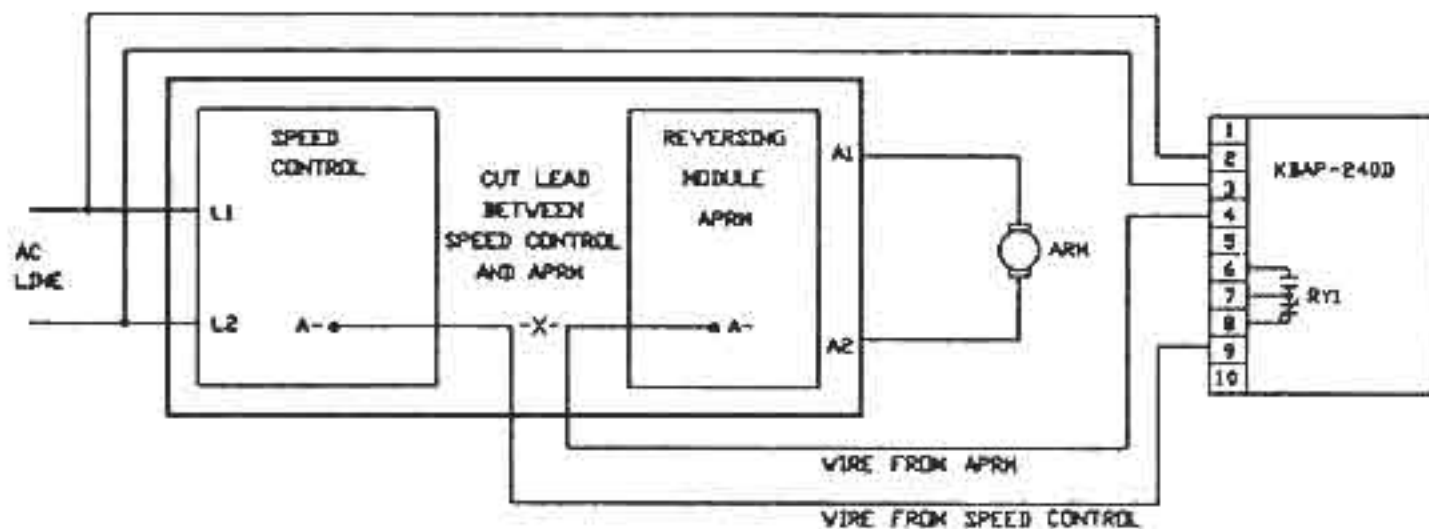

External Sensing (B)

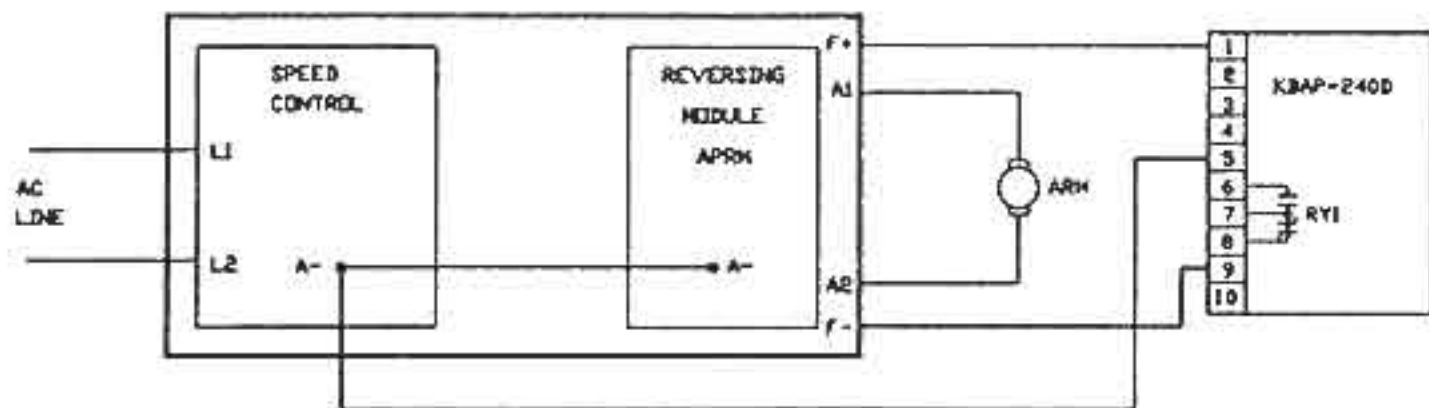

## SECTION V. TROUBLESHOOTING GUIDE

The following Troubleshooting Guide is intended for use by a qualified technician. The Guide is designed to isolate common malfunctions of the KBPB and/or motor. It should be used with the parts lists and schematics contained in this manual.

SYMPTOM	POSSIBLE CAUSE	CORRECTIVE ACTION
1. Motor does not run.	<ol style="list-style-type: none"><li>1. AC voltage not brought to L1, L2 terminals.</li><li>2. Blown line or armature fuse.</li><li>3. Speed control knob set to 0.</li><li>4. Defective motor.</li><li>5. Plug-In Horsepower Resistor* not installed.</li></ol>	<ol style="list-style-type: none"><li>1. Correct wiring to control.</li><li>2. Replace blown fuse with properly rated 3AB-type. If fuse blew due to miswiring, speed control module may be defective.</li><li>3. Turn knob CW to start motor.</li><li>4. Check for defective motor, worn brushes, etc. Replace motor.</li><li>5. Install proper size Plug-In Horsepower Resistor*</li></ol>
2. Motor hums, or runs at very low speed (with control knob set at high number) or motor slows down substantially when load is applied.	<ol style="list-style-type: none"><li>1. Low voltage.</li><li>2. Overload condition; control in current limit mode (CL) (trimpot not set correctly).</li><li>3. Plug-in Horsepower Resistor* not correct size.</li><li>4. Incorrect wiring. Armature and shunt connections interchanged (shunt motor only).</li></ol>	<ol style="list-style-type: none"><li>1. Check line voltage at control and rewire as required.</li><li>2. Reduce loading; CL trimpot setting may have to be increased. See Section IV.</li><li>3. Install proper size resistor.</li><li>4. Correct wiring (armature has lower resistance than field).</li></ol>
3. Erratic motor performance.	<ol style="list-style-type: none"><li>1. Defective motor, worn brushes etc.</li><li>2. Overload condition.</li><li>3. Plug-in Horsepower Resistor* wrong size.</li><li>4. IR comp and/or CL trimpots not set properly.</li><li>5. Defective speed control module.</li></ol>	<ol style="list-style-type: none"><li>1. Repair motor.</li><li>2. Remove overload.</li><li>3. Replace with proper size.</li><li>4. Readjust trimpots as per Section IV.</li><li>5. Replace module.</li></ol>
4. Motor continues to run when speed control knob is set to 0.	<ol style="list-style-type: none"><li>1. Min speed trimpot not set to full CCW position.</li><li>2. IR comp trimpot set too high.</li></ol>	<ol style="list-style-type: none"><li>1. Readjust min. trimpot.</li><li>2. Lower IR comp trimpot setting.</li></ol>
5. Motor runs in wrong direction.	<ol style="list-style-type: none"><li>1. Armature leads reversed.</li></ol>	<ol style="list-style-type: none"><li>1. Reconnect armature leads.</li></ol>

The following portion of the Troubleshooting Guide refers to "R"-suffix models only.

1. Motor will not run in either forward or reverse direction.	<ol style="list-style-type: none"><li>1. Incorrect wiring or faulty reversing switch.</li><li>2. Defective APRM* .</li></ol>	<ol style="list-style-type: none"><li>1. Correct wiring. See KBCC-R connection diagrams.</li><li>2. Replace APRM* .</li></ol>
2. No Braking action in brake mode.	<ol style="list-style-type: none"><li>1. Incorrect wiring.</li><li>2. Defective brake resistor.</li><li>3. Defective APRM* .</li></ol>	<ol style="list-style-type: none"><li>1. Correct wiring.</li><li>2. Replace resistor.</li><li>3. Replace APRM* .</li></ol>

FIG. 5 INTERNAL CONNECTION DIAGRAM

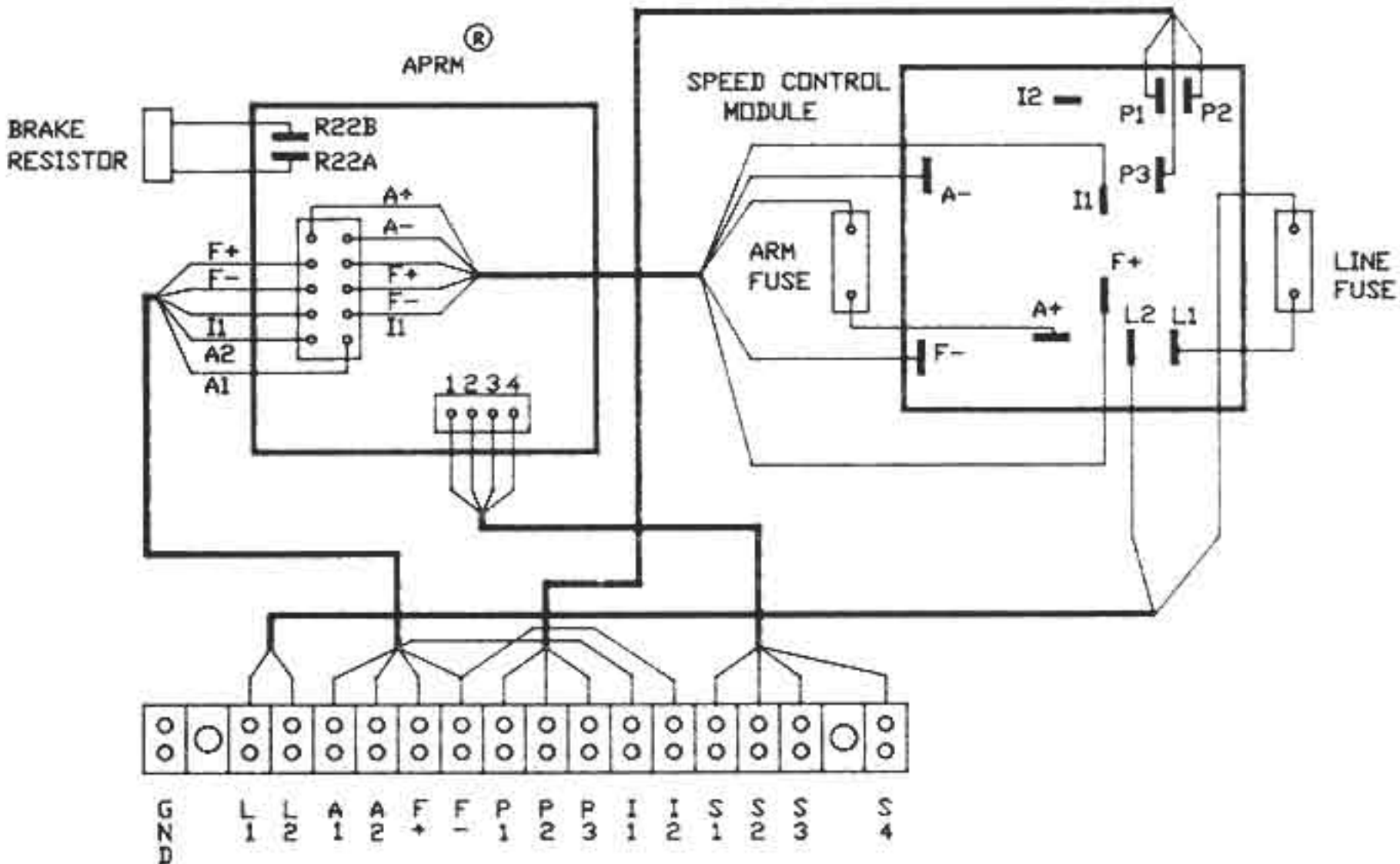

# SECTION VI. (B) SPEED CONTROL MODULE SCHEMATIC\*

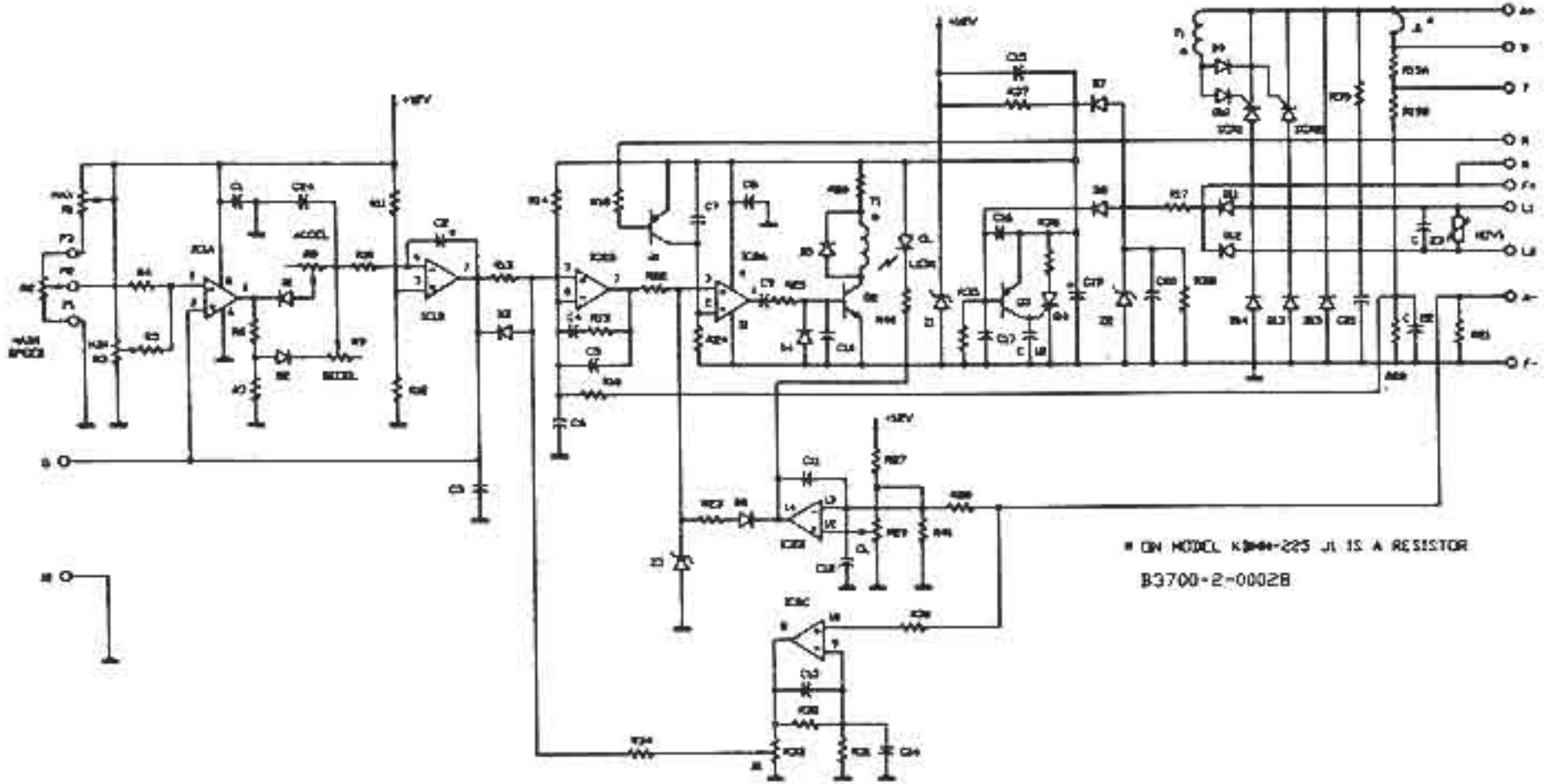

\* ON MODEL K200-225 J1 IS A RESISTOR  
B3700-2-0002B

SECTION IV. (C) APRM® SCHEMATIC—(patented)

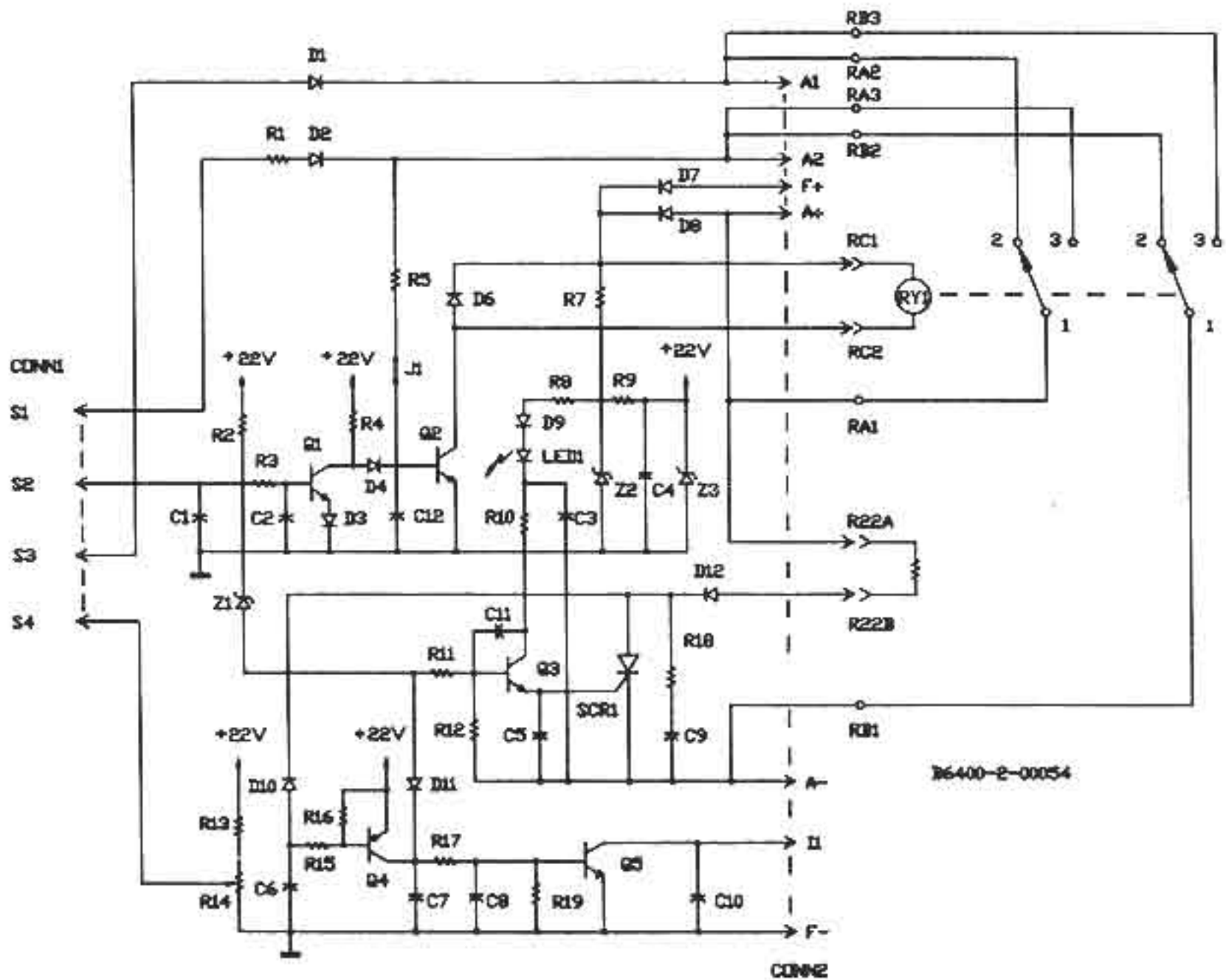

B6400-2-00054

## SEC. VI. MODEL KBMM-125 PARTS LIST

CKT. REF.	VALUE/RATING	MFG. TYPE	FUNCTION	PART NO.
C1	0.01ufd-25V	Ceramic Tubular	Capacitor	A14831
C2	1.5ufd-50V	Electrolytic	Capacitor	A13215
C3	0.47ufd-50V	Film/lytic	Capacitor	A12500
C4	0.33ufd-50V	Metal Film	Capacitor	A10233
C5	0.033ufd-50V	Metal Film	Capacitor	A10203
C6,8,10,24	0.022ufd-25V	Ceramic Axial	Capacitor	A14832
C7	0.1ufd-50V	Metal Film	Capacitor	A10210
C9,11,13	0.01ufd-50V	Metal Film	Capacitor	A10201
C12	0.015/0.022ufd-25V	Ceramic Axial	Capacitor	A14833
C14-16,18	0.01ufd-25V	Ceramic Axial	Capacitor	A14831
C17	4.7ufd-35V	Electrolytic	Capacitor	A13355
C19	100.0-ufd-35V	Electrolytic	Capacitor	A13701
C20	0.047ufd-50V	Metal Film	Capacitor	A10205
C21,23	0.1ufd-250V	Metal Film	Capacitor	A10210
C22	0.022ufd-50V	Metal Film	Capacitor	A10202
D1-D10	1A-600PIV	1N4005GP	Diode	A68016
D11,12	1.5A-600PIV	1N5397GP	Diode	A68019
D13, D14	25A-600PIV	D6025L	Power Diode	A68062
D15	15A-600PIV	D6015L	Power Diode	A68061
IC1		LM358P	Dual Op-Amp	A73002
IC2		LM324N	Quad Op-Amp	A73004
J1	22 AWG		Jumper	A88822
LED1	35MA-30mcd	MV5753	CL Indicator	A74022
MOV1	150VRMS	V150LA10A	Transient Suppressor	A68100
Q1,3	600mA-40V	2N4403	Bipolar Transistor	A71002
Q2	600mA-40V	2N4401	Bipolar Transistor	A71001
Q4	800mA-50V	S347S101E	Small Signal SCR	A69008
R1	10K-0.33W-10%	PTC-10YV	Max Trimpot	A60613
R2	5K-5W-10%		Main Speed Pot	A60202
R3	25K-0.33W-20%	PTC-10YV	Min Trimpot	A60614
R4	33K-0.25W-5%	Carbon Film	Resistor	A62333
R5,16,18,27	47K-0.25W-5%	Carbon Film	Resistor	A62347
R6	24K-0.25W-5%	Carbon Film	Resistor	A62324
R7,12	3.3K-0.25W-5%	Carbon Film	Resistor	A62233
R8	500K-0.33W-10%	PTC-10YV	Accel Trimpot	A60618
R9	500K-0.33W-10%	PTC-10YV	Decel Trimpot	A60618
R10,41	1K-0.25W-5%	Carbon Film	Resistor	A62210
R11	50K-0.25W-5%	Carbon Film	Resistor	A62356
R13,23,35	22K-0.25W-5%	Carbon Film	Resistor	A62322
R14,32	2.2M-0.25W-5%	Carbon Film	Resistor	A62522
R15	1M-0.25W-5%	Carbon Film	Resistor	A62510
R17	4.7K-3W-5%	MO-3	Resistor	A67001
R19A	62K-0.25W-5%	Carbon Film	Resistor	A62362
R19B	12K-0.25W-5%	Carbon Film	Resistor	A62312
R20	3.9K-0.25W-5%	Carbon Film	Resistor	A62239
R21*	0.006 ohm-1.0 ohm-5W-5%	Wire Wound	Plug-in-Horsepower Resistor	
R22,24,34	100K-0.25W-5%	Carbon Film	Resistor	A62410

**SEC. VI. MODEL KBMM-125 PARTS LIST** Continued

CKT. REF.	VALUE/RATING	MFG. TYPE	FUNCTION	PART NO.
R25	3.3K-0.25W-5%	Carbon Film	Resistor	A62233
R26	47 ohm-0.25W-5%	Carbon Film	Resistor	A62047
R28,30,31	47K-0.25W-5%	Carbon Film	Resistor	A62347
R29	25K-0.33W-20%	PTC-10YV	CL Trimpot	A60614
R33	10K-0.33W-20%	PTC-10YV	IR Trimpot	A60613
R36	1.0 ohm-0.25W-5%	Carbon Comp.	Resistor	A61041
R37	1.8K-0.25W-5%	Carbon Film	Resistor	A62218
R38	6.8K-0.25W-5%	Carbon Film	Resistor	A62268
R39	1K-0.25W-5%	Flameproof	Resistor	A62601
R40	4.7K-0.25W-5%	Carbon Film	Resistor	A62247
SCR1,2	25A-600V	S6025L	Power SCR	A69256
T1	1:1	KB Standard	Pulse Transformer	A84002
Z1	12V-1W-5%	1N4742A	Zener Diode	A72012
Z2	22V-1W-5%	1N4748A	Zener Diode	A72022
Z3	18V-1W-5%	1N4746A	Zener Diode	A72018

\* Components whose value/rating may vary with application.

**SEC. VII. MODEL KBMM-225 PARTS LIST**

CKT. REF.	VALUE/RATING	MFG. TYPE	FUNCTION	PART NO.
C1	0.01ufd-25V	Ceramic Tubular	Capacitor	A14831
C14-16,18	0.01ufd-25V	Ceramic Tubular	Capacitor	A14831
C2	1.5ufd-50V	Electrolytic	Capacitor	A13215
C3	0.47ufd-50V	Film/lytic	Capacitor	A12500
C4	0.33ufd-50V	Metal Film	Capacitor	A10233
C5	0.033ufd-50V	Metal Film	Capacitor	A10203
C6,8,10,12,24	0.022ufd-25V	Ceramic Tubular	Capacitor	A14832
C7	0.1ufd-50V	Metal Film	Capacitor	A10210
C9,11,13	0.01ufd-50V	Metal Film	Capacitor	A10201
C17	4.7ufd-35V	Electrolytic	Capacitor	A13355
C19	100.0-ufd-35V	Electrolytic	Capacitor	A13701
C20	0.047ufd-50V	Metal Film	Capacitor	A10205
C21	0.047ufd-400VDC	Metal Film	Capacitor	A10404
C22	0.022ufd-50V	Metal Film	Capacitor	A10202
C23	0.047ufd-250VAC/630VDC	Rifa or Wima	Capacitor	A14547
D1-D10	1A-600V	1N4005GP	Diode	A68016
D11,12	1.5A-600V	1N5397GP	Diode	A68019
D13, D14	25A-600V	D6025L	Power Diode	A68062
D15	15A-600V	D6015L	Power Diode	A68061
IC1		LM358P	Dual Op-Amp	A73002
IC2		LM324	Quad Op-Amp	A73004
J1	82K-0.25W-5%	Carbon Film	Resistor	A62382
LED1	35MA-30mcd	MV57S3	CL Indicator	A74022
Q1,3	0.6A-40V	2N4403	Small Signal Transistor	A71002
Q2	0.6A-40V	2N4401	Small Signal Transistor	A71001
Q4	0.8A-50V	S347S101E	Small Signal SCR	A69008
R1	10K-0.33W-10%	PTC-10YV	Max Trimpot	A60613
R2	5K-5W-20%		Main Speed Pot	A60202
R3	25K-0.33W-10%	PTC-10YV	Min Trimpot	A60614
R4	33K-0.25W-5%	Carbon Film	Resistor	A62333
R5,16,18,27	47K-0.25W-5%	Carbon Film	Resistor	A62347
R28,30,31	47K-0.25W-5%	Carbon Film	Resistor	A62347

## SEC. VII. MODEL KBMM-225 PARTS LIST Continued

CKT. REF.	VALUE/RATING	MFG. TYPE	FUNCTION	PART NO.
R6	24K-0.25W-5%	Carbon Film	Resistor	A62324
R7,12	3.3K-0.25W-5%	Carbon Film	Resistor	A62233
R8	500K-0.33W-10%	PTC-10YV	Accel Trimpot	A60618
R9	500K-0.33W-10%	PTC-10YV	Decel Trimpot	A60618
R10,41	1K-0.25W-5%	Carbon Film	Resistor	A62210
R11	56K-0.25W-5%	Carbon Film	Resistor	A62356
R13,23,35	22K-0.25W-5%	Carbon Film	Resistor	A62322
R14,32	2.2M-0.25W-5%	Carbon Film	Resistor	A62522
R15	1M-0.25W-5%	Carbon Film	Resistor	A62456
R19A	62K-0.25W-5%	Carbon Film	Resistor	A62362
R19B	12K-0.25W-5%	Carbon Film	Resistor	A62312
R20	3.9K-0.25W-5%	Carbon Film	Resistor	A62239
R21*	0.006 ohm-1.0 ohm-5W-5%	Wire Wound	Plug-in-Horsepower Resistor	
R22,24,34	100K-0.25W-5%	Carbon Film	Resistor	A62410
R25	3.3K-0.25W-5%	Carbon Film	Resistor	A62233
R26	47 ohm-0.25W-5%	Carbon Film	Resistor	A62047
R29	25K-0.33W-10%	PTC-10YV	CL Trimpot	A60614
R33	10K-0.33W-10%	PTC-10YV	IR Trimpot	A60613
R36	1.0 ohm-0.25W-5%	Carbon Comp.	Resistor	A61041
R37	1.8K-0.25W-5%	Carbon Film	Resistor	A62218
R38	6.8K-0.25W-5%	Carbon Film	Resistor	A62268
R39	1K-0.25W-5%	Flameproof	Resistor	A62610
R40	4.7K-0.25W-5%	Carbon Film	Resistor	A62247
SCR1,2	25A-600V	S6025L	Power SCR	A69256
T1	1:1	KB Standard	Pulse Transformer	A84002
Z1	12V-1W-5%	1N4742A	Zener Diode	A72012
Z2	22V-1W-5%	1N4748A	Zener Diode	A72022
Z3	18V-1W-5%	1N4746A	Zener Diode	A72018

\* Component whose value and/or rating may change with application.

## SEC. VIII. APRM-2C-120V PARTS LIST

CKT. REF.	VALUE/RATING	MFG. TYPE	FUNCTION	PART NO.
C1,11,12	0.01MF-200V-20%	Ceramic Disc	Capacitor	A14805
C2,5,6	0.01MF-50V-20%	Ceramic Axial	Capacitor	A14831
C3	10.0MF-100V-20%	Electrolytic	Capacitor	A13720
C4	15.0MF-35V-20%	Electrolytic	Capacitor	A13365
C7	1.5MF-35V-20%	Electrolytic	Capacitor	A13215
C8,10	0.47MF-50V-20%	Electrolytic	Capacitor	A13346
C9	0.1MF-250V-20%	Metal Film	Capacitor	A10210
D1-4,6-11	1A-600PIV	1N4005GP	Diode	A68016
D12	5A-500PIV	A15E	Diode	A68055
J1	22 AWG		Jumper	A88822

## SEC. VIII. APRM-2C-120V PARTS LIST Continued

CKT. REF.	VALUE/RATING	MFG. TYPE	FUNCTION	PART NO.
LED1	35mA-30mcd	MV5753	Brake Indicator	A74022
Q1,5	600mA-40V	2N4401	Bipolar Transistor	A71001
Q2,3	300mA-350V	MPSA45	Bipolar Transistor	A71014
Q4	600mA-40V	2N4403	Bipolar Transistor	A71002
R1	1.5K-0.25W-5%	Carbon Film	Resistor	A62215
R2	5.6K-0.25W-5%	Carbon Film	Resistor	A62256
R3,8	15K-0.25W-5%	Carbon Film	Resistor	A62315
R4,11	10K-0.25W-5%	Carbon Film	Resistor	A62310
R5	15K-5W-5%	Wire Wound	Resistor	A67007
R6	39K-0.25W-5%	Carbon Film	Resistor	A62339
R7	3.3K-2W-5%	MO-2	Resistor	A66633
R9	4.7K-1W-5%	MO-1	Resistor	A65517
R10,18	470 ohm-0.25W-5%	Flameproof	Resistor	A62601
R11	10K-0.25W-5%	Carbon Film	Resistor	A62310
R12,15,19	22K-0.25W-5%	Carbon Film	Resistor	A62322
R13,16	4.7K-0.25W-5%	Carbon Film	Resistor	A62247
R14	10K-0.33W-20%	Piher-PTC10YV	Jog Trimpot	A60613
R17	33K-0.25W-5%	Carbon Film	Resistor	A62333
R22*		Wire Wound	Brake Resistor	
RY1	20A-110VDC	PBS87R11D2B1D1	DPDT Relay	A77821
SCR1	15A-600V	S6015L	Power SCR	A69158
Z1	7.5V-0.5W-5%	1N5236B	Zener Diode	A72007
Z2	75V-1W-5%	1N4761A	Zener Diode	A72075
Z3	22V-1W-5%	1N4748A	Zener Diode	A72022

### CHANGES REQUIRED FOR APRM-2C-240V

R7	10K-3W-5%	MO3	Resistor	A66762
RY1	20A-220VDC	PBS87R11D2B1D1	DPDT Relay	A77822

\* Component whose value and/or rating may change with application.

### \*R22 USAGE BY MODEL

Model	Value (ohms)	Wattage	Part No.
KBPB-125	10 ohm	30W	A67247
KBPB-225	20 ohm	60W (2-10 ohm-30W in Series)	A67247
KBCC-125R	10 ohm	70W	A67310
KBCC-225R	20 ohm	140W (2-10 ohm-70W in Series)	A67310
KBPC-116MRJ	10 ohm	50W (2-5 ohm-25W in Series)	A67205
KBPC-216MRJ	20 ohm	50W (2-10 ohm-25W in Series)	A67210

## OTHER ITEMS FOR KBCC AVAILABLE FROM YOUR DISTRIBUTOR



KBAP-240D  
Part No. 9106



Knob/Dial Kit  
Part No. 9832



Potentiometer Kit  
Part No. 9831



KBSI-240D  
Signal Isolator  
Part No. 9431



SI-3 Isolator  
for  $S_1, S_2, S_3$   
Part No. 9447

### LIMITED WARRANTY

For a period of 18 months from date of original purchase KB will repair or replace without charge devices which our examination proves to be defective in material or workmanship. This warranty is valid if the unit has not been tampered with by unauthorized persons, misused, abused, or improperly installed and has been used in accordance with the instructions and/or ratings supplied. The foregoing is in lieu of any other warranty or guarantee expressed or implied, and we are not responsible for any expense (including installation and removal), inconvenience, or consequential damage, including injury to any person, caused by items of our manufacture or sale. Some states do not allow certain exclusions or limitations found in this warranty so that they may not apply to you. In any event, KB's total liability, under all circumstances, shall not exceed the full purchase price of this unit. (Rev. 10/84)

The information contained in this brochure is intended to be accurate. However, the manufacturer retains the right to make changes in design which may not be included herein.



**KB ELECTRONICS, INC.**

12095 NW 39th Street, Coral Springs, FL 33065 • (954) 346-4900 • Fax (954) 346-3377

Outside Florida Call TOLL FREE (800) 221-6570 • Email – [info@kbelectronics.com](mailto:info@kbelectronics.com) •

[www.kbelectronics.com](http://www.kbelectronics.com)