

USERGUIDE

M DRIVE



WARNING - Reliance on this Manual Could Result in Severe Bodily Injury or Death!

This manual is out-of-date and is provided only for its technical information, data and capacities. Portions of this manual detailing procedures or precautions in the operation, inspection, maintenance and repair of the product forming the subject matter of this manual may be inadequate, inaccurate, and/or incomplete and cannot be used, followed, or relied upon. Contact Conair at info@conairgroup.com or 1-800-654-6661 for more current information, warnings, and materials about more recent product manuals containing warnings, information, precautions, and procedures that may be more adequate than those contained in this out-of-date manual.

INTRODUCTION

The M-Drive is a very accurate digital motor speed drive which offers advanced internal software for solving many speed control tasks. It is packaged in a 1/2 DIN enclosure, and is designed for both stand-alone control of a single motor, or as part of a more complex multi-motor drive system. Some of the advanced capabilities of the M-Drive are 4 preset setpoints to allow quick change of conditions, multiple formats for calculating speed control commands, and the capability to provide accurate drive control of DC permanent magnet or field wound motors from 1/4 to 2 horsepower.

Although the M-Drive contains many advanced features, it has also been designed to be easy to use. The sealed keypad divides into two panels: a panel for day-to-day operations, and a panel behind a separate door containing programming functions. Dedicated keys are provided for SET SPEED and TACH. Also, the M-Drive contains an RS-422 communications port, thereby allowing communications between the M-Drive and a host computer.

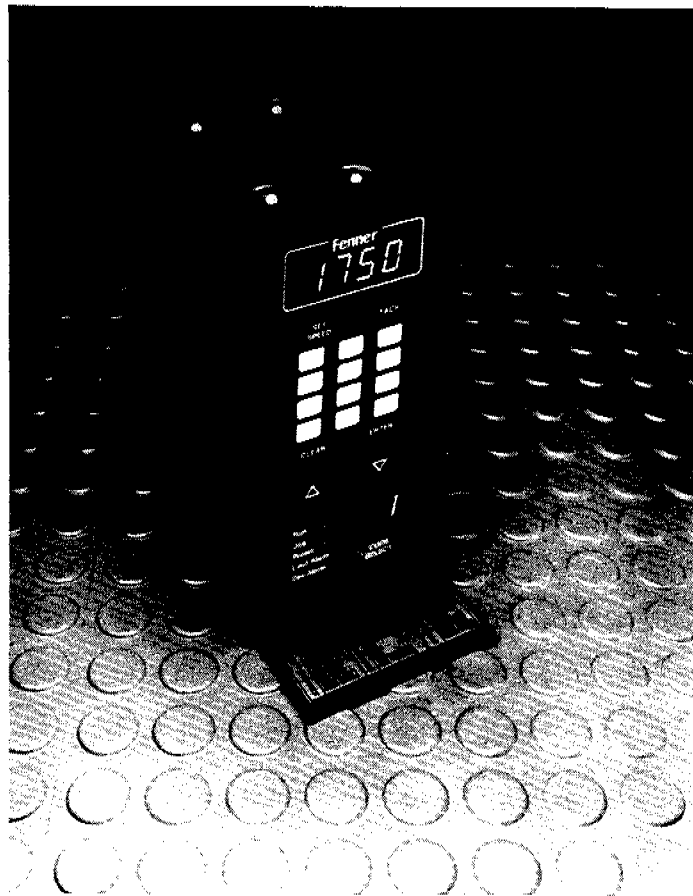

Figure 1-1: M-Drive

EXAMPLE IMPLEMENTATION

The M-Drive is often used in motor control applications where open loop or rudimentary closed loop (i.e., armature feedback) techniques provide insufficient accuracy or inadequate load regulation. Other candidate situations are those requiring one part of a process to "follow" or be "paced" by another part of the process. Many of these problems can be solved by the addition of the M-Drive together with a suitable feedback element to the motor or drive shaft.

In a basic M-Drive implementation, the M-Drive is inserted in place of the original armature feedback or open loop motor drive. The required digital feedback is typically provided by a magnetic sensor on the motor frame and a gear mounted on the motor shaft.

Figure 1-2 below illustrates this basic M-Drive implementation.

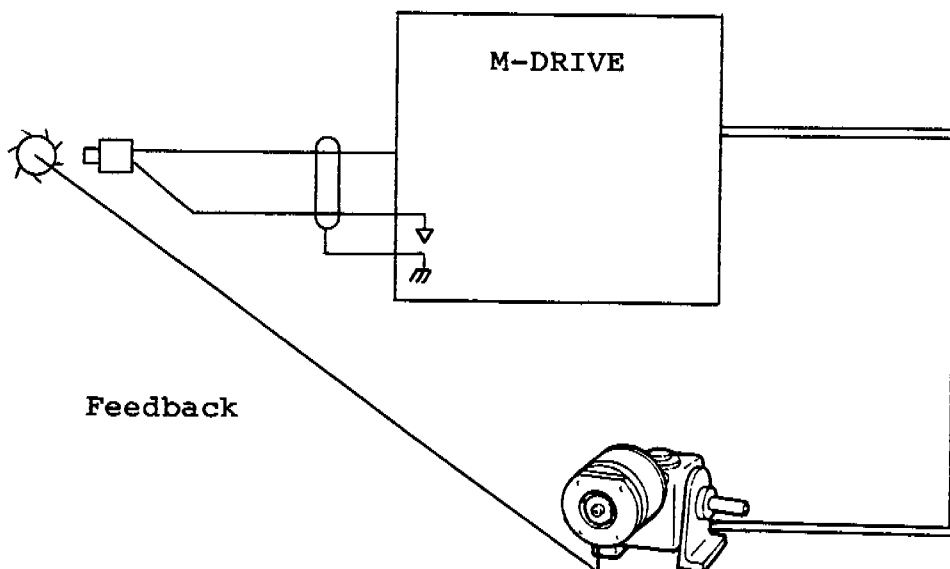

Figure 1-2: Simplified Functional Diagram

M-DRIVE FORMATS

INTRODUCTION

Selecting an M-Drive Format determines the type of speed control used by the M-Drive. There are four different formats, two of which are explained below. The remaining two formats are discussed in Chapter 8.

MASTER FORMAT

Master Format is the most straight forward closed-loop implementation of the M-Drive. In Master Format, the setpoint value is entered by the operator via the front keypad. The M-Drive compares this setpoint to the actual motor speed (provided by the motor feedback) to determine the error or deviation. The control algorithm then adjusts the drive output to reduce the error to zero. When shipped from the factory, the M-Drive is in Master Format whenever J4 Pin 3 is not shorted to common.

Detailed examples of using Master Format are provided in Chapter 5 of this manual (Programming).

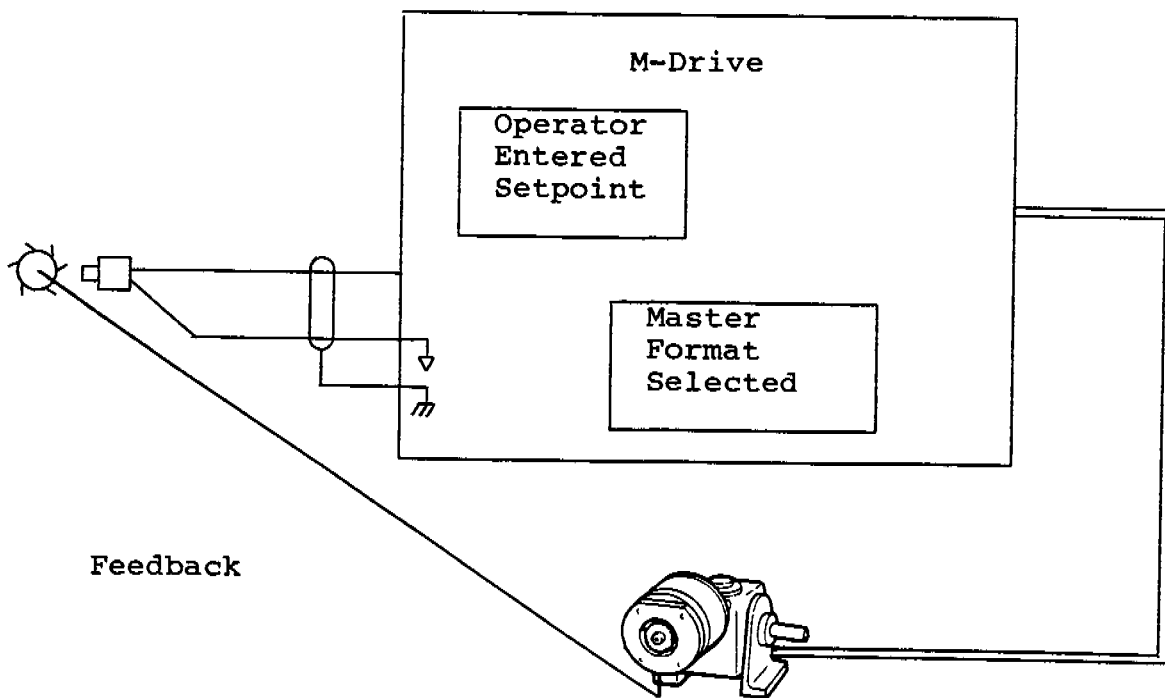

Figure 1-3: Master Format Functional Diagram

FOLLOWER FORMAT

Follower Format is the most commonly used speed control format, and differs from the Master Format in the manner in which the speed command is determined. In Master, the speed command is entered directly by the operator. In Follower, the speed command is directly proportional to both the External Reference Frequency (typically provided by a sensor and gear driven by a motor upstream in the process) and the Ratio Setpoint. Explicitly, if either the Ratio Setpoint or the External Reference Frequency is reduced by half, the Speed Command is reduced by half. If both the Ratio Setpoint and the External Reference Frequency are reduced by half, the Speed Command is reduced to one quarter of its value before the change.

When shipped from the factory, the M-Drive is in Follower Format whenever J4 Pin 3 is shorted to common. Other than the Speed Command determination, both Master and Follower Formats operate the same.

Detailed examples of using Follower Format are provided in Chapter 5 of this manual (Programming).

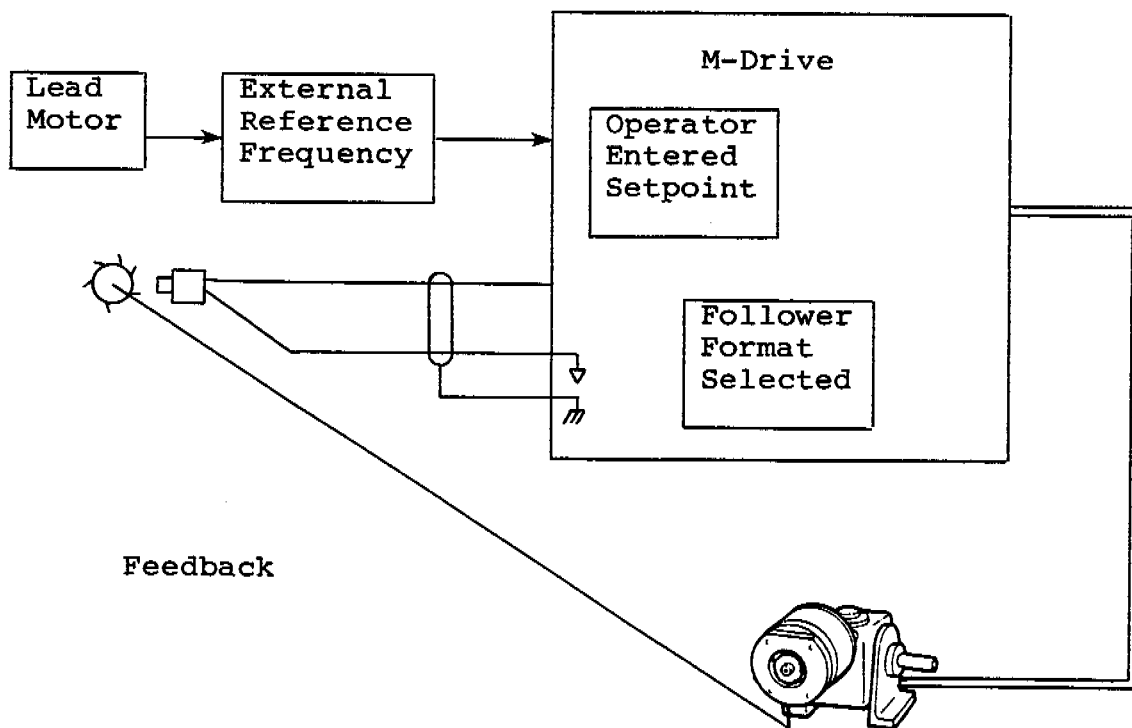

Figure 1-4: Follower Format Functional Diagram

M-DRIVE STATES

The M-Drive States refer to the operation characteristics of the M-Drive--e.g., is the M-Drive running? There are only four operating states for the M-Drive: RUN, R-STOP, F-STOP and JOG. The M-Drive is always in one and only one of these four operating states.

RUN

In the RUN state, the M-Drive rotates the subject motor at the RPM called for by the relevant setpoints in conjunction with the operative scaling format. When speed changes are called for, the M-Drive causes the speed to change according to the specified Accel/Decel rates. Note that RUN can be entered only from R-STOP (not directly from JOG).

Four conditions must be true to put the M-Drive into the RUN State:

- o Short J3 pin 14 to common (Disables F-STOP)
- o Short J3 pin 11 to common (Disables R-STOP)
- o Ensure J3 pin 16 is not connected (Disables JOG)
- o Short J3 pin 13 to common (Initiates RUN)

Note: If the above conditions are all met, there would still be a zero drive output until a non-zero setpoint is entered. If in Follower Mode, a non-zero external reference is also required.

JOG

In the JOG state, the M-Drive increases the speed of the subject motor (using the specified ACCEL rate) until the subject motor is rotating at the RPM entered for the Jog Setpoint.

Four conditions must be true to put the M-Drive into the JOG State:

- o Short J3 pin 14 to common (Disables F-STOP)
- o Short J3 pin 11 to common (Disables R-STOP)
- o Short J3 pin 16 to common (Initiates JOG)
- o Ensure J3 pin 13 is not connected (Disables RUN)

When the JOG state is terminated, the M-Drive ignores the DECEL rate and brings the drive output immediately to zero. In this manner, the operator can "jog" the motor into position.

Note that JOG can be entered only from R-Stop (not directly from RUN).

R-STOP (RAMP STOP)

In the R-STOP state, the M-Drive decreases the drive output to zero using the specified DECEL rate.

Two conditions must be true to put the M-Drive into the R-STOP State:

- o Short J3 pin 14 to common (Disables F-STOP)
- o Ensure J3 pin 11 is not connected (Enables R-STOP)

Note: See Ramp Disable discussion on Page 3-13 concerning an R-STOP exception.

F-STOP (FAST STOP)

In the F-STOP state, the M-Drive ignores the specified DECEL rate and immediately brings the drive output to zero.

One condition must be true to put the M-Drive into the F-STOP State:

- o Ensure J3 pin 14 is not connected (Enables F-STOP)

RUN/STOP LOGIC

The RUN/STOP/JOG state is determined by four logic inputs at J3 pins 14, 11, 13 and 16. Pins 14 and 11 control the F-Stop and R-Stop conditions respectively and both must be shorted to common to allow the M-Drive to enter the Jog or Run States. Specifically, if pin 14 is open the M-Drive is in the F-Stop state regardless of the state of the other pins. If pin 14 is held low while pin 11 is open, the M-Drive is in the R-Stop State.

Pins 13 and 16 control Run and Jog respectively. If pins 14 and 11 are held low, a momentary closure of pin 13 puts the M-Drive in the Run state. Alternatively, if pins 14 and 11 are held low and pin 16 is shorted to common, the M-Drive is put in the Jog State.

Recall that the M-Drive cannot be taken from Jog to Run or from Run to Jog directly. Also note that to enter RUN a momentary closure is sufficient but that the JOG state is invoked only while the closure of J3 pin 16 to common is maintained. Figure 1-7 summarizes the pin status for these 4 Operation States.

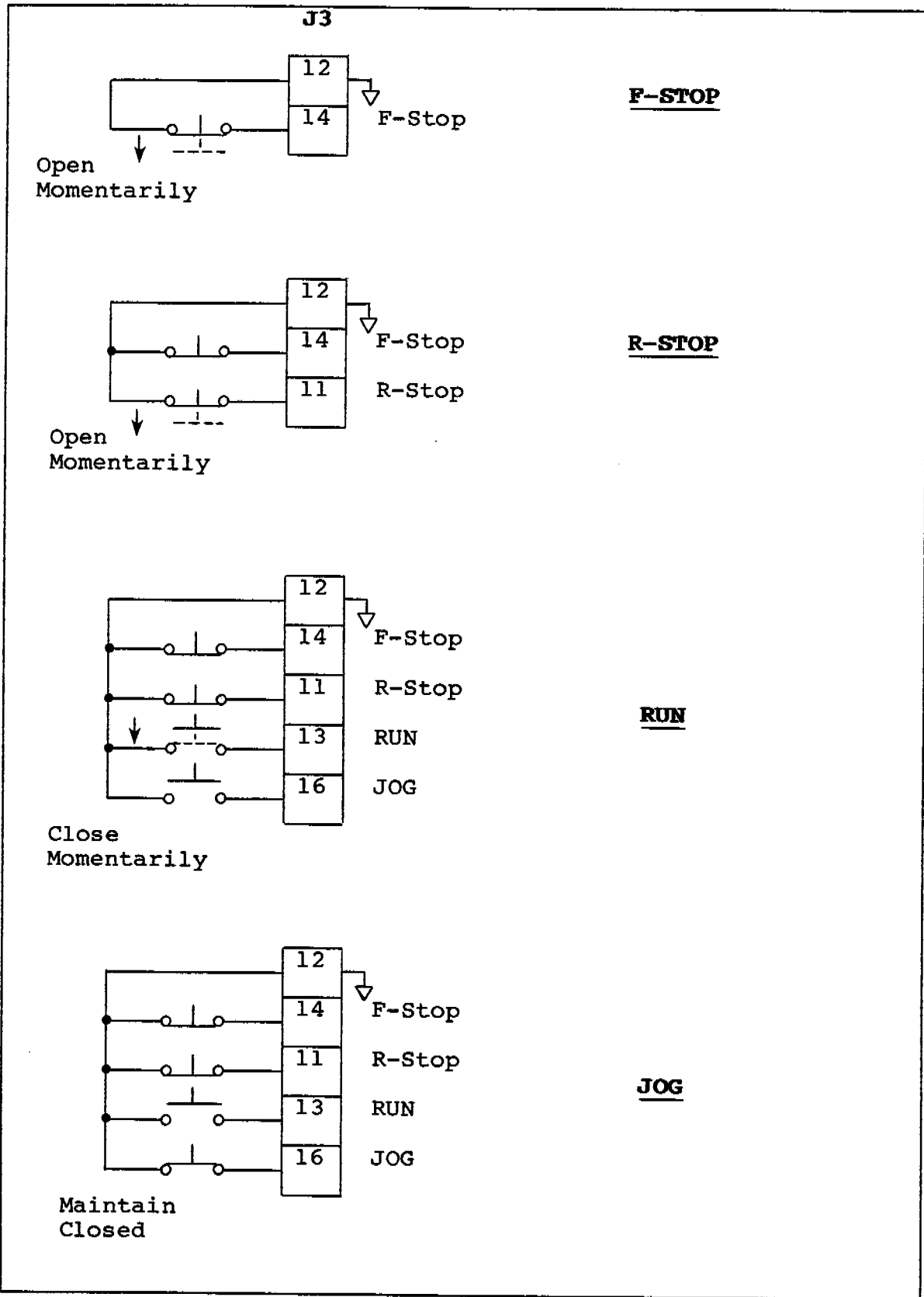

Figure 1-7: Run/Stop Logic

POWER UP

When power is first applied to the M-Drive, the Microprocessor performs self-diagnostic tests approximately 2 seconds in duration. When these tests are finished, the M-Drive enters into a default "STOP" state. Some features of this default state are:

- o The Drive Output is equal to zero.
- o All Programming parameters and setpoints that were entered before power was removed were stored in memory, and are recovered on Power Up.

OPERATOR KEYPAD

The Operator Keypad refers to the upper section of the front M-Drive keypad that is exposed with the lower front door closed. Figure 1-8 illustrates the Operator Keypad.

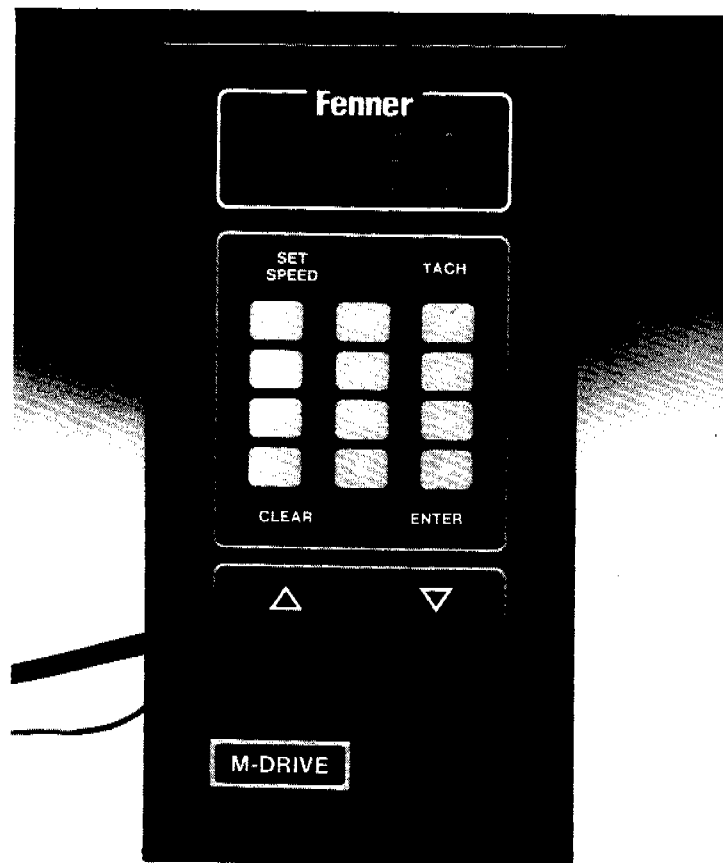

Figure 1-8: Operator Keypad

There are two function keys on the Operator Keypad: Set Speed and Tach. The Set Speed key is used to enable the M-Drive for entry or monitoring of the setpoint (if in Master Mode) or the ratio (if in Follower Mode). (The Master/Follower Mode is determined by the state of the Primary/Secondary control input--J4 pin 3.) The setpoint selection process is described in detail in the Control Inputs section of this chapter.

After the Set Speed key is pressed, the numeric portion of the Operator Keypad is enabled for setpoint entry. The operator enters the setpoint or ratio in scaled engineering units. The M-Drive accepts the new parameter when the Enter key is pressed. Errors made during the entry process can be erased with the Clear Key. The decimal point location is pre-determined by the M-Drive through the scaling parameter entry procedure and need not be entered by the operator.

An alternative to the Set Speed and Numeric entry procedure for changing the Setpoint or ratio involves the use of the scroll keys. The Up and Down scroll keys are always enabled for changing the active setpoint or ratio. (One Exception: Keypad Lockout may disable selected setpoints. See Keypad Lockout discussion under Elective Inputs section of the Installation chapter.) The active setpoint will be altered regardless of which parameter is being displayed on the Operator Keypad. The scroll keys are slow scroll only and are intended for fine adjustments to the setpoint.

The second function key on the Operator Keypad is the Tach key. When pressed the display will indicate the feedback or the ratio of feedback to external reference in engineering units. This feedback display is averaged and updated every one second.

FACTORY DEFAULT SCALING

When shipped from the factory, the M-Drive is scaled for the following settings:

- Lead Motor: 60 tooth gears
 2000 RPM maximum speed

- Slave Motor: 60 tooth gears
 2000 RPM maximum speed

- Master Format: Speed setpoint and Tach are scaled in RPM.

- Follower Format: Ratio Setpoint is scaled so that a 1.000 setting causes the slave motor to rotate at the same RPM as the lead motor.
 Tach is scaled to indicate 1.000 when the RPM of the slave motor is equal to the RPM of the master motor.

Although the default scaling listed above may not be the final scaling used for your application, it is recommended that the system be first started using these default parameters. This facilitates ease of start up tasks when verifying details such as wiring and logic.

For details concerning rescaling the M-Drive, refer to the Programming chapter in this manual.

INTRODUCTION

This chapter contains the information required to hardware configure the M-Drive for purposes of electrical compatibility. The procedures within this chapter should be completed prior to installing the M-Drive. Note that these procedures do not require power to complete.

Before proceeding with the configuration procedure, read the information below to determine if the factory default configuration is appropriate for your application. In most cases, it will not be necessary to reconfigure the M-Drive.

This chapter is divided into 3 sections: Frequency Inputs, Analog Input/Output (Optional), and Power Voltage Select. Figure 2-1 below illustrates the location for the CPU board and the Power Drive board.

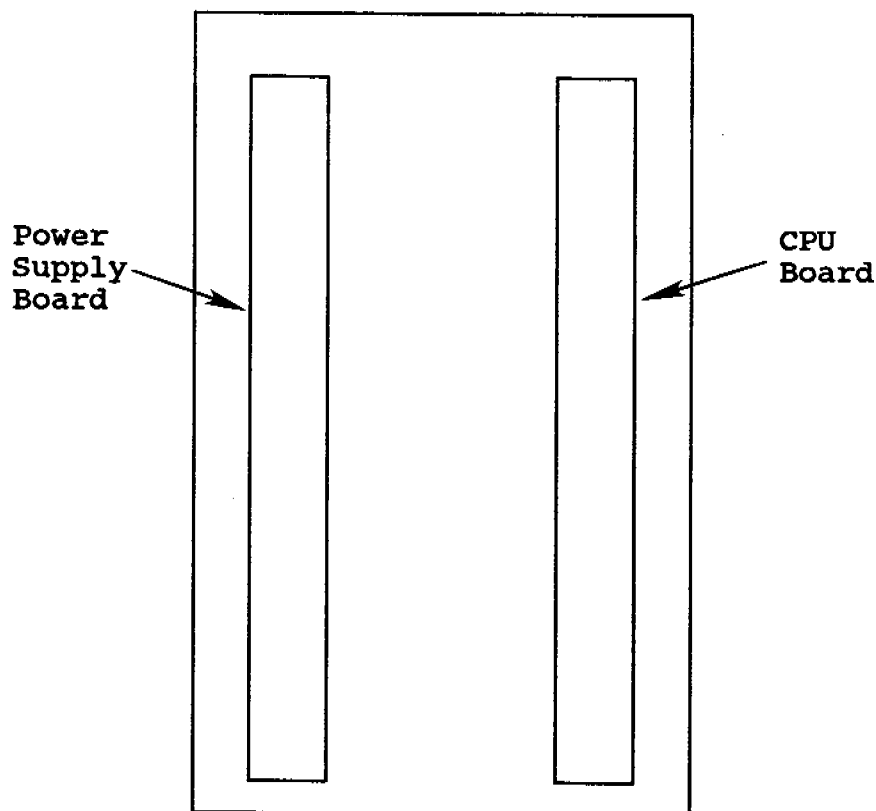

Figure 2-1: M-Drive Board Location (Rear View)

FREQUENCY INPUTS

The Frequency Input select jumpers are located on the M-Drive CPU board. To gain access to this board, remove (pull off) the screw headers from the rear terminal connectors. Next, remove the six mounting screws and backplate. The CPU board is the right-hand board when viewing the M-Drive from the rear (Figure 2-1). Pull this board out approximately 1 inch to expose the Frequency Input select jumpers on the top component side of the board.

Note: Ensure that the CPU board is properly seated into the back pin connections when reassembling the M-Drive.

The Frequency Input select jumper configures the External Reference, Feedback and Auxiliary Frequency Inputs for either zero crossing (magnetic pickup) or open-collector (proximity and encoder) signal compatibility. Table 2-1 below illustrates which jumpers are used to configure these three inputs. For example, a jumper shunted between pins 7 and 8 configures the Feedback Input for Zero Crossing.

	Open Collector	Zero Crossing (Default)
External Reference	1 - 2	3 - 4
Feedback	5 - 6	7 - 8
Auxiliary Input	9 - 10	11 - 12

Table 2-1: Frequency Input Selections

Figure 2-2 below illustrates 2 possible configurations for the Frequency Input select jumpers: Figure 2-2a illustrates all three inputs configured for Open-Collectors, while Figure 2-2b illustrates all three inputs configured for Zero Crossing (Default).

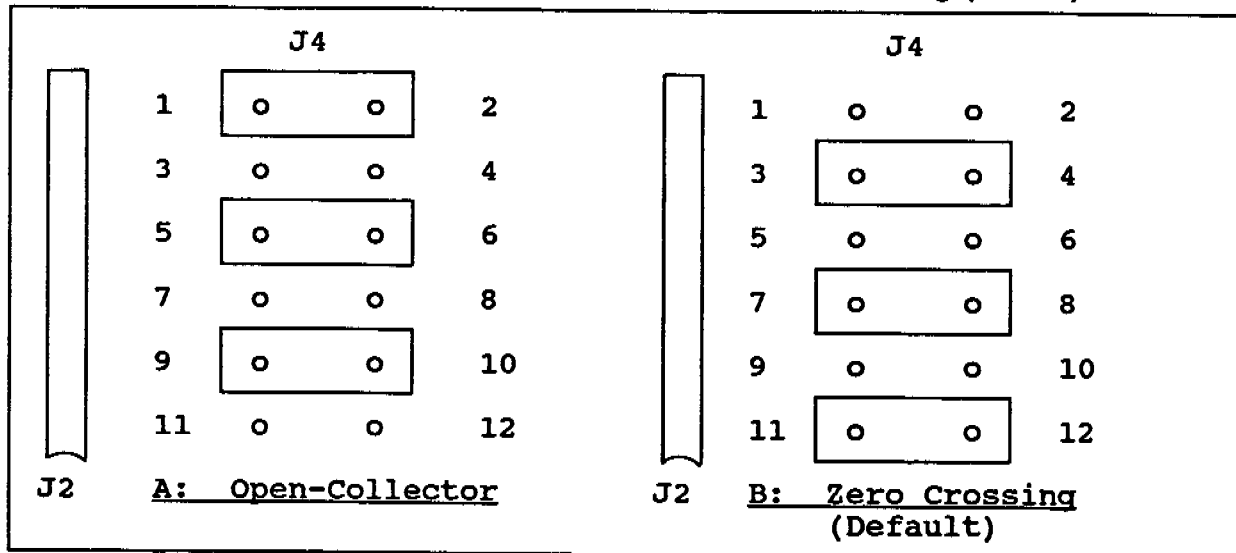

Figure 2-2: Frequency Input Options

ANALOG INPUT/OUTPUT (OPTIONAL)

The Analog Input/Output Option board mounts on the lower rear component side of the CPU board. To field install this option board, first remove the screw barrier connectors on the rear of the M-Drive. Next, remove the six mounting screws and backplate. The CPU board is the right-hand board when viewing the M-Drive from the rear (Figure 2-1). Pull this board out to expose the two 12-position male connectors used to mount the Analog Input/Output Option board (lower rear component side of CPU board). Plug the two 12-position female connectors on the solder side of the Analog Input/Output Option board into the male connectors of the CPU board. A nylon standoff is provided for mechanically mounting the option board. The option board should be mounted with the selector shunts facing the rear of the CPU board.

Note: Ensure that the CPU board is properly seated into the back pin connections when reassembling the M-Drive.

The Analog Input/Output select jumper configures the analog input and output for either a 10 volt DC level or a 4 to 20 mA current level. Table 2-2 below illustrates which jumpers are used to configure the input and output. For example, a jumper shunted between pins 9 and 10 configures the analog output for ± 10 VDC. *

	0 to 10 VDC (Default)	4 to 20 mA
Analog Input	1 - 2 and 5 - 6	3 - 4 and 7 - 8
Analog Output	9 - 10 *	11 - 12

Table 2-2 Analog Input/Output Selections

*** Note:** The analog output level will range from -10 volts to +10 volts when patched to variables with positive and negative values. It will range from 0 to +10 volts for variables with positive values only.

Figure 2-3 below illustrates 2 possible configurations for the Analog Input/Output select jumpers. Figure 2-3a illustrates both the input and output configured for 0-10 VDC (default). Figure 2-3b illustrates both the input and output configured for 4-20 mA.

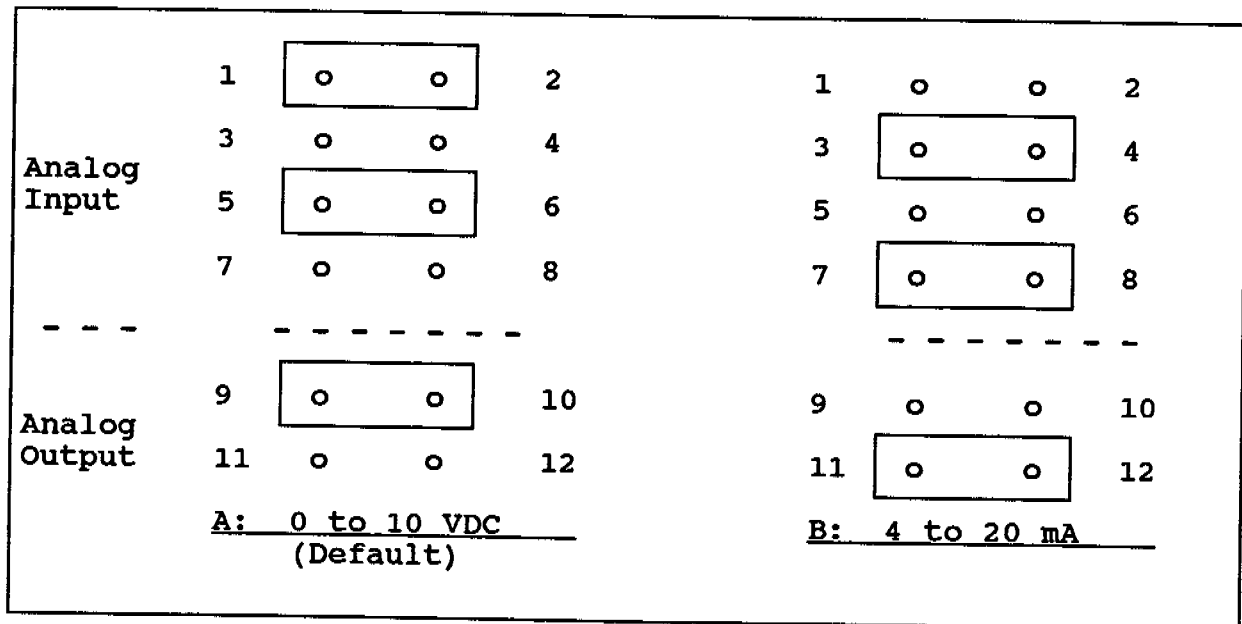

Figure 2-3: Analog Input/Output Options

CAUTION

To prevent possible equipment damage, the upper two shunts configuring the Analog Input must always move as a pair. That is, the Analog Input shunts must connect either positions 1-2 and 5-6 or connect positions 3-4 and 7-8.

POWER VOLTAGE SELECT

The Power Voltage Select switch is located on the bottom of the Power Drive board, just above the fuse.

This switch selects for either 115 VAC (Default) or 230 VAC power.

The switch is clearly marked for the two available positions.

INTRODUCTION

This chapter contains the information and procedures required to complete the initial installation and wiring for the M-Drive. All pages within this chapter must be read to ensure that the appropriate decisions are made prior to the final wiring of the M-Drive.

Note to Electricians installing the M-Drive:

- Class G branch circuit fuses rated 250V, 15 A shall be provided in the end application.
- Motor overload protection shall be provided in the end installation in accordance with the NEC.

The installation of this motor control must conform to area and local electrical codes. For information, refer to the National Electrical Code (NEC) Article 430 published by the National Fire Protection Association, or the Canadian Electrical Code (CEC). Refer to local codes as applicable.

WARNING

Hazardous voltages are present during certain installation procedures. Therefore, the M-Drive should only be installed by qualified electrical maintenance personnel.

This chapter is organized into 2 distinct sections:

MOUNTING

WIRING

The Mounting section provides drawings and instructions for mounting the M-Drive in an enclosure. The wiring section summarizes the wiring connections for the M-Drive.

MOUNTING

INTRODUCTION

The M-Drive is packaged in a 1/2 DIN Vertical instrument enclosure intended for door mounting in a NEMA enclosure. Figure 3-1 illustrates an installed M-Drive with dimensions.

Note: Prior to mounting the M-Drive in your enclosure, complete the Configuration Procedures outlined in Chapter 2. The configuration shunts and switches may be less accessible after the device is installed in the enclosure.

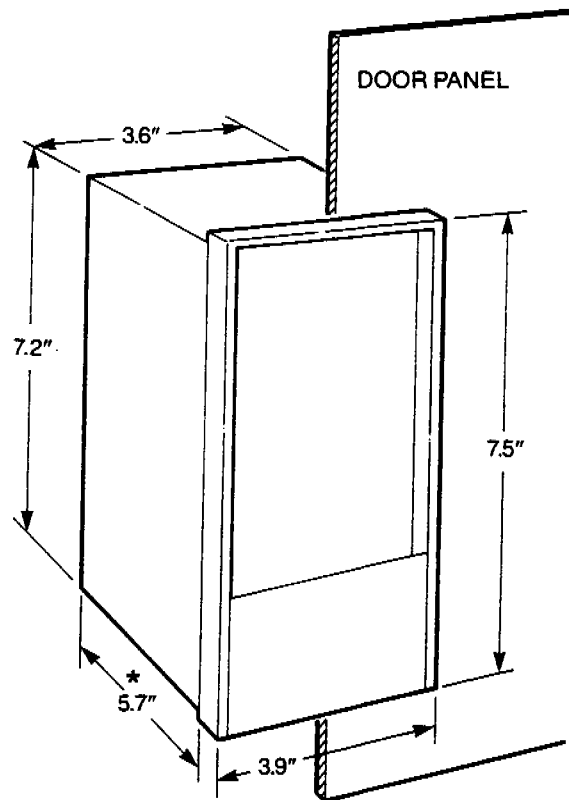

* To rear of Connectors from Front Panel

Figure 3-1: M-Drive Dimensions

MOUNTING PROCEDURE

Mount the M-Drive into your enclosure according to the following procedure:

1. Ensure the mounting location meets the environmental conditions for the M-Drive:

Temperature: 0-55 degrees C (interior enclosure)
Humidity: 0-90% non-condensing

Note: Allow adequate spacing between the M-Drive and other equipment to provide for proper heat convection. Placing the M-Drive too close to adjacent equipment could cause the interior ambient temperature to exceed 55 degrees C. Spacing requirements depend on air flow, enclosure construction and applied horsepower.

2. Determine the appropriate door or panel location and make the panel cutout per Figure 3-2 below. Allow adequate top and bottom room for mounting bracket.
3. Insert the M-Drive from the panel front up to the bezel or gasket.
4. Connect the two mounting brackets from the rear of the M-Drive on the top and bottom.
5. Drive the mounting bracket screws onto the rear of the door or panel until the M-Drive is securely mounted.

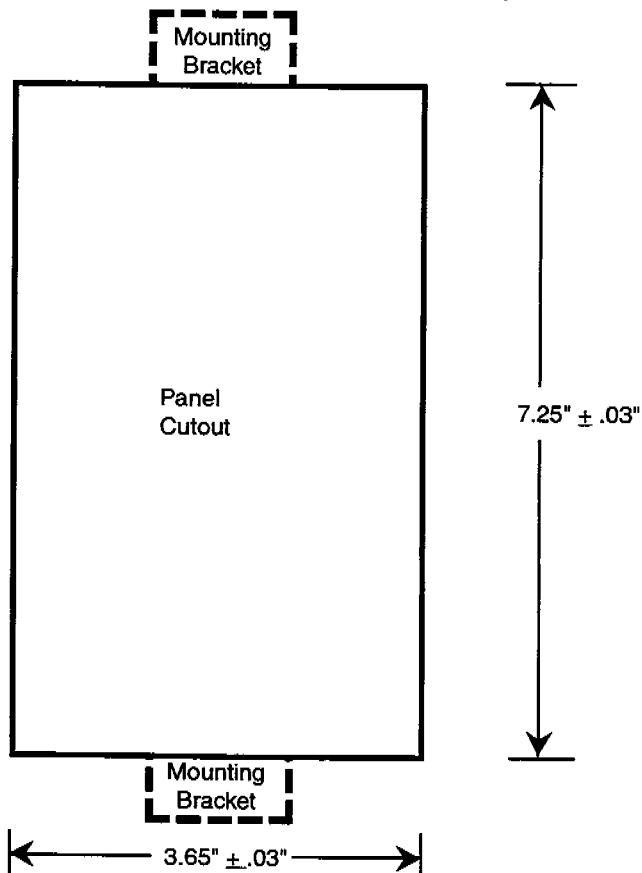

Figure 3-2: Panel Cutout Dimensions

WIRING

INTRODUCTION

The wiring portion of this chapter is divided into five sections:

1. Required Inputs
2. Required Outputs
3. Elective Inputs
4. Elective Outputs
5. Serial Communications

As the titles indicate, the decisions made during the Required sections are mandatory to obtain a properly installed M-Drive. The elective sections are completed at the discretion of the User.

The Serial Communications connections are discussed as a separate item in the fifth and final wiring section.

CAUTION

Where indicated, it is important to use shielded cable to minimize equipment malfunctions due to electrical noise. It is assumed throughout this manual that shields are terminated at the receiving end only.

Proper earth grounding of all electronic equipment is required for successful operation. It is recommended that all shield and chassis ground connections be made to an earth ground to provide proper noise immunity and grounding protection.

AC power wiring (J2) should be kept physically separated from other wiring on the M-Trim. Failure to do so could result in coupled electrical noise and subsequent M-Trim malfunction.

Inductive coils from relay, contactors, solenoids, etc. on the same AC power line or in the same enclosure should be suppressed with an RC network across the coil. Best results occur with resistance (r) values of 50 ohms and capacitance (c) values of 0.1 microfarads.

If excessive EMI noise exists on the AC power line, such as line notches or spikes, it may be required to install an AC line filter or isolation transformer to ensure proper operation.

M-DRIVE WIRING DRAWING

Figure 3-3 below illustrates the control installation wiring for the M-Drive. It is divided into Required Inputs and Outputs, Elective Inputs and Outputs and Serial Communications.

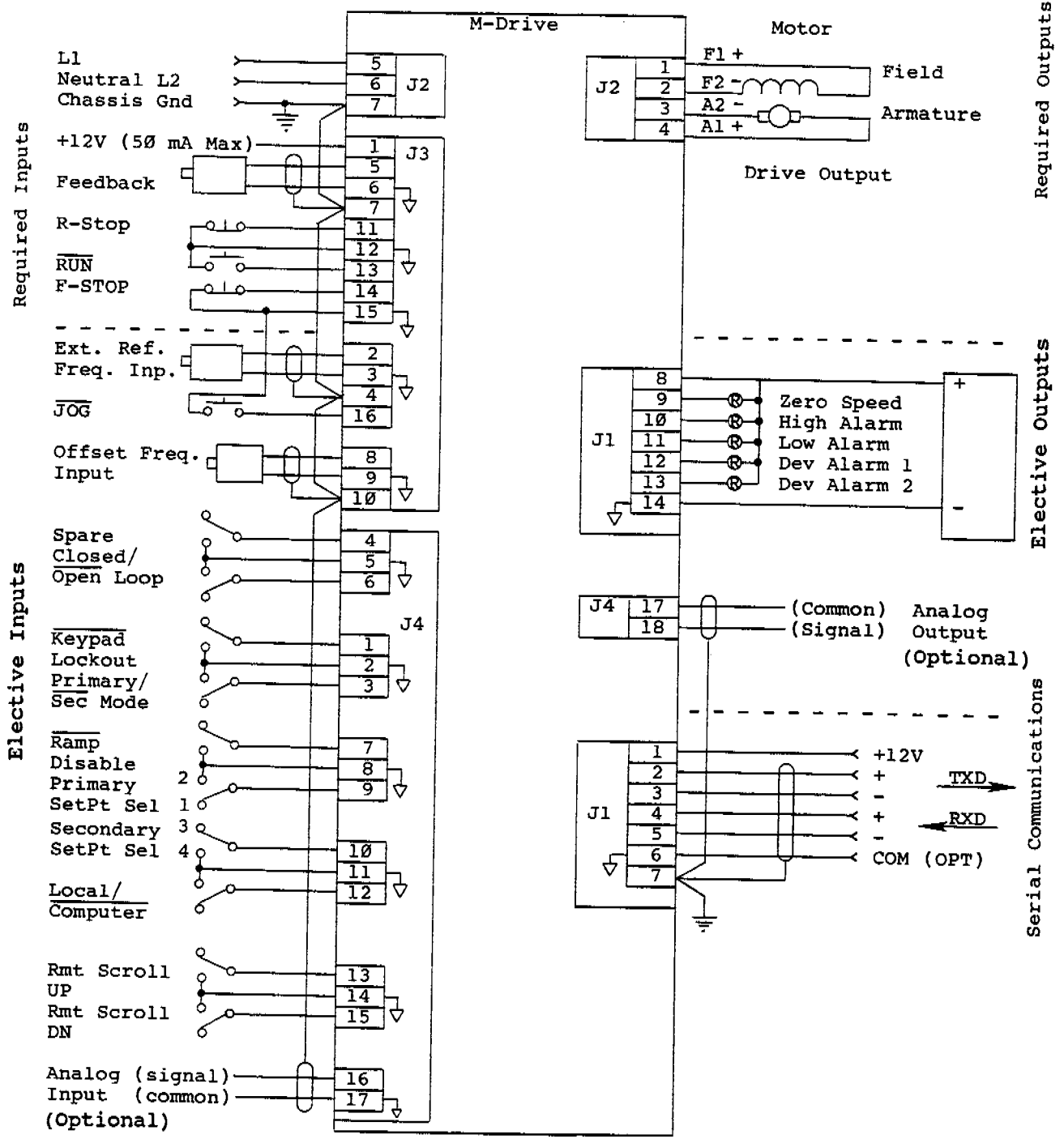

Figure 3-3: M-Drive General Wiring Drawing

3

M-DRIVE CONNECTOR LOCATIONS

Figure 3-4 below illustrates the location and numbering of the wiring connectors as viewed from the rear of the M-Drive.

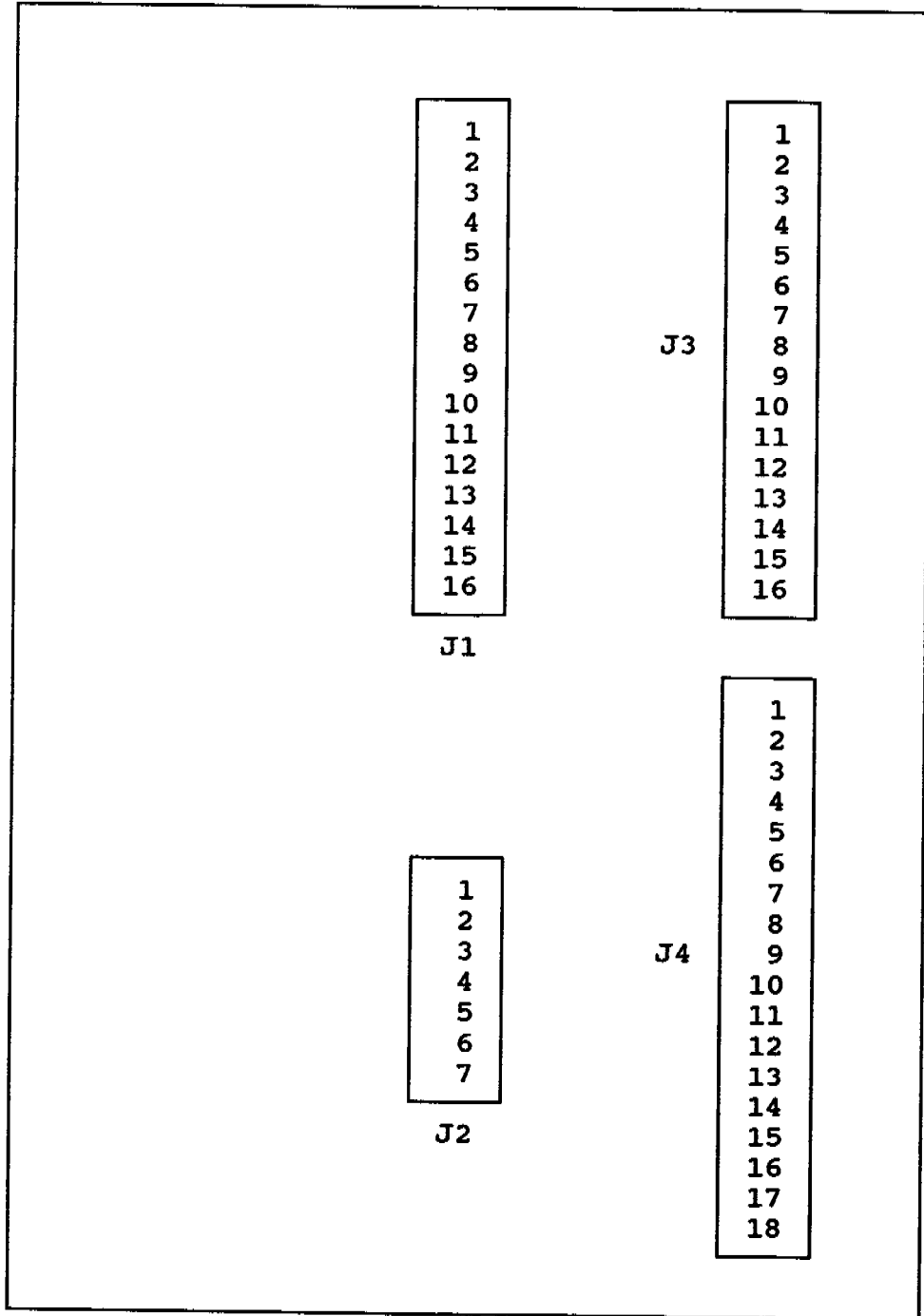

Figure 3-4: Wiring Connector Locations

1) REQUIRED INPUTS

INPUT POWER

The M-Drive operates on either 115 VAC or 230 VAC. The lowest 3 pin connections on J2 are allocated for the power connection.

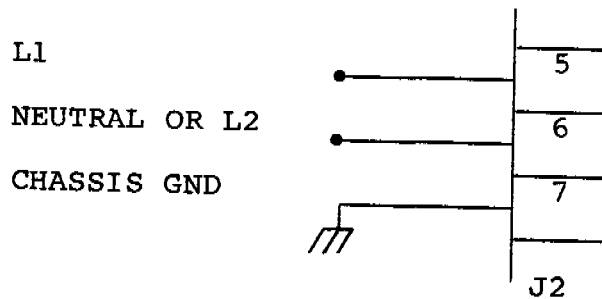

Figure 3-5: Input Power

FEEDBACK INPUT

Feedback Input is a pulse train input used by the M-Drive to ascertain motor speed.

The specific Feedback Input connections to the M-Drive are identical whether the sensor is a Magnetic Pickup, Encoder, Hall Effect Quad Sensor or Proximity Sensor. The Feedback Input connections are illustrated below:

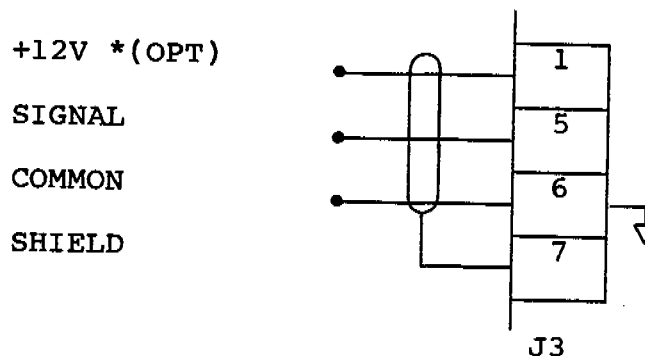

Figure 3-6: Feedback Input Connections

- * Amplified or 3-wire sensors will contain their own source supply voltage or use the M-Drive +12VDC if their current draw does not exceed 50 milliamps total.

RUN

RUN is a momentary input which when closed allows the M-Drive to run normally. As a momentary input, the RUN state is internally latched and need not be maintained by the operator device.

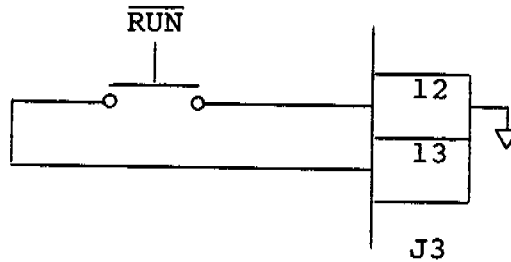

Figure 3-7: Run Input

R-STOP

R-STOP is a momentary input which when opened commands the M-Drive to ramp to zero speed at the specified deceleration rate. As a momentary input, the R-STOP state is internally latched and need not be maintained by the operator device.

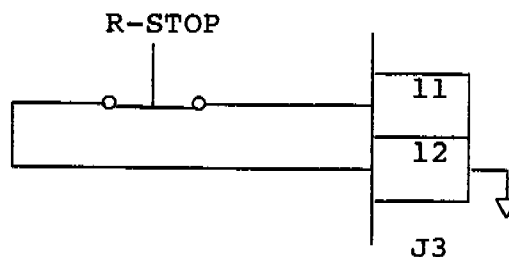

Figure 3-8: R-Stop Input

F-STOP

F-STOP is a momentary input which when opened commands the M-Drive to come to zero speed immediately, ignoring the specified deceleration rate. As a momentary input, the F-STOP state is internally latched and need not be maintained by the operator device.

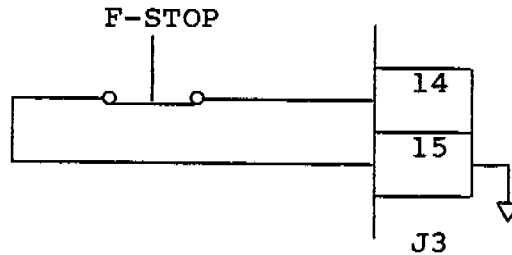

Figure 3-9: F-Stop Input

Note: Both the R-STOP and F-STOP inputs must be closed prior to entering the RUN state. If only one of the Stop inputs is used, the other needs to be wire shorted for proper M-Drive operation.

2) REQUIRED OUTPUTS

MOTOR CONNECTIONS

Connect the armature leads to J2 pins 3 and 4. Reversal of the armature leads reverses the direction of motor rotation.

Connect the field leads to J2 pins 1 and 2. Permanent magnet (PM) motors do not require field connections. Figure 3-10 below illustrates the motor connections.

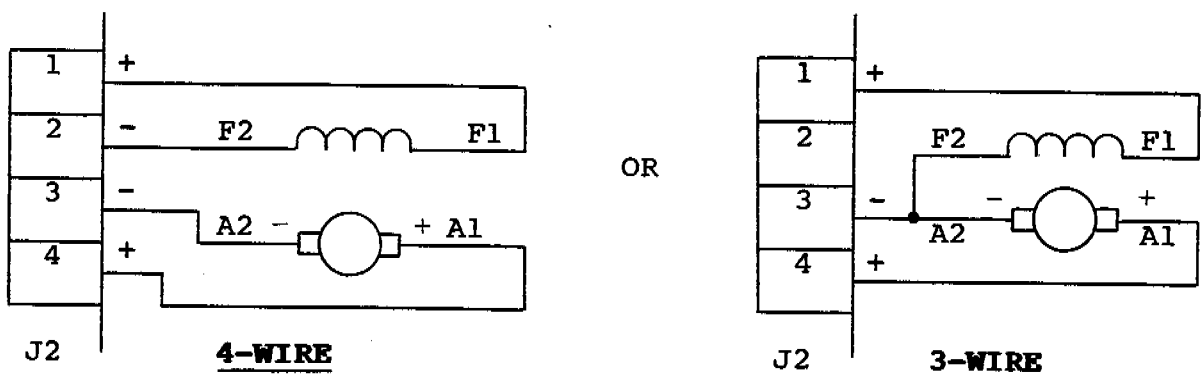

Figure 3-10: Motor Connections

3) ELECTIVE INPUTS

EXTERNAL REFERENCE FREQUENCY INPUT

The External Reference Frequency Input is a frequency input that acts as the lead signal when the M-Drive is in Follower Format. This signal is proportioned by the ratio setpoint to control the speed of the Follower M-Drive.

If this input is used, install per Figure 3-11.

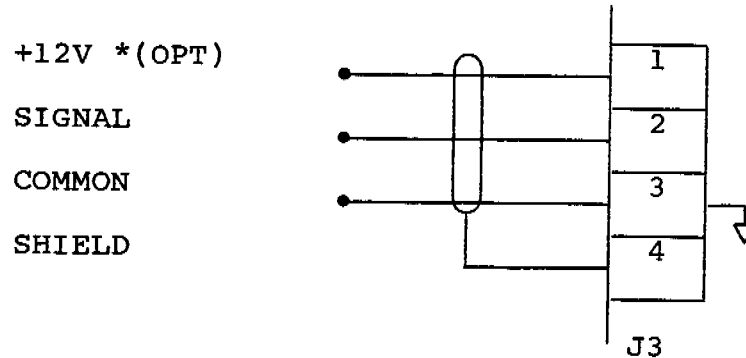

Figure 3-11: External Reference Frequency Input

JOG

JOG is a maintained input which when closed drives the motor at the selected jog speed. As a maintained input, the jog state is only valid for the duration of the time the operator device is held closed.

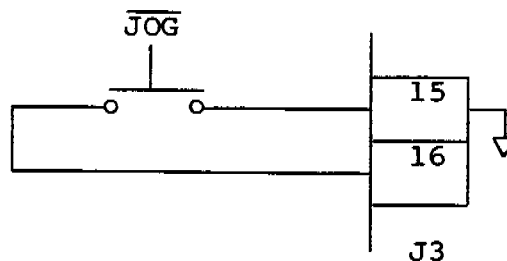

Figure 3-12: Jog Input

CLOSED/OPEN LOOP

The Closed/Open loop input determines the basic manner in which the control algorithm operates. In the Closed Loop position, the control algorithm adjusts the Drive output to reduce the error (setpoint minus feedback) to zero. In the Open Loop position, the control algorithm adjusts the drive output in response to setpoint input only and ignores the feedback or error.

Normal operation of the M-Drive occurs in the Closed Loop position. The Open Loop position is used to calibrate the drive during the scaling operation or to monitor non-linearities in the system control loop.

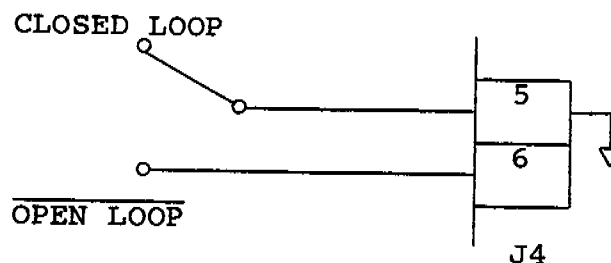

Figure 3-13: Closed/Open Loop Input

PRIMARY/SECONDARY MODE (MASTER/FOLLOWER)

The Primary/Secondary input selects the scaling format used by the control algorithm. The Primary and Secondary modes are user programmable (as described in Chapter 8), but are defaulted to Master and Follower, respectively, as shipped from the factory. A detailed discussion of the scaling modes can be found in the Programming chapters of this manual.

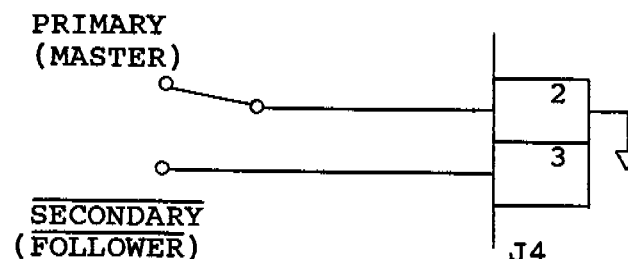

Figure 3-14: Primary/Secondary Input

SETPOINT SELECT

PRIMARY SETPOINT SELECT (SETPOINT #1 OR SETPOINT #2)

The Primary Setpoint Select input selects the setpoint source when in the Primary scaling mode. In the open position, the setpoint is selected from the Control Parameter 1 entered by the operator. In the closed position, the setpoint is selected from the Control Parameter 2 entered by the operator. A more detailed discussion of the selectable setpoint feature is available in the Advanced Programming chapter of this manual.

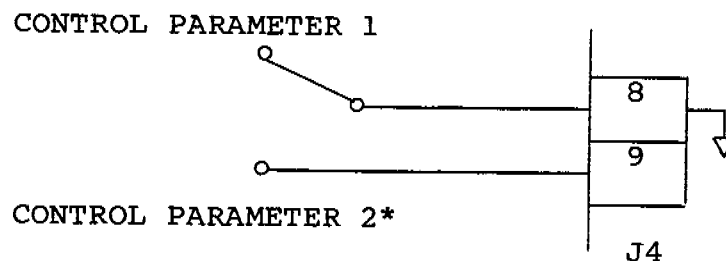

Figure 3-15: Primary Setpoint Select

SECONDARY SETPOINT SELECT (SETPOINT #3 OR SETPOINT #4)

The Secondary Setpoint Select input selects the setpoint source when in the secondary scaling mode. In the open position, the setpoint is selected from the Control Parameter 3 entered by the operator. In the closed position, the setpoint is selected from the Control Parameter 4 entered by the operator. A more detailed discussion of the selectable setpoint feature is available in the Advanced Programming chapter of this manual.

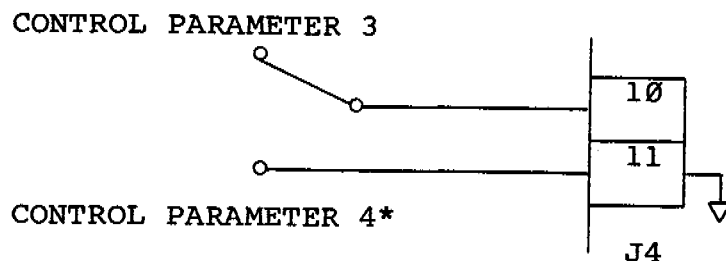

Figure 3-16: Secondary Setpoint Select

RAMP DISABLE

The Ramp Disable input is used to inhibit acceleration or deceleration. Acceleration ramp and deceleration ramp are locked in place until the Ramp Disable input is released.

The only exception to the Ramp Disable function is the F-Stop state. If an F-Stop is called for, the speed drive output is immediately reduced to zero, ignoring the Ramp Disable input.

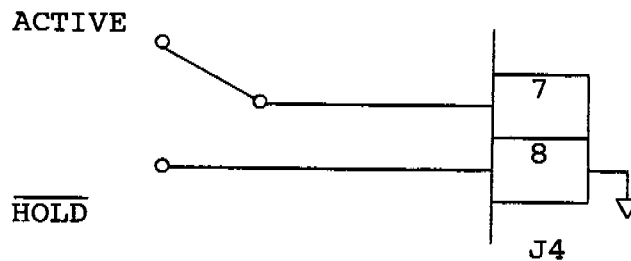

Figure 3-17: Ramp Disable

KEYPAD LOCKOUT

The Keypad Lockout input is used to disable the front operator keypad from making setpoint and other parameter changes. The specific setpoints "locked out" during a Keypad Lockout condition are determined by the Setpoint Mask value (CP-79). See Page C-14 for information concerning Setpoint Mask.

All functions associated with monitoring or viewing of variables remain enabled during Keypad Lockout.

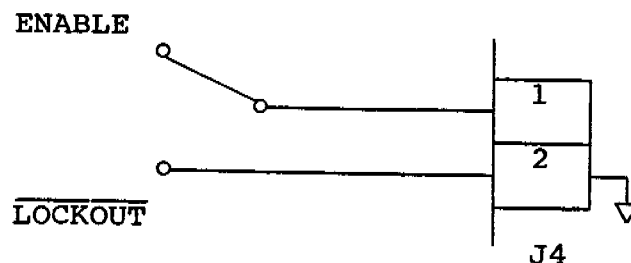

Figure 3-18: Keypad Lockout

LOCAL/COMPUTER

The Local/Computer input is used to enable the serial communications interface to change control variables or selected control commands. In either position, the serial communications is active to monitor variables, but only in the closed position can the serial communications change the control and command variables. More detail on the communications interface is available in Chapter 8 of this manual.

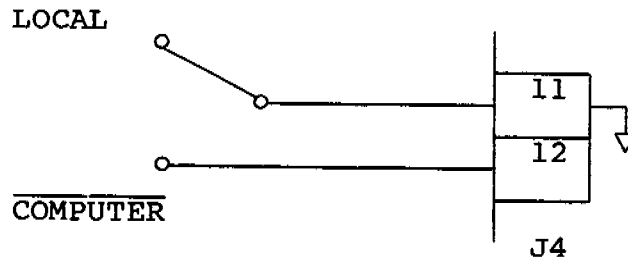

Figure 3-19: Local/Computer Input

REMOTE SCROLL UP

The Remote Scroll Up input increments the active setpoint (see Setpoint Select on Page 3-12 for setpoint selection information). This input increments the active setpoint whether or not the setpoint is displayed.

There are two methods to increment the active setpoint using Remote Scroll Up. Each closure of this input increments the active setpoint 1 Engineering Unit. In addition, the active setpoint increments 1 Engineering Unit every half second while this input is held closed.

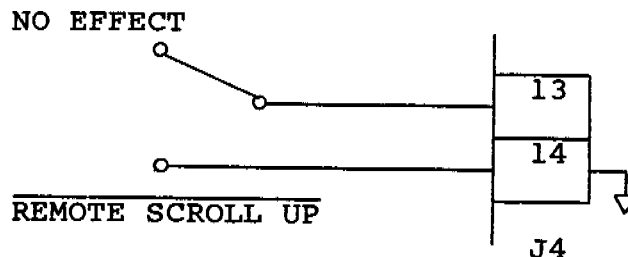

Figure 3-20: Remote Scroll Up

REMOTE SCROLL DOWN

The Remote Scroll Down input decrements the active setpoint (see Setpoint Select on Page 3-12 for setpoint selection information). This input decrements the active setpoint whether or not the setpoint is displayed.

There are two methods to decrement the active setpoint using Remote Scroll Down. Each closure of this input decrements the active setpoint 1 Engineering Unit. In addition, the active setpoint decrements 1 Engineering Unit every half second while this input is held closed.

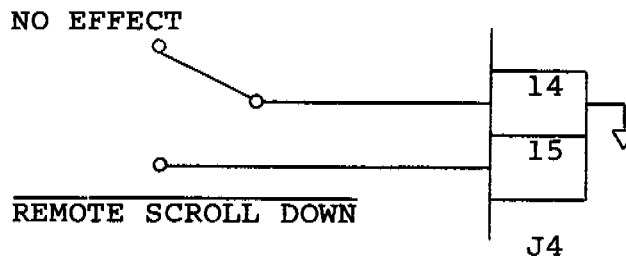

Figure 3-21: Remote Scroll Down

ANALOG INPUT (Requires Optional Analog I/O Board)

The Analog Input can be used to replace either one of the three frequency inputs or one of the four internal setpoint inputs. (For a detailed discussion concerning analog input uses, refer to Chapter 8 - Advanced Programming.) Figure 3-22 below illustrates the wiring for the analog input.

Note: The Analog Input can accept either a 0 to 10 VDC or 4 to 20 mA current source. Refer to Chapter 2 - Configuration, for the Analog Input configuration procedure.

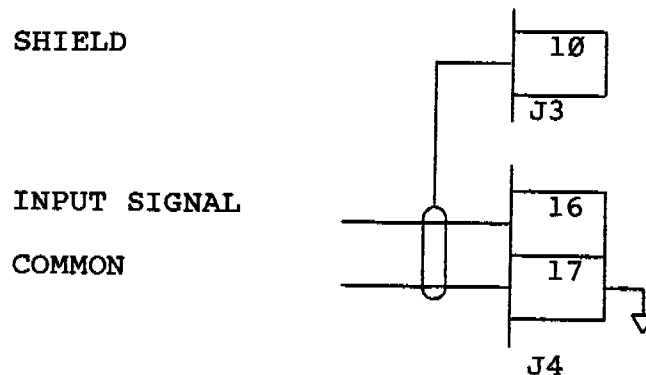

Figure 3-22: Analog Input

4) ELECTIVE OUTPUTS

CONTROL OUTPUTS

The M-Drive Control Outputs are all open-collector relay drivers (specs listed on Page viii). An external DC power supply is required to provide power to the relays. Free-wheeling diodes are incorporated and need not be added externally.

Figure 3-23 illustrates the wiring for the first three elective outputs. The remaining outputs follow the same pattern.

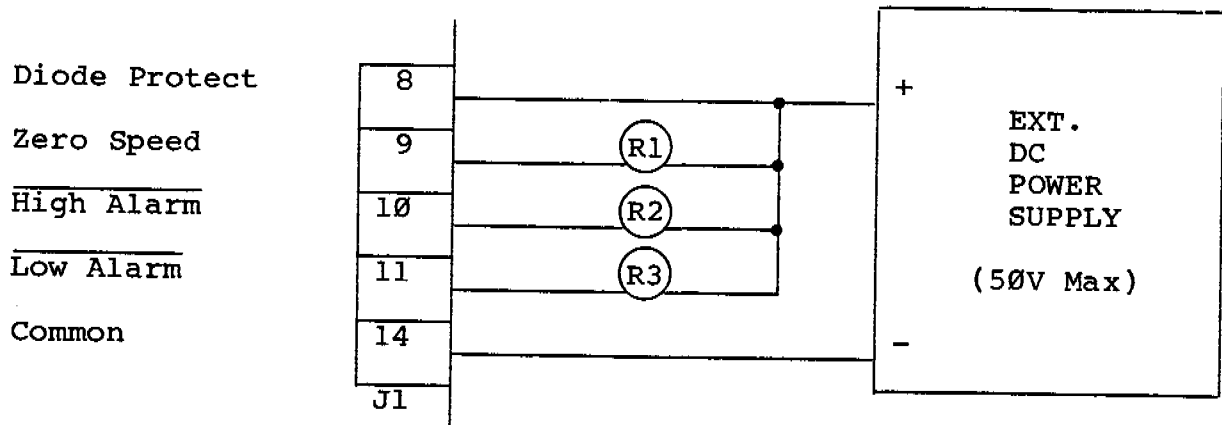

Figure 3-23: Elective Outputs

ZERO SPEED (J1 Pin 9)

The Zero Speed output may be controlled either by the Ramped Reference, or by both the Ramped Reference and the Feedback. For additional information, refer to CP-74 on Page C-13.

HIGH ALARM (J1 Pin 10)

The High Alarm output is used to indicate when the speed, as identified by the Feedback Input, exceeds a level that is specified by the operator. The High Alarm output is high (inactive) when the feedback is below this level. It is low (active) when the feedback is at or above this level. (See CP-13 on Page C-3.)

LOW ALARM (J1 Pin 11)

The Low Alarm output is used to indicate when the feedback is below a level that is specified by the operator. The Low Alarm output is high (inactive) when the feedback is above this level. It is low (active) when the feedback is at or below the specified level. (See CP-12 on Page C-3.)

RAMPED ERROR (ERROR ALARM 1) (J1 Pin 12)

The Ramped Error output is used to indicate when the speed error (Ramped Reference minus feedback) is at or outside a band specified by the operator. This output is high (inactive) when the error is within the specified band. It is low (active) when the error is at or exceeds the specified band. (See CP-14 on Page C-3.)

SCALED ERROR (ERROR ALARM 2) (J1 Pin 13)

The Scaled Error output operates the same as the Ramped Error, except the speed error is: (Scaled Reference minus feedback). (See CP-15 on Page C-3.)

ANALOG OUTPUT (Requires Optional Analog I/O Board)

The Analog Output can be patched to any of the monitor variables or control parameters of the M-Drive. (For a detailed discussion concerning analog output uses, refer to Chapter 8 - Advanced Programming.) Figure 3-24 below illustrates the wiring for the analog output.

Note: The Analog Output can be configured for either a ± 10 VDC or 4 to 20 mA level. Refer to Chapter 2 - Configuration, for the analog output configuration procedure.

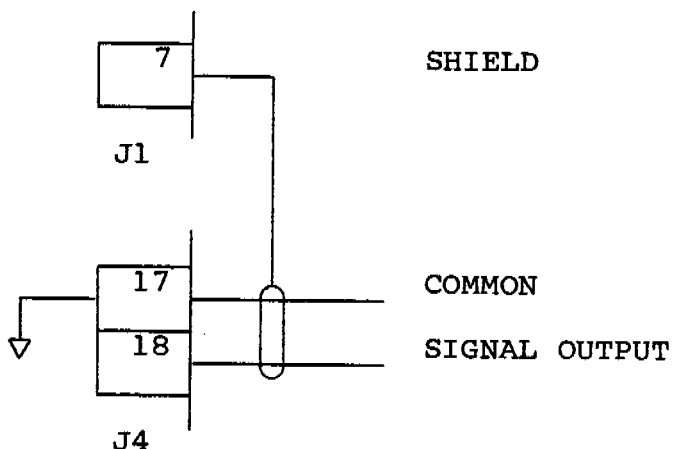

Figure 3-24: Analog Output

5) SERIAL COMMUNICATIONS

The Serial Communications interface on the M-Drive complies with EIA Standard RS-422 -A for balanced line transmissions. This interface is provided to permit remote computer variable programming, status or performance monitoring, and remote control. A detailed discussion of the Serial Communications capability is provided in Chapter 7 of this manual.

Figures 3-25 and 3-26 illustrate a multidrop installation of the Serial Communications link.

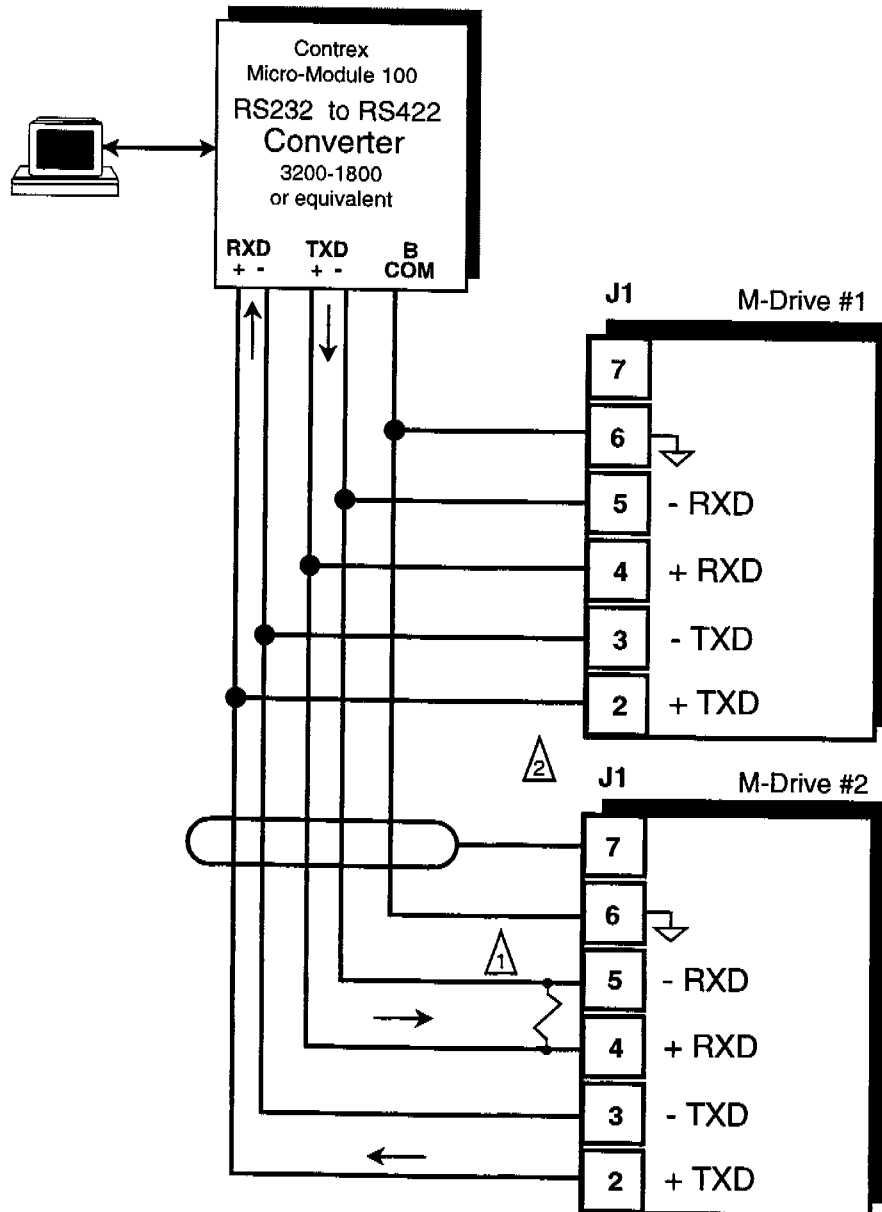

Figure 3-25: Serial Communications Connections

1

It may be necessary to terminate the communication line at the furthest receiving ends only. A 100 ohm, 1/2 Watt resistor is usually adequate for this purpose. For more information, refer to EIA Standard RS-422-A.

2

Shield at one end of cable only.

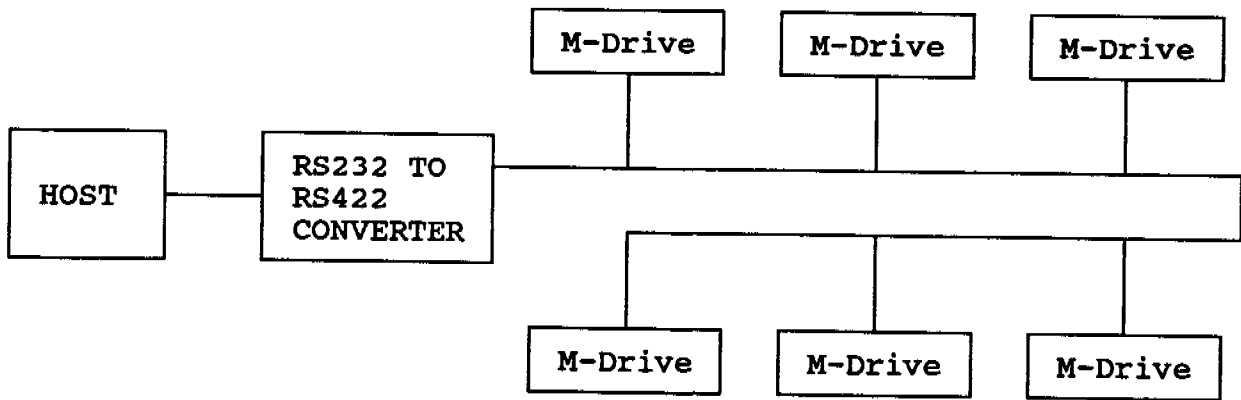

Figure 3-27: Correct M-Drive Multidrop Installation

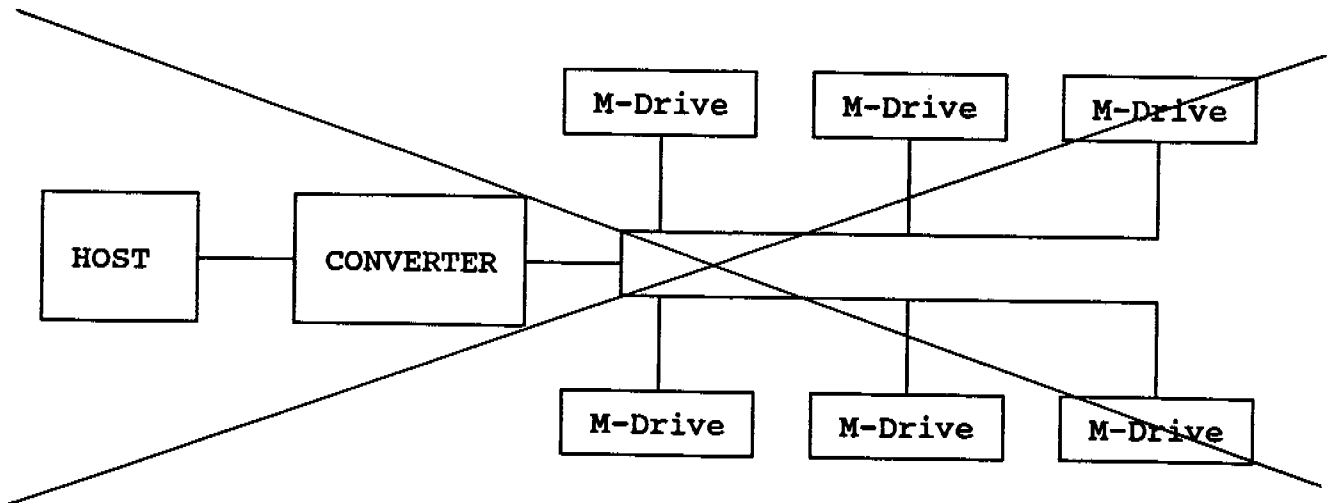

Figure 3-28 Incorrect Installation

INTRODUCTION

This chapter contains the information required to calibrate the current limit and analog input/output of the M-Drive. Prior to using these procedures, the M-Drive must be properly configured and installed in accordance with Chapters 2 and 3 of this Manual.

CURRENT LIMIT

The current limit level on the M-Drive is adjustable from approximately 4 to 15 amps. To limit the load current to the desired limit, follow the procedure below:

1. Place a DC plus AC RMS ammeter in series (or clamp on) with one of the motor armature lines (A1 or A2).
2. Turn the current limit potentiometer at the rear of the M-Drive fully clockwise. This potentiometer is located below the J1 connector.
3. With the M-Drive in the RUN state, gradually increase the load until the AC ammeter reaches the desired limit level.
4. Turn the current limit potentiometer counterclockwise until the M-Drive begins to current limit. This is exhibited by the following conditions:
 - a) A slight reduction in motor RPM
 - b) The front panel "Limit Alarm" LED illuminates
 - c) CP-52 indicates a value of 7.
5. Increase the motor load gradually. The load current should not increase and the motor RPMs should decrease.

The rate at which the M-Drive reduces motor RPMs in response to added load in current limit is adjustable. This value is defaulted at the factory and should not require field adjustment. However, if a different value is desired, adjust CP-60 until the desired response is achieved.

Note: The current limit is not operable when the M-Drive is in Direct Scaling Mode (CP-61 = 0). For additional information concerning Direct Scaling Mode, refer to Chapter 8 (Advanced Programming).

ANALOG INPUT (Requires Optional Analog I/O Board)

The analog input is factory calibrated for zero and span levels at 0-10 VDC. If it is necessary to field calibrate the analog input, follow these procedures:

Zero Adjust

1. Enter CP-85 by pressing: Code Select, 8, 5, and "Enter"
2. Place either zero volts (short) or 4 mA on the analog input depending on the analog input configuration (determined during Chapter 2 procedures).
3. Press the "." (decimal point) key. The display should now read between 0 and 20. This step zero adjusts the analog input.

Span Adjust

1. Enter CP-86 by pressing: Code Select, 8, 6, and "Enter".
2. Place either +10 VDC or 20 mA on the analog input depending on the analog input configuration (determined during Chapter 2 procedures).
3. Press the "." (decimal point) key. The display should now display a value from 3600 to 4000 for a 10 VDC input. This step span adjusts the analog input.

For a comprehensive discussion of the functional use of the analog input for replacing frequency inputs and setpoints, refer to Chapter 8, Advanced Programming.

ANALOG OUTPUT

(Requires Optional Analog I/O Board)

Zero Adjust

The Analog Output is factory calibrated for zero and span levels at ± 10 VDC. If it is necessary to field calibrate the analog output, follow these procedures:

1. Place a DC voltmeter or ammeter on J4 pins 17 and 18. (Use a DC voltmeter if the analog output is configured for ± 10 VDC, or use an ammeter if the analog output is configured for 4 to 20 mA.)
2. Enter CP-82 by pressing: Code Select, 8, 2, and "Enter".
3. Enter new values for CP-82 until the output on the meter reads zero or 4 mA. (See NOTE below.) Enter values from 0 to 2048 (a value of 1024 is nominal). Larger values will increase the analog output level. The analog output is now zero adjusted.

Note: Two methods are available for entering new values into the M-Drive:

- 1) Press the digit keys until the new number is displayed, then press "Enter".
- 2) Press the scroll keys until the new number is displayed.

Span Adjust

1. Enter CP-83 by pressing: Code Select, 8, 3, and Enter.
2. Enter new values for CP-83 until the meter reads 10 volts or 20 mA. Enter values from 2048 to 4096. Larger values will increase the analog output level. The analog output is now span adjusted.

A comprehensive discussion of the functional use of the analog output is available in Chapter 8, Advanced Programming.

NOTES

INTRODUCTION

This section of the manual explains the use of the code select procedure for changing and viewing the M-Drive's Programming Codes. All Programming Codes can be divided into two broad categories: Control Parameters (indicated by a "CP-") and Monitor Variables (indicated by a "MV-". Programming or Scaling the M-Drive is accomplished by entering relevant values into the M-Drive's Control Parameters to influence the control behavior of the M-Drive. Monitor variables are display variables used to view or monitor the systems performance during M-Drive operation.

This chapter is divided into six sections:

Code Select Procedure explains the use of the programmer keypad for gaining entry to the Control Parameters and Monitor Variables.

Modes and Formats explains how the Modes and Formats operate in an M-Drive.

Setpoint Selection and Control explains how the setpoints are used in an M-Drive.

Examples provides 5 application examples using the M-Drive.

Tuning provides procedures to fine-tune the M-Drive.

Phase Control provides procedures which allow Follower Scaling Mode to reduce the long-term speed error to zero.

CODE SELECT PROCEDURE

The Code Select Procedure indicates how the operator gains access to the various control and monitor parameters through their unique identification codes. Opening the lower door on the front of the M-Drive keypad exposes the programming keypad.

Accessing the desired parameter is a simple procedure:

- 1) Press the Code Select Key.
- 2) Enter the desired parameter code number.
- 3) Press the Enter Key.

At this point, the two digit Programming Code is displayed in the lower display window and the existing parameter value is displayed in the upper four digit display window. In addition, the keypad is enabled for changing the desired parameter (if applicable). To make a change, simply enter the new value and press the Enter Key.

Note: If the Enter Key is not pressed within approximately ten seconds of a new value being entered, the display reverts to the previous value.

The Programming Codes can be grouped in the following categories:

<u>Programming Codes</u>	<u>Category</u>
CP-01 to CP-06, CP-79	Setpoint Control
CP-10 to CP-15, CP-74	Alarms and Limits
CP-16, CP-17	Acceleration and Deceleration
CP-18, CP-19, CP-29	Phase Control
CP-20 to CP-23, CP-30 to CP-38	Scaling
MV-40 to MV-57	Monitor Variables
CP-60 to CP-64, CP-75 to CP-78	Scaling Format Selection and Control
CP-65 to CP-69	Tuning
CP-70 to CP-73	Serial Communications
CP-80 to CP-86	Analog Input/Output

All other numbers are unused and reserved for expansion. A complete list of all Programming Codes accompanied by a short description is located in Appendix C of this manual.

LED INDICATORS

Next to the M-Drive programming keypad are five LEDs. When on, these LEDs indicate the following:

<u>LED On</u>	<u>Indicates</u>
RUN	M-Drive is in the RUN state
JOG	M-Drive is in the JOG state
Preset	M-Drive is referencing either Setpoint #2 or Setpoint #4
Limit Alarm	One or more of the following alarms or limits is invoked: Low Alarm (CP-12) High Alarm (CP-13) Minimum Speed (CP-10) Maximum Speed (CP-11) Current Limit
Dev Alarm	Either Error Alarm 1 (Ramped Reference Error) or Error Alarm 2 (Scaled Reference Error) or both are invoked.

MODES AND FORMATS

PRIMARY MODE/SECONDARY MODE

At any one time the M-Drive has two complete scaling programs available. In this manual these programs are referred to as "Formats". As initially programmed, these formats are "Master" and "Follower", descriptions of which appear below. The Scaling Format that is currently operative is determined by the voltage level at J4 Pin 3. When this pin is at a logic high (not shorted to common), the M-Drive is in Primary Mode and the Master Scaling Format is invoked. Alternatively, when the pin is at a logic low (shorted to common), the M-Drive is in Secondary Mode and the Follower Scaling Format is invoked.

Although the terms Primary and Secondary appear to be redundant with Master and Follower, this is not the case as other scaling formats exist. (These additional formats are discussed in the Advanced Programming chapter of this manual.) For the purposes of this chapter, Primary and Secondary may be considered synonymous with Master and Follower respectively.

MASTER SCALING FORMAT

The Master Scaling Format is the simplest M-Drive scaling format. The motor speed is controlled only by one variable: the Speed Setpoint. The motor speed is directly proportional to the Speed Setpoint.

Scaling constants allow the programmer to specify the maximum normal operating RPM of the motor and the Speed Setpoint associated with it. The Speed Setpoint scaling is normally chosen to reflect the desired flow rate of product such as gallons/hour, feet/minute or widgets/day. Similarly, the tach displays a number directly proportional to motor speed and is usually scaled to reflect actual flow rate of product as calculated from the Feedback Frequency. Note that the Speed Setpoint and the Tach need not be scaled the same.

This scaling format is called Master because an M-Drive operating under Master Format is often used to control the speed of an entire process line, setting the pace for other M-Drives following the Master at various controlled speed ratios.

Refer to Appendix H for Master Format parameters.

FOLLOWER SCALING FORMAT

The Follower Scaling Format is the most commonly used scaling format. Motor speed is controlled by and is directly proportional to two variables: The Ratio Setpoint and a frequency applied to J3 pin 2. This frequency is referred to as the External Reference Frequency, and it is usually generated by an encoder or gear and magnetic sensor combination mounted on a shaft upstream in the process (See Appendix A). Alternatively, this frequency may be produced by a voltage controlled oscillator (See Page 5-16).

Scaling constants allow the programmer to specify the maximum External Reference Frequency, the maximum Follower Motor RPM and the Ratio Setpoint to be associated with them. The Ratio Setpoint scaling is normally chosen to reflect the desired ratio of the flow of the product controlled by the Follower Motor to that controlled by the Master Motor. Similarly, the Tach displays the ratio of the Follower Motor Speed to the Master Motor Speed or frequency, and is usually (but not necessarily) scaled to reflect the actual ratio between the product flows.

This format is called Follower because the motor follows or is paced by a frequency or the speed of another motor at a ratio entered at the Ratio Setpoint. Refer to Appendix H for Follower Format parameters.

Note that other speed/tach formats and combinations exist other than Master Scaling Format and Follower Scaling Format. Consult the Advanced Programming chapter in this manual for information regarding these possibilities.

SETPPOINT SELECTION AND CONTROL

SINGLE SETPOINT FOR EACH FORMAT

When shipped from the factory, the M-Drive provides a separate individually settable setpoint for each scaling format. That is, one for Primary Mode and one for Secondary Mode. The relevant setpoint is automatically presented in the display when the "Set Speed" key is pressed. To illustrate, assume the M-Drive is being operated under Master Format (Primary Mode), and 1234 has been entered as a setpoint. If the operator presses the "Set Speed" key, 1234 appears in the display. If the M-Drive is then switched to Follower Format (Secondary Mode), a separate setpoint reserved for Follower Format appears in the display. Assume that 1.000 is now entered for the Follower Format Setpoint, and the M-Drive is then returned to Master Format. 1234 would then reappear as the operative setpoint for Master Mode.

Note that the decimal location for the two setpoints is controlled by entries at CP-20 and CP-21, and need not be entered with the setpoint.

TWO SETPOINTS FOR EACH FORMAT

If needed, an alternate setpoint is available for each format (mode) for a total of four possible setpoints. These are identified by the numbers one through four and are accessible via CP-01, CP-02, CP-03 and CP-04. Specifically, setpoints 1 & 2 are associated with Primary Mode (#2 being the alternate or preset), and setpoints 3 & 4 are associated with Secondary Mode (#4 being the alternate or preset).

Although it was not stated, in the "One Setpoint for each Format" section above, Setpoint 1 was used by the Master Format in Primary Mode, and Setpoint 3 was used by the Follower Format in Secondary Mode.

To invoke Setpoint #2 while in Primary Mode, short J4 pin 9 to common. Note that Setpoint #2 is subject to the decimal point control established by the entry at CP-20 as is Setpoint #1.

To invoke Setpoint #4 while in Secondary Mode, short J4 pin 10 to common. Setpoint #4 is also subject to the decimal point control established by the entry at CP-21 as is Setpoint #3.

Table 5-1 illustrates the logic conditions necessary to invoke each setpoint. Recall that shorting J4 pin 3 to common puts the M-Drive into Secondary Mode.

(-- indicates irrelevant)

Setpoint 1	<table border="1"> <tr><td>3</td></tr> <tr><td>9</td></tr> <tr><td>10</td></tr> <tr><td>11</td></tr> </table>	3	9	10	11	Primary/Secondary Mode Primary Setpoint Select Secondary Setpoint Select
3						
9						
10						
11						
	J4					
Setpoint 2	<table border="1"> <tr><td>3</td></tr> <tr><td>9</td></tr> <tr><td>10</td></tr> <tr><td>11</td></tr> </table>	3	9	10	11	Primary/Secondary Mode Primary Setpoint Select Secondary Setpoint Select
3						
9						
10						
11						
	J4					
Setpoint 3	<table border="1"> <tr><td>3</td></tr> <tr><td>9</td></tr> <tr><td>10</td></tr> <tr><td>11</td></tr> </table>	3	9	10	11	Primary/Secondary Mode Primary Setpoint Select Secondary Setpoint Select
3						
9						
10						
11						
	J4					
Setpoint 4	<table border="1"> <tr><td>3</td></tr> <tr><td>9</td></tr> <tr><td>10</td></tr> <tr><td>11</td></tr> </table>	3	9	10	11	Primary/Secondary Mode Primary Setpoint Select Secondary Setpoint Select
3						
9						
10						
11						
	J4					

Table 5-1: Logic Conditions to Invoke Setpoints

MASTER SCALING FORMAT (PRIMARY MODE)

To program the M-Drive's Master Scaling Format, enter the data as indicated below:

<u>Code #</u>	<u>Code Title</u>	<u>Data to be Entered</u>
CP-1 or CP-2	Primary Setpoint	This is the desired setpoint (speed) in Engineering Units.
CP-61	Primary Scaling Format	01
CP-63	Primary Display Format	01
CP-34	Primary RPM Max Feedback	RPM of the feedback sensor shaft when operating at the maximum speed during normal operation.
CP-20	Primary Setpoint Eng Units	This is the number wanted as a setpoint when the feedback shaft is rotating at the RPM entered at CP-34.
CP-31	PPR Feedback	This is the number of teeth on the gear or the number of lines on the encoder used for feedback
CP-22	Primary Display Eng Units	The number desired to be displayed by the tach when the feedback shaft is rotating at the RPM entered at CP-34. This is often but not always the same as the number at CP-20.

MASTER FORMAT, DEFAULT PARAMETERS (PRIMARY MODE)

When shipped from the factory, the following assumptions are made:

The Feedback gear has 60 teeth and is mounted on the Motor armature.

The maximum motor RPM is 2000.

The Speed Setpoint is Scaled in RPM.

The Tach indicates RPM.

Based on these assumptions, the M-Drive's default programming is as follows:

<u>Code #</u>	<u>Code Title</u>	<u>Data to be Entered</u>
CP-61	Primary Scaling Format	01
CP-63	Primary Display Format	01
CP-34	Primary RPM Max Feedback	2000
CP-20	Primary Setpoint Eng Units	2000
CP-31	PPR Feedback	60
CP-22	Primary Display Eng Units	2000

NOTE: If the above assumptions are accurate for your application except that a 30-tooth gear is present, the above settings are accurate except that "30" would be entered at CP-31.

MASTER FORMAT, NON-STANDARD PARAMETERS (PRIMARY MODE)

Example:

A pump delivers 15 gallons/minute when the motor rotates at 1725 RPM.

A 30-tooth gear is present on the motor armature.

Both the Setpoint and the Tach are to indicate gallons per minute.

<u>Code #</u>	<u>Code Title</u>	<u>Data to be Entered</u>
CP-61	Primary Scaling Format	01
CP-63	Primary Display Format	01
CP-34	Primary RPM Max Feedback	1725
CP-20	Primary Setpoint Eng Units	15.00
CP-31	PPR Feedback	30
CP-22	Primary Display Eng Units	15.00

FOLLOWER SCALING FORMAT (SECONDARY MODE)

To program the M-Drive's Follower Scaling Format, enter the data as indicated below:

<u>Code #</u>	<u>Code Title</u>	<u>Data to be Entered</u>
CP-3 or CP-4	Secondary Setpoint	This is the desired setpoint (ratio).
CP-62	Secondary Scaling Format	02
CP-64	Secondary Display Format	02 *
CP-37	Secondary RPM Feedback Maximum	RPM of the feedback sensor shaft when operating at the maximum speed during normal operation.
CP-36	Secondary RPM External Maximum	Maximum RPM during normal Reference operation of the shaft on which the external reference sensor is monitoring.
CP-21	Secondary Setpoint Eng Units	This is the number wanted as a setpoint if the Ext Ref. and feedback shafts are rotating at the speeds entered at codes CP-36 & CP-37 respectively. This number is often but not necessarily 1.000
CP-23	Secondary Display Eng	The number desired to be Units displayed by the Tach when the Ext. Ref. and feedback are rotating at the speeds entered at codes CP-36 & CP-37 respectively.
CP-31	PPR Feedback	This is the number of teeth on the gear or the number of lines on the encoder used for feedback.
CP-30	PPR Ext. Ref.	This is the number of teeth on the gear or the number of lines on the encoder used for external reference.

* If an Engineering Unit (speed) display is desired, set CP-64 to "1."

FOLLOWER FORMAT, DEFAULT PARAMETERS (SECONDARY MODE)

When shipped from the factory, the following assumptions are made:

There are 60 tooth gears on both the Master and Follower Motor armatures.

The maximum motor RPM for both motors is 2000.

The Ratio Setpoint is scaled such that a 1.000 entry causes the Follower Motor to rotate at the same RPM as the Master Motor.

Whenever the RPM of the Follower Motor is equal to the RPM of the Master Motor, the Tach indicates 1.000.

Based on these assumptions, the M-Drive's default programming is as follows:

<u>Code #</u>	<u>Code Title</u>	<u>Data to be Entered</u>
CP-62	Secondary Scaling Format	02
CP-64	Secondary Display Format	02
CP-37	Secondary RPM Feedback Max	2000
CP-36	Secondary RPM External Reference Max	2000
CP-21	Secondary Setpoint Eng Units	1.000
CP-23	Secondary Display Eng. Units	1.000
CP-31	PPR Feedback	60
CP-30	PPR External Reference	60

FOLLOWER FORMAT, NON-STANDARD PARAMETERS (SECONDARY MODE)

Example:

It is desired that the Setpoint and Tach reflect the flow ratio in gallons/minute of B to A.

The Motor/Pump combination used for Component A delivers 10 gallons/minute at 1725 motor RPM.

The Motor/Pump combination used for Component B delivers 30 gallons/minute at 1800 motor RPM.

A 60-tooth gear is used for the Ext. Ref. (Component A).

A 30-tooth gear is used for follower (Component B).

Both gears mount on the motor armature.

Calculations

1. Determine the flow ratio that exists when both components are flowing at maximum rate.

$$\frac{30 \text{ Gal/Min (Component B)}}{10 \text{ Gal/Min (Component A)}} = 3.000$$

<u>Code #</u>	<u>Code Title</u>	<u>Data to be Entered</u>
CP-62	Secondary Scaling Format	02
CP-64	Secondary Display Format	02
CP-37	Secondary RPM Feedback Max	1800
CP-36	Secondary RPM External Reference Max	1725
CP-21	Secondary Setpoint Eng Units	3.000
CP-23	Secondary Display Eng. Units	3.000
CP-31	PPR Feedback	30
CP-30	PPR External Reference	60

TUNING

Tuning refers to the procedure of setting the tuning parameters of the control algorithm to achieve stable and optimal performance. The default tuning parameters should provide for stable operation in the majority of applications. The tuning instructions below are provided for those applications which require additional M-Drive tuning.

TUNING PROCEDURE - SPEED LOOP

65 - GAIN

To set the Gain (Proportional Band), first set the Reset (66) and Rate (67) variable to zero and the Trim Authority (68) to 100. Reduce the Gain number until the system goes unstable (erratic). This is easily tested by moving between two wide spread setpoint values while in Master Scaling Mode. When instability is reached, increase the Gain number slightly until the system stabilizes.

66 - RESET (Integral)

Using only Gain, the system will exhibit a phenomenon called proportional droop, whereby the setpoint is never reached due to system losses. Reset should be added until overshoot is exhibited (move from large numbers to small to increase the reset). Overshoot occurs when the feedback goes over the desired setpoint before settling to the desired setpoint value. It is necessary to switch between setpoints to observe overshoot.

67 - RATE (Derivative)

Rate is only required if the control is still too sluggish after setting the Gain and Reset parameters. Rate, like Gain, should be reduced up to the point of instability, then increased slightly until the system stabilizes.

To reduce Rate, move from larger to smaller numbers. To increase Rate, move from smaller to larger numbers.

68 - TRIM AUTHORITY

Trim Authority determines how much of the output is influenced by the Gain, Reset and Rate terms, and how much is determined by feedforward. If it is not possible to achieve stable operation with 100% Trim Authority, reduce this parameter and repeat the tuning procedure.

69 - RATE THRESHOLD

If erratic operation is exhibited only at very low feedback frequencies, the Rate Threshold can be increased slightly. This parameter determines the minimum amount of differential error required before the Rate term influences the control output.

TIMING

16 - ACCELERATION TIME

This parameter determines the acceleration rate of the setpoint. The number entered is the amount of time in seconds required to increase the setpoint from 0 to 2000 RPMs.

17 - DECELERATION TIME

This number determines the deceleration rate of the setpoint. The number entered is the amount of time in seconds required to decrease the setpoint from 2000 to 0 RPMs.

LIMITS AND ALARMS

The following parameters set up the control limits and alarms for the M-Drive.

10 - MINIMUM LIMIT

This parameter sets the minimum level of RPMs for operation. It is possible to enter a setpoint below this level. However, the control will always attempt to maintain a speed at or above the minimum limit.

11 - MAXIMUM LIMIT

This parameter sets the maximum level of RPMs for operation. It is possible to enter a setpoint above this limit. However, the control will always attempt to maintain a speed at or below the maximum limit.

12 - LOW ALARM

This parameter sets the RPM level at which the Low Alarm output is energized. The output will energize when the feedback RPMs are at or below this level.

13 - HIGH ALARM

This parameter sets the RPM level at which the High Alarm output is energized. The output will energize when the feedback is at or above this RPM level.

14 - ERROR ALARM 1 - RAMPED ERROR

This parameter establishes the error band (Ramped Ref minus Feedback) in RPMs at which the Error Alarm 1 output is energized. Any positive or negative error at or above this level energizes the output.

15 - ERROR ALARM 2 - SCALED ERROR

This parameter establishes the error band (Scaled Ref minus Feedback) in RPMs at which the Error Alarm 2 output is energized. Any positive or negative error at or above this level energizes the output.

NOTE: This alarm is useful for determining when the ultimate process speed has been reached - E.g., after an acceleration period.

PHASE CONTROL

ZERO POSITION ERROR CONTROL

The M-Drive has the ability to reduce the long-term speed error to zero in Follower Scaling Mode. This is done by keeping track of the number of External Reference and Feedback pulses received. The inside speed control loop is then setpoint adjusted to reduce this error to zero.

The M-Drive Zero Error controlling parameters are defaulted to zero. Values for the following three parameters will need to be entered to invoke this feature of the M-Drive. For additional information concerning Zero Position Error Control, refer to Chapter 6, Theory of Operation.

18 - LAG PULSE LIMIT

The Lag Pulse Limit sets a maximum pulse error count for the difference between the idealized Feedback pulses minus the actual Feedback pulses. It may not always be desirable to recover all of the position error lag. Set this parameter to the desired lag pulse limit.

19 - LEAD PULSE LIMIT

The Lead Pulse Limit sets a maximum pulse error count when the Feedback pulses exceed the idealized Feedback pulse count. Set this parameter to the desired lead pulse limit.

29 - RECOVERY MULTIPLIER

The Recovery Multiplier determines the rate at which the pulse error is reduced to zero. This parameter multiplied by the pulse error count is the number by which the speed setpoint is adjusted every 100 milliseconds.

49 - PULSE ERROR COUNT (Monitor Variable)

Indicates the actual existing position error in feedback pulses.

NOTE: When the phase control feature is invoked (CP-29 does not equal zero), the Minimum Limit (CP-10) and Maximum Limit (CP-11) may be exceeded while attempting to recover position error.

FEEDBACK AND EXT. REF. SOURCES OTHER THAN GEAR AND SENSOR

In certain applications, the Feedback and External Reference signals are not generated by gears or encoders. Two examples are voltage controlled oscillators and the clocking oscillators in inverters. The basic rule for making these substitutions is to use 60 for the PPR entry and the maximum frequency for the RPM entry. This works until the frequency exceeds 9999 HZ. For frequencies from 10K to 30K HZ, use 600 for the PPR entry and maximum frequency divided by 10 for the RPM entry.

INTRODUCTION

Figure 6-1 below contains a function block diagram of M-Drive operation. This chapter is organized around this diagram, with a chapter section for each triangle enclosed number.

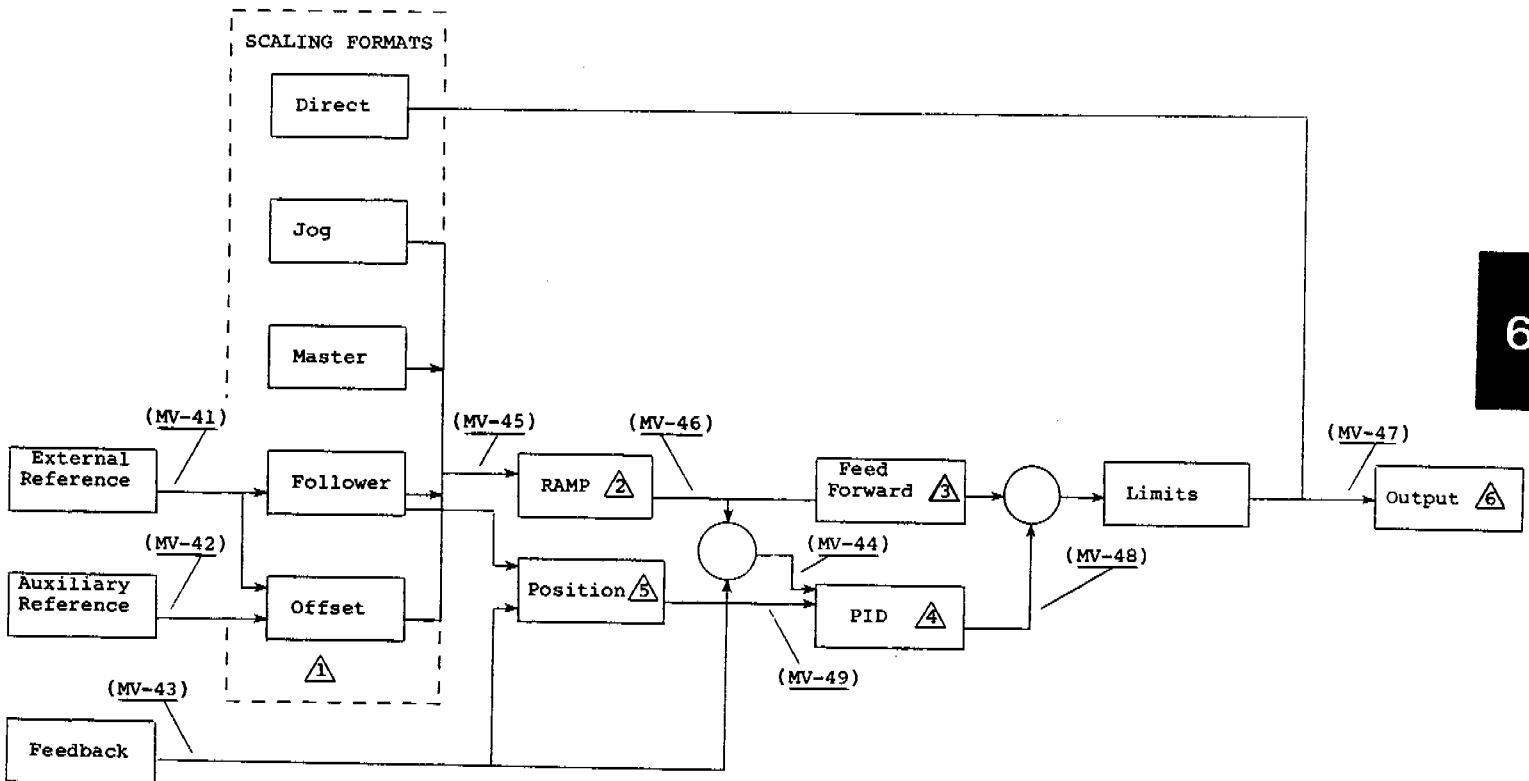

Figure 6-1: M-Drive Operation Function Block Diagram

SCALING 1

When in the "RUN" state, the M-Drive determines the active scaling format and calculates the required speed from the relevant variables such as setpoint, external reference, etc. Internally, this is formulated as the required feedback frequency. It is called the "Scaled Reference", and can be monitored at MV-45. This calculation is not subject to the Accel/Decel ramps and as such represents what the required feedback frequency will be when the Accel/Decel ramps have run their course.

Jogging is no different; however, when using the "Direct" scaling format, this routine is bypassed and "0" appears at MV-45.

RAMP 2

The Ramp routine calculates the ramped reference from the scaled reference. If the scaled reference is constant and the Accel/Decel ramps have run their course, the ramped reference is equal to the scaled reference. However, if the scaled reference changes, then the ramp routine determines (via the entries at CP-16 (Accel) and CP-17 (Decel)) the maximum allowable change in reference during 10 milliseconds:

- o If the new scaled reference is within this limit, it becomes the new ramped reference.
- o If the new reference is outside the limit, then the new ramped reference is taken to be that imposed by the limit.

In addition, the following situations effect RAMP:

1. During R-Stop, the Ramped Reference ramps down at the rate specified by CP-17. The only exception is when Ramp Disable is invoked. Under this condition, the Ramped Reference is frozen.
2. During F-Stop, the Ramped Reference goes immediately to zero irrespective of the specified Decel rate or Ramp Disable.
3. When Jogged, the Ramped Reference increases to the Jog Speed (CP-5) according to the Accel Rate (CP-16). When the Jog State is terminated, the Ramped Reference ignores the specified Decel rate and goes immediately to zero.
4. When the Direct Scaling format is used, the Ramp routine is bypassed and a "0" appears in MV-46 (Ramped Reference).
5. Note that if the position loop is active, it can (under some circumstances) overpower the Ramp Routine. (See Position Loop discussion in this chapter.)

FEED FORWARD 3

The Feed Forward provides an output to the output summing junction as a percent of Ramped Reference. Unlike the PID routine, Feed Forward does not use the error or deviation in its calculations. Instead, Feed Forward is later summed with the PID output to provide the total output.

Feed Forward is used directly as the speed command when the M-Drive is operating Open Loop. When operating Closed Loop, Feed Forward is first adjusted by the PID routine before being applied to the drive output.

THE PID ROUTINE 4

When operating OPEN LOOP, the PID routine is bypassed. When operating Closed Loop, the PID routine generates from the error a correction to the Feed Forward calculation described above. This correction is composed of three parts: Proportional (P), Integral (I), and Differential (D). These components are described below.

PROPORTIONAL

The feedback frequency is subtracted from the Ramped Reference to produce the Proportional error. This value can be observed at MV-44 (Deviation). The Proportional Error is multiplied by a scaling constant and then divided by the quantity at CP-65 (Gain) to derive the proportional term. Thus, smaller entries at CP-65 result in greater responses to proportional errors.

INTEGRAL

The running accumulated total error is the Integrated Error. The Integrated Error is multiplied by a scaling constant and divided by the quantity at CP-66 (Reset) to derive the integral term. As this coefficient is also in the denominator, smaller entries result in faster response.

DIFFERENTIAL

From the most recent value for error, subtract the preceding value. This yields the change in error or the differential error. The result is multiplied by a scaling constant and divided by the entry at CP-67 (Rate) to derive the differential term. As in the case of the other two components, this means that smaller figures in CP-67 have larger consequences.

DIFFERENTIAL THRESHOLD

Because of the inherent sensitivity of the differential factor, its response to such variables as the tooth to tooth angular error of the feedback gear can be objectionable. This can be controlled by requiring the differential error to exceed some threshold before being recognized. This threshold value is entered at CP-69.

TRIM OUTPUT

The three components are then added together to give the net correction to be added to the Feed Forward calculation:

$$\frac{P(f1)}{CP-65} + \frac{I(f2)}{CP-66} + \frac{D(f3)}{CP-67} = \text{Trim Output}$$

(f1, f2 and f3 are constants)

This PID Routine correction is called the "Trim Output", and is a signed number which can be monitored at MV-48.

POSITION LOOP 5

The M-Drive has the ability to maintain zero absolute error indefinitely via the Position Loop routine. The calculations for this technique are beyond the scope of this manual, but operationally it is straightforward and is controlled by the following variables:

- CP-18 (Lag Pulse Limit)
- CP-19 (Lead Pulse Limit)
- CP-29 (Pulse Recovery Multiplier)
- MV-49 (Pulse Error Count -- used to monitor Position Loop results)

The Position Loop feature is usable in the Follower Format only and works as follows: The total number of external reference pulses received together with the scaling and setpoint indicates how many feedback pulses should have been received. The difference between the number that should have been received and the number actually received is called the position or phase error and is displayed at MV-49. When Position Loop is active, this error is resolved to zero.

The quickness with which the error is reduced to zero is directly proportional to the entry at CP-29. Entries of "zero" will never remove the position error, while entries much larger than "10" typically result in motor instabilities. Obviously, a position error cannot be eliminated without temporarily deviating from the specified ratio setpoint.

The best example may be cases where the master is always running at or near full process speed but the follower is occasionally stopped and restarted (flying starts). When the follower is started and during its acceleration to line speed it accumulates a significant position deficit which can only be eliminated by the follower operating at speeds in excess of the specified ratio for a sustained period of time. This situation can be controlled by the use of CP-18 and CP-19. The entry at CP-18 is the maximum number of feedback pulses that the follower will regain when it falls behind. Conversely, CP-19 is the maximum number of feedback pulses that the follower will fall back when it gets ahead. The particulars of the application will suggest reasonable values for CP-18 and CP-19. That is, Lead and Lag errors which should be considered routine and recoverable. It should be emphasized that the position error is calculated ignoring the Accel and Decel ramps and the position routine will, in extreme situations, overpower the ramp routine. This makes it important that appropriate, reasonable values be chosen for CP-16, CP-17, CP-18, CP-19 and CP-29.

OUTPUT 6

The final result of the M-Drive calculations is the applied motor voltage that appears across J2 pins 3 and 4. This applied voltage is created by phase firing the AC line every half cycle. The number of degrees of phase firing is derived from the Feed Forward, Trim Output and Trim Authority calculations.

INTRODUCTION

The M-Drive serial communications protocol utilizes a polling technique. A message or record is sent to the M-Drive from the host computer to establish communications. The M-Drive then responds with a confirming or error message.

Messages sent to the M-Drive can be categorized into three types:

1. Parameter Send
2. Data Inquiry
3. Control Command Send

The **Parameter Send** message is used to change any of the control parameters in the M-Drive (CP-xx). All of the parameters accessible via the front keypad are also accessible through the serial communications interface.

The **Data Inquiry** message is used to request the current value of any of the control parameters (CP-xx) or monitor variables (MV-xx) in the M-Drive.

The **Control Command Send** message is used to provide computer control of M-Drive Operations - e.g., run, stop, forward, reverse, etc.

All M-Drive messages use the USA Code for Information Interchange (see Appendix I).

This chapter is divided into seven sections. **M-Drive Serial Communications Setup** describes which CP-xx variables to alter to allow an individual M-Drive to utilize serial communications. The next six sections provide a character level description for each of the three message types and their responses:

Parameter Send - Host Transmission
Parameter Send - M-Drive Response

Data Inquiry - Host Transmission
Data Inquiry - M-Drive Response

Control Command Send - Host Transmission
Control Command Send - M-Drive Response

M-DRIVE SERIAL COMMUNICATIONS SETUP

The following parameters are used to physically structure a M-Drive to utilize the RS422 serial communications network.

70 - DEVICE ADDRESSES

The M-Drive has a settable physical address from 1 to 32. This is used to uniquely identify the individual M-Drive units on a multidropped RS422 line.

NOTE: Messages using a device address of zero are accepted by all M-Drive Units.

71 - BAUD RATE

There are six different baud or data rates for the M-Drive:

- 1 = 300 Baud
- 2 = 600 Baud
- 3 = 1200 Baud
- 4 = 2400 Baud
- 5 = 4800 Baud
- 6 = 9600 Baud

72 - CHARACTER FORMAT

The M-Drive accepts 3 different character formats:

- 1 = 8 Data Bits, No Parity, One Stop Bit
- 2 = 7 Data Bits, Even Parity, One Stop Bit
- 3 = 8 Data Bits, No Parity, Two Stop Bits

73 - CONTROL MASK

When the computer control is switch selected (See Local/ Computer on Page 3-14), it is possible to allow the computer to control some of the functions associated with the discrete switch inputs. These functions are:

- 1 = Ramp Enable/Disable
- 4 = Run/R-Stop
- 8 = Secondary Setpoint Select
- 16 = Primary Setpoint Select
- 32 = Closed/Open Loop
- 64 = Not Used
- 128 = Primary/Secondary Control Mode

To delegate control of the selected function to the computer, simply add the associated function number to the total. For example, a value of 132 for code 73 would mean the computer has control of the Primary/Secondary Mode and the Run/R-Stop functions.

Note: The computer changes these functions using the Control Command Send Message (Page 7-14).

PARAMETER SEND-HOST TRANSMISSION

CHAR #	1	2	3	4	5	6	7	8	9	10	11	12
DESC.	STX	Dev# 10s	Dev# 1s	MSG TYPE	Par# 10s	Par# 1s	DATA 1000s	DATA 100s	DATA 10s	DATA 1s	DATA FORM	ETX
ASCII	STX	0-9	0-9	3	0-9	0-9	0-9	0-9	0-9	0-9	0-7	ETX
HEX	02	30- 39	30- 39	33	30- 39	30- 39	30- 39	30- 39	30- 39	30- 39	30- 37	03

CHARACTER 1: STX

The leading STX character must be received by the M-Drive to enable the receive buffer. All characters are ignored until the STX character is received.

CHARACTERS 2 & 3: DEV

Characters 2 and 3 are the device number (address) of the M-Drive that is to be accessed. This number differentiates the individual M-Drive devices on the multidrop RS-422 communications line. Data is only accepted if there is a match between these characters and Control Parameter 70 (the Device Address set on the M-Drive). The only exception is device address 00, which is universally accepted by all the M-Drives on the RS-422 line.

CHARACTER 4: MSG TYPE

Should always be a 3 for a Parameter Send message.

CHARACTER 5 & 6: PARAMETER NUMBER

These characters are the Parameter Code numbers used to identify which Control Parameter is to be changed.

Appendix D lists all valid Control Parameters and their minimum and maximum values.

CHARACTERS 7 TO 10: DATA

These characters are used to transmit the new data for the selected parameter. Data must be within the range specified by Appendix D.

CHARACTER 11: DATA FORMAT

If the data is either negative or not integer, character 11 is used to code its format. This code determines how characters 7 through 10 are interpreted by the M-Drive.

Note: Data Format codes 1, 2, 3, 5, 6 and 7 are only valid for CP-20, CP-21, CP-22 and CP-23. All other decimal locations are either fixed or derived, and should use Code 0 for the Data Format Code.

<u>CODE</u>	<u>FORMAT</u>
0	+ XXXX
1	+ XXX.X
2	+ XX.XX
3	+ X.XXX
4	- XXXX
5	- XXX.X
6	- XX.XX
7	- X.XXX
8	+XX.XX.

CHARACTER 12: ETX

The message or record must always be terminated by the ASCII ETX character.

EXAMPLE:

A new acceleration time of 52.3 seconds is sent to the M-Drive with device address 4:

ASCII Representation: STX 0 4 3 1 6 0 5 2 3 0 ETX

HEX Representation:

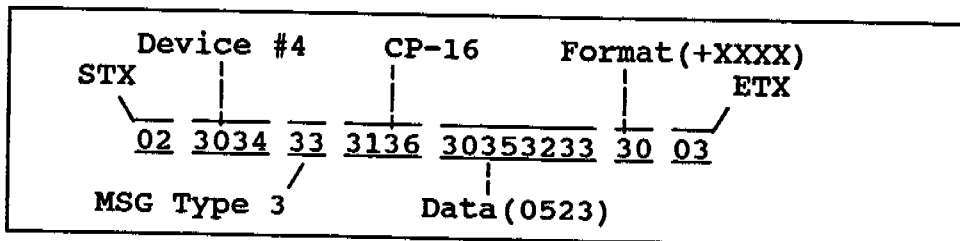

Note: Spaces are visual clarity only.

Note: The decimal point for CP-16 is fixed by the M-Drive.
(See the NOTE for Character 11 above.)

PARAMETER SEND - M-DRIVE RESPONSE

CHAR #	1	2	3	4	5	6	7	8	9	10	11	12
DESC.	STX	Dev# 10s	Dev# 1s	ERROR CODE	Par# 10s	Par# 1s	DATA 1000s	DATA 100s	DATA 10s	DATA 1s	DATA FORM	ETX
ASCII	STX	0-9	0-9	@ - DEL	0-9	0-9	0-9	0-9	0-9	0-9	0-7	ETX
HEX	02	30- 39	30- 39	40- 7F	30- 39	30- 39	30- 39	30- 39	30- 39	30- 39	30- 37	03

CHARACTER 1: STX

The leading character of the Response message is always the ASCII STX.

CHARACTERS 2 & 3: DEV

The next two characters are the device address.

Note: If the universal address is used in the Host Transmission, no response message is transmitted back to avoid line contention.

CHARACTER 4: ERROR CODE

The Error Code indicates if any errors existed in the send message received by the M-Drive. This character is bit structured and can be decoded as follows:

- Bit 7 - Always 0
- Bit 6 - Always 1
- Bit 5 - Data was out of minimum/maximum range
- Bit 4 - Invalid Parameter Code, Checksum or Decimal Point Error
- Bit 3 - Receive buffer filled before ETX received or Message Format Error
- Bit 2 - Invalid Parameter Data
- Bit 1 - Parity error
- Bit 0 - M-Drive in Local not Computer Mode.

Refer to Table 7-1 to transfer from the ASCII character sent back from the M-Drive and the corresponding binary bit structure.

Note: The ASCII error code @ (01000000 binary) (40 HEX) indicates that the Host Transmission contained no errors.

The M-Drive only accepts data if no errors were encountered.

ASCII	BINARY		ASCII	BINARY	
	Bit 7	Bit 0		Bit 7	Bit 0
@	0	10000000	,	0	11000000
A	0	10000001	a	0	11000001
B	0	10000010	b	0	11000010
C	0	10000011	c	0	11000011
D	0	10000100	d	0	11000100
E	0	10000101	e	0	11000101
F	0	10000110	f	0	11000110
G	0	10000111	g	0	11000111
H	0	10001000	h	0	11001000
I	0	10001001	i	0	11001001
J	0	10001010	j	0	11001010
K	0	10001011	k	0	11001011
L	0	10001100	l	0	11001100
M	0	10001101	m	0	11001101
N	0	10001110	n	0	11001110
O	0	10001111	o	0	11001111
P	0	10010000	p	0	11100000
Q	0	10010001	q	0	11100001
R	0	10010010	r	0	11100010
S	0	10010011	s	0	11100011
T	0	10010100	t	0	11100100
U	0	10010101	u	0	11100101
V	0	10010110	v	0	11100110
W	0	10010111	w	0	11100111
X	0	10011000	x	0	11110000
Y	0	10011001	y	0	11110001
Z	0	10011010	z	0	11110010
[0	10011011	{	0	11110011
\	0	10011100	~	0	11111000
]	0	10011101	}	0	11111001
^	0	10011110	~	0	11111010
_	0	10011111	DEL	0	11111111

Table 7-1: Error Code Translation -- ASCII to Binary

CHARACTERS 5 & 6: PARAMETER NUMBER

The Parameter Code number from the send message is echoed back in the return message.

CHARACTERS 7 TO 10: DATA

The Data from the send message is echoed back in the return message.

CHARACTER 11: DATA FORMAT

The Data Format character from the send message is echoed back in the return message.

CHARACTER 12: ETX

The return message is always terminated with the ASCII ETX character.

DATA INQUIRY-HOST TRANSMISSION

CHAR #	1	2	3	4	5	6	7	8	9	10	11	12
DESC.	STX	Dev# 10s	Dev# 1s	MSG TYPE	Par# 10s	Par# 1s	DATA 1000s	DATA 100s	DATA 10s	DATA 1s	DATA FORM	ETX
ASCII	STX	0-9	0-9	2	0-9	0-9	0	0	0	0	0	ETX
HEX	02	30- 39	30- 39	32	30- 39	30- 39	30	30	30	30	30	03

CHARACTER 1: STX

The leading character must always be the ASCII STX.

CHARACTERS 2 & 3: DEVICE NUMBER

The device address of the M-Drive.

CHARACTER 4: MSG TYPE

The message type is the ASCII 2 for a data inquiry message.

CHARACTERS 5 & 6: PARAMETER NUMBER

This is the parameter code number for the desired variable.

CHARACTERS 7 TO 10: DATA

Should be set to zero in the message to the M-Drive.

CHARACTER 11: DATA FORMAT

Should be set to zero in the message to the M-Drive.

CHARACTER 12: ETX

The message should terminate with the ASCII ETX character.

DATA INQUIRY - M-DRIVE RESPONSE

CHAR #	1	2	3	4	5	6	7	8	9	10	11	12
DESC.	STX	Dev# 10s	Dev# 1s	ERROR CODE	Par# 10s	Par# 1s	DATA 1000s	DATA 100s	DATA 10s	DATA 1s	DATA FORM	ETX
ASCII	STX	0-9	0-9	@ - DEL	0-9	0-9	0-9	0-9	0-9	0-9	0-7	ETX
HEX	02	30- 39	30- 39	40- 7F	30- 39	30- 39	30- 39	30- 39	30- 39	30- 39	30- 37	03

CHARACTER 1: STX

The leading character is the ASCII STX.

CHARACTERS 2 & 3: DEVICE NUMBER

The device address is echoed back.

CHARACTER 4: ERROR CODE

The Error Code is transmitted back as appropriate. See Parameter Send - Error Code for the bit pattern of the error code.

CHARACTERS 5 & 6: PARAMETER NUMBER

The Parameter Number is echoed back.

CHARACTERS 7 TO 10: DATA

This is the requested data for the selected parameter. See Data Explanation below.

CHARACTER 11: DATA FORMAT

This code tells how to interpret the returned data for positive, negative, and decimal point location.

Refer to Parameter Send - Data Format for the coding of this character.

CHARACTER 12: ETX

The message always terminates with the ASCII ETX character.

DATA EXPLANATION

Most data returned by the M-Drive in response to a Data Inquiry command can be easily interpreted via the Data and Data Format fields. However, a few variables return an eight bit coded response which must be decoded to allow interpretation. In general this number is between "0" and "255" decimal and is received as a four character ASCII representation of the decimal number. As an example, the bit structured value 10110111 binary = 183 decimal, and would be received as 0 1 8 3 ASCII or 30 31 38 33 HEX. This data structure applies to the following variables: MV-52, MV-53, MV-54 and CP-73.

To interpret an eight bit coded number, first convert it to binary using Table 7-2 on Page 7-11. Then refer to the appropriate Figure below to identify the M-Drive information.

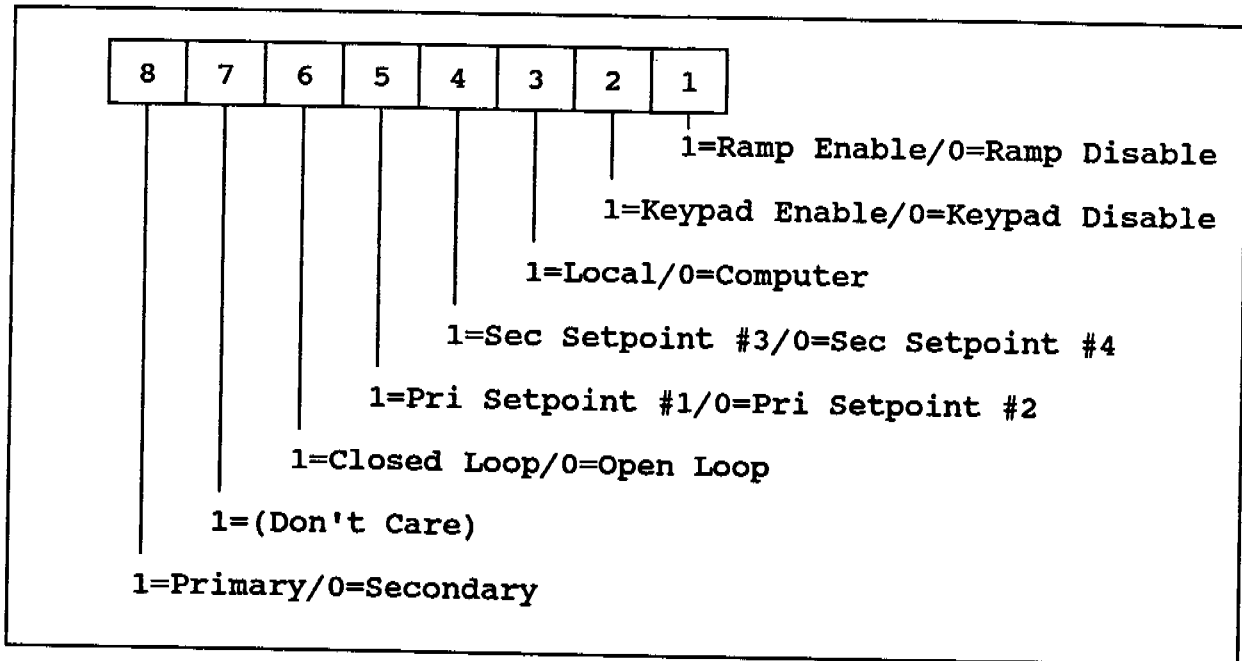
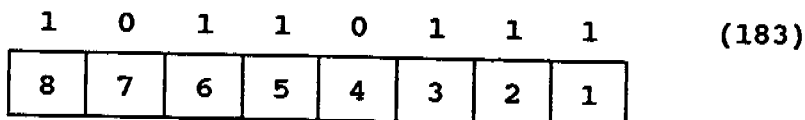

Figure 7-1: MV-54 Interpretation

As above, assume that 183 is returned by the M-Drive in response to MV-54 Data Inquiry Command. Using Table 7-2, the number 183 converts to 10110111:



Using Figure 7-1 above, 183 can now be interpreted to indicate the following M-Drive Status: Primary Mode, Closed Loop, Primary Setpoint #1, Secondary Setpoint #4, Local, Keypad Enable and Ramp Enable.

0	00000000	32	00100000	64	01000000	96	01100000
1	00000001	33	00100001	65	01000001	97	01100001
2	00000010	34	00100010	66	01000010	98	01100010
3	00000011	35	00100011	67	01000011	99	01100011
4	00000100	36	00100100	68	01000100	100	01100100
5	00000101	37	00100101	69	01000101	101	01100101
6	00000110	38	00100110	70	01000110	102	01100110
7	00000111	39	00100111	71	01000111	103	01100111
8	00001000	40	00101000	72	01001000	104	01101000
9	00001001	41	00101001	73	01001001	105	01101001
10	00001010	42	00101010	74	01001010	106	01101010
11	00001011	43	00101011	75	01001011	107	01101011
12	00001100	44	00101100	76	01001100	108	01101100
13	00001101	45	00101101	77	01001101	109	01101101
14	00001110	46	00101110	78	01001110	110	01101110
15	00001111	47	00101111	79	01001111	111	01101111
16	00010000	48	00110000	80	01010000	112	01110000
17	00010001	49	00110001	81	01010001	113	01110001
18	00010010	50	00110010	82	01010010	114	01110010
19	00010011	51	00110011	83	01010011	115	01110011
20	00010100	52	00110100	84	01010100	116	01110100
21	00010101	53	00110101	85	01010101	117	01110101
22	00010110	54	00110110	86	01010110	118	01110110
23	00010111	55	00110111	87	01010111	119	01110111
24	00011000	56	00111000	88	01011000	120	01111000
25	00011001	57	00111001	89	01011001	121	01111001
26	00011010	58	00111010	90	01011010	122	01111010
27	00011011	59	00111011	91	01011011	123	01111011
28	00011100	60	00111100	92	01011100	124	01111100
29	00011101	61	00111101	93	01011101	125	01111101
30	00011110	62	00111110	94	01011110	126	01111110
31	00011111	63	00111111	95	01011111	127	01111111

128	10000000	160	10100000	192	11000000	224	11100000
129	10000001	161	10100001	193	11000001	225	11100001
130	10000010	162	10100010	194	11000010	226	11100010
131	10000011	163	10100011	195	11000011	227	11100011
132	10000100	164	10100100	196	11000100	228	11100100
133	10000101	165	10100101	197	11000101	229	11100101
134	10000110	166	10100110	198	11000110	230	11100110
135	10000111	167	10100111	199	11000111	231	11100111
136	10001000	168	10101000	200	11001000	232	11101000
137	10001001	169	10101001	201	11001001	233	11101001
138	10001010	170	10101010	202	11001010	234	11101010
139	10001011	171	10101011	203	11001011	235	11101011
140	10001100	172	10101100	204	11001100	236	11101100
141	10001101	173	10101101	205	11001101	237	11101101
142	10001110	174	10101110	206	11001110	238	11101110
143	10001111	175	10101111	207	11001111	239	11101111
144	10010000	176	10110000	208	11010000	240	11110000
145	10010001	177	10110001	209	11010001	241	11110001
146	10010010	178	10110010	210	11010010	242	11110010
147	10010011	179	10110011	211	11010011	243	11110011
148	10010100	180	10110100	212	11010100	244	11110100
149	10010101	181	10110101	213	11010101	245	11110101
150	10010110	182	10110110	214	11010110	246	11110110
151	10010111	183	10110111	215	11010111	247	11110111
152	10011000	184	10111000	216	11011000	248	11111000
153	10011001	185	10111001	217	11011001	249	11111001
154	10011010	186	10111010	218	11011010	250	11111010
155	10011011	187	10111011	219	11011011	251	11111011
156	10011100	188	10111100	220	11011100	252	11111100
157	10011101	189	10111101	221	11011101	253	11111101
158	10011110	190	10111110	222	11011110	254	11111110
159	10011111	191	10111111	223	11011111	255	11111111

Table 7-2: Decimal to Binary Conversion

The following three figures provide the interpretations for the other eight bit coded variables. The technique to interpret these variables is identical to the MV-54 example demonstrated on Page 7-10,

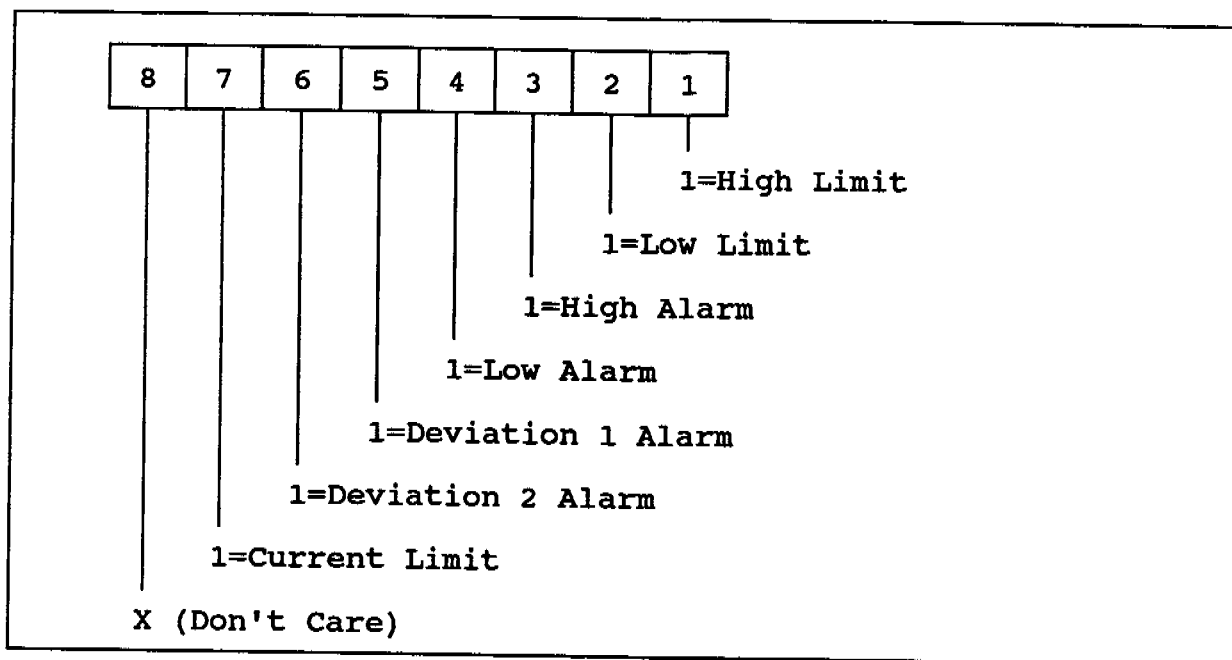

Figure 7-2: MV-52 Interpretation

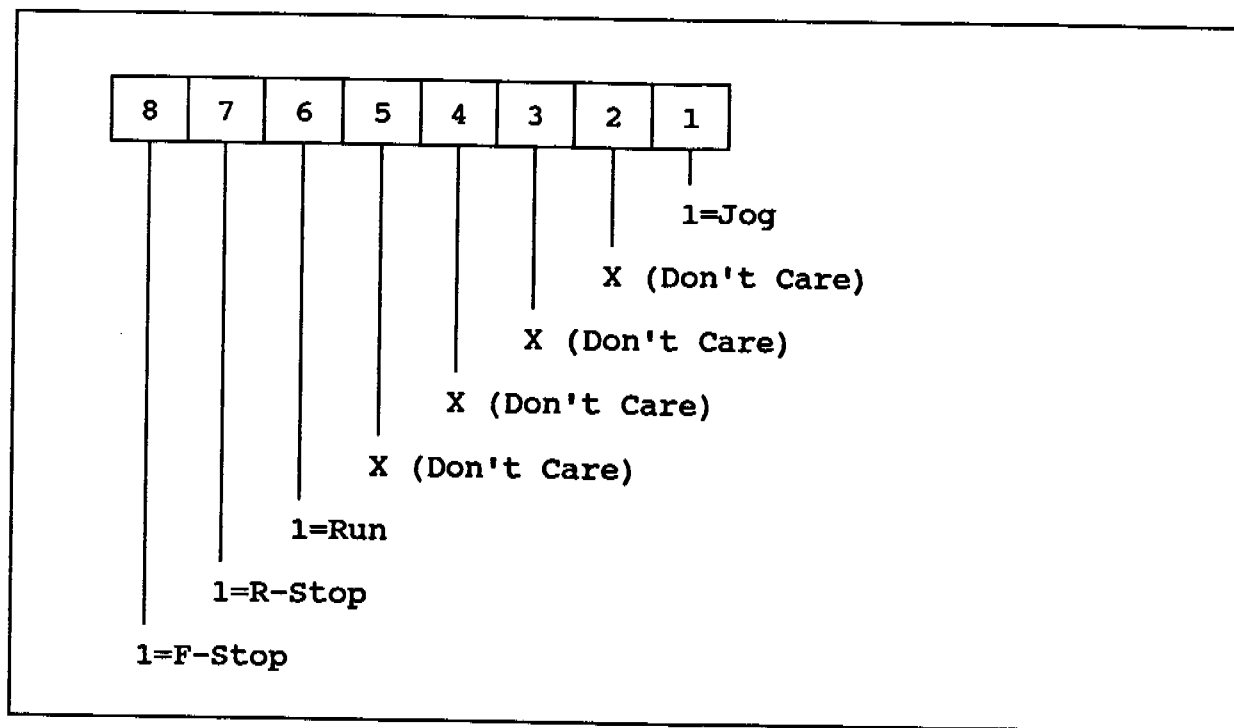

Figure 7-3: MV-53 Interpretation

Note: CP-73 indicates whether the computer has control over the listed variables.
 1 indicates that the computer has control, 0 indicates the computer does not have control.

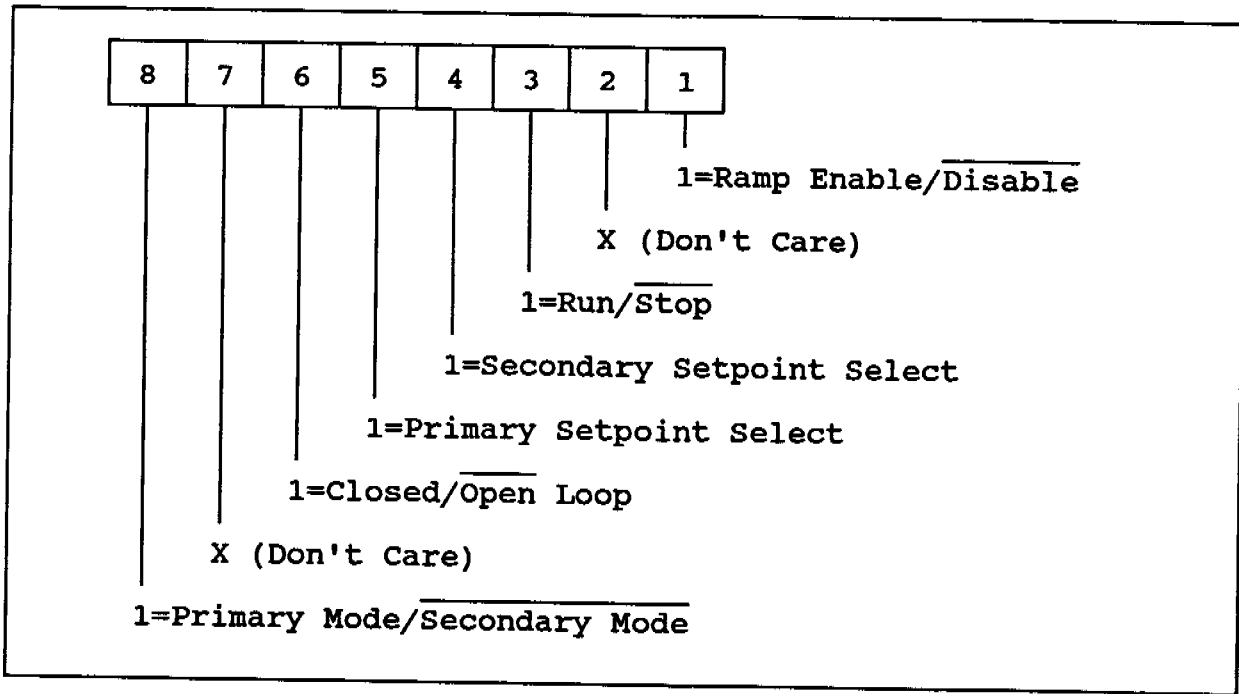

Figure 7-4: CP-73 Interpretation

CONTROL COMMAND SEND - HOST TRANSMISSION

CHAR #	1	2	3	4	5	6	7	8	9	10	11	12
DESC.	STX	Dev# 10s	Dev# 1s	MSG TYPE	Par# 10s	Par# 1s	DATA 1000s	DATA 100s	DATA 10s	DATA 1s	DATA FORM	ETX
ASCII	STX	0-9	0-9	1	0-9	0	0	0	0- 1	0- 9	0	ETX
HEX	02	30- 39	30- 39	31	30	30	30	30	30- 39	30- 39	30	03

CHARACTER 1: STX

The message always begins with the ASCII STX character.

CHARACTERS 2 & 3: DEVICE NUMBER

The desired M-Drive device address.

CHARACTER 4: MESSAGE TYPE

Set to 1 for this message type.

CHARACTERS 5 & 6: PARAMETER NUMBER

Set to 0 for this message type.

CHARACTERS 7 & 8: DATA 1000x & 100s

Set to 0 for this message type.

CHARACTERS 9 & 10: DATA 10s & 1s

Enter data control command character code as follows:

- 01 - Fast Stop
- 02 - Ramp Stop
- 03 - Run
- 04 - Enable Primary Mode
- 05 - Enable Secondary Mode
- 06 - Not Used
- 07 - Not Used
- 08 - Enable Closed Loop
- 09 - Enable Open Loop
- 10 - Enable Primary Setpoint 1
- 11 - Enable Primary Setpoint 2
- 12 - Enable Secondary Setpoint 3
- 13 - Enable Secondary Setpoint 4
- 14 - Ramp Disable
- 15 - Ramp Enable

CHARACTER 11: DATA FORMAT

Set to 0 for this message type.

CHARACTER 12: ETX

The message always terminates with the ASCII character ETX.

CONTROL COMMAND SEND - M-DRIVE RESPONSE

CHAR #	1	2	3	4	5	6	7	8	9	10	11	12
DESC.	STX	Dev# 10s	Dev# 1s	ERROR CODE	Par# 10s	Par# 1s	DATA 1000s	DATA 100s	DATA 10s	DATA 1s	DATA FORM	ETX
ASCII	STX	0-9	0-9	@ - DEL	0	0	0	0	0- 1	0- 9	0	ETX
HEX	02	30- 39	30- 39	40- 7F	30	30	30	30	30- 31	30- 39	30	03

CHARACTER 1: STX

The message always begins with the ASCII STX character.

CHARACTERS 2 & 3: DEVICE NUMBER

The device address of the M-Drive.

CHARACTER 4: ERROR CODE

Error Code for the received message.

See Parameter Send - Error Code for the bit pattern to decode the error message.

CHARACTERS 5 & 6: PARAMETER NUMBER

Always 0 for this message type.

CHARACTERS 7 & 8: DATA 1000s & 100s

Always 0 for this message type.

CHARACTERS 9 & 10: DATA 10s & 1s

The command mode from the receive message is returned by the M-Drive.

CHARACTER 11: DATA FORMAT

Always 0 for this message type.

CHARACTER 12: ETX

Message always terminates with the ETX character.

EXAMPLE PROGRAM

The following example program can be used to verify wiring and data format for the Communications Link.

```
10 '
20 '
30 ' FILENAME "PHELP"      REV 1
40 '
50 '
60 ' THIS SIMPLE PROGRAM CAN VERIFY M-TRIM/M-DRIVE COMM LINK WIRING & FUNCTION
70 ' IT WORKS WITH IBM CLASS COMPUTERS WITH BASIC/BASICA/GWBASIC
80 '
90 '
100 ' IT ASSUMES:
110 '     COMPUTER- COMM PORT IS #1
120 '         - EVEN PARITY, 7 DATA BITS, 1 STOP BIT, 300 BAUD
130 '     M-TRIM/M-DRIVE-
140 '         - ADDRESS= 1 (CODE 70= 1)
150 '         - BAUD= 300 (CODE 71= 1)
160 '         - CHARACTER FORMAT E,7,1 (CODE 72=2)
170 '         - JUMPER FOR COMPUTER MODE (J4-11/12)
180 '
190 '
200 ' ACTIVE PART OF PROGRAM FOLLOWS:
210 '
220 OPEN "COM1:300,E,7,1,RS,CS,DS,CD" AS #1 'OPEN COMM PORT
230 PRINT #1, CHR$(2);"0130112340";CHR$(3); 'SEND MESSAGE TO CONTROLLER
240 A$=INPUT$(12,1) 'RECEIVE REPLY AT COMPUTER
250 B$ = MID$(A$,7,4) 'PICK 4 DATA DIGITS (7-10TH CHAR)
260 PRINT B$ 'PRINT DATA DIGITS ON SCREEN
270 PRINT A$ 'PRINT WHOLE REPLY STRING
280 END
```

NOTE: Line 220 may require the elimination of the terms
"RS,CS,DS,CD" on certain computer models.

INTRODUCTION

This chapter explores some of the advanced programming capabilities of the M-Drive. These capabilities include two additional speed control formats, a form of position control and analog input/output. The five sections of this chapter are:

- Format Definition
- Direct Speed Control Format
- Offset Speed Control Format
- Additional Setpoint and Tachometer Possibilities
- Analog Input/Output (Optional)

FORMAT DEFINITION

Master and Follower speed control formats are both explained in chapter five. Two additional speed control formats are possible: Direct and Offset. The Direct speed control format is a method to command the M-Drive's drive output to a specific percentage of the output voltage, ignoring the scaling and feedback conditions. Direct is typically used for system trouble-shooting.

The Offset speed control format adds two independent process variables, with the resulting sum used to pace the M-Drive. An example of the Offset control format using a follower system with a dancer POT is provided in this chapter.

SELECTING A SPEED CONTROL FORMAT

As indicated in chapter five, the Primary/Secondary discrete input selects between Master and Follower. Therefore, the question arises "How are the additional speed control formats invoked?". The answer is that the M-Drive must be told which format to use as Primary and which to use as Secondary. This is done by entering the number associated with each format (as listed below) into CP-61 for Primary and CP-62 for Secondary. A review of the programming examples in chapter five shows that the first step was in fact defining CP-61 and CP-62.

<u>Number</u>	<u>Speed Control Format</u>
0	Direct
1	Master
2	Follower
3	Offset

Note also that many of the scaling constants (CP-20 through CP-39) divide themselves into a primary and secondary group. Thus, the typical programming procedure is as follows:

1. Determine the speed control format for Primary Mode.
2. Enter the appropriate number in CP-61.
3. Load system constants into the Primary Parameter Group.
4. Repeat steps 1 through 3 above for Secondary Mode, using CP-62 and the Secondary Parameter Group.

DIRECT SPEED CONTROL FORMAT

When using the Direct Speed Control Format, the operator is able to control the output to the motor directly. When operating in Direct Format, the M-Drive ignores Accel, Decel and Feedback values, and immediately changes the output to the requested level entered into CP-6. The normal RUN/STOP logic is complied with.

The example below illustrates Direct Format using Primary Mode (Secondary Mode would work as well).

OBJECTIVE: Run the motor drive at 10% of full output.

1. Enter a 0 into CP-61 thereby designating Primary Mode as using Direct Format.
2. Enter 10 into CP-6 (Output Setpoint).
3. Place the M-Drive into the RUN state.

RESULTS: The output should be at 10% of full output. The actual motor speed will depend on load characteristics, and will most likely not be 10% of the rated speed.

CAUTION: When operating in Direct Format, the current limit feedback is overridden by the M-Drive. Caution should be exercised to prevent equipment damage.

OFFSET SPEED CONTROL FORMAT

INTRODUCTION

The Offset Speed Control format differs from Follower Format in two respects:

1. Offset provides for a second process variable in addition to the External Reference Frequency.
2. Offset allows the programmer to specify a speed difference (or offset) from the normally calculated Follower speed.

Consequently, the Offset Format motor speed is controlled by four variables: Ratio Setpoint, External Reference Frequency, Auxiliary Reference Frequency, and the user specified offset.

Appendix B lists the actual formulas used to calculate the motor speed for both Follower Format and Offset Format.

OFFSET FORMAT EXAMPLE

Figure 8-1 below illustrates a simple web process. Note that this application contains a loop which is controlled by a dancer POT. The example illustrates the use of a voltage controlled oscillator from the dancer POT to the Auxiliary Frequency Input. (The Analog Input could also be used, eliminating the VCO.) The frequency output of the oscillator is then applied to J3 pin 8 of the Follower M-Drive. Depending on this output value, the M-Drive adjusts the speed of the Follower Motor up or down as required to maintain the dancer POT position.

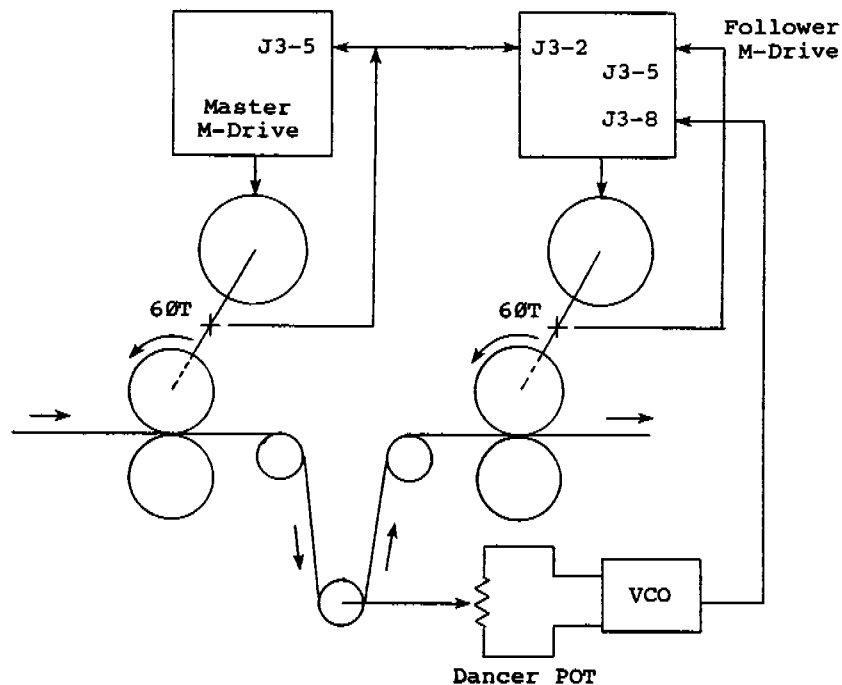

Figure 8-1: Web Process illustrating Offset Format

Recall that in this case two frequencies are used by the Follower M-Drive to determine the required follower Motor RPM: Line Speed (the external reference supplied by the Master Motor Feedback), and dancer POT position (the auxiliary reference supplied by the VCO). Also note that it is possible to control the gain on the POT displacement from the center position and to bias or offset the result with the user specified constant. The Tach is explained later in this chapter.

This example uses Secondary Mode, but the Primary Mode would work as well.

ASSUMPTIONS

- o Nip rolls in Figure 8-1 are 1 foot in circumference
- o Follower Motor is to draw the web at the same linear speed as the Master (1800 feet per minute at 1800 RPM)
- o Both gears have 60 teeth
- o Master is scaled as per chapter six (Page 6-5)
- o Desired Follower Setpoint is 1.000
- o VCO output range is 0 - 1000 Hz (500 Hz = dancer centered)
- o Full scale authority of the dancer POT is 10% of full speed (i.e., a 1000 Hz change in Aux Frequency should result in a 180 RPM change in the follower motor speed).

Ignoring the dancer pot, first program the M-Drive to follow at the proper line speed:

<u>Control Parameter</u>	<u>Parameter Title</u>	<u>Entered Data</u>	<u>Remarks</u>
CP-62	Secondary Scaling Format	3	Designates Secondary as Offset Format
CP-37	Secondary RPM Feedback Maximum	1800	Maximum RPM of the shaft which the feedback sensor is monitoring (normal operation)
CP-36	Secondary RPM External Reference Maximum	1800	Maximum RPM of the shaft which the external reference sensor is monitoring (normal operation)
CP-21	Secondary Setpoint Engineering Units	1.000	Desired setpoint when the Ext. Ref. and Feedback shafts are rotating at the speeds entered at CP-37 and CP-36
CP-31	PPR Feedback	60	Number of teeth on the gear or number of lines on the encoder used for feedback
CP-30	PPR Ext Ref.	60	Number of teeth on the gear or number of lines on the encoder used for external reference

The next step is to program the Auxiliary Reference Frequency input which represents the Dancer POT position (the VCO output). Two characteristics of this input must be controlled: Offset and Gain. The Offset determines which frequency will have no effect on the M-Drive's speed (i.e., which position the dancer POT stabilizes at). The Gain determines how large an impact on the speed a given change in the Auxiliary Reference Frequency will have. As the Auxiliary Frequency source (in this case) is a VCO instead of a gear and sensor, it may be helpful to review the material on alternative frequency sources on Page 5-16.

Recall that the authority or gain of the dancer POT was assumed to be 10%. To accomplish this, entries are made indicating that the maximum expected Auxiliary Reference Frequency is 10,000 Hz when in fact it will never exceed the 1000 Hz output of the VCO. This provides the 10 to 1 reduction needed.

Control Parameter	Parameter Title	Entered Data	Remarks
CP-38	Secondary RPM Auxil. Maximum	1000	
CP-32	PPR Aux. Ref.	600	These two entries imply the 10,000 Hz maximum as required

The last step is to enter an offset so that a centered POT (500 Hz) has no effect. This offset depends on the gain and is calculated using the formula:

$$C = - \left[\frac{AX * R_{fmx} * P_f}{R_{amx} * P_a} \right]$$

Where:

- C = the required offset
- R_{fmx} = the maximum RPM of the feedback shaft (CP-37) in the example.
- P_f = PPR of the gear on the feedback shaft (CP-31)
- R_{amx} = the maximum RPM of the auxiliary shaft (CP-38)
- P_a = PPR of the gear on the auxiliary shaft (CP-32)
- AX = the frequency at which the POT is to be neutralized (500 Hz)

 Refer to the programming conventions used when using Hz instead of RPM and PPR as discussed in Chapter 5.

Replacing the variables with the example numbers, the Offset is then calculated. Note the minus sign in front of the right-hand expression.

$$C = \frac{- 500 * 1800 * 60}{1000 * 600}$$

$$C = - 90$$

<u>Control Parameter</u>	<u>Parameter Title</u>	<u>Entered Data</u>	<u>Remarks</u>
CP-78	Secondary Negative Offset	90	Programming is complete

CP-77 and CP-78 work together in that CP-77 is a plus offset and CP-78 is a negative offset. Note that only one of these parameters can have a non-zero value at a time. Whenever an entry is made at one location, the M-Drive automatically sets the other to zero. Codes CP-75 and CP-76 work the same but are in the Primary Parameter group.

ADDITIONAL SETPOINT AND TACHOMETER POSSIBILITIES

SETPOINT POSSIBILITIES

The programmer is not prevented from designating the same format for both Primary and Secondary modes. E.g., CP-61 and CP-62 could both be loaded with a "2", giving two independent Follower formulas. In addition, both parameter groups could be loaded with the same system constants but four setpoints would be available.

TACHOMETER POSSIBILITIES

Chapter five assumed that the Master Format tach would always indicate the speed of the motor scaled in some appropriate engineering unit, and that the Follower Format tach would display a ratio between the two motors. Just as it is possible to use any combination of speed scaling formats and modes, it is possible to use any combination of tach scaling formats and modes. The most likely case is probably a Follower Speed control using a speed tach instead of a ratio tach.

ANALOG INPUT/OUTPUT PROGRAMMING (OPTIONAL)

ANALOG INPUT

The Analog Input can be used to replace any of the three frequency inputs or four setpoint values. To allocate the Analog Input to a specific function, enter the correct value for CP-84 according to the table below:

<u>Value</u>	<u>Analog Function</u>
0	Not Used
1	External Reference Frequency Replacement
2	Feedback Frequency Replacement
3	Offset Frequency Replacement
4	CP-1 (Setpoint 1) Replacement
5	CP-2 (Setpoint 2) Replacement
6	CP-3 (Setpoint 3) Replacement
7	CP-4 (Setpoint 4) Replacement

Table 8-1: CP-84 - Analog Input Allocation Codes

When the Analog Input is allocated to replace one of the frequency inputs, the M-Drive automatically adjusts the corresponding PPR and RPM MAX codes for that frequency input. It sets the PPR value to 60 and RPM MAX values to 4095. For example, if the user enters a value of 1 for CP-84, the M-Drive then sets CP-30 to 60, CP-33 to 4095 and CP-36 to 4095. This is equivalent to having an input frequency of 4095 HZ (4095 RPMs with a 60 tooth gear) when the Analog Input is at its maximum level.

To complete the programming process, simply enter in the desired Engineering Unit values (at CP-20 through CP-23 and CP-75 through CP-78) that correspond to the maximum Analog Input value.

If an analog input level less than full scale is used, it is necessary to proportionally adjust the appropriate Engineering Unit parameter. For example, if a 0 to 5 VDC input corresponds to an Engineering Unit of 15 gallons/minute, the user enters an Engineering Unit value of 30 gallons/minute for the 0 to 10 VDC equivalent value.

The following examples illustrate the use of the Analog Input in the Master, Follower and Offset Modes.

MASTER FORMAT, ANALOG INPUT AS SETPOINT

ASSUMPTIONS

- o A pump delivers 15 gallons/minute when the motor rotates at 1725 RPMs.
- o An analog POT connected to the M-Drive analog input produces a 5 volt DC level when the motor rotates at 1725 RPMs.
- o Both Setpoint and the Tach are to indicate gallons per minute.

To accomplish these objectives, program the M-Drive as follows:

<u>Control Parameter</u>	<u>Parameter Title</u>	<u>Entered Data</u>	<u>Remarks</u>
CP-84	Analog Function	4	Allocates Analog Input as CP-1 (Setpoint 1) replacement.
CP-61	Primary Scaling Format	1	Designates Master as the Primary Scaling Format.
CP-63	Primary Display Format	1	Designates Master as the Primary Display Format
CP-31	PPR Feedback	60	Designates the value used as a multiplier to obtain the desired authority of the analog input.
CP-34	Primary RPM MAX Feedback	1725	Designates maximum RPM of Feedback sensor shaft.
CP-20	Primary Setpoint Engr. Units	30.00	Designates the maximum setpoint engineering units at the maximum analog level of 10 VDC.
CP-22	Primary Display Engr. Units	15.00	Designates the maximum display engineering units.

MASTER FORMAT, ANALOG INPUT AS FEEDBACK

ASSUMPTIONS

- o A pump delivers 15 gallons/minute when the motor rotates at 1725 RPMs.
- o An analog tach connected to the M-Drive analog input produces a 10 volt DC level when the motor is to rotate 1725 RPMs.
- o Both Setpoint and the Tach are to indicate gallons per minute.

To accomplish these objectives, program the M-Drive as follows:

<u>Control Parameter</u>	<u>Parameter Title</u>	<u>Entered Data</u>	<u>Remarks</u>
CP-84	Analog Function	2	Allocates Analog Input as feedback frequency replacement
CP-61	Primary Scaling Format	1	Designates Master as the Primary Scaling Format
CP-63	Primary Display Format	1	Designates Master as the Primary Display Format
CP-31	PPR Feedback	60	<u>Not Entered.</u> Automatically entered by the M-Drive and cannot be altered.
CP-34	Primary RPM MAX Feedback	4095	<u>Not Entered.</u> Automatically entered by the M-Drive and cannot be altered.
CP-20	Primary Setpoint Engr. Units	15.00	Designates the maximum setpoint engineering units.
CP-22	Primary Display Engr. Units	15.00	Designates the maximum display engineering units.

FOLLOWER FORMAT, ANALOG INPUT AS EXTERNAL REFERENCE

ASSUMPTIONS

- o The Setpoint and Tach are to reflect the flow ratio in gallons/minute of B to A.
- o The Motor/Pump combination used for Component A delivers 10 gallons/minute at 1725 RPMs.
- o The Motor/Pump combination used for Component B delivers 30 gallons/minute at 1725 RPMs.

- o An analog tach produces 10 VDC when the motor on Component A is at 1725 RPMs.
- o A 30 tooth gear is used for the follower feedback (Component B)

CALCULATIONS

1. Determine the flow ratio that exists when both components are flowing at maximum rates.

$$\frac{30 \text{ Gal/minute (Component B)}}{10 \text{ Gal/minute (Component A)}} = 3.000$$

To accomplish the above objectives, program the M-Drive as follows:

<u>Control Parameter</u>	<u>Parameter Title</u>	<u>Entered Data</u>	<u>Remarks</u>
CP-84	Analog Function	1	Allocates the analog input as ext. ref. freq. replacement
CP-62	Secondary Scaling Format	2	Designates Follower as the Secondary setpoint scaling format
CP-64	Secondary Display Format	2	Designates Follower as the Secondary display scaling format
CP-37	Secondary RPM Feedback Max	1725	Maximum RPM of the shaft which the feedback sensor monitors
CP-36	Secondary RPM External Ref. MAX	4095	<u>Not Entered.</u> Automatically entered by the M-Drive and cannot be altered.
CP-31	PPR Feedback	30	Number of teeth on the gear or number of lines on the encoder used for feedback
CP-30	PPR External Reference	60	<u>Not Entered.</u> Automatically entered by the M-Drive and cannot be altered.
CP-21	Secondary Setpoint Engn. Units	3.000	
CP-23	Secondary Display Engn. Units	3.000	

OFFSET FORMAT, ANALOG INPUT AS AUX FREQUENCY

INTRODUCTION

The Offset Speed Control format differs from Follower Format in two respects:

1. Offset provides for a second process variable in addition to the External Reference Frequency.
2. Offset allows the programmer to specify a speed difference (or offset) from the normally calculated Follower speed.

Consequently, the Offset Format motor speed is controlled by four variables: Ratio Setpoint, External Reference Frequency, Analog Input as Aux (Offset) Frequency, and the user specified offset.

Appendix B lists the actual formulas used to calculate the motor speed for both Follower Format and Offset Format.

OFFSET FORMAT EXAMPLE

Figure 8-2 below illustrates a simple web process. Note that this application contains a loop which is controlled by a dancer POT. The example uses a dancer POT on the Analog Input. Depending on the output value, the M-Drive adjusts the speed of the Follower Motor up or down as required to maintain the dancer POT position.

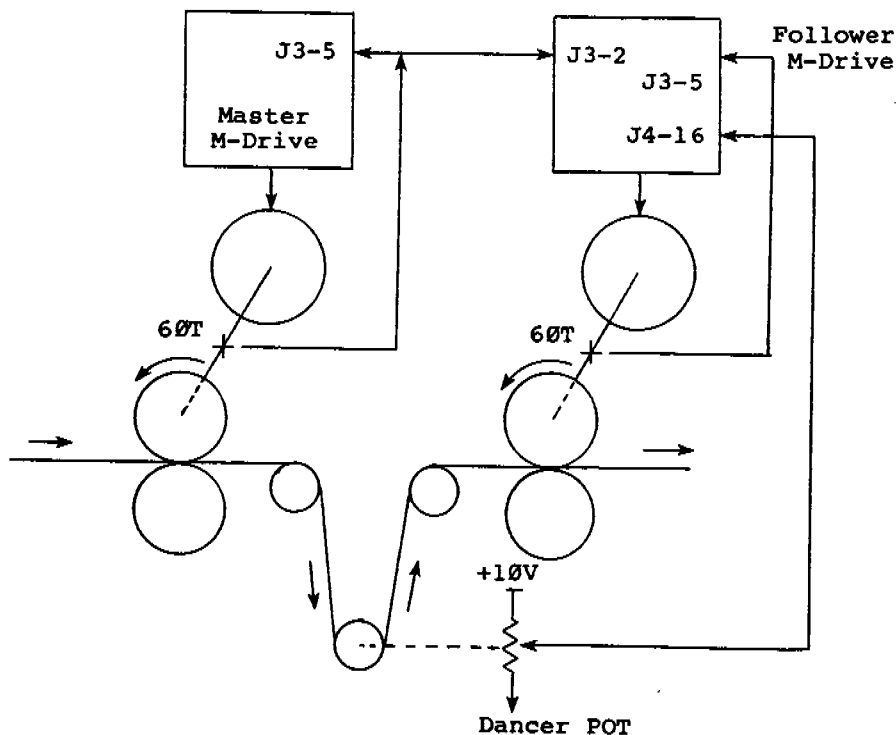

Figure 8-2: Web Process illustrating Offset Format with Analog Input

Recall that in this case two inputs are used by the Follower M-Drive to determine the required follower Motor RPM: Line Speed (the external reference supplied by the Master Motor Feedback), and dancer POT position (the analog input). Also note that it is possible to control the gain on the POT displacement from the center position and to bias or offset the result with the user specified constant. The Tach is explained later in this chapter.

This example uses Secondary Mode, but the Primary Mode would work as well.

ASSUMPTIONS

- o Nip rolls in Figure 8-1 are 1 foot in circumference
- o Follower Motor is to draw the web at the same linear speed as the Master (1800 feet per minute at 1800 RPM)
- o Both gears have 60 teeth
- o Master is scaled as per chapter six (Page 6-5)
- o Desired Follower Setpoint is 1.000
- o POT output range is 0 - 10 Volts (5 volts = dancer centered)
- o Full scale authority of the dancer POT is 10% of full speed (i.e., a 10 Volt change in analog input should result in a 180 RPM change in the follower motor speed).

Ignoring the dancer pot, first program the M-Drive to follow at the proper line speed:

<u>Control Parameter</u>	<u>Parameter Title</u>	<u>Entered Data</u>	<u>Remarks</u>
CP-62	Secondary Scaling Format	3	Designates Secondary as Offset Format
CP-37	Secondary RPM Feedback Maximum	1800	Maximum RPM of the shaft which the feedback sensor is monitoring (normal operation)
CP-36	Secondary RPM External Reference Maximum	1800	Maximum RPM of the shaft which the external reference sensor is monitoring (normal operation)
CP-21	Secondary Setpoint Engineering Units	1.000	Desired setpoint when the Ext. Ref. and Feedback shafts are rotating at the speeds entered at CP-37 and CP-36
CP-31	PPR Feedback	60	Number of teeth on the gear or number of lines on the encoder used for feedback
CP-30	PPR Ext Ref.	60	Number of teeth on the gear or number of lines on the encoder used for external reference

The next step is to program the analog input which represents the Dancer POT position. Two characteristics of this input must be controlled: Offset and Gain. The Offset determines which equivalent frequency will have no effect on the M-Drive's speed (i.e., which position the dancer POT stabilizes at). The Gain determines how large an impact on the speed a given change in the analog input will have.

The output of the analog converter is 4095 when the analog input is at 10 Volts. To obtain the equivalent frequency value, a data entry of 4095 is made for the Maximum AUX RPM parameter and 60 for the PPR parameter. This would give the dancer 100% authority at the 10 volt level.

Recall that the authority or gain of the dancer POT was assumed to be 10%. To accomplish this, entries are made indicating that the maximum expected equivalent Auxiliary Frequency is 40,950 Hz when in fact it will never exceed the 4095 output of the analog converter. This provides the 10 to 1 reduction needed.

$$(CP-32 = 60 * 100\% \text{ trim desired})$$

<u>Control Parameter</u>	<u>Parameter Title</u>	<u>Entered Data</u>	<u>Remarks</u>
CP-84	Analog Function	3	Allocates analog input as offset frequency replacement (must be entered first).
CP-38	Secondary RPM Auxil. Maximum	4095	<u>Not Entered</u> . Automatically entered by the M-Drive and cannot be altered.
CP-32	PPR Aux. Ref.	600	These two entries imply the 40,950 Hz as required

The last step is to enter an offset so that a centered POT (5 Volts) has no effect. This offset depends on the gain and is calculated using the formula:

$$C = - \left[\frac{AX * R_{fmx} * P_f}{R_{amx} * P_a} \right]$$

Where:

- C = the required offset
- R_{fmx} = the maximum RPM of the feedback shaft (CP-37) in the example.
- P_f = PPR of the gear on the feedback shaft (CP-31)
- R_{amx} = the maximum equivalent RPM of the auxiliary shaft (CP-38 from above)
- P_a = equivalent PPR of the gear on the auxiliary shaft (CP-32 from above)
- AX = the equivalent frequency at which the POT is to be neutralized:

$$\frac{5 \text{ Volts} * 4095}{10 \text{ Volts}} = 2048$$

Replacing the variables with the example numbers, the Offset is then calculated. Note the minus sign in front of the right-hand expression.

$$C = \frac{- 2048 * 1800 * 60}{4095 * 600}$$

$$C = - 90$$

<u>Control Parameter</u>	<u>Parameter Title</u>	<u>Entered Data</u>	<u>Remarks</u>
CP-78	Secondary Negative Offset	90	Programming is complete

CP-77 and CP-78 work together in that CP-77 is a plus offset and CP-78 is a negative offset. Note that only one of these parameters can have a non-zero value at a time. Whenever an entry is made at one location, the M-Drive automatically sets the other to zero. Codes CP-75 and CP-76 work the same but are in the Primary Parameter group.

ANALOG INPUT AS A SETPOINT

The Analog Input can also be used to replace one of the four setpoints, CP-1 through CP-4. When the Analog Input is patched as a setpoint source, the setpoint value equals the Engineering Unit setpoint value (CP-20 or CP-21) when the Analog Input is at its maximum value (10 VDC or 20 mA).

For example, consider the following assumptions:

- o The M-Drive selected setpoint is CP-1
- o The Engineering Units (CP-20) are 1000 gallons/minute
- o The Analog Input is at 5.0 Volts (50%)

CALCULATIONS

$$SV = \frac{AI * EU}{AI_{max}}$$

Where

- SV = Setpoint Value
- AI = Analog Input level
- AI_{max} = 10 VDC or 20 mA
- EU = Engineering Units

Substituting the assumptions into the formula:

$$SV = \frac{5.0 * 1000}{10.0} = 500.$$

Thus, the Setpoint Value is 500 gallons/minute. This value can be observed at CP-1 when the analog input is patched as the setpoint source (i.e., when CP-84 equals 4).

ANALOG OUTPUT

The Analog Output can be used to provide an analog signal indicating the status of any of the M-Drive monitor variables or control parameters. To allocate the Analog Output to the desired variable or parameter, enter the code number for that variable into CP-80. For example, if it was desired to bring the Tach value out the Analog Output, a value of 40 should be entered for CP-80.

To range the Analog Output for the desired signal level, enter the maximum variable value for the selected variable corresponding to the maximum analog output into CP-81. For example, if the Tach value of 2000 was desired for the maximum analog output level (10 VDC or 20 mA), then a value of 2000 should be entered into CP-81. Note that negative variable values will produce negative analog signals.

The Analog Output is intended for monitoring M-Drive variables and system performance. Caution should be exercised when using the Analog Output for cascade control as the Analog Output response is damped to approximately 1 HZ.

INTRODUCTION

This chapter contains information designed to assist in diagnosing and solving M-Drive problems, and is divided into the following sections:

- | | |
|--------------------------|---|
| Power Up | Describes the Power Up tests which occur during every M-Drive Power Up (Page 9-1) |
| Diagnostics | Provides information for running the M-Drive Diagnostic Routines (Page 9-2) |
| Trouble-shooting | Provides information to assist in solving typical M-Drive maintenance problems (9-6) |
| Spare Parts List | Lists the available spare parts which can be ordered from the factory (Page 9-12) |
| EPROM Replacement | Contains a procedure for replacing the EPROM (Page 9-12) |
| Restore Settings | Provides a procedure which restores the M-Drive to the default factory settings (Page 9-13) |

If the information in this chapter does not solve your problem with the M-Drive, consult the factory.

The Fenner service number is 1-800-FIC-4411.

POWER UP

These routines are performed during every M-Drive Power Up.

1. RAM TEST

1. If RAM fails, a number is displayed (RAM Address = Displayed number + 49152) (C0000 HEX). Consult Factory.
 - a) Test stops if a failure is detected. Press clear to continue test.
2. If RAM is good, exit is automatic (0.0.0.0 is displayed)

2. PROM TEST

1. Performs a checksum comparison.
2. If test fails, an error code is displayed:
 - a) Test stops if a failure is detected. Press clear to continue test.
3. If PROM is good, exit is automatic.

DIAGNOSTICS

The M-Drive contains a number of internal diagnostic routines designed to verify that the M-Drive is running correctly, and to identify specific M-Drive problems if they occur. The first set of diagnostic routines are initiated by a specific power up procedure, while the second set of diagnostics involve entering M-Drive input values, and verifying subsequent M-Drive frequency calculations.

CLEAR/8 POWER UP TESTS

Initiate Test

1. Remove power from the M-Drive.
2. While simultaneously pressing "Clear" and "4" on the Operator Keypad, apply power to the M-Drive.
Response: "1" is shown in the lower display.
If a "1" does not appear on the lower display, repeat step 2 using the "Clear" and "8" keys.
3. Press the UP or DOWN keys to select which of the seven tests to initiate.
Each of the seven tests can be performed without repeating steps 1 and 2 above.
4. Press CODE SELECT key to exit diagnostics.

1. RAM TEST

1. Display "1" in the M-Drive lower display.
2. Press ENTER to start test.
3. If RAM fails, a number is displayed (RAM Address = Displayed number + 49152) (C0000 HEX). Consult Factory.
 - a) Test stops if a failure is detected. Press clear to continue test.
4. If RAM is good exit is automatic (0.0.0.0 is displayed).

2. DISPLAY TEST

1. Display "2" in the M-Drive lower display.
2. Press ENTER to start test.
3. M-Drive displays the following:

000000000
111111111
222222222
333333333
444444444
555555555
666666666
777777777
888888888
999999999

The following LEDs are illuminated in order:
Setpoint, Tach, Code Select, Run, Jog, Preset
Limit Alarm, Dev Alarm.

0.0.0.0 is then displayed
Display goes blank.

(Incorrect Display indicates failure)

3. KEYPAD TEST

1. Display "3" in the M-Drive lower display.
2. Press ENTER to start test.
3. Press each Operator Keypad Key. The M-Drive displays a number according to the key pressed:

<u>Press</u>	<u>Display</u>	<u>Press</u>	<u>Display</u>
-	-	SETSPEED	10
.	.	TACH	11
0	0	ENTER	12
1	1		13
2	2		14
3	3	Code Select	15
4	4	Clear	
5	5		
6	6		
7	7		
8	8		
9	9		

4. Press CLEAR to exit test.

4. INPUT TEST

1. Display "4" in the M-Drive lower display.
2. Press ENTER to start test.
3. Close input switches. The M-Drive displays a number according to the input pressed.

<u>Input Closure</u>		<u>Display</u>	<u>Input Closure</u>		<u>Display</u>
R-STOP	(J3-11)	1	Ramp Dis	(J4-7)	9
RUN	(J3-13)	2	P 1/2	(J4-9)	10
F-STOP	(J3-14)	3	S 3/4	(J4-10)	11
JOG	(J3-16)	4	Local/Rem	(J4-12)	12
Key Lock	(J4-1)	5	Remt UP	(J4-13)	13
Pri/Sec	(J4-3)	6	Remt DN	(J4-15)	14
Spare	(J4-4)	7			
Loop	(J4-6)	8			

4. Press CLEAR to exit test.

5. OUTPUT TEST

1. Display "5" in the M-Drive lower display.
2. Press ENTER to start test.
3. Press keys 1 - 7 to enable outputs. Pull-up resistors and meter or LED is required.

<u>Key</u>	<u>Output</u>	<u>Key</u>	<u>Output</u>
1	Zero Speed	4	Dev 1
2	High Alarm	5	Dev 2
3	Lo Alarm		

4. Press CLEAR to exit test.

6. SERIAL INPUT TEST

Prerequisites: Jump J1 Pin 4 to J1 Pin 2 and
Jump J1 Pin 5 to J1 Pin 3

1. Display "6" in the M-Drive lower display.
2. Press ENTER to start test.
3. M-Drive displays 300 if 300 baud failure.
M-Drive displays 2400 if 2400 baud failure.
M-Drive displays 9600 if 9600 baud failure.
4. Exit is automatic (0.0.0.0 is displayed)

7. CODE # TEST

1. Display "7" in the M-Drive lower display.
2. Press ENTER to start test.
3. M-Drive displays date code of software.
4. Press CLEAR to exit test.

VERIFYING M-DRIVE FREQUENCY CALCULATIONS

1. Frequency Input Test

1. Connect VC0 frequency into:
 - a) External Reference Frequency Input
 - b) Feedback Frequency Input
 - c) Offset Frequency Input
2. Verify proper input calculations by checking the following M-Drive Monitor Variables:
 - a) MV-41 (External Reference Frequency)
 - b) MV-42 (Offset Frequency)
 - c) MV-43 (Feedback Frequency).

2. Drive Output Test

1. Set CP-61 to 0.
2. Set Code 6 variables from 0 to +100
3. Check Drive for correct output.

3. Run Motor Test

1. Test M-Drive running a Motor at 1800 RPM.

TROUBLE-SHOOTING

INTRODUCTION

The trouble-shooting section is organized using a symptom/ response format. On the left side of the page are symptoms, conditions or instructions, and on the right side of the page are cross-references indicating an additional routine to perform.

In general, identify which category from section 1 (Symptoms) applies for your problem, and then follow the cross-referenced routine on the following pages to identify the probable cause (and solution) for the M-Drive malfunction.

NOTE: IAW indicates "In Accordance With".

WARNING

Hazardous voltages are present during certain procedures in this chapter. Therefore, these procedures should only be performed by qualified electrical maintenance personnel.

1. Symptoms

	Perform Routine #
1.1 M-Drive processor operates incorrectly	
1.2 Motor does not stop	2.
1.3 Motor does not run	3.
1.4 Motor runs at wrong speed	4.
1.5 Motor runs at correct speed but does not run fast enough	5.
1.6 Motor runs at correct speed but does not run slow enough	6.
1.7 Motor runs unstable	7.
1.8 Tach reads incorrectly	8.
1.9 Display shows ---1 or ---2	10.

2. Motor Does Not Stop

2.1 Check MV-53 (RUN/STOP STATE)

- If MV-53 = 128, then 2.2
- If MV-53 = 64, then 2.2
- If MV-53 = 32, then J3 pin 13 is (at least momentarily) shorted to common
- If MV-53 = 1, then J3 pin 16 is shorted to common

2.2 Measure voltage of J2-Pin 4 with respect to J2-Pin 3.

- If voltage = zero
 - Verify motor armature wiring.
- If voltage not = zero
 - Consult MV-54 and Page C-9 to determine if Ramp is disabled.
 - If true, J4-Pin 7 is shorted to common.
 - If false, call factory.

3. Motor Does Not Run

3.1 Check MV-53

- If MV-53 = 128, then J3 Pin 14 is not shorted to common
- If MV-53 = 64, then J3 Pin 11 is (at least momentarily) not shorted to common
- If MV-53 = 32, then check fuses on Power Drive Board *
- If MV-53 = 1, then check fuses on Power Drive Board

4. Motor Runs at Wrong Speed

4.1 Determine M-Drive control format

- If Master, then 4.2
- If Follower, then 4.3
- If Offset, then 4.4
- If Jog, then 4.5
- If Direct, then 4.6

4.2 Master Control Format

- Check MV-53
 - If MV-53 not = 32, then 9.1
- Check MV-50 (Active Format)
 - If MV-50 not = 1, then 9.2
- Check Setpoint
 - If setpoint incorrect, then enter correct setpoint and exit Trouble-shooting outline.
- Check MV-45 (Scaled Reference)
 - If MV-45 incorrect, then 9.3
 - IF MV-45 correct, then 4.7

* In addition to the logic fuse on the rear of the M-Drive, there are two power fuses located on the M-Drive Power Drive Board. These are used to protect the power drive portion of the M-Drive. Remove the rear plate and pull out the Power Drive Board to replace these fuses (Fenner Part No 6441-0315).

4.3 Follower Control Format	
Check MV-53	
If MV-53 not = 32, then	9.1
Check MV-50	
If MV-50 not = 2, then	9.2
Check Setpoint	
If setpoint incorrect, then enter correct setpoint and exit Trouble-shooting outline.	
Check MV-45 (Scaled Reference)	
If MV-45 incorrect, then	9.3
IF MV-45 correct, then	4.7
4.4 Offset Control Format	
Check MV-53	
If MV-53 not = 32, then	9.1
Check MV-50	
If MV-50 not = 3, then	9.2
Check Setpoint	
If setpoint incorrect, then enter correct setpoint and exit Trouble-shooting outline.	
Check MV-45 (Scaled Reference)	
If MV-45 incorrect, then	9.3
If MV-45 correct, then	4.7
4.5 Jog Control Format	
Check MV-53	
If MV-53 not = 1, then	9.1
Check CP-5 (Jog Setpoint)	
If CP-5 incorrect, then enter correct setpoint and exit Trouble-shooting outline.	
Check MV-45 (Scaled Reference)	
If MV-45 incorrect, then	9.3
IF MV-45 correct, then	4.7
4.6 Direct Control Format	
Check MV-53	
If MV-53 not = 32, then	9.1
Check MV-50	
If MV-50 not = 0, then	9.2
Check CP-6 (Direct Setpoint)	
If CP-6 incorrect, then enter correct setpoint and exit Trouble-shooting outline.	
If CP-6 correct, then	4.12
4.7 Check MV-46 (Ramped Reference)	
If MV-46 correct, then	4.8
If MV-46 incorrect, then consult Table 9-1 to determine if Ramp is disabled, else Ramp is in Progress.	

- 4.8 Consult Table 8-1 for Open/Closed Loop status
If Closed Loop, then
If Open Loop, then J4-Pin 6 is shorted to common 4.9
- 4.9 Check MV-68 (Trim Authority)
Most systems should be able to operate with trim authorities as low as 20%. If this is not true, either the system (drive) is nonlinear, under powered, or improperly scaled.
If CP-68 < 20, then set CP-68 to 20 or higher
If CP-68 > 20, then 4.10
- 4.10 Check CP-66 (Reset)
This value should be the smallest reset possible consistent with stable operation.
2000 - 4000 is reasonable.
- 4.12 Check Motor Armature and field connections
5. Motor Runs at Correct Speed but does not Run Fast Enough
5.1 Check CP-11 (Maximum RPM)
5.2 Verify current limit calibrations IAW Page 4-1.
6. Motor Runs at Correct Speed but does not Run Slow Enough
6.1 Check CP-10 (Minimum RPM)
7. Motor Runs Unstable
7.1 Enter 100 at CP-68, and tune the M-Drive IAW Page 5-12.

8. Tach Reads Incorrectly

8.1 Check MV-54 and Table 9-1 to insure M-Drive is operating Closed Loop.

8.2 Check MV-44

If MV-44 is not near zero, then motor is not running at the correct speed 4.

8.3 Verify MV-54 is correct using the appropriate formula from 9.3 9.3

8.4 Check MV-54 and Table 9-1 to determine if M-Drive is in Primary or Secondary Mode.

If Primary Mode, Check MV-63.

If M-Drive in Primary Mode and MV-63=1, then calculate tach indication:

$$MV-40 = (CP-22 * MV-43 * 60) / (CP-34 * CP-31)$$

If M-Drive in Primary Mode and MV-63=2, then calculate tach indication:

$$MV-40 = \frac{(CP-22 * MV-43 * CP-33 * CP-30)}{(MV-41 * CP-34 * CP-31)}$$

If Secondary Mode, Check MV-64.

If M-Drive in Secondary Mode and MV-64=1, then calculate tach indication:

$$MV-40 = (CP-23 * MV-43 * 60) / (CP-37 * CP-31)$$

If M-Drive in Secondary Mode and MV-64=2, then calculate tach indication:

$$MV-40 = \frac{(CP-23 * MV-43 * CP-36 * CP-30)}{(MV-41 * CP-37 * CP-31)}$$

9. System Checks

9.1 RUN/STOP LOGIC

If MV-53 = 128, then J3-Pin 14 is not shorted to common.

If MV-53 = 64, then J3-Pin 11 was not (at least temporarily) shorted to common.

If MV-53 = 32, then J3-Pin 13 was (at least temporarily) shorted to common.

If MV-53 = 1, then J3-Pin 16 is shorted to common.

9.2 Format

Consult MV-54 and Table 7-1 to verify Primary/Secondary mode.

If Primary Mode, enter proper format into CP-61.

If Secondary Mode, enter proper format in CP-62.

9.3 Scaled Reference

Determine Mode and Format, then calculate MV-45 per the correct equation.

MODE FORMAT EQUATION

PRI 0 MV-45=0

PRI 1 $MV-45 = (SP * CP34 * CP31) / (CP20 * 60)$

PRI 2 $MV-45 = \frac{(SP * MV41 * CP34 * CP31)}{(CP20 * CP33 * CP-30)}$

PRI 3 $MV-45 = \frac{(SP * MV41 * CP34 * CP31)}{(CP20 * CP33 * CP-30)} +$
 $(MV42 * CP34 * CP31) / (CP35 * CP32) +$
 $(CP75 - CP76).$

SEC 0 MV-45=0

SEC 1 $MV-45 = (SP * CP37 * CP31) / (CP21 * 60)$

SEC 2 $MV-45 = \frac{(SP * MV41 * CP37 * CP31)}{(CP21 * CP36 * CP-30)}$

SEC 3 $MV-45 = \frac{(SP * MV41 * CP37 * CP31)}{(CP21 * CP36 * CP-30)} +$
 $(MV42 * CP37 * CP31) / (CP38 * CP32) +$
 $(CP77 - CP78).$

10. Brown Out Watch Dog (---1, ---2 or ---3 displayed)

A display reading of ---1, ---2 or ---3 indicates an M-Drive environment problem; i.e., electrical noise severe enough to disrupt the microprocessor or a temporary interruption of AC power requirements. Generally, ---1 indicates an AC power problem, ---2 indicates noise, and ---3 indicates noise has disrupted the parameter RAM. If a ---2 or ---3 appears, the programming Control Parameters should be verified and a Clear 7 procedure performed (see Page 9-13).

SPARE PARTS LIST

<u>Part Number</u>	<u>Description</u>
6441-0200	Fuse 1A
6441-0315	Fuse 15A
6340-0021	Shunt Jumper
6310-0226	7 Position Terminal Connector (Power Drive Board)
6310-0224	16 Position Terminal Connector (CPU Board)
6310-0227	16 Position Terminal Connector (Drive Board)
6310-0228	18 Position Terminal Connector (CPU Board)
3200-1680	Analog Input/Output Option Board
Call Factory	PROM Number

EPROM LOCATION

It is possible that the EPROM may be replaced at the customer's location. Figure 9-1 below illustrates the location of this EPROM.

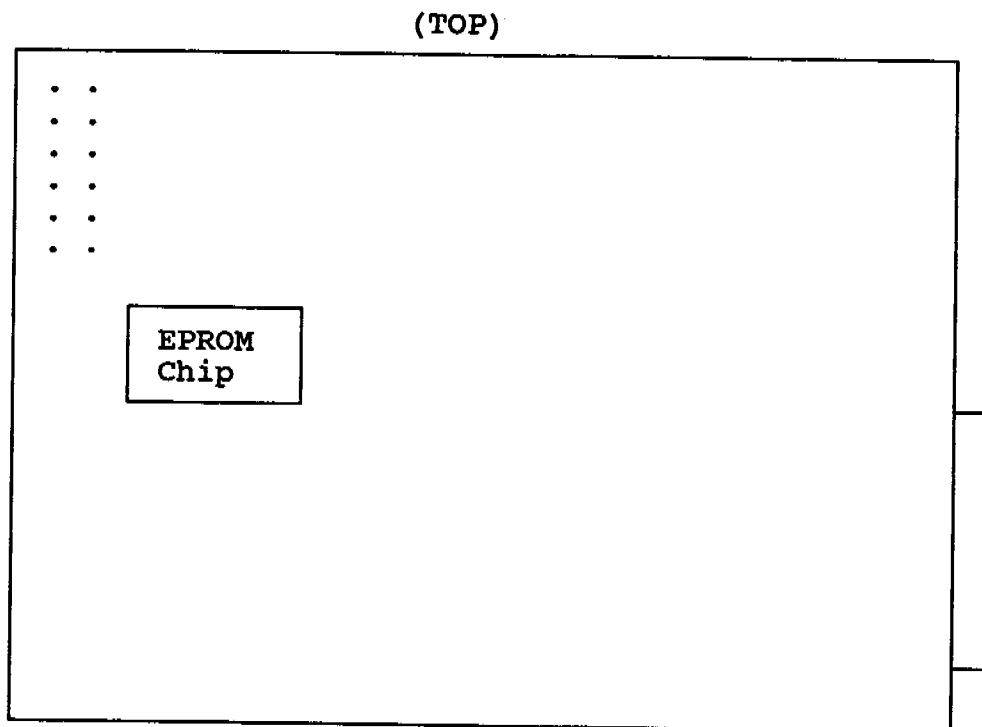

Figure 9-1: EPROM Location

RESTORE SETTINGS

CAUTION

This procedure restores the M-Drive to the factory default settings. Any User-entered parameters or programming will be erased.

1. Remove power from the M-Drive.
2. While pressing "Clear" and "7" on the Operator Keypad, apply power to the M-Drive.
Response: The M-Drive restores the factory default settings, and then performs the Power Up routine described on Page 9-1.

NOTES

INTRODUCTION

For the M-Drive to accurately control a motor, the M-Drive must receive a feedback signal reflecting the actual motor speed. This appendix contains information concerning three methods to provide this signal: Ring Kits, Bracket mount sensors, and Encoders or proximity sensors.

RING KITS

A ring kit is used to provide a magnetic sensor which detects the actual speed of the motor being controlled. This ring kit is typically comprised of 2 parts: A machined aluminum ring with a specific number of gear teeth and a specific bore diameter, and a magnetic pickup which mounts in the ring.

Ring kits are divided into two groups: Standard Ring Kits, and XP Ring Kits. XP is an abbreviation for Explosion Proof.

STANDARD RING KITS

NEMA C-FACE RING MOUNT

Best performance is achieved with a SM3N-A magnetic pickup mounted in a C-face ring. Shielded cable connections to the magnetic pickup are made by soldering and taping inside the conduit adapter box as shown below.

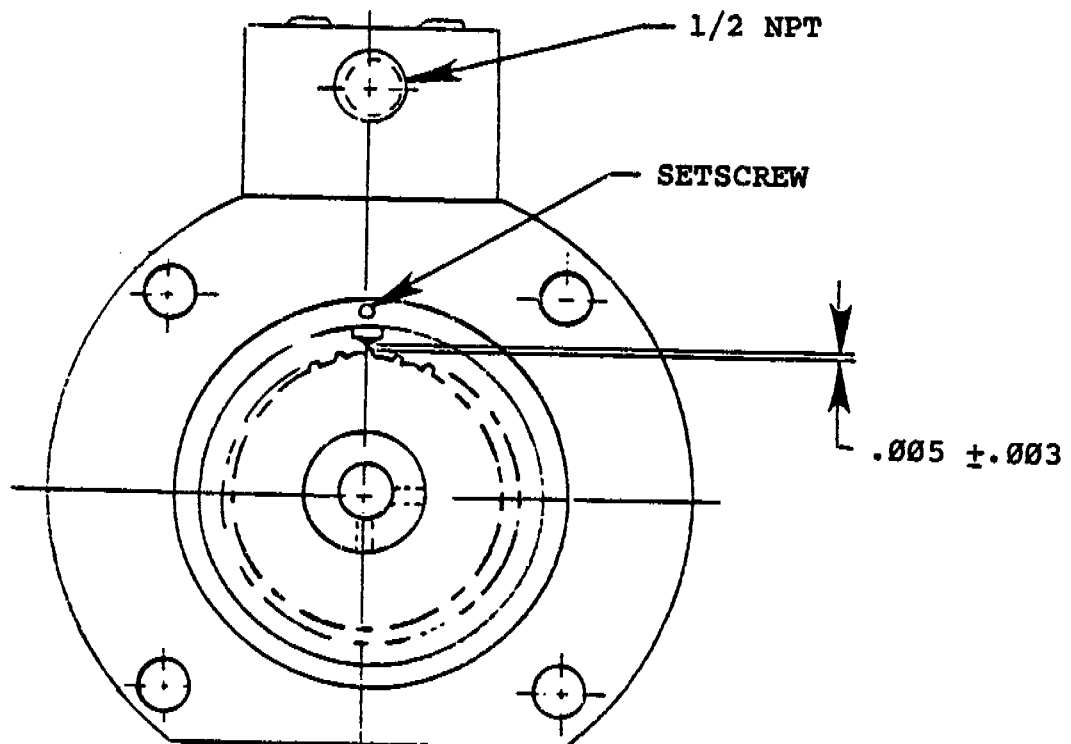

Figure A-1: SM3N-A Magnetic Pickup

XP RING KITS

The 7000-0450 Nema 56C pickup mounting ring used in the XP (explosion proof) kits is 1.280 inches thick and when "sandwiched" between a 56C frame XP motor and a gear box reduces the shaft engagement into the gear box by 1.280 inches.

For this application, a 3 to 5 inch armature shaft which is one inch longer than standard must be specified.

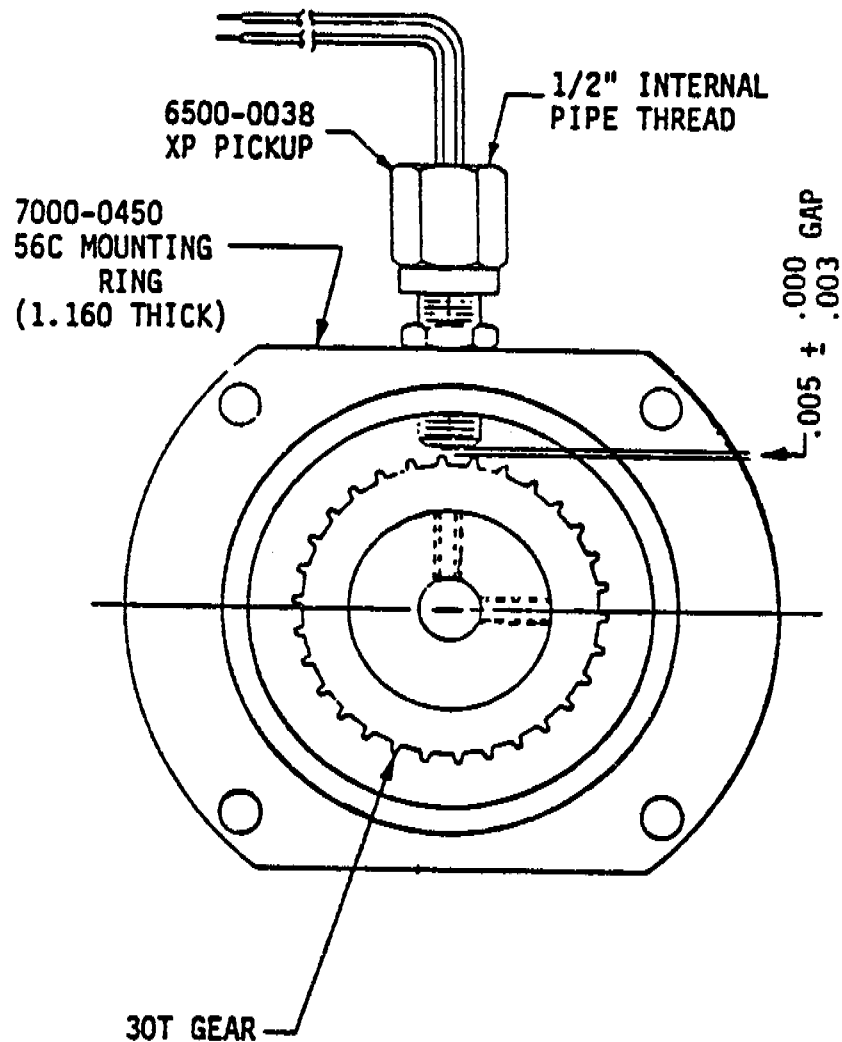
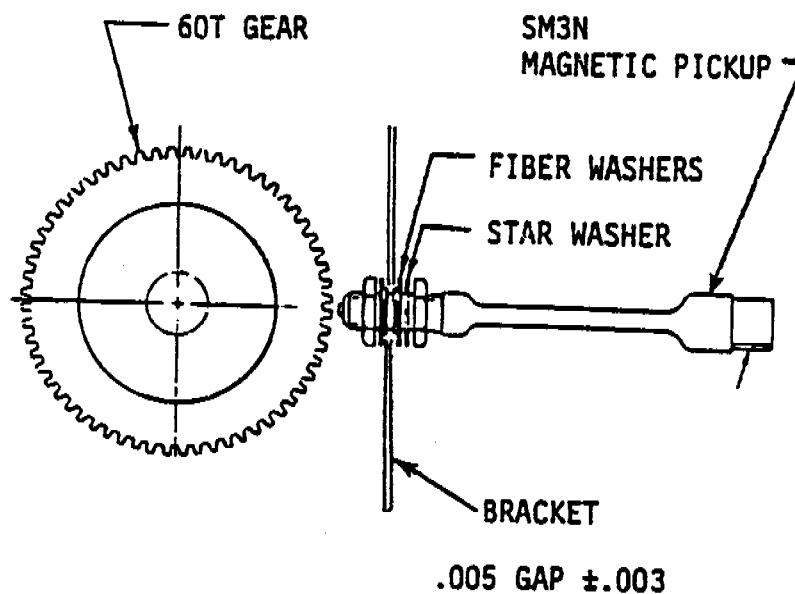

Figure A-2: XP Magnetic Pickup Ring Mounting

BRACKET MOUNT SENSORS

Bracket mount sensors are usually magnetic pickup sensors or proximity sensors, and do not require the use of an aluminum ring. Figure A-3 below is a typical example of a bracket mounted sensor.

Figure A-3 illustrates an SM3N magnetic pickup assembly which is mounted through a .437 clearance hole in a formed metal bracket fabricated by the user. The metal bracket must be sturdy and mounted to avoid vibrations and machine resonance.



*Installed to insulate pickup
from the bracket.

Figure A-3: Typical Bracket Mounted Magnetic Pickup

FEEDBACK SENSOR PARTS LIST

RING KITS:

<u>Part Number</u>	<u>Model Number</u>	<u>Description</u>
7300-0980	RK56C	Sensor Kit w/60T gear - 5/8 inch
7300-0982	RK143TC	Sensor Kit w/60T gear - 7/8 inch
7300-0934	RK182TC	Sensor Kit w/60T gear - 1 1/8 inch
7300-0936	RK213TC	Sensor Kit w/60T gear - 1 3/8 inch
7300-0987	RK254TC	Sensor Kit w/60T gear - 1 5/8 inch
7300-0981	RK56C-30	Sensor Kit w/30T gear - 5/8 inch
7300-0983	RK143TC-30	Sensor Kit w/30T gear - 7/8 inch
7300-0984	RK182TC-30	Sensor Kit w/30T gear - 1 1/8 inch
7300-0985	RK213TC-30	Sensor Kit w/30T gear - 1 3/8 inch
7300-0986	RK254TC-30	Sensor Kit w/30T gear - 1 5/8 inch
7300-1310	RK56C	Quadrature Ring Kit - 5/8 inch
7300-1311	RK143TC	Quadrature Ring Kit - 7/8 inch

SENSOR ACCESSORIES:

<u>Part Number</u>	<u>Model Number</u>	<u>Description</u>
5800-1410	SM3N	Magnetic Pickup, Threaded
5800-1412	SM3N-A	Magnetic Pickup, Smooth
6500-0038	SM5XP	Magnetic Pickup, Explosion Proof
3100-1190	SP8IS	Proximity Sensor, Intrinsically safe with amp
5800-1413	SP8N3	Proximity Sensor, 3-wire
3200-1340	ENC DR-600	Encoder, 10v, 600 PPR
3200-1350	ENC DR-1200	Encoder, 10v, 1200 PPR
7000-0450	R56CXP	Flange Ring only, 56C, for SM5XP sensor

GEARS:

<u>Part Number</u>	<u>Model Number</u>	<u>Description</u>
5800-0340	G60T5	Gear, 60T, 5/8 inch
5800-0341	G60T7	Gear, 60T, 7/8 inch
5800-0435	G60T9	Gear, 60T, 1 1/8 inch
5800-0345	G60T11	Gear, 60T, 1 3/8 inch
5800-0346	G60T13	Gear, 60T, 1 5/8 inch
7300-0376	G20T2	Sprocket, 20T, 1/4 inch
5800-0382	G30T5	Gear, 30T, 5/8 inch
5800-0383	G30T7	Gear, 30T 7/8 inch
5800-0347	G30T9	Gear, 30T, 1 1/8 inch
5800-0348	G30T11	Gear, 30T, 1 3/8 inch
5800-0349	G30T13	Gear, 30T, 1 5/8 inch

APPENDIX B - FORMULAS

B

INTRODUCTION

This appendix contains the actual formulas used to calculate M-Drive Speed Control values, and is divided into two sections. **Symbols** defines each symbol used by these formulas, and **Speed Control Formulas** provides 3 methods of calculating Speed Control Equations for Master, Follower and Auxiliary Reference Frequency Formats.

SYMBOLS

SP	Setpoint
EU	Engineering Unit (Maximum Setpoint)
Rf	RPM of Subject Shaft
Rfmx	Maximum Rf
Pf	PPR of gear on Subject Shaft
Re	RPM of External Reference Shaft
Remx	Maximum Re
Pe	PPR of gear on External Reference Shaft
Ra	RPM of Auxilliary Reference Shaft
Ramx	Maximum Ra
Pa	PPR of gear on Auxilliary Reference Shaft
C	Offset constant
ER	External Reference Frequency
FB	Feedback Frequency
AX	Auxilliary Reference Frequency

SPEED CONTROL FORMULAS

These equations are stated using three different methods: General, Hz, and RPM.

MASTER FORMAT

GENERAL: $\frac{SP}{EU} = \frac{Rf}{Rfmx}$

Hz: $\frac{SP}{EU} * \frac{Rfmx * Pf}{60} = FB$

RPM: $\frac{SP}{EU} * Rfmx = Rf$

FOLLOWER FORMAT

GENERAL: $\frac{SP}{EU} * \frac{Re}{Remx} = \frac{Rf}{Rfmx}$

Hz: $\frac{SP}{EU} * \frac{ER * Rfmx * Pf}{Remx * Pe} = FB$

RPM: $\frac{SP}{EU} * \frac{Re * Rfmx}{Remx} = Rf$

AUXILIARY REFERENCE FREQUENCY FORMAT

GENERAL: $\frac{SP}{EU} * \frac{Re}{Remx} + \frac{Ra}{Ramx} + \frac{C}{(Rfmx * Pf) / 60} = \frac{Rf}{Rfmx}$

Hz: $\frac{SP}{EU} * \frac{ER * Rfmx * Pf}{Remx * Pe} + \frac{AX * Rfmx * Pf}{Ramx * Pa} + C = FB$

RPM: $\frac{SP}{EU} * \frac{Re * Rfmx}{Remx} + \frac{Ra * Rfmx}{Ramx} + \frac{C}{Pf / 60} = Rf$

INTRODUCTION

This appendix provides in numeric order a complete list of all control and monitor code select variables present in the M-Drive. The Code Select Procedure is also provided.

CODE SELECT PROCEDURE

The Code Select Procedure indicates how the operator gains access to the various control and monitor parameters through their unique identification codes. Opening the lower door on the front of the M-Drive keypad exposes the programming keypad.

Accessing the desired parameter is a simple procedure:

- 1) Press the Code Select Key.
- 2) Enter the desired parameter code number.
- 3) Press the Enter Key.

At this point, the two digit code is displayed in the lower display window and the existing parameter value is displayed in the upper four digit display window. In addition, the keypad is enabled for changing the desired parameter. To make a change, simply enter the new value and press the Enter Key.

1 - PRIMARY SETPOINT 1

Primary Setpoint 1 is invoked when the M-Drive is in the Primary Scaling Mode and the Primary Setpoint Select switch input is open. This setpoint is the absolute setpoint if the Primary Scaling Mode is programmed as a Master Scaling Mode. This setpoint is the multiplier ratio if the Primary Scaling Mode is programmed for Follower Scaling Mode.

This parameter is entered in engineering units. The decimal point location and scaling for this entry is set up through the Scaling procedure (Code Select 20).

2 - PRIMARY SETPOINT 2

Primary Setpoint 2 is invoked when the M-Drive is in the Primary Scaling Mode and the Primary Setpoint Select switch is closed. This setpoint is the absolute setpoint if the Primary Scaling Mode is programmed as a Master Scaling Mode. This setpoint is the multiplier ratio if the Primary Control Mode is programmed for Follower Scaling Mode.

3 - SECONDARY SETPOINT 1

Secondary Setpoint 1 is invoked when the M-Drive is in the Secondary Scaling Mode and the Secondary Setpoint select switch is open. This setpoint is the absolute setpoint for the Master Scaling Mode and the multiplier ratio for the Follower Scaling Mode.

4 - SECONDARY SETPOINT 2

Secondary Setpoint 2 is invoked when the M-Drive is in the Secondary Scaling Mode and the Secondary Setpoint select switch input is closed. This setpoint is the absolute setpoint for the Master Scaling Mode and the multiplier ratio for the Follower Scaling Mode.

5 - JOG SETPOINT

This is the setpoint source for Jog operation. This entry is always entered in RPMs.

6 - OUTPUT SETPOINT

Output Setpoint is the setpoint source when the Direct Scaling is invoked by either the Primary or Secondary Scaling Modes. This setpoint directly sets the output level, in percent, of the Drive Output to the motor.

10 - MINIMUM LIMIT

This parameter sets the minimum level of RPMs for operation. Although it is possible to enter a setpoint below this level, the control will always attempt to maintain a speed at or above the minimum limit except to recover position error.

11 - MAXIMUM LIMIT

This parameter sets the maximum level of RPMs for operation. Although it is possible to enter a setpoint above this limit, the control will always attempt to maintain a speed at or below the maximum limit except to recover position error.

12 - LOW ALARM

This parameter sets the RPM level at which the Low Alarm output is energized. The output will energize when the feedback RPMs are at or below this level.

13 - HIGH ALARM

This parameter sets the RPM level at which the High Alarm output is energized. The output will energize when the feedback is at or above this RPM level.

14 - ERROR ALARM 1 - RAMPED ERROR

This parameter establishes the error band (Ramped Reference minus feedback) in RPMs at which the Error Alarm 1 output is energized. Any positive or negative error at or above this level will energize the output.

15 - ERROR ALARM 2 - SCALED ERROR

This parameter establishes the error band (Scaled Reference minus feedback) in RPMs at which the Error Alarm 2 output is energized. Any positive or negative error at or above this level will energize the output.

16 - ACCELERATION TIME

Acceleration Time determines the acceleration rate of the setpoint. The number entered is the amount of time required to increase the setpoint from 0 to 2000 RPMs.

17 DECELERATION TIME

Deceleration Time determines the deceleration rate of the setpoint. The number entered is the amount of time (in seconds) required to decrease the setpoint from 2000 to 0 RPMs.

18 - LAG PULSE LIMIT

The Lag Pulse Limit sets a maximum pulse error count for the difference between the idealized feedback pulses minus the Feedback pulses. It may not always be desirable to recover all of the position error lag. Set this parameter to the desired lag pulse limit.

19 - LEAD PULSE LIMIT

The Lead Pulse Limit sets a maximum pulse error count when the Feedback pulses exceed the idealized feedback pulse count. Set this parameter to the desired lead pulse limit.

20 - ENGINEERING UNITS (PRIMARY SETPOINT)

This is the desired Engineering Units scaling number for the primary Scaling Mode setpoint.

21 - ENGINEERING UNITS (SECONDARY SETPOINT)

This is the desired Engineering Units scaling number for the Secondary Scaling Mode setpoint.

22 - ENGINEERING UNITS (PRIMARY DISPLAY)

This is the desired Engineering Units scaling number for the Primary Scaling Mode display.

23 - ENGINEERING UNITS (SECONDARY DISPLAY)

This is the desired Engineering Units scaling number for the Secondary Scaling Mode display.

29 - RECOVERY MULTIPLIER

The Recover Multiplier determines the rate at which the pulse error is reduced to zero. This parameter multiplied by the pulse error count is the number by which the speed setpoint is adjusted every 100 milliseconds.

30 - PPR (EXTERNAL REFERENCE INPUT)

This number should be set for the Pulses per Revolution of the External Reference Frequency Input.

31 - PPR (FEEDBACK INPUT)

This number should be set for the Pulses per Revolution of the Feedback Frequency Input.

32 - PPR (AUXILIARY INPUT)

This number should be set for the Pulses per Revolution of the Auxiliary Frequency Input if present.

33 - MAX RPM (EXTERNAL REFERENCE INPUT: PRIMARY MODE)

This parameter should be set for the maximum RPMs of the External Reference Frequency Input when operating in the Primary Scaling Mode.

34 - MAX RPM (FEEDBACK: PRIMARY MODE)

This parameter represents the maximum RPMs of the Feedback Frequency Input when operating the Primary Scaling Mode.

35 - MAX RPM (AUXILIARY INPUT: PRIMARY MODE)

This parameter represents the maximum RPMs of the Auxiliary Frequency Input when operating in the Primary Scaling Mode.

36 - MAX RPM (EXTERNAL REFERENCE INPUT: SECONDARY MODE)

This parameter represents the maximum RPMs of the External Reference Input when operating in the Secondary Scaling Mode.

37 - MAX RPM (FEEDBACK: SECONDARY MODE)

This parameter represents the maximum RPMs of the Feedback Frequency Input when operating in the Secondary Scaling Mode.

38 - MAX RPM (AUXILIARY INPUT: SECONDARY MODE)

This parameter represents the maximum RPMs of the Auxiliary Frequency Input when operating in the Secondary Scaling Mode.

40 - TACH

Tach is the feedback displayed in scaled engineering units. The feedback input is read by the M-Drive every 10 milliseconds. The readings are summed and averaged for one second before displaying.

41 - EXTERNAL REFERENCE INPUT

The External Reference Input displays the frequency of this input in hertz (pulses per second). The number displayed is not averaged. It represents the frequency calculation from the prior 10 milliseconds before the display update. Because it is not averaged over the display update period, it appears less stable than the Tach display due to sensor irregularities or other system dynamic errors.

Note: Codes 41, 42, 43, 45 and 46 may contain numbers larger than 9999. When this occurs, the value is displayed differently. For example, a "10.00." display indicates 10,000 hertz.

42 - AUXILIARY FREQUENCY INPUT

The Auxiliary Frequency Input displays the frequency of this input in hertz (pulses per second). This display is not averaged. It is a 10 millisecond number. See Note above.

43 - FEEDBACK FREQUENCY INPUT

The Feedback Frequency Input displays the feedback input in hertz (pulses per second). The number displayed is not averaged over the display period. It is a 10 millisecond calculated number. See Note above.

44 - DEVIATION (ERROR)

The Deviation display is the difference between the setpoint and the feedback (Ramped Reference (46) - Feedback (43)). It is also a 10 millisecond calculated variable.

45 - SCALED REFERENCE

The Scaled Reference is the scaled setpoint number in hertz. The Scaled Reference is the calculated variable input to the Acceleration/Deceleration routine. See Note on Page C-6.

46 - RAMPED REFERENCE

The Ramped Reference is the calculated output of the Acceleration/Deceleration routine in hertz. The Ramped Reference is the setpoint input to the control algorithm. See Note on Page C-6.

47 - OUTPUT

The Output variable represents the level of the Drive Output to the motor. The Output variable is represented in percent of full output.

48 - TRIM OUTPUT

The Trim Output is the calculated output of the control algorithm. It is equivalent to the total output minus the feedforward {output(47) = Trim Output (48) + Feedforward}. The Trim Output is represented in DAC bits where 4096 equals 100% output, 2048 equals 50% output, etc.

49 - PULSE ERROR COUNT

The Pulse Error Count indicates the difference between the number of External Reference pulses received and the number of Feedback pulses received during the Follower Scaling Mode of operation. It is an indicator of the position error between the lead and follower devices. This error is cleared to zero when the M-Drive enters a stop state.

50 - ACTIVE MODE

The Active Mode is an M-Drive status indicator of the active scaling mode.

- 0 - Direct Mode
- 1 - Master Mode
- 2 - Follower Mode
- 3 - Offset Mode

A description of these modes is available in the Control Parameters - Scaling Mode Control section of the manual.

51 - ENTRY ERRORS

The Entry Errors display can be used to indicate why a keypad entry was not accepted by the M-Drive.

- 0 - No Error
- 1 - Invalid Code
- 2 - Above Maximum Value
- 3 - Below Minimum Value
- 4 - Keypad Lockout
- 5 - Entry Timeout

If an entry is not accepted by the M-Drive, the last valid value is displayed. Code 51 can be used to interrogate why the new value was not accepted.

52 - ALARM STATUS

The Alarm Status display indicates the status of the limits and alarms in the M-Drive. The presence of the number associated with that alarm indicates that alarm is active.

- 1 - Low Limit
- 2 - High Limit
- 3 - Low Alarm
- 4 - High Alarm
- 5 - Error Alarm 1
- 6 - Error Alarm 2
- 7 - Current Limit

53 - CONTROL STATE

The Control State display indicates the control or operating state of the M-Drive.

- 1 - Jog
- 32 - Run
- 64 - Ramped Stop
- 128 - Fast Stop

54 - CONTROL MODE

The Control Mode display indicates the status of the optional switch inputs to the M-Drive. This number is a weighted sum of the numbers associated with the switched inputs. This code, along with code 53, is intended for use by the computer interface. It is available through the keypad for trouble-shooting convenience only.

- 128 - Primary Mode/Secondary Mode
- 64 - Not Used
- 32 - Closed/Open Loop
- 16 - Pri. Setpt. 1/Pri. Setpt. 2
- 8 - Sec. Setpt. 3/Sec. Setpt. 4
- 4 - Local/Computer
- 2 - Keypad Enable/Disable
- 1 - Ramp Enable/Ramp Disable

To decode the display, subtract the highest number from the above list consecutively from the display number.

For example, a display of 178 would be decoded as:

$$\begin{array}{r} 178 \\ -128 \text{ Primary Mode} \\ \hline 50 \\ -32 \text{ Closed Loop} \\ \hline 18 \\ -16 \text{ Primary Setpoint 1} \\ \hline 2 \\ -2 \text{ Keypad Enable} \\ \hline 0 \end{array}$$

Also Secondary Setpoint 4, Computer, Setpoint Hold because these numbers were not subtractable.

55 - A/D INPUT

The A/D Input display indicates the status of the Analog Input. This number is filtered but is not zero and span adjusted.

56 - A/D INPUT - ADJUSTED

This monitor variable displays the status of the Analog Input after the zero and span calculations have been made.

57 - POWER LINE FAILURE

MV- 57 is a counter that is incremented every time the AC line falls below the specified level. It can be used to determine if inductive loads are causing line notches or dips. The count can be reset to zero by pressing the "Clear" key when this variable is accessed.

58 - SERIAL COMMUNICATIONS ERROR

MV-58 displays the communications error code for the last message transmitted to the M-Drive. This code is intended for use by the communications interface, and is a weighted sum of the error code bit pattern:

- 32 Data was out of minimum/maximum range
- 16 Invalid Parameter Code, Checksum or Decimal Point Error
- 8 Receive buffer filled before ETX received or Message Format Error
- 4 Invalid Parameter Data
- 2 Parity error
- 1 M-Drive in Local not Computer Mode
- 0 No errors

To decode the display, subtract the highest number from the list consecutively from the display number.

For example, a display of 37 would be decoded as:

37	
- 32	Data out of minimum/maximum range
5	
- 4	Invalid Parameter Data
1	
- 1	M-Drive in Local not Computer Mode
0	

MV-59: FREQUENCY OVERFLOW

MV-59 is a counter that is incremented every time the frequency inputs to the M-Drive cause an overflow. The count can be reset to zero by pressing the "Clear" key when this variable is accessed.

60 - CURRENT LIMIT RESPONSE

This parameter can be used to adjust the Current Limit response rate. A higher value for CP-60 will reduce the phase angle at a faster rate going into and out of current limit.

61 - PRIMARY SCALING MODE

This parameter selects the scaling format that is used for setpoint calculation when the Primary Scaling mode is switch selected.

- 0 - Direct
- 1 - Master
- 2 - Follower
- 3 - Offset

62 - SECONDARY SCALING MODE

This parameter selects the scaling format that is used for setpoint calculation when the Secondary Scaling Mode is switch selected.

- 0 - Direct
- 1 - Master
- 2 - Follower
- 3 - Offset

63 - PRIMARY DISPLAY MODE

This parameter selects the scaling format that is used for the display calculation when the Primary Scaling Mode is switch selected.

- 1 - Master
- 2 - Follower

64 - SECONDARY DISPLAY MODE

This parameter selects the scaling format that is used for the display calculation when the Secondary Scaling Mode is switch selected.

- 1 - Master
- 2 - Follower

65 -GAIN

Small numbers increase the contribution of the Proportional component (of the PID) except that an entry of "0" eliminates the Gain contribution.

66 - RESET (Integral)

Small numbers increase the contribution of the Integral component (of the PID) except that an entry of "0" eliminates the Reset contribution.

67 - RATE (Derivative)

Small numbers increase the contribution of the Differential component (of the PID) except that an entry of "0" eliminates the Rate contribution.

68 - TRIM AUTHORITY

Trim Authority determines how much of the output is influenced by the Gain, Reset and Rate terms, and how much is determined by feedforward. If it is not possible to achieve stable operation with 100% Trim Authority, reduce this parameter and repeat the tuning procedure.

69 - RATE THRESHOLD

If erratic operation is exhibited only at very low feedback frequencies, the Rate Threshold can be increased slightly. This parameter determines the minimum amount of differential error required before the Rate term influences the control output.

70 - DEVICE ADDRESSES

The M-Drive has a settable physical address from 1 to 32. This is used to separately identify the individual M-Drive units on a multidropped RS422 line. Address references to 0 will globally be accepted by all M-Drive Units.

71 - BAUD RATE

There are six different baud or data rates for the M-Drive:

- 1 = 300 Baud
- 2 = 600 Baud
- 3 = 1200 Baud
- 4 = 2400 Baud
- 5 = 4800 Baud
- 6 = 9600 Baud

72 - CHARACTER FORMAT

The M-Drive accepts 3 different character formats:

- 1 = 8 Data Bits, No Parity, One Stop Bit
- 2 = 7 Data Bits, Even Parity, One Stop Bit
- 3 = 8 Data Bits, No Parity, Two Stop Bits

73 - CONTROL MASK

When the computer control is switch selected, it is possible to allow the computer to control some of the functions associated with the discrete switch inputs. These include:

- 1 = Ramp Enable/Disable
- 4 = Run/R-Stop
- 8 = Secondary Setpoint Select
- 16 = Primary Setpoint Select
- 32 = Closed/Open Loop
- 64 = Not Used
- 128 = Primary/Secondary Control Mode

To delegate control of the selected function to the computer, simply add the associated function number to the total. For example, a value of 36 for code 73 would mean the computer has control of the Closed/Open Loop and the Run/R-Stop functions.

74 - ZERO SPEED LOGIC

CP-74 determines the logic of the zero speed discrete output. If CP-74 = "0", the output is controlled only by the Ramped Reference (MV-46). If CP-74 = "1", the output is controlled by both the Ramped Reference and the Feedback (MV-43).

The direct effects of CP-74 on the output are:

- 0 Output is HIGH whenever the Ramped Ref is "0" and LOW whenever the Ramped Ref is not "0".
- 1 Output is LOW whenever Ramped Ref is not "0", but will not go HIGH until both the Ramped Ref and Feedback are "0". Once HIGH the output will not go LOW until the Ramped Ref is not "0".

75 - PRIMARY MODE POSITIVE OFFSET

CP-75 is the Primary Mode Positive Offset.

Note: Refer to Chapter 8 for a full discussion of CP-75, CP-76, CP-77, and CP-78.

76 - PRIMARY MODE NEGATIVE OFFSET

CP-76 is the Primary Mode Negative Offset.

77 - SECONDARY MODE POSITIVE OFFSET

CP-77 is the Secondary Mode Positive Offset.

78 - SECONDARY MODE NEGATIVE OFFSET

CP-78 is the Secondary Mode Negative Offset.

79 - SETPOINT MASK

CP-79 determines which setpoints are disabled when the keypad is locked out (see Page 3-14). The table below identifies the enable/disable status during a keypad lockout for each valid CP-79 value.

<u>CP-79 Value</u>	<u>Setpoints Enabled</u>	<u>Setpoints Disabled</u>
0	1,2,3,4	None
1	None	1,2,3,4
2	1,3	2,4

80 - ANALOG OUTPUT FUNCTION SELECT

CP-80 allocates the Analog Output to the desired Monitor Variable or Control Parameter. Allocation is accomplished by entering the corresponding code number (CP-xx or MV-xx) for the selected variable into CP-80.

81 - ANALOG OUTPUT RANGE

CP-81 ranges the selected CP-80 variable by determining the value for the selected variable that provides a 100% analog output signal.

82 - ANALOG OUTPUT ZERO

CP-82 is used to zero adjust the Analog Output during calibration. For further details, refer to Chapter 4 (Calibration).

83 - ANALOG OUTPUT SPAN

CP-83 is used to span adjust the Analog Output during calibration. For further details, refer to Chapter 4 (Calibration).

84 - ANALOG INPUT FUNCTION SELECT

CP-84 allocates the Analog Input to the desired function. Allocation is accomplished by entering one of the following codes into CP-84:

<u>Code</u>	<u>Function</u>
0	Analog Input Not Used
1	External Reference Freq. Replacement
2	Feedback Frequency Replacement
3	Offset Frequency Replacement
4	Setpoint 1 Replacement
5	Setpoint 2 Replacement
6	Setpoint 3 Replacement
7	Setpoint 4 Replacement

85 - ANALOG INPUT ZERO

CP-85 is used to zero adjust the Analog Input during calibration. For further details, refer to Chapter 4 (Calibration).

86 - ANALOG INPUT SPAN

CP-86 is used to span adjust the Analog Input during calibration. For further details, refer to Chapter 4 (Calibration).

99 - SOFTWARE CODE REVISION

MV-99 displays the code revision number of the M-Drive's software (EPROM).

00 - SOFTWARE PART NUMBER

MV-00 displays the last four digits of the eight digit part number for the M-Drive's software (EPROM). The first four digits are assumed to be "1000".

NOTES

APPENDIX D - USER'S ACTUAL CODE RECORD D

Column 5 (User Setting) is provided for recording the actual value entered for each Code Type.

CODE TYPE	DESCRIPTION	MIN	MAX	USER SETTING	UNITS
01-CP	Primary Setpoint 1	0000	9999	_____	ENG.
02-CP	Primary Setpoint 2	0000	9999	_____	ENG.
03-CP	Secondary Setpoint 1	0000	9999	_____	ENG.
04-CP	Secondary Setpoint 2	0000	9999	_____	ENG.
05-CP	Jog Setpoint	0000	9999	_____	RPM
06-CP	Output Setpoint	-100	+100	_____	%
10-CP	Minimum Limit	0000	9999	_____	RPM
11-CP	Maximum Limit	0000	9999	_____	RPM
12-CP	Low Alarm	0000	9999	_____	RPM
13-CP	High Alarm	0000	9999	_____	RPM
14-CP	Error Alarm 1	0000	9999	_____	RPM
15-CP	Error Alarm 2	0000	9999	_____	RPM
16-CP	Acceleration Time	000.0	600.0	_____	SEC
17-CP	Deceleration Time	000.0	600.0	_____	SEC
18-CP	Lag Pulse Limit	0	9999	_____	PULSES
19-CP	Lead Pulse Limit	0	9999	_____	PULSES
20-CP	Eng. Units-Pri.Sp.	0.000	9999	_____	ENG.
21-CP	Eng. Units-Sec.Sp.	0.000	9999	_____	ENG.
22-CP	Eng. Units-Pri.Dsp.	0.000	9999	_____	ENG.
23-CP	Eng. Units-Sec.Dsp.	0.000	9999	_____	ENG.
29-CP	Recovery Multiplier	0	100	_____	-
30-CP	PPR-Ext. Reference	1	9999	_____	PPR
31-CP	PPR-Feedback	1	9999	_____	PPR
32-CP	PPR-Auxiliary	1	9999	_____	PPR
33-CP	RPM-Ref.-Primary Max	1	9999	_____	RPM
34-CP	RPM-Fdbk.-Primary Max	1	9999	_____	RPM
35-CP	RPM-Aux.-Primary Max	1	9999	_____	RPM
36-CP	RPM-Ref.-Secondary Max	1	9999	_____	RPM
37-CP	RPM-Fdbk.-Secondary Max	1	9999	_____	RPM
38-CP	RPM-Aux.-Secondary Max	1	9999	_____	RPM
60-CP	Current Limit Response	0	50	_____	CODED
61-CP	Scaling Mode-Pri.	0	3	_____	CODED
62-CP	Scaling Mode-Sec.	0	3	_____	CODED
63-CP	Display Mode-Pri.	1	2	_____	CODED
64-CP	Display Mode-Sec.	1	2	_____	CODED
65-CP	Gain	0	9999	_____	-
66-CP	Reset	0	9999	_____	-
67-CP	Rate	0	9999	_____	-
68-CP	Trim Authority	0	100	_____	%
69-CP	Rate Threshold	0	100	_____	HZ
70-CP	Device Address	1	32	_____	-
71-CP	Baud Rate	1	6	_____	CODED
72-CP	Character Format	1	3	_____	CODED
73-CP	Control Mask	0	255	_____	CODED
74-CP	Zero Speed Logic	0	1	_____	CODED
75-CP	Positive Offset, Pri.	0	9999	_____	HZ
76-CP	Negative Offset, Pri.	0	9999	_____	HZ
77-CP	Positive Offset, Sec.	0	9999	_____	HZ

CODE-TYPE	DESCRIPTION	MIN	MAX	USER SETTING	UNITS
78-CP	Negative Offset, Sec.	0	9999	_____	HZ
79-CP	Setpoint Mask	0	2	_____	CODED
80-CP	Analog Output Allocat.	0	99	_____	CODED
81-CP	Analog Output Range	0	9999	_____	CODED
82-CP	Analog Output Zero	0	2048	_____	CODED
83-CP	Analog Output Span	2048	4095	_____	CODED
84-CP	Analog Input Allocat.	0	7	_____	CODED
85-CP	Analog Input Zero	0	2048	_____	CODED
86-CP	Analog Input Span	2048	4095	_____	CODED

APPENDIX E: CODE LIST QUICK REFERENCE E

CODE TYPE	DESCRIPTION	MIN	MAX	DEFAULT	UNITS
01-CP	Primary Setpoint 1	0000	9999	0000	ENG.
02-CP	Primary Setpoint 2	0000	9999	0000	ENG.
03-CP	Secondary Setpoint 1	0000	9999	0000	ENG.
04-CP	Secondary Setpoint 2	0000	9999	0000	ENG.
05-CP	Jog Setpoint	0000	9999	50	RPM
06-CP	Output Setpoint	-100	+100	0	%
10-CP	Minimum Limit	0000	9999	0000	RPM
11-CP	Maximum Limit	0000	9999	2000	RPM
12-CP	Low Alarm	0000	9999	0000	RPM
13-CP	High Alarm	0000	9999	2000	RPM
14-CP	Error Alarm 1	0000	9999	2000	RPM
15-CP	Error Alarm 2	0000	9999	2000	RPM
16-CP	Acceleration Time	000.0	600.0	5.0	SEC
17-CP	Deceleration Time	000.0	600.0	5.0	SEC
18-CP	Lag Pulse Limit	0	9999	0	PULSES
19-CP	Lead Pulse Limit	0	9999	0	PULSES
20-CP	Eng. Units-Pri.Sp.	0.000	9999	2000	ENG.
21-CP	Eng. Units-Sec.Sp.	0.000	9999	1.000	ENG.
22-CP	Eng. Units-Pri.Dsp.	0.000	9999	2000	ENG.
23-CP	Eng. Units-Sec.Dsp.	0.000	9999	1.000	ENG.
29-CP	Recovery Multiplier	0	100	0	—
30-CP	PPR-Ext. Reference	1	9999	60	PPR
31-CP	PPR-Feedback	1	9999	60	PPR
32-CP	PPR-Auxiliary	1	9999	60	PPR
33-CP	RPM-Ref.-Primary Max	1	9999	2000	RPM
34-CP	RPM-Fdbk.-Primary Max	1	9999	2000	RPM
35-CP	RPM-Aux.-Primary Max	1	9999	2000	RPM
36-CP	RPM-Ref.-Secondary Max	1	9999	2000	RPM
37-CP	RPM-Fdbk.-Secondary Max	1	9999	2000	RPM
38-CP	RPM-Aux.-Secondary Max	1	9999	2000	RPM
40-MV	Tach	0	9999	—	ENG.
41-MV	External Reference	0	9999	—	HZ
42-MV	Auxiliary Input	0	9999	—	HZ
43-MV	Feedback	0	9999	—	HZ
44-MV	Deviation	0	9999	—	HZ
45-MV	Scaled Reference	0	9999	—	HZ
46-MV	Ramped Reference	0	9999	—	HZ
47-MV	Output	-100	+100	—	%
48-MV	Trim Output	-4096	+4096	—	BITS
49-MV	Pulse Error Count	-9999	9999	—	PULSES
50-MV	Active Mode	0	3	—	CODED
51-MV	Entry Errors	0	5	—	CODED
52-MV	Alarm Status	0	6	—	CODED
53-MV	Control State	0	128	—	CODED
54-MV	Control Mode	0	255	—	CODED
55-MV	A/D Input	0	4095	—	CODED
56-MV	A/D Input-Adjusted	0	4095	—	CODED
57-MV	Power Line Failure	0	9999	—	COUNTS
58-MV	Communications Error	0	63	—	CODED
59-MV	Frequency Overflow	0	9999	—	COUNTS
60-CP	Current Limit Response	0	50	20	CODED

CODE TYPE	DESCRIPTION	MIN	MAX	DEFAULT	UNITS
61-CP	Scaling Mode-Pri.	0	3	1	CODED
62-CP	Scaling Mode-Sec.	0	3	2	CODED
63-CP	Display Mode-Pri.	1	2	1	CODED
64-CP	Display Mode-Sec.	1	2	2	CODED
65-CP	Gain	0	9999	9000	—
66-CP	Reset	0	9999	2000	—
67-CP	Rate	0	9999	9000	—
68-CP	Trim Authority	0	100	100	%
69-CP	Rate Threshold	0	100	10	HZ
70-CP	Device Address	1	32	1	—
71-CP	Baud Rate	1	6	6	CODED
72-CP	Character Format	1	3	2	CODED
73-CP	Control Mask	0	255	0	CODED
74-CP	Zero Speed Logic	0	1	0	CODED
75-CP	Positive Offset, Pri.	0	9999	0	HZ
76-CP	Negative Offset, Pri.	0	9999	0	HZ
77-CP	Positive Offset, Sec.	0	9999	0	HZ
78-CP	Negative Offset, Sec.	0	9999	0	HZ
79-CP	Setpoint Mask	0	2	2	CODED
80-CP	Analog Output Alloc.	0	99	98	CODED
81-CP	Analog Output Range	0	9999	2000	CODED
82-CP	Analog Output Zero	0	2048	998	CODED
83-CP	Analog Output Span	2048	4095	3906	CODED
84-CP	Analog Input Allocat.	0	7	0	CODED
85-CP	Analog Input Zero	0	2048	0	BITS
86-CP	Analog Input Span	2048	4095	3900	BITS
99-MV	Software Code Rev	-----	-----	-----	REV
00-MV	Software Part Number	-----	-----	-----	NUMBER

APPENDIX F: M-DRIVE PIN OUT

F

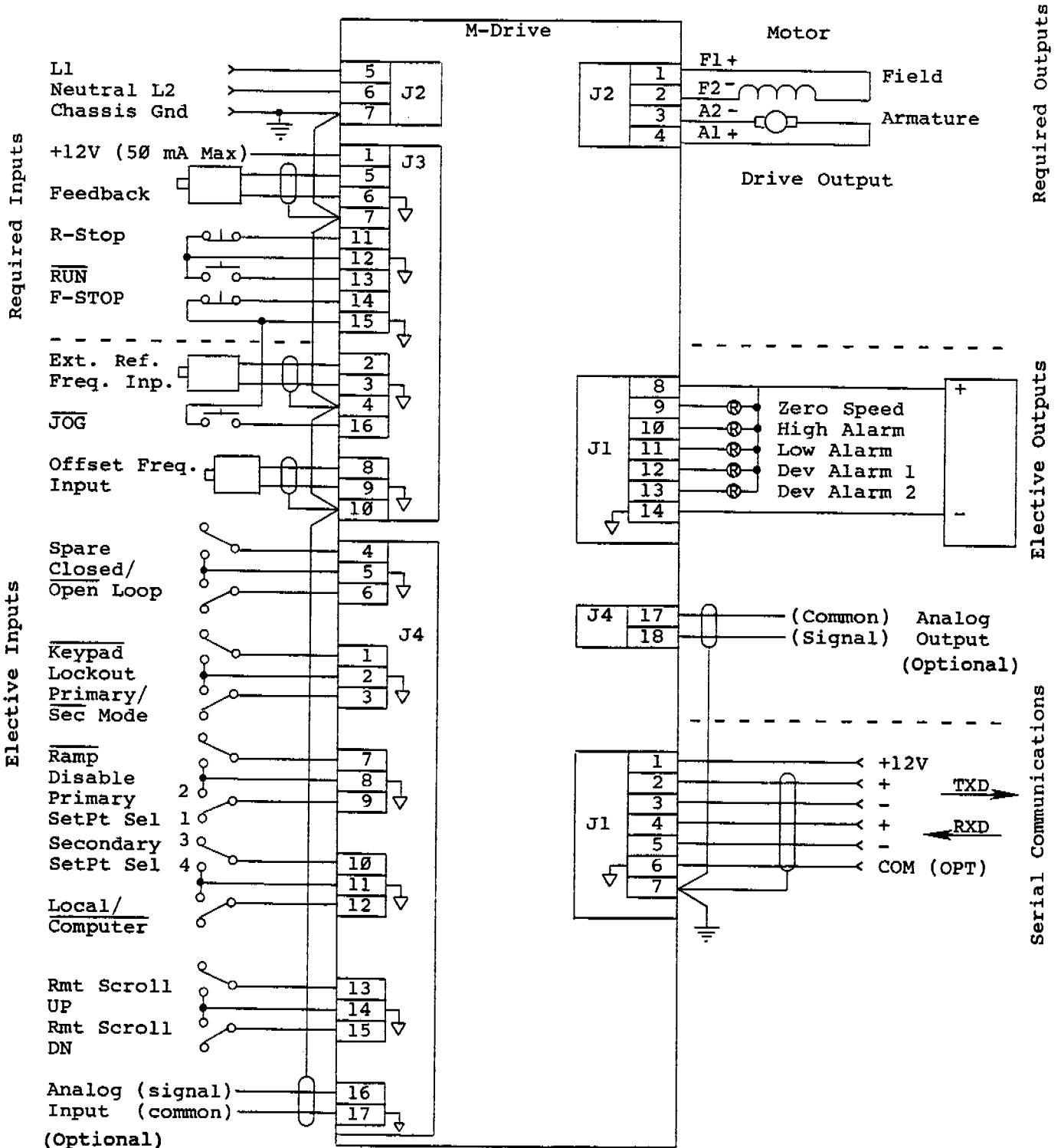

Figure F-1: M-Drive General Wiring Diagram

NOTES

APPENDIX G: TYPICAL WIRING DIAGRAMS

G

WARNING

This diagram is intended for conceptual purposes only. The user is responsible for providing all necessary safety equipment and corresponding wiring connections necessary to prevent bodily injury in all modes of operation.

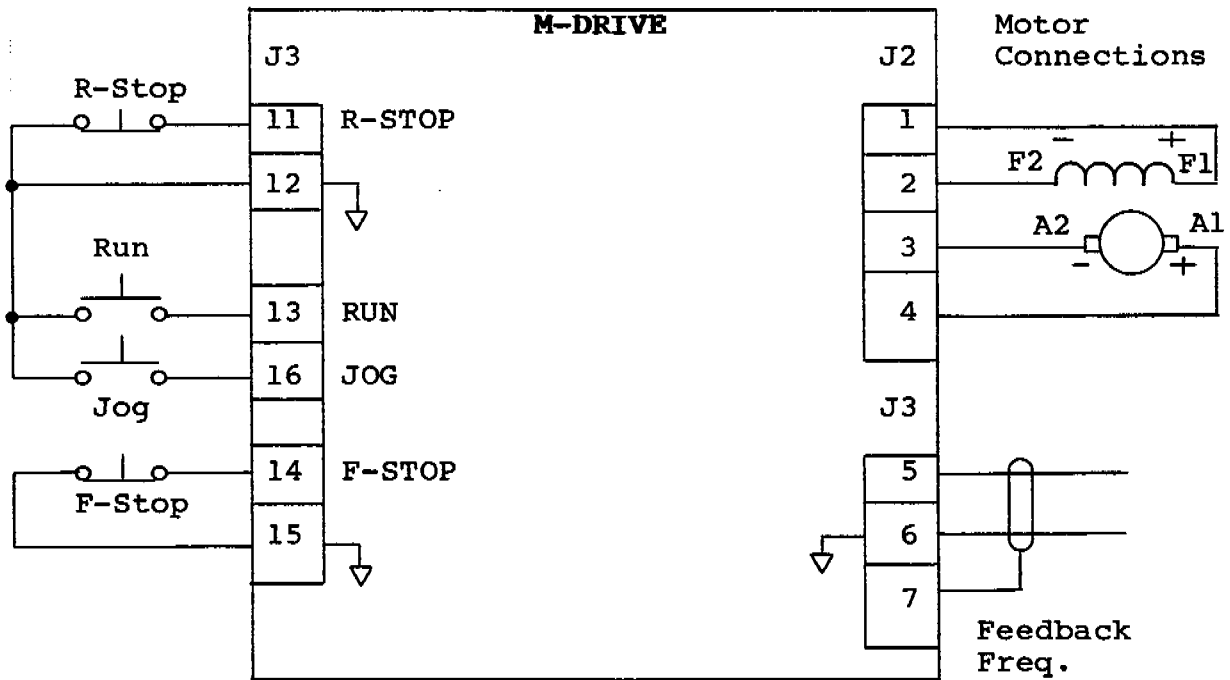

Figure G-1: M-Drive Wiring Connections without Relays

WARNING

This diagram is intended for conceptual purposes only. The user is responsible for providing all necessary safety equipment and corresponding wiring connections necessary to prevent bodily injury in all modes of operation.

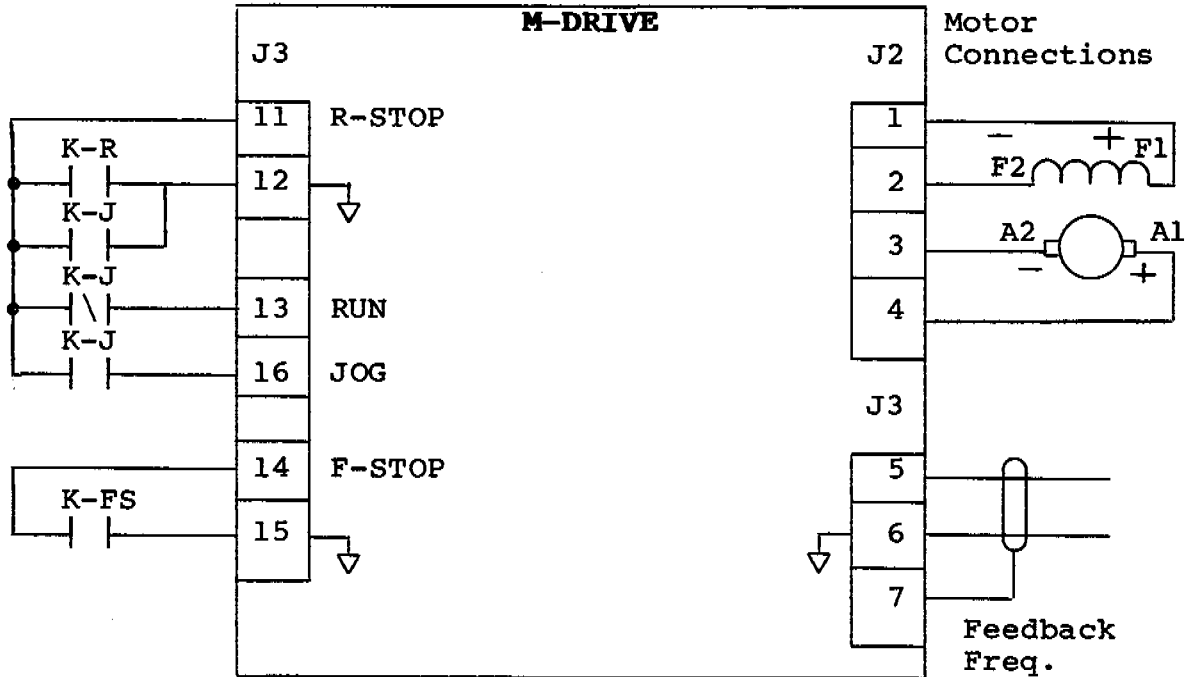
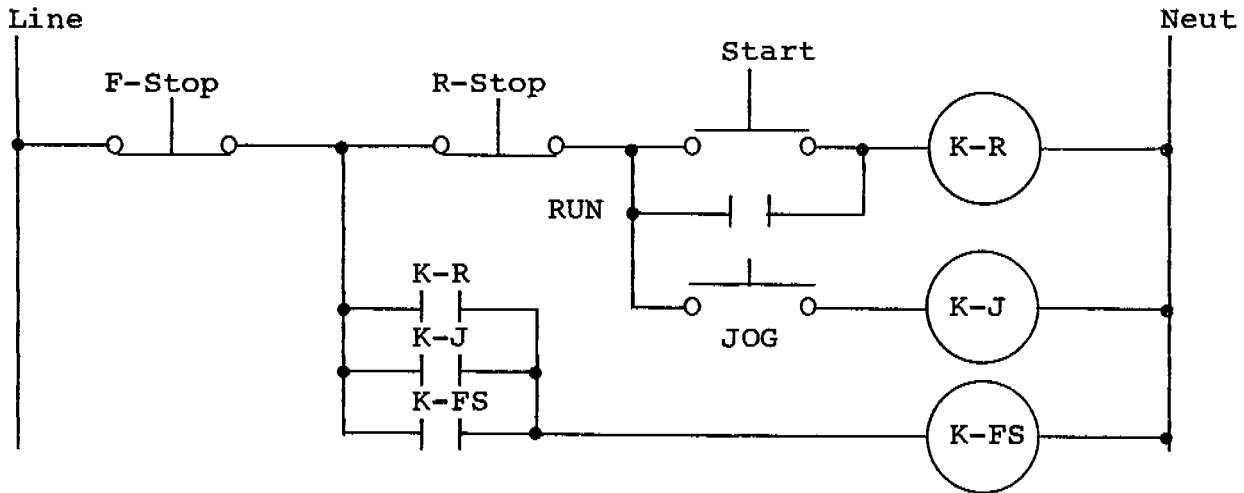

Figure G-2: Relay Start & Stop Wiring Connections

WARNING

This diagram is intended for conceptual purposes only. The user is responsible for providing all necessary safety equipment and corresponding wiring connections necessary to prevent bodily injury in all modes of operation.

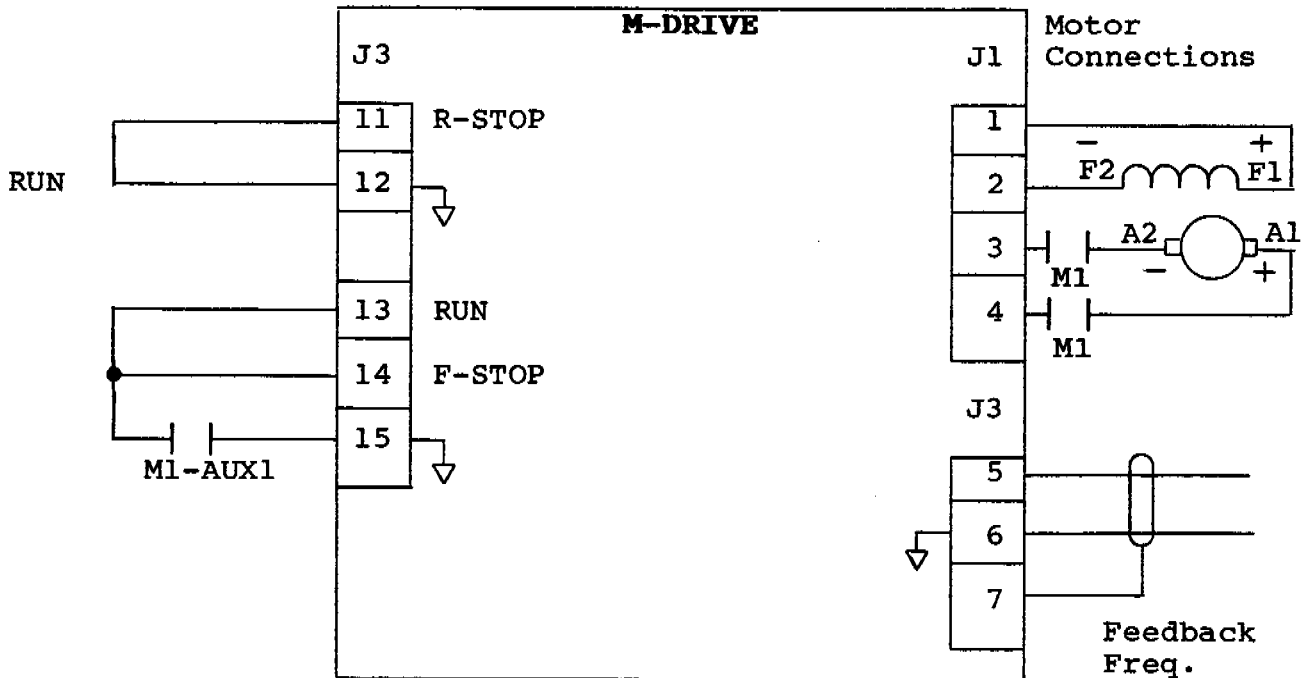
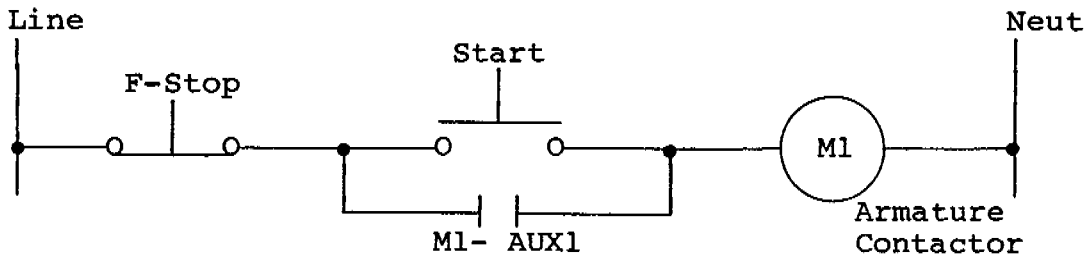
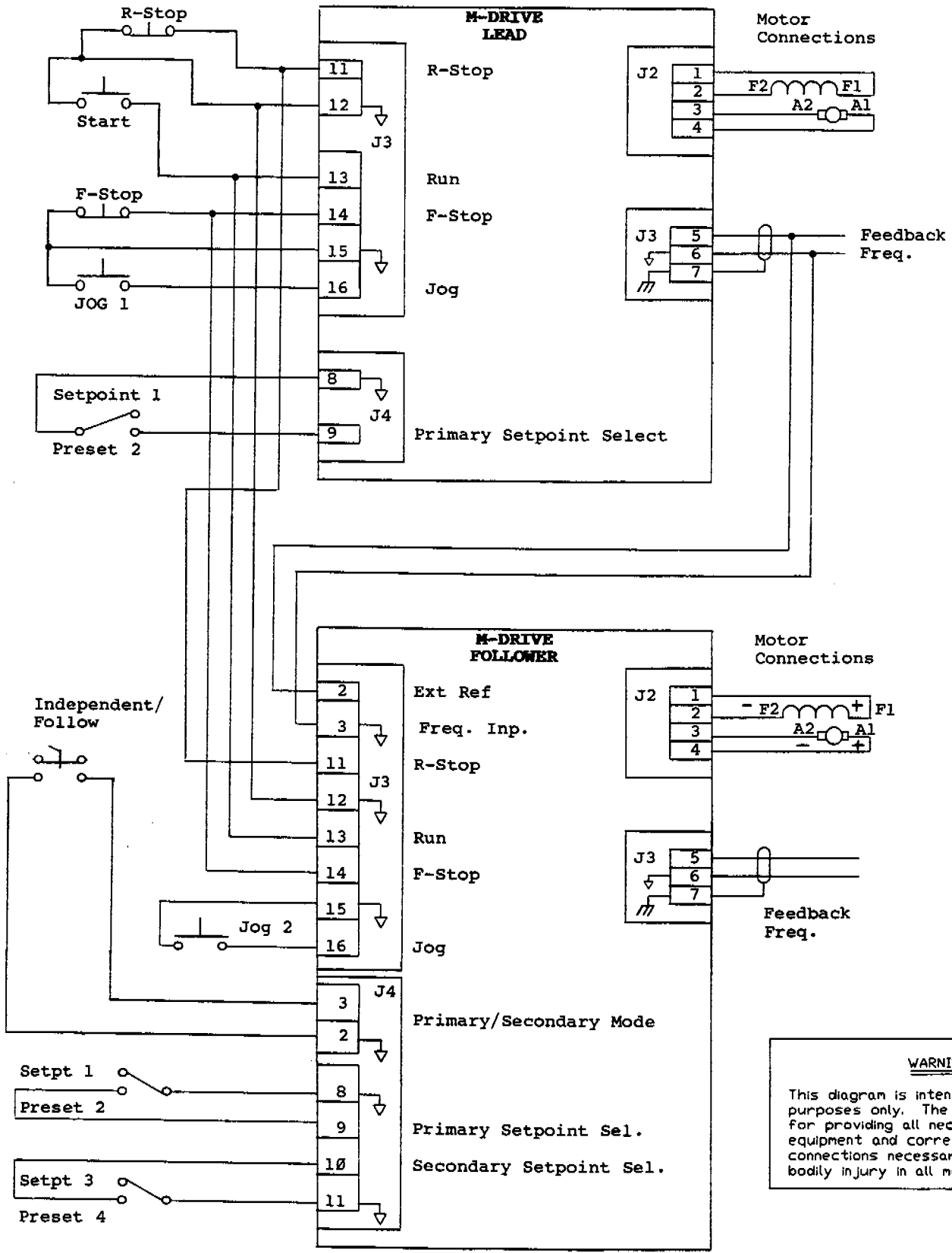

Figure G-3: Start/Stop with Armature Contactor



WARNING

This diagram is intended for conceptual purposes only. The user is responsible for providing all necessary safety equipment and corresponding wiring connections necessary to prevent bodily injury in all modes of operation.

Figure G-4: Two Channel Start/Stop - Lead/Follower Logic

APPENDIX H: PROGRAMMING AIDE

H

This appendix identifies which CP- Programming Codes are required for specific formats and modes. When applicable, if a specific value is required for a Programming Code, that value is indicated via an "=" sign. (For example, CP-61 = 1.)

For each listed item, CP- codes are listed for both Primary and Secondary Modes (columns 2 and 3). Note that all formats require setpoint entries.

CONTROL CODES

ITEM	PRIMARY	SECONDARY
Setpoints	CP-1, CP-2	CP-3, CP-4
<u>Master Format</u>		
	CP-61 = 1	CP-62 = 1
PPR Feedback	CP-31	CP-31
RPM Feedback Max	CP-34	CP-37
Engineering Units	CP-20	CP-21
<u>Follower Format</u>		
	CP-61 = 2	CP-62 = 2
PPR Feedback	CP-31	CP-31
PPR External Ref.	CP-30	CP-30
RPM Feedback Max	CP-34	CP-37
RPM External Ref Max	CP-33	CP-36
Engineering Units	CP-20	CP-21
<u>Offset Format</u>		
	CP-61 = 3	CP-62 = 3
PPR Feedback	CP-31	CP-31
PPR External Ref.	CP-30	CP-30
PPR Auxiliary Ref	CP-32	CP-32
RPM Feedback Max	CP-34	CP-37
RPM External Ref Max	CP-33	CP-36
RPM Aux. Ref. Max	CP-35	CP-38
+ Offset	CP-75	CP-77
- Offset	CP-76	CP-78
Engineering Units	CP-20	CP-21
<u>With Analog Input</u>	CP-84 = 3	CP-84 = 3

TACH CODES

ITEM	PRIMARY	SECONDARY
<u>Speed</u>		
	CP-63 = 1	CP-64 = 1
PPR Feedback	CP-31	CP-31
RPM Feedback Max	CP-34	CP-37
Engineering Units	CP-22	CP-23
<u>Ratio</u>		
	CP-63 = 2	CP-64 = 2
PPR Feedback	CP-31	CP-31
PPR External Ref.	CP-30	CP-30
RPM Feedback Max	CP-34	CP-37
RPM External Ref Max	CP-33	CP-36
Engineering Units	CP-22	CP-23

APPENDIX I

I

USA Standard Code for Information Interchange

I. Scope

This coded character set is to be used for the general interchange of information among information processing systems, communication systems, and associated equipment.

2. Standard Code

Bits					0 0 0	0 0 1	0 1 0	0 1 1	1 0 0	1 0 1	1 1 0	1 1 1	
b ₇	b ₆	b ₅	b ₄	b ₃	COLUMN								
			b ₂	b ₁	ROW	0	1	2	3	4	5	6	7
0	0	0	0	0	0	NUL	DLE	SP	0	⊙	P	`	p
0	0	0	1	1	1	SOH	DC1	!	1	A	Q	a	q
0	0	1	0	0	2	STX	DC2	"	2	B	R	b	r
0	0	1	1	1	3	ETX	DC3	#	3	C	S	c	s
0	1	0	0	0	4	EOT	DC4	\$	4	D	T	d	t
0	1	0	1	1	5	ENQ	NAK	%	5	E	U	e	u
0	1	1	0	0	6	ACK	SYN	&	6	F	V	f	v
0	1	1	1	1	7	BEL	ETB	'	7	G	W	g	w
1	0	0	0	0	8	BS	CAN	(8	H	X	h	x
1	0	0	1	1	9	HT	EM)	9	I	Y	i	y
1	0	1	0	0	10	LF	SUB	*	:	J	Z	j	z
1	0	1	1	1	11	VT	ESC	+	;	K	[k	{
1	1	0	0	0	12	FF	FS	,	<	L	\	l	
1	1	0	1	1	13	CR	GS	-	=	M]	m	}
1	1	1	0	0	14	SO	RS	.	>	N	^	n	~
1	1	1	1	1	15	SI	US	/	?	O	_	o	DEL

NOTES

Auxiliary Reference: A frequency input used by the M-Drive when it is necessary to control motor speed by more than one process variable. (Chapter 8)

Caution: A method to denote a procedure or task which may result in equipment damage if performed incorrectly. Compare with Note and Warning.

Closed/Open Loop: A digital input which determines whether or not the M-Drive adjusts the speed command to bring the difference between the actual feedback and the ideal feedback to zero (Closed Loop) or ignores the feedback (open loop). (3-11)

Direct Format: A motor control format where all scaling and feedback conditions are ignored, which thereby allows the operator to directly control the M-Drive output. Typically used for System trouble-shooting. (8-2)

Error Alarm 1 (Ramped Error): A digital output used to indicate when the speed error (Ramped Reference minus feedback) is at or outside a band specified by the operator. (3-17)

Error Alarm 2 (Scaled Error): A digital output used to indicate when the speed error (Scaled Reference minus feedback) is at or outside a band specified by the operator. (3-17)

External Reference: A frequency input that acts as the lead signal when the M-Drive is in Follower or Offset Format. (3-10)

F-STOP: (Fast Stop) One of four M-Drive states. In the F-Stop state, the M-Drive ignores the specified DECEL rate and immediately brings the speed command to zero. Compare with RUN, JOG and R-STOP. (3-9)

Feedback Input: A pulse train input used by the M-Drive to ascertain motor speed. (3-7)

Format: Any of several algorithms used to calculate the Scaled Reference or Tach readout.

Follower Format: The most commonly used speed control algorithm. The speed is determined by and is directly proportional to two variables: The Ratio setpoint and the External Reference Frequency. (1-4, 5-4, 5-9)

High Alarm: An output used to indicate when the motor speed equals or exceeds the High Alarm level. (3-17)

JOG: One of four M-Drive states. In the JOG state, the M-Drive rotates the subject motor at the RPM entered for the JOG setpoint. Compare to RUN, R-STOP and F-STOP. (3-10)

Keypad Lockout: A digital input used to disable portions of the front keypad. (3-13)

Local/Computer: A digital input used to enable the serial communications port to permit changes in CP-xx values or control operation. (3-14)

Low Alarm: An output used to indicate when the motor speed is at or below the Low Alarm level. (3-17)

Master Format: The simplest generally used speed control algorithm. The speed is determined by and is directly proportional to only one variable: The Setpoint. (1-3, 5-3)

Mode: Either of two complete programs, consisting of a preselected format, a pair of setpoints and a set of system constants and used by the M-Drive to control the motor.

Offset Format: The most complex speed control algorithm. The speed is determined by three variables: the Ratio Setpoint, the External Reference Frequency and the Auxiliary Reference Frequency. (8-3)

Note: A method to denote additional attention to a procedure or task. Compare with Caution and Warning.

Primary Mode: The default mode, active whenever J4 Pin 3 is not shorted to common. The Primary Mode uses the Primary group of system constants, the format specified by CP-61 and has access to setpoints one and two. The particular setpoint is use depends on the voltage on J4 Pin 9, Primary Setpoint Select. (5-3)

Primary/Secondary Scaling Mode: A digital input which determines which format, which system constants, and which setpoint pair are active at any one time. (3-12, 5-3)

Primary Setpoint Select: A digital input which determines whether the setpoint is obtained from CP-01 or CP-02. (3-12)

Ramp Disable: A digital input used to arrest or freeze the accel or decel ramp at its existing value for the duration of the input closure. (3-13)

Ring Kits: Any of several gear, magnetic sensor and mounting ring combinations assembled under one part number and used to generate a zero crossing pulse train. Ordinarily used to provide feedback from a rotating shaft (A-1).

R-STOP: (Ramp Stop) One of four M-Drive states. In the R-Stop state, the M-Drive decreases the speed command to zero using the specified DECEL rate. Compare to RUN, JOG and F-STOP. (1-6, 3-8)

RUN: One of four M-Drive states. In the RUN state, the M-Drive rotates the subject motor at the RPM called for as determined by the setpoints and the operative scaling format. Compare to JOG, R-STOP and F-STOP. (1-6, 3-8)

Secondary Mode: The mode in use whenever J4 Pin 3 is shorted to common. The Secondary Mode uses the Secondary group of system constants, the format specified by CP-62 and has access to setpoints three and four. The particular setpoint is use depends on the voltage on J4 Pin 10, Secondary Setpoint Select. (5-3)

Secondary Setpoint Select: A digital input which determines whether the setpoint is obtained from CP-03 or CP-04. (3-12)

Warning: A method to denote a procedure or task which may result in bodily injury or death if performed incorrectly. Compare with Note and Caution.

Zero Speed: A digital output which indicates whether or not the motor should be moving. (3-17)

NOTES

service policy

Contrex, Inc., recognizes that with each sale of its product there are certain product obligations. This document defines the limits of such obligations and provides guidelines for the performance of related services.

Applicability

This Service Policy shall apply to all product sales of Contrex, Inc. However, it may be modified by mutual consent. Thus, whenever an accepted proposal contains wording inconsistent with this policy, the proposal will prevail with respect to specific sale or series of sales involved.

Applicability of this policy is also somewhat limited in cases where products are sold to an OEM for resale to user. See paragraph below entitled *OEM Service*.

Service Personnel

Contrex, Inc., has a staff whose primary responsibility is service - both factory service and field (on-site) service. Personnel of this department are usually available for service on a 24 hour notice. To facilitate quicker handling of service requests, either written or by phone, such requests should be directed to the Contrex, Inc., Technical Services Department.

Service Charges

Contrex, Inc., reserves the right to charge for all services performed at the customers request with the exception of factory service performed under warranty. All on-site service is charged at flat-rate per diem rates plus expenses. Any Contrex, Inc., product developing defects as defined in the warranty during its effective period will be repaired or replaced without charge, providing it is shipped, prepaid, to Contrex, Inc., 8900 Zachary Lane North, Maple Grove, Minnesota 55369.

Spare Parts

Contrex, Inc., will usually have an adequate inventory of spare parts and circuit boards for all standard products. However, purchasers are encouraged to maintain a nominal supply of spare parts to insure immediate on-site accessibility.

Instruction Manuals

Instructions for installation, maintenance and troubleshooting are included in manuals that are provided with the equipment. Repairs may be performed in the field by competent customer personnel; but in order to not invalidate the warranty they must be made in strict accordance with published instructions, and **ONLY AFTER** obtaining approval of the Technical Service Department (such repairs are usually limited to the replacement of circuit boards and major subassemblies, not the repair of these items).

OEM Service

In many instances Contrex, Inc., products are sold to the original equipment manufactures or integrators for inclusion in larger systems. In such cases the obligations of Contrex, Inc., extend only to that original purchaser. It is the latter's responsibility to handle any service required by his customer, the end user. Such problems can usually be solved by field replacement of complete units. OEM's are encouraged to buy and maintain a supply of "loaners" for this purpose. Contrex, Inc., will provide factory overhaul service at nominal charges to support that OEM. Users of Contrex, Inc., products that were acquired as components of larger systems may buy service or spare parts directly from Contrex, Inc., at standard prices, but they must appeal through the OEM for warranty service.

If Contrex, Inc., encounters trouble in the field which appears to be the result of fault or inadequacy of the system, Contrex, Inc., reserves the right to recover service charges from the party that authorized the service activity.



warranty

Contrex, Inc., guarantees this device against defects in workmanship and materials for a period of one (1) year from the date of purchase. Any parts or components that fail during the warranty period will be replaced or repaired without charge. This guarantee is void if the device has been damaged by improper installation or operation, tampering, careless handling or accident.

When a device fails to function in accordance with standards set forth in the instruction manual, the purchaser should contact an authorized representative of Contrex, Inc., 8900 Zachary Lane North, Maple Grove, Minnesota 55369. Whether repairs will take place in the field or at the factory will be solely the prerogative of Contrex, Inc.

If inspection reveals defects that are caused by faulty materials or workmanship, Contrex, Inc., reserves the right to either replace the device or rebuild the device using new or refurbished warranted parts and components. In either instance, the device that is returned to the purchaser meets full factory standards for new device performance. If there is less than 90 days remaining on the warranty period at the time of the repair, the warranty will extend to 90 days after the repair.

Parts and services outside the scope of this warranty will be available at Contrex, Inc., current market price.

Contrex's liability for a device or its use, whether in warranty or not, shall not in any instance exceed the cost of correcting the defects of the device. Contrex, Inc., assumes no responsibility for damage to property or injuries to persons from improper use of this device.

No express warranties and no implied warranties whether of merchantability or otherwise (except as to title), other than those set forth above, which are expressly made in lieu of all other warranties, shall apply to any device sold by Contrex, Inc.

Contrex, Inc., reserves the right to change or improve its devices without imposing any obligation upon Contrex, Inc., to make changes or improvements in previously manufactured devices.

This warranty statement is a summary of Contrex, Inc's policy. Further limits of liability are contained in the Contrex, Inc's purchase order acknowledgments and invoices.



Contrex, Inc.
8900 Zachary Lane North, Maple Grove, MN 55369 USA
Phone (763) 424-7800 Fax (763) 424-8734