

# 14 Series Granulators

Models 1418, 1424, 1436 and 1448





Please record your equipment's model and serial number(s) and the date you received it in the spaces provided.

It's a good idea to record the model and serial number(s) of your equipment and the date you received it in the User Guide. Our service department uses this information, along with the manual number, to provide help for the specific equipment you installed.

Please keep this User Guide and all manuals, engineering prints and parts lists together for documentation of your equipment.

Date:

Manual Number: UGG055-0517

Serial Number(s):

Model Number(s):

**DISCLAIMER:** Conair shall not be liable for errors contained in this User Guide or for incidental, consequential damages in connection with the furnishing, performance or use of this information. Conair makes no warranty of any kind with regard to this information, including, but not limited to the implied warranties of merchantability and fitness for a particular purpose.

**Introduction**



**DANGER! Read the instruction manual before installing and operating the machine.**

This instruction manual contains instructions how to install, operate and maintain the standard versions of the Conair 14 Series, Model number 1418, 1424, 1436 and 1448, along with additional options suffix (see suffix key below) -K, -U, -B, -RF. This manual also includes information on the optional wear kit and hardened chamber model and the economical Solo model.

The performance of your supplied machine may vary from the standard machines described in this instruction manual. If there are any questions, please contact Conair's local distributor or Conair's main office.

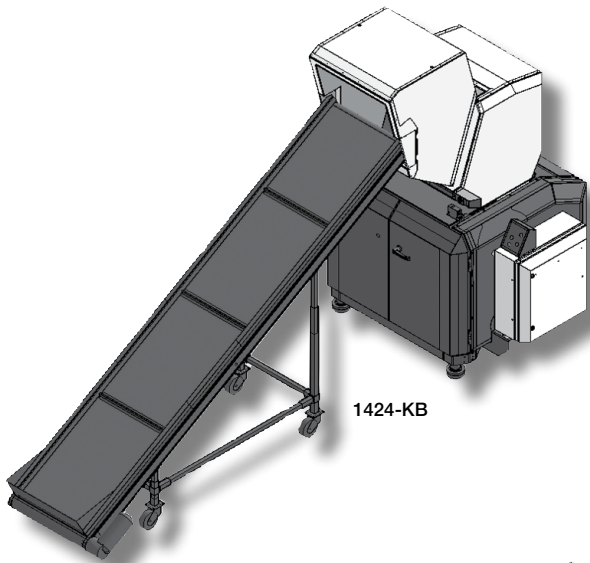

1424-KB

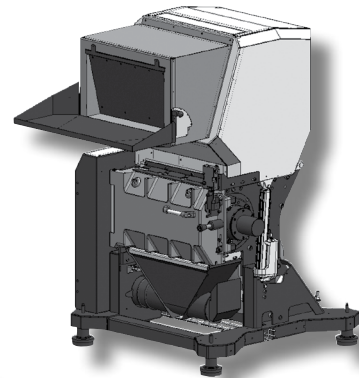

1424

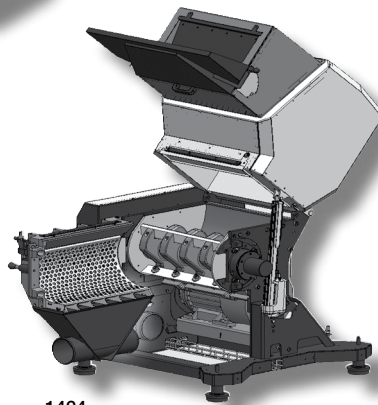

1424

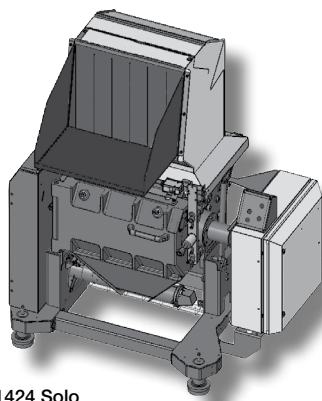

1424 Solo

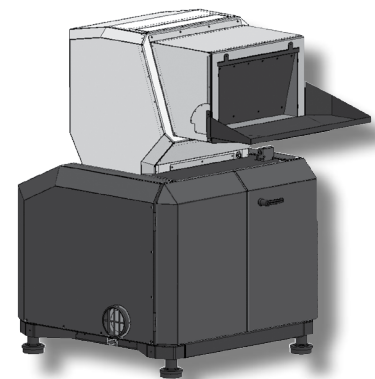

1424-K

**Head office:**

The Conair Group  
200 West Kensinger Drive

Cranberry Twp., PA 16066

Phone: 724.584.5500

Instant Access 24/7 (Parts and Service): 800.458.1960

Website: [www.conairgroup.com](http://www.conairgroup.com)

E-mail: [info@conairgroup.com](mailto:info@conairgroup.com)

**Suffix Key:**

K = Sound Enclosure

U = Blower discharge

B = Band conveyor

P = Pipe / profile

RF = Roll feed

## 1. SAFETY RULES

<b>General rules, Safety.....</b>	<b>1:1</b>
Warning signs on the machine .....	1:1
Warnings in the instruction manual .....	1:1
Safety rules, During Installing .....	1:2
Safety rules, During start and operation .....	1:2
Safety rules, During service.....	1:3
<b>Risk of machinery damage.....</b>	<b>1:3</b>

## 2. DESCRIPTION

<b>Technical specifications .....</b>	<b>2:1</b>
General Data, Supplied machine: .....	2:1
General Data, 14 Series: .....	2:1
Personnel responsible for the machine .....	2:1
Overview.....	2:2
<b>Layout .....</b>	<b>2:3</b>
1424 Hopper front .....	2:3
1424-K Hopper front .....	2:3
1424-K Band conveyor front .....	2:4
1424-KU Hopper front .....	2:4
1424 Hopper front Solo .....	2:5
1424-B Band conveyor front Solo.....	2:5
<b>Function .....</b>	<b>2:6</b>
CONAIR 14 Series .....	2:6
Additional suffix 1418, 1424, 1436 and 1448 ...	2:6
Additional suffix Solo.....	2:6
Additional suffix Standard.....	2:6
Additional suffix High wear package .....	2:6
Additional suffix -K.....	2:7
Additional suffix -U.....	2:7
Additional suffix -B.....	2:7
Additional suffix -P.....	2:7
Additional suffix -RF.....	2:7
Additional suffix -AX.....	2:7
Additional suffix -DS, -TRACS, -TP .....	2:7
<b>Rotor .....</b>	<b>2:8</b>
General rules, Rotor.....	2:8
3-blade, rotor.....	2:8
5-blade, rotor.....	2:8
<b>Rotating knives.....</b>	<b>2:8</b>
<b>Cutter housing.....</b>	<b>2:9</b>
General rules, Cutter housing .....	2:9
Cutter housing 1st.....	2:9
Cutter housing 5th.....	2:9
<b>Fixed knives.....</b>	<b>2:9</b>
Knife grinding fixture .....	2:10
Knife clearance .....	2:10
Knife setting fixture.....	2:10

## 2. DESCRIPTION

<b>Transmission.....</b>	<b>2:11</b>
Motor .....	2:11
Drive belt, Motor pulley, Rotor pulley .....	2:11
Flywheel .....	2:11
<b>Safety equipment.....</b>	<b>2:12</b>
General rules, Safety equipment.....	2:12
Safety equipment .....	2:13
Inlet, Hopper .....	2:13
Flap(s) .....	2:13
Screen, Screen box.....	2:13
Granule bin .....	2:13
Main switch .....	2:14
Emergency stop(s) .....	2:14
Key to electrical cabinet .....	2:14
Stand still monitor.....	2:14
Safety switch.....	2:15
Star knob.....	2:15
Magnet switch.....	2:15
Safety relay .....	2:16
<b>Overload protection .....</b>	<b>2:16</b>
General rules, Overload protection.....	2:16
Overload protection .....	2:16
<b>Operating panel.....</b>	<b>2:16</b>
<b>Level switch .....</b>	<b>2:17</b>
General rules, Level switch .....	2:17
Level switch, Paddle type .....	2:17
<b>Hours counter.....</b>	<b>2:17</b>
<b>Current relay .....</b>	<b>2:18</b>
General rules, Current relay.....	2:18
Limit value ( LVA, LV%) .....	2:18
Hysteresis ( HA, H%).....	2:18
Reaction time (T1).....	2:19
Time delay during start up (T2).....	2:19
Yellow LED .....	2:19
Green LED.....	2:19
Function setting (FS) .....	2:19
<b>Specifications .....</b>	<b>2:20</b>

## 3. TRANSPORT / LIFT / STORE

<b>Transport / Lift.....</b>	<b>3:1</b>
<b>Store the granulator.....</b>	<b>3:1</b>

## 4. INSTALLING

<b>Before first start</b> .....	<b>4:1</b>
General rules, Installing.....	4:1
Reception inspection.....	4:1
Put the machine in place.....	4:1
Remove the rust preventer.....	4:1
Check the knife clearance.....	4:1
Technical specifications.....	4:1
Install the hopper.....	4:2
<b>Electrical connection</b> .....	<b>4:4</b>
General rules, Electrical connection.....	4:4
Emergency stop.....	4:4
Level switch (optional).....	4:4
Current relay (optional).....	4:4
Connect the granulator to the mains.....	4:4
<b>Start the granulator</b> .....	<b>4:5</b>
<b>Check immediately after first start</b> .....	<b>4:5</b>
<b>Check five hours after first start</b> .....	<b>4:5</b>

## 5. START / STOP

<b>Start the granulator</b> .....	<b>5:1</b>
<b>Stop the granulator</b> .....	<b>5:1</b>

## 6. OPEN / CLOSE

<b>Open the granulator</b> .....	<b>6:1</b>
General rules, Open the granulator.....	6:1
Open the enclosure (-K).....	6:1
Open the transmission.....	6:1
Open the cutter housing.....	6:2
Open the granule bin.....	6:3
Open the screen box.....	6:3
Open the hopper.....	6:3
<b>General rules, Close the granulator</b> .....	<b>6:4</b>
Close the hopper.....	6:4
Close the screen box.....	6:4
Close the granule bin.....	6:4
Close the cutter housing.....	6:5
Close the enclosure (-K).....	6:1
Close the transmission.....	6:1

## 7. SERVICE

<b>General rules, Service</b> .....	<b>7:1</b>
Emergency stop(s).....	7:1
Flap(s).....	7:1
Lubrication.....	7:1
Service schedule.....	7:1
Safety equipment.....	7:2
Electrical components.....	7:2
Level switch.....	7:3
Current relay.....	7:4
Band conveyor.....	7:5
Cleaning.....	7:6
<b>Knives</b> .....	<b>7:7</b>
General rules, Knives.....	7:7
Remove the rotating knives.....	7:7
Remove the fixed knives.....	7:7
Install the fixed knives.....	7:8
Install the rotating knives.....	7:9
Preset the rotating knives.....	7:10
Preset the fixed knives.....	7:10
General rules, Grind the knives.....	7:11
Grind the fixed knives.....	7:11
Grind the rotating knives.....	7:12
<b>Drive belt(s)</b> .....	<b>7:13</b>
General rules, Drive belt(s).....	7:13
Check the drive belts(s).....	7:13
Adjust the belt tension.....	7:13
Belt tension table.....	7:14
<b>Troubleshooting</b> .....	<b>7:15</b>

## 8. SERVICE REPORT

<b>Service actions</b> .....	<b>8:1</b>
------------------------------	------------

**9. SPARE PARTS**

**General rules, Spare parts..... 9:1**

- Feed tray, Funnel ..... 9:2
- Inlet ..... 9:3
- Flap(s) ..... 9:4
- Hopper ..... 9:5
- Hopper device ..... 9:6
- Safety Hopper & Cutter housing ..... 9:7
- Cutter housing ..... 9:9
- Rotor ..... 9:11
- Knives ..... 9:12
- Screen box, Screen ..... 9:14
- Granule bin, Discharge ..... 9:15
- Transmission, Motor, Flywheel ..... 9:16
- Safety Transmission ..... 9:18
- Safety Enclosure ..... 9:19
- Safety Electrical cabinet ..... 9:21
- Body ..... 9:22
- Options, Level switch, Hours counter,  
Stand still/Speed monitor, Current relay ..... 9:23
- Material transport, Blower,  
Band conveyor, Dust separator system ..... 9:24
- Blower ..... 9:25

**APPENDIX A**

- Wer're Here to Help ..... A-1**
- Equipment Guarantee ..... A-2**

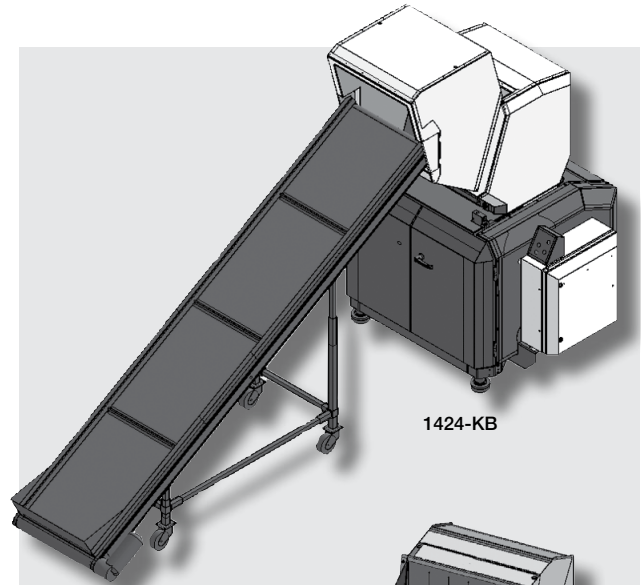

1424-KB

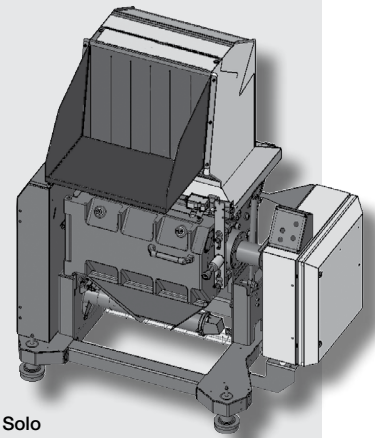

1424 Solo

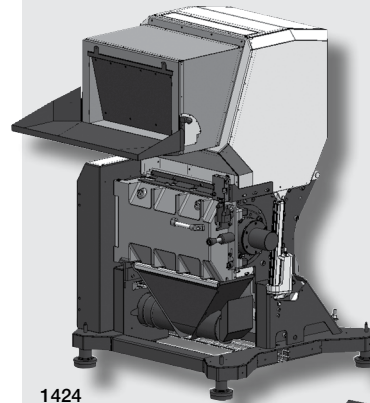

1424

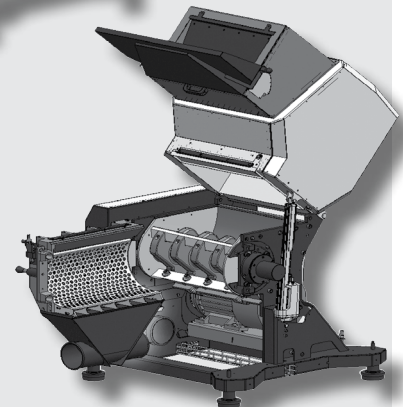

1424

## General rules, Safety

Conair designs granulators, shredders, guillotines and surrounding equipment for processing injection moulded, blow moulded or extruded plastics waste. Size and performance is designed and adapted to the type of plastic residue that the customer has specified before order.

The machines are manufactured in accordance to the state of the art and legal safety regulations (guidelines, harmonised standards), which demand very low safety risk. But, if the machines are incorrectly operated, unexpected dangers can arise. Therefore it is very important that the safety rules on the following pages are carefully observed. If there are any questions, please contact Conair's local distributor or Conair's main office.



**Danger! It is not permissible to feed the machine with flammable material or material contaminated with flammable or easily ignited substances.**



**Danger! It is not permissible to feed the machine with wood products, household or garden waste, pharmaceutical products or substances which present a health danger, unless written permission has first been obtained from Conair's main office. If any materials are processed that are not contractually agreed upon, Conair is absolved of any liability and guarantee for safety and functioning of the machine.**



**Danger! No modifications or alterations to Conair's products are permissible unless written approval has first been obtained from Conair's Main Office. This is to prevent injury, so that the machinery warranty will be valid, and so that Conair can fully assume their product liability.**

## Warning signs on the machine



**Danger! Risk of cutting or pinch injuries! This sign is placed anywhere there is a risk of cutting or pinch injuries.**



**Danger! Dangerous voltage! This sign is placed on electrical cabinet hatches and on any junction boxes.**



**Danger! Read the instruction manual before installing and operating the machine.**

## Warnings in the instruction manual



**Danger! This symbol is used to indicate risk of personal injury. The symbol inside the triangle may have different appearances, depending on the type of danger.**



**Important! This symbol is used to indicate risk of machinery damage.**



**Information! This symbol is used to highlight useful information.**

## Safety rules, During Installing



- The machine must be installed by authorized, trained personnel.
- All instructions must be observed to avoid machinery damage and personal injury.
- The machine must be installed and connected to other equipment so that the entire installation complies with the stipulations of the Machinery Directive 98/37/EG.

## Safety rules, During start and operation



- The instructions in the instruction manual must be followed.
- National environmental and employee safety regulations must be followed.
- The machine must be correctly installed.
- The hatches for electrical cabinets, transmission and pneumatics (if installed) must be closed during start and operation. The key must be kept by the personnel responsible for the machine's service and safety.
- The screen must be installed.
- The screen box must be closed.
- The granule bin must be closed.
- The hopper must be closed.
- All safety switches must be installed.
- All outer safety equipment such as protective screens, bars, covers, plates, nets etc must be installed.
- Body with wheels (optional): The wheels must be locked.



- Be very careful. The machine contains rotating knives. Risk of cutting or pinch injuries!
- Never place any part of your body in any opening. Risk of cutting or pinch injuries!
- Use ear defenders. Risk of loud, damaging noise!
- Use protective goggles. Risk of granulate splashing!
- Do not tread on the machine.



- Granulator with additional suffixes -K (Enclosure):
  - The enclosure must be closed.



- Granulator with additional suffixes -U (Blower):
  - Be very careful. The blower has very powerful suction and blowing ability. Never place any parts of your body in or near the suction or blower outlet openings.
  - Blowers must not be used in ambient temperatures above +40°C, in ambient temperatures below -20°C, in explosion hazard atmospheres or unprotected outdoors.
  - The temperature of the transported material must never increase +80° C.



- Granulator with additional suffixes -B (Band conveyor):
  - Be very careful. Clothing and parts of your body can be dragged along with the conveyor band.
  - Do not tread on the band conveyor.
  - If hot material is to be transported on the band, this must be placed in the middle of the band. Uneven heating of the band can make the band pull to one side.

## Safety rules, During service



- The instructions in the instruction manual must be followed.
- National environmental and employee safety regulations must be followed.
- First aid and eye shower must be within reach.
- Daily service and daily checks may be done by the operator. All other service and inspections must be done by authorised, trained personnel.
- Always work alone at the machine when service actions is performed.
- Use protective goggles and gloves.
- The granulator's main switch must be locked in position "0". Never insert any part of your body into any opening, unless the main switch is locked in position "0".
- The granulator must be disconnected from the mains before electrical repairs is began.



- Be very careful – When opening and closing the machine. Risk of cutting or pinch injuries!
- Be very careful – When checking and changing drive belt. Risk of cutting or pinch injuries!
- Be very careful – When the machine is opened the knives are accessible. The knives are sharp, and they may cause personal injuries even when they are not rotating. Risk of cutting or pinch injuries!
- Be very careful – When the rotor is to be turned manually. The rotor can rotate by itself. Always lock the rotor with a piece of wood to avoid the rotor from self-rotating.
- Be very careful – When cleaning granulate and plastic residue can make the floor slippery.
- Be very careful – When working on high level. Only use specially installed and fastened steps, stairs and platforms. It is not permissible to remove any outer safety equipment such as protective screens, bars, nets etc.
- After service / check is done the hatch(es) for the electrical cabinet, transmission and pneumatics (if installed) must be closed and locked. The key must be kept by the personnel responsible for the machine's service and safety.



- Granulator with additional suffixes -B (Band conveyor):
  - The band conveyor's main switch must be locked in position "0".
  - The band conveyor's mains plug must be disconnected from the mains.

## Risk of machinery damage

- If incorrect material is fed into the machine.
- If the belt tension is incorrect or if the drive belts are worn.
- If the screen in the screen box is worn or incorrectly installed.
- If the knives' tightening screws are tightened with incorrect torque.
- If the knives are blunt.



**Technical specifications**

**General Data, Supplied machine:**

Machine type: .....

Serial No:..... Manufacturing year:.....

Motor: ..... V ..... Hz ..... kW Electrical circuit diagram: .....

**General Data, 14 Series:**

Machine type: .....  14 Series  Solo

Model: .....  1418  1424  1436  1448

Additional suffix: .....  -K  -U  -B  -P  - RF

Cutter housing (CH): .....  Restricted Tangential, 1st  Super Tangential, 5th

Cutter housing width (Inside): .....  17 x 18 in (Restricted Tangential, 1st)  14 x 18 in (Super Tangential, 5th)  
 .....  17 x 24 in (Restricted Tangential, 1st)  14 x 24 in (Super Tangential, 5th)  
 .....  17 x 36 in (Restricted Tangential, 1st)  14 x 36 in (Super Tangential, 5th)

Fixed knives (Reversible, Grind able): .....  2 pcs (2nd & 5th)  2 pcs (2nd & 1st)  3 pcs (2nd, 1st & 5th)

Rotor: .....  3-blade  5-blade

Rotating knives (Grind able): .....  3 pcs / 1x3 (3-bl)  5 pcs / 1x5 (5-bl)

Screen Ø: .  4 mm  5 mm  6 mm  8 mm  10mm  12 mm  17 mm  25 mm  Hardened

Rotor speed: .....  1500 rpm (50 Hz)  1800 rpm (60 Hz)

Motor power: .....  7.5 kW  11 kW  18.5 kW  30 kW  37 KW  Flywheel

Drive belt(s): .....  3 pcs (7.5 kW, 11 kW)  3 pcs  4 pcs (18.8 kW, 30 kW, 37 kW)

Weight: .....  1418 (2094 lb)  1424 (2425 lb)  1436 (3600 lb)

Sound level\*, Idle running:  Std. Unit No Soundproofing, 90-95 dbA  With Optional Soundproofing, 80-85 dbA  
 \*(Depending on capacity, temperature etc)

Optional equipment: .....  Level switch, Paddle switch  Hours counter  
 .....  Current relay LVA, Y/D-start: Rated current ..... (/1A) /  $\sqrt{3}$  = ..... A  
 ..... LVA, Direct-start: Rated current ..... (/1A) / 1 = ..... A  
 .....  Knife grinding fixture  Knife setting fixture, Long

Material transport:.....  Blower F7  Blower F15  Blower F25  Blower F25-K  
 .....  Band conveyor  Metal detector, Tunnel  Metal detector, Area  
 .....  Cyclone AX 7.5  Cyclone AX 12  Cyclone AX 16

**Personnel responsible for the machine's service and safety:**

Name:..... Phone: .....

Name:..... Phone: .....

**Overview**

The performance of your supplied machine may vary from the standard machines described in this instruction manual. If there are any questions, please contact Conair's local distributor or Conair's main office.

- Hopper ..... (1)
- Inlet ..... (2)
- Flap(s) ..... (3)
- Feed tray ..... (4)
- Cover, Transmission ..... (5)
- Rotor pulley ..... (6)
- Drive belt(s) ..... (7)
- Motor pulley ..... (8)
- Motor ..... (9)
- Tightening screws, Motor ..... (10)
- Adjusting screws, Motor mounting bracket ..... (11)
- Safety Switch, Hopper / Cutter housing ..... (12)
- Jack, Hopper ..... (13)
- Cutter housing ..... (14)
- Door, Cutter housing ..... (15)
- Catch, Cutter housing ..... (16)
- Magnet switch, Granule bin ..... (17)
- Granule bin ..... (18)
- Screen box ..... (19)
- Screen ..... (20)
- Start-button ..... (21)
- Stop-button ..... (22)
- Emergency stop ..... (23)
- Button "Reset Safety Relay" ..... (24)
- Button "Operate 1" ..... (25)
- Button "Operate 2" ..... (26)
- Knob "Hopper, Close / Open" ..... (27)
- Hatch, Electrical cabinet ..... (28)
- Lock, Electrical cabinet ..... (29)
- Main switch ..... (30)
- Enclosure ..... (31)

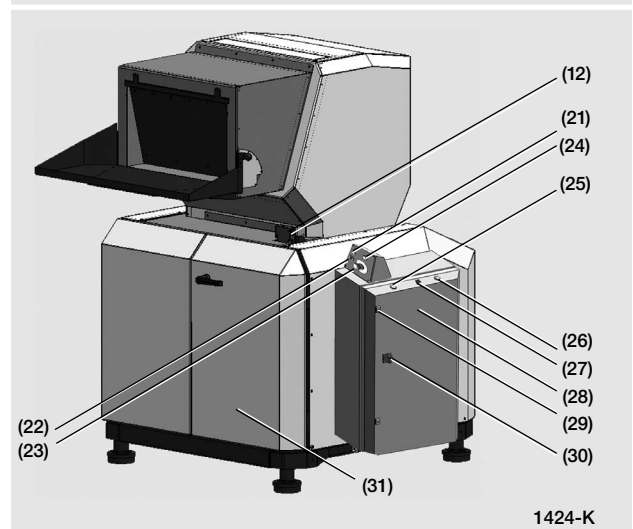
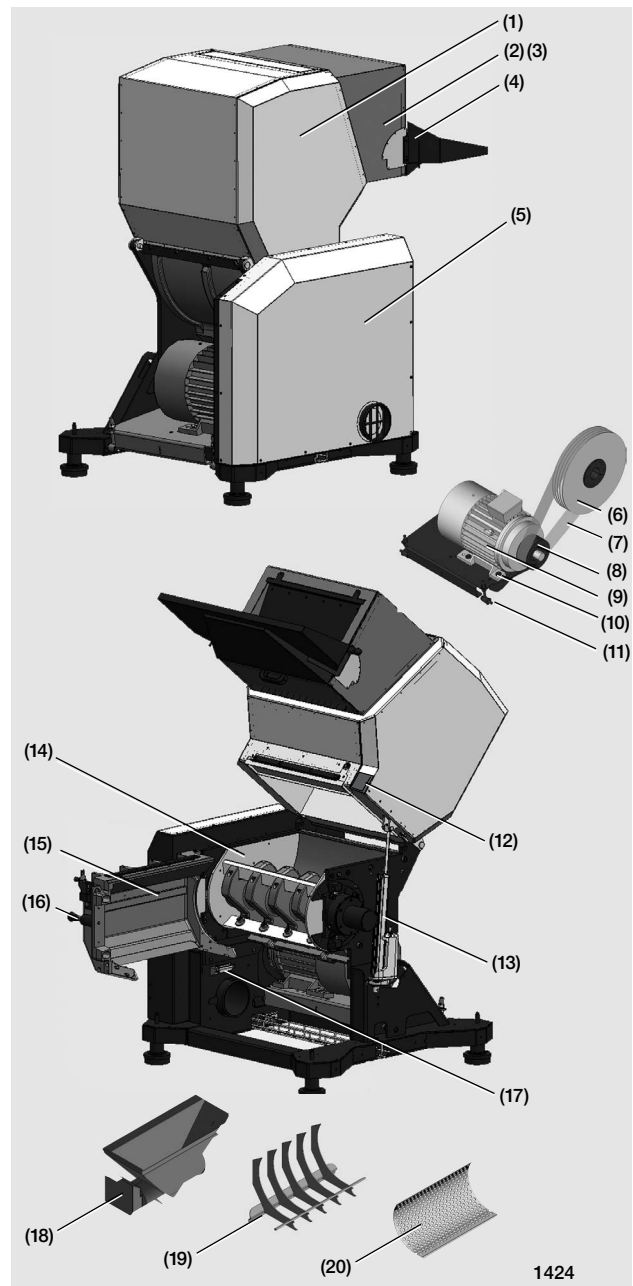

DESCRIPTION

Layout

1424  
HOPPER FRONT

LAYOUT NO: 4-53000-C01

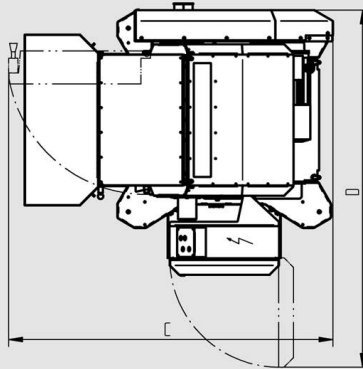
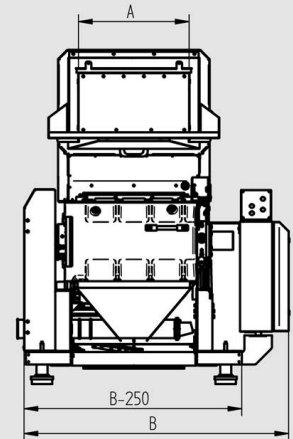
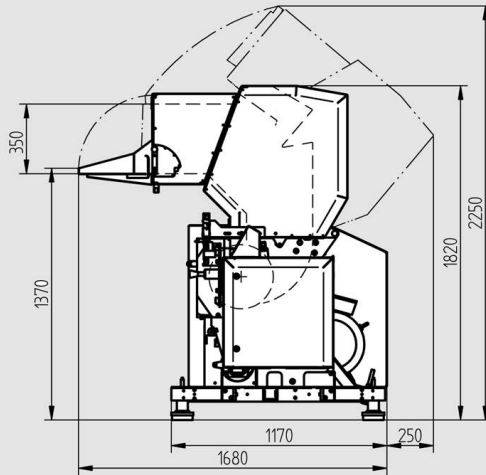
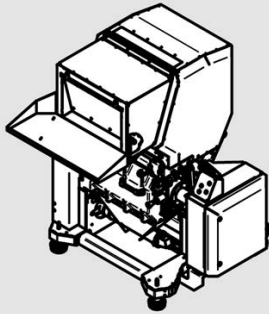

	1418	1424	1436	
A	450	600	900	
B	1290	1440	1740	
C	1620	1770	2070	
D	1800	1950	2250	

1424-K  
HOPPER FRONT

LAYOUT NO: 4-53000-C01

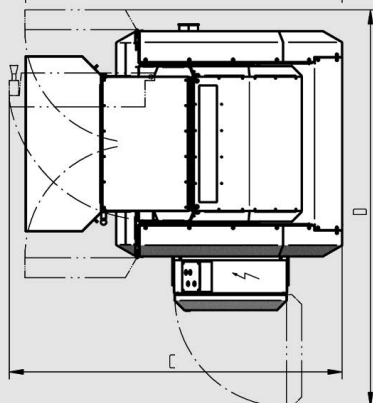
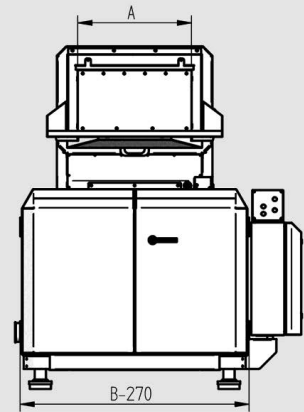
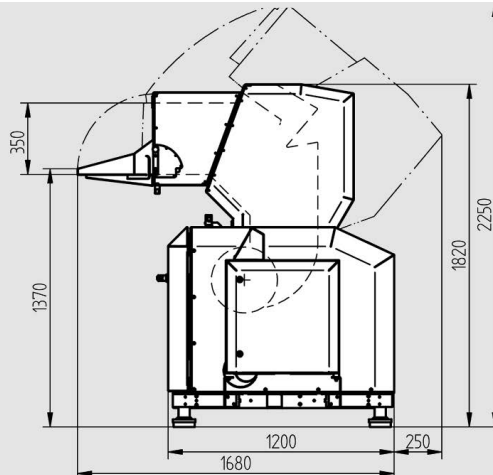
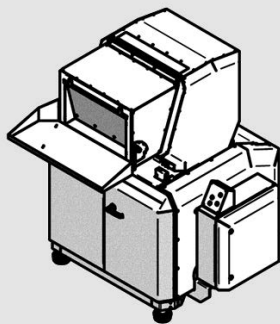

	1418	1424	1436	
A	450	600	900	
B	1340	1490	1790	
C	1620	1770	2070	
D	1950	2100	2400	

**Layout**

1424-KB  
BAND CONVEYOR FRONT

LAYOUT NO: 4-53015-C01

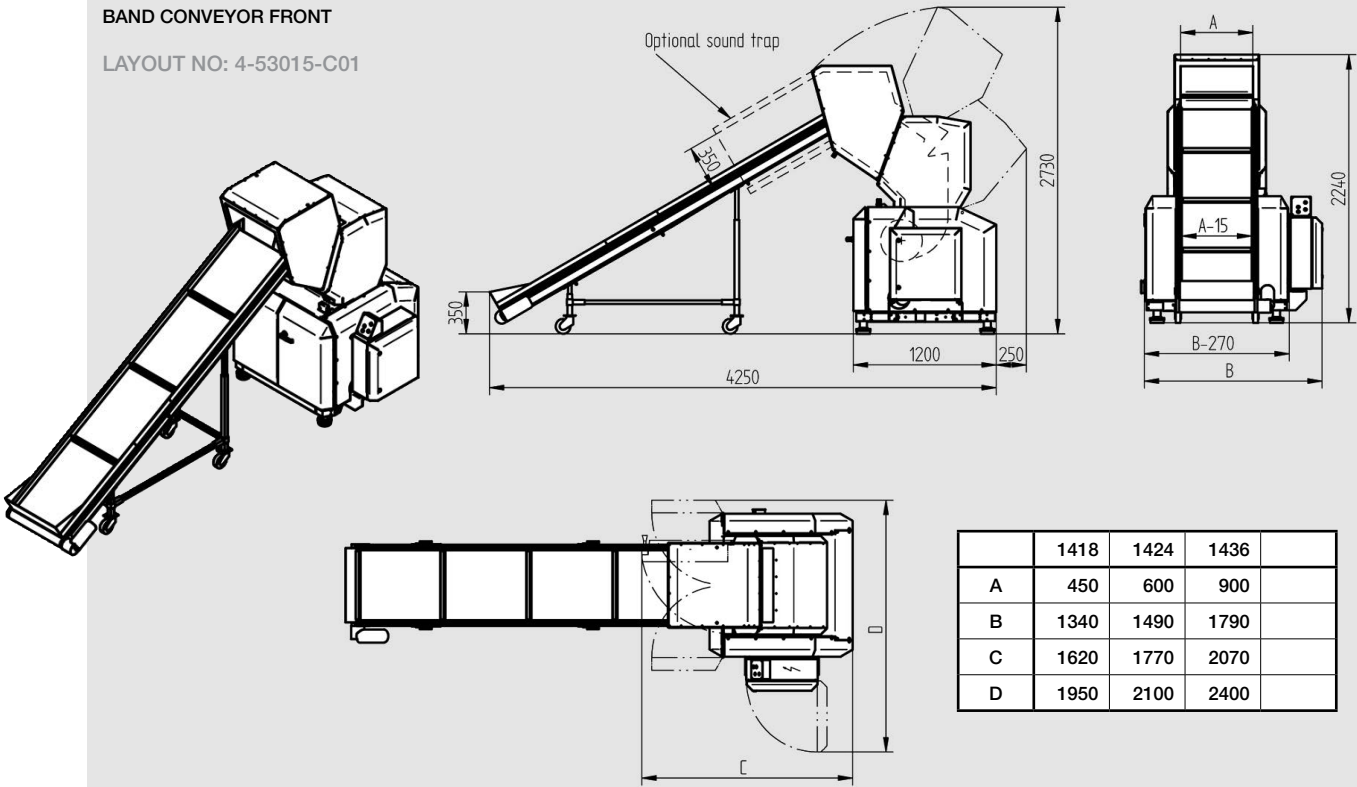

1424-KU  
HOPPER FRONT  
BLOWER F25 AX16-K

LAYOUT NO: 4-53014-C01

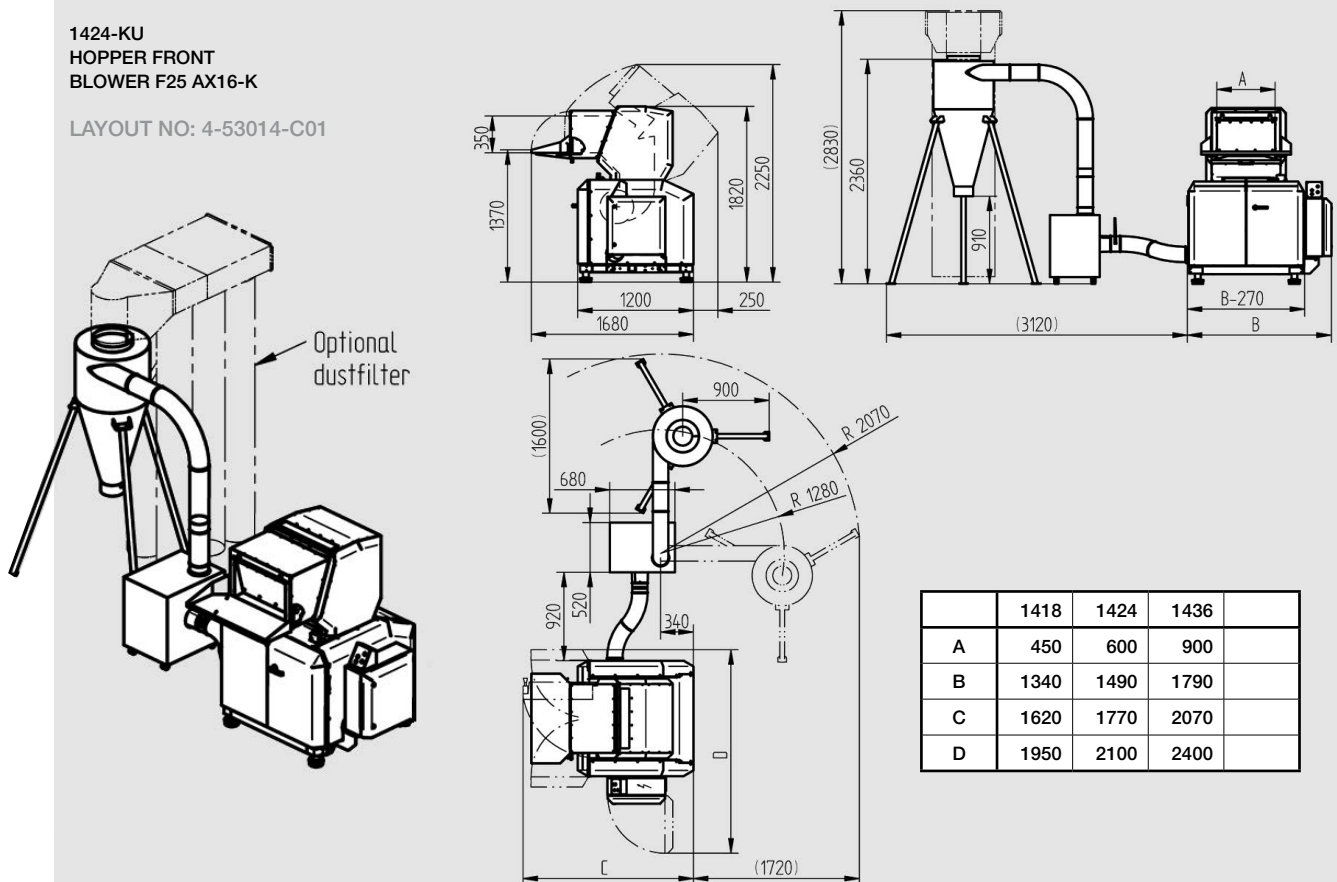

Layout

1424  
HOPPER FRONT  
SOLO

LAYOUT NO: 4-53024-B01

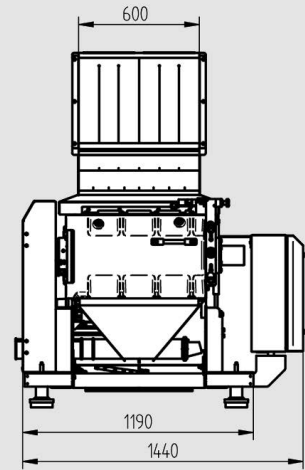
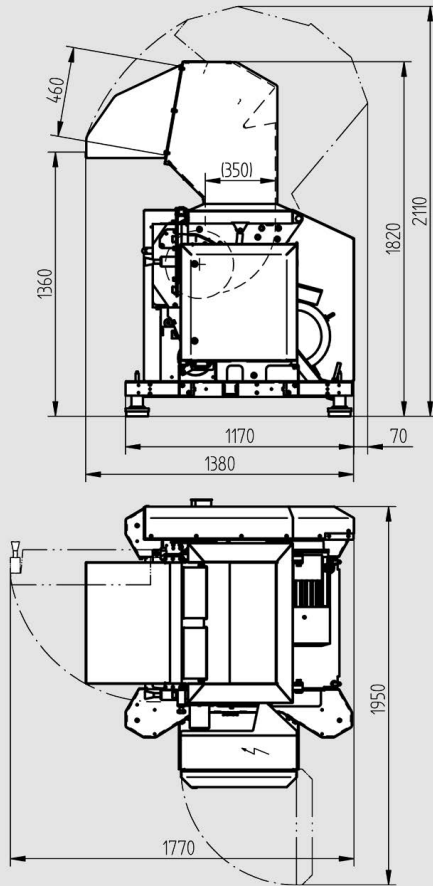
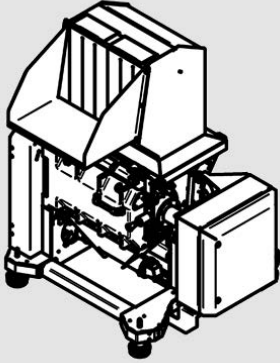

1424-B  
BAND CONVEYOR FRONT  
SOLO

LAYOUT NO: 4-53025-B01

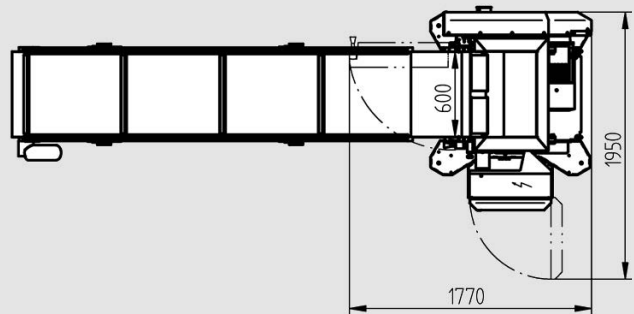
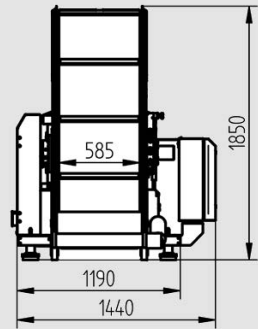
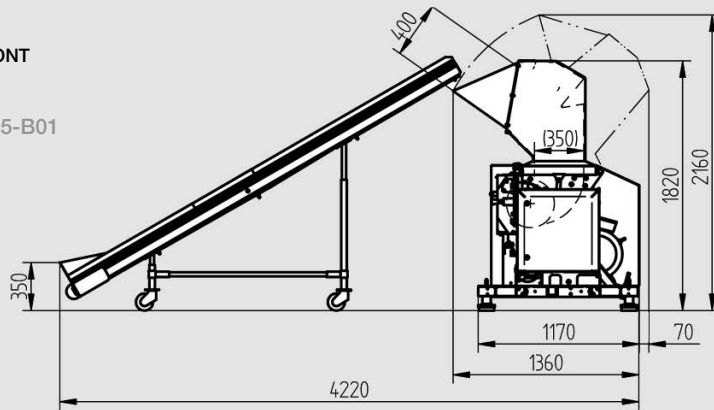
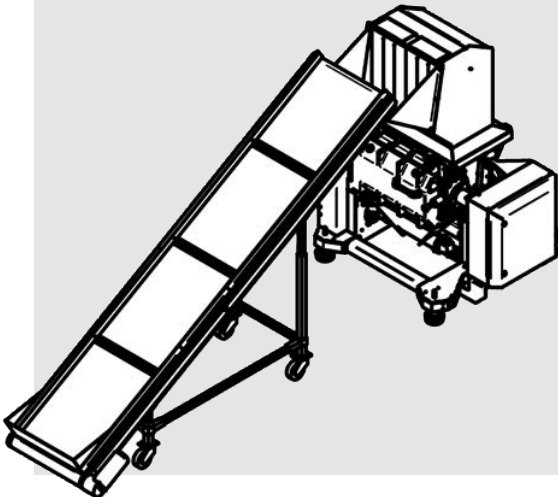

## Function

### Conair 14 Series

Conair 14 Series granulators are designed for granulating injection molded, blow molded or extruded plastic residue. The function of the granulator can be described as follows:

1. The plastic residue, which must be free from metal and contamination, is fed into the granulator's inlet. The inlet may be provided with a feed tray or a funnel.
2. The plastic residue falls through the hopper and down into the cutter housing. The cutter housing contains fixed knives and a rotor.
3. Rotating knives are mounted on the rotor. The plastic residue is granulated (cut up) between the rotating knives on the rotor and the fixed knives in the cutter housing. Both rotating and fixed knives must be replaced or grinded as necessary.
4. The size of the granulate (the cut up plastic residue) is determined by the screen. The screen is installed in the screen box in the base of the cutter housing. The screen can easily be changed to give the required granulate size.
5. The granulate passes through the screen down into the granule bin, which collects the finished granulate.
6. The granule bin can be emptied manually or by means of a blower.



Important! The machine must never be used with blunt knives. Blunt knives cause abnormal wear and damages the machine.

### Additional suffix 1418, 1424, 1436, and 1448

The additional suffix 1418, 1424, 1436 and 1448 refers to the cutter housing width.

### Solo

A Solo granulator is an economic, basic 14 Series granulator. The Solo granulator is not modifiable. The Solo granulator is only available in the model number 1424.

### Standard 14 Series

A Standard 14 Series granulator is a modifiable 14 Series granulator. Parts of the granulator can be custom built to meet the customer's needs.

### Optional wear package

The 14 Series granulator is a modifiable, extra tough 14 Series granulator. Parts of the granulator can be custom built to meet the customer's needs.

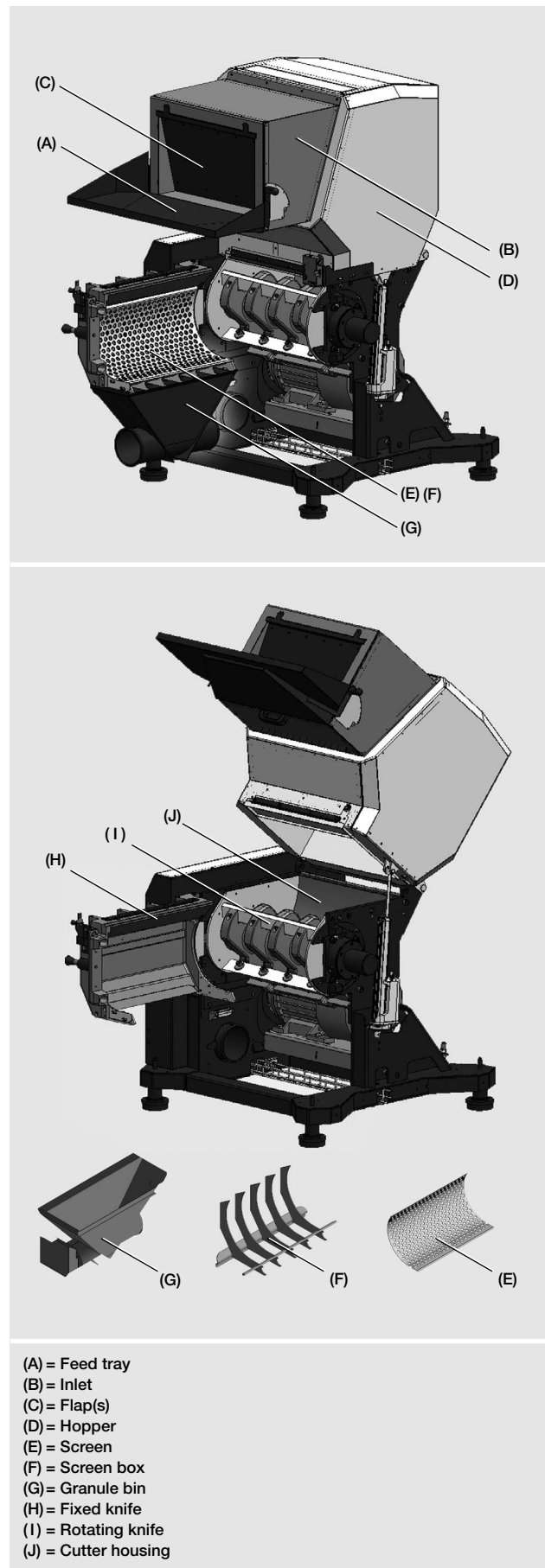

Continued

## Function (continued from previous)

### Additional suffix -K

Granulator with additional suffix -K is provided with a sound insulating enclosure. >Page 9:19 “Enclosure”

### Additional suffix -U

Granulator with additional suffix -U is provided with a blower. The blower transports granulate on from the granule bin to units such as a dust separation system or a granulator container for later use. Blowers are available with or without sound insulating enclosure. Optional blowers; F7, F15 or F25. >Page 9:25 “Blower”.

### Additional suffix -B

Granulator with additional suffix -B is provided with a band conveyor. The band conveyor transports plastic residue to the granulator’s inlet / hopper. The band conveyor can be provided with a metal detector. >Page 9:24 “Material transport”.

### Additional suffix -P

Granulator with additional suffix -P is provided with a hopper that is adapted to granulation of pipes and profiles. >Page 9:5 “Hopper”.

### Additional suffix -RF

Granulator with additional suffix -RF is provided with a roll feed. The roll feed contains rotating rollers which feed the plastic residue into the granulator’s cutter housing. Optional roll feed RFL, RFS, RFM. >Please refer to the separate instruction manual “14 Series RF”.

### Additional suffix -AX

Granulator with additional suffix -AX is provided with a cyclone. The cyclone separates air from the finished granulate. The cyclone’s air outlet can be provided with a filter. Optional cyclones; AX7.5, AX12, AX16.

### Additional suffix -DS, -TRACS, -TP

Granulator with additional suffix -DS is connected with a dust separator system. The dust separator system cleans the finished granulate. Optional dust separator systems; DS400, TRACS, TP2119 or TP2111. >Page 9:24 “Material transport”.

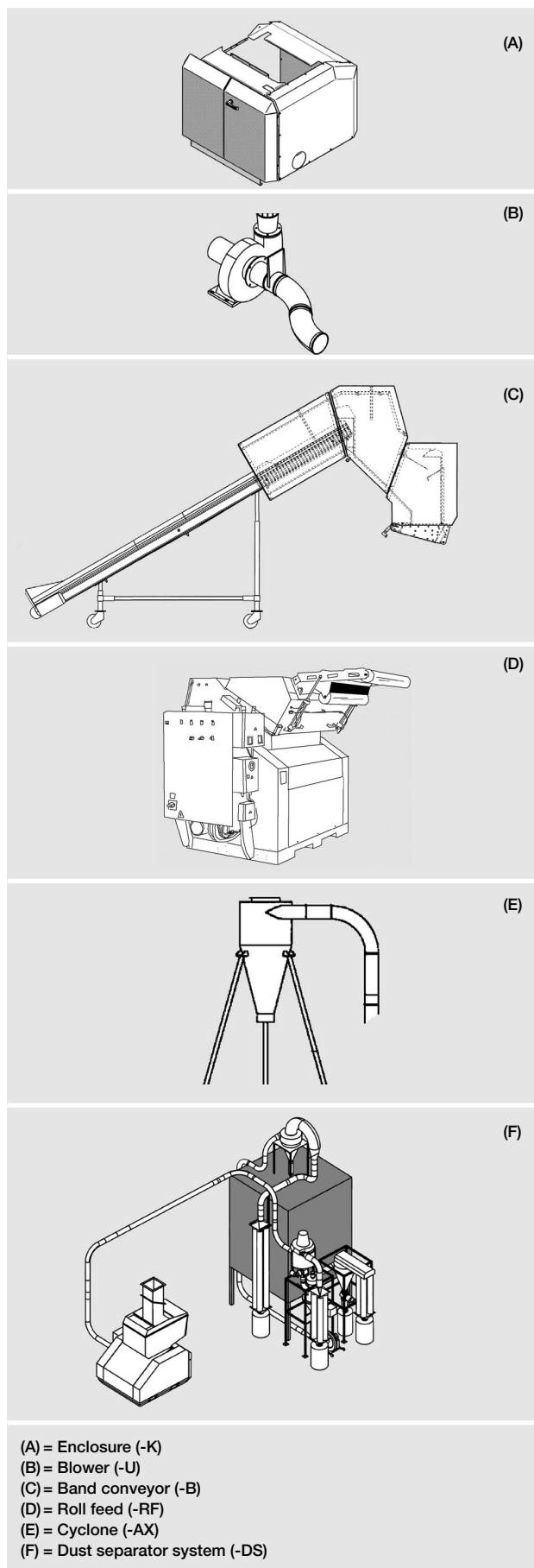

**Rotor**

**General rules, Rotor**

The rotor is designed and adapted to the type of plastic residue that the customer has specified before order. 14 Series can be provided with a 3-blade rotor or a 5-blade rotor. >Page 9:11 “Rotor”.

**3-blade rotor**

The 3-blade rotor has three knife rows with one rotating knife per row.

**5-blade, rotor**

The 5-blade rotor has five knife rows with one rotating knife per row.

**Rotating knives**

Rotating knives are mounted on the rotor. The rotating knives are fixed with washers and tightening screws. The rotating knife is provided with adjusting screws that facilitates the knife clearance setting.  
>Page 7:9 “Install rotating knives”.

The granulator must never be used with blunt knives. Blunt knives cause abnormal wear and damages the granulator. The rotating knives must be replaced or grinded as necessary.  
>Page 7:12 “Grind the rotating knives”.  
>Page 9:12 “Knives”.

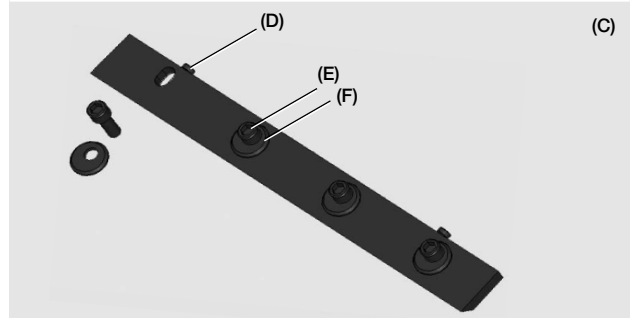
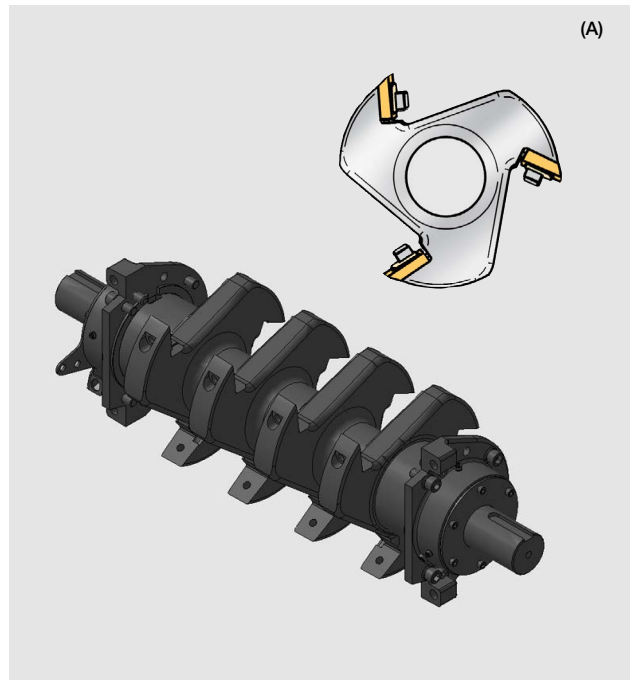

(A) = 3-blade rotor  
 (B) = 5-blade rotor  
 (C) = Rotating knife  
 (D) = Adjusting screw, Rotating knife  
 (E) = Tightening screw, Rotating knife  
 (F) = Washer, Rotating knife

## Cutter housing

### General rules, Cutter housing

The cutter housing is designed and adapted to the type of plastic residue that the customer has specified before order. The cutter housing can be provided with two or three fixed knives, depending on type of cutter housing. There are two types of cutter housings, cutter housing Restricted Tangential; “First” and cutter housing Super Tangential; “Fifth”.

>Page 9:9 “Cutter housing”

### Cutter housing Restricted Tangential; “First”

Cutter housing Restricted Tangential; “First” has a tangential back. Cutter housing Restricted Tangential; “First” has three knife seats.

Possible configurations:

- Front fixed knife (2nd), Rear fixed knife (5th), Rear fixed knife (1st).
- Front fixed knife (2nd), Rear fixed knife (5th). (The empty knife seat must be provided with a dummy).

### Cutter housing Super Tangential; Fifth

Cutter housing Super Tangential; Fifth has a super tangential back. Cutter housing Super Tangential; Fifth has two knife seats.

Possible configurations:

- Front fixed knife (2nd), Rear fixed knife (5th).

## Fixed knives

The front fixed knife is installed in the cutter housing’s front. The rear fixed knife/knives is/are installed in the cutter housing’s back. The fixed knives are fixed with support rules and tightening screws. The fixed knife is provided with adjusting screws that facilitates the knife clearance setting. >Page 2:10 “Knife clearance”

The granulator must never be used with blunt knives. Blunt knives cause abnormal wear and damages the granulator. The fixed knives must be replaced, grinded or reversed as necessary. Fixed knives are reversible, this means that the fixed knives have two cutting edges and can be reversed once before grinding or discarding is necessary.

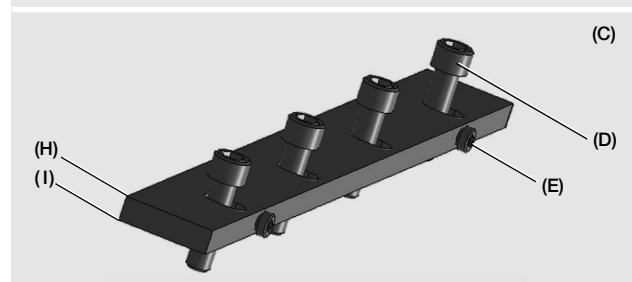
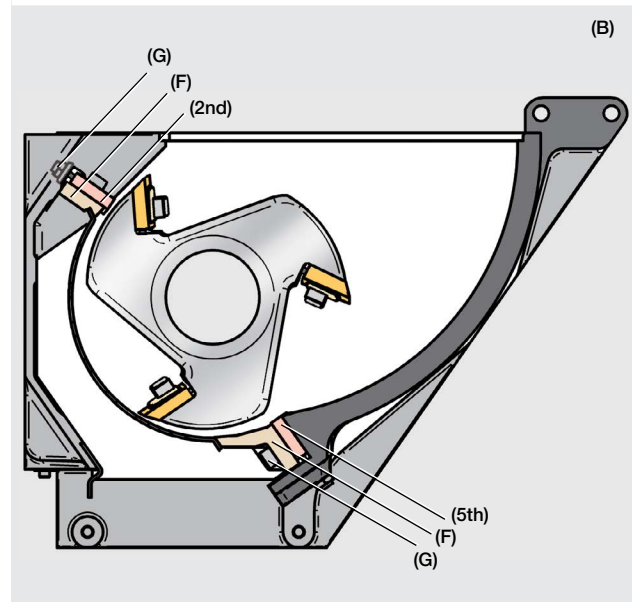
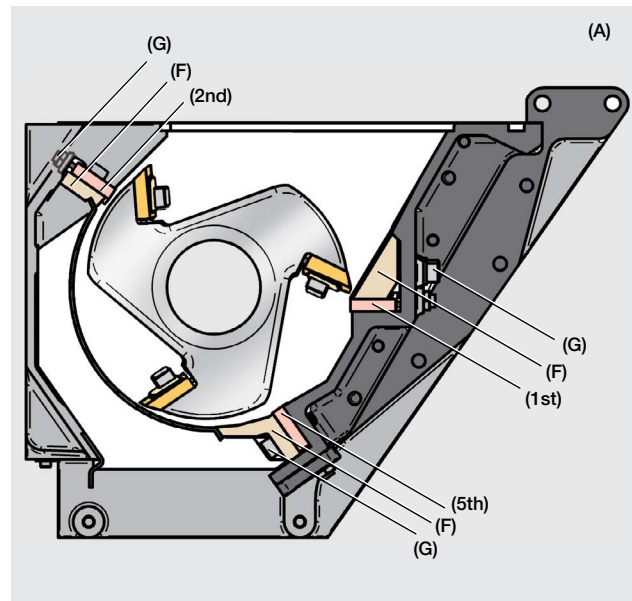

- (A) = Cutter housing 1st
- (B) = Cutter housing 5th
- (C) = Fixed knife
- (D) = Tightening screw, Fixed knife
- (E) = Adjusting screw, Fixed knife
- (F) = Support rule, Fixed knife
- (G) = Grub screw, Cutter housing
- (H) = Cutting edge No 1, Reversible fixed knife
- (I) = Cutting edge No 2, reversible fixed knife
- (1st) = Rear fixed knife, 1st “First”
- (2nd) = Front fixed knife, 2nd (Second)
- (5th) = Rear fixed knife, 5th “Fifth”

### Knife grinding fixture

The knife grinding fixture (optimal) is used when grinding the knives. The knife grinding fixture has two knife positions, one adapted for the fixed knife and one adapted for the rotating knife.

>Page 7:11 “General rules, Grind the knives”.

>Page 9:23 “Options / Knife grinding fixture”.

### Knife clearance

The knife clearance is the gap between the fixed knife and the rotating knife. Correct knife clearance is 0.008–0.016 in {0.20– 0.40 mm}. The knife clearance is checked with a feeler gauge. >Page 7:8 point 13 “Install the fixed knives”.

The knife clearance is adjusted by tightening / unscrewing the knife’s adjusting screws. The knife clearance is adjusted in a knife setting fixture.

>Page 2:10 “Knife setting fixture”.

### Knife setting fixture

The knife setting fixture is used when presetting the knives’ adjusting screws.

>Page 7:10 “General rules, Preset rotating the rotating knife” and “Preset the fixed knife”.

>Page 9:23 “Options / Knife setting fixture”.

Two short knife setting fixtures are enclosed on delivery. One is meant for presetting rotating knives and the other is meant for presetting fixed knives.

There is also a long knife setting fixture available (optional). The long knife setting fixture is convenient as it makes it possible to preset the knife in one step.

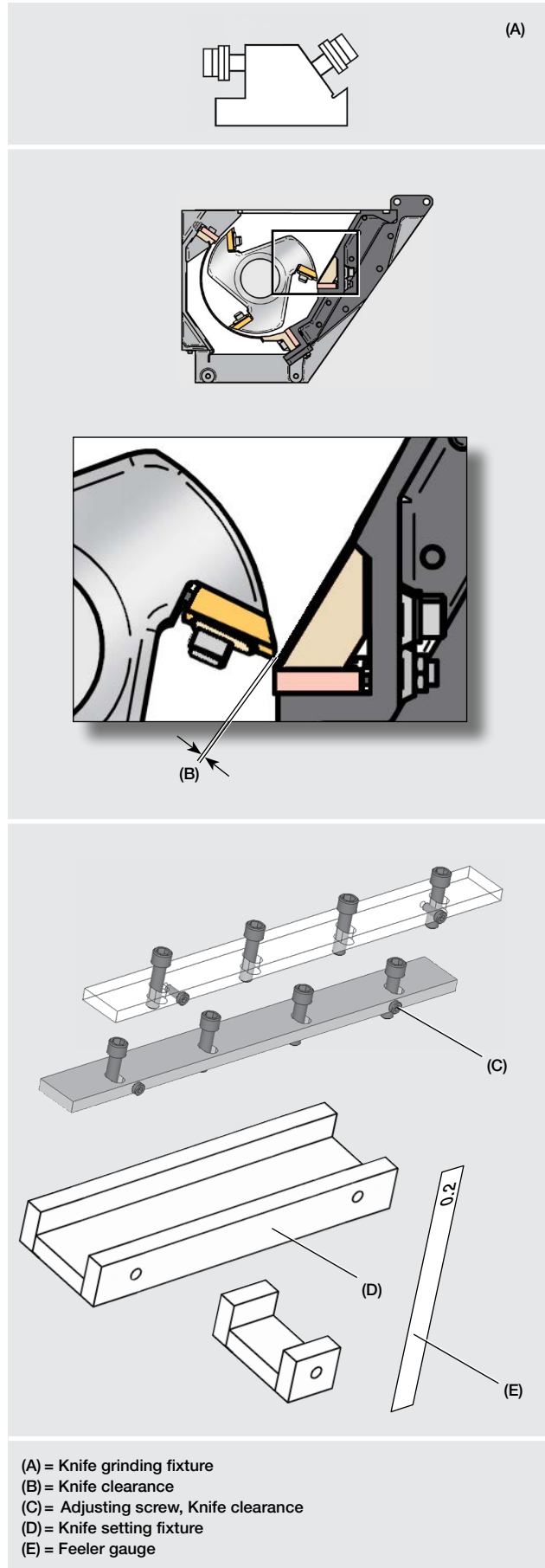

(A) = Knife grinding fixture  
 (B) = Knife clearance  
 (C) = Adjusting screw, Knife clearance  
 (D) = Knife setting fixture  
 (E) = Feeler gauge

**Transmission**

**Motor**

The granulator is driven by an electric motor. The motor is installed on a motor mounting bracket.

Optional motor speed: 1500 rpm (50 Hz) or 1800 rpm (60 Hz).

Optional motor power: 10 Hp {7.5 kW}, 15 Hp {11.0 kW}, 25 Hp {18.7 kW}, 40 Hp {29.8 kW}, or 50 Hp {37.3 kW}.

>Page 9:16 “Transmission”.

Motor power and motor frequency are specified on the motor’s machine plate.

**Drive belt, Motor pulley, Rotor pulley**

The granulator is provided with 3 or 4 drive belts depending on the motor power. The drive belts are tensioned between the motor pulley and the rotor pulley.

The drive belts must be checked regularly. The granulator must not be driven with worn drive belt(s) nor with incorrect belt tension. The belt tension is adjusted by moving the motor mounting bracket upwards or downwards. >Page 7:13 “General rules, Drive belt(s)”.

**Flywheel**

The granulator may be provided with a flywheel (optional). The flywheel is installed on the opposite side of the rotor pulley. The flywheel optimizes the kinetic energy and makes the granulator even more powerful.

>Page 9:16 “Flywheel”.

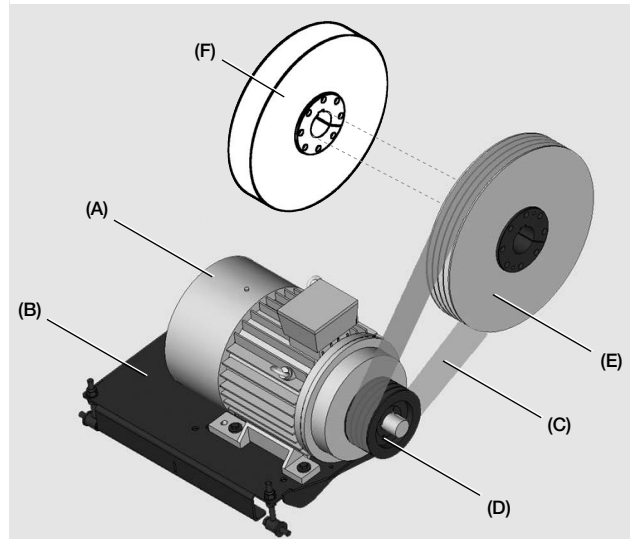
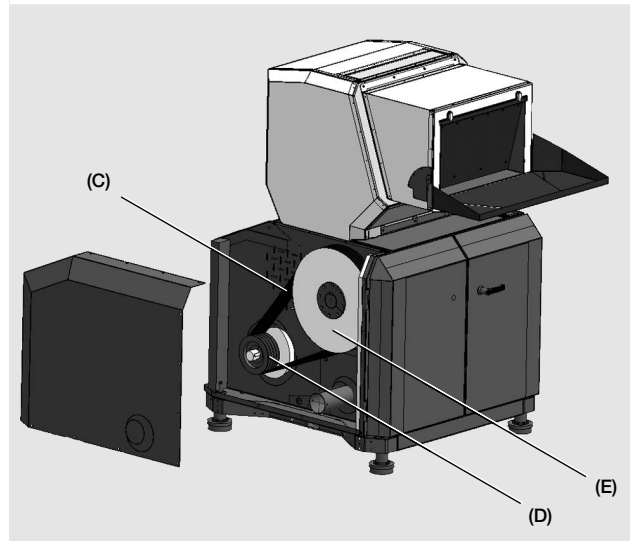
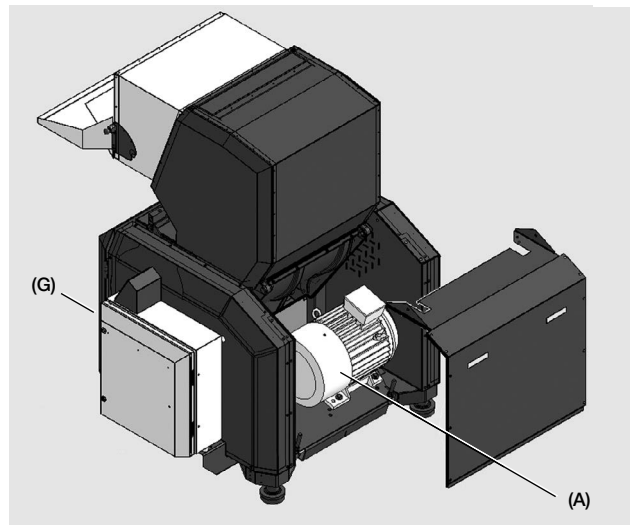

- (A) = Motor
- (B) = Motor mounting bracket
- (C) = Drive belt(s)
- (D) = Motor pulley
- (E) = Rotor pulley
- (F) = Flywheel
- (G) = Machine plate

## Safety equipment

### General rules, Safety equipment

Inside the machine, knives rotate at high speed. For this reason, there is safety equipment which is intended to prevent access to hazardous components during operation.

The safety equipment must not be changed or modified under any circumstances. If any part of the safety equipment is changed or left out, the machine can be dangerous to use. If any part of the safety equipment is changed or left out, Conair's responsibility under the Machinery Directive ceases to apply.

The safety equipment must be checked regularly. No part of the safety equipment may be replaced by components other than spare parts supplied by Conair.

The safety equipment consists of:

- Inlet
- Hopper
- Flap(s)
- Screen
- Screen box
- Granule bin
- Main switch
- Emergency stop
- Stand still monitor
- Safety switch
- Star knob (Solo)
- Magnet switch
- Safety relay



Note! All these parts must be installed during start and operation.

- In addition, the key for the electrical cabinet, transmission and pneumatic cabinets (if installed), is part of the safety equipment.

Continued

**Safety equipment (continued from previous)**

**Inlet, Hopper**

The inlet and the hopper prevent access to hazardous components during operation. The inlet must be installed during start and operation. The hopper must be closed during start and operation.

The hopper is designed and adapted to the type of plastic residue that the customer has specified before order.  
>Page 9:5 “Hopper”.

The inlet is designed and adapted to the type of plastic residue that the customer has specified before order.  
>Page 9:3 “Inlet”.

The inlet may be provided with a feed tray or a funnel.  
>Page 9:2 “Feed tray, Funnel”.

**Flap(s)**

The flap(s) prevents fed material from rejecting. The flap(s) also prevents half-finished granulate from stenching out of the inlet. The flap(s) must be installed during start and operation. The flap(s) must be regularly checked and replaced as necessary.  
>Page 9:4 “Flap(s)”.

**Screen, Screen box**

The screen prevents access to hazardous components during operation. The screen must be installed during start and operation. The screen box must be closed during start and operation.

The screen is installed in the screen box in the base of the cutter housing. The screen can easily be changed to give the required granulate size.

The screen and the screen box are designed and adapted to the type of plastic residue that the customer has specified before order.  
>Page 9:14 “Screen, Screen box”.

**Granule bin**

The granule bin collects the finished granulate. The granule bin must be closed during start and operation.

The granule bin is designed and adapted to the type of plastic residue that the customer has specified before order.  
>Page 9:15 “Granule bin”.

The granule bin may be provided with a level switch (optional).  
>Page 2:16 “Level switch”.

The granule bin may be provided with a blower (optional).  
>Page 2:7 “Additional suffix -B”.

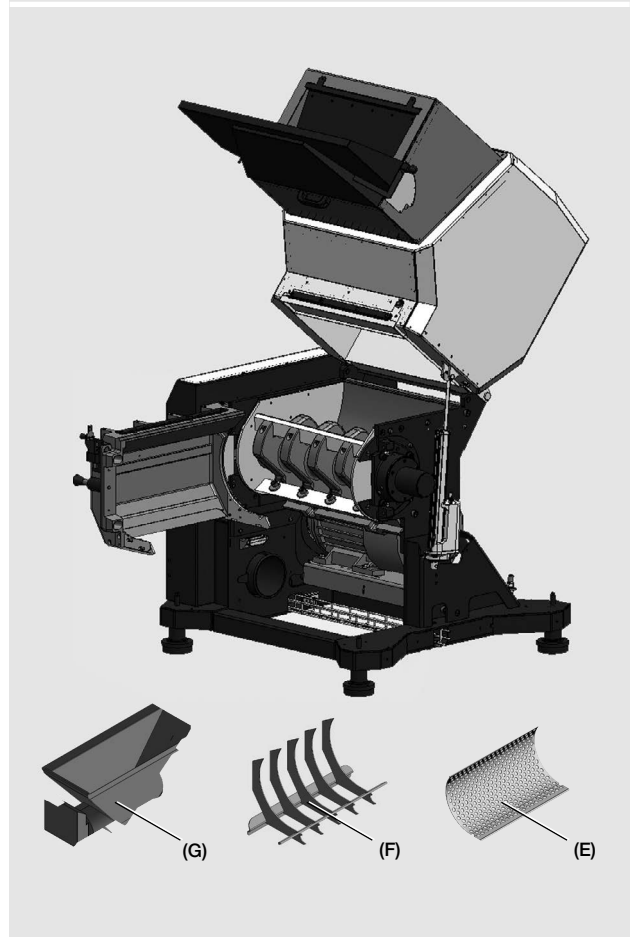
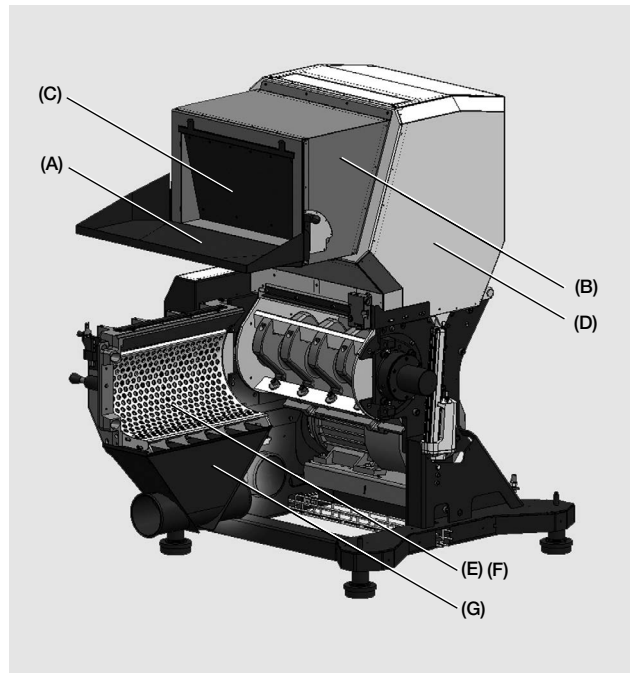

- (A) = Feed tray
- (B) = Inlet
- (C) = Flap(s)
- (D) = Hopper
- (E) = Screen
- (F) = Screen box
- (G) = Granule bin

Continued

**Safety equipment (continued from previous)**

**Main switch**

The main switch cuts all 3 phases of the supply voltage. The design and location of the main switch can vary. The granulator’s main switch must be locked in position “0” during service.

**Emergency stop(s)**

The emergency stop stops the machine in case of emergency. The machine may be provided with several emergency stops. The emergency stop(s) must be checked regularly.

The design and location of the emergency stop(s) can vary. The electrical circuit diagram shows the number of emergency stop(s) installed in the supplied machine.

**Key to electrical cabinets, transmission and pneumatic**

Hatches to electrical cabinet, transmission and pneumatics (if installed) must be closed and locked during start and operation. The key must be kept by the personnel responsible for the machine’s service and safety.

**Stand still monitor**

The stand still monitor monitors if the rotor is rotating or if it stands still.

The stand still monitor affects the lamp in the button “Operate 1” (optional). The button “Operate 1” is lit as the rotor stands still. The button “Operate 1” is used when opening a heavy hopper” >Page 6:3 “Open the hopper”.

The stand still monitor affects the switch key in the safety switch. >Page 2:15 “Safety switch”.

As long as the rotor is rotating the switch key will be locked inside the safety switch. (This means that it is not possible to open the machine immediately after stopping the machine, as the rotor will keep rotating for some minutes before it slows down and stands completely still.) As the rotor stands still the switch key is released and the green LED on the safety switch is lit.

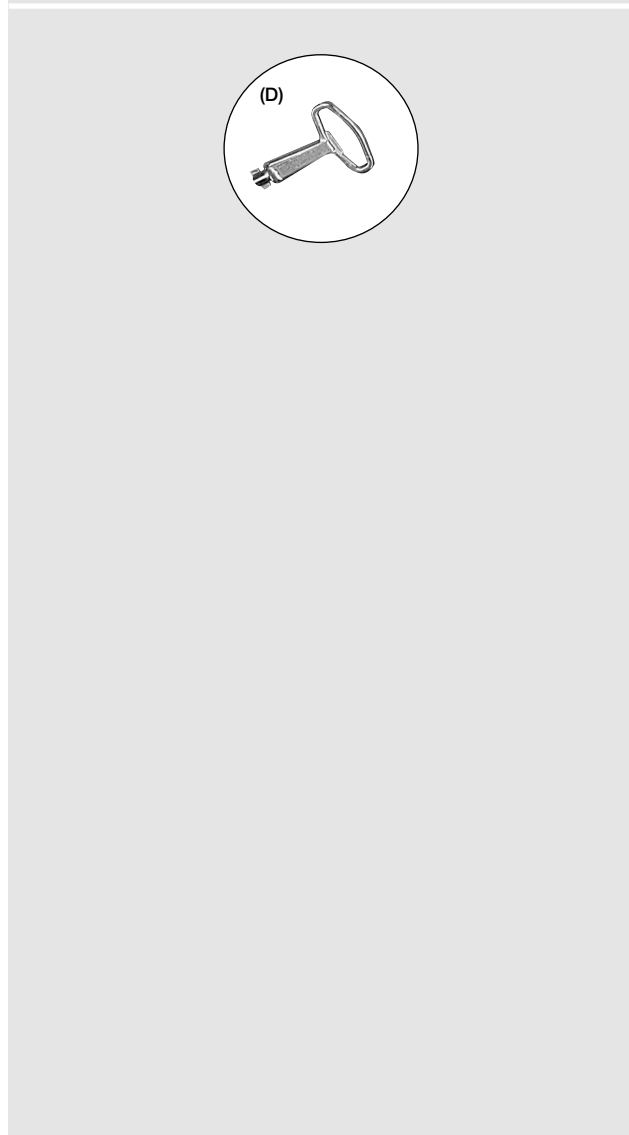
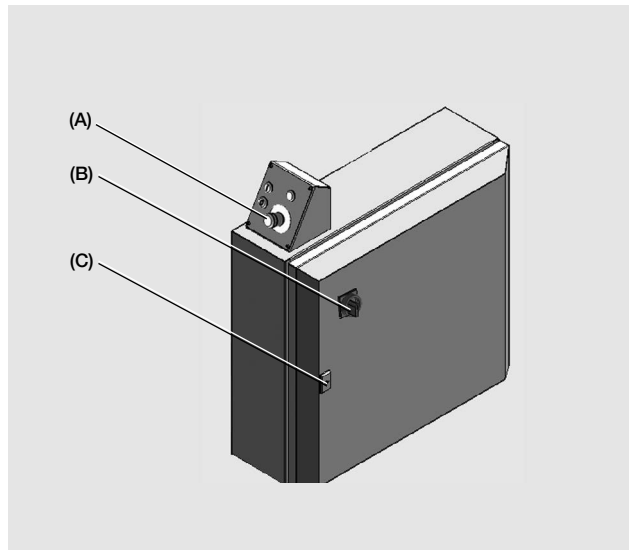

- (A) = Emergency stop
- (B) = Main switch
- (C) = Lock, Electrical cabinet
- (D) = Key to electrical cabinet, transmission and pneumatics

Continued

Safety equipment (continued from previous)

**Safety switch**

The machine may be provided with several safety switches which stops the machine if an unsafe mode is detected. The safety switch(es) must be checked regularly.

To be able to start the machine, the switch key must be installed inside the safety switch.

Standard 14 Series models: To be able to release the switch key from the safety switch, the green LED on the safety switch must be lit. >Page 2:14 “Stand still monitor”.

The design and location of safety switches can vary. Examples of where safety switches might be located can be seen in the figure on the right. The electrical circuit diagram shows the number of safety switches installed in the supplied machine.

**Star knob**

The machine may be provided with several star knobs which locks the machine. The star knob has a screw with a very long thread. The thread is so long because it has to take such a long time to unscrew the star knob that the rotor will have time to stop completely.

The star knob(s) must be checked regularly. Star knob with worn screw must only be replaced with a Conair original screw.

Some star knobs may be provided with a safety switch. If such a star knob is unscrewed during operation its safety switch will stop the machine. To be able to start the machine, the star knob(s) must be screwed in until they stop moving.

The design and location of star knobs can vary. Examples of where star knobs might be located can be seen in the figure on the right.

**Magnet switch**

The machine may be provided with several magnet switches that stops the machine if an unsafe mode is detected. To be able to start the machine, the two magnet halves must mate up close to each other.

Examples of where magnet switches might be located can be seen in the figure on the right. The electrical circuit diagram shows the number of magnet switches installed in the supplied machine.

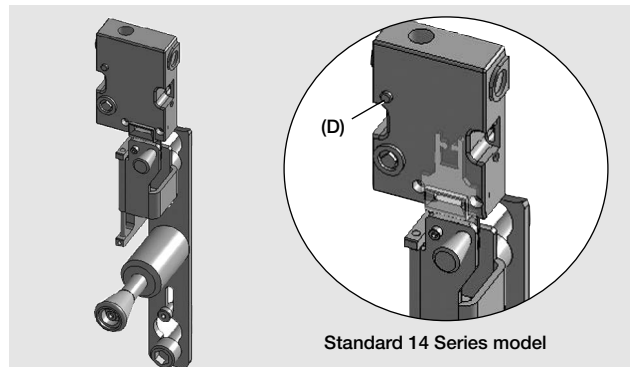

Standard 14 Series model

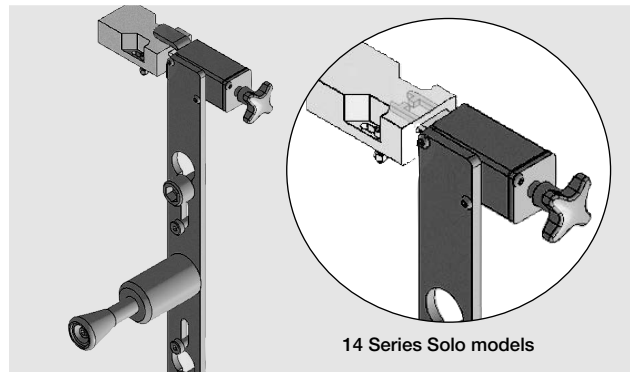

14 Series Solo models

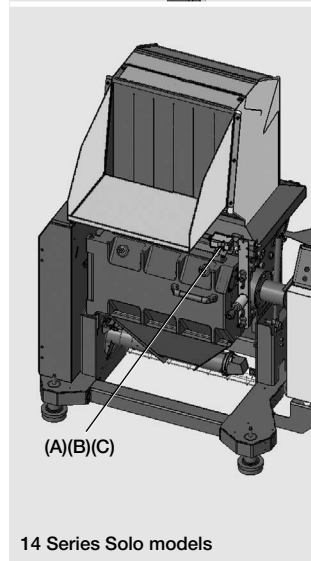

14 Series Solo models

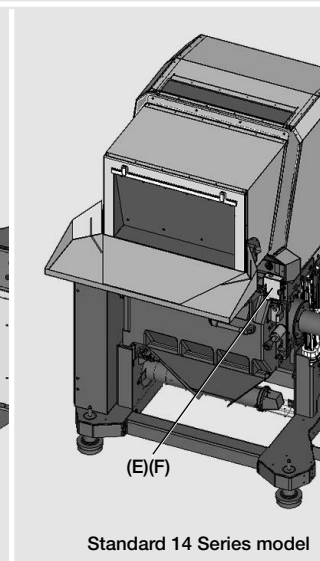

Standard 14 Series model

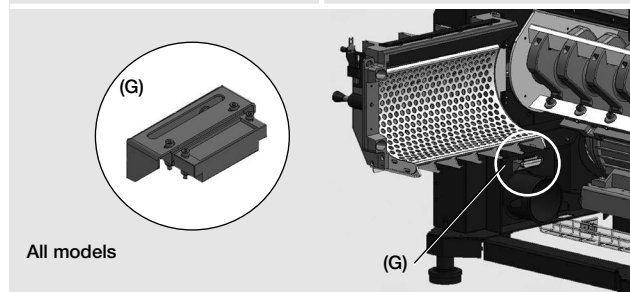

All models

- (A) = Star knob, Solo
- (B) = Safety switch, Solo
- (C) = Switch key, Solo
- (D) = Diode light, Safety switch
- (E) = Safety Switch, Standard 14 Series
- (F) = Switch key, Standard 14 Series
- (G) = Magnet switch

Continued

**Safety equipment (continued from previous)**

**Safety relay**

Standard 14 Series models are provided with a button “Reset safety relay”. The button “Reset safety relay” is installed on the operating panel. To be able to start the machine the button “Reset safety relay” must be pressed and lit. >Page 5:1 “Start the granulator” point 5.

If the button “Reset safety relay” does not light up, the safety relay has to be checked. >Page 7:3.

**Overload protection**

**General rules, Overload protection**

The machine may be provided with several overload protections. The electrical circuit diagram shows the number of overload protections installed in the supplied machine. The overload protection(s) is/are installed inside the electrical cabinet.

The overload protection trips if the granulator or any optional equipment is overloaded. Before resetting an overload protection and before restarting the machine, the reason why the overload protection tripped must be determined. Take necessary actions (for example clean the machine) to prevent the overload protection from immediate trip when restarting the machine.

**Overload protection**

If the reset knob is in position ”0” the overload protection has tripped. The overload protection is reset by turning the reset knob to position ”1”.

**Operating panel**

The machine may be provided with several operating panels. The design and location of the operating panel can vary. The operating panel(s) can be integrated with the electrical cabinet’s hatch and / or detached.



## Level switch

### General rules, Level switch

The granule bin may be provided with a level switch (optional). The level switch monitors the granule bin's granulate level.

As the granulate level gets too high, the level switch takes one or several of the below listed actions:

- Stops the optional feed equipment (such as a band conveyor or a roll feed).
- Lights up an optional warning lamp.
- Starts up an optional siren.
- Resets the level switch and restarts the granulator and/or the feed equipment as the granulate level in the granule bin has sunk.

### Level switch, Paddle type

The paddle switch is provided with rotating paddles. When the granulator is started the paddles starts rotating. If the granulate level gets too high, the paddles will stop rotating. As the paddles stands still, the level switch is activated.

The paddle switch's sensitivity can be adjusted by changing the position of the torsion spring. On delivery the paddle switch's torsion spring is installed in the second hole from the left. >Page 7:4 point 4 "Level switch".

## Hours counter

The granulator may be provided with an hours counter (optional). The hours counter counts the time the rotor is rotating. The hours counter has no reset.

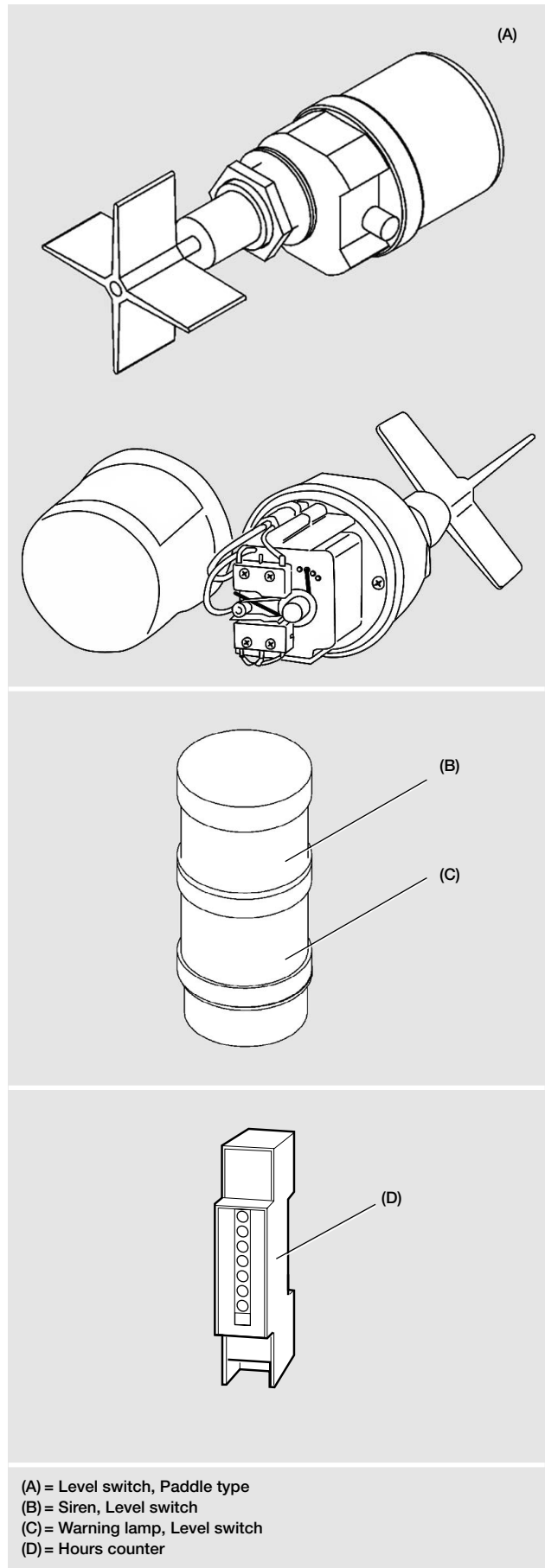

## Current relay

### General rules, Current relay

The granulator may be provided with a current relay (optional). The current relay monitors the granulator's current consumption.

As the granulator's current consumption exceeds the upper current level (LVA), the current relay trips and stops the feed equipment (such as a band conveyor or a roll feed).

The current relay is preset to automatically restart the feed equipment as the current consumption has sunk to the lower current limit (HA).

### Limit value ( LVA, LV%)

The limit value (LVA) is the preset current consumption level where the current relay trips and stops the feed equipment.

The limit value is adjustable. The limit value's adjusting knob is graded 0–100%.

The limit value in Ampere (LVA) is calculated as shown in the LVA-formulas on the right. Note! LVA is calculated differently as the granulator is "Y/D-started" or "Direct-started".

The limit value percentage (LV%) is calculated as shown in the LV% -formula on the right.

The electrical circuit diagram shows the rated current and the current transformer's size in the supplied machine.

### Hysteresis ( HA, H%)

The hysteresis is the preset current consumption level which determines when the current relay shall reset and restart the feed equipment.

The hysteresis is adjustable. The hysteresis' adjusting knob is graded 5–50%.

The hysteresis percentage (H%) applies to the limit value.

The hysteresis in Ampere is calculated as shown in the HA-formula on the right.

### Reaction time (T1)

The reaction time is the preset period of time that determines how long the current consumption shall exceed the upper current level (LVA) before the current relay shall trip and stop the feed equipment.

The reaction time is adjustable. The reaction time's adjusting knob is graded 0.1–3.0 sec.

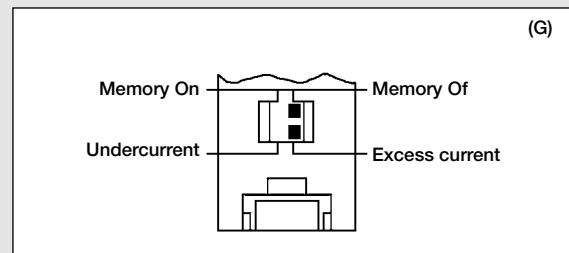
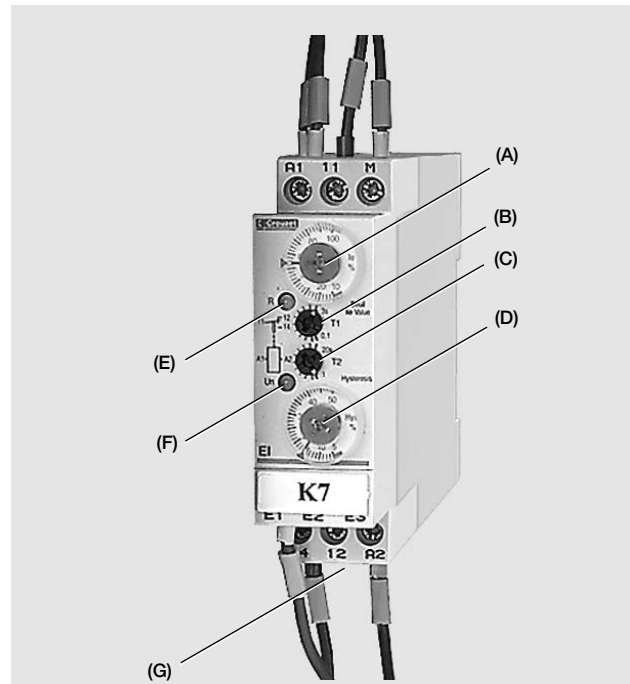

$$\begin{aligned} \text{LVA (Y/D-start)} &= \text{Rated current} / \sqrt{3} \\ \text{LVA (Direct-start)} &= \text{Rated current} \end{aligned}$$

$$\text{LV\%} = \frac{(\text{LVA} \times 100)}{\text{Current transformer size}}$$

$$\text{HA} = \frac{\text{LVA} - (\text{LVA} \times \text{H\%})}{100}$$

- (A) = Limit value percentage, LV%
- (B) = Reaction time, T1
- (C) = Time delay, T2
- (D) = Hysteresis percentage, H%
- (E) = Yellow LED, Current consumption
- (F) = Green LED, Control voltage
- (G) = Function settings

Continued

Current relay (continued from previous)

**Time delay during start up (T2)**

The time delay during start up is the preset period of time that determines how long the current consumption is allowed to exceed the upper current level during start. (When starting a machine the current consumption may temporarily exceed the upper current level (LVA).)

The function “Time delay during start up” is not used on Conair granulators. The time delay during start up’s adjusting knob should always be set to 0 seconds.

**Yellow LED**

The yellow led indicates the status of the current consumption.

- Steady light = The current consumption lies below the upper current level (LVA).
- Flashing light = The current consumption exceeds the upper current level (LVA).
- Light is out = The current relay has tripped, the feed equipment is stopped.

**Green LED**

The green LED indicates the status of the control voltage.

- Steady light = The control voltage is on.

**Function setting (FS)**

- Memory On / Memory Off.

Function setting “Memory Off” means that the current relay will restart the feed equipment automatically as the current consumption has sunk. The function setting should always be set to “Memory off”.

(Function setting “Memory on” means that restart must be done manually. The function memory on is not used on Conair granulators).

- Undercurrent / Excess current.

The function setting “Excess current” means that the current relay will trip when the current consumption is high. The function setting should always be set to “Excess current”.

(Function setting “Under current” means that the relay trips when the current consumption is low. The function “Under current” is not used on Conair granulators.)

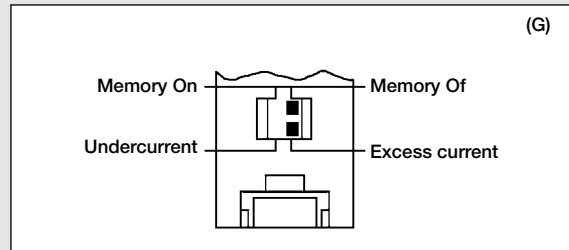
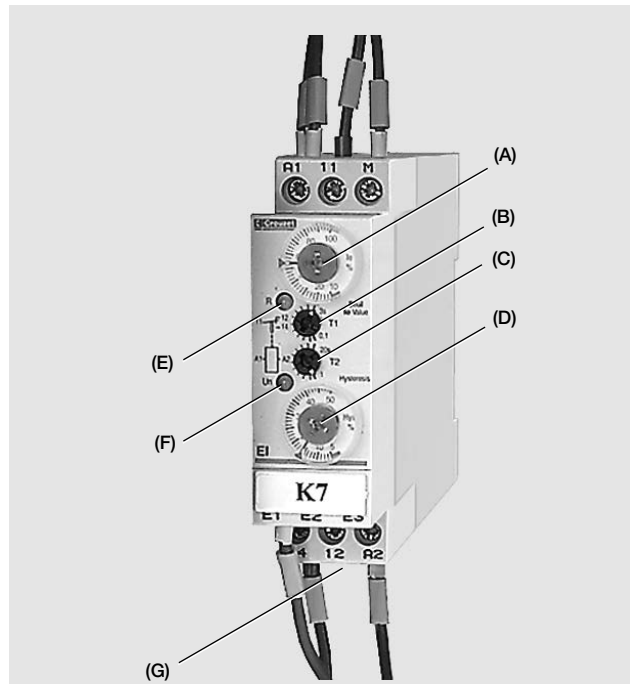

$$\begin{aligned} \text{LVA (Y/D-start)} &= \text{Rated current} / \sqrt{3} \\ \text{LVA (Direct-start)} &= \text{Rated current} \end{aligned}$$

$$\text{LV\%} = \frac{(\text{LVA} \times 100)}{\text{Current transformer size}}$$

$$\text{HA} = \frac{\text{LVA} - (\text{LVA} \times \text{H\%})}{100}$$

- (A) = Limit value percentage, LV%
- (B) = Reaction time, T1
- (C) = Time delay, T2
- (D) = Hysteresis percentage, H%
- (E) = Yellow LED, Current consumption
- (F) = Green LED, Control voltage
- (G) = Function settings

## 2. DESCRIPTION



### Specifications

#### Granulator with standard hand feed hopper

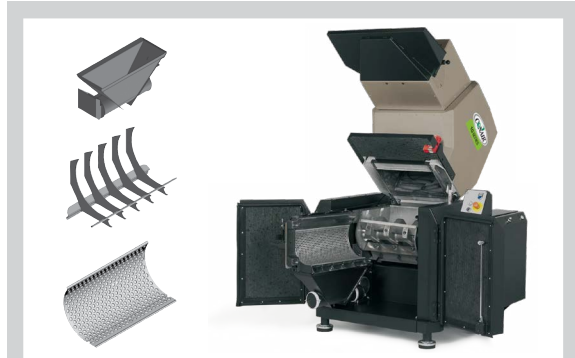
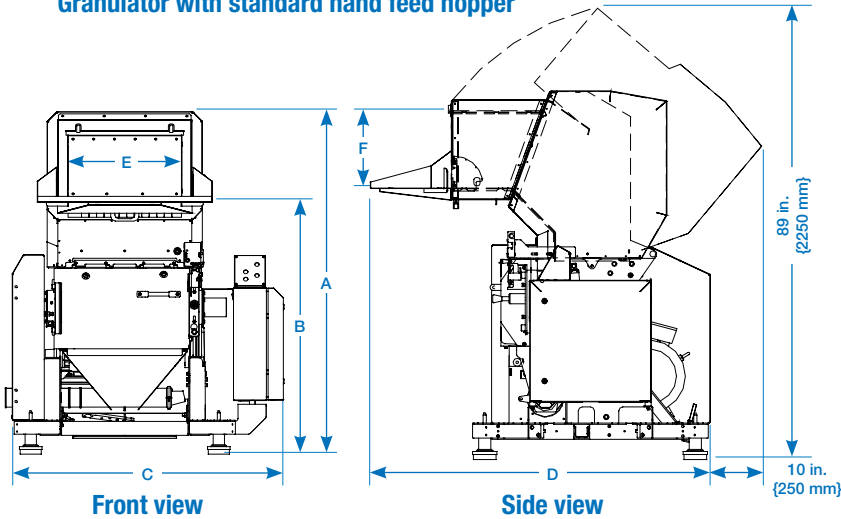

#### Wide open access

Conair's innovative cutting chamber features a swing-open removable screen, cradle and granule discharge bin for the industry's fastest rotor access.

DESCRIPTION

Models	1418	1424	1436
<b>Performance characteristics</b>			
Maximum throughput* lb/hr {kg/hr}	450 {204}	600 {272}	1000 {454}
Super tangential cutter chamber opening inches {mm}	17 x 18 {432 x 457}	17 x 24 {432 x 610}	17 X 36 {432 X 914}
Tangential cutter chamber opening inches {mm}	14 x 18 {356 x 457}	14 x 24 {356 x 610}	14 X 36 {356 X 914}
Rotor speed rpm	540		
Cutting circle inches {mm}	14 {356}		
Motor power † Hp {kW}	10 {7.5}	15 {11.0}	
Rotor type	3-blade open rotor (5-blade open rotor, optional)		
Screen hole sizes inches {mm}	1/8, 1/4, 5/16, 3/8, 1/2, 5/8 and 1 inches {4, 6, 8, 10, 12, 17 and 25 mm}		

<b>Knives</b>	
Number of rotating knives	3
Number of rotating knives	Super tangential 2 standard; Tangential 3 standard
<b>Dimensions inches {mm}</b>	
A - Overall height	72 {1829}
B - Height to hopper infeed	53 {1346}
C - Width	51 {1295}
D - Depth	66 {1677}
E - Feed hopper opening - width	18 {457}
F - Feed hopper opening - height	14 {356}

<b>Approximate weight lb {kg}</b>	
Installed	2094 {950}
Shipping	2315 {1050}

<b>Voltages Full load amps based on motor size ‡</b>					
Motor power Hp {kW}	10 {7.5}	15 {11.2}	25 {18.6}	40 {29.8}	50 {37.3}
208V/3 phase/60 Hz	30.8	46.2	74.8	120.0	150.0 §
230V/3 phase/60 Hz	27.9	41.8	53.7	104.0	130.0
400V/3 phase/50 Hz	16.0	24.0	39.1	62.7	78.2
460V/3 phase/60 Hz	13.9	21.0	34.0	52.0	65.0
575V/3 phase/60 Hz	11.1	16.7	27.1	41.0	52.0

<b>Noise level **</b>	
With standard hopper soundproofing	90 to 95 dbA
With optional base soundproofing	80 to 85 dbA

#### Specification Notes

\* Throughputs are provided as a capacity guideline only. Throughput will be greater or lesser than the values shown according to the selected screen size and the shape, size, thickness and properties of the material to be cut. Consult Conair for a material test to help in determining the correct granulator model for your application.

† The chart lists standard motor selections. Additional motor sizes are listed under Motor Options.

‡ FLA data for reference purposes only. Does not include any accessories added such as blower or conveyor motor loads. Includes main 3Hp motor only. For true, full FLA for power circuit design of specific machine refer to electrical diagram of the machine order or nameplate applied to machine at shipment.

§ Consult factory on availability.

\*\* Noise level will vary according to material type being processed and the granulator configuration. These ranges are based on tests using SPI standards.

Specifications may change without notice. Check with a Conair representative for the most current information.

#### 14 Series Cutter Housing Configurations

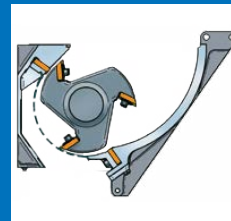

**Super Tangential for bulk waste.** Standard configuration includes two fixed knives. Typical applications are bulky parts and scrap.

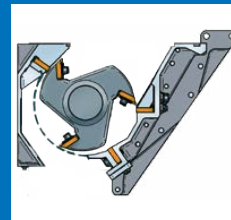

**Tangential for thicker-walled parts.** Three fixed knives are standard on tangential chambers for increased throughputs. Typical applications are thick-walled, heavy-cross section parts and scrap. 3-blade rotor

#### Motor options

● = standard ○ = optional	1418	1424	1436
10.0 Hp {7.5 kW}	●	N/A	N/A
15.0 Hp {11.0 kW}	○	●	●
25.0 Hp {18.7 kW}	○	○	○
40.0 Hp {29.8 kW}	N/A	○	○
50.0 Hp {37.3 kW}	N/A	○	○

#### Evacuation Blower options

○ = optional	1418	1424	1436
1.5 Hp {1.1 kW}	○	N/A	N/A
3.0 Hp {2.2 kW}	○	○	○
5.0 Hp {3.7 kW}	○	○	○

## Transport / Lift

### General rules, Transport / Lift

The machine must only be transported / lifted by trained personnel. All instructions must be observed to avoid machinery damage and personal injury.

### Transport

1. If the machine will be transported exposed to weather and wind: Treat all components that could rust with a rust preventer. Wrap the machine in plastic foil.
2. If the machine will be transported a longer distance or on uneven ground: Fix the machine to a transport pallet with PET straps or tension straps. Transport / lift the pallet with a fork lift.
3. Granulator with wheels: If the machine will be transported a shorter distance on even, dry ground: Transport the granulator with its wheels.

### Lift the granulator

1. Close the granulator. >Page 6:4.
2. Use a fork lift. Insert the forks as shown in figure on the right. Adjust the forks to maximum width. The forks must tangent the inside of the granulator's machine shoes / wheels to prevent the granulator from overbalancing when lifted.
3. Check that no cables or any parts of the safety equipment are pinched.
4. Lift the granulator. For information about machine weight, please refer to page 2:1 "Technical specifications".

### Store the granulator

1. Treat all components that could rust with rust preventer for long-term rust protection.
2. Store the machine in a dry area with even temperature.
3. Rotate the rotor manually every 3 months.

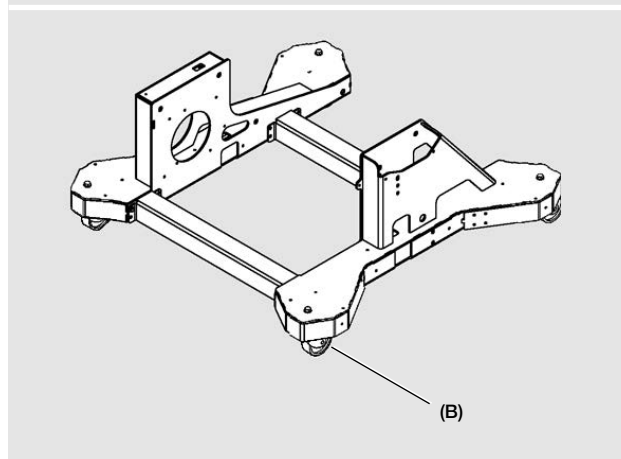
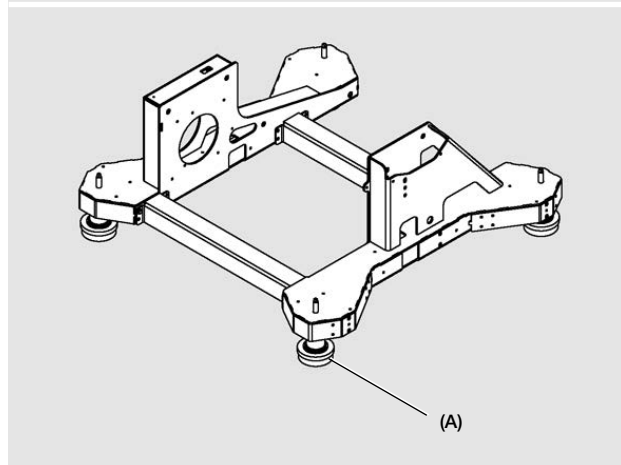
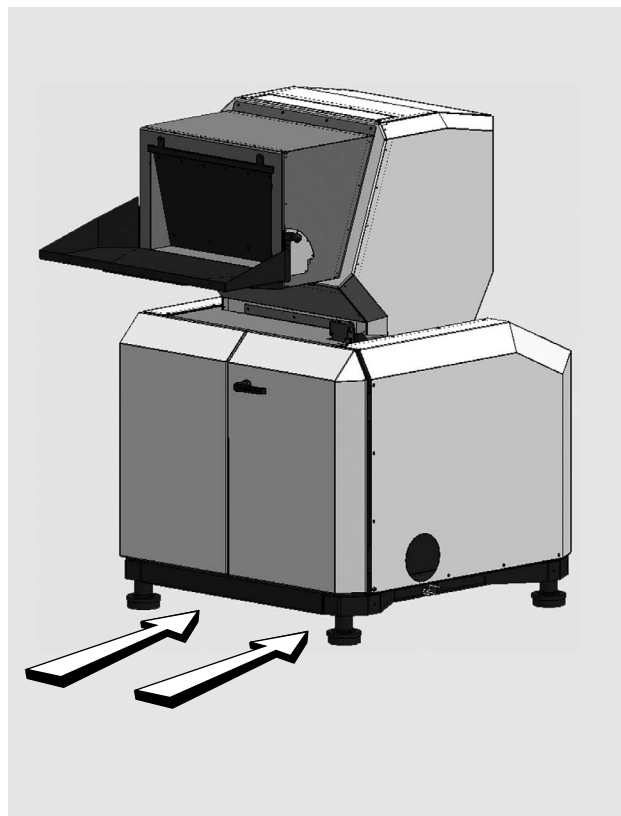

(A) = Machine shoe  
(B) = Wheels

## Before first start

### General rules, Installing

1. Read page 1:2 “Safety rules, During installing”.
2. Read all of chapter 4 before continuing installing.
3. Sign the completed installation, in the end of this chapter.

### Reception inspection

1. Check the packing slip to ensure that the delivery is complete.
2. Check that the machine has not been damaged during transport. Any damage must be reported to the forwarding agents.

### Put the machine in place

1. Please refer to the layout for required space. >Page 2:3 “Layout”.
2. Transport / lift the machine to its working area. >Page 3:1 “Transport / Lift”.
3. Check that the machine stands horizontal and steady.

### Remove the rust preventer

Un-painted components are treated with rust preventer before delivery and transport. Remove the rust preventer before installing and operating the machine.

1. Read page 7:6 “Cleaning”.
2. Clean following parts inside and outside: Hopper, Granule bin, Screen box and Screen. Use a low aromatic alkaline degreaser or a gentle solvent. Wipe clean with lint-free rags.

### Check the knife clearance

1. Check the knife clearance. >Page 7:8 point 13.

### Technical specifications

1. Fill in correct information on page 2:1 “General data, Supplied machine” so that the data corresponds with the machine sign on your supplied machine.
2. Mark the correct alternatives on page 2:1 “General data, 14 Series” so that the data corresponds with your supplied machine.
3. Sign the personnel responsible for the machine’s service and safety on page 2:1.

Before first start (continued from previous)

**Install the hopper**



A granulator with a heavy voluminous hopper may (due to lack of space during transport) be delivered with uninstalled hopper and/or inlet.

The following instructions only applies to granulator that have been delivered with uninstalled hopper and/or inlet.

1. Put the machine in place. >Page 4:1.
2. Open the enclosure (-K). >Page 6:1.
3. Open the cutter housing. >Page 6:2 point 1–3 & 5–8.
4. Install two M16 lifting eyes on top of the hopper.
5. Install a lifting strop in the lifting eyes. Make sure that lifting strop have sufficient capacity to lift the hopper.
6. Lift the hopper on top of the cutter housing. Align the hopper's hinge brackets with the cutter housing's hinge holes.



Note! The front hinge holes is to be used on granulator with cutter housing 1st.

Note! The rear hinge holes is to be used on granulator with cutter housing 5th.

Note! The front hinge holes can be used on granulator with cutter housing 5th if the granulator is provided with enclosure "Front position".

>Page 9:19 "Enclosure".

7. Lower the hopper so that it rests on the cutter housing.
8. Fix the hopper on the cutter housing. Install the clevis pins, the washers and the split pins.
9. The hopper is fixed.



The instruction continues on next page.  
>Page 4:3 "Install the hopper".

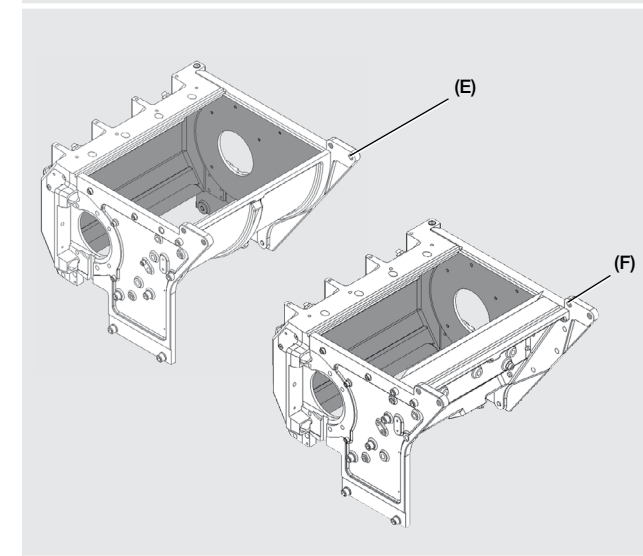
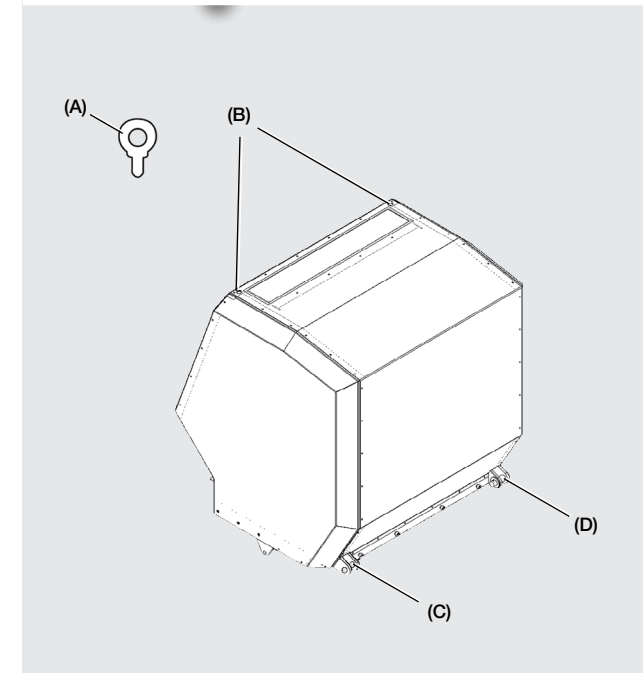
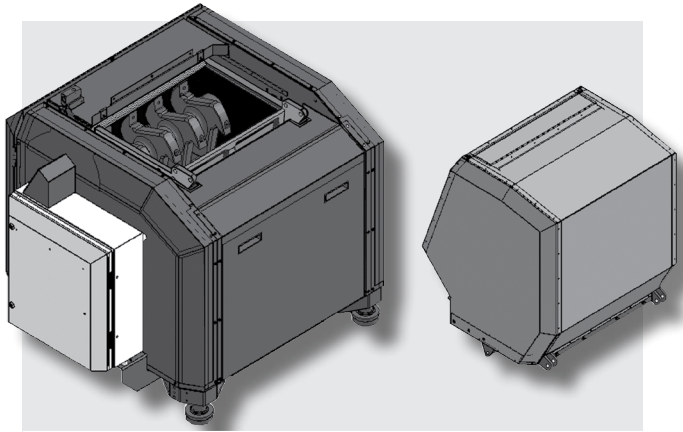

- (A) = Lifting eye
- (B) = Screw holes, Lifting eye
- (C) = Hinge bracket, Hopper
- (D) = Clevis pin & Split pin, Hinge holes
- (E) = Rear hinge hole, Cutter housing 5th
- (F) = Front hinge hole, Cutter housing 1st

Continued

**Before first start (continued from previous)**

**Install the hopper**

10. Before the jack can be installed, the granulator must be connected to the mains.  
>Page 4:4 “Connect the granulator to the mains”.
11. Lift the hopper as shown in figure on the right.
12. Operate the jack. >Page 6:3 “Open a heavy hopper” point a–f. Adjust the jack so that it aligns with the holes in the hopper’s jack bracket.
13. Fix the jack on the hopper. Install the clevis pin, the washer and the split pin.
14. Close the hopper. >Page 6:4 “Close a heavy hopper” point a–d.
15. Remove the hopper’s eye bolts.
16. Connect the safety switch to the electrical cabinet.  
>Page 2:15 “Safety switch”.  
>Please refer to the separate electrical circuit diagram.
17. Install two M12 lifting eyes on top of the inlet.
18. Install a lifting strop in the lifting eyes. Make sure that lifting strop have sufficient capacity to lift the inlet.
19. Lift the inlet.
20. Remove the inlet’s handle, the under plate and the absorber.
21. Move the inlet towards the hopper. Adjust the inlet so that the inlet’s clasps fit into the holes in the hopper.
22. Fix the inlet on the hopper. Tighten the inlet’s tightening screws.
23. Install the inlet’s absorber, the under plate and the handle.
24. Remove the inlet’s eye bolts.
25. Check the flap(s). >Page 7:1.
26. Install the funnel / feed tray (if supplied).  
>Page 2:13 “Inlet / Hopper”.
27. The hopper is installed.

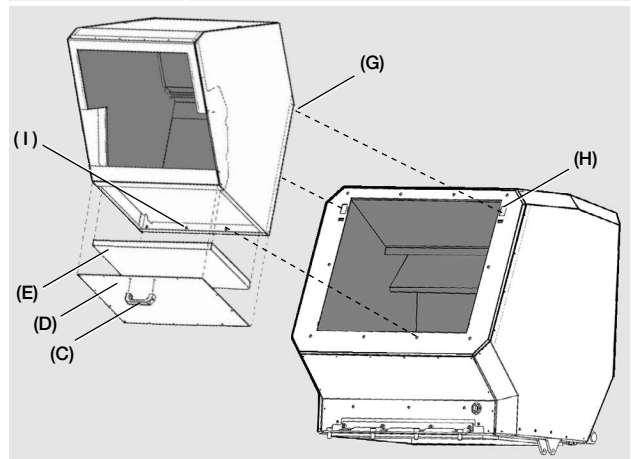
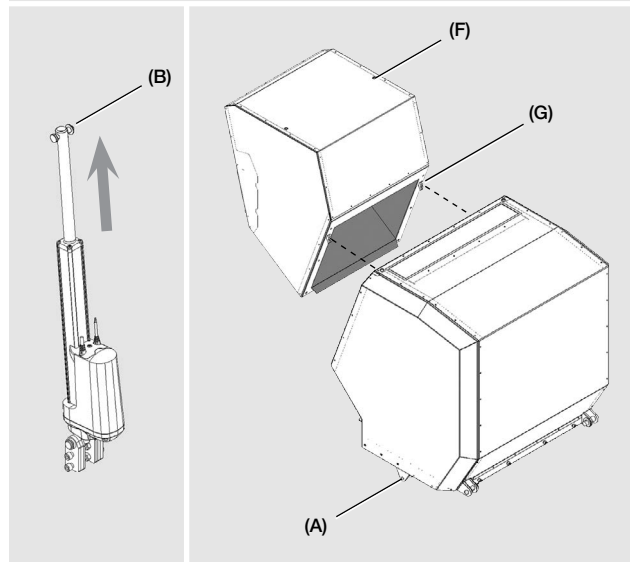
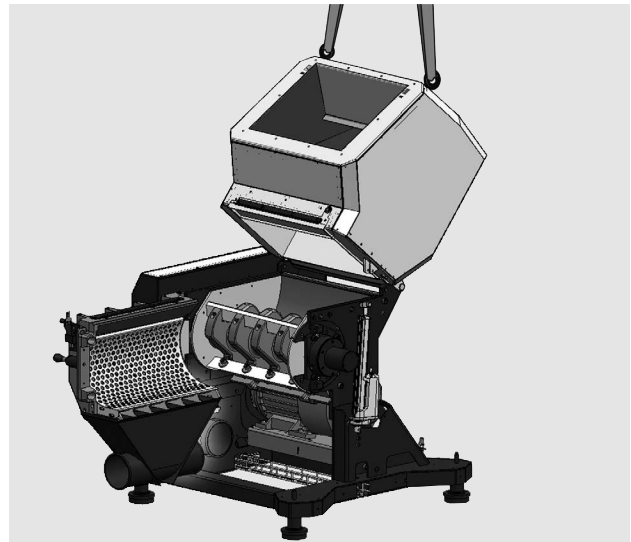

- (A) = Jack bracket, Hopper
- (B) = Clevis pin, Split pin, Washer, Jack
- (C) = Handle, Inlet
- (D) = Under plate, Inlet
- (E) = Absorber, Inlet
- (F) = Screw holes, Lifting eyes
- (G) = Clasp, Inlet
- (H) = Clasp hole, Hopper
- (I) = Tightening screws, Inlet

## Electrical connection

### General rules, Electrical connection

1. Read page 4:1 “General rules, installing”
2. The granulator must be disconnected from the mains before electrical repairs or installing is began.
3. The machine must be installed in accordance to EN 954-1 Category 3. This means that all cables must be installed so that they will not get damaged during operation.
4. When replacing electrical components, only use CONAIR original spare parts. >Page 9:1 “Spare parts”.

### Emergency stop

1. Read page 4:4 “General rules, Electrical connection”
2. Check that the supplied emergency stop is within reach at all positions in the machine’s workplace.
3. If the supplied emergency stop is not accessible from all positions in the workplace, the machine must be provided with further emergency stops.

### Level switch (optional)

1. Adjust the level switch. >Page 7:3.

### Current relay (optional)

1. Adjust the current relay. >Page 7:4.

### Connect the granulator to the mains

1. Read page 4:4 “General rules, Electrical connection”
2. Check the phase sequence of the electric mains with a phase sequence display. The granulator is connected for a right-hand turning field. The electric circuit diagram specifies the connection voltage (Volt) and fuse size (Ampere).
3. Connect the granulator to the mains.

## Start the granulator

1. Check that all actions in page 4:1–4:4 are done.
2. Close the granulator. >Page 6:4.
3. Start the granulator. >Page 5:1.

## Check immediately after first start

1. Check that the rotating direction of the granulator motor corresponds to the arrow on the motor.
2. Additional suffix -U (Blower):  
Check that the blower's rotating direction corresponds to the arrow on the blower.



The blower is functioning even when the rotation direction is wrong, but if the blower's rotating direction is wrong the blower's capacity decreases considerably.

3. If the rotating direction is wrong:
  - a) Stop the granulator. >Page 5:1.
  - b) Read page 4:4 "General rules, Electrical connection".
  - c) Switch over two incoming phases.
  - d) Start the granulator. >Page 5:1.
4. Additional suffix -B (Band conveyor).  
Check the band conveyor. >Page 7:5.
5. Check the emergency stop(s). >Page 7:1.
6. Check the safety equipment. >Page 7:2.

## Check five hours after first start

1. Stop the granulator. >Page 5:1.
2. Check the knife clearance. >Page 7:8 point 14.
3. Check the knives tightening torque.  
>Page 7:8 point 10 "Install the fixed knives".  
>Page 7:9 point 10 "Install the rotating knives".
4. Check the drive belt(s). >Page 7:13.

## Installing complete

The machine has been installed and checked in accordance with the instructions in chapter 4.

Date: ..... / ..... 20 .....

Name: .....

## Start the granulator

1. Read page 1:2 “Safety rules, During start and operation”
2. Check that there is no material in hopper or cutter housing.



Important! The granulator must not be started if there is material left in the hopper and cutter housing. When starting, remaining material may brake the rotor and overload the motor. The overload protection will trip and the granulator will stop.



Important! Granulator with additional suffixes -U (Blower). A granulator with blower must not be started if there is material left in granule bin, outlet pipe or blower. When starting, remaining material in the blower, outlet pipe or granule bin can cause serious and irreparable damage to the blower.

3. Put the main switch in position “1”.
4. Reset the emergency stop(s).
5. Standard 14 Series  
Press the button “Reset safety relay”.

When the Reset safety relay-button has lit up, the granulator is ready to be started.



If the button “Reset safety relay” do not light up, the safety relay has to be checked. >Page 7:3.

6. Start the granulator. Press the start-button.
7. When the start-button has lit up, the granulator is started and ready for operation.



Information! If the granulator or optional equipment does not start once the above points have been attended to, read page 7:15 “Troubleshooting”.

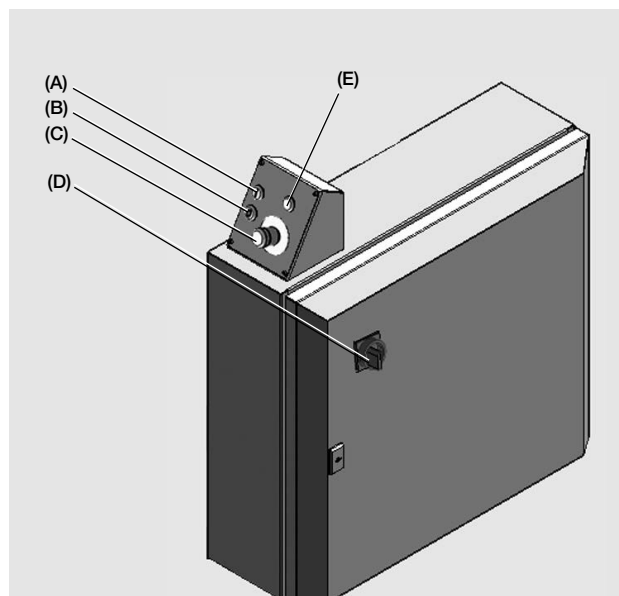

- (A) = Start-button
- (B) = Stop-button
- (C) = Emergency stop
- (D) = Main switch
- (E) = Button, Reset safety relay

## Stop the granulator

1. Stop feeding material. Wait until all material has been fully granulated.



Important! Never stop the granulator until all material in hopper and cutter housing has been fully granulated.



Important! Granulator with additional suffix -U (Blower). A granulator with blower must not be stopped until all material have been transported out of the granule bin and blower.

2. Stop the granulator. Press the stop-button.
3. Press the emergency stop.
4. Lock the main switch in position “0”.
5. The granulator is stopped.

## Open the granulator

### General rules, Open the granulator

1. Read page 1:3 "Safety rules, During service".
2. Additional suffix -B (Band conveyor): Remove the band conveyor.
3. Granulator with feed tray: Fold the feed tray up.

### Open the enclosure (-K)

1. Read page 6:1 "General rules, Open the granulator"
2. Open the enclosure's door/s. Pull the enclosure's handle. Open the door/s 180°
3. Open the enclosure's rear cover. Unscrew the rear cover's tightening screws. Remove the rear cover.
4. The enclosure is opened.

### Open the transmission

1. Read page 6:1 "General rules, Open the granulator"
2. Remove the transmission cover. Unscrew the transmission cover's tightening screws.
3. The transmission is available.

### Close the enclosure (-K)

1. Read page 6:4 "General rules, Close the granulator"
2. Close the cutter housing. >Page 6:5.
3. Close the enclosure's door/s. Pull the enclosure's handle.
4. Close the enclosure's rear cover. Install the rear cover. Tighten the rear cover's tightening screws.
5. The enclosure is closed.

### Close the transmission

1. Read page 6:4 "General rules, Close the granulator"
2. Install the transmission cover. Tighten the transmission cover's tightening screws.
3. The transmission is closed.

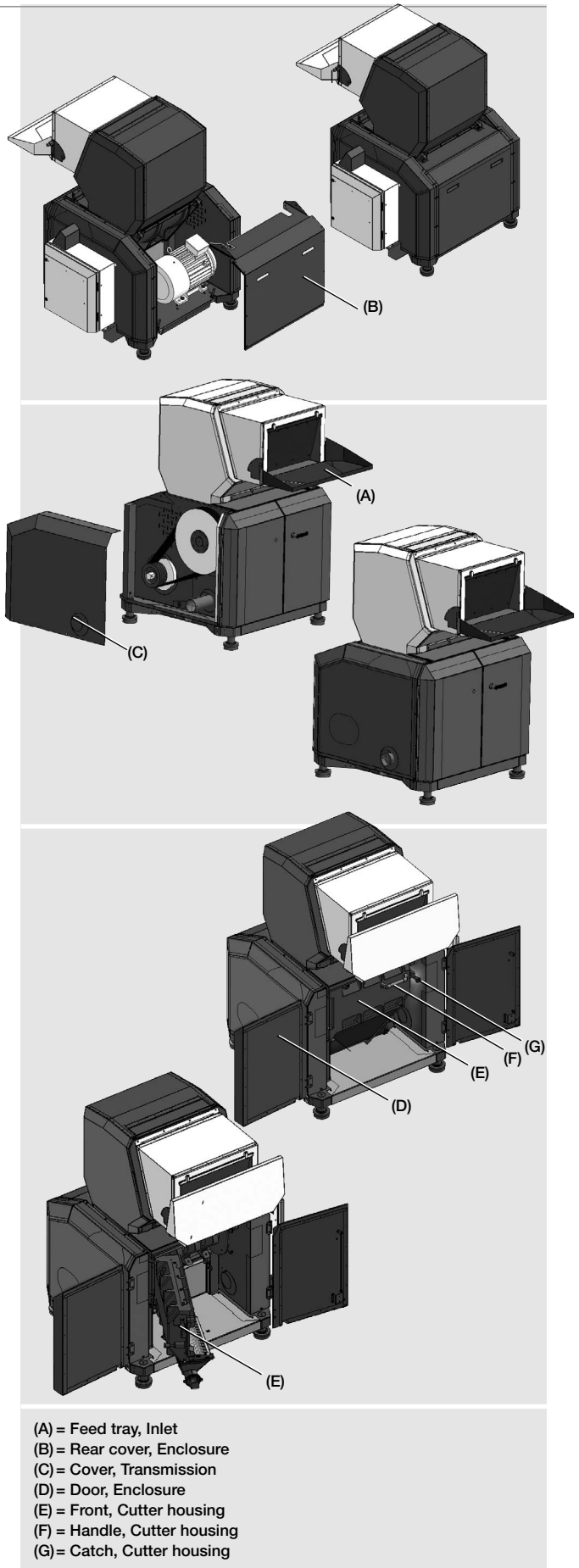

Continued

Open the granulator (continued from previous)

**Open the cutter housing**

1. Read page 6:1 “General”
2. Granulator with additional suffix -K (Enclosure):  
Open the enclosure’s door/s. >Page 6:1 point 2.
3. Remove the granule bin’s quick coupling ring.  
>Page 6:3 image (A).
4. Release the switch key from the safety switch.  
>Page 2:15 “Safety switch”

Standard 14 Series:

- a) Start the granulator’s current supply.  
>Page 5:1 “Start the granulator” point 3–4.
- b) Check that the safety switch’s diode light is lit.  
(The safety switch’s diode light is lit as the rotor stands still.
- c) Remove the switch key from the safety switch.  
Pull the switch key’s handle down. Swing the switch key’s handle to the side.
- d) Stop the granulator’s current supply.  
>Page 5:1 “Stop the granulator” point 3–4.

Solo:

- a) Unscrew the safety switch’s star knob. Unscrew until the switch key is fully released from the safety switch.

5. Loosen the locking bolts. Use a telescope wrench. A telescope wrench is enclosed on delivery.
6. Pull the cutter housing’s catch straight out and then down. Check that the locking bolts can pass through the holes in the lock plate.
7. Swing the cutter housing’s front aside. Pull the cutter housing’s handle until the cutter housing is fully opened.
8. The cutter housing is opened.

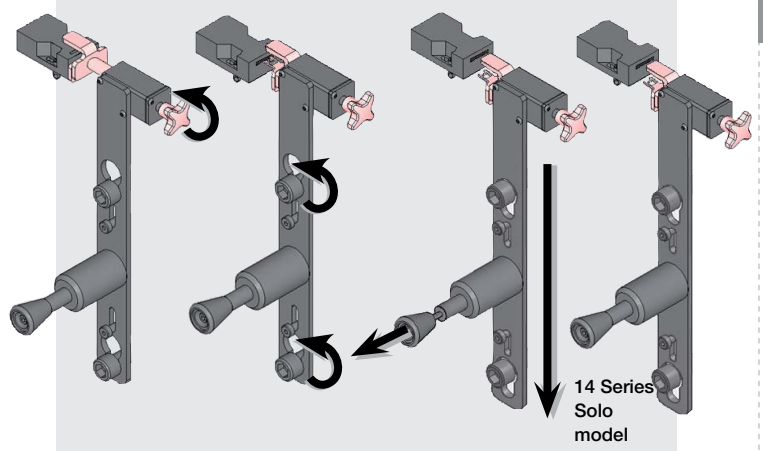
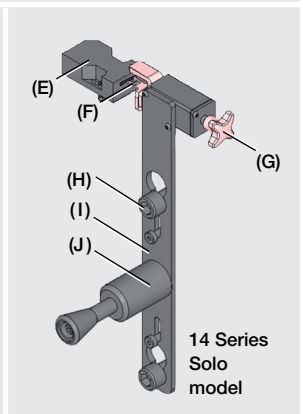
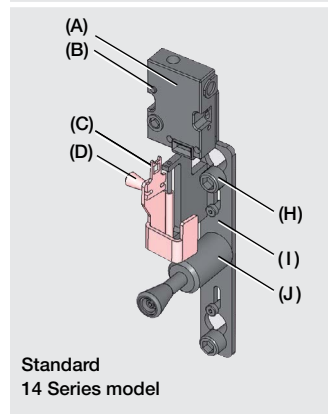
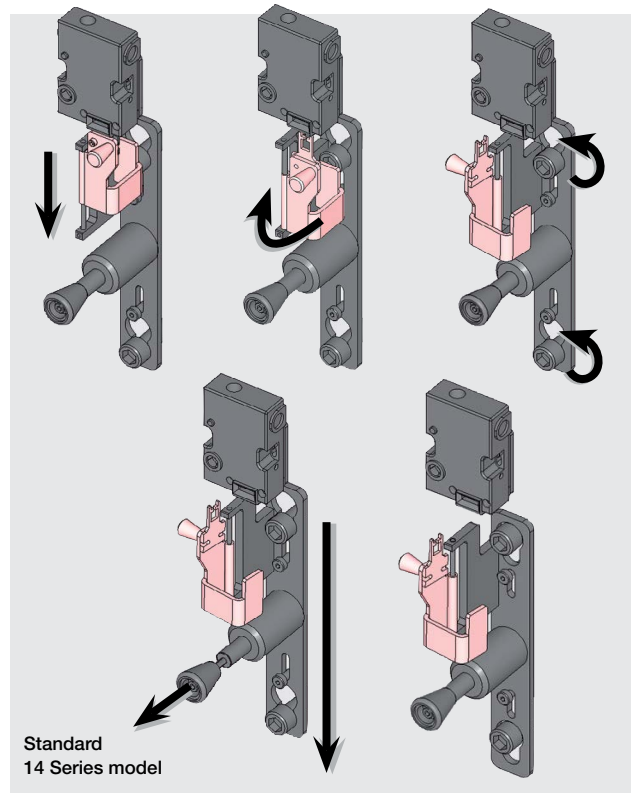

- |  |                             |
|--|-----------------------------|
| (A) = Safety switch, Standard 14 Series      | (F) = Switch key, Solo      |
| (B) = Diode light, Standard 14 Series        | (G) = Star knob, Solo       |
| (C) = Switch key, Standard 14 Series         | (H) = Locking bolts         |
| (D) = Handle, Switch key, Standard 14 Series | (I) = Lock plate            |
| (E) = Safety switch, 14 Series Solo          | (J) = Catch, Cutter housing |

OPEN / CLOSE

Continued

Open the granulator (continued from previous)

**Open the granule bin**

1. Open the cutter housing. >Page 6:2.
2. Remove the granule bin. Move the granule bin along the grooves in the cutter housing's front.
3. The granule bin is opened.

**Open the screen box**

1. Open the granule bin.
2. Remove the screen.
3. Remove the screen box.
4. The screen box is opened.

**Open the hopper**



Information! A granulator with a heavy hopper is opened / closed by means of an electric jack. A granulator with a light hopper is opened /closed manually.

1. Open a heavy hopper:
  - a) Open the cutter housing. >Page 6:2.
  - b) Start the granulator's current supply. >Page 5:1 "Start the granulator" point 3-4.
  - c) Put the knob "Hopper, Close / Open" in position "Open".
  - d) Check that the buttons "Operate 1" and "Operate 2" is lit. (The button "Operate 1" is lit when the rotor stands still. The button "Operate 2" is lit when the cutter housing is opened.)
  - e) At the same time (two hand operation), press the buttons "Operate 1" and "Operate 2". Keep the buttons depressed until the jack has fully opened the hopper.
  - f) Stop granulator's current supply. >Page 5:1 point 3-4.

Open a light hopper:

- a) Open the cutter housing. >Page 6:2.
  - b) Push the hopper upwards. The light hopper is provided with one or two gas springs, to facilitate opening / closing.
2. The hopper is opened.

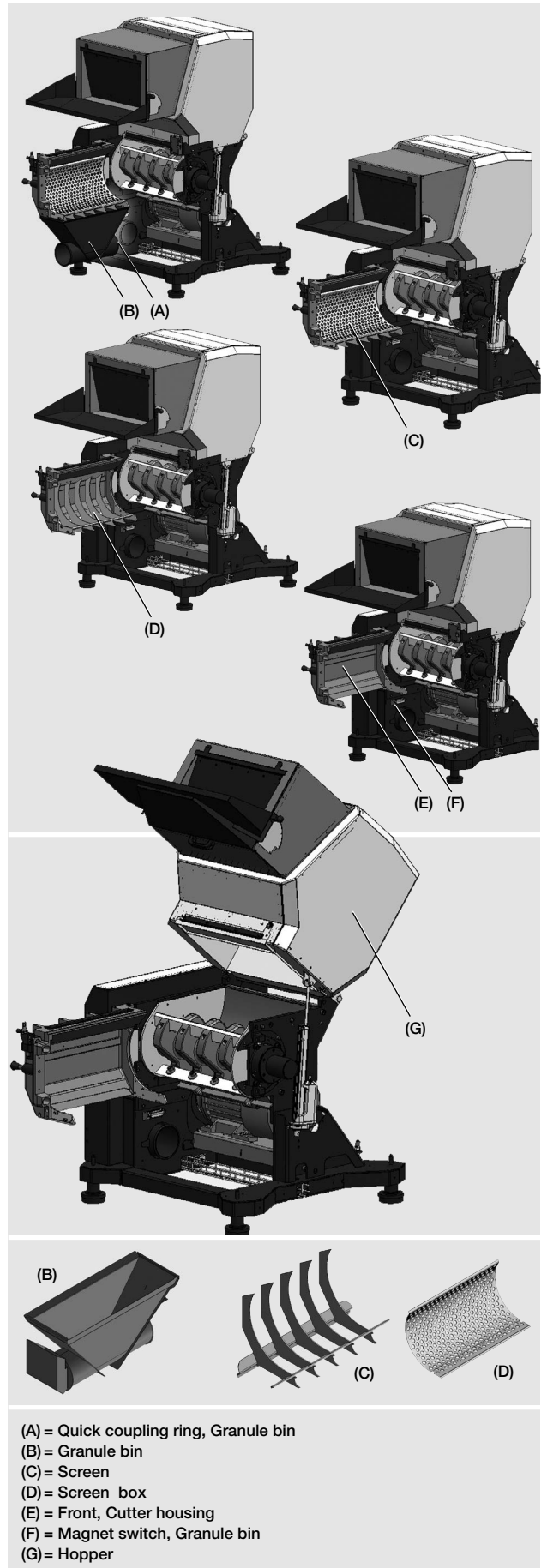

(A) = Quick coupling ring, Granule bin  
 (B) = Granule bin  
 (C) = Screen  
 (D) = Screen box  
 (E) = Front, Cutter housing  
 (F) = Magnet switch, Granule bin  
 (G) = Hopper

## Close the granulator

### General rules, Close the granulator

1. Read page 1:3 “Safety rules, During service”.
2. Check that all surfaces which are going to touch are clean before closing.
3. Additional suffix -B (Band conveyor): After closing the granulator, put the band conveyor close to the granulator’s hopper / inlet.
4. Granulator with feed tray: After closing the granulator, fold the feed tray down.

### Close the hopper



Information! A granulator with a heavy hopper is opened /closed by means of an electric jack. A granulator with a light hopper is opened / closed manually.

1. Read page 6:4 “General rules, Close the granulator.
2. Close a heavy hopper:
  - a) Open the cutter housing. >Page 6:2.
  - b) Start the granulator’s current supply. >Page 5:1 “Start the granulator” point 3–4.
  - c) Put the knob “Hopper, Close / Open” in position “Close”.
  - d) Check that the buttons “Operate1” and “Operate 2” is lit. (The button “Operate 1” is lit when the rotor stands still. The button “Operate 2” is lit when the cutter housing is opened.)
  - e) At the same time (two hand operation), press the buttons “Operate 1” and “Operate 2”. Keep the buttons depressed until the jack has closed the hopper.
  - f) Stop the granulator’s current supply. >Page 5:1 “Stop the granulator” point 3–4.

Close a light hopper:

- a) Open the cutter housing. >Page 6:2.
  - b) Pull the hopper down. The light hopper is provided with one or two gas springs, to facilitate opening / closing.
2. The hopper is closed.

### Close the screen box

1. Read page 6:4 “General rules, Close the granulator.
2. Install the screen box.
3. Install the screen.
4. The screen box is closed.

### Close the granule bin

1. Close the screen box.
2. Install the granule bin. Move the granule bin along the grooves in the cutter housing’s front.
3. The granule bin is closed.

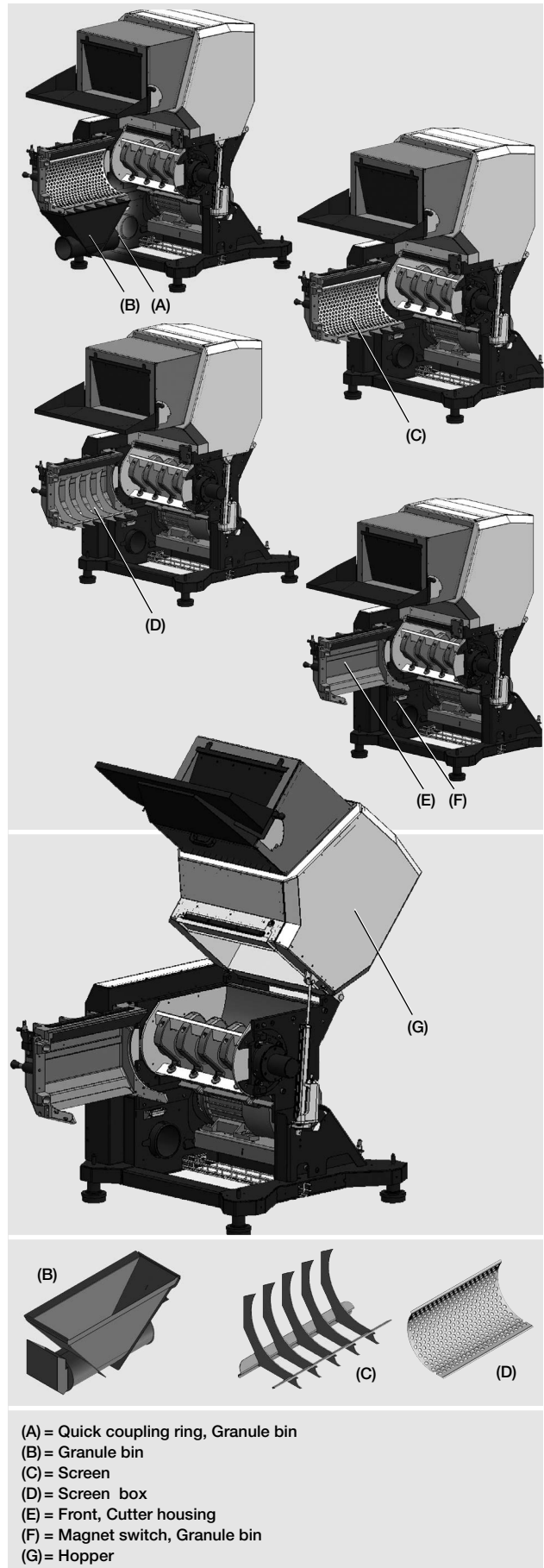

(A) = Quick coupling ring, Granule bin  
 (B) = Granule bin  
 (C) = Screen  
 (D) = Screen box  
 (E) = Front, Cutter housing  
 (F) = Magnet switch, Granule bin  
 (G) = Hopper

Continued

Close the granulator (continued from previous)

**Close the cutter housing**

1. Read page 6:4 “General, Close the granulator”
2. Granulator with additional suffix -K (Enclosure): Close the enclosure’s door/s. >Page 6:1 point 2.
3. Close the hopper. >Page 6:4.
4. Close the granule bin. >Page 6:4.
5. Close the cutter housing’s front. Let the locking bolts pass through the holes in the lock plate. Push the cutter housing’s handle until the cutter housing is closed.
6. Pull the cutter housing’s catch straight out and then up.
7. Tighten the locking bolts. Use a telescope wrench. A telescope wrench is enclosed on delivery.
8. Fit the switch key into the safety switch. >Page 2:15 “Safety switch”.

Standard 14 Series:

- a) Start the granulator’s current supply. >Page 5:1 “Start the granulator” point 3–4.
- b) Check that the safety switch’s diode light is lit. (The safety switch’s diode light is only lit when the rotor stands still).
- c) Swing the switch key’s handle forward. Pull the switch key’s handle up. Fit the switch key into the safety switch.
- d) Stop the granulator’s current supply. >Page 5:1 “Stop the granulator” point 3–4.

Solo:

- a) Tighten the safety switch’s star knob. Fit the switch key into the safety switch. Keep screwing the star knob until it stops moving.

9. Install the granule bin’s quick coupling ring. >Page 6:4 image (A).
10. Check that the granule bin’s magnet switch has mated with the transmission cover’s magnet switch. >Page 2:15 “Magnet switch”.
11. The cutter housing is closed.

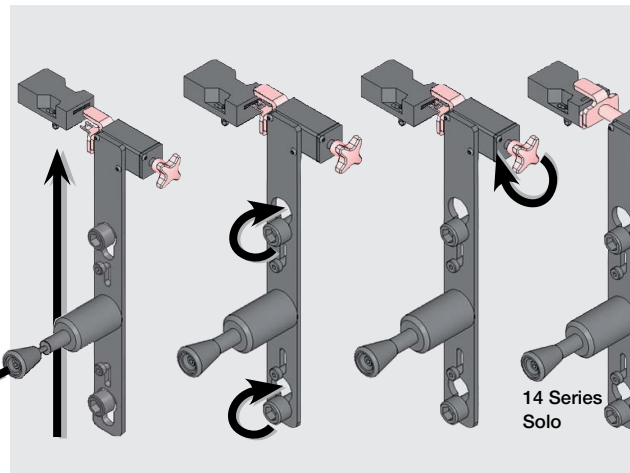
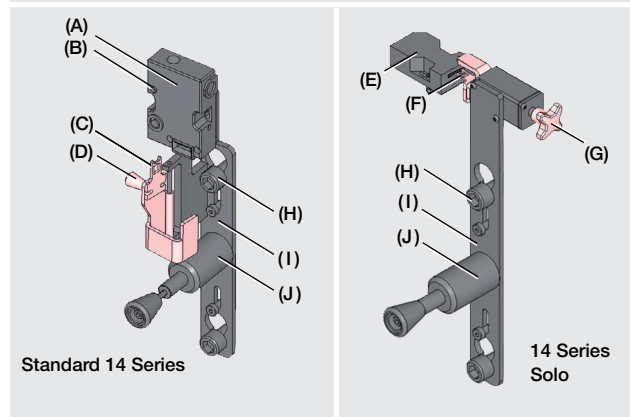
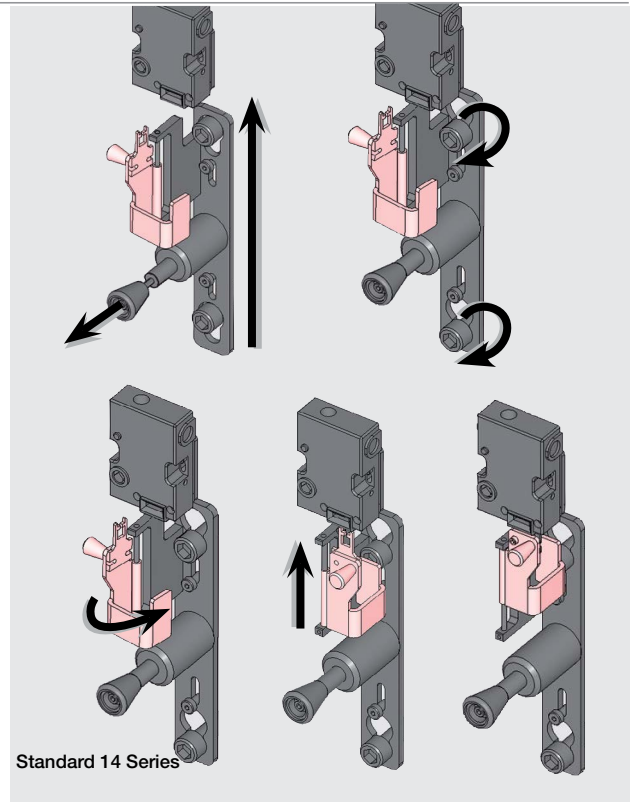

- |  |                             |
|--|-----------------------------|
| (A) = Safety switch, Standard 14 Series      | (F) = Switch key, Solo      |
| (B) = Diode light, Standard 14 Series        | (G) = Star knob, Solo       |
| (C) = Switch key, Standard 14 Series         | (H) = Locking bolts         |
| (D) = Handle, Switch key, Standard 14 Series | (I) = Lock plate            |
| (E) = Safety switch, 14 Series Solo          | (J) = Catch, Cutter housing |

OPEN / CLOSE

## General rules, Service

1. Read page 1:3 "Safety rules, During service".
2. Check / service the machine in accordance with the service schedule.
3. Always sign inspections / service in a service report. Copy the original service report, sign it and save it in a separate service binder. >Page 8:1.

## Emergency stop(s)

1. Read page 7:1 "General rules, Service"
2. Read page 2:14 "Emergency stop(s)". Check the emergency stop(s):
  - a) Start the granulator. >Page 5:1.
  - b) Stop feeding material. Wait until all material has been fully granulated.
  - c) Press the emergency stop. Check that the granulator stops. If the granulator stops, the emergency stop can be reset and the granulator can be restarted.
  - d) **Danger!** If the granulator continues working, although the emergency stop has been pressed, the granulator must be stopped manually at once. >Page 5:1. There is a serious risk of personal injury. Contact the personnel responsible for the machine's service and safety.



## Flap(s)

1. Read page 7:1 "General rules, Service"
2. Read page 2:13 "Flap(s)"
3. Check the flap(s). Change as necessary.

## Lubrication

All bearings in the granulator is lubricated for life and must not be re-greased.

### Service schedule

Interval	Done by	Check
Once every day	Operator	<ul style="list-style-type: none"> <li>• Emergency stop(s)</li> <li>• Flap(s)</li> </ul>
Once every week	Trained personnel	<ul style="list-style-type: none"> <li>• Electrical components</li> <li>• Safety equipment</li> <li>• Safety relay</li> </ul>
Once every month	Trained personnel	<ul style="list-style-type: none"> <li>• Knife sharpness</li> <li>• Knife clearance</li> <li>• Screen</li> </ul>
Once every 6th month	Trained personnel	<ul style="list-style-type: none"> <li>• Drive belt(s)</li> </ul>

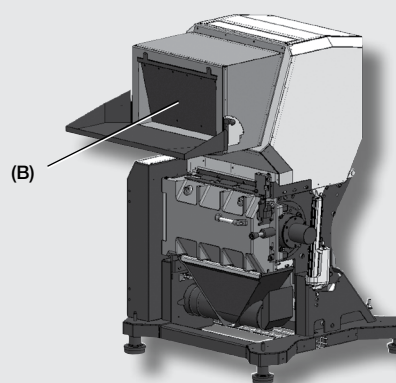
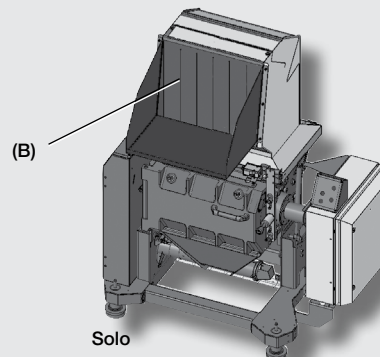
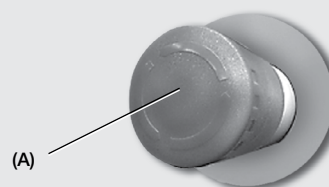

(A) = Emergency stop(s)  
(B) = Flap(s)

## Safety equipment

1. Read page 7:1 “General rules, Service”
2. Read page 2:12 “General rules, Safety equipment”. Check that all parts of the safety equipment are installed.
3. Read page 2:15 “Safety switch”. Check that safety switch(es) is/are functioning:
  - a) Start the granulator. >Page 5:1.
  - b) Stop feeding material. Wait until all material has been fully granulated.
  - c) Standard 14 Series:  
Gently try to release the switch key from the safety switch. >Page 6:2 point 4 c “Standard 14 Series”. Note! It should be impossible to pull down the switch key’s handle.



Danger! If it is possible to release the switch key from the safety switch although the granulator is running, the granulator must be stopped manually at once. >Page 5:1. There is a serious risk of personal injury. Contact the personnel responsible for the machine’s service and safety.

### c) Solo:

Release the switch key from the safety switch.  
>Page 6:2 point 4 a “Solo”.

Check that the granulator stops.



Danger! If the granulator continues working, although the switch key has been released from the safety switch, the granulator must be stopped manually at once. >Page 5:1. There is a serious risk of personal injury. Contact the personnel responsible for the machine’s service and safety.

4. If the safety switch(es) is/are functioning the granulator can be operated again.

## Electrical components

1. Read page 7:1 “General rules, Service”.
2. Read page 4:4 “General rules, Electrical connection”
3. Check all the cables. If there are any damaged or loose cables, connectors or components, authorised personnel must be called at once to do repairs.

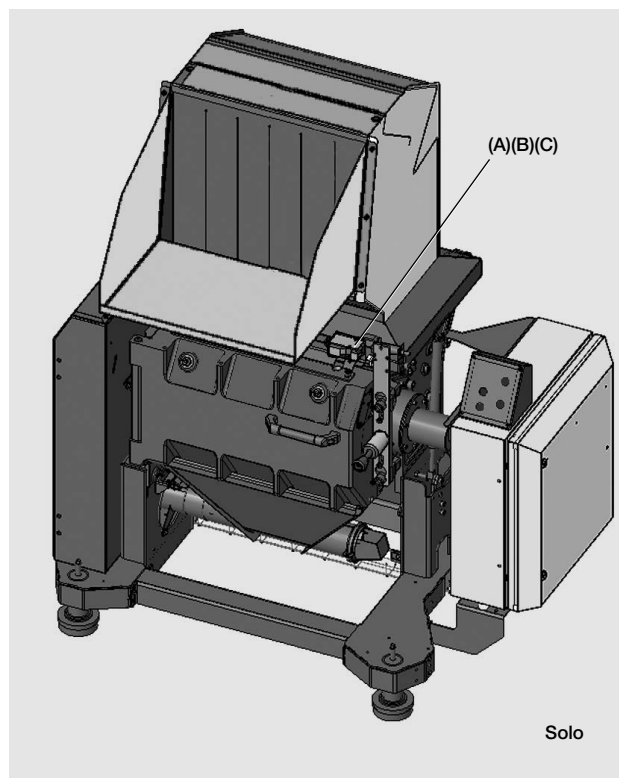

Solo

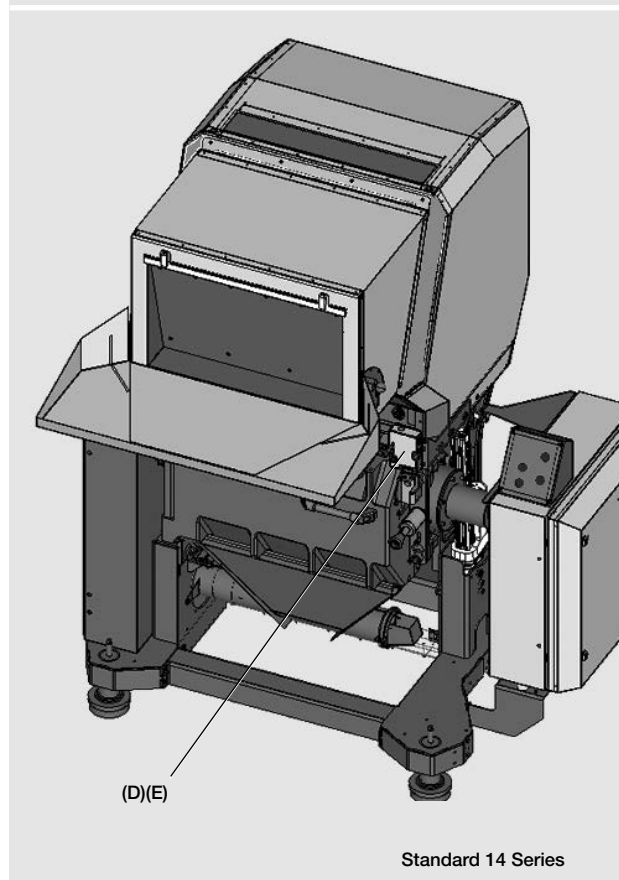

Standard 14 Series

- (A) = Star knob, Solo
- (B) = Safety switch, Solo
- (C) = Switch key, Solo
- (D) = Safety Switch, Standard 14 Series
- (E) = Switch key, Standard 14 Series

## Safety relay

1. Read page 7:1 “General rules, Service”.
2. Read page 2:16 “ Reset safety relay”.
3. Reset the emergency stop(s).
4. Check that the main switch is in position “1”.



Danger! Do not put the main switch in position “0”. (When the main switch is put in position “0” the safety relay-button resets, but a possible failure remains).

5. Press the button “Reset safety relay”.
6. Check that the button “Reset safety relay” is lit.  
If the button “Reset safety relay” lights up, the safety relay is functioning and the granulator can be started.



Danger! If the button “Reset safety relay” do not light up, this indicates a safety failure. There is a serious risk of personal injury. Contact the personnel responsible for the machine’s service and safety.

## Level switch

1. Read page 7:1 “General rules, Service”.
2. Read page 2:17 “Level switch”
3. Open the granule bin. >Page 6:3.
4. Adjust the level switch’s sensitivity.

Level switch, paddle type:

- a) Unscrew the level switch’s cover.
- b) Adjust the torsion spring. Use a pair of needle nosed pliers or a tweezers.



To decrease the sensitivity – Move the torsion spring to the left.

To increase the sensitivity – Move the torsion spring to the right.

- c) Close the level switch’s cover.

5. Close the granule bin. >Page 6:4.
6. Close the cutter housing. >Page 6:5.

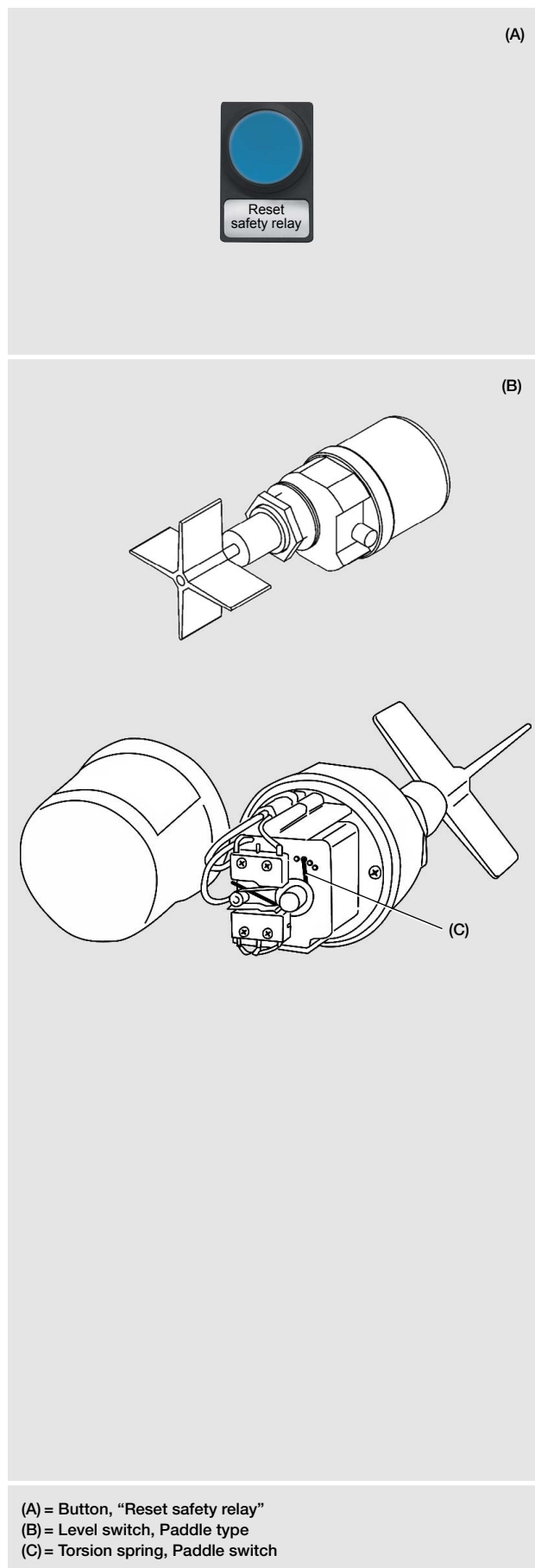

### Current relay

1. Read page 7:1 “General rules, Service”.
2. Read page 2:18 “Current relay”
3. Set the wanted reaction time (T1).
4. Set the time delay during start up (T2) to 0 sec.
5. Check following points in the electrical circuit diagram:
  - Rated current.
  - Current transformer size.
  - Y/D-start or Direct-start.
6. Calculate the limit value in Ampere (LVA).
7. Calculate the limit value percentage (LV%). Set the limit value percentage.
8. Set the hysteresis percentage (H%). Calculate the hysteresis in Ampere (HA).
9. Set the function settings to “Memory off” and “Excess current”.
10. Start the granulator. >Page 5:1.
11. Check that the current relay setting is satisfying. Adjust as necessary.



Example:

- T1 is set to 3 sec.
- Rated current is 15 A.
- Current transformer’s size is 30 (/1A).
- The granulator is Y/D-started.
- LVA is calculated to 8.7 A  
 $8.7 A = 15 / \sqrt{3}$
- LV% is calculated and set to 29%  
 $29\% = \frac{8.7 \times 100}{30}$
- H% is set to 20%.
- HA is calculated to 6.96 A.  
 $6.96 A = \frac{8.7 - (8.7 \times 20)}{100}$
- Function setting is set to “Without memory” and “Excess current”.

The settings in the example means:

During operation, the relay will trip and stop the feed equipment if the granulator’s current consumption exceeds 8.7 A for over 3 seconds.

The function setting “Without memory” enables the relay to restart the feed equipment when the granulator’s current consumption has sunk to 6.96 A.

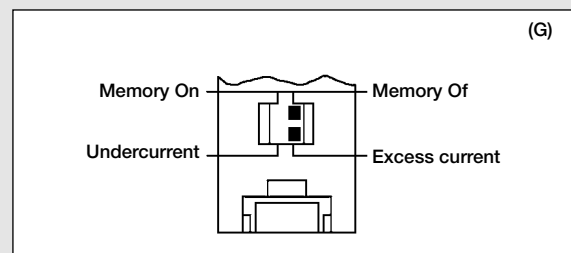
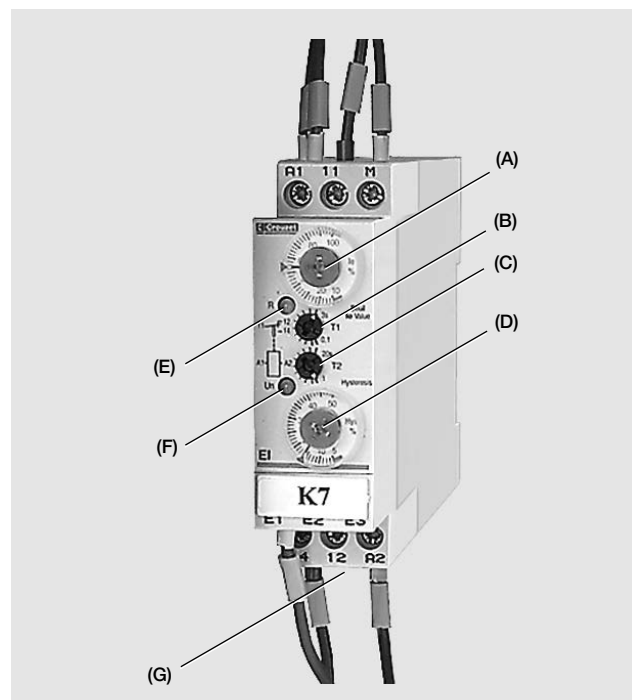

$$\begin{aligned} \text{LVA (Y/D-start)} &= \text{Rated current} / \sqrt{3} \\ \text{LVA (Direct-start)} &= \text{Rated current} \end{aligned}$$

$$\text{LV\%} = \frac{(\text{LVA} \times 100)}{\text{Current transformer size}}$$

$$\text{HA} = \frac{\text{LVA} - (\text{LVA} \times \text{H\%})}{100}$$

- (A) = Limit value percentage, LV%
- (B) = Reaction time, T1
- (C) = Time delay during start up, T2
- (D) = Hysteresis percentage, H%
- (E) = Indicator light, Current consumption
- (F) = Indicator light, Current relay
- (G) = Function settings

## Band conveyor

1. Read page 7:1 “General rules, Service”
  2. Read page 2:7 “Additional suffix -B”.
  3. Check the band’s rotation direction.  
If the rotation direction is wrong:
    - a) Stop the granulator. >Page 5:2.
    - b) Read page 4:4 “General rules, Electrical connection”.
    - c) Switch over two incoming phases.
    - d) Start the granulator. >Page 5:1.
  4. Check that the band runs straight.  
If the band runs obliquely:
    - a) Stop the band conveyor.
    - b) Open the covers at the band’s turn drum.
    - c) Adjust the band’s adjusting screws a 1/4 turn at a time.
    - d) Start the band conveyor. Let the band run for a few minutes. Check that the band runs straight.  
If the band still runs obliquely, repeat point 4 a–d until the band runs straight.
-  Note! The band’s length has a tolerance of 1%. The adjusting screws’ tightening torque must never exceed 5 Nm.
5. Close the covers at the band’s turn drum.

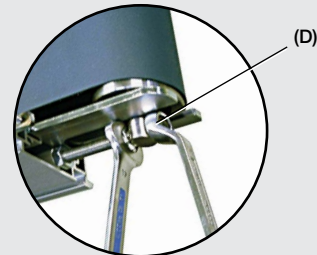
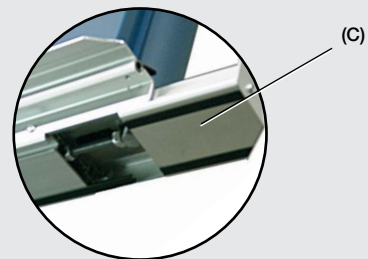
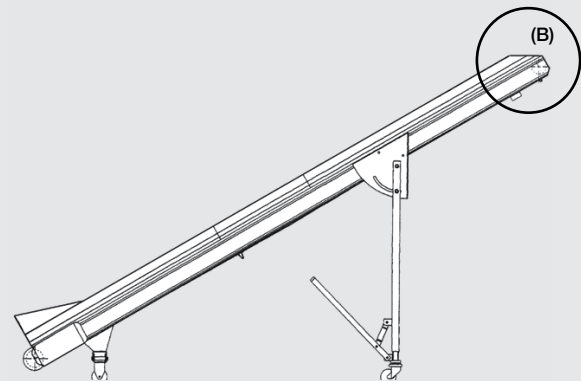
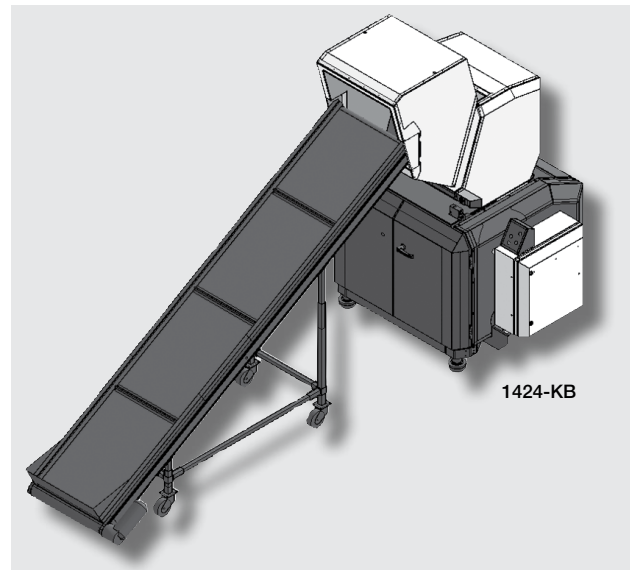

- (A) = Star knob  
 (B) = Turn drum, Band conveyor  
 (C) = Cover, Turn drum  
 (D) = Adjusting screws, Band conveyor

## Cleaning

1. Read page 7:1 “General rules, Service”.
2. When granulating material that generates dust:

- ⚠ a) Clean the granulator’s parts once every day or at least once every week.

In normal operation:

- a) Clean the granulator parts at colour change or at least once every 300 hours.

3. Open the granulator. >Page 6:1.
4. Clean the granulator parts. Use a vacuum cleaner. Clean following parts inside and outside: Funnel / Feed tray, Inlet, Hopper, Flap(s), Cutter housing, Screen, Screen box, Granule bin and Enclosure.

- ⚠ Important! Do not use compressed air and a blow gun, since granulate and plastic residue could be blown into safety switches. Granulate and plastic residue material blown to the floor makes the floor slippery.

5. Additional suffix -U (Blower). Clean the blower, outlet pipe and granule bin very carefully. Use a vacuum cleaner.

- ⚠ Important! When starting, remaining material in the blower, outlet pipe or granule bin can cause serious or irreparable damage to the blower.

6. Additional suffix -B (Band conveyor). Clean the band. Use a gentle detergent. Strong detergents can damage the band. Wipe clean with lint-free rags.

7. Close the granulator. >Page 6:4.

- ⚠ Important! If the rotor is stuck, rotate the rotor in the reverse direction, if necessary tap carefully with a piece of wood. Never use any metal object when you try to release the rotor.

- ⚠ Important! If the hopper, cutter housing, screen box and/or granule bin are filled with compact, hardened plastic residue - a so-called melt-down - the local Conair distributor or Conair Main Office must be contacted for service.

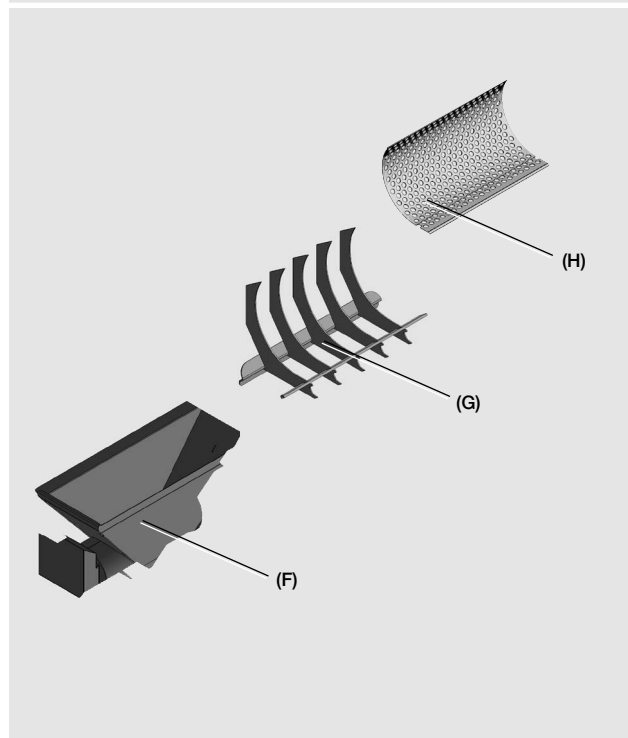
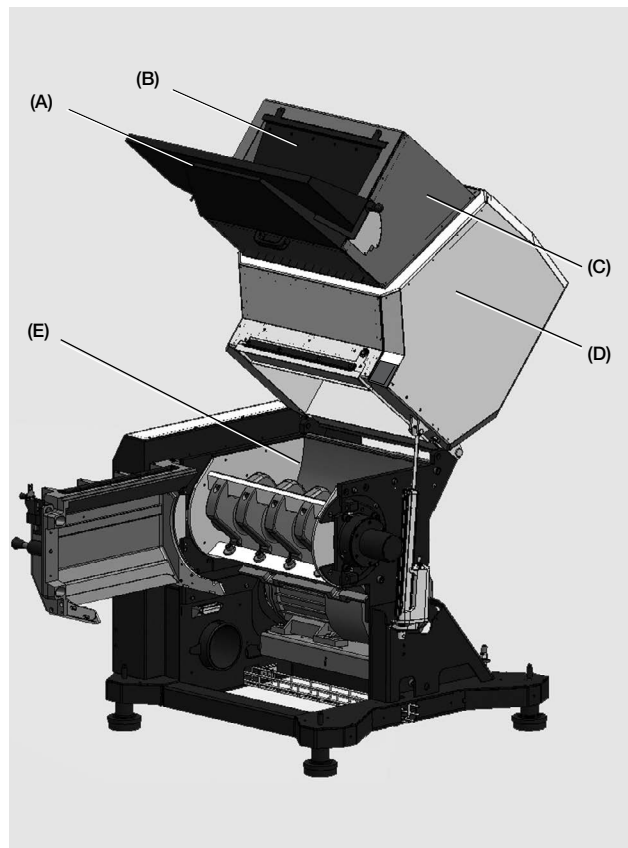

- (A) = Feed tray  
 (B) = Flap(s)  
 (C) = Inlet  
 (D) = Hopper  
 (E) = Cutter housing  
 (F) = Granule bin  
 (G) = Screen box  
 (H) = Screen

## Knives

### General rules, Knives

1. Read page 7:1 “General rules, Service”.
2. Read page 2:8 “Rotor” and “Rotating knives”.
3. Read page 2:9 “Cutter housing” and “Fixed knives”
4. Read page 2:10 “Knife grinding fixture”, “Knife clearance” and “Knife setting fixture”.

### Remove the rotating knives

1. Read page 7:7 “General rules, Knives”.
2. Open the cutter housing. >Page 6:2.
3. Open the hopper. >Page 6:3.
4. Remove the knives on one knife row at the time.
5. Rotate the rotor to an appropriate position. Lock the rotor’s position with a piece of wood.
6. Unscrew the rotating knife’s tightening screws.
7. Remove the rotating knife’s washers.
8. Remove the rotating knife.
9. Repeat point 5–8 until all rotating knives have been removed.

### Remove the fixed knives

1. Remove the rotating knives.
  2. Remove the fixed knife on one side at the time.
  3. Mark the fixed knife’s tightening screws with a marker pen.
- ⚠ Note! The tightening screws must not be mixed up when re-installing.
4. Unscrew the fixed knife’s tightening screws.
  5. Mark the fixed knife’s support rule with a marker pen.  
⚠ Note! The support rules must not be mixed up when reinstalling.
  6. Remove the fixed knife’s support rule.
  7. Remove the fixed knife.
  8. Repeat point 3–7 until all fixed knives have been removed.

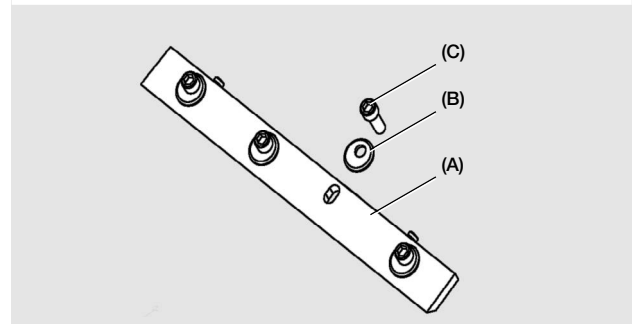
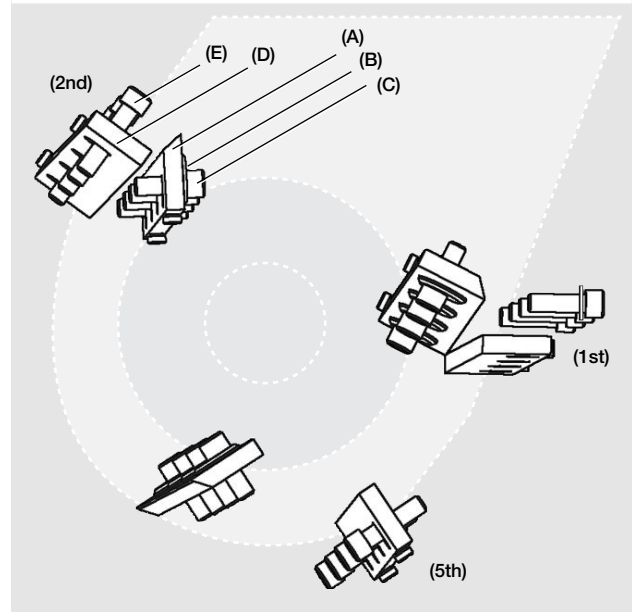
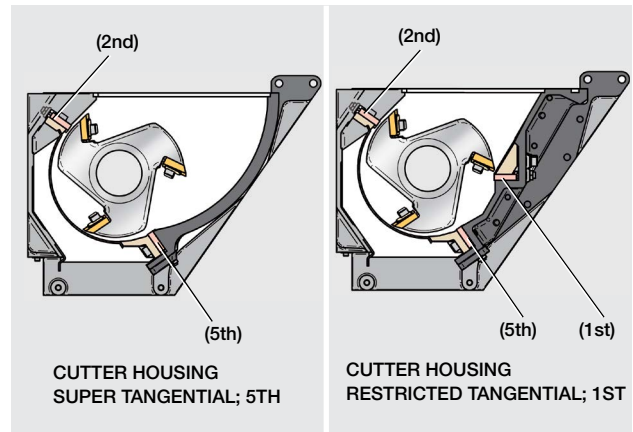

Mark the rotating knife with a marker pen:



- = Knife clearance is correct.
- = Tightening screws are correctly torqued.
- = Knife clearance has been re-checked and is correct.

- (A) = Rotating knife
- (B) = Washer, Rotating knife
- (C) = Tightening screw, Rotating knife
- (D) = Fixed knife
- (E) = Tightening screw, Fixed knife

Continued



Knives (continued from previous)

**Install the fixed knives**

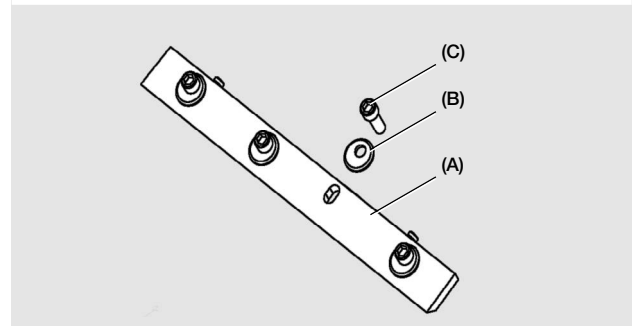
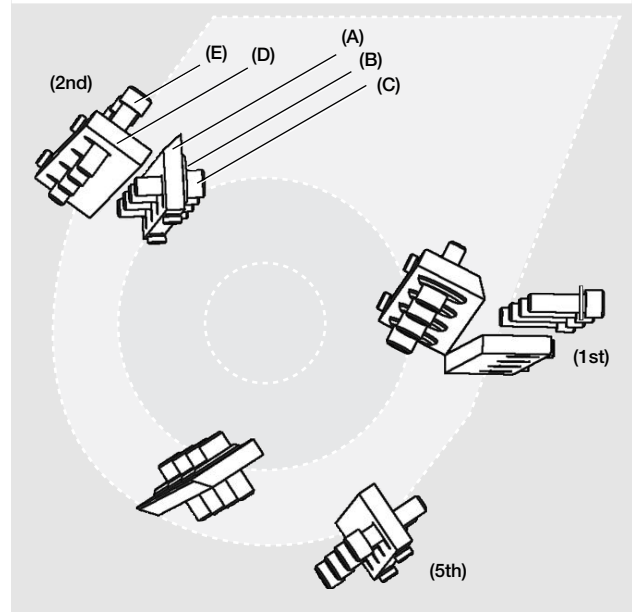
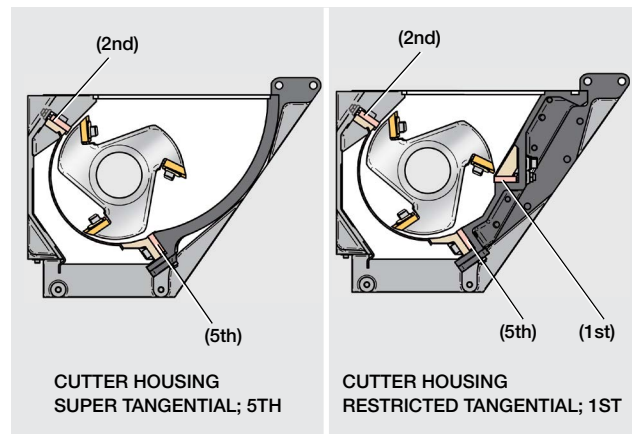
1. Read page 7:7 “General rules, Knives”.
2. Remove the fixed knives. >Page 7:7.
3. Preset the fixed knives. >Page 7:10.
4. Install the front fixed knife (2nd).
5. Rotate the rotor to an appropriate position. Lock the rotor’s position with a piece of wood.
6. Check that the fixed knife’s knife seat is clean.
7. Install the fixed knife. Press the fixed knife firmly against the cutter housing’s grub screws.  
 Note! The setting of the grub screws must never be changed, they are permanently set and glued.
8. Install the fixed knife’s support rule.  
 Note! Check that the appropriate support rule is installed. The support rules must not be mixed up.
9. Install the fixed knife’s tightening screws.  
 Note! Check that the appropriate tightening screws are installed. The tightening screws must not be mixed up.
10. Tighten the fixed knife’s tightening screws. Tightening torque 280 Nm.  
 Note! Note! The tightening screws which tightens the rear fixed knife (1st) must be provided with washers.
11. The front fixed knife (2nd) is installed. Before the remaining rear fixed knife/knives can be installed, all rotating knives must be installed. >Page 7:9.
12. When all rotating knives have been installed, the remaining fixed knife/knives can be installed.
13. Repeat point 5–10 above. Then proceed to point 14.
14. Check the knife clearance. Release the rotor. Rotate the rotor to an appropriate position. Put a feeler gauge between the rear fixed knife and the rotating knife. Put the feeler gauge alternately to the right, to the left and in the middle. Correct knife clearance is 0.008 – 0.016 in {0.20 – 0.40 mm}. Check the knife clearance against one knife row at the time.  
 If the knife clearance is correct: Mark the rotating knife with a marker pen. Draw one more line through the circle:   
 (If the knife clearance is wrong: Adjust the adjusting screws until correct knife clearance is reached. >Page 7:10 “Preset the fixed knife”.)  
 Repeat point 14 until all rotating knives have been marked: 
15. If the cutter housing has three fixed knives, proceed to point 13.  
 If the cutter housing has two fixed knives: Proceed to point 16.
16. All fixed knives (and all rotating knives) are installed.



Mark the rotating knife with a marker pen:

-  = Knife clearance is correct.
-  = Tightening screws are correctly torqued.
-  = Knife clearance has been re-checked and is correct.

- (A) = Rotating knife
- (B) = Washer, Rotating knife
- (C) = Tightening screw, Rotating knife
- (D) = Fixed knife
- (E) = Tightening screw, Fixed knife

Continued

Knives (continued from previous)

**Install the rotating knives**

1. Install the front fixed knife (2nd).  
>Page 7:8 point 1–11.
  2. Preset the knives. >Page 7:10.
  3. Install one rotating knife at the time.
  4. Rotate the rotor to an appropriate position. Lock the rotor's position with a piece of wood.
  5. Check that the rotating knife's knife seat is clean.
  6. Press the rotating knife firmly against the bottom of the knife seat.
  7. Install the rotating knife's washers.
- ⚠ Note! The washers must be installed so that they fully cover the knife's screw holes.
8. Loosely tighten the rotating knife's tightening screws. Note! Every second time knives are changed, the knives must be installed with new tightening screws.
  9. Check the knife clearance. Release the rotor. Rotate the rotor to an appropriate position. Put a feeler gauge between the rotating knife and the front fixed knife. Put the feeler gauge alternately to the right, to the left and in the middle. Correct knife clearance is 0.008 in – .016 in.  
If the knife clearance is correct: Mark the rotating knife with a marker pen. Draw a circle: ○  
(If the knife clearance is wrong: Adjust the adjusting screws until correct knife clearance is reached.  
>Page 7:10 "Preset the rotating knife".)
  10. Tighten the rotating knife's tightening screws. Tightening torque 280 Nm. Mark the rotating knife with a marker pen. Draw a line through the circle: ⊗
  11. Repeat point 4–10 until all rotating knives have been installed.
  12. When all rotating knives have been installed, the rear fixed knife/knives can be installed.  
>Page 7:8 point 12 "Install the fixed knives".

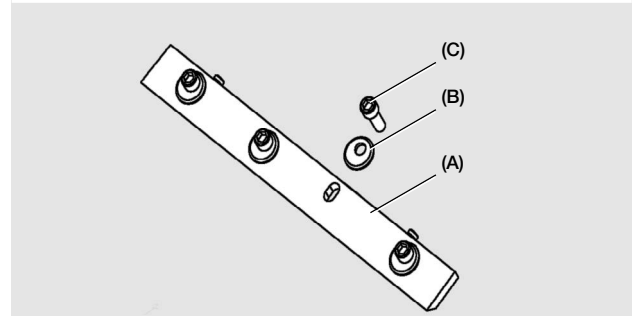
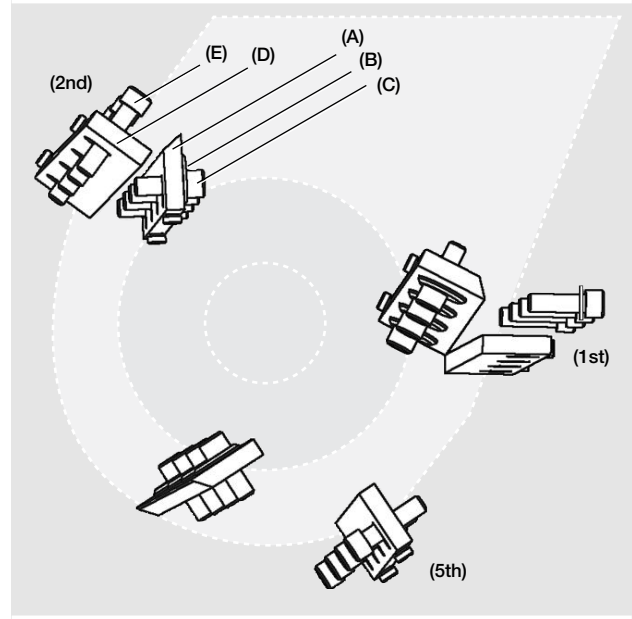
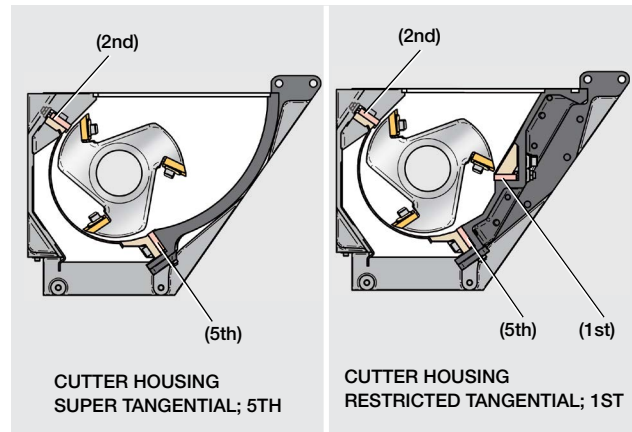

Mark the rotating knife with a marker pen:

- = Knife clearance is correct.
- ⊗ = Tightening screws are correctly torqued.
- ⊗ = Knife clearance has been re-checked and is correct.

- (A) = Rotating knife
- (B) = Washer, Rotating knife
- (C) = Tightening screw, Rotating knife
- (D) = Fixed knife
- (E) = Tightening screw, Fixed knife

## Knives (continued from previous)

### Preset the rotating knives

1. Read page 7:7 “General rules, Knives”.
2. Remove the rotating knives. >Page 7:7.
3. Grind the rotating knives. >Page 7:12.
4. Tighten the rotating knives’ adjusting screws.
5. Install the rotating knife in the knife setting fixture as shown in the upper figure on the right.
6. Put a feeler gauge between the knife setting fixture and the rotating knife’s edge.
7. Adjust the adjusting screws through the holes in the knife setting fixture. Use an allen key.  
Tighten / unscrew until the feeler gauge binds.
8. Gently remove the feeler gauge.
9. Remove the rotating knife.
10. Repeat point 5–9 until all rotating knives are preset.

### Preset the fixed knives

1. Read page 7:7 “General rules, Knives”.
2. Remove the fixed knives. >Page 7:7.
3. Grind the fixed knives. >Page 7:11.
4. Tighten the fixed knives’ adjusting screws.
5. Install the distance in the knife setting fixture as shown in the lower figure on the right.
6. Install the rotating knife in the knife setting fixture as shown in figure on the right.
7. Put a feeler gauge between the knife setting fixture’s distance and the fixed knife’s edge.
8. Adjust the adjusting screws through the holes in the knife setting fixture. Use an allen key.  
Tighten / unscrew until the feeler gauge binds.
9. Gently remove the feeler gauge.
10. Remove the fixed knife.
11. Repeat point 6–10 until all fixed knives are preset.

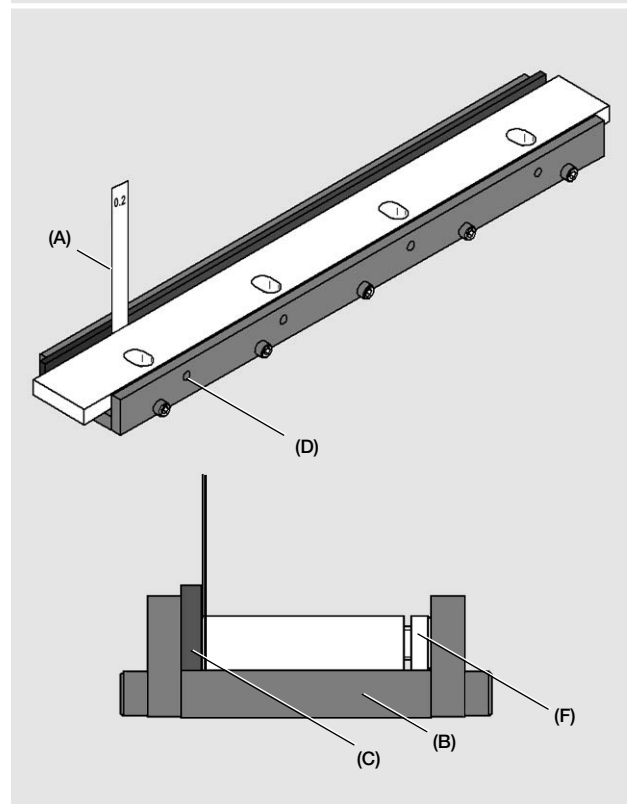
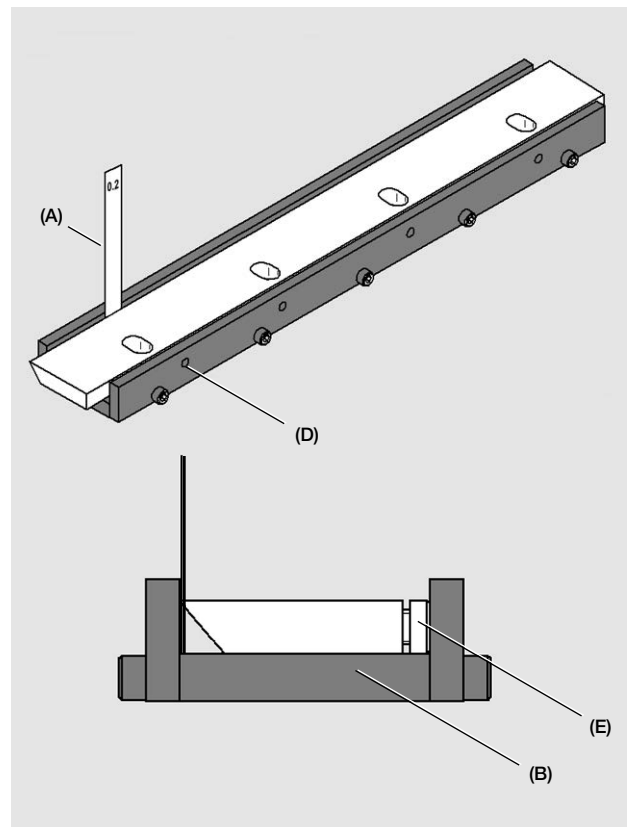

- (A) = Feeler gauge  
 (B) = Knife setting fixture  
 (C) = Distance, Knife setting fixture  
 (D) = Hole, Knife setting fixture  
 (E) = Adjusting screws, Rotating knife  
 (F) = Adjusting screws, Fixed knife

Continued

**Knives (continued from previous)**

**General rules, Grind the knives**

1. Read page 7:1 “General rules, Service”.
2. Always begin grinding the worst and most blunt knife.
3. Grind the knives with accurate precision. It is very important that the relief angle and the cutting angle becomes correct. Respect the specified measures.
4. Always cool the knives during grinding. Grind slowly. Make sure that no heat is developed. Knives that are overheated when grinded, loose their hardness, strength and durability. Knives that have been burned or quenched blue, are irreparable and must be discarded.
5. A surface grinder with magnetic table and a grinding fixture ensures that the cutting angles and the relief angles become correct.

**Grind the fixed knives**

1. Read page 7:11 “General rules, Grind the knives”
2. Remove the fixed knives. >Page 7:7.
3. Unscrew the fixed knives’ adjusting screws.
4. Install the fixed knife in the knife grinding fixture as shown in figure on the right. Tighten the fixed knife with the knife grinding fixture’s tightening screws.
5. Grind the fixed knife’s cutting edge. Use a surface grinder. A correct cutting angle on the fixed knife is 90°. Grind until all irregularities have disappeared.
6. Remove the knife but keep the settings on the surface grinder.
7. Measure the fixed knife’s length after grinding.



Note! If the fixed knife’s length is less than 50 mm, the fixed knife must be discarded and replaced by a new fixed knife.

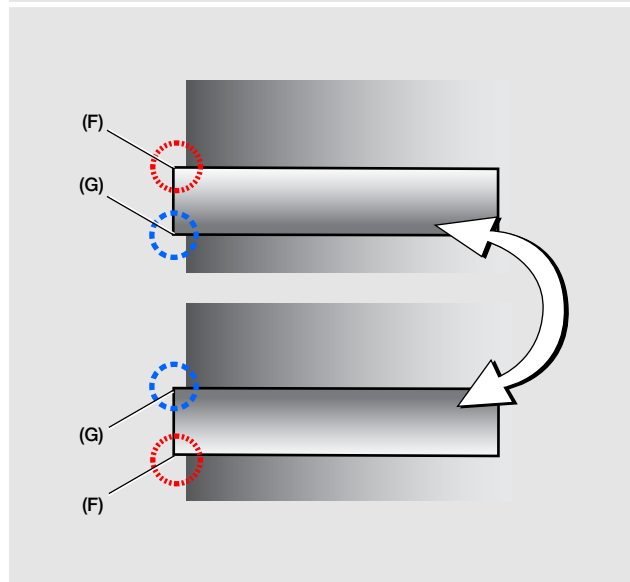
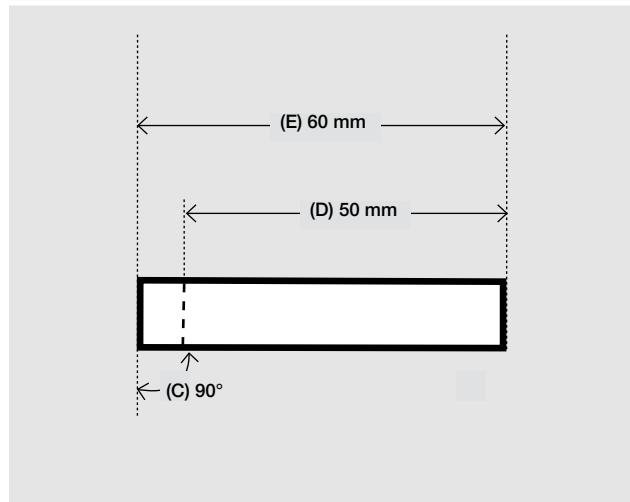
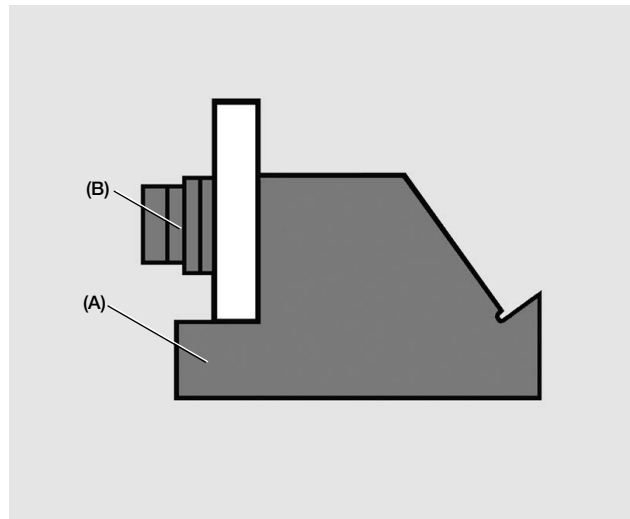

- (A) = Knife grinding fixture
- (B) = Tightening screw, Knife grinding fixture
- (C) = Cutting angle, Fixed knife
- (D) = Minimum length, Grinded fixed knife
- (E) = Length, New fixed knife
- (F) = Cutting edge No1, Reversible fixed knife
- (G) = Cutting edge No2, Reversible fixed knife

Continued

Knives (continued from previous)

**Grind the rotating knives**

1. Read page 7:11 "General rules, Grind the knives"
2. Install the distance in the knife grinding fixture as shown in the upper figure on the right.
3. Install the rotating knife in the knife grinding fixture as shown in the upper figure on the right. Install the knife grinding fixture's washers. Tighten the rotating knife with the knife grinding fixture's tightening screws.
4. Grind the rotating knife's second relief angel. Use a surface grinder. A correct second relief on the rotating knife is 50°. Grind until all irregularities have disappeared.
5. Remove the knife but keep the settings on the surface grinder.



NOTE! All rotating knives must be grinded equally to maintain the rotor balance. The rotating knives must have the same measure and weight (within a gramme).

6. Repeat point 2–5 until all rotating knives' second relief angles have been grinded.
7. Remove the distance from the knife grinding fixture.
8. Install the rotating knife in the knife grinding fixture as shown in the middle figure on the right. Install the knife grinding fixture's washers. Tighten the rotating knife with the knife grinding fixture's tightening screws.
9. Grind the rotating knife's cutting edge and first relief angle. Use a surface grinder. A correct first relief angle on the rotating knife is 55°. Grind until the first relief surface becomes 3 mm.
10. Remove the knife but keep the settings on the surface grinder.
11. Measure the rotating knife's length after grinding.



NOTE! If the rotating knife's length is less than 56 mm, the rotating knife must be discarded and replaced by a new rotating knife.

12. Repeat point 8–11 until all rotating knives' cutting angles have been grinded.

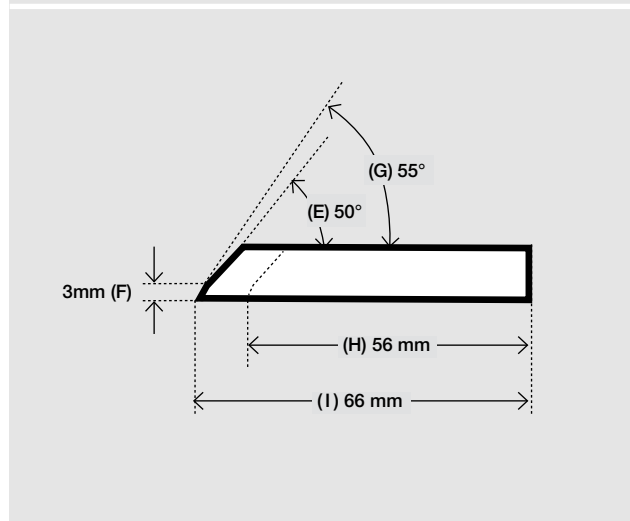
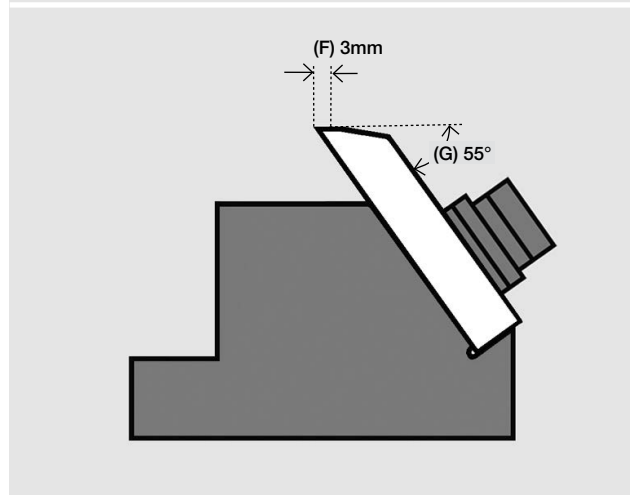
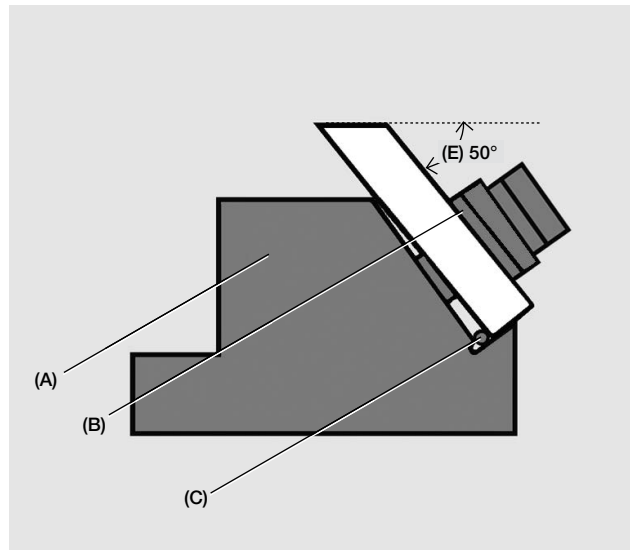

- (A) = Knife grinding fixture
- (B) = Tightening screw, Knife grinding fixture
- (C) = Distance, Knife grinding fixture
- (D) = Cutting edge, Rotating knife
- (E) = First relief angle, Rotating knife
- (F) = First relief surface, Rotating knife
- (G) = Second relief angle, Rotating knife
- (H) = Minimum length, Grinded rotating knife
- (I) = Length, New rotating knife

## Drive belt(s)

### General rules, Drive belt(s)

1. Read page 7:1 “General rules, Service”
2. Read page 2:11 “Transmission”
3. Open the transmission. >Page 6:1.

### Check the drive belts(s)

1. Read page 7:13 “General rules, Drive belt(s)”
2. Check the condition of the drive belt(s). Rotate the rotor pulley a few turns. Check that the drive belt(s) is/are intact and does/do not have any cracks.
3. Check the belt tension. Check one drive belt at the time.
  - a) Load the drive belt in the middle between the rotor pulley and the motor pulley. Load the drive belt with the force specified in the belt tension table on page 7:14.
  - b) Measure the deflection depth. Correct deflection depth is 8 mm.
4. Adjust the belt tension / change drive belt(s) as necessary.
5. Close the transmission. >Page 6:1.

### Adjust the belt tension

1. Granulator with additional suffix -K (Enclosure):  
Open the enclosure’s rear cover.  
>Page 6:1 point 3 “Open the enclosure”.
2. Check the drive belt(s).
3.
  - a) Adjust the motor mounting bracket’s adjusting screws. Tighten / Unscrew the right and the left adjusting screw with equal turns, to ensure that the motor still will be parallel with the rotor.
  - b) Decrease the belt tension - Move the motor mounting bracket upwards.  
or  
Increase the belt tension – Move the motor mounting bracket downwards.
4. Check that the rotor pulley and the motor pulley are in line (tolerance 0.5 mm). Check that the motor and the rotor are parallel. Adjust the motor mounting bracket’s adjusting screws as necessary.
5. Check the belt tension.

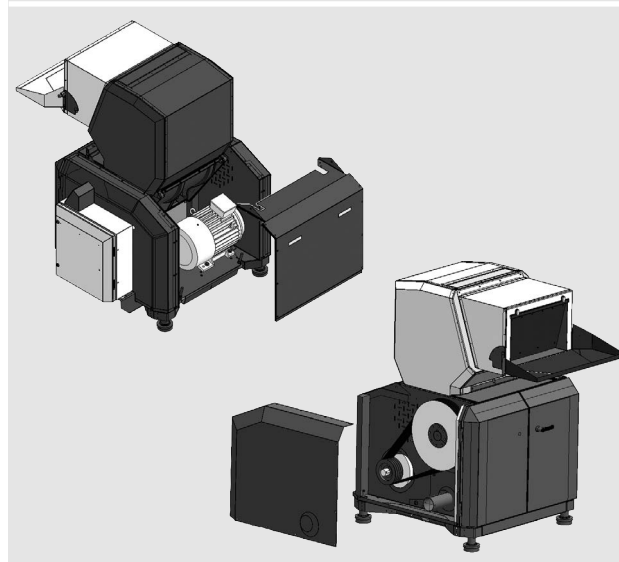
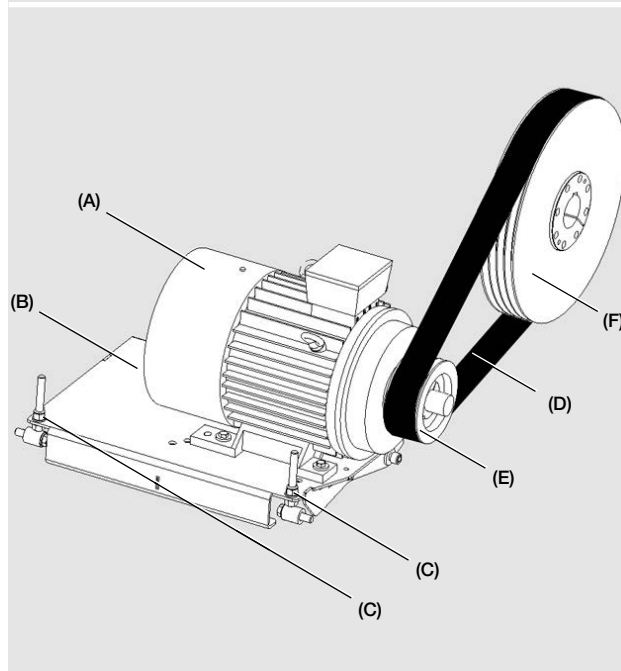
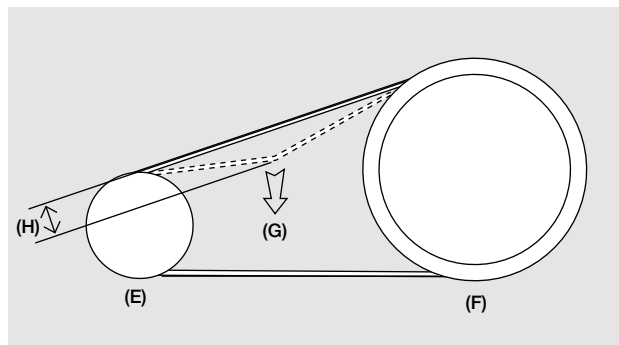

- (A) = Motor  
 (B) = Motor mounting bracket  
 (C) = Adjusting screws, motor mounting bracket  
 (D) = Drive belt(s)  
 (E) = Rotor pulley  
 (F) = Motor pulley  
 (G) = Deflection force  
 (H) = Deflection depth



Note! When drive belts have been adjusted they must be re-checked after 20 hours of operation.

Continued

Drive belt(s) (continued from previous)

**Belt tension table**

Deflection depth 8 mm	10 Hp {7.5 kW}		15 Hp {11 kW}	
	Old drive belt	New drive belt	Old drive belt	New drive belt
50 Hz / 60Hz	N	N	15 N	19 N

Deflection depth 8 mm	25 Hp {18.7 kW}		40 Hp {29.8 kW}	
	Old drive belt	New drive belt	Old drive belt	New drive belt
50 Hz / 60Hz	23 N	30 N	N	N

Deflection depth 8 mm	50 Hp {37.3 kW}	
	Old drive belt	New drive belt
50 Hz / 60Hz	N	N

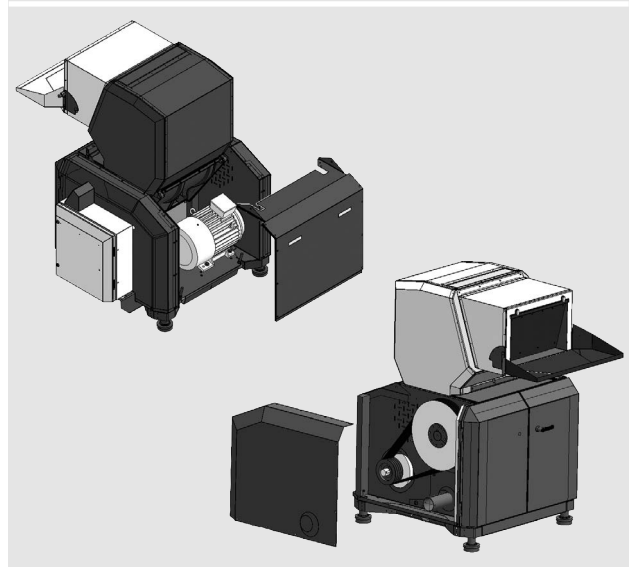
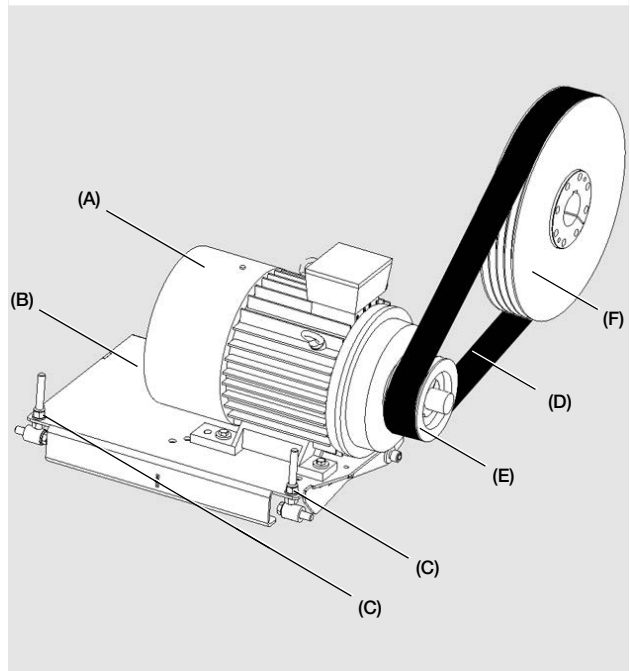
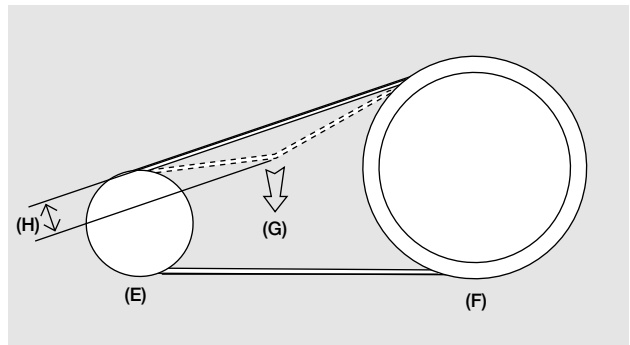

- (A) = Motor
- (B) = Motor mounting bracket
- (C) = Adjusting screws, motor mounting bracket
- (D) = Drive belt(s)
- (E) = Rotor pulley
- (F) = Motor pulley
- (G) = Deflection force
- (H) = Deflection depth

## Troubleshooting

Problem	Probable cause	Solution
The granulator or any optional equipment does not start / stops unexpectedly.	The emergency stop is activated	1. Reset the emergency stop(s). >Page 5:1.
	The granulator / the optional equipment is not connected to the mains.	1. Connect the granulator to the mains. >Page 4:2. 2. Connect the mains plug on the band conveyor to the electrical outlet (Band conveyor = optional).
	The main switch is in position "0".	1. Put the main switch in position "1". >Page 5:1.
	The button "Reset safety relay" has not been pressed.	1. Press the button "Reset safety relay". >Page 5:1 "Start the granulator"
	Screen box, Granule bin, Hopper, Enclosure and/or optional equipment are not properly closed, or their safety switch(es) / star knob(s) is/are open.	1. Close the granulator. >Page 6:2. 2. Check that all safety switches / star knobs are closed. >Page 2:15 "Safety switch" and "Star knob".
	The granulator's overload protection F1 has tripped since the granulator has been overloaded.  or  Band conveyor (optional): The band conveyor's overload protection Q3 has tripped since the band has stuck or the band conveyor has been overloaded.  or  Blower (optional): The blower's overload protection Q2 has tripped since the blower has been overloaded.	1. Reset the overload protection. >Page 2:16 "Overload protection".  Before restart: 2. Clean the granulator. >Page 7:6. 3. Check the drive belt(s). Adjust / change drive belts as necessary. >Page 7:13. 4. Check knife sharpness and knife clearance. >Page 7:8 point 14.
	The level switch (optional) has stopped the granulator / the optional equipment.  or  The level switch's mains plug is disconnected.	1. Check the level switch. >Page 7:4. 2. Connect the mains plug on the level switch.
The current relay has stopped the granulator / the optional equipment.	1. Check the current relay. >Page 7:5.	
The rotor still rotates when the hopper is opened.	The drive belt is worn or the belt tension is wrong.  or  The safety equipment is not functioning.	1. Check the drive belt(s). Adjust / change drive belts as necessary. >Page 7:13. 2. Check the safety equipment. >Page 7:2.
The granulator or some optional equipment does not start after normal fault tracing		1. Lock the main switch in position "0". 2. Press the emergency stop(s). 3. Contact the personnel responsible for the machine's service and safety.







**Service actions, Once every month**

Month ..... 20 ..... Name:.....

**Rotating knife:**  Existing knives are good  Knives and screws are replaced  Support rules are replaced

**Fixed knife:**  Existing knives are good  Knives and screws are replaced  Support rules are replaced

**Screen:**  Existing screen is good  Screen is replaced  **Other remarks:**.....

Month ..... 20 ..... Name:.....

**Rotating knife:**  Existing knives are good  Knives and screws are replaced  Support rules are replaced

**Fixed knife:**  Existing knives are good  Knives and screws are replaced  Support rules are replaced

**Screen:**  Existing screen is good  Screen is replaced  **Other remarks:**.....

Month ..... 20 ..... Name:.....

**Rotating knife:**  Existing knives are good  Knives and screws are replaced  Support rules are replaced

**Fixed knife:**  Existing knives are good  Knives and screws are replaced  Support rules are replaced

**Screen:**  Existing screen is good  Screen is replaced  **Other remarks:**.....

Month ..... 20 ..... Name:.....

**Rotating knife:**  Existing knives are good  Knives and screws are replaced  Support rules are replaced

**Fixed knife:**  Existing knives are good  Knives and screws are replaced  Support rules are replaced

**Screen:**  Existing screen is good  Screen is replaced  **Other remarks:**.....

Month ..... 20 ..... Name:.....

**Rotating knife:**  Existing knives are good  Knives and screws are replaced  Support rules are replaced

**Fixed knife:**  Existing knives are good  Knives and screws are replaced  Support rules are replaced

**Screen:**  Existing screen is good  Screen is replaced  **Other remarks:**.....

Month ..... 20 ..... Name:.....

**Rotating knife:**  Existing knives are good  Knives and screws are replaced  Support rules are replaced

**Fixed knife:**  Existing knives are good  Knives and screws are replaced  Support rules are replaced

**Screen:**  Existing screen is good  Screen is replaced  **Other remarks:**.....

**Service actions, Once every 6th month**

Date ..... / ..... 20 ..... Name:.....

**Drive belt:** Drive belt(s) and belt tension are good  Belt tension is adjusted  Drive belt(s) is/are replaced



**Other remarks**

Date ..... / ..... 20 ..... Name:.....

Other remarks:.....

Date ..... / ..... 20 ..... Name:.....

Other remarks:.....

Date ..... / ..... 20 ..... Name:.....

Other remarks:.....

Date ..... / ..... 20 ..... Name:.....

Other remarks:.....

Date ..... / ..... 20 ..... Name:.....

Other remarks:.....

Date ..... / ..... 20 ..... Name:.....

Other remarks:.....

Date ..... / ..... 20 ..... Name:.....

Other remarks:.....

Date ..... / ..... 20 ..... Name:.....

Other remarks:.....

Date ..... / ..... 20 ..... Name:.....

Other remarks:.....

Date ..... / ..... 20 ..... Name:.....

Other remarks:.....

Date ..... / ..... 20 ..... Name:.....

Other remarks:.....

Date ..... / ..... 20 ..... Name:.....

Other remarks:.....

Date ..... / ..... 20 ..... Name:.....

Other remarks:.....

**General**



Note! When replacing machinery parts, only use Conair original spare parts. Spare parts orders should be sent to Conair's Parts (1-800-458-1960, outside of the United States, call: 814-437-6861). The following must be specified when spare parts are ordered:

- Manufacturing No according to the machine's type plate.
- Machine type according to the machine's type plate.
- Manufacturing year.
- Part description, Specification, Article No and Q according to this spare part catalog.

The performance of Your supplied machine can vary from the standard machines described in this instruction manual. If there are any questions, please contact Conair's local distributor or Conair's main office.

**Overview**

Feed tray, Funnel.....9:2  
 Inlet .....9:3  
 Flap(s) .....9:4  
 Hopper.....9:5  
 Hopper Device .....9:6  
 Safety Hopper & Cutter housing.....9:7  
 Cutter housing.....9:9  
 Rotor .....9:11  
 Knives .....9:12  
 Screen box, Screen.....9:14  
 Granule bin, Discharge .....9:15  
 Transmission, Motor, Flywheel .....9:16  
 Safety Transmission.....9:18  
 Safety Enclosure .....9:19  
 Safety Electrical cabinet .....9:21  
 Body.....9:22  
 Options.....9:23  
 Material transport.....9:24  
 Blower.....9:25

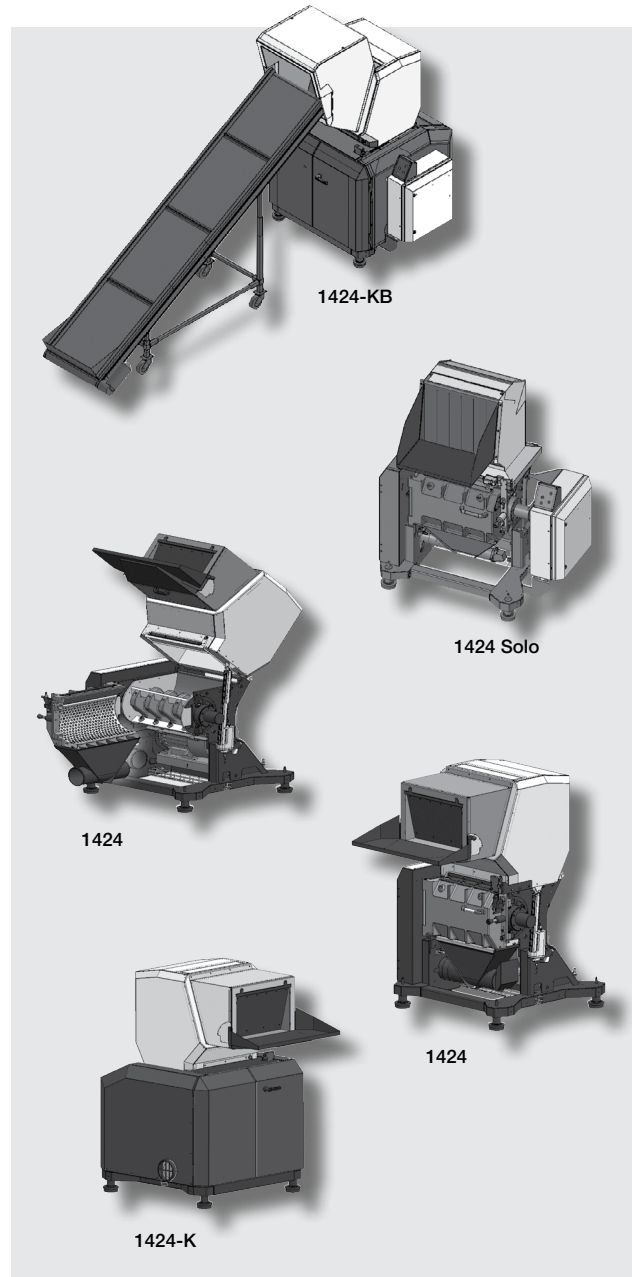

**Designations in the spare part catalog**

P	SE	DE	FR	ENGLISH	SPECIFICATION	Art No	Q	M	V
1	SKRUV	SCHRAUBE	VIS	SCREW	SHS MC6S 5X14	838151	5	1424	
					SHS MC6S 5X14 HARDENED	832257*	5	1424	
					SHS MC6S 6X20	834521	10	1436	
					SHS MC6S 6X20 HARDENED	834522	10	1436	
2	MUTTER	MUTTER	ÉCROU	NUT	9-40213	9	XX	-S	

P = Pos No

Art No = Article No

Q = Quantity

M = Model No

V = Variant

If anything has been specified in the M "Model No" column, the item only applies to that model No.

If anything has been specified in the V "Variant" column, the item only applies to that machinery variant.

### Feed tray, Funnel

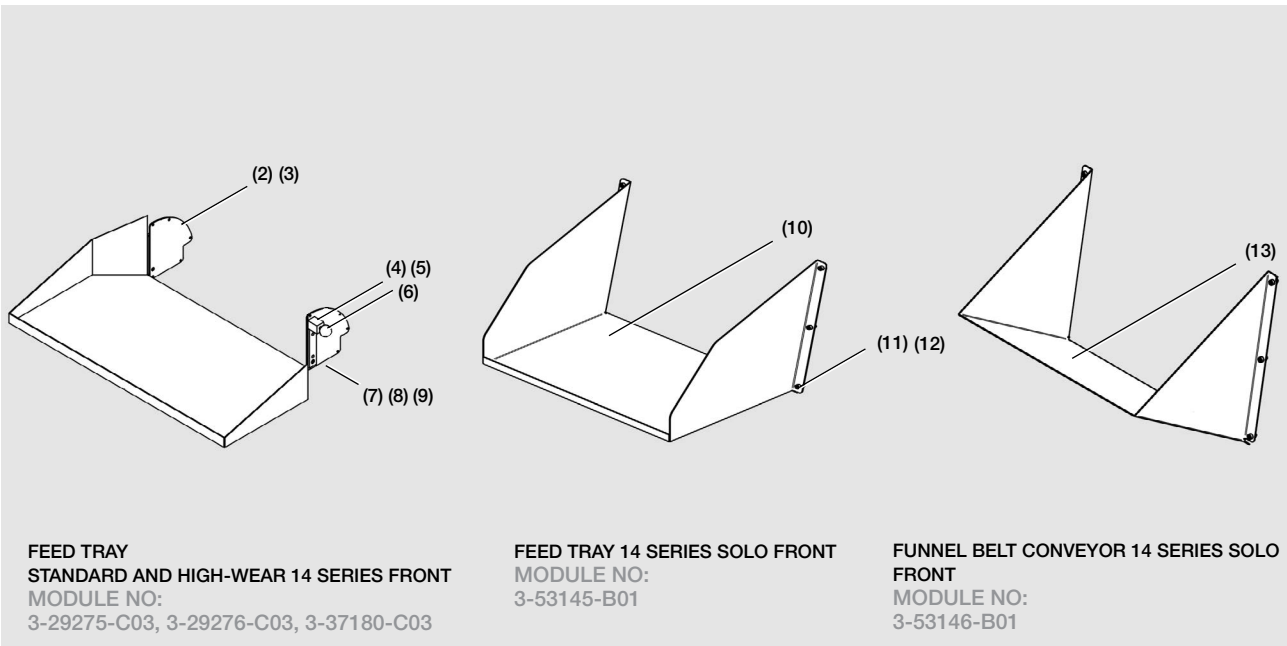

P	SE	FR	DE	ENGLISH	SPECIFICATIONS	ART NO	Q	M	V
1	INMATNINGSB	TABLE D'ALIM	AUFGABETISC	FEED TRAY	---	8118975	1	1418	STANDARD AND HIGH-WEAR PACKAGE
						8129144	1	1424	
						8137181	1	1436	
2	HÅLLARE	SUPORTE	HALTER	HOLDER	FEED TRAY	8327081	2	XX	
3	POP-NIT	RIVET	NIET	POP-RIVET	ALUMINIUM D 4,8	9-40261	12	XX	
4	LÅS	VERROU	SCHLOSS	LATCH	---	8411013	1	XX	
5	FJÄDER	RESSORT	FEDER	SPRING	FOR CATCH GK 205-X	9-50200	1	XX	
6	HANDTAGSKU	BILLE DE POI	KUGELKOPF	HANDLE BALL	WN05 30-M8	9-50278	1	XX	
7	SKRUV	VIS	SCHRAUBE	SCREW	SHS MC6S 8X25	9-40097	2	XX	
8	MUTTER	ECROU	MUTTER	NUT	BLIND RIVET M8 STEEL	9-50648	2	XX	
9	BUSSNING	DOUILLE	BÜCHSE	BUSHING	D=12/8X8,5	8442849	2	XX	
10	INMATNINGSB	TABLE D'ALIM	AUFGABETISC	FEED TRAY	---	8353598	1	1424	S
11	SKRUV	VIS	SCHRAUBE	SCREW	SHS MC6S 8X16	9-40032	6	1424	S, SB
12	MUTTER	ÉCROU	MUTTER	NUT	LOC-KING M 8	9-40317	6	1424	
13	TRATT	ENTONNOIR	TRICHTERAUF	FUNNEL	BAND CONV	8353599	1	1424	SB
(XX =1418, 1424, 1436)                      (S = SOLO)                      (SB = SOLO BAND CONVEYOR)									

**Inlet**

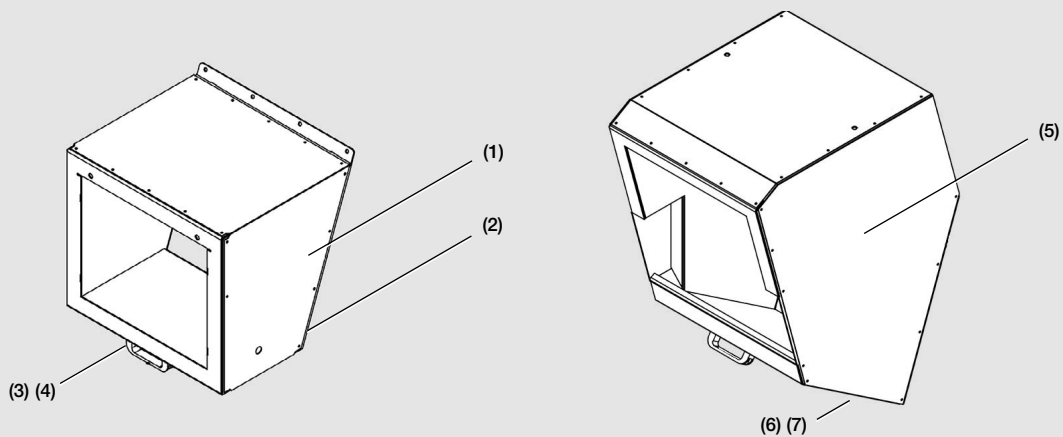

**INLET MANUAL FEED STANDARD AND HIGH-WEAR FRONT**  
 MODULE NO:  
 3-34786-C05, 3-34943-C05, 3-37049-C05

**INLET BELT CONVEYOR STANDARD AND HIGH-WEAR FRONT**  
 MODULE NO:  
 3-34787-C04, 3-34944-C03, 3-37058-C04

P	SE	FR	DE	ENGLISH	SPECIFICATIONS	ART NO	Q	M	V
1	INLOPP	ENTRÉE	EINLASS	INLET	455X350 ENC	8234261	1	1418	MF
					605X350 ENC	8234907	1	1424	
					905X350 ENC	8237050	1	1436	
2	LIST	BAGUETTE	LEISTE	LIST	KRONLIST 9 X 3 MM, BL	9-92455	1	XX	MF, BC
3	HANDTAG	POIGNÉE	GRIFF	HANDLE	CLAMP VN 130132-M8	9-91984	1	XX	
4	SKRUV	VIS	SCHRAUBE	SCREW	SHS MC6S 8X20	9-40070	6	1418	
							6	1424	
							7	1436	
5	INLOPP	ENTRÉE	EINLASS	INLET	BAND CONV	8234279	1	1418	BC
						8234922	1	1424	
						8237059	1	1436	
6	UNDERPLÅT	PLAQUE INFÉ	UNTERBLECH	BOTTOM PLATE	ENCLOSURE INLET	8334282	1	1418	
						8334923	1	1424	
						8337060	1	1436	
7	SKRUV	VIS	SCHRAUBE	SCREW	MONTAGE DRILWICKPH	9-40750	13	1418	
							?	1424	
							18	1436	
(XX = 1418, 1424, 1436)      (MF = MANUAL FEED)      (BC = BELT CONVEYOR)									

**Flap(s)**

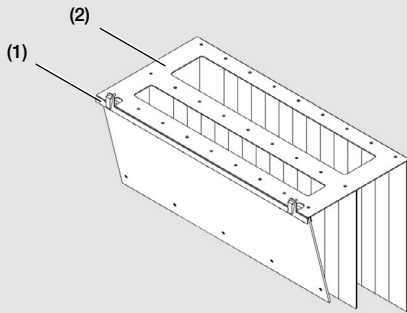

**FLAPS MANUAL FEED**  
 MODULE NO:  
 3-34788-C02, 3-34945-C02, 3-37068-C01

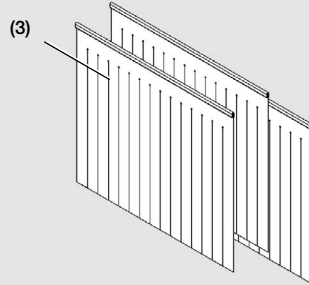

**FLAPS BELT CONVEYOR**  
 MODULE NO:  
 3-29210-C02, 2-29214-C02, 3-37077-C01

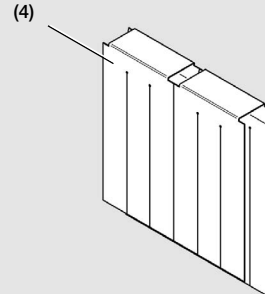

**FLAPS SOLO**  
 MODULE NO:  
 3-53147-B01

P	SE	FR	DE	ENGLISH	SPECIFICATION	ART NO	Q	M	V
1	LÅSHAKE	PÊNE DE VER	VERRIEGELU	LATCH	EXP. 19-91-10	9-50593	2	XX	MF
2	KLAFFPAKET	ENSEMB VOL	KLAPPENPAK	FLAP PARCEL	INLET 405X350	8234271	1	1418	
					INLET 605X350	8234915	1	1424	
					INLET 905X350	8237069	1	1436	
3	KLAFFAR	VOLET	KLAPPEN	FLAP	MIDDLE 454X740	8320895	1	1418	BC
					604X800 PUR STRIPED	8329254	1	1424	
					904X800 PUR STRIPED 6	8337078	1	1436	
4	KLAFFAR	VOLET	KLAPPEN	FLAPS	----	8353439	2	1424	S
(XX =1418, 1424, 1436, NA)      (MF = MANUAL FEED)      (BC = BELT CONVEYOR)      (S = SOLO)									

### Hopper

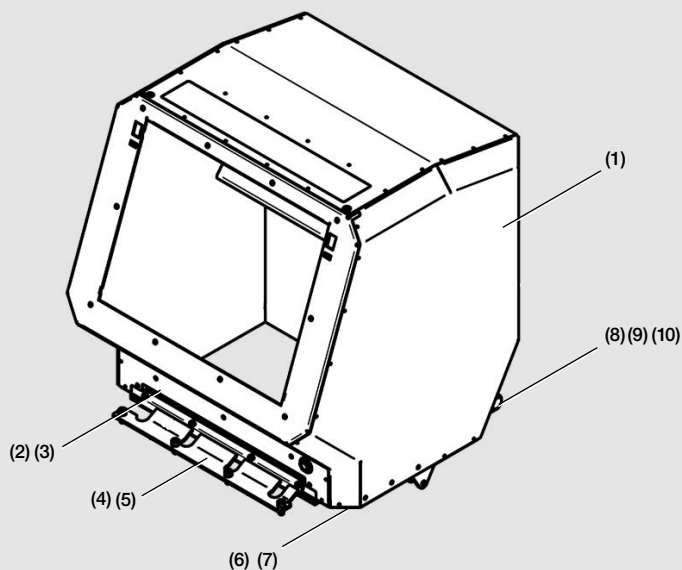

HOPPER FRONT  
STANDARD AND HIGH-WEAR  
MODULE NO:  
3-53136-C01, 3-53104-C02

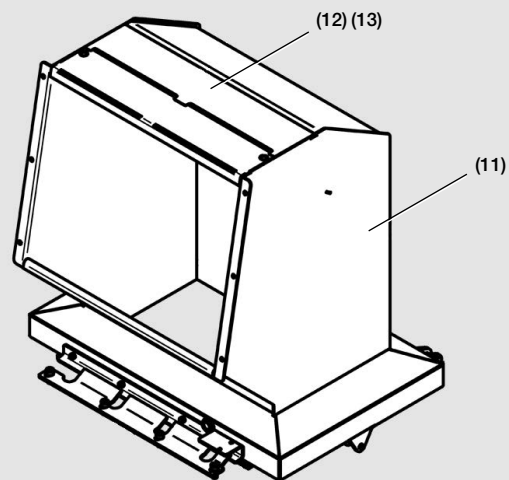

HOPPER FRONT SOLO  
MODULE NO:  
3-53144-C01

P	SE	FR	DE	ENGLISH	SPECIFICATION	ART NO	Q	M	V	
1	INMATNING	ALIMENTATIO	TRICHTER	HOPPER	---	(2-53560)	1	1418	F	
					FRONT 600X350	8253480	1	1424		
								1436		
2	LÅSLINJAL	RÈGLE	LINEAL	LOCKING RULER		(3-53571)	1	1418	F	
					KROSV	8353502	1	1424		
								1436		
3	SKRUV	VIS	SCHRAUBE	SCREW	SHS MC6S 8X25	9-40097	4	1418	F, S	
							8	1424		
								1436		
4	LÅSLINJAL	RÈGLE	LINEAL	LOCKING RULER	---	(3-53572)	1	1418	F, S	
					FRONT B. KROSV	8353505	1	1424		
								1436		
5	SKRUV	VIS	SCHRAUBE	SCREW	SHS MC6S 12X25	9-40051	4	XX		
6	TÅTNING	JOINT D'ÉTAN	DICHTUNG	SEALING	FRONT	8353476	1	1418	F, S	
							8353570			1424
										1436
7	SKRUV	VIS	SCHRAUBE	SCREW	TAPPING TAPTITE 5X12	9-41047	4	1424		
8	CYLINDBULT	BOULON CYL	ZYLINDERBOL	CLEVIS PIN	B20X60X5 ST ISO2341	9-40913	2	1424		
9	BRIC KA	RONDELLE	SCHEIBE	WASHER	BRB 21,0	9-40313	2	1424		
10	SAXPINNE	GOUPILLE F	STIFT	SPLIT PIN	SP 5,0 X 36 FZB	9-41044	2	1424		
11	INMATNING	ALIMENTATIO	TRICHTER	HOPPER	FRONT 600X350 SOLO	8153586	1	1424	S	
12	LUFT I NTAG	ENTRÉE D'AIR	LUFTEINLASS	AIR INLET	SOLO	8353596	1	1424		
13	SKRUV	VIS	SCHRAUBE	SCREW TAPPING	TAPTITE 6X12 PO	9-40915	6	1424		

(XX = 1418, 1424, 1436)

(F = HOPPER FRONT STANDARD & HIGH-WEAR PACKAGES)

(S = HOPPER FRONT SOLO)

### Hopper Device (optional)

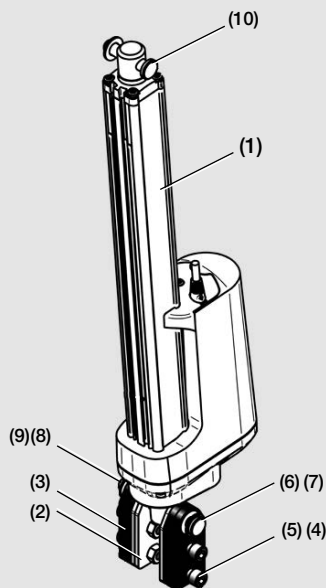

HOPPER DEVICE JACK (LINEAR ACTUATOR)  
MODULE NO:  
3-53114-C02

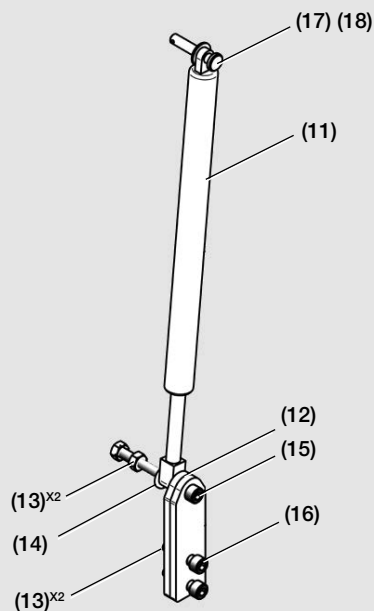

HOPPER DEVICE GAS SPRING  
MODULE NO: 3-53105-B02  
NOTE! A NEW DESIGN IS UNDER CONSTRUCTION!

P	SE	FR	DE	ENGLISH	SPECIFICATION	ART NO	Q	M	V
1	STÄLLDON	JACK ELECTR	HEBER ELEKT	LINEAR ACTUATOR	LA36 530+200	9-30308	1		
2	FÄSTE	FIXATION	BEFESTIGUNG	BRACKET	B=5 LINEAR ACTUATOR	8453427	3		
3	FÄSTE	FIXATION	BEFESTIGUNG	BRACKET	B=8 LINEAR ACTUATOR	8453428	4		
4	MUTTER	ÉCROU	MUTTER	NUT	M6M M 10 FZB	9-40030	4		
5	BRICKA	RONDELLE	WASHER	WASHER	BRB 13,0	9-40155	3		
6	SAX PINNE	GOUPILLE F	STIFT	SPLIT PIN	ISO1234 3,2X20ST FZB	9-40946	2		
7	CYLINDBULT	BOULON CYL	ZYLINDERBOL	CLEVIS PIN	B12X100X3,2 ISO2341	9-41040	1		
8	BUSSNING	DOUILLE	BÜCHSE	BUSHING	D=25/12-15 RUBBER	8453429	2		
9	SKRUV	VIS	SCHRAUBE	SCREW	SHS MC6S 10X40 DELTA	9-41015	4		
10	CYLINDBULT	BOULON CYL	ZYLINDERBOL	CLEVIS PIN	B12X55X3,2 ISO2341	9-41039	1		
11	GASFJÄDER	RESSORTGAZ	GASFEDER	GAS SPRING	2061LH 1700N	9-21036	1		
12	FÄSTE	FIXATION	BEFESTIGUNG	BRACKET	B=8 GAS SPRING KROS	4-053635	2		
13	MUTTER	ÉCROU	MUTTER	NUT	M6M M 10 FZB	9-40030	4		
14	BRICKA	RONDELLE	WASHER	WASHER	BRB 13,0	9-40155	2		
15	SKRUV	VIS	SCHRAUBE	SCREW	SHS MC6S 10X100	9-40235	1		
16	SKRUV	VIS	SCHRAUBE	SCREW	SHS MC6S 10X40 DELTA	9-41015	2		
17	CYLINDBULT	BOULON CYL	ZYLINDERBOL	CLEVIS PIN	B10X55X3,2 ISO2341	9-41057	1		
18	SAX PINNE	GOUPILLE F	STIFT	SPLIT PIN	ISO1234 3,2X20ST FZB	9-40946	1		

(XX = 1418, 1424, 1436)

### Safety Hopper & Cutter housing

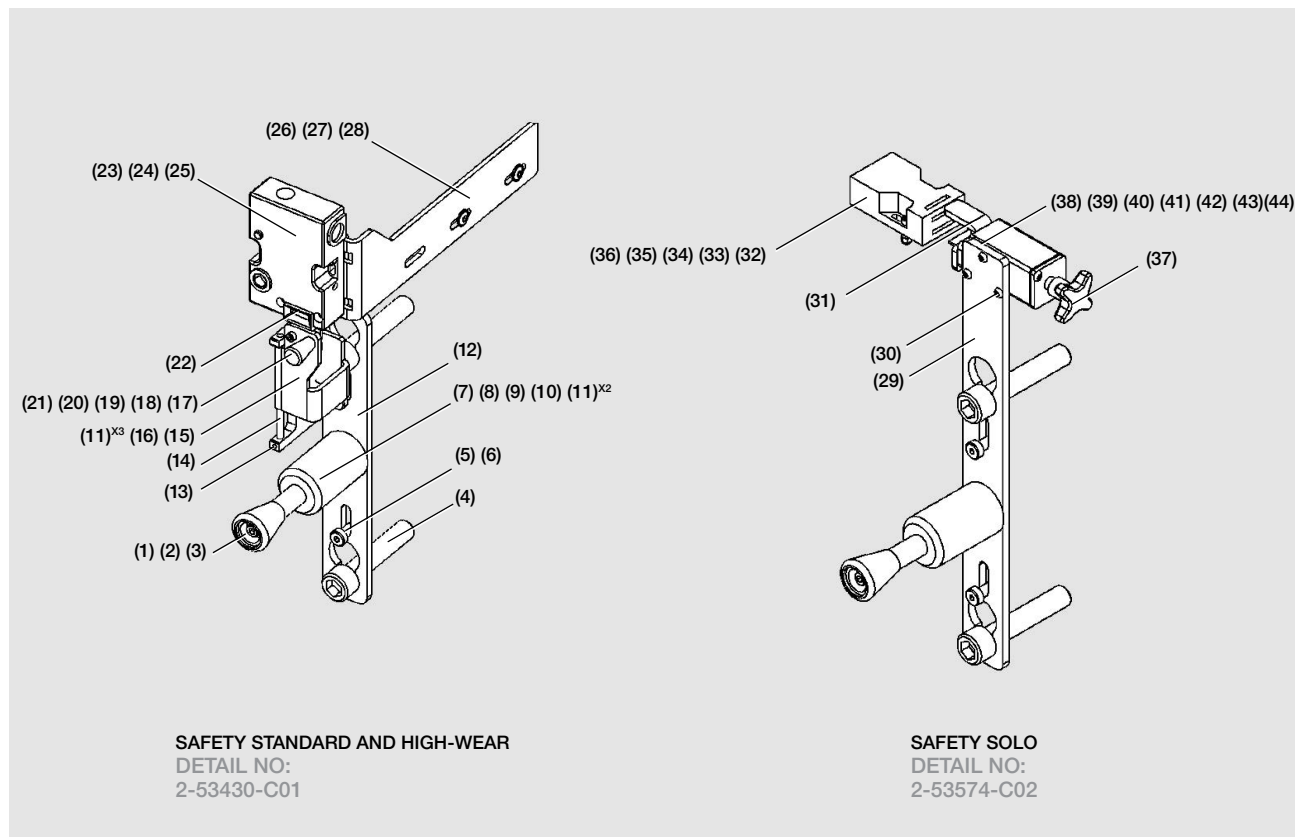

P	SE	FR	DE	ENGLISH	SPECIFICATION	ART NO	Q	M	V
1	KNOPP	POIGNÉE	KNOPF	KNOB	WN 41 40-8	9-50681	1	XX	STANDARD AND HIGH-WEAR, S
2	SKRUV	VIS	SCHRAUBE	SCREW	SHS MC6S 8X40	9-40200	1		
3	HANDTAG	POIGNÉE	GRIFF	HANDLE	KNOB	8445937	1		
4	SKRUV	VIS	SCHRAUBE	SCREW	SHS MC6S 20X100	9-40583	2		
5	PASSKRUV	BOULON	PASSBOLZEN	FITTING BOLT	M 8 X 10 X 16MM	9-50745	2		
6	BRICKA	RONDELLE	SCHEIBE	WASHER	SPRING 23X10,2X0,9	9-40961	12		
7	HÅLLARE	SUPPORT	HALTER	HOLDER	SPRING HANDLE	8453401	1		
8	TRYCKFJÄDER	RESSORT PRE	DRUCKFEDER	COMPRESSION SPRIN	DY=24,77 DT=2,16 LO	9-50697	1		
9	BRICKA	RONDELLE	SCHEIBE	WASHER	1X32X4 DIN 1441 FZB	9-40960	1		
10	LÅS	VERROU COM	SCHLOSS	LOCK	WASHERS FOR SHAFT	9-40944	1		
11	SKRUV	VIS VIS D'ARR	SCHRAUBE	SCREW	SHS MF6S 5X18	9-40611	5	XX	STANDARD & HIGH-WEAR
							2	XX	S
12	LÅSBLECK	LAME VERRO	SCHLOSSBLE	LOCKING CLIP	---	8353400	1	XX	STANDARD AND HIGH-WEAR
13	STOPPSKRUV	VIS D'ARRÊT	ANSCHLSCHR	GRUB SCREW	SK6SS 5X6	9-40563	1		
14	AXEL	ARBRE	ACHSE	SHAFT	---	8453534	1		
15	SKYDD	PROTECTION	SCHUTZ	PROTECTION	LOCKING CLIP	8353531	1		
16	GÅNGJÄRN	CHARNIÈRE	SCHARNIER	HINGE	LOCKING CLIP	8353530	1		
17	KNOPP	POIGNÉE	KNOPF	KNOB	LN93 20-M5	9-50746	1		
18	SKRUV	VIS	SCHRAUBE	SCREW	SHS MC6S 5X16	9-40115	2		
19	SKRUV	VIS	SCHRAUBE	SCREW	SHS MF6S 5X18	9-40611	3		
20	BRICKA	RONDELLE	SCHEIBE	WASHER	BRB 5,3 FZB	9-40243	2		
21	MUTTER	ÉCROU	MUTTER	NUT	LOC-KING M 5	9-40267	1		

(XX = 1418, 1424, 1436)

(S = SOLO)

(Continued)

Safety Hopper & Cutter housing (continued from previous)

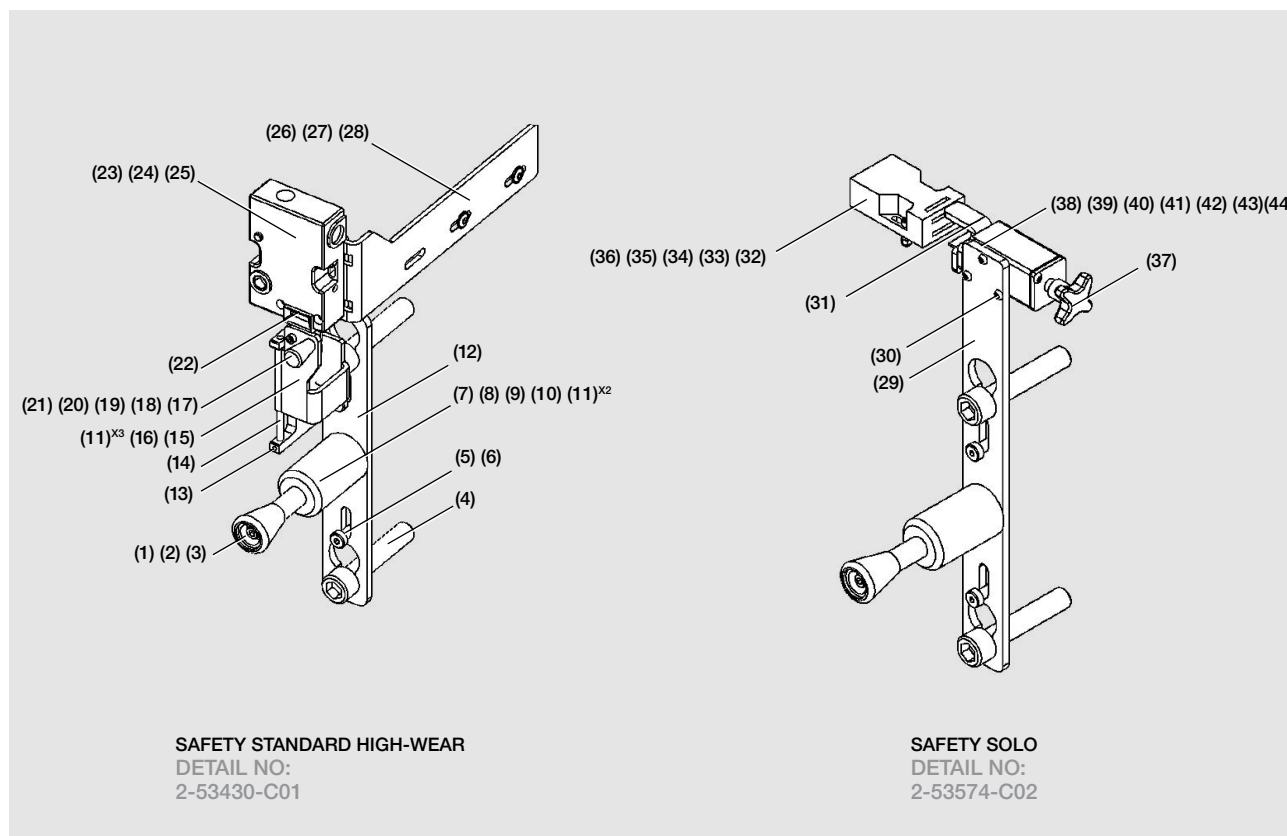

SAFETY STANDARD HIGH-WEAR  
DETAIL NO:  
2-53430-C01

SAFETY SOLO  
DETAIL NO:  
2-53574-C02

P	SE	FR	DE	ENGLISH	SPECIFICATION	ART NO	Q	M	V	
22	NYCKEL	CLÉ	SCHLÜSSEL	KEY	LAT GUARD MASTER	9-11649	1	XX	STANDARD AND HIGH-WEAR	
23	BRYTARE NYC	INTERUPTEUR	SCHALTER	SWITCH	TUMBLER LOCK TLS1-	9-93207	1			
24	SKRUV	VIS	SCHRAUBE	SCREW	SHS MC6S 5X22	9-40217	2			
25	SKRUV	VIS	SCHRAUBE	SCREW	SHS MC6S 5X35	9-40174	2			
26	HÅLLARE	SUPPORT	HALTER	HOLDER	SWITCH	8353503	1			
27	SKRUV	VIS	SCHRAUBE	SCREW	SHS K6SF 8X16 10.9	9-40885	2			
28	BRICKA	RONDELLE	SCHEIBE	WASHER	KROSV	8453504	1	XX	S	
29	LÅSBLECK	LAME VERRO	SCHLOSSBLE	LOCKING CLIP	---	8353575	1			
30	SKRUV	VIS	SCHRAUBE	SCREW	HS K6S 5X16	9-40796	3			
31	NYCKEL	CLÉ	SCHLÜSSEL	KEY	OPERATOR CLAMP SC	9-11003	1			
32	BRYTARE	INTERUPTEUR	SCHALTER	SWITCH	AZ16-02 ZVRK	9-11002	1			
33	BRICKA	RONDELLE	SCHEIBE	WASHER	BRB 5,3 FZB	9-40243	4			
34	MUTTER	ÉCROU	MUTTER	NUT	LOC-KING M 5	9-40267	2			
35	SKRUV	VIS	SCHRAUBE	SCREW	SHS K6S 5X12	9-41050	2			
36	SKRUV	VIS	SCHRAUBE	SCREW	SHS MC6S 5X22	9-40217	2			
37	STJÄRNVED	POIGNÉE ÉTOI	STERNGRIFF	STAR KNOB	GN6335.1 E50-M10	9-50393	1			
38	FÄSTE	FIXATION	BEFESTIGUNG	BRACKET	BREAKING SCREW	8353578	1			
39	LOCK	COUVERCLE	DECKEL	COVER	---	8453584	1			
40	SKRUV	VIS	SCHRAUBE	SCREW	---	8353582	1			
41	STOPPSKRUV	VIS ARRET	ANSCHLSHRA	GRUBSCREW	P6SS 6X12	9-40607	1			
42	BRICKA	RONDELLE	SCHEIBE	WASHER	---	8453583	1			
43	CYLINDER	CYLINDER	ZYLINDER	CYLINDER	KEY	8353775	1			
44	BRICKA	RONDELLE	SCHEIBE	LOCK WASHERS	FOR SHAFT DIA=8MM	9-41058	1			
					(XX = 1418, 1424, 1436)	(S = SOLO)				

**Cutter housing**

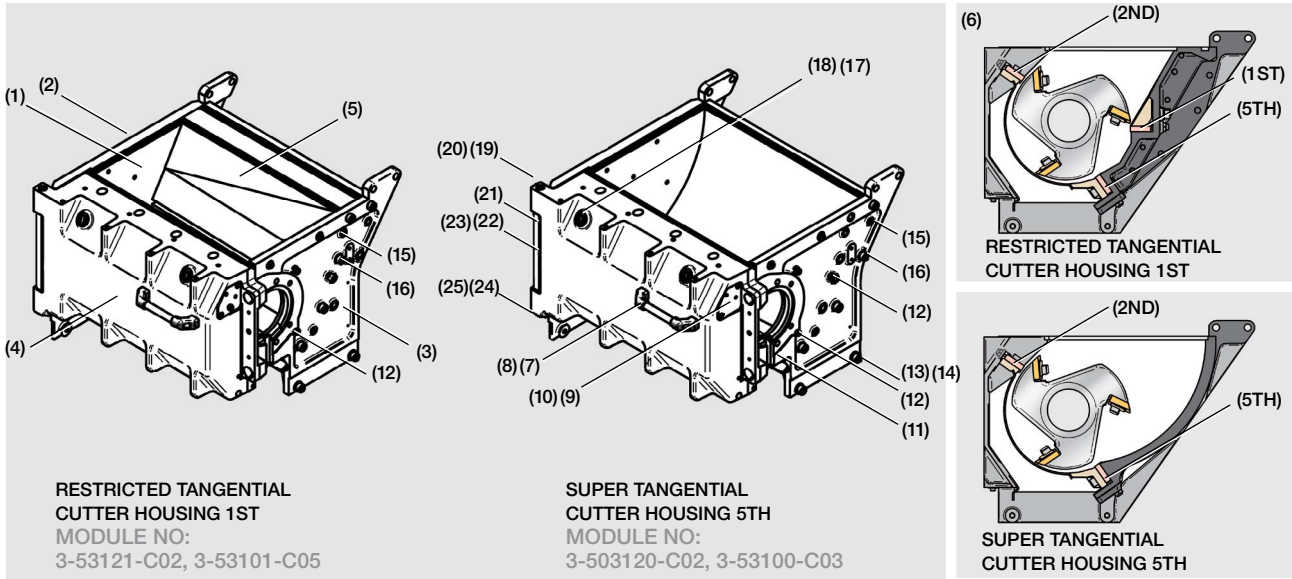

P	SE	FR	DE	ENGLISH	SPECIFICATION	ART NO	Q	M	V
1	SIDA INRE	CÔTÉ INTÉRI	SEITE INNERE	SIDE INNER	1ST, RESTRICTED TANGENTIAL	8253309	2	XX	1ST CU
					1ST HA, RESTRICTED TANGENTIAL	8453688	2	XX	1ST CU H
					5TH, SUPER TANGENTIAL	8253308	2	XX	5TH CU
					5TH HA, SUPER TANGENTIAL	8453689	2	XX	5TH CU H
2	SIDA V	CÔTÉ G	SEITE L	SIDE L	BLACK	8153352	1	XX	
3	SIDA H	CÔTÉ D	SEITE R	SIDE R	BLACK	8153353	1	XX	
4	FRONTSIDA	CÔTÉ AVANT	VORDERSEITE	FRONTSIDE	BLACK	8153326	1	1418	
						8153302	1	1424	
5	BAKSIDA	CÔTÉ ARRIÈ	RÜCKSEITE	BACK SIDE	1ST, BLACK RESTRICTED TANGENTIAL	8153325	1	1418	1ST CU
						8153301	1	1424	
					1ST HA, BLACK RESTRICTED TANGENTIAL	8453760	1	1418	1ST CU H
						8453762	1	1424	
					5TH, BLACK SUPER TANGENTIAL	8153324	1	1418	5TH CU
						8153300		1424	
					5TH HA, BLACK SUPER TANGENTIAL	8453761	1	1418	5TH CU H
						8453763	1	1424	
6	STÖDLINJAL	RÈGLE D'APP	KLEMMLEISTE	SUPPORT RULE	1ST RESTRICTED TANGENTIAL	8253333	1	1418	1ST
						8253338	1	1424	
					2ND	8353334	1	1418	2ND
						8253387	1	1424	
					5TH SUPER TANGENTIAL	8253335	1	1418	5TH
						8253323	1	1424	
7	HANDTAG	POIGNÉE	GRIFF	HANDLE	CLAMP WN428 20-200	9-50751	1	XX	
8	SKRUV	VIS	SCHRAUBE	SCREW	SHS MC6S 8X20	9-40070	2	XX	
9	TÄCKPLÅT	PLAQUE RECO	ABDECKPLAT	COVER PLATE	RIGHT	8353314	1	XX	
					LEFT	8353315	1	XX	
10	SKRUV	VIS	SCHRAUBE	SCREW	SHS MF6S 8X20 10.9	9-41041	4	XX	
11	SKRUV	VIS	SCHRAUBE	SCREW	SHS MF6S 10X20	9-40116	2	XX	
12	SKRUV	VIS	SCHRAUBE	SCREW	SHS M10X32 MC6S	8453629	10	XX	1ST CU
							12	XX	5TH CU

(1ST CU = CUTTER HOUSING 1ST )  
(1ST CU H = CUTTER HOUSING 1ST HARDENED)  
(XX = 1418, 1424, 1436)

(5TH CU = CUTTER HOUSING 5TH)  
(5TH CU H = CUTTER HOUSING 5TH HARDENED)

(1ST = KNIFE POSITION 1ST)  
(2ND = KNIFE POSITION 2ND)  
(5TH = KNIFE POSITION 5TH)

(Continued)

Cutter housing (continued from previous)

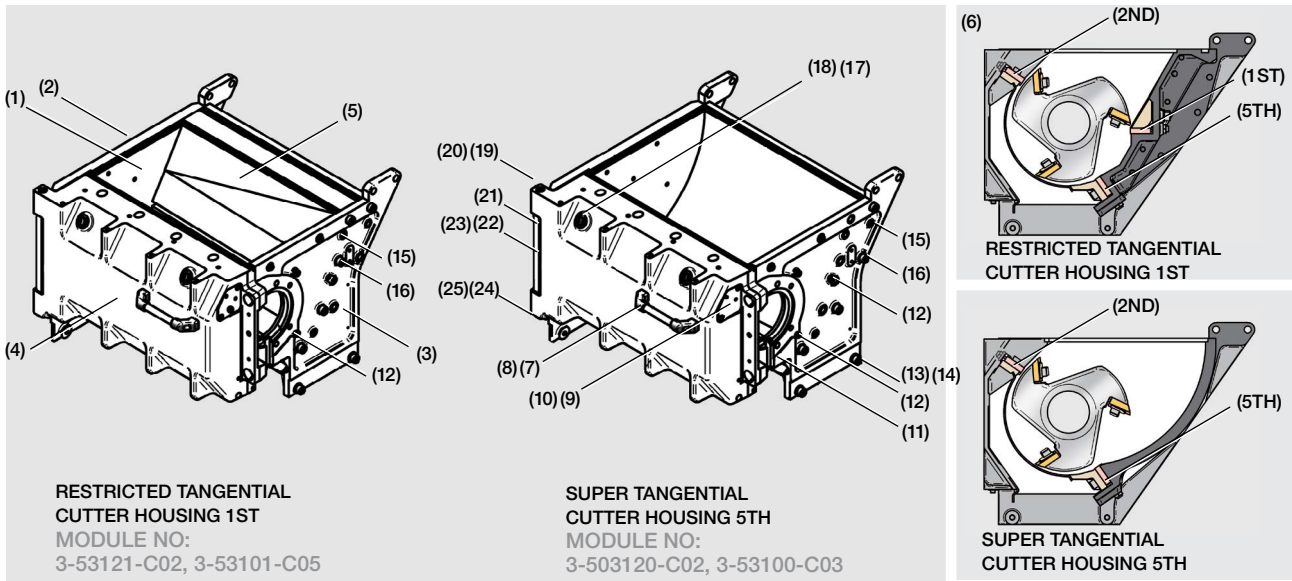

P	SE	FR	DE	ENGLISH	SPECIFICATION	ART NO	Q	M	V	
13	BRICKA	RONDELLE	SCHEIBE	WASHER	BRB 17,0	9-40035	4	XX		
14	SKRUV	VIS	SCHRAUBE	SCREW	SHS MC6S 16X30 UNBR	9-40436	4	XX		
15	CYLINDR PIN	GOUPILLE CY	ZYLIND STIFT	PARALLELL PIN	INSIDE THREADED	9-50748	6	XX	1ST CU	
							4	XX	5TH CU	
16	SKRUV	VIS	SCHRAUBE	SCREW	SHS MC6S 16X40 12.9	9-41002	10	XX	1ST CU	
							8	XX	5TH CU	
17	SKRUV	VIS	SCHRAUBE	GRUBSCREW	T6SS 16X40	8453322	6	XX	1ST CU	
							4	XX	5TH CU	
18	MUTTER	ÉCROU	MUTTER	NUT	LOW ML6M M 16	9-40373	6	XX	1ST CU	
							4	XX	5TH CU	
19	GLIDLAGER	PALIER LISSE	GLEITLAGER	SLIDE BEARING	.PCM 202320 M	9-90583	6	XX		
20	AXEL	ARBRE	ACHSE	SHAFT	HINGE FRONT SIDE	8453313	2	XX		
21	GÅNGJÄRN	CHARNIÈRE	SCHARNIER	HINGE	FRONT SIDE BLACK	8353307	1	XX		
22	CYLINDR PIN	GOUPILLE CY	ZYLIND STIFT	PARALLELL PIN	10X45 HARDENED	9-50747	2	XX		
23	SKRUV	VIS	SCHRAUBE	SCREW	SHS MC6S 16X45	9-40674	2	XX		
24	BRICKA	RONDELLE	SCHEIBE	WASHER	BRB 8,4 DIN-9021 Y	9-40592	1	XX		
25	SKRUV	VIS	SCHRAUBE	SCREW	SHS MC6S 8X10	9-40225	1	XX		
(1ST CU = CUTTER HOUSING 1ST)				(5TH CU = CUTTER HOUSING 5TH)				(1ST = KNIFE POSITION 1ST)		
(1ST CU H = CUTTER HOUSING 1ST HARDENED)				(5TH CU H = CUTTER HOUSING 5TH HARDENED)				(2ND = KNIFE POSITION 2ND)		
(XX = 1418, 1424, 1436)								(5TH = KNIFE POSITION 5TH)		

**Rotor**

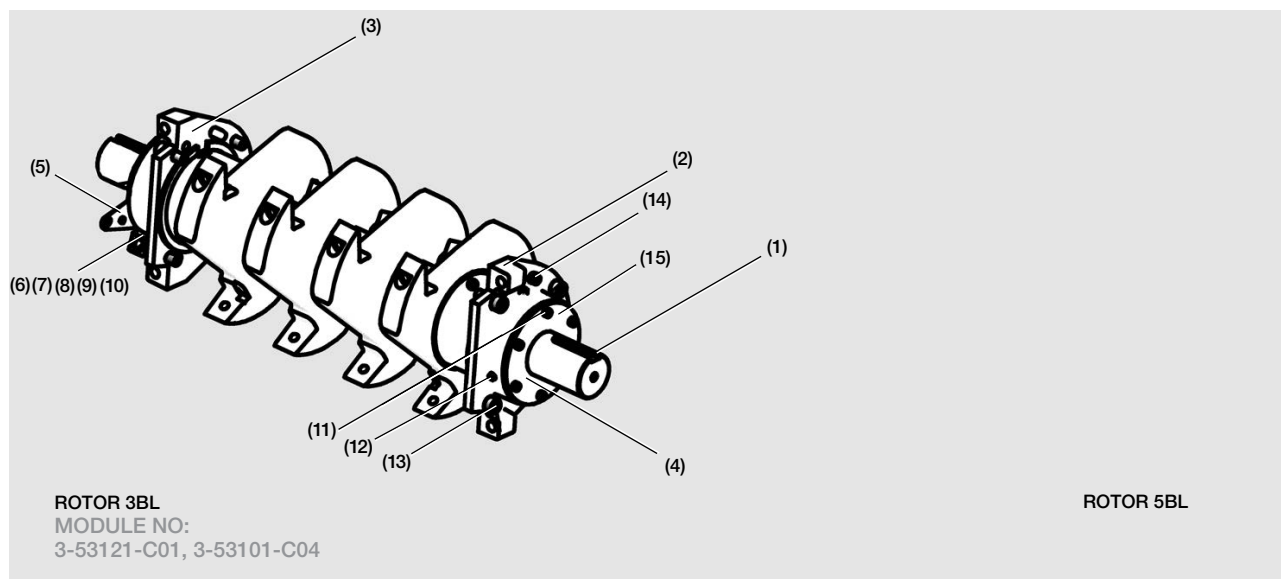

**ROTOR 3BL**  
MODULE NO:  
3-53121-C01, 3-53101-C04

**ROTOR 5BL**

P	SE	FR	DE	ENGLISH	SPECIFICATION	ART NO	Q	X	V
1	KUTTER	ROTOR	ROTOR	ROTOR	3BL CAST	8153342	1	1418	3BL
						8153340	1	1424	
2	LAGERHUS	BOÎTIER PALI	LAGER GEHÄU	BEARING HOUSING	H	8153354	1	XX	
3	LAGERHUS	BOÎTIER PALI	LAGER GEHÄU	BEARING HOUSING	V	8153359	1	XX	
4	LAGERLOCK	CHAPEAU PAL	LAGERDECKE	BEARING COVER	--- (H)	8353357	1	XX	
5	LAGERLOCK	CHAPEAU PAL	LAGERDECKE	BEARING COVER	V	8353358	1	XX	
6	LAGER	PALIER	LAGER	BEARING	BS2-2215-2CS	9-93773	2	XX	
7	TÄTNINGSRI	BAGUE ÉTANC	DICHT RING	SEALING RING	CR 90X140X12	9-60233	2	XX	
8	RING	BAGUE	RING	RING	D=130/121X5 GUIDE	8453356	1	XX	
9	LABYRINTRI	BAUGE	LABYRINTRIN	LABYRINTH RING	---	8353355	2	XX	
10	STOPPSKRUV	VIS D'ARRÊT	ANSCHLSCHR	GRUB SCREW	T6SS 8X30	9-41038	3	XX	
11	SKRUV	VIS	SCHRAUBE	SCREW	SHS MC6S 8X16	9-40032	12	XX	
12	SKRUV	VIS	SCHRAUBE	SCREW	SHS MC6S 6X6	9-40722	2	XX	
13	SKRUV	VIS	SCHRAUBE	SCREW	SHS MC6S 16X40 12.9	9-41002	8	XX	
14	CYLINDR PIN	GOUPILLE CY	ZYLIND STIFT	PARALLELL PIN	INSIDE THREADED	9-50748	4	XX	
15	SKRUV	VIS	SCHRAUBE	SCREW	SHS MC6S 6X60	9-40450	6	XX	
(XX = 1418, 1424, 1436)      (3BL = 3-BLADE ROTOR)      (5BL = 5-BLADE ROTOR)									

**Knives**

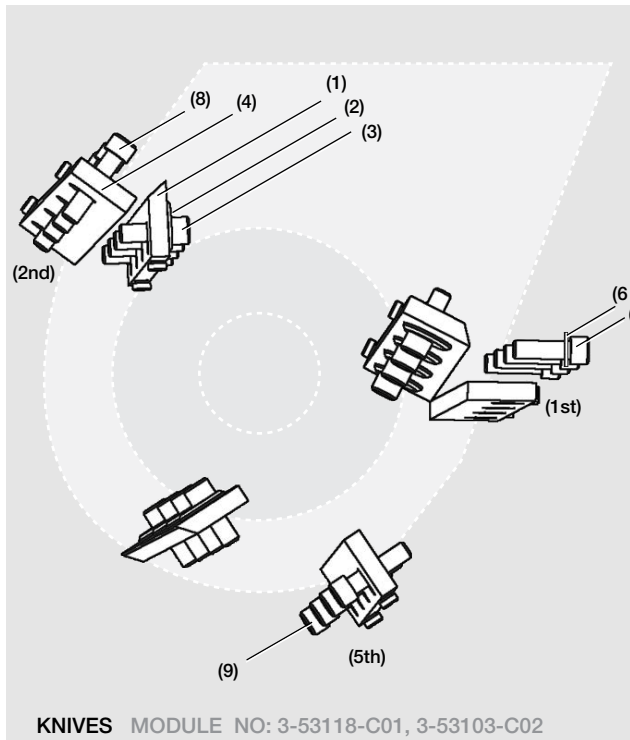

KNIVES MODULE NO: 3-53118-C01, 3-53103-C02

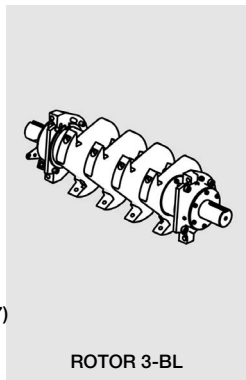

ROTOR 3-BL

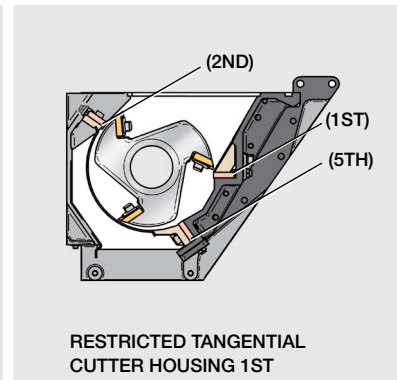

RESTRICTED TANGENTIAL CUTTER HOUSING 1ST

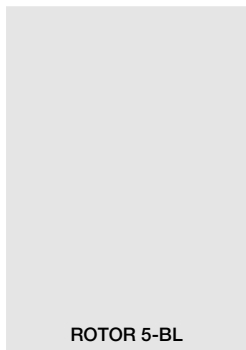

ROTOR 5-BL

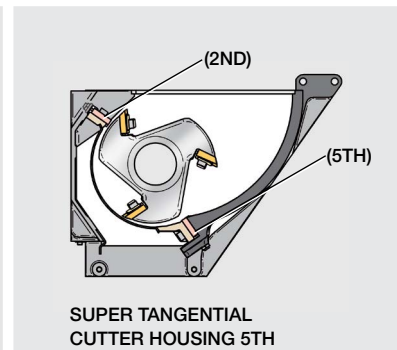

SUPER TANGENTIAL CUTTER HOUSING 5TH

P	SE	FR	DE	ENGLISH	SPECIFICATION	ART NO	Q	X	V
1	KNIV ROT	COUTEAUX ROT	ROTORMESSE	KNIFE ROT	---	8353364	3	1418	3BL
						8353360	3	1424	
2	BRICKA	RONDELLE	SCHEIBE	WASHER	KNIFE ROTATING	8411835	9	1418	
							12	1424	
3	SKRUV	VIS	SCHRAUBE	SCREW	SHS MC6S 16X45 UNBR	9-41046	9	1418	
							12	1424	
4	KNIV FAST	COUTEAUX FIX	STATORMESS	KNIFE FIXED	---	8353366	1***	1418	
							8353362	1***	1424
5*	DISTANS	ENTRETOISE	ABSTANDSTÜ	DISTANCE	SUPPORT RULE	8353696	1	1418	DU
							8353697	1	
4	KNIV FAST	COUTEAUX FIX	STATORMESS	KNIFE FIXED	---	8353366	1***	1418	
							8353362	1***	1424
5*	DISTANS	ENTRETOISE	ABSTANDSTÜ	DISTANCE	SUPPORT RULE	8353696	1	1418	DU
							8353697	1	
(XX = 1418, 1424, 1436) (5* = DISTANCE "KNIFE DUMMY" IS NOT SHOWN IN FIGURE) (1*** = ONE KNIFE PER KNIFE POSITION) (10** = SUPPORT RULE IS NOT SHOWN IN FIGURE)						(3BL = 3-BLADE ROTOR) (5BL = 5-BLADE ROTOR)		(1ST = KNIFE POSITION 1ST) (2ND = KNIFE POSITION 2ND) (5TH = KNIFE POSITION 5TH) (DU = KNIFE DUMMY FITS ALL KNIFE POS)	

(Continued)

Knives (continued from previous)

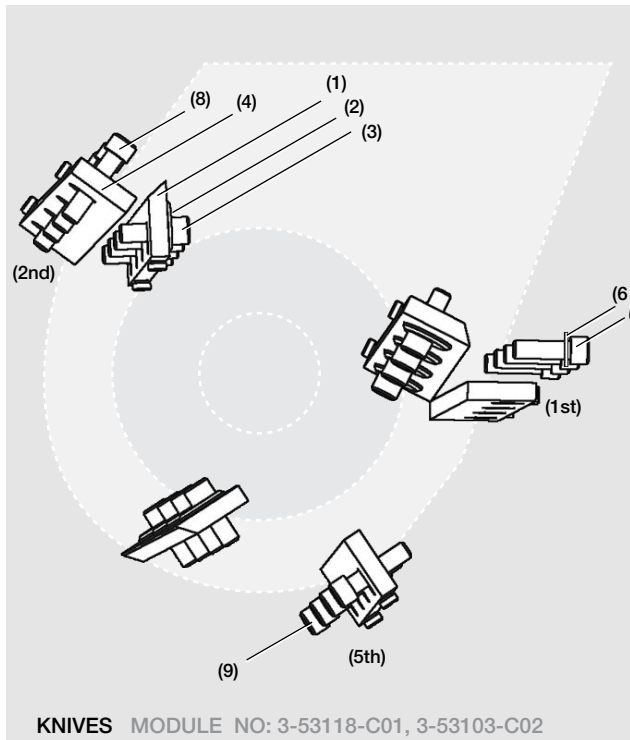

KNIVES MODULE NO: 3-53118-C01, 3-53103-C02

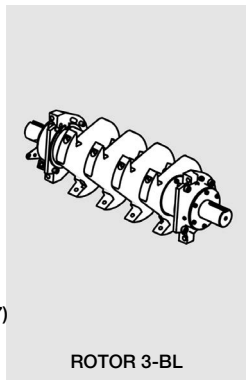

ROTOR 3-BL

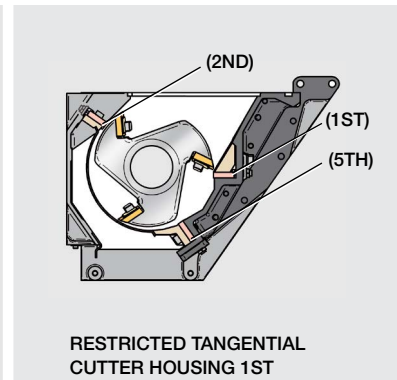

RESTRICTED TANGENTIAL CUTTER HOUSING 1ST

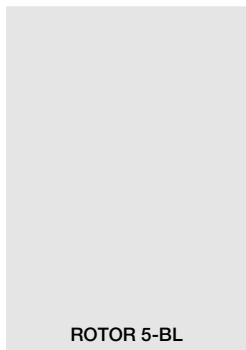

ROTOR 5-BL

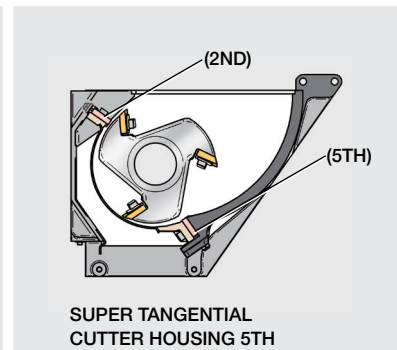

SUPER TANGENTIAL CUTTER HOUSING 5TH

P	SE	FR	DE	ENGLISH	SPECIFICATION	ART NO	Q	X	V
6	BRICKA	RONDELLE	SCHEIBE	WASHER	HARDENED M16 FZV 691	9-40784	3	1418	1ST
							4	1424	
8	SKRUV	VIS	SCHRAUBE	SCREW	SHS MC6S 16X70 12.9 U	9-40405	3	1418	1ST
							4	1424	
7	SKRUV	VIS	SCHRAUBE	SCREW	SHS MC6S 16X50 UNBR	9-40074	3	1418	2ND
							4	1424	
9	SKRUV	VIS	SCHRAUBE	SCREW	SHS MC6S 16X60 UNBR	9-40074	3	1418	5TH
							4	1424	
10**	STÖDLINJAL	RÈGLE D'APP	KLEMMLEISTE	SUPPORT RULE	1ST	8253333	1	1418	1ST
							1	1424	
					2ND	8353334	1	1418	2ND
							1	1424	
					5TH	8253335	1	1418	5TH
							1	1424	

(XX = 1418, 1424, 1436) (3BL = 3-BLADE ROTOR (1ST = KNIFE POSITION 1ST)  
 (5\* = DISTANCE "KNIFE DUMMY" IS NOT SHOWN IN FIGURE) (5BL = 5-BLADE ROTOR) (2ND = KNIFE POSITION 2ND)  
 (1\*\*\* = ONE KNIFE PER KNIFE POSITION) (5TH = KNIFE POSITION 5TH)  
 (10\*\* = SUPPORT RULE IS NOT SHOWN IN FIGURE) (DU = KNIFE DUMMY FITS ALL KNIFE POS)

**Screen box, Screen**

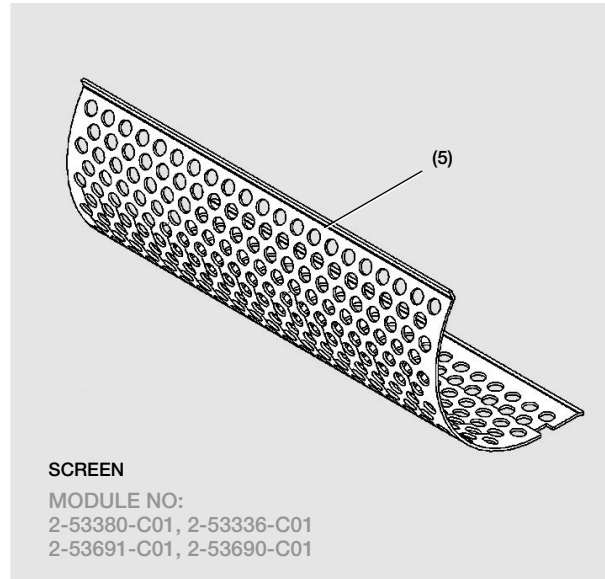
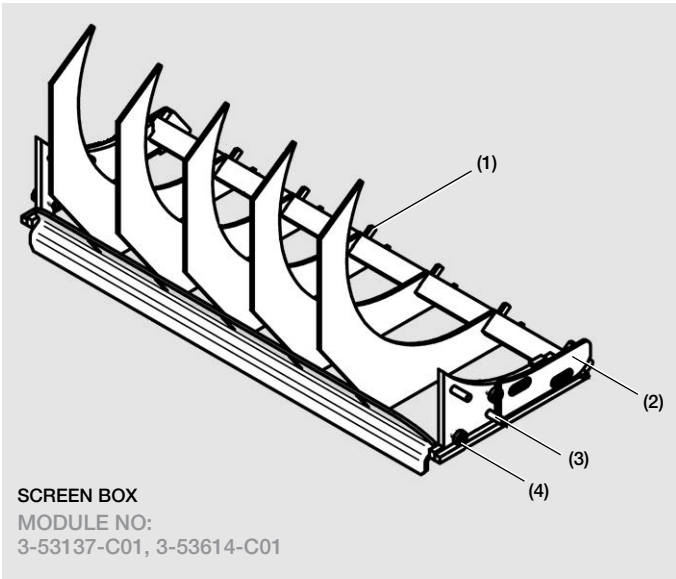

P	SE	FR	DE	ENGLISH	SPECIFICATION	ART NO	Q	M	V
1	GALLERLÅDA	BOÎTE DE TAM	SIEBKASTEN	SCREEN BOX	---	8153646	1	1418	
						8153615	1	1424	
2	GALLERBÅGE	COURBE DE T	SIEBBOGEN	SCREEN BOW	OUTER L	8353602	1	XX	
						OUTER R	8353603	1	
3	SPÄNNSTIFT	GOUPILLE SE	SPANNSTIFT	SPRING PIN	FRP 8 X 20	9-50494	2	XX	
						FRP 8 X 32	9-50079	2	
4	SKRUV	VIS	SCHRAUBE	SCREW	SHS MC6S 10X20	9-40037	4	XX	
5	GALLER	GRILLE	SIEB	SCREEN		8253380-YY	1	1418	H
						8253336-YY	1	1424	
						8253691-YY*	1	1418	
						8253690-YY*	1	1424	

(XX = 1412, 1418, 1424) (H = HARDENED)

(YY = SCREEN HOLE DIAMETER IN MM + TYPE OF SCREEN)

(YY\* = HARDENED SCREEN, ADD "N" AFTER THE THE HOLE DIAMETER)

EXAMPLE: 8253380-08 = STANDARD SCREEN FOR 1418 WITH 8 MM HOLES  
EXAMPLE: 8253380-08TD11= OPEN AREA SCREEN FOR 1418 WITH 8 MM HOLES

EXAMPLE: 8253691-08N = HARDENED SCREEN FOR 1418 WITH 8 MM HOLES

-YY STANDARD SCREEN		
Diameter	TD	OPEN %
04	6	40
05	8	35
06	9	40
08	12	40
10	15	40
12	17	45
17	26	39
25	39	38

-YY OPEN AREA SCREEN		
Diameter	TD	OPEN %
04	5.5	48
05	7	45
06	8	50
08	11	48
10	14	46
12	16	51
17	24	45
25	36	44

### Granule bin, Discharge

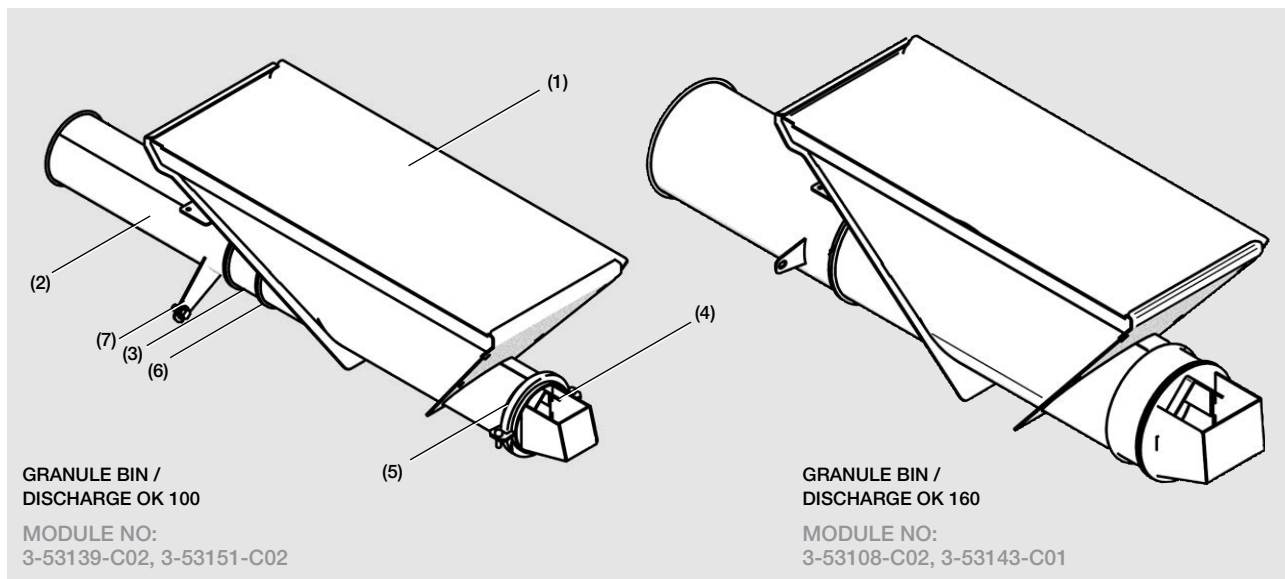

P	SE	FR	DE	ENGLISH	SPECIFICATION	ART NO	Q	M	V
1	GRANULATLÅD	BAC À GRANU	MAHLGUTKAS	GRANULE BIN	OK100	8153648	1	1418	OK100
						8153631	1	1424	
					OK160	8153680	1	1418	OK160
						8153443	1	1424	
2	STOS UTLOPP	RACC SORTIE	STUTZEN, AUS	FLANGE OUTLET	OK100	8353458	1	XX	OK100, D
					OK100 L = 360	8353642	1	XX	OK100, F
					OK160	8353449	1	XX	OK160
3	RÖR	TUYAU	ROHR	PIPE	OK100X60, BLACK	8453456	1	XX	OK100
					OK160X60	9-20098	1	XX	OK160
4	LUFTINTAG	ENTRÉE D'AIR	LUFTEINLASS	AIR INLET	OK 100, BLACK	8353470	1	1418	OK100
						8353625	1	1424	
					OK160, BLACK	8353685	1	1418	OK160
						8353621	1	1424	
5	BULTKOPPL	BOULON ASS	BOLZEN KUPP	BOLT COUPLING	OK100	9-20729	1	XX	OK100
					OK160	9-20203	1	XX	OK160
6	SNABBKOPPL	RACCORD RA	SCHNELLKUP	QUICK COUPLING	OK100	9-20415	2	XX	OK100
					OK160	9-20107	2	XX	OK160
7	SKRUV	VIS	SCHRAUBE	SCREW	TAPPING TAPTITE 8X16	9-40444	1	XX	OK100

(XX = 1418, 1424, 1436)      (OK100 = DISCHARGE WITH OUTLET PIPE Ø 100MM)      (OK160 = DISCHARGE WITH OUTLET PIPE Ø 160MM)  
(D = BLOWER DETACHED)      (F = BLOWER FIXED)

**Transmission, Motor, Flywheel**

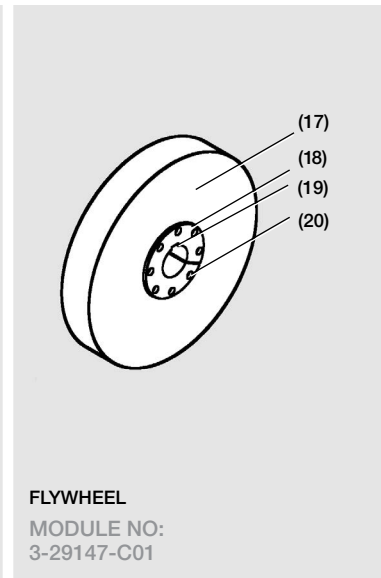
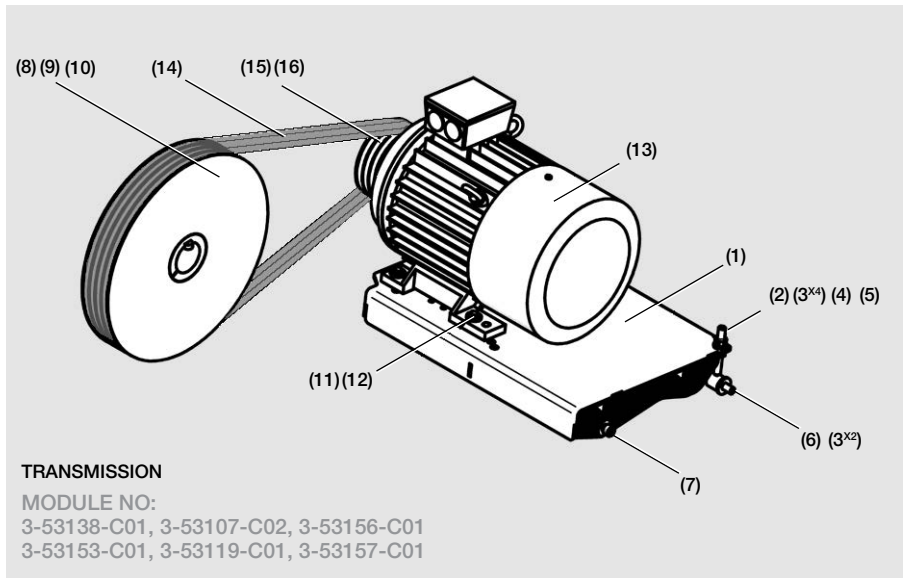

P	SE	FR	DE	ENGLISH	SPECIFICATION	ART NO	Q	M	V																																																						
1	MOTORBRYG	SUPPORT MO	MOTORBEFES	MOTOR MOUNTING	BRACKET BLACK	8253677	1	1418																																																							
						8253418	1	1424																																																							
						8153693	1	1436																																																							
2	REMSTRÄCK	TENDEUR CO	KEILRIEMSPA	BELT STRETCHER	L=140 BLACK	8353426	2	XX																																																							
3	BRICKA	RONDELLE	SCHEIBE	WASHER	BRB 17,0	9-40035	6	XX																																																							
4	MUTTER	ÉCROU	MUTTER	NUT	M6M M 16	9-40034	2	XX																																																							
5	MUTTER	ÉCROU	MUTTER	NUT	LOC-KING M 16	9-40078	2	XX																																																							
6	SKRUV	VIS	SCHRAUBE	SCREW	HHS M6S 16X70	9-40254	2	XX																																																							
7	SKRUV	VIS	SCHRAUBE	SCREW	SHS MC6S 16X40 12.9	9-41002	2	XX																																																							
8	REMSKIVA	POULIE	RIEMENSCHEI	PULLEY	ROTOR 4 SPB 507	8207023	1	XX																																																							
9	KLÄMBUSSN	COUSSINET S	KLEMMBÜCH	FLANGE BUSHING	D=127/75 (ROTOR)	8215660	1	XX																																																							
10	KIL	CLAVETTE	KEIL	KEY	R 20X12X90 H7 SL	9-50015	1	XX																																																							
11	SKRUV	VIS	SCHRAUBE	SCREW	HHS M6S 12X50	9-40056	4	XX	A,B,D																																																						
					HHS M6S 16X60	9-40055	4	XX	F,G																																																						
12	BRICKA	RONDELLE	SCHEIBE	WASHER	HARDENED M12 AMF DI	9-40060	4	XX	A,B,D																																																						
					HARDENED 30,0	9-40435	4	XX	F,G																																																						
<table border="1"> <thead> <tr> <th rowspan="3">POS (13) MOTOR</th> <th colspan="3">50 HZ (MF053138, MF053107, MF053156)</th> <th colspan="3">60HZ (MF053153, MF053119, MF053157)</th> </tr> <tr> <th>1</th> <th>2</th> <th>3</th> <th>1</th> <th>2</th> <th>3</th> </tr> <tr> <th>(200-219V / 50HZ)</th> <th>(220-240V / 50HZ)</th> <th>(380-420V / 50HZ)</th> <th>(200-219V / 60HZ)</th> <th>(440-480V / 60HZ)</th> <th>(380-420V / 60HZ)</th> </tr> </thead> <tbody> <tr> <td>A</td> <td colspan="6">10 HP {7.5 KW}</td> </tr> <tr> <td>B</td> <td colspan="6">15 HP {11.0 KW}</td> </tr> <tr> <td>D</td> <td colspan="6">25 HP {18.7 KW}</td> </tr> <tr> <td>F</td> <td colspan="6">40 HP {29.8 KW}</td> </tr> <tr> <td>G</td> <td colspan="6">50 HP {37.3 KW}</td> </tr> </tbody> </table>										POS (13) MOTOR	50 HZ (MF053138, MF053107, MF053156)			60HZ (MF053153, MF053119, MF053157)			1	2	3	1	2	3	(200-219V / 50HZ)	(220-240V / 50HZ)	(380-420V / 50HZ)	(200-219V / 60HZ)	(440-480V / 60HZ)	(380-420V / 60HZ)	A	10 HP {7.5 KW}						B	15 HP {11.0 KW}						D	25 HP {18.7 KW}						F	40 HP {29.8 KW}						G	50 HP {37.3 KW}					
POS (13) MOTOR	50 HZ (MF053138, MF053107, MF053156)			60HZ (MF053153, MF053119, MF053157)																																																											
	1	2	3	1	2	3																																																									
	(200-219V / 50HZ)	(220-240V / 50HZ)	(380-420V / 50HZ)	(200-219V / 60HZ)	(440-480V / 60HZ)	(380-420V / 60HZ)																																																									
A	10 HP {7.5 KW}																																																														
B	15 HP {11.0 KW}																																																														
D	25 HP {18.7 KW}																																																														
F	40 HP {29.8 KW}																																																														
G	50 HP {37.3 KW}																																																														
<b>CONSULT FACTORY</b>																																																															
EXAMPLE: MOTOR 15 KW & 220-240V/50 HZ = ART NO 9-92281 (XX = 1418, 1424, 1436)																																																															

(Continued)

Transmission, Motor, Fly wheel (continued from previous)

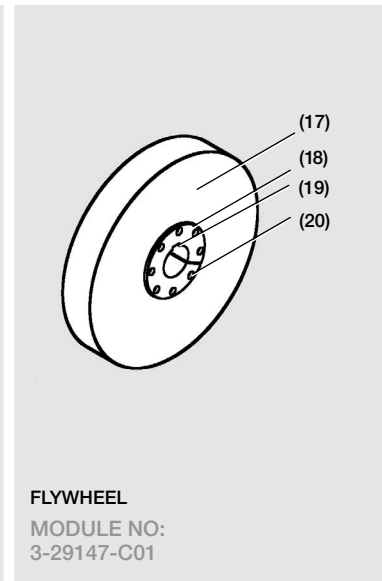
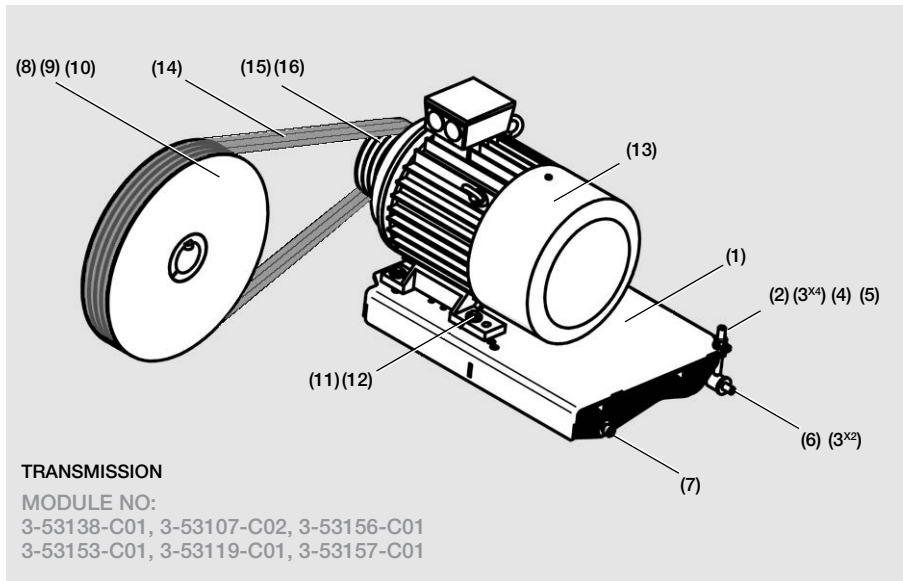

P	SE	FR	DE	ENGLISH	SPECIFICATION	ART NO	Q	M	V
13	MOTOR	MOTEUR	MOTOR	MOTOR		(REFER TO TABLE BELOW)			
14	KILREM	COURROIE TR	KEILRIEMEN	V-BELT	XPB 2240	9-30245	3	XX	A, B
							4	XX	D
							4	XX	F, G
15	REMSKIVA	POULIE	RIEMENSCHIEI	PULLEY	MOTOR 4 SPB 187	8307053	1	XX	50 HZ
					MOTOR SPB4 DW=150	8339303	1	XX	60 HZ
16	KLÄMBUSSN	COUSSINET S	KLEMMBÜCH	EXPANDING BUSHI	TAPER-LOCK TL2517 D=38	9-30118	1	XX	A
					TAPER-LOCK TL2517 D=42	9-30119	1	XX	B
					TAPER-LOCK TL2517 D=48	9-30225	1	XX	D
					TAPER-LOCK TL2517 D=55	9-30298	1	XX	F
					TAPER-LOCK TL2517 D=60	9-30305	1	XX	G
17	SVÄNGHJUL	VOLANT MOTE	SCHWUNGRA	FLYWHEEL	D=507-3589-F-DI	9-30138	1	1418	
18	KLÄMBUSSN	COUSSINET S	KLEMMBÜCH	FLANGE BUSHING	D=127/75	8215660	1	1418	
19	KIL	CLAVETTE	KEIL	KEY	R 20X12X90 H7 SL	9-50015	1	1418	
20	SKRUV	VIS	SCHRAUBE	SCREW	SHS MC6S 10X40 UNBR	9-40004	8	1418	

POS (13) MOTOR			50 HZ (MF053138, MF053107, MF053156)			60HZ (MF053153, MF053119, MF053157)		
			1	2	3	1	2	3
			(200-219V / 50HZ)	(220-240V / 50HZ)	(380-420V / 50HZ)	(200-219V / 60HZ)	(440-480V / 60HZ)	(380-420V / 60HZ)
3B	A	10 HP {7.5 KW}	<b>CONSULT FACTORY</b>					
	B	15 HP {11.0 KW}						
4B	D	25 HP {18.7 KW}						
	F	40 HP {29.8 KW}						
	G	50 HP {37.3 KW}						

EXAMPLE: MOTOR 15 KW & 220-240V/50 HZ = ART NO 9-92281 (XX = 1418, 1424, 1436)

**Safety Transmission**

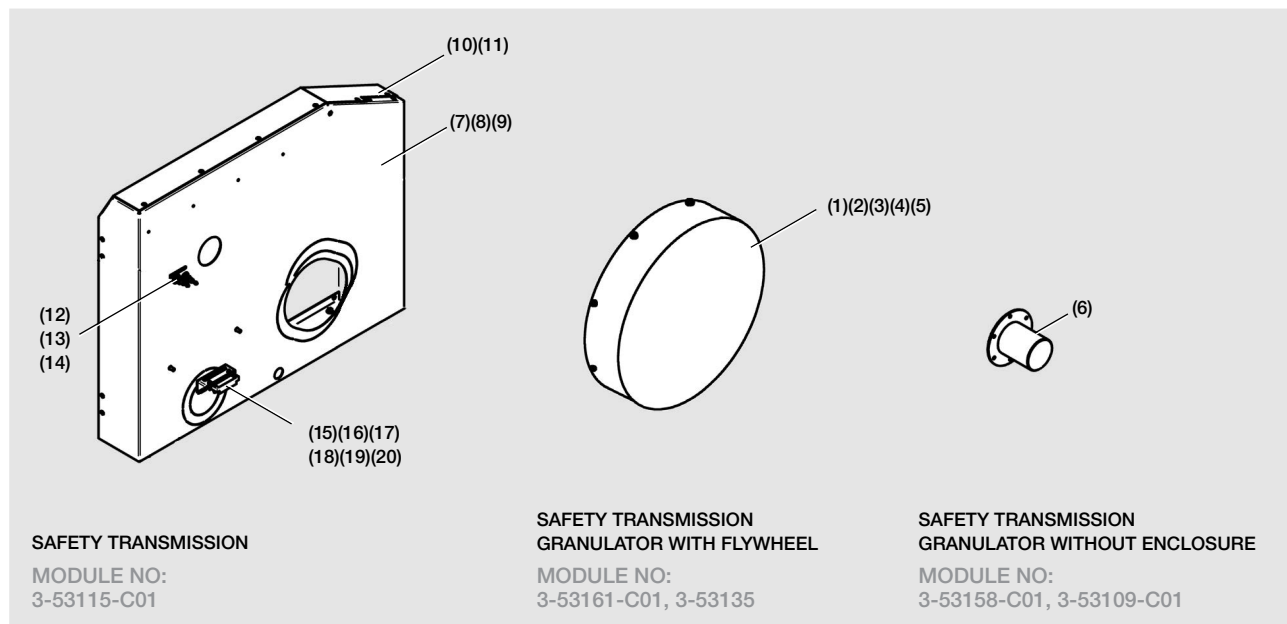

SAFETY TRANSMISSION

MODULE NO:  
3-53115-C01

SAFETY TRANSMISSION  
GRANULATOR WITH FLYWHEEL

MODULE NO:  
3-53161-C01, 3-53135

SAFETY TRANSMISSION  
GRANULATOR WITHOUT ENCLOSURE

MODULE NO:  
3-53158-C01, 3-53109-C01

P	SE	FR	DE	ENGLISH	SPECIFICATION	ART NO	Q	M	V
1	SVÄNGHJULSS	PROTECTION	SCHUTZ SCH	FLYWHEEL GUARD	INNER	8353554	1	XX	F
2	SVÄNGHJULSS	PROTECTION	SCHUTZ SCH	FLYWHEEL GUARD	OUTER	8353557	1	XX	
3	LAGER LOCK	PLAQUE	DECKEL LAGE	BEARING COVER	BLACK	8353357	1	XX	
4	SKRUV	VIS	SCHRAUBE	SCREW	TAPPING TAPTITE 8X16	9-40444	8	XX	
5	SKRUV	VIS	SCHRAUBE	SCREW	SHS MC6S 8X30	9-40007	6	XX	
6	SKYDD	PROTECTION	SCHUTZ	PROTECTION	SHAFT, BLACK	8353435	1	XX	WE
7	KÅPA	CAPOT	HAUBE	COVER	L INNER AND OUTER	8253433	1	XX	
8	SKRUV	VIS	SCHRAUBE	SCREW	TAPPING TAPTITE 8X16	9-40444	6	XX	
9	MUTTER	ËCROU	MUTTER	NUT	BLIND RIVET M 8 STEEL	9-50750	26	XX	
10	KAPSLING	ENCAPSULAG	KAPSELUNG	ENCLOSURE		8253434	1	XX	
11	SKRUV	VIS	SCHRAUBE	SCREW	SHS K6SF 8X16 10.9	9-40885	22	XX	
12	GIVARE	CAPTEUR	GEBER	TRANSMITTER	STAND STILL MONITO	8353431	1	XX	
13	SENSOR	SENSOR	SENSOR	SENSOR	IA12DSN04PO-3M	9-11758	2	XX	
14	SKRUV	VIS	SCHRAUBE	SCREW	SHS MF6S 8X20 10.9	9-41041	3	XX	
15	FÅSTE	FIXATION	BEFESTIGUNG	BRACKET	SWITCH MAGNET KROS	8353432	1	XX	
16	BRYTARE MAG	INTERUPTEUR	SCHALTER	SWITCH MAGNET	BNS 33-12Z	9-11727	1	XX	
17	BRYTARE MAG	INTERUPTEUR	SCHALTER	SWITCH MAGNET	FOR, BPS 33-2326	9-11728	1	XX	
18	SKRUV	VIS	SCHRAUBE	SCREW	SHS K6SF 8X16 10.9	9-40885	24	XX	
19	SKRUV	VIS	SCHRAUBE	SCREW	SHS MC6S 4X25	9-40638	4	XX	
20	MUTTER	ËCROU	MUTTER	NUT	LOC-KING M 4 LOW	9-40315	4	XX	

(XX = 1418, 1424, 1436) (F= FLYWHEEL) (WE = WITHOUT ENCLOSURE)

### Safety Enclosure

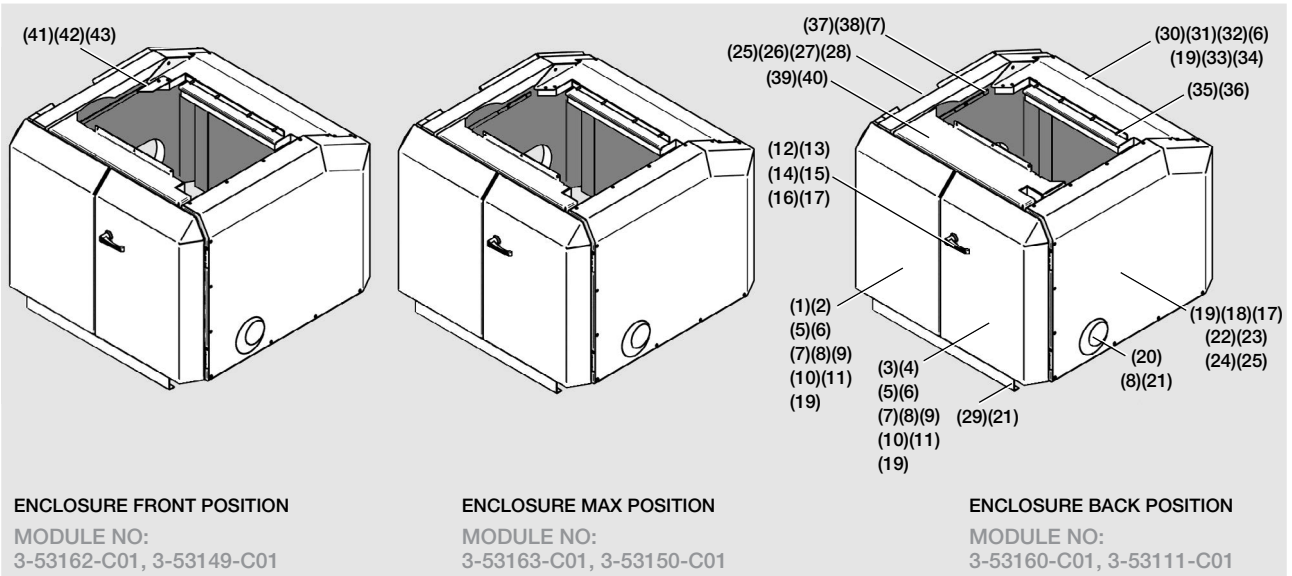

P	SE	FR	DE	ENGLISH	SPECIFICATION	ART NO	Q	M	V
1	DÖRR V	PORTE	TÜR L	DOOR L	---	8153668	1	1418	
						8153518	1	1424	
2	BAKPLÅT V	PLAQUE ARR	BLECH HINT L	BACK PLATE L	DOOR L	8353670	1	1418	
						8353525	1	1424	
3	DÖRR H	PORTE	TÜR R	DOOR R	---	8153669	1	1418	
						8153519	1	1424	
4	BAKPLÅT H	PLAQUE ARR	BLECH HINT R	BACK PLATE R	DOOR R	8353671	1	1418	
						8353526	1	1424	
5	GÅNGJÄRN	CHARNIÈRE	SCHARNIER	HINGE	STAINLESS STEEL BLAC	9-50585	4	XX	
6	LIST	BAGUETTE	LEISTE	LIST	CLIPS ART. NR. 53	9-70156	1	XX	
7	LIST	BAGUETTE	LEISTE	LIST	EPDM BLACK	9-90922	1	XX	
8	MUTTER	ÈCROU	MUTTER	NUT	BLIND RIVET M 8 STEEL	9-50750	38	XX	
9	SKRUV	VIS	SCHRAUBE	SCREW	MONTAGE DRILWICKPH4	9-40750	36	XX	
10	ABSORBENT	ISOLATION	SCHALLSCHU	ABSORBER	DOOR FRONT	(3-53662)	2	1418	
						(3-53656)	2	1424	
11	ABSORBENT	ISOLATION	SCHALLSCHU	ABSORBER	DOOR BACK	(3-53663)	2	1418	
						(3-53657)	2	1424	
12	LÅS	VERROU	SCHLOSS	LOCK	DOOR	9-50756	1	XX	
13	SKRUV	VIS	SCHRAUBE	SCREW	SHS MC6S 8X35	9-40126	1	XX	
14	DISTANS	ENTRETOISE	ABSTANDSTÜ	DISTANCE	LOCK DOOR	8345341	1	XX	
15	MUTTER	ÈCROU	MUTTER	NUT	BLIND RIVET M 6 HEX	9-50550	7	XX	
16	SKRUV	VIS	SCHRAUBE	SCREW	SHS MC6S 6X30	9-40077	5	XX	
17	MUTTER	ÈCROU	MUTTER	NUT	M6M M 6	9-40027	2	XX	
18	KAPSLING	ENCAPSULAG	KAPSELUNG	ENCLOSURE		(2-53521)	1	XX	
19	SKRUV	VIS	SCHRAUBE	SCREW	SHS K6SF 8X16 10.9	9-40885	45	1418	
							49	1424	
20	KÅPA	CAPOT	HAUBE	COVER	R INNER AND OUTER	8253520	1	XX	
21	SKRUV	VIS	SCHRAUBE	SCREW	TAPPING TAPTITE 8X16	9-40444	13	XX	
22	ABSORBENT	ISOLATION	SCHALLSCHU	ABSORBER	COVER R FRONT	(3-53649)	1	XX	
23	ABSORBENT	ISOLATION	SCHALLSCHU	ABSORBER	COVER R TOP	(3-53650)	1	XX	
24	ABSORBENT	ISOLATION	SCHALLSCHU	ABSORBER	COVER R SIDE	(4-53651)	1	XX	
25	ABSORBENT	ISOLATION	SCHALLSCHU	ABSORBER	COVER R BACK	(3-53651)	2	XX	

(XX = 1418, 1424, 1436)

(B = BACK POSITION)

(F = FRONT POSITION)

(M= MAX POSITION)

(Continued)

Safety Enclosure (continued from previous)

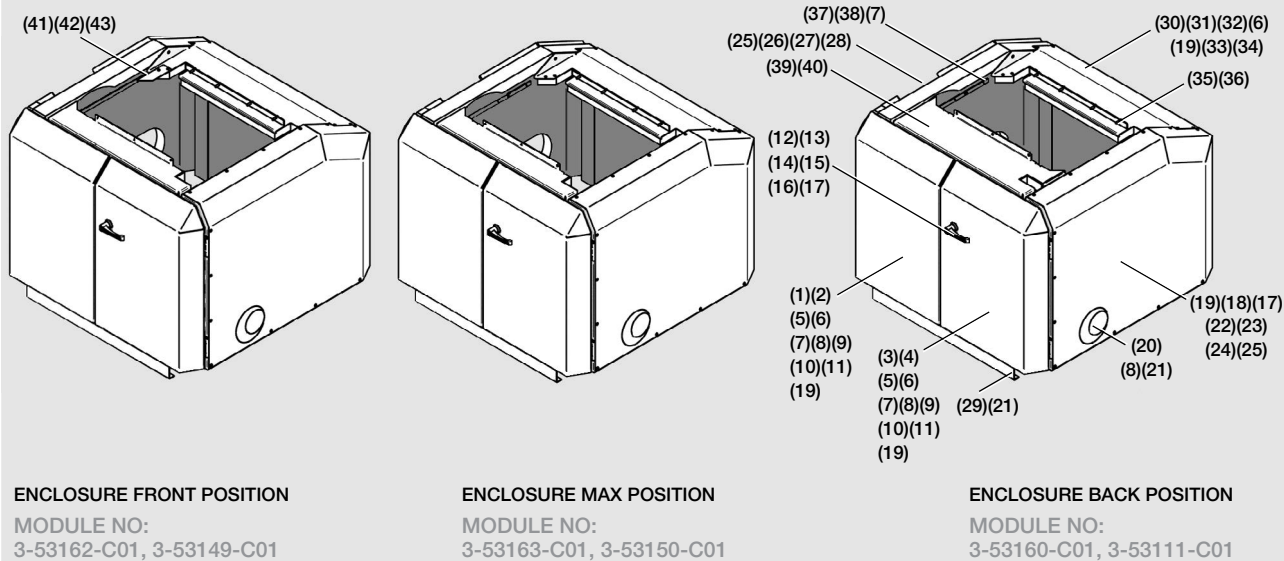

P	SE	FR	DE	ENGLISH	SPECIFICATION	ART NO	Q	M	V
26	ABSORBENT	ISOLATION	SCHALLSCHU	ABSORBER	COVER L FRONT	(3-53653)	1	XX	
27	ABSORBENT	ISOLATION	SCHALLSCHU	ABSORBER	COVER L TOP	(3-53654)	1	XX	
28	ABSORBENT	ISOLATION	SCHALLSCHU	ABSORBER	COVER L SIDE	(3-53655)	1	XX	
29	BOTTENPLÅT	PLAQUE FOND	BODENBLECH	BOTTOM PLATE	---	8353675	1	1418	
						8353523	1	1424	
30	KÅPA	CAPOT	HAUBE	COVER	BACK	8253674	1	1418	
						8253522	1	1424	
31	HANDTAG		GRIFFE	HANDLE	P2-53 SOUTHCO	9-50757	2	XX	
32	LIST	BAGUETTE	LEISTE	LIST	SEALING/CLIPS	9-70040	1	XX	
33	ABSORBENT	ISOLATION	SCHALLSCHU	ABSORBER	COVER BACK UPPER	(3-53664)	1	1418	
						(3-53658)	1	1424	
34	ABSORBENT	ISOLATION	SCHALLSCHU	ABSORBER	COVER BACK LOWER	(3-53665)	1	1418	
						(3-53659)	1	1424	
35	TÅTNING		DICHTUNG	SEALING	BACK PIECE, BLACK	8353676	1	1418	
						8353528	1	1424	
36	SKRUV	VIS	SHRAUBE	SCREW	SHS MC6S 8X25	9-40097	4	XX	
37	HÅLLARE	SUPPORT	HALTER	HOLDER	LIST	8353524	2	XX	
38	POP-NIT	RIVET	NIET	POP-RIVET	AL PRESSURE TIGHT	9-40623	8	XX	
39	DISTANS	ENTRETOISE	ABSTANDSTÜ	DISTANCE	HOPPER	8253672	1	1418	B
						8253527	1	1424	
						8253673	1	1418	F, M
						8253542	1	1424	
40	ABSORBENT	ISOLATION	SCHALLSCHU	ABSORBER	DISTANCE	(3-53666)	1	1418	B
						(3-53660)	1	1424	
						(3-53667)	1	1418	F, M
						(3-53661)	1	1424	
41	PLÅT	PLAQUE	PLATTE	SIDE PLATE	SEALING BACK, BLACK	8453479	2		
42	SKRUV	VIS	SCHRAUBE	SCREW	SHS K6S 6X14	9-40800	4	XX	F
43	MUTTER	ECROU	MUTTER	NUT	BLIND RIVET M 6 STEEL	9-50749	4		

(XX = 1418, 1424, 1436)

(B = BACK POSITION)

(F = FRONT POSITION)

(M= MAX POSITION)

### Safety Electrical cabinet

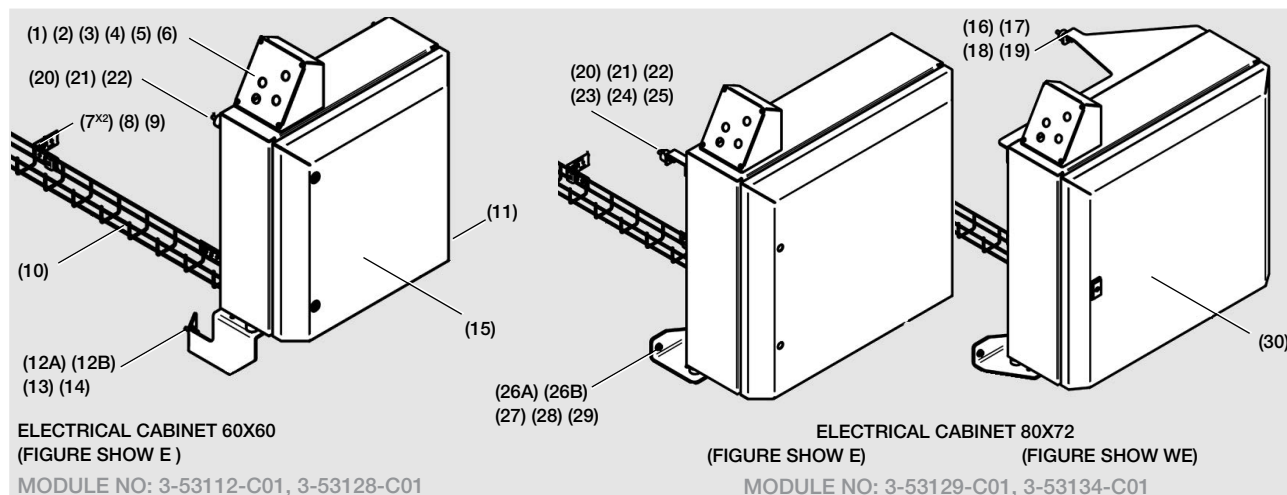

P	SE	FR	DE	ENGLISH	SPECIFICATION	ART NO	Q	M	V
1	MANÖVERPAN	PANN COMMA	BEDIENPULT	OPERATING PANEL	ELECTRICAL COM	8453467	1	XX	60X60
2	MANÖVERPAN	PANN COMMA	BEDIENPULT	OPERATING PANEL	ELECTRICAL COM	8353465	1	XX	
3	MUTTER	ÉCROU	MUTTER	NUT	M6M M 6	9-40027	6	XX	
4	SKRUV	VIS	SCHRAUBE	SCREW	SHS K6S 6X16	9-40801	6	XX	
5	MUTTER	ÉCROU	MUTTER	NUT	BLIND RIVET M 5 STEEL	9-50247	4	XX	
6	SKRUV	VIS	SCHRAUBE	SCREW	SHS K6S 5X16	9-40796	4	XX	
7	SKRUV	VIS	SCHRAUBE	SCREW	TAPPING TAPTITE 8X16	9-40444	2	XX	
8	KABELSTEGE	SUPP CABL	KABELHALTER	CABLE LADDER	JOINT B2	9-11464	2	XX	
9	KABELSTEGE	SUPP CABLE	KABELHALTER	CABLE LADDER	ANGLE B27	9-11466	2	XX	
10	KABELSTEGE	SUPP KABL	KABELHALTER	CABLE LADDER		(3-54460)	1	1412	
						(3-54456)	1	1418	
						(3-45501)	1	1424	
11	FÄSTE	FIXATION	BEFESTIGUNG	BRACKET	ELECTRICAL CAB. BLAC	8353473	1	XX	60X60
12A	FÄSTE	FIXATION	BEFESTIGUNG	BRACKET	ELECTRICAL CAB. BLAC	8353474	1	XX	
12B	SKRUV	VIS	SCHRAUBE	SCREW	TAPPING TAPTITE 8X16	9-40444	4	XX	
13	MUTTER	ÉCROU	MUTTER	NUT	SHS K6S 8X20	9-40317	4	XX	
14	DÄMPARE	AMORTISSEU	DÄMPFER	DAMPER	D=30 X 20 M8X20	9-90571	2	XX	
15	TOMKAPSLING	ENCAPSULAG	KAPSELUNG	CUBICLE	600X600X265	9-93806	1	XX	
16	FÄSTE	FIXATION	BEFESTIGUNG	BRACKET	ELECTRICAL CAB. BLAC	8353464	1	XX	60X60, WE
						8353475	1	XX	80X72, WE
17	MUTTER	ÉCROU	MUTTER	NUT	SHS K6S 8X20	9-40317	3	XX	WE
18	SKRUV	VIS	SCHRAUBE	SCREW	SHS K6S 8X20	9-40662	2	XX	
19	DÄMPARE	AMORTISSEU	DÄMPFER	DAMPER	D=30 X 20 M8X20	9-90571	1	XX	
20	MUTTER	ÉCROU	MUTTER	NUT	BLIND RIVET M 8 STEEL	9-50276	2	XX	E
21	DÄMPARE	AMORTISSEU	DÄMPFER	DAMPER	D=30 X 20 M8X20	9-90571	2	XX	
22	MUTTER	ÉCROU	MUTTER	NUT	LOC-KING M 8	9-40317	2	XX	
23	FÄSTE	FIXATION	BEFESTIGUNG	BRACKET	ELECTRICAL CAB. BLA	8453619	2	XX	80X72, E
24	MUTTER	ÉCROU	MUTTER	NUT	LOC-KING M 8	9-40317	2	XX	
25	SKRUV	VIS	SCHRAUBE	SCREW	SHS K6S 8X20	9-40662	2	XX	
26A	FÄSTE	FIXATION	BEFESTIGUNG	BRACKET	800X720X275 EL. BLACK	8353618	1	XX	80X72, WE
26B	SKRUV	VIS	SCHRAUBE	SCREW	TAPPING TAPTITE 8X16	9-40444	2	XX	
27	MUTTER	ÉCROU	MUTTER	NUT	SHS K6S 8X20	9-40317	2	XX	
28	DÄMPARE	AMORTISSEU	DÄMPFER	DAMPER	D=30 X 15 M8X20	9-50754	2	XX	
29	SKRUV	VIS	SCHRAUBE	SCREW	SHS MF6S 8X12 10.9	9-41053	2	XX	
30	TOMKAPSLING	ENCAPSULAG	KAPSELUNG	CUBICLE	800X720X290	9-93778	1	XX	80X72

(XX = 1412, 1418, 1424) (60X60 = ELECTRICAL CABINET 600X600X265) (80X72 = ELECTRICAL CABINET 800X720X290)

(E = GRANULATOR WITH ENCLOSURE) (WE = GRANULATOR WITHOUT ENCLOSURE)

**Body**

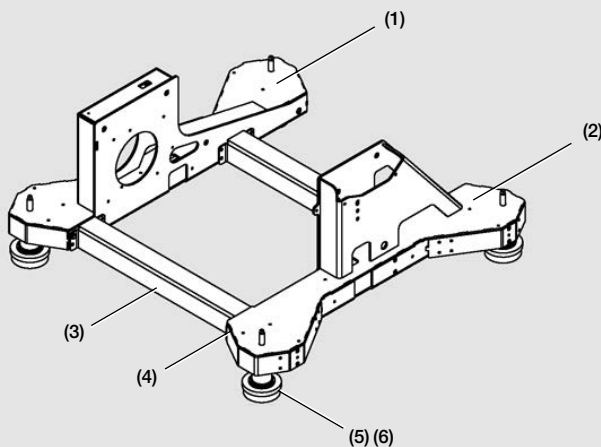

**BODY MACHINE SHOE**

MODULE NO:  
3,-53140-C01, 3-53110-C02, 3-53142-C01

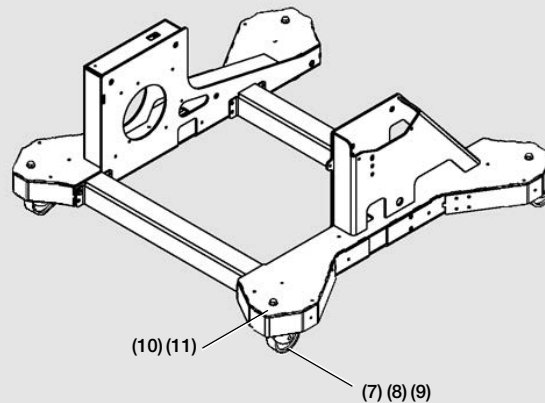



**BODY WHEELS**

MODULE NO:  
3,-53140-C01, 3-53110-C02, 3-53142-C01

P	SE	FR	DE	ENGLISH	SPECIFICATION	ART NO	Q	M	V
1	STATIV	BÂTI	GESTELL	STAND	L BLACK	8253404	1	XX	
2	STATIV	BÂTI	GESTELL	STAND	R BLACK	8253409	1	XX	
3	STAG	ETAI	STREBE	SUPPORT	STAND, BLACK	8354420	2	1418	
						8253412	2	1424	
						8253645	2	1436	
4	SKRUV	VIS	SCHRAUBE	SCREW	TAPPING TAPTITE 8X16	9-40444	8	XX	
5	MASKINSKO	SEMELLE	MASCHFUSS	MACHINE SHOE	SUNNE SIZE 2	9-50308	4	XX	MS
6	DISTANS	ENTRETOISE	ABSTANDSTÜ	DISTANCE	MACHINE SHOE, BLACK	8453413	4	XX	
7	HJUL	ROUE	RAD	CASTOR	SD4-100-101	9-50056	4	XX	W
8	DISTANS	ENTRETOISE	ABSTANDSTÜ	DISTANCE	CASTOR, BLACK	8453416	4	XX	
9	MUTTER	ÉCROU	MUTTER	NUT	LOC-KING M 12	9-40059	4	XX	
10	BRICKA	VIS	SCHRAUBE	SCREW	BRB 13,0	9-40155	4	XX	
11	SKRUV	VIS	SCHRAUBE	SCREW	HHS M6S 12X80	9-40627	4	XX	
(MS = BODY MACHINE SHOE)                      (W = BODY WHEELS)                      (XX = 1418, 1424, 1436)									

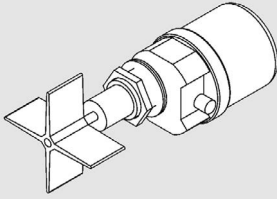
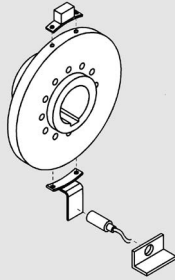
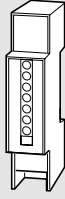
**Options, Level switch, Hours counter, Stand still/Speed monitor, Current relay**

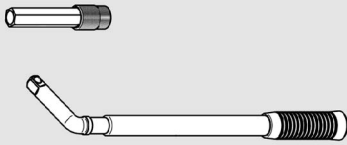
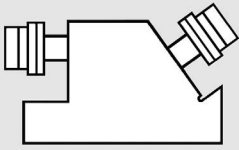
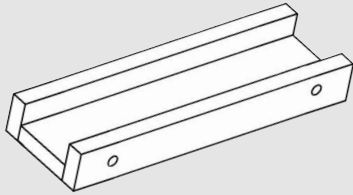
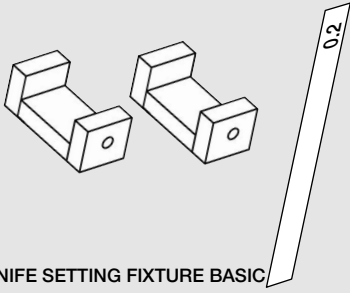
<p>(1)</p>  <p>LEVEL SWITCH, TYPE PADDLE SWITCH</p>	<p>(2)</p>  <p>STANDSTILL MONITOR / SPEED MONITOR</p>	<p>(3)</p>  <p>HOURS COUNTER</p>
<p>(4)</p>  <p>CURRENT RELAY</p>	<p>(5)</p>  <p>TOOLS MODULE NO: 3-53152-C01, 3-53113-C01</p>	
<p>(6)</p>  <p>KNIFE GRINDING FIXTURE MODULE NO: XXXXXXXXXX</p>	<p>(7)</p>  <p>KNIFE SETTING FIXTURE LONG MODULE NO: 3-53113-C01</p>	<p>(8)</p>  <p>KNIFE SETTING FIXTURE BASIC MODULE NO: 3-53113-C01</p>

P	SE	FR	DE	ENGLISH	SPECIFICATION	ART NO	Q	M	V
1	NIVÅVAKT	INDIC. NIV	NIVÄWÄCHT	LEVEL INDICATOR	PADDLE SWITCH	*			
2	STILLES.VAK	INDIC. ARRET	STILL.WÄCH	STAND STILL WA	----	*			
3	TIMRÄKNARE	COMPT. HOU	STUNDENZÄH	HOURS COUNTER	----	*			
4	STRÖMRELÄ	RELAJ SÉLEC	STROMRELAJ	CURRENT RELAY	CROUZET	*			
5	VERKTYG	OUTIL	WERKZEUG	TOOLS	TELESCOPE WRENCH	9-70294	1		
					BITS 1/2" INSEX	8453535	1		
					HOLDER HOSE WITH LATCH ABC	9-10855	1		
6	KNIVSLIPFIXT	DISPOSITIF A	SCHLEIFVORR	KNIFE GRINDING	FIXTURE	*	1		
					WASHER	*	3		
					WASHER	*	1		
					SCREW	*	1		
7	KNIVINSTÄLL	DISPOSITIF C	MESSERVORR	KNIFE SETTING	FIXTURE LONG	*	1		
					DISTANCE	*	1		
8	KNIVINSTÄLL	DISPOSITIF C	MESSERVORR	KNIF SETTING	FIXTURE W=74,2X4	8353538	1		
					FIXTUREW=68,2X4	8353537	1		
					FEELER GAUGE	*	1		

\* WHEN ORDERING THIS DETAIL : SPECIFY ENGLISH DESCRIPTION AND SPECIFICATION + THE SERIAL NO OF YOUR GRANULATOR.

**Material transport, Blower, Belt Conveyor, Dust separator system**

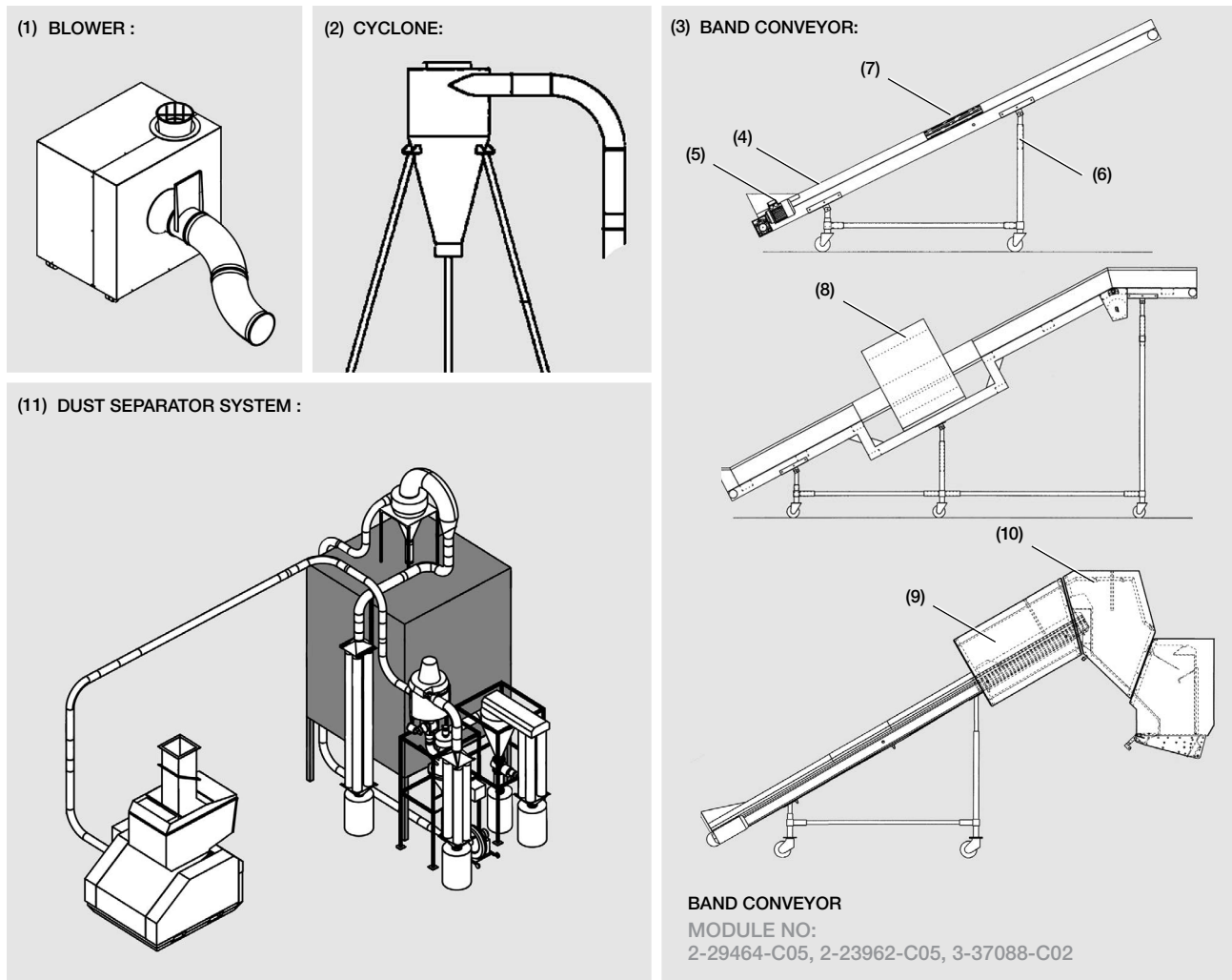

P	SE	FR	DE	ENGLISH	SPECIFICATION	ART NO	Q	-X	
1	FLÄKT	VENTILATEUR	GEBLÄSE	BLOWER COMPLETE	F7 F15 F25	REFER TO PAGE 9:25	1	U	
2	CYKLON	CYCLONE	CYKLON	CYCLONE	AX7.5 AX12 AX16	* * *	1	AX	
3	BANDTRANSP	CONV BAND	BANDFÖREDE	BAND CONV COMPLET	B450 B600 B900	* * *	1 1 1	B	
4	BAND	BAND	BAND	BAND	BAND CONVEYOR	*	1		
5	MOTOR	MOTEUR	MOTOR	MOTOR	BAND CONVEYOR	*	1		
6	STATIV	FONDATION	GESTELL	STAND	BAND CONVEYOR	*	1		
7	MET DETEKT	DÉT MÉTAL	MET DETEKT	METAL DETECTOR	AREA	*, **	1		
8	MET DETEKT	DÉT MÉTAL	MET DETEKT	METAL DETECTOR	TUNNEL	*, **	1		
9	LJUDFÄLLA	SILENCIEUX	SCHALLHAUB	SOUND TRAP		*	1		
10	INLOPP	ENTRÉE	EINLASS	INLET		***	1		
11	DAMMSEP SY	FILTR POUSS	STAUBFILTER	DUST SEPARATOR SYS	TRACS DS400 TP2119 TP2111	** ** ** **	1		DS

(U = BLOWER) (B = BELT CONVEYOR) (DS = DUST SEPARATOR SYSTEM) (AX = CYCLONE)

\* WHEN ORDERING THIS DETAIL SPECIFY: ENGLISH DESCRIPTION AND SPECIFICATION + THE SERIAL NO OF YOUR GRANULATOR.

\*\* BEFORE ORDERING SPARE PARTS TO THIS DETAIL, PLEASE REFER TO THE SEPARATE INSTRUCTION MANUAL.

\*\*\* BEFORE ORDERING THIS DETAIL PLEASE REFER TO PAGE 9:1 "HOPPER" AND PAGE 9:2 "FLAPS".

**Blower**

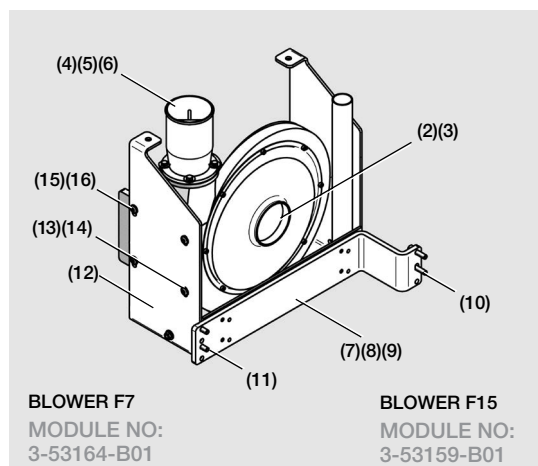

**BLOWER F7**  
MODULE NO:  
3-53164-B01

**BLOWER F15**  
MODULE NO:  
3-53159-B01

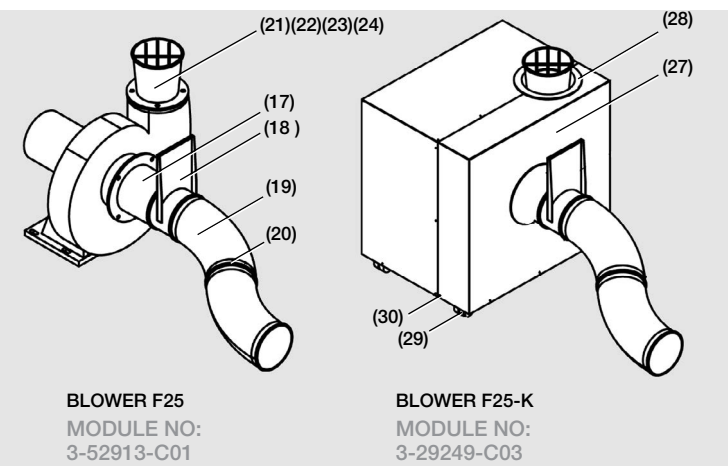

**BLOWER F25**  
MODULE NO:  
3-52913-C01

**BLOWER F25-K**  
MODULE NO:  
3-29249-C03

P	SE	FR	DE	ENGLISH	SPECIFICATION	ART NO	Q	V
1	FLÄKT	VENTILATEUR	BLASER	BLOWER	F7, F15, F25	REFER TO TABLE BELOW		
2	STOS	RACCORD	STUTZEN	FLANGE	INL F7-D=101 L=20	8330267	1	F7, F15
3	SKRUV	VIS	SCHRAUBE	SCREW	SHS MC6S 6X16	9-40039	8	
4	STOS	RACCORD	STUTZEN	FLANGE	OUTL F7-OK100 L=160	8313138	1	F7
					OUTL F15-OK100 L=150	8310332	1	F25
5	SKRUV	VIS	SCHRAUBE	SCREW	HHS M6S 8X20	9-40426	4	F7, F15
6	BRICKA	RONDELLE	SCHEIBE	WASHER	BRB 8,4 DIN-9021 Y	9-40592	4	
7	FÄSTE	FIXATION	BEFESTIGUNG	BRACKET	BLOWER	8253647	1	
8	SKRUV	VIS	SCHRAUBE	SCREW	SHS MC6S 10X16	9-40201	4	
9	BRICKA	RONDELLE	SCHEIBE	WASHER	BRB 10,5 FZB	9-40031	4	
10	SKRUV	VIS	SCHRAUBE	SCREW	SHS MC6S 10X40 UNBR	9-40004	2	
11	SKRUV	VIS	SCHRAUBE	SCREW	SHS MF6S 10X30	9-40347	2	
12	HÅLLARE	SUPPORT	HALTER	HOLDER	BLOWER BLACK	8354506	1	
13	HÅLLARE	SUPPORT	HALTER	HOLDER	BLOWER F7/F15 BLACK CHR	8424655	1	
14	SKRUV	VIS	SCHRAUBE	SCREW	SHS MK6SF 10X40	9-41056	4	
15	MUTTER	ÉCROU	MUTTER	NUT	LOC-KING M 10	9-40015	2	
16	BRICKA	RONDELLE	SCHEIBE	WASHER	BRB 10,5 FZB	9-40031	2	
17	STOS	RACCORD	STUTZEN	FLANGE	INL F25-OK160 L=150	8208679	1	F25, F25-K
18	SPJÄLL	REGULATEUR	DROSSEL	SLIDING DAMPER	OK160 L=100	9-20197	1	
19	RÖR	TUYAU	ROHR	PIPE BEND	BEND OK160 45 DEG NOAB	8417781	2	
20	SNABBKOPPL	RACCORD RA	SCHNELLKUP	QUICK COUPLING	OK160	9-20107	4	
21	STOS	RACCORD	STUTZEN	FLANGE	OUTL F25-OK160 L=160	8208684	1	
22	SKRUV	VIS	SCHRAUBE	SCREW	HHS M6S 12X40	9-40022	8	
23	MUTTER	ÉCROU	MUTTER	NUT	M6M M 12 FZB	9-40207	8	
24	BRICKA	RONDELLE	SCHEIBE	WASHER	BRB 13,0	9-40155	12	
25*	KONTAKTDON	CONTACTEUR	NETZSTECKE	CONNECTOR	6-POLE CABLE HOOD	9-11006	1	
26*	KONTAKTDON	CONTACTEUR	NETZSTECKE	CONNECTOR	6-POLE HIGH CHASSIS	9-11032	1	
27	BULLERHUV	CAPOT ANTI	SCHALLDÄMP	SOUND HOOD	F25	8206036	1	F25-K
28	HJUL	ROUE	RAD	CASTOR	D=50 MM 41050002015	9-50427	4	
29	TÄTNINGSRING	JOINT D'ÉTAN	DICHTUNGSRI	SEALING RING	PRESSED 230/130X4	9-70153	2	
30	SKRUV	VIS	SCHRAUBE	SCREW	MONTAGE DRILWICKPH4,8X16	9-40750	20	

BLOWER TABLE		1	2	3	4	5
		(200-220V / 50HZ)	(200-220V / 60HZ)	(380V / 60HZ)	(220-420V / 50HZ) (380-420V / 50HZ) (655-724V / 50HZ)	(440-480V / 60HZ)
A	F7	9-20877	9-20878	9-92187	9-920206	9-92828
A	F15	9-20879	9-20880	9-92136	9-20421	9-92829
A	F25	9-20881	9-20882	9-92312	9-20210	

## We're Here to Help

Conair has made the largest investment in customer support in the plastics industry. Our service experts are available to help with any problem you might have installing and operating your equipment. Your Conair sales representative also can help analyze the nature of your problem, assuring that it did not result from misapplication or improper use.

Additional manuals and prints for your Conair equipment may be ordered through the Customer Service or Parts Department for a nominal fee. Most manuals can be downloaded free of charge from the product section of the Conair website. [www.conairgroup.com](http://www.conairgroup.com)

## How to Contact Customer Service

To contact Customer Service personnel, call:



 **NOTE:** Normal operating hours are 8:00 am - 5:00 pm (EST). After hours emergency service is available at the same phone number.

You can commission Conair service personnel to provide on-site service by contacting the Customer Service Department.

## Before You Call...

**If you do have a problem, please complete the following checklist before calling Conair:**

- Make sure you have all model, control type from the serial tag, and parts list numbers for your particular equipment. Service personnel will need this information to assist you.
- Make sure power is supplied to the equipment.
- Make sure that all connectors and wires within and between control systems and related components have been installed correctly.
- Check the troubleshooting guide of this manual for a solution.
- Thoroughly examine the instruction manual(s) for associated equipment, especially controls. Each manual may have its own troubleshooting guide to help you.

## Equipment Guarantee

Conair guarantees the machinery and equipment on this order, for a period as defined in the quotation from date of shipment, against defects in material and workmanship under the normal use and service for which it was recommended (except for parts that are typically replaced after normal usage, such as filters, liner plates, etc.). Conair's guarantee is limited to replacing, at our option, the part or parts determined by us to be defective after examination. The customer assumes the cost of transportation of the part or parts to and from the factory.

## Performance Warranty

Conair warrants that this equipment will perform at or above the ratings stated in specific quotations covering the equipment or as detailed in engineering specifications, provided the equipment is applied, installed, operated and maintained in the recommended manner as outlined in our quotation or specifications.

Should performance not meet warranted levels, Conair at its discretion will exercise one of the following options:

- Inspect the equipment and perform alterations or adjustments to satisfy performance claims. (Charges for such inspections and corrections will be waived unless failure to meet warranty is due to misapplication, improper installation, poor maintenance practices or improper operation.)
- Replace the original equipment with other Conair equipment that will meet original performance claims at no extra cost to the customer.
- Refund the invoiced cost to the customer. Credit is subject to prior notice by the customer at which time a Return Goods Authorization Number (RGA) will be issued by Conair's Service Department. Returned equipment must be well crated and in proper operating condition, including all parts. Returns must be prepaid.

Purchaser must notify Conair in writing of any claim and provide a customer receipt and other evidence that a claim is being made.

## Warranty Limitations

**Except for the Equipment Guarantee and Performance Warranty stated above, Conair disclaims all other warranties with respect to the equipment, express or implied, arising by operation of law, course of dealing, usage of trade or otherwise, including but not limited to the implied warranties of merchantability and fitness for a particular purpose.**