

Tension or Tensionless Winding with Manual Transfer

Conair MTC Series Coilers are available with a servo drive for tensionless winding, or an AC torque drive for tension winding. They can be provided in single or dual spindle configurations.

The MTC Series are best suited for applications where slower line rates are common and flexible or semi-rigid tubing and profiles need to be coiled.



Model MTC
(Shown with single spool in MedLine® white.)

Cost-effective Precision Coiling

The MTC Series is available in single or dual spindles, with spool diameters of 24, 36 and 48 inches {61, 91, 122 cm} and is designed for line rates up to 200 feet per minute {61 meters/min}. Product diameters can range from 0.085 to 0.500 inch {0.22 to 1.27 cm}.

The MTC is for tension winding of products that require a tight wrap on the spool to stay in place. The unit will self-synchronize to the line rate (does not require a dancer). The control is basic push button with potentiometer for tension adjustment. The traverse is mechanical with side-to-side limits and adjustable pitch settings.

The MTC-S is for tensionless winding of flexible products prone to stretching. The MTC-S incorporates sophisticated servo drives for the spindles and traverse, for precise control of the tension to eliminate product distortion. Available with a mechanical dancer with adjustable counter weight, or an optional non-contact sonar loop control. The MTC-S comes with a touch screen HMI with set up screens, recipe storage and alarm screen.

▶ Best accuracy with servo control

Spindle rotation, traverse motion and spindle speed are all servo driven. This provides the perfect in speed and positioning control for error-free high repeatability and optimum product tension throughout the entire high speed coiling and cut/transfer process. Finished spools require no dial-in for product changeover.

▶ Distortion-free product

Optimum tension is achieved by an advanced control algorithm that calculates each successive wrap diameter to adjust coil speed and traverse motion relative to the tube size and puller speed. This allows the sonic loop control to perform as a fine-trim device and ensures accurate, distortion-free, error-free lay of each wrap. The following circuit allows automated ramp-up of the winder synchronously with the line at startup.

▶ Recipes cut operator variability/error

Every operating parameter can be saved within a recipe for repeatable production consistency.

▶ Options to meet your needs

- Set of collapsible coils
- Modifications for use of customer coils
- Additional product tips
- 230V/3 phase/60 Hz voltage
- Left-to-right operation
- Custom paint
- Manufactured to meet medical requirements
- Full safety enclosure

Specifications

Note: This line drawing shows a dual-servo unit.

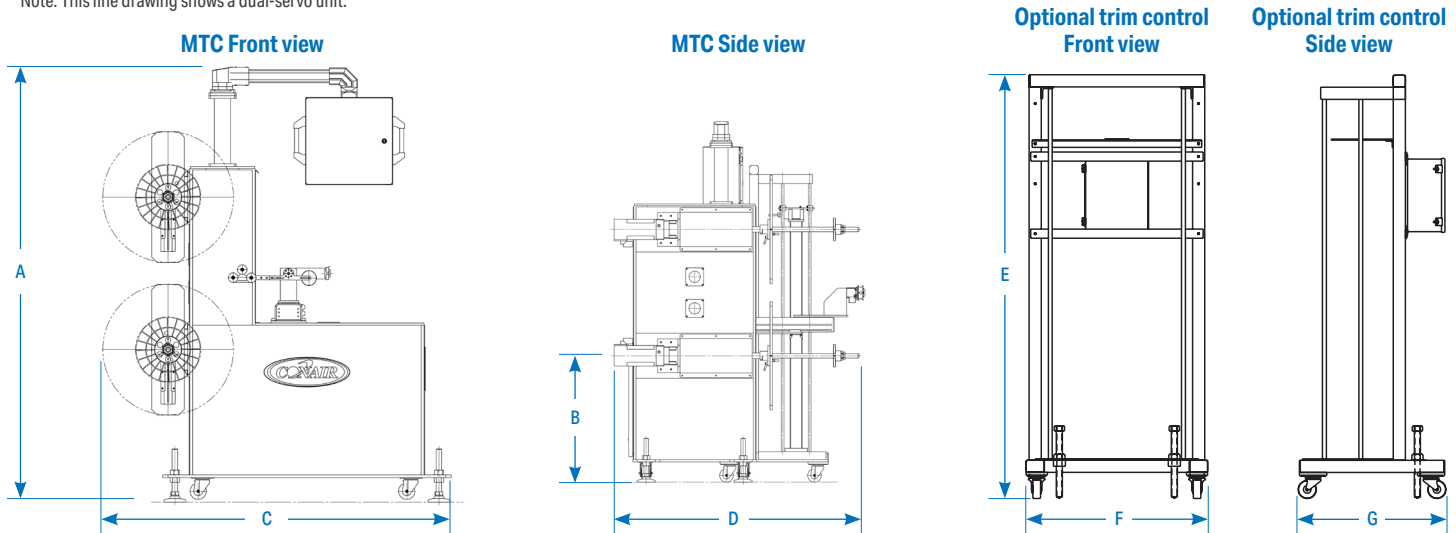

Models	MTC-24 / MTC-24S	MTC-36 / MTC-36S	MTC-48* / MTC-48S†
Performance characteristics			
Product range tube diameter inches {mm}	Typical 0.085 to 0.5 {2.16 to 12.7} / Optional 0.02 {0.5} and up to 1.0 {25.4}		
Coil type	Customer spools (subject to review of drawing). Optional - set of collapsible spools		
Coil drive	MTC = torque motor. MTC-S = Servo Drive		
Coil size OD inches {mm}	24 {610}	36 {914}	48 {1219}
Coil width inches {mm}	12 {305} standard		
Coil width option inches {mm}	18 {457} optional		
Traverse	MTC = mechanical traverse MTC-S = Servo ball screw		
Line rate	Up to 200 FPM {61m/min} depending on operator		
Line direction	Right-to-left standard. Left-to-right optional.		
Controls	MTC = push buttons with speed potentiometer. MTC-S = touch screen HMI>		
Frame	Heavy-duty welded steel with casters and leveling screws		
Dimensions inches {mm}			
A - Overall height	66.3 {1684.0}	86.0 {2184.4}	Contact Conair
B - Height to spindle centerline	40.0 {1016.0}	41.2 {1046.5}	Contact Conair
C - Overall length	72 {1828.8}	99.7 {2532.4}	Contact Conair
D - Overall width	54 {1371.6}	83.1 {2110.7}	Contact Conair
Approximate weight lb {kg}			
Shipping	2200 {998}	4400 {1996}	Contact Conair
Voltage Full load amps*			
Consult Conair			

Trim Control (optional)	
Dancer type (MTC-S)	Non-contact ultrasonic for tube diameters 0.085 to 0.5 in. {2.16 to 12.7 mm} Ultra-lightweight roller contact ultrasonic for tube diameters 0.02 to 0.085 in. {0.5 to 2.16 mm}
Dimensions inches {mm}	
E - Overall height	70.0 {1778}
F - Overall length	30.0 {762}
G - Overall width	24.4 {620}
Approximate weight lb {kg}	
Shipping	500 {226.8}
Voltage Full load amps*	
460V/3 phase/60 Hz	
Consult Conair	

Specification Notes

* FLA data for reference purposes only. Does not include any options or accessories on equipment. For full FLA detail for power circuit design of specific machines and systems, refer to the electrical diagrams the equipment order and the nameplate applied to the machine.

† Specifications for MTC-48 and MTC-48S models vary based on order. Contact Conair for more information.

Specifications may change without notice. Consult with a Conair representative for the most current information.

