

High Volume Extra Duty Size Reduction

Large quantities of bulk plastic scrap are quickly size-reduced with the heavy-duty FLEX Series Shredders from Conair. Designed specifically for size-reducing high volumes of plastic scrap, the FLEX Series includes features that allow Conair to customize the FLEX to meet your specific shredding needs. With rotor diameters of 15 or 20 inches, widths up to 105 inches and drive motors from 40 to 300 Hp. The FLEX Series can be readily matched to the challenges of hard, soft, flexible plastic scrap in bundles, dumped from gaylords or fed loosely.

Controlled feeding is provided by an automatic hydraulic ram that pushes scrap into a rotating row of rugged knives welded (standard) or bolted (optional) into machined pockets of the solid steel rotor. Once started, operation is fully automatic.



FLEX Model 2054
with optional
wide-open access

Flexible Shredder Design for Maximum Efficiency

The FLEX Series can be provided with Conair's wide-open design that allows easy opening of the entire shredder body for full access to the rotor and ram from inside the shredder. Maintenance is fast, safe and thorough.

Standard dagger-cut knives offer four cutting edges that can be renewed by simply unbolting and indexing each four-edged knife to reveal a fresh cutting edge. Each knife slices against notched bed knives for fast, efficient, size reduction.

Optional trapezoid "trap cut" blades provide two cutting edges and may be selected for even tougher shredding applications.

Final particle size is established by forcing the shredded scrap through a broad choice of reinforced screens. Screens are provided in holes sizes from a coarse 4 inch {102 mm} down to fine 3/8 inch {10 mm} diameter.

► Long-life, high-impact rotor takes the abuse

The drop-forged, single-shaft, solid steel rotor is 4140 high alloy steel, heat treated for high tensile strength with a lifetime limited warranty. Oversized outboard pillow block bearings with split housings provide long life and easy shaft removal.

► Extra-long service from indexable 4-way blades

Dagger-cut design penetrates and efficiently cuts through plastic scrap and can be easily rotated to employ a fresh tip.

► Self-protecting drive train

The over-torque limiting clutch assembly eliminates shredding resistance from being transferred to the gearbox, providing smoother operation and extended life of all drive train components.

► Controlled shredding that requires no monitoring

Automatic rotor and ram control is provided via a PLC control with a touch screen interfaces. All models include an auto-reverse rotor shaft, to quickly and automatically recover from rotor jams.

► Wide Open Access for walk-in service

A patented sliding, horizontal body separation allows easy access to knives, rotor, and all material contact surfaces for easy maintenance and cleaning.

Features

- **Solid steel single-piece forged rotors** maximize durability and are heat treated for strength
- **Self-cleaning non-contaminating rotor** seals ensure bearings last significantly longer
- **Oversized spherical bearings** limit drift and handle even heavy regrind
- **Auto-reverse rotor operation** quickly recovers your process in the event of jams
- **Straight-walled hopper** minimizes chance of materials bridging or compacting
- **Service access doors** (with removable rear compartment) provide easy access for maintenance
- **Indexable dagger-cutting blades (4-way)** require little sharpening or maintenance to keep cutting efficient
- **Over-torque limiting clutch** provides automatic shutdown to prevent damage in the event of prolonged clutch slippage
- **Heavy duty construction cutting chamber** maximizes dimensional stability to ensure precision, strength, and durability
- **Ultra-duty gear boxes** are directly coupled to regulate rotor speed

Dagger-Cut Blades

The dagger-cut blade is used for granulating hard plastic with minimal strain to the blade or the rotor. Four cutting surfaces are available on each dagger-cut blade, indexable with only a wrench. Each blade holder is welded into the surface of the machined rotor surface for superior reinforcement.



One Piece Rotor

Conair is one of the very few suppliers that offer a one piece forged/machined rotor that eliminates the chance of rotor breakage or separation. The brute force nature of shredding requires maximum rotor strength and the heat treated high alloy steel in the FLEX series assures long operational life.



Easy Screen Access

Dual access doors provide easy, safety interlocked access to the FLEX Series screen, offered in a range of hole sizes from 3/8 through 4 inches. The doors are located above the scrap exit chute, so quick inspections and cleaning can take place without moving the take-away conveyor or secondary granulator.

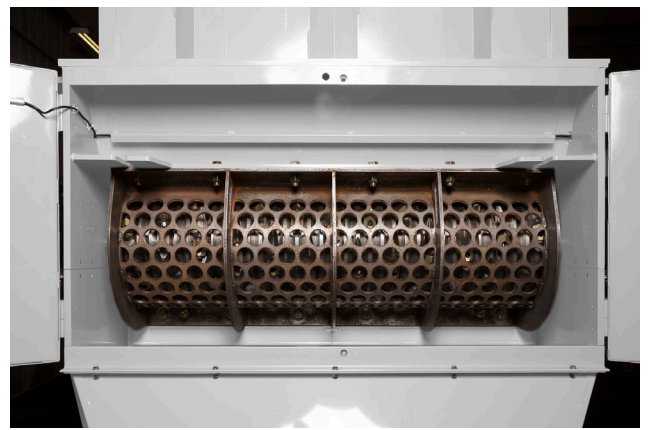

Options

- **Take-away conveyors**
- **Elevating legs**
- **Custom feed hoppers**
- **Wide open chamber access** for fast, safe cleaning and maintenance
- **Evacuation blower/vacuum system**
- **Interlocking controls** for both feed and take-away conveyors

- **Trap-cut knives**
- **Extra row of blades**
- **Bolt-in tool holders**
- **High-powered rotor motors** available from 50 to 300 Hp {37 to 224 kW}
- **Variety of screen hole sizes** available from 3/8 to 4 inches {10 to 102 mm}

Trap-Cut Knives

The trapezoid-shaped Trap-Cut knives offer two cutting edges that are easily renewed by simply unbolting and rotating each knife to reveal a fresh cutting edge. Each blade holder is embedded and bolted below the surface of the machined rotor surface for superior reinforcement. Blade holders may be easily unbolted and replaced if ever required.

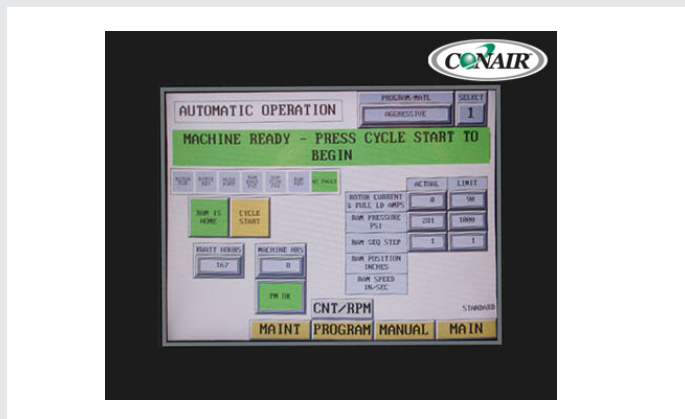
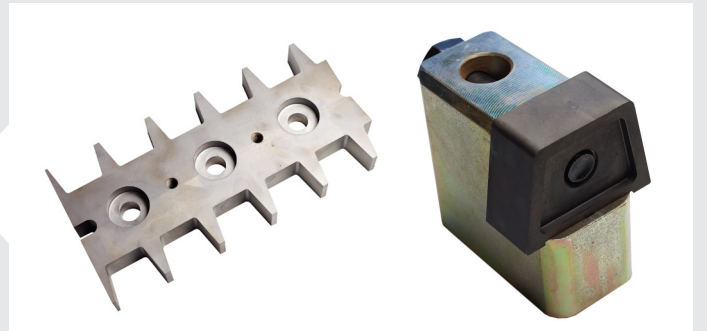

Auto-Shred Operation Option

With Conair's Auto-Shred control option, fully automatic operation is provided for true "load it and forget it" operation. Up to six fully automatic control programs may be easily initiated via the full color touch screen.

Once started, Auto-Shred guides the motion of the ram for smooth, highly efficient shredding with minimal rotor drive spikes. In the event of a jam, Auto-Shred automatically reverses the rotor to reduce damage.

In addition, Auto-Shred provides fast return-to-home position of the ram for fast recovery and restart of shredding.

Wide Open Access

Each FLEX shredder model has the option of the Wide Open Access configuration. With this option, awkward top entry into the shredding zone is eliminated by splitting the hopper and exposing all cutting and ramming components to walk-in entry. Proper maintenance is encouraged, personnel safety is enhanced, and shredder cleaning has never been easier.

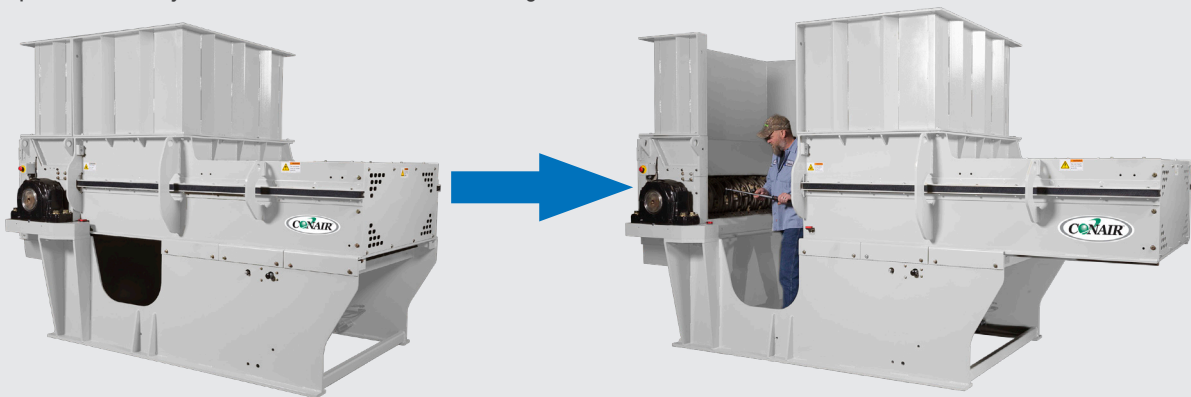

Specifications

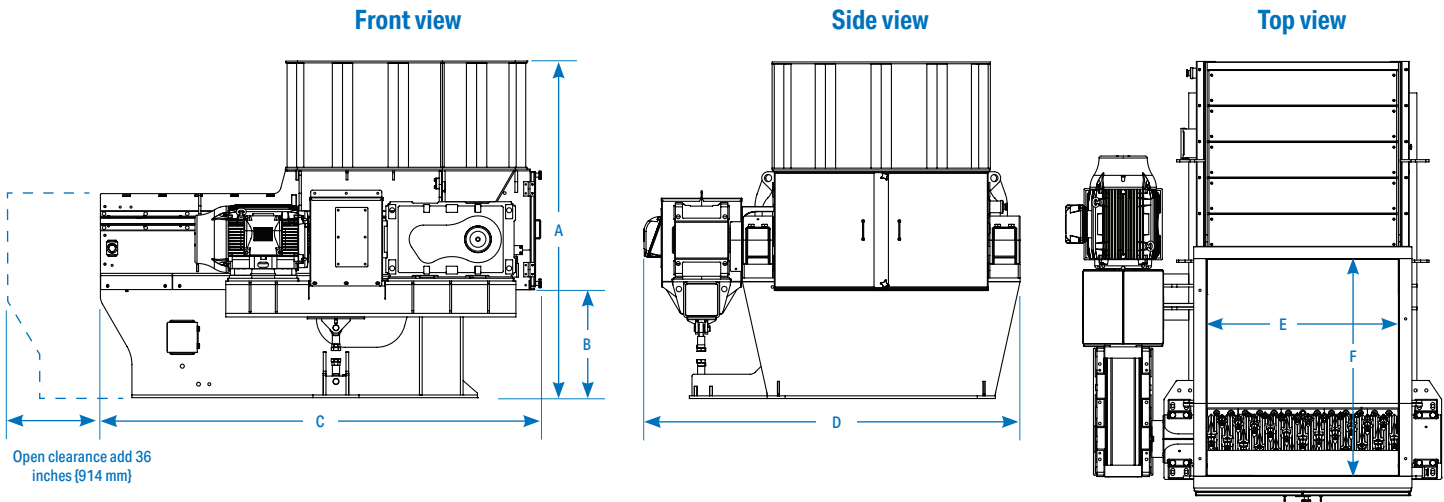

Models	FLEX 1530	FLEX 1542	FLEX 1554	FLEX 1566	FLEX 2054	FLEX 2066	FLEX 2078
Performance characteristics							
Cutting chamber opening inches {mm}	30 x 50 {762 x 1270}	42 x 50 {1067 x 1270}	54 x 60 {1372 x 1524}	66 x 85 {1676 x 2159}	54 x 65 {1372 x 1651}	66 x 90 {1676 x 2286}	15 {381}
Rotor speed rpm	110 - 130						
Rotor diameter inches {mm}	15 {381}					20 {508}	
Motor range Hp {kW}	40-75 {30-56}	40-100 {30-75}	75-200 {56-149}	100-250 {75-186}	100-250 {75-186}	125-300 {93-224}	150-300 {112-224}
Ram height inches {mm}	11 {279}					16 {406}	
Ram hydraulic motor Hp {kW}	7.5 {5.6}						
Screen hole diameter inches {mm}	3/8 - 4 {9 - 102}						
Screen type	standard round or square options available						
Dimensions standard configuration inches {mm}							
A - Overall height (to infeed)	93.5 {2375}						
B - Height of discharge	30.0 {762}						
C - Total length	103.0 {2616}		123.0 {3124}	173.0 {4394}	133.0 {3378}	183.0 {4648}	213.0 {5410}
Length when open	139 {3530}		159 {4039}	209	169	219	249
D - Total width	74.5 {1892}	92.5 {2350}	104.5 {2654}	116.5 {2959}	108.5 {2756}	120.5 {3061}	131.5 {3340}
E - Feed hopper opening width	29.3 {744}	41.1 {1044}	53.1 {1349}	65.1 {1654}	53.1 {1349}	65.1 {1654}	76.1 {1933}
F - Feed hopper opening length	50.0 {1270}		60.0 {1524}	85.0 {2159}	65.0 {1651}	90.0 {2286}	105.0 {2667}
Approximate installed weight lb {kg}	8000 {3629}	10000 {4536}	14000 {6350}	17000 {7711}	15000 {6804}	18000 {8165}	22000 {9979}
Voltages Full load amps							
460 V/3 phase/60 hz	Consult Conair						

Specification Notes

Consult factory for throughput specifications.
 Specifications may change without notice. Consult with a Conair representative for the most current information.