

USER GUIDE
UGD065-1120

dX Carousel Plus™ Dryer

dX Models 15, 25, 50, 75, 100, 150 and 200
with DC-C PLUS, or DC-C Premium Controls



Please record your equipment's model and serial number(s) and the date you received it in the spaces provided.

It's a good idea to record the model and serial number(s) of your equipment and the date you received it in the User Guide. Our service department uses this information, along with the manual number, to provide help for the specific equipment you installed.

Please keep this User Guide and all manuals, engineering prints, and parts lists together for documentation of your equipment.

Date:

Manual Number: UGD065-1120

Serial Number(s):

Model Number(s):

Display Menu Version:

Control Version:

DISCLAIMER: Neither Conair nor its employees shall be liable for errors contained in this User Guide or for incidental, consequential damages in connection with the furnishing, performance or use of this information. Conair makes no warranty of any kind with regard to this information, including, but not limited to, the implied warranties of merchantability and fitness for a particular purpose.

Table of Contents

1 - 1 Introduction

Purpose of the User Guide	1-2
How the Guide Is Organized.....	1-2
User Responsibility	1-2
Read This Important Safety Information	1-3
How to Use the Lockout Device	1-4

2 - 1 Description

What is the dX Carousel Plus Dryer?.....	2-2
Optional Self-Loading dX.....	2-2
Typical Applications.....	2-2
How It Works	2-4
How Conveying Works.....	2-5
Specifications: dX Carousel Plus Dryers.....	2-6
Specifications: dX 150 & 200 Carousel Plus Dryers	2-7
dX Carousel Plus Dryer Options	2-8

3 - 1 Installation

Unpacking the Boxes.....	3-2
Preparing for Installation	3-3
Installing the dX	3-4
Connecting Conveying Lines.....	3-5
Connecting the Demand Sensor	3-5
Mounting a Loader on the Hopper.....	3-6
Connecting Material Lines for Self-Loading (optional)	3-6
Connecting the Main Power.....	3-7
Connecting Compressed Air for Self-Loading (optional).....	3-7
Checking for Proper Air Flow	3-8
Connecting the Aftercooler	3-9
Testing the Installation.....	3-10
Using Communications (optional)	3-11

4 a - 1 Operation - DC-C Plus Control

The dX Dryer: Control Panel DC-C Plus	4a-2
Control Function Flow Charts.....	4a-2
Control Function Descriptions.....	4a-8
To Start Drying	4a-17
To Stop Drying.....	4a-18
Using the Loading Function on the Hopper Loader (optional).....	4a-18
Machine Loader Conveying	4a-19
How to Log In.....	4a-20
Using the Auto Timer	4a-21
Setting High Setpoint Limits	4a-22
Using Dewpoint Control.....	4a-22
Using the Energy Use Monitor.....	4a-23
Using the Setback Feature.....	4a-23
Setback Feature Guidelines	4a-24
Automatic Cleaning Cycle.....	4a-25

4 b - 1 Operation - DC-C Premium Control

The dX Dryer: Control Panel DC-C Premium.....	4b-2
Control Function Flow Charts.....	4b-2
Control Function Descriptions.....	4b-8
To Start Drying	4b-17
To Stop Drying.....	4b-18
Using the Loading Function on the Hopper Loader (optional).....	4b-18
Machine Loader Conveying	4b-19
How to Log In.....	4b-20
Using the Auto Timer	4b-21
Setting High Setpoint Limits	4b-22
Using Dewpoint Control.....	4b-22
Using the Energy Use Monitor.....	4b-23
Using the Setback Feature.....	4b-23

Setback Feature Guidelines	4b-24
Material Recipe Screens.....	4b-25
Automatic Cleaning Cycle.....	4b-26

5 - 1 Maintenance

Preventative Maintenance Schedule	5-2
Checking the Dewpoint	5-3
Cleaning the Hopper.....	5-3
Clean the Process Filter.....	5-4
Cleaning the Regeneration Filters	5-5
Cleaning the Conveying Filter	5-6
Cleaning the Vacuum Receiver	5-7
Screen Filter Cleaning (optional).....	5-8
Cleaning the Compressed Air Filter (optional).....	5-9
Cleaning the Optional Water-to-Air Aftercooler Coils	5-9
Cleaning the Precooler Coils.....	5-10
Inspecting Hoses and Gaskets.....	5-10
Cleaning and Servicing the Desiccant Rotor.....	5-11

6 - 1 Troubleshooting

Before Beginning.....	6-2
A Few Words of Caution.....	6-3
Identifying the Cause of a Problem	6-3
Shutdown Alarms	6-4
Passive Alarms	6-8
Poor Material Drying Troubleshooting	6-15
Replacing Fuses.....	6-20
Checking or Replacing Temperature Sensors	6-20
Replacing the Heaters	6-22
Replacing the Desiccant Wheel Assembly	6-24
Inspecting/Cleaning the Air-to-Air Aftercooler	6-25

A	Appendix	
	Customer Service Information	A-1
	Warranty Information.....	A-2
B	Appendix	
	Cleaning the Precooler Coils (if Equipped).....	B-1
C	Appendix	
	Modbus Communications.....	C-1
	Modbus Address List.....	C-3
D	Appendix	
	Changing the IP Address on a DC-C Dryer	D-1
	Reset VNC Connection.....	D-4
E	Appendix	
	Virtual Network Computing.....	E-1

Introduction

Purpose of the User Guide	1-2
How the Guide Is Organized	1-2
User Responsibility	1-2
Read This Important Safety Information	1-3
How to Use the Lockout Device	1-4

Purpose of the User Guide

This User Guide describes the Conair dX Carousel Plus™ Series Dryers and explains step-by-step how to install and operate this equipment.

Before installing this product, please take a few moments to read the User Guide and review the diagrams and safety information in the instruction packet. You also should review manuals covering associated equipment in your system. This review won't take long, and it could save you valuable installation and operating time later.

How the Guide is Organized

Symbols have been used to help organize the User Guide and call your attention to important information regarding safe installation and operation.



Symbols within triangles warn of conditions that could be hazardous to users or could damage equipment. Read and take precautions before proceeding.



Numbers indicate tasks or steps to be performed by the user.



A diamond indicates the equipment's response to an action performed by the user or a situation.



An open box marks items in a checklist.



A circle marks items in a list.



Indicates a tip. A tip is used to provide you with a suggestion that will help you with the maintenance and the operation of this equipment.



Indicates a note. A note is used to provide additional information about the steps you are following throughout the manual.

User Responsibility

You must be familiar with all safety procedures concerning installation, operation, and maintenance of this equipment. Responsible safety procedures include:

- Thorough view of this User Guide, paying particular attention to hazard warnings, appendices, and related diagrams.
- Thorough review of the equipment itself, with careful attention to voltage sources, intended use, and warning labels.
- Thorough review of instruction manuals for associated equipment.
- Step-by-step adherence to instructions outlined in this User Guide.

Read This Important Safety Information

We design equipment with the user's safety in mind. You can avoid the potential hazards identified on this machine by following the procedures outlined below and elsewhere in the User Guide.



WARNING: Improper installation, operation, or servicing may result in equipment damage or personal injury.



This equipment should be installed, adjusted, and serviced by qualified technical personnel who are familiar with the construction, operation, and potential hazards of this type of machine.

All wiring, disconnects, and fuses should be installed by qualified electrical technicians in accordance with electrical codes in your region. Always maintain a safe ground. Do not operate the equipment at power levels other than what is specified on the machine serial tag and data plate.



WARNING: Voltage hazard



This equipment is powered by three-phase alternating current, as specified on the machine serial tag and data plate.

A properly sized conductive ground wire from the incoming power supply must be connected to the chassis ground terminal inside the electrical enclosure. Improper grounding can result in severe personal injury and erratic machine operation.

Always disconnect and lock out the incoming main power source before opening the electrical enclosure or performing non-standard operating procedures, such as routine maintenance. Only qualified personnel should perform troubleshooting procedures that require access to the electrical enclosure while power is on.



CAUTION: Hot Surfaces

Always protect yourself from hot surfaces inside the dryer and hopper. Also exercise caution around exterior surfaces that may become hot during use. These include the hopper door frame, the exterior of an uninsulated hopper, the return air hose and the dryer's process filter housing and moisture exhaust outlet.



WARNING: Do not place aerosol, compressed gas or flammable materials on or near this equipment.

The hot temperatures associated with the drying process may cause aerosols or other flammable materials placed on the dryer or hopper to explode.

How to Use the Lockout Device

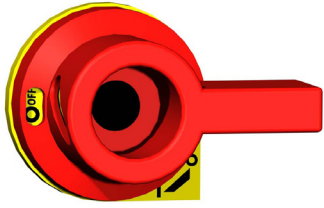

CAUTION: Before performing maintenance or repairs on this product, you should disconnect and lockout electrical power sources to prevent injury from unexpected energization or start-up. A lockable device has been provided to isolate this product from potentially hazardous electricity.

Lockout is the preferred method of isolating machines or equipment from energy sources. Your Conair product is equipped with the lockout device pictured below. To use the lockout device:



- 1 Stop or turn off the equipment.**
- 2 Isolate the equipment from the electric power.** Turn the rotary disconnect switch to the OFF, or "O" position.
- 3 Secure the device with an assigned lock or tag.** Insert a lock or tag in the holes to prevent movement.
- 4 The equipment is now locked out.**



WARNING: Before removing lockout devices and returning switches to the ON position, make sure that all personnel are clear of the machine, tools have been removed and all safety guards reinstalled.



NOTE: The lockout device supplied on your dryer may not appear identical to the one shown here. Illustration is for reference only.

Description

What is the dX Carousel Plus Dryer? 2-2

Optional Self-Loading dX..... 2-2

Typical Applications 2-2

How It Works 2-4

How Conveying Works 2-5

Specifications: dX Carousel Plus Dryers..... 2-6

Specifications: dX 150 & 200 Carousel Plus Dryers.... 2-7

dX Carousel Plus Dryer Options 2-8

What is the dX Carousel Plus Dryer?

The dX Carousel Plus Dryer is a self-contained, mobile unit designed to dry plastic resin and convey it with dehumidified air directly to a processing machine. This mobile unit contains:

- A mobile dehumidifying dryer
- Drying hopper with a material distribution box
- Conveying blower and filter (optional)
- Direct feed machine loader with a demand sensor
- Hopper loader (with self-loading option)
- Quick disconnect conveying hoses

The dryer produces hot, low dewpoint air that removes moisture from hygroscopic plastics. When the conveying function is turned on, the conveying blower conveys the dried resin to the machine loader mounted on the processing machine. The demand sensor on the machine loader viewing chamber allows you to convey just enough material to satisfy the shot size required for your process.

Optional Self-Loading dX

The self-loading option on the dX Carousel Plus Dryer allows the conveying blower to convey new material from the material source into the drying hopper on the dX. This option is in addition to the standard conveying capability on an dX, which is conveying material to the machine from the drying hopper. This option allows the dX to be a totally self-contained system with a common control.

Typical Applications

The dX Carousel Plus Dryer was designed for drying and conveying beside the press. But it can also be used to pre-dry material in one location, and then transport the dried material to another location for conveying into the processing machine.



Typical Applications (continued)

The dX Carousel Plus Dryer can be used successfully in applications that require:

- A contamination-free drying environment
- Drying temperatures within the ranges shown in the following table:

Model	Drying Temperature Range
Low temperature (with precooler)	100° - 150°F {38° - 66°C}
Standard High heat (with aftercooler)	150° - 375°F {66° - 191°C}
Low-high (with aftercooler & precooler)	100° - 375°F {38° - 191°C}

- Throughput rates of 15 to 100 lbs {6.8 to 37.3} per hour (some materials can be run at a higher rate).
- Dewpoints of -40°F {-40°C}.
- Conveying material at distances up to, but not more than, 8 feet {2.4 m} vertically and 6 feet {1.8 m} horizontally. (The long haul option allows conveying material at distances up to, but not more than, 15 feet {4.6 m} vertically and 50 feet {15.2 m} horizontally.)

Use the aftercooler when:

- Throughput rates are less than 50% of the dryer's rated capacity.
- You are pre-drying material at temperatures over 150°F {66°C}.

 **NOTE:** When ambient temperature is above 110°F {43°C} or drying above 375°F {191°C}, an optional water-cooled aftercooler is required.

How It Works

■ The Process (Drying) Cycle

The process blower pulls moist air from the top of the drying hopper. The air passes through the process filter and aftercooler, then into the desiccant wheel, where moisture is removed. The now dry air moves through the optional precooler (if installed) and process heater, where it is heated to the drying temperature selected by the operator. The hot, dry air is delivered to the hopper where a spreader cone evenly distributes the air through the material.

■ The Regeneration Cycle

The regeneration blower pulls air through the regeneration filter into the dryer's regeneration heater. The air is heated to 350° F {177° C} before it is pushed into the "wet" section of the wheel. The hot air purges moisture from the desiccant. The moist air is blown out the exhaust at the back of the dryer.

□ The Cooling Cycle

Regenerated desiccant must be cooled before it rotates back into the process cycle. The process blower pushes a small amount of air through the cooling section of the desiccant wheel. The cooling air then passes through the aftercooler and repeats the circuit.

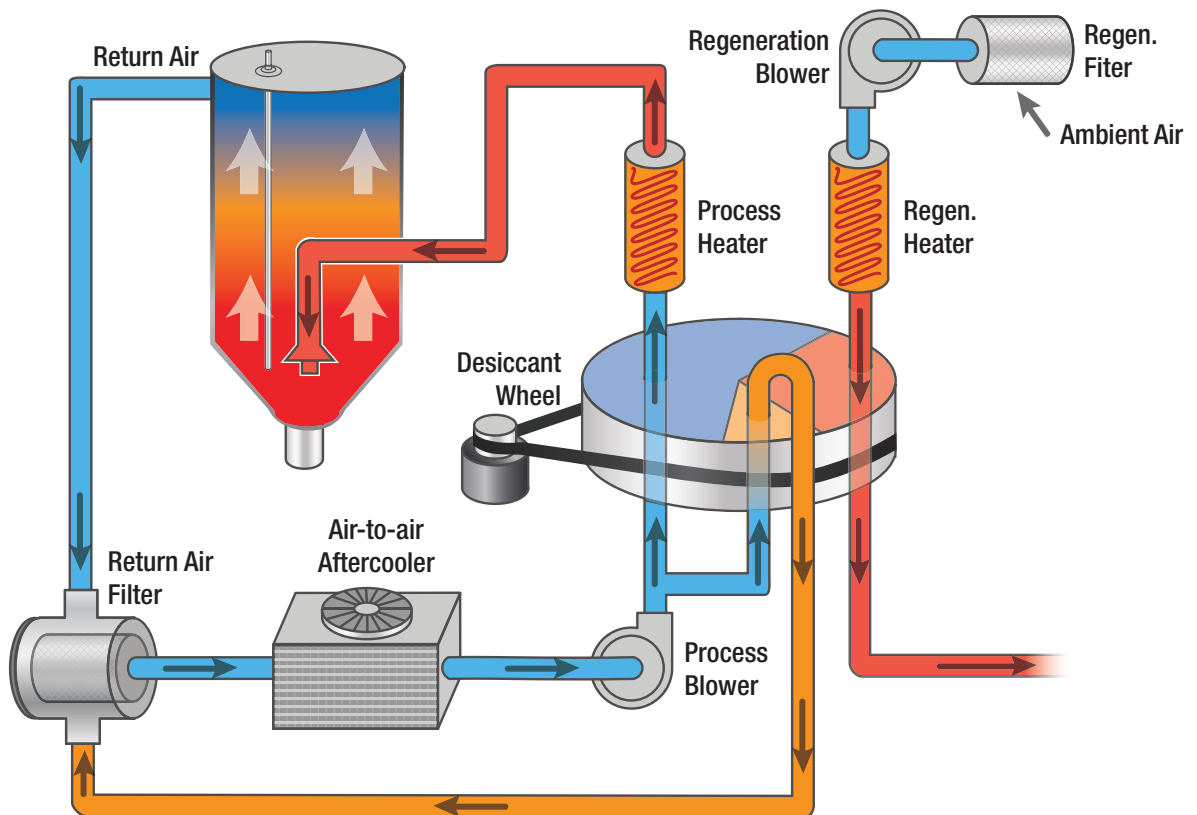

How Conveying Works

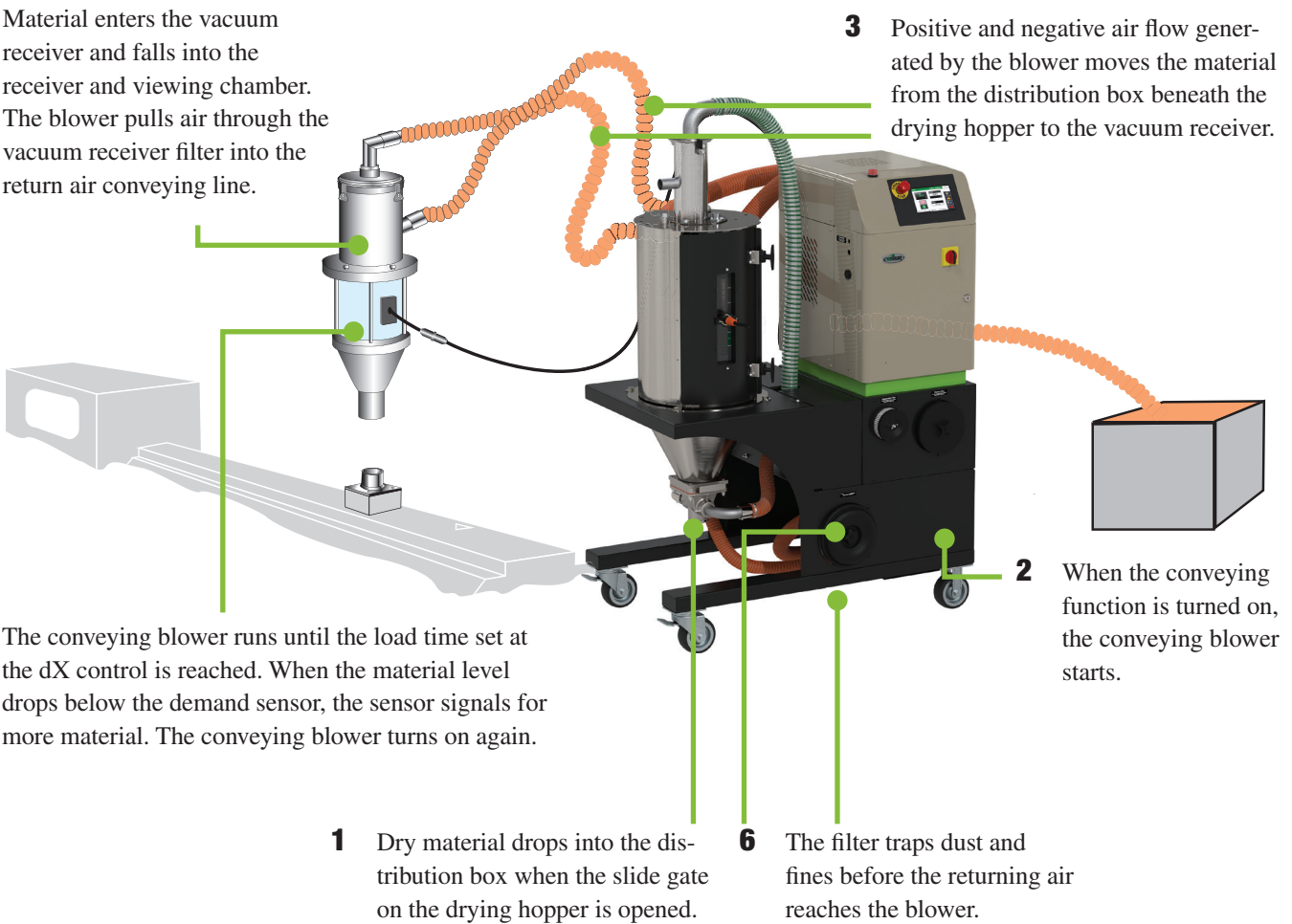
- 
- The diagram illustrates a conveying system. On the left, a grey distribution box is connected to a black drying hopper. A silver vacuum receiver is positioned above the hopper. A grey conveying blower is connected to the hopper and a grey vacuum receiver filter. A grey return air conveying line connects the filter to the blower. A grey distribution box is connected to the hopper. A grey conveying blower is connected to the hopper and a grey vacuum receiver filter. A grey return air conveying line connects the filter to the blower. A grey distribution box is connected to the hopper. A grey conveying blower is connected to the hopper and a grey vacuum receiver filter. A grey return air conveying line connects the filter to the blower.
- 1** Dry material drops into the distribution box when the slide gate on the drying hopper is opened.
 - 2** When the conveying function is turned on, the conveying blower starts.
 - 3** Positive and negative air flow generated by the blower moves the material from the distribution box beneath the drying hopper to the vacuum receiver.
 - 4** Material enters the vacuum receiver and falls into the receiver and viewing chamber. The blower pulls air through the vacuum receiver filter into the return air conveying line.
 - 5** The conveying blower runs until the load time set at the dX control is reached. When the material level drops below the demand sensor, the sensor signals for more material. The conveying blower turns on again.
 - 6** The filter traps dust and fines before the returning air reaches the blower.

Specifications: dX Carousel Plus Dryers

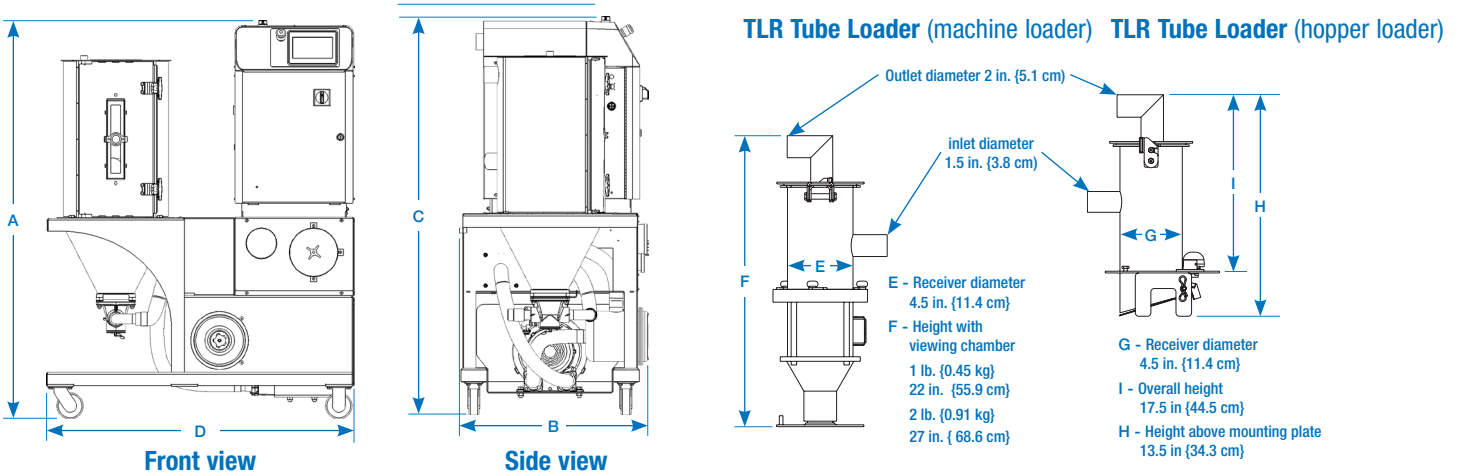

Models	dX15	dX25	dX50	dX75	dX100
Standard hopper models	RWH14-2	RWH14-3	RWH18-6	RWH24-9	RWH24-12
Optional hopper models	N/A	RWH14-4	N/A	RWH24-12	RWH24-18
Performance characteristics (with full hopper)					
Drying temperature	150° - 375°F {66 - 191°C} with options				
Dewpoint	-40°F {-40°C}				
Standard conveying distance	8 ft {2.44 m} vertical; 6 ft {1.83 m} horizontal				
Long distance conveying option	15 ft {4.57 m} vertical; 50 ft {15.24 m} horizontal				
Dimensions inches {cm}					
A - Height top of conveying pipe	73.4 {186.5}		77.2 {196.1}		
B - Overall width	32.5 {82.5}		37.1 {94.2}		
C - Height to top of hopper (standard)	53.7 {136.4}	67 {170.2}	88.1 {223.7}	82.5 {209.6}	90.5 {229.8}
C - Height to top of hopper (optional)	N/A	74.7 {189.7}	N/A	90.5 {229.8}	114.4 {290.6}
D - Depth	47.1 {119.5}		67.2 {170.8}		
Drying outlet/inlet tube size OD	2.5 {6.35}				
Approximate weight lbs {kg}					
Standard dryer installed	550 {250}	600 {272}	672 {305}	756 {353}	840 {381}
Standard dryer shipping	700 {318}	790 {358}	885 {401}	913 {414}	1064 {483}
Voltage - Full load amps†† (standard/long conveying distance)					
208 V/3 phase/60 Hz	18.2 / 22.2		22.6 / 26.6		N/A
230 V/3 phase/60 Hz	16.4 / 20.0		20.5 / 24.1		27.5 / 31.1
400 V/3 phase/50 Hz*	9.6 / 11.6		12.0 / 14.0		15.3 / 17.3
460 V/3 phase/60 Hz	8.1 / 9.9		10.1 / 11.9		13.6 / 15.4
575 V/3 phase/60 Hz	6.4 / 8.0		8.0 / 9.6		10.9 / 12.4
Total kilowatts† kW (std./long)	4.1/5.0		5.3/6.2		6.1/7.0
Water-cooled requirements (for optional aftercooler or precooler)†‡§					
Recommended temperature**	45° - 85°F {7.2° - 29.4°C}				
Water flow gal./min. {liters/min.}	1 {4.6}		2 {9.1}		
Water connections NPT	3/4 inch NPT				

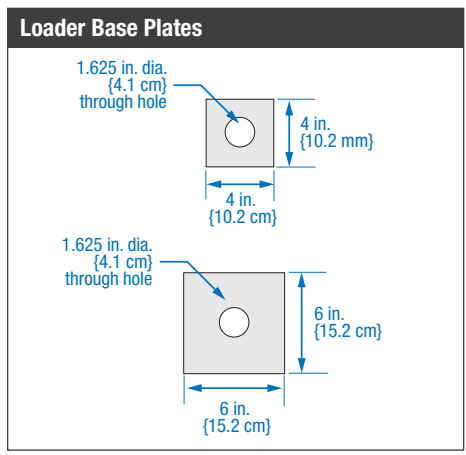

Application Notes

All dryers are supplied with an aftercooler as standard. The aftercooler reduces the temperature of the return air from the drying hopper, improving the efficiency of the desiccant. If using the water-cooled aftercooler option, the aftercooler must be connected to supply water with the proper flow rate and temperature.

When to use additional filtration
The standard return air cartridge filter is sized for the airflow of each dryer model and is suited for most applications. You should consider adding an optional dust collector and/or volatile trap if:

- The material contains excessive fines. An additional dust collector or cyclone will extend time between filter cleaning.
- The material produces volatiles during drying which condense into a waxy or oily residue. A volatile trap will help to protect the desiccant.

Specification Notes

* Dryers running at 50 Hz will have 17% less airflow, and a 17% reduction in material throughput.

† Total kW listed at a process setpoint of 250°F {121°C} and a regeneration temperature of 350°F {177°C}.

‡ When drying below 150°F {66°C} a precooler is required.

§ When ambient temperature is above 110°F {43°C} and drying above 375°F {191°C} a water-cooled aftercooler is required.

** Temperatures above or below the recommended levels may affect dryer performance. Tower, chiller, or municipal water sources can be used.

†† FLA data for reference purposes only. Does not include any options or accessories on equipment. For full FLA detail for power circuit design of specific machines and systems, refer to the electrical diagrams of the equipment order and the nameplate applied to the machine.

Specifications may change without notice. Consult a Conair representative for the most current information.

Specifications: dX 150 & 200 Carousel Plus Dryers

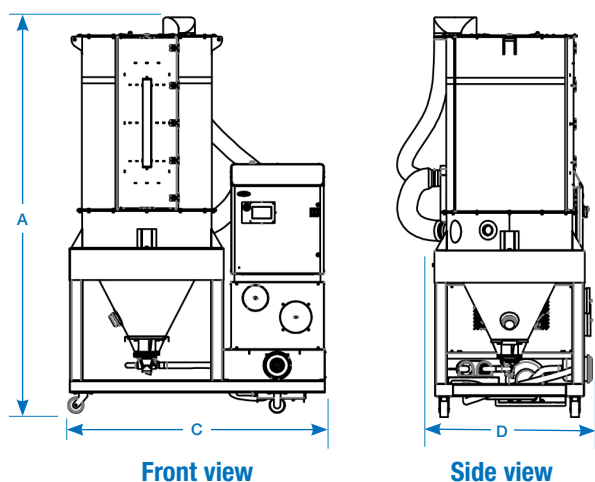

TLR Tube Loader (machine loader) DuraLoad DL12 (hopper loader)

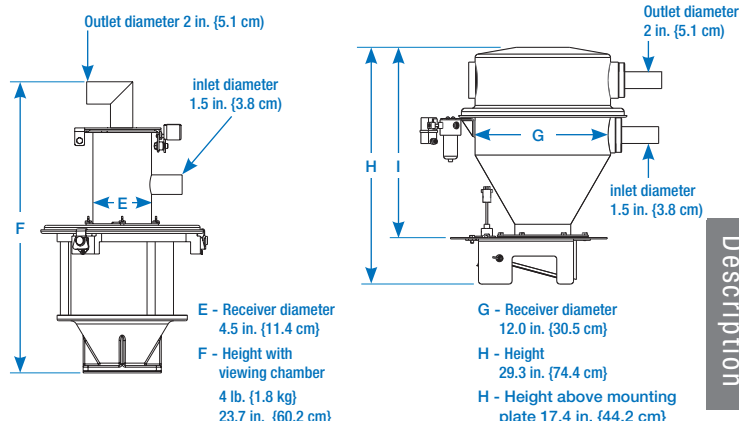

Description 2

Models	dX150	dX200
Standard hopper models	CH33-21	CH39-35
Optional hopper models	CH33-28	CH39-42
Performance characteristics (with full hopper)		
Drying temperature	150° - 375°F {66° - 191°C} with options	
Dewpoint	-40°F {-40°C}	
Standard conveying distance	8 ft {2.44 m} vertical; 6 ft {1.83 m} horizontal	
Long distance conveying option	15 ft {4.57 m} vertical; 50 ft {15.24 m} horizontal	
Dimensions inches {cm}		
A - Height to top of hopper (standard)	123.3 {313.2}	129 {327.6}
A - Height to top of hopper (optional)	137.4 {348.9}	139.1 {353.3}
C - Overall width	55 {139.8}	56 {142.2}
D - Depth	75.4 {191.5}	81.4 {206.7}
Drying outlet/inlet tube size OD	5.0 {12.7}	
Approximate weight lbs {kg}		
Standard dryer installed	840 {381}	
Standard dryer shipping	1512 {686}	
Voltage - Full load amps^{††} (standard/long conveying distance)		
230 V/3 phase/60 Hz	45.6 / 48.0	60.6 / 63.0
400 V/3 phase/50 Hz*	26.2 / 27.6	34.8 / 36.2
460 V/3 phase/60 Hz	22.8 / 24.0	30.3 / 31.5
575 V/3 phase/60 Hz	18.3 / 19.3	24.3 / 25.3
Total kilowatts[†] kW (std./long)		
	7.5/8.6	9.4/10.5
Water-cooled requirements (for optional aftercooler or precooler)^{†§}		
Recommended temperature**	45° - 85°F {7.2° - 29.4°C}	
Water flow gal./min. {liters/min.}	1 {4.6}	
Water connections NPT	3/4 inch NPT	

Application Notes

All dryers are supplied with an aftercooler as standard. The aftercooler reduces the temperature of the return air from the drying hopper, improving the efficiency of the desiccant. If using the water-cooled aftercooler option, the aftercooler must be connected to supply water with the proper flow rate and temperature.

When to use additional filtration
The standard return air cartridge filter is sized for the airflow of each dryer model and is suited for most applications. You should consider adding an optional dust collector and/or volatile trap if:

- The material contains excessive fines. An additional dust collector or cyclone will extend time between filter cleaning.
- The material produces volatiles during drying which condense into a waxy or oily residue. A volatile trap will help to protect the desiccant.

Specification Notes

* Dryers running at 50 Hz will have 17% less airflow, and a 17% reduction in material throughput.

† Total kW listed at a process setpoint of 250°F {121°C} and a regeneration temperature of 350°F {177°C}.

‡ When drying below 150°F {66°C} a precooler is required.

§ When ambient temperature is above 110°F {43°C} and drying above 375°F {191°C} a water-cooled aftercooler is required.

**Temperatures above or below the recommended levels may affect dryer performance. Tower, chiller, or municipal water sources can be used.

†† FLA data for reference purposes only. Does not include any options or accessories on equipment. For full FLA detail for power circuit design of specific machines and systems, refer to the electrical diagrams of the equipment order and the nameplate applied to the machine.

Specifications may change without notice. Consult a Conair representative for the most current information.

dX Carousel Plus Dryer Options

 **NOTE:** The optional volatile trap, precooler, and water-cooled aftercooler all require a water connection.

- **Volatile trap** (use only in conjunction with aftercooler) - The volatile trap is recommended when drying materials that produce volatiles that condense into a waxy or oily residue and/or if the material contains excessive fines.
- **Precooler** - The precooler reduces the temperature of air flow after the desiccant wheel and before the process heater, enabling the dryer to control temperatures at low setpoints (100 - 150°F {38 - 66°C}).
- **Filter check** - The filter check sensor will activate a passive alarm when the process filter is clogged or needs replaced.
- **Dryer communications** - Allows the dryer to be networked to industrial control systems. Modbus TCP/IP or Ethernet CIP are available.
- **Water-cooled aftercooler** - For ambient temperature above 110°F {43°C} and drying above 375°F {191°C}.

Installation

Unpacking the Boxes	3-2
Preparing for Installation	3-3
Installing the dX	3-4
Connecting Conveying Lines	3-5
Connecting the Demand Sensor	3-5
Mounting a Loader on the Hopper	3-6
Connecting Material Lines for Self-Loading (optional)	3-6
Connecting the Main Power	3-7
Connecting Compressed Air for Self-Loading (optional).....	3-7
Checking for Proper Air Flow.....	3-8
Connecting the Aftercooler	3-9
Testing the Installation	3-10
Using Communications (optional).....	3-11

Unpacking the Boxes



 ***NOTE:** Depending on the model ordered, the vertical conveying tubes may be shipped detached from the unit.

- 1 Carefully remove the dryer and components from their shipping containers, and set upright.** Note that the dryer is secured to its shipping container with bands and blocking.
- 2 Remove all packing material, protective paper, tape, and plastic.**
- 3 Carefully inspect all components to make sure no damage occurred during shipping.** Check all wire terminal connections, bolts, and any other electrical connections, which may have come loose during shipping.
- 4 Record serial numbers and specifications** in the blanks provided on the back of the User Guide's title page. This information will be helpful if you ever need service or parts.
- 5 You are now ready to begin installation.** Follow the preparation steps on the next page.

Preparing for Installation

The dX Carousel Plus Dryer has been designed for use beside the processing machine. The mobile unit can also be used for pre-drying in a remote location.

1 Make sure the location for the dX provides:

- A grounded power source supplying the correct current for your dryer model.** Check the dryer's serial tag for the correct amps, voltage, phase and cycles. Field wiring should be completed by qualified personnel to the planned location for the dryer. All electrical wiring should comply with your region's electrical codes.
- A source of water, for the aftercooler or optional precooler.** The dryer's aftercooler and optional precooler requires 2 gals./min {7.6 liters/min} tower or city water at temperatures of 40° to 85°F {4° to 29°C}. Piping should be ran to the planned dryer location. Use flexible hose to connect the water pipes to the aftercooler or optional precooler.

NOTE: For the optional water-cooled aftercooler or precooler.

2 Mount the vacuum receiver mounting bracket. Lay out the bolt pattern of the processing machine feed throat on the blank base plate of the vacuum receiver mounting bracket and gasket. Drill holes for the mounting bolts you plan to use. Place the gasket between the feed throat and mounting bracket. Bolt the mounting bracket to the feed throat.

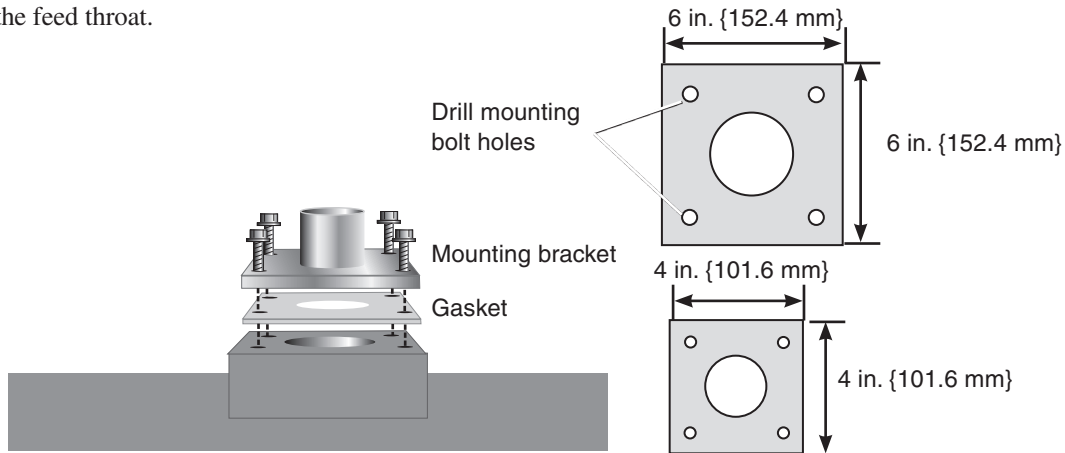

NOTE: You will receive either a 4x4 inch {102 x 102 mm} or 6x6 inch {152 x 152 mm} mounting bracket, depending on the dryer model you have ordered. The mounting bracket is specified on your order. If you need a larger mounting bracket, call Conair Parts at 1-800-458-1960.

Installing the dX

Tools for installation:

- Phillips screwdriver
- Flathead screwdriver

The dX was designed to be mobile. When you move the dX, you will need to mount the vacuum receiver, connect the main power source, connect a water source for the optional aftercooler and/or optional precooler, and connect a compressed air source for the optional self-loading hopper loader. Phasing of electric power should be consistent between locations. The dX has built-in phase detection and will not allow the unit to operate if the phasing is incorrect.

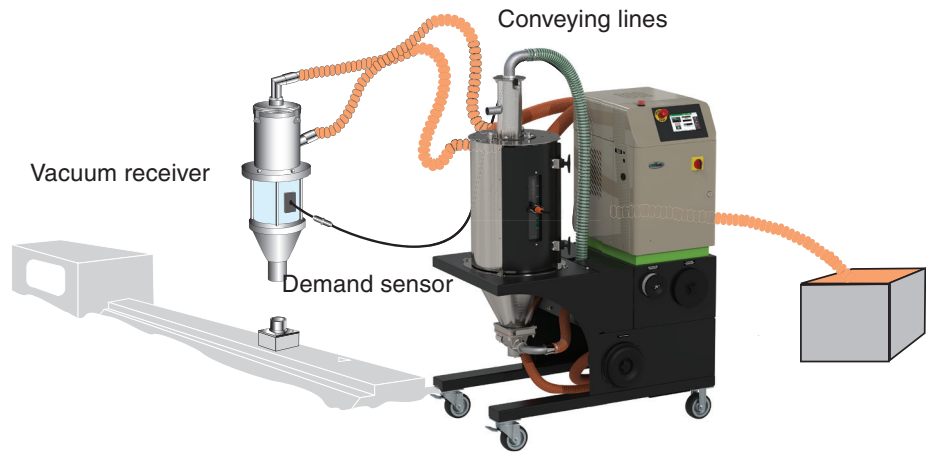

Demand Sensor Connection



The first time you install the dX:

- 1** Move the dX to the processing area. Lock the wheels on the drying cart.
- 2** Mount the vacuum receiver on the feed throat. Push the vacuum receiver onto the mounting bracket.
- 3** Connect the conveying lines.
- 4** Connect the demand sensor to the connection on the dryer frame.
- 5** Connect the main power source.
- 6** Connect a source of water if using the optional water cooled aftercooler and/or optional precooler.

IMPORTANT: Do not run tied to material line. Interference can occur.

TIP: If you are using city water, which may be hard (loaded with minerals), be sure to use de-ionized or distilled water in cases where the water will come in contact with the resin you are using.

Connecting Conveying Lines

The vertical conveying tubes and flexible conveying hoses may have been removed for shipping. To assemble:

- 1 Insert each vertical conveying tube into its quick disconnect fitting on the dX.** Push the tube down until you feel it seat snugly inside the disconnect fitting. Tighten the thumb screws on the fittings to secure the tubes.
- 2 Secure flexible conveying hoses to the vertical tubes with hose clamps.** Insert the tube at least 1 inch {2.54 cm} into the flexible hose. Secure the hose clamp at least 1/4 inch {0.64 cm} from the end of the tube.
- 3 Attach the flexible conveying hoses to the appropriate inlet and outlet of the vacuum receiver.** Push the quick disconnect fitting on the material conveying hose over the material inlet tube. Push the quick disconnect fitting on the return air conveying hose over the conveying air outlet of the vacuum receiver. Tighten the thumb screws on the fitting.

 **NOTE:** dX with long haul conveying option does not include conveying hose. Conair recommends the use of rigid piping. Material lines = 1½" ø. Vacuum lines = 2" ø (not included).

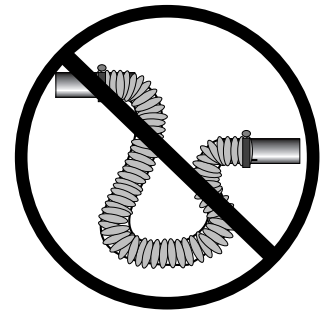
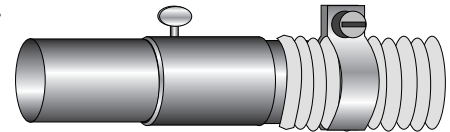
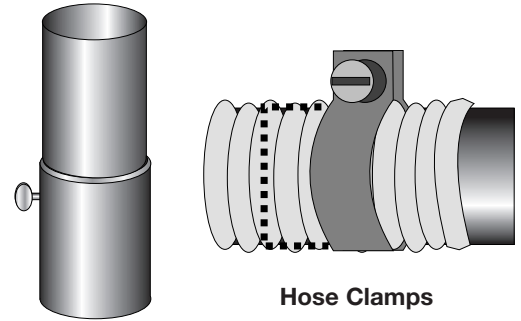

Connecting the Demand Sensor

The capacitive demand sensor monitors the level of material in the viewing chamber of the vacuum receiver when the dX is conveying. The sensor signals the dX control to start the conveying blower whenever the level of material drops below the amount that you want to maintain at the feed throat.

 **NOTE:** Do not allow the flexible hoses to kink or crimp.

- 1 Plug the sensor cable into the multi-pin connector on the side of the dX frame.**

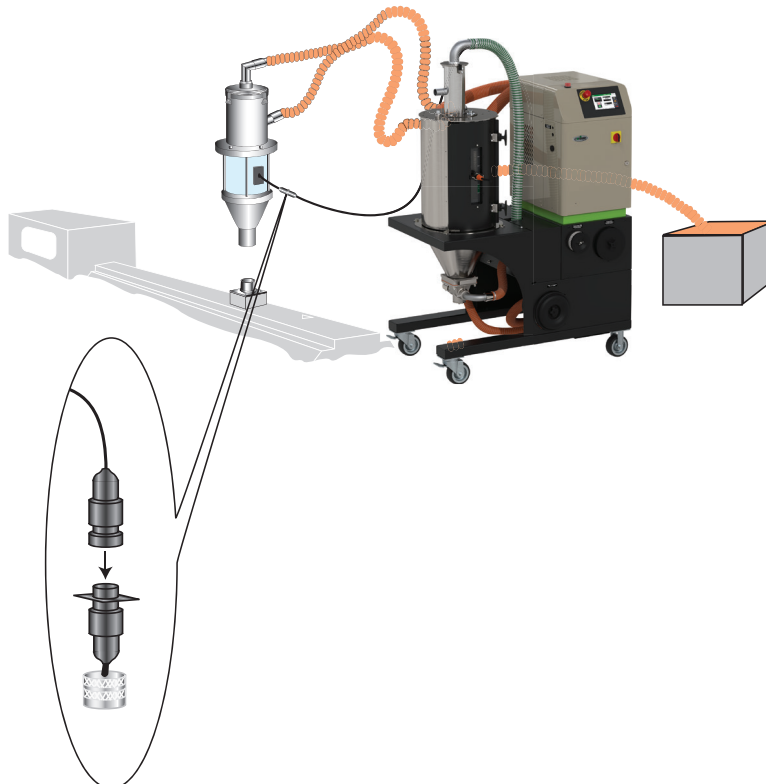

Mounting a Loader on the Hopper

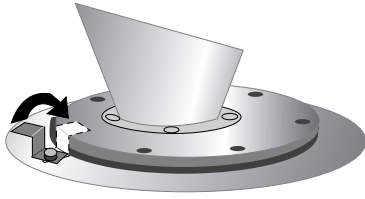

If you have a Conair loader or vacuum receiver, you can use the flange and mounting clips provided on the top of the hopper. Refer to the manuals that came with your receiver or loader for detailed installation instructions.

IMPORTANT: Check to ensure that all material conveying hoses are placed away from the control panel. Static electricity can damage the control circuit.

Connecting Material Lines for Self-Loading (optional)

TIP: Material layering of virgin and regrind material is achieved with an optional ratio valve located at the material inlet of the hopper loader.

When connecting the optional self-loading function of the dX Carousel Plus dryer you will need to make several connections for conveying tubes and the demand sensor for the hopper loader.

Ratio valves are available from Conair.

Contact Conair Parts: (800) 458 1960
From outside of the United States, call:
(814) 437 6861.

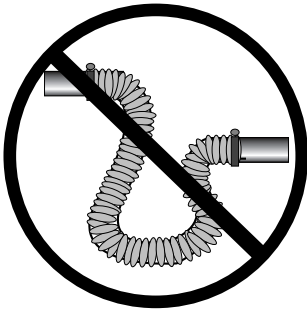

NOTE: Do not allow the flexible hoses to kink or crimp.

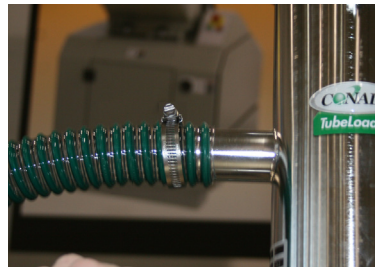

To connect the conveying tubes and demand sensor cables:

1 Mount the loader on top of the hopper. Attach the 10ft. {3.05m} supplied material line to the inlet of the hopper loader. Secure with clamp.



2 Connect a gaylord wand to the material inlet line, then place the wand in your material.



3 Connect the demand sensor to the dryer control box where labeled.



4 Attach the vacuum line to the outlet of the hopper loader. Secure with clamp.

5 Connect the vacuum line to the inlet of the pneumatic valve located on the side of the dryer frame. Secure with clamp.



Connecting the Main Power



CAUTION:



Always disconnect and lock out the main power sources before making electrical connections. Electrical connections should be made only by qualified personnel.

- 1 Open the dryer's electrical enclosure** by turning the disconnect dial on the dryer door to the Off or "O" position. Lock out the main power (see Page 1-6 for complete lock out information). Turn the captive screw, and swing the door open.
- 2 Insert the main power wire through the knockout in the side of the enclosure.** Secure the wire with a rubber compression fitting or strain relief.
- 3 Connect the power wires to the three terminals** at the top of the power disconnect.
- 4 Connect the ground wire to the ground lug** as shown in the photo.

IMPORTANT: Always refer to the wiring diagrams that came with your dryer before making electrical connections.

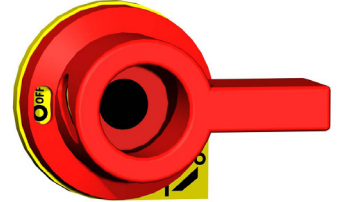

Connecting Compressed Air for Self-Loading (optional)

When connecting the optional self-loading function of the dX Carousel Plus dryer an 80 psi {5.5 bar} compressed air source is required.

To connect the compressed air source:

- 1 Install the 1/4 inch NPT adapter** to the compressed air outlet found on the left side of the dryer frame. Seal adapter threads with nylon tape.
- 2 Attach compressed air hose** to the 1/4 inch NPT adapter.



Air Hose Connection

Checking for Proper Air Flow

CAUTION:

Checking for proper air flow must be performed before filling the hopper with material. Performing this step after the hopper is filled with material could cause damage to the dryer if the airflow direction is incorrect due to improper phase connection. Material from the hopper can be pulled into the process heater, causing permanent damage.

 **NOTE:** Screens shown throughout this guide are for reference only. Data may not be accurate or reflect your configuration.

- 1 Turn on the main power to the dryer.** Make sure the dryer's disconnect dial is in the ON position. This powers up the control.

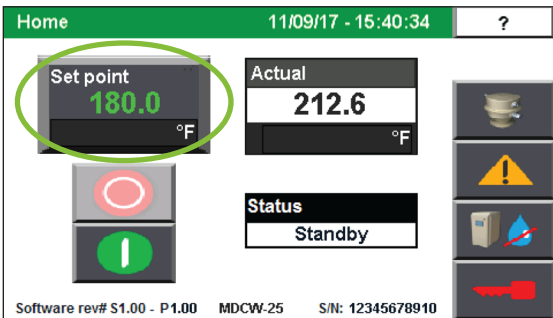

- 2 Press the setpoint box to set the drying temperature.** Enter the low setpoint temperature (150° F {66° C}) on the numeric keypad and press enter.

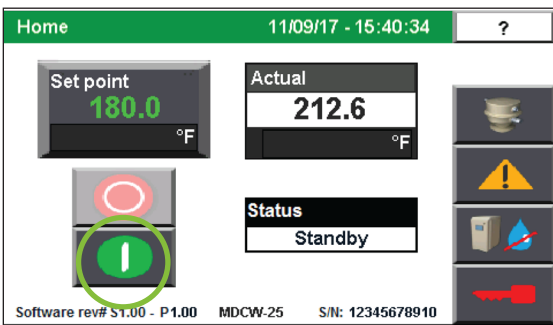
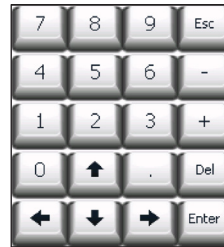

- 3 Press the START button.** Disconnect the process filter and feel for suction at the inlet to the filter. If the airflow is traveling in the correct direction you should feel suction.

CAUTION: Hot Surface

Do not place your hand directly on the delivery air outlet. The outlet and the air can get hot enough to burn your hand.

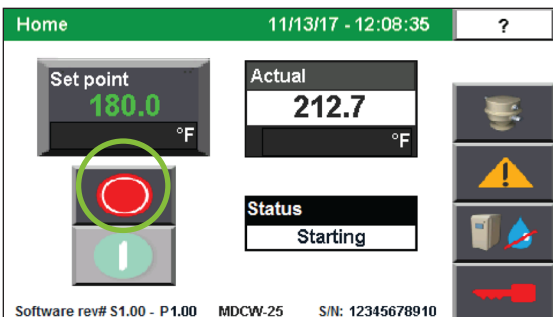

- 4 Press the Stop button.** Reconnect the process filter that was disconnected in Step 3.

Checking for Proper Air Flow (continued)

- 5 **Disconnect the power if the airflow is incorrect**, follow the proper lockout procedure, and swap any two of the three main power wires.

 **WARNING:**

All wiring, disconnects, and fuses should be installed by qualified electrical technicians in accordance with electrical codes in your region. Always maintain a safe ground. Do not operate the equipment at power levels other than what is specified on the machine serial tag and data plate.

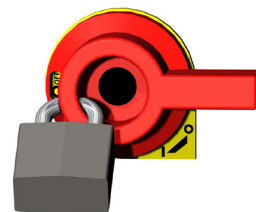

Connecting the Optional Water-Cooled Aftercooler - If Equipped

The optional water-cooled aftercooler and optional precooler require a source of cooling water and a discharge or return line.

To connect water hoses:

- 1 **Connect the water supply line to the aftercooler inlet.** If a manual shut off valve is used, it should be mounted on the inlet line.
- 2 **Connect the water discharge or return line to the aftercooler outlet.**

 **NOTE:** Water to aftercooler should be turned off when the dryer is not running to prevent condensation.

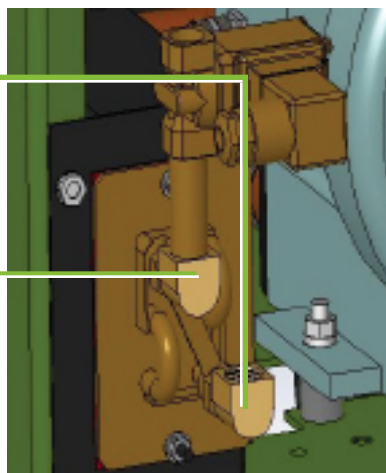

Optional Aftercooler Flow Constant Valve

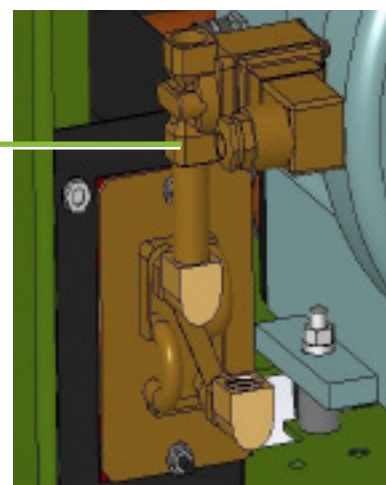

- **TIP:** If you are using city water which may be hard (loaded with minerals), be sure to use de-ionized or distilled water in cases where the water will come in contact with the resin you are using.

- **TIP:** Make the water supply and discharge / return connections with flexible hoses at least 24 in. (61 cm) long. This allows you to easily remove the aftercooler assembly for cleaning.

- **TIP:** To ensure that the aftercooler's copper piping is not damaged or pinched while installing an adapter, use a wrench to brace the aftercooler piping.

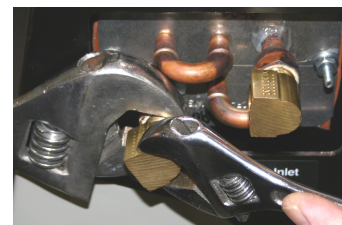

- **TIP:** If an optional flow control is being installed to the aftercooler, the manual shut off valve should be installed on the inlet line for the flow control.



Testing the Installation

You have completed the installation. Now it's time to make sure everything works.

- 1 Make sure there is no material in the hopper.** If you have mounted a loader or vacuum receiver on the hopper, disconnect the material inlet hose at the source or turn off the loader.
- 2 Turn on the main power to the dryer.** Make sure the dryer's disconnect dial is in the ON position. This powers up the control and the display will illuminate.
- 3 Set the drying temperatures.** Enter a low setpoint temperature (150° F {66° C}) on the numeric keypad and press enter.

 **NOTE:** Screens shown throughout this guide are for reference only. Data may not be accurate or reflect your configuration.

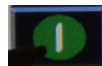
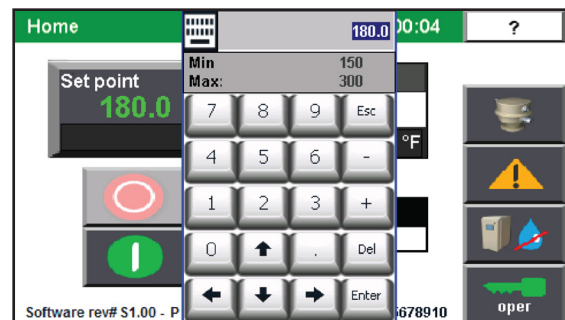
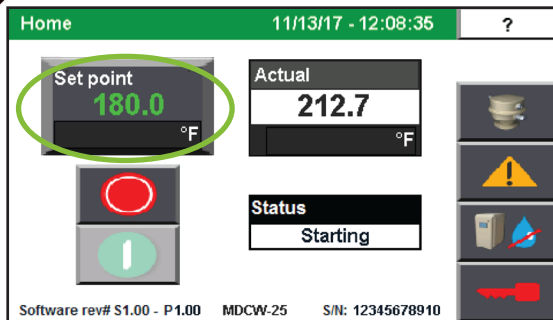

4 Press the START button.

If everything is installed correctly:

- The start button will fade.
- The process and regeneration blowers will turn on.
- The process and regeneration heaters will turn on.
- The status bar will display “Starting”.

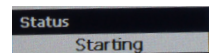

5 Turn ON the hopper loader and machine loader by pressing the loader buttons.

The buttons are greyed when loaders are off, and bold when loaders are on.

- The conveying blower should turn on.

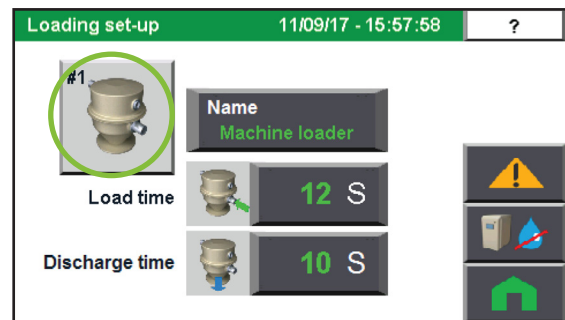
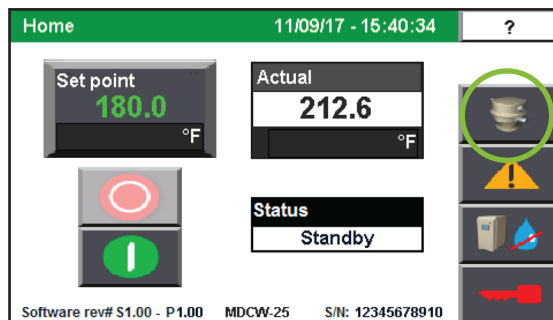

6 Press the loader button again to turn the hopper and machine loaders off.

7 Press the STOP button.

- The blowers will continue running as needed to cool the heaters (until both heaters are less than 150° F {66° C}).



- 8 The test is over.** If the dryer performed the normal operating sequences as outlined, you can load the hopper and begin operation. If it did not, refer to the Troubleshooting section of the User Guide.

Using Communications (optional)

To use the optional Ethernet, see the Addendum for hardware installation and configuration.

The available optional protocols is Modbus TCP/IP.

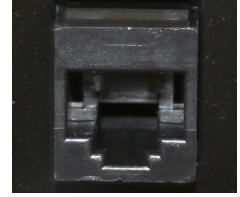

Ethernet Connection

Operation - DC-C Plus Control

The dX Dryer: Control Panel DC-C Plus	4a-2
Control Function Flow Charts	4a-2
Control Function Descriptions	4a-8
To Start Drying	4a-17
To Stop Drying.....	4a-18
Using the Loading Function on the Hopper Loader (optional).....	4a-18
Machine Loader Conveying	4a-19
How to Log In.....	4a-20
Using the Auto Timer	4a-21
Setting High Setpoint Limits	4a-22
Using Dewpoint Control.....	4a-22
Using the Energy Use Monitor	4a-23
Using the Setback Feature.....	4a-23
Setback Feature Guidelines	4a-24
Automatic Cleaning Cycle	4a-25

The dX Dryer: Control Panel DC-C Plus

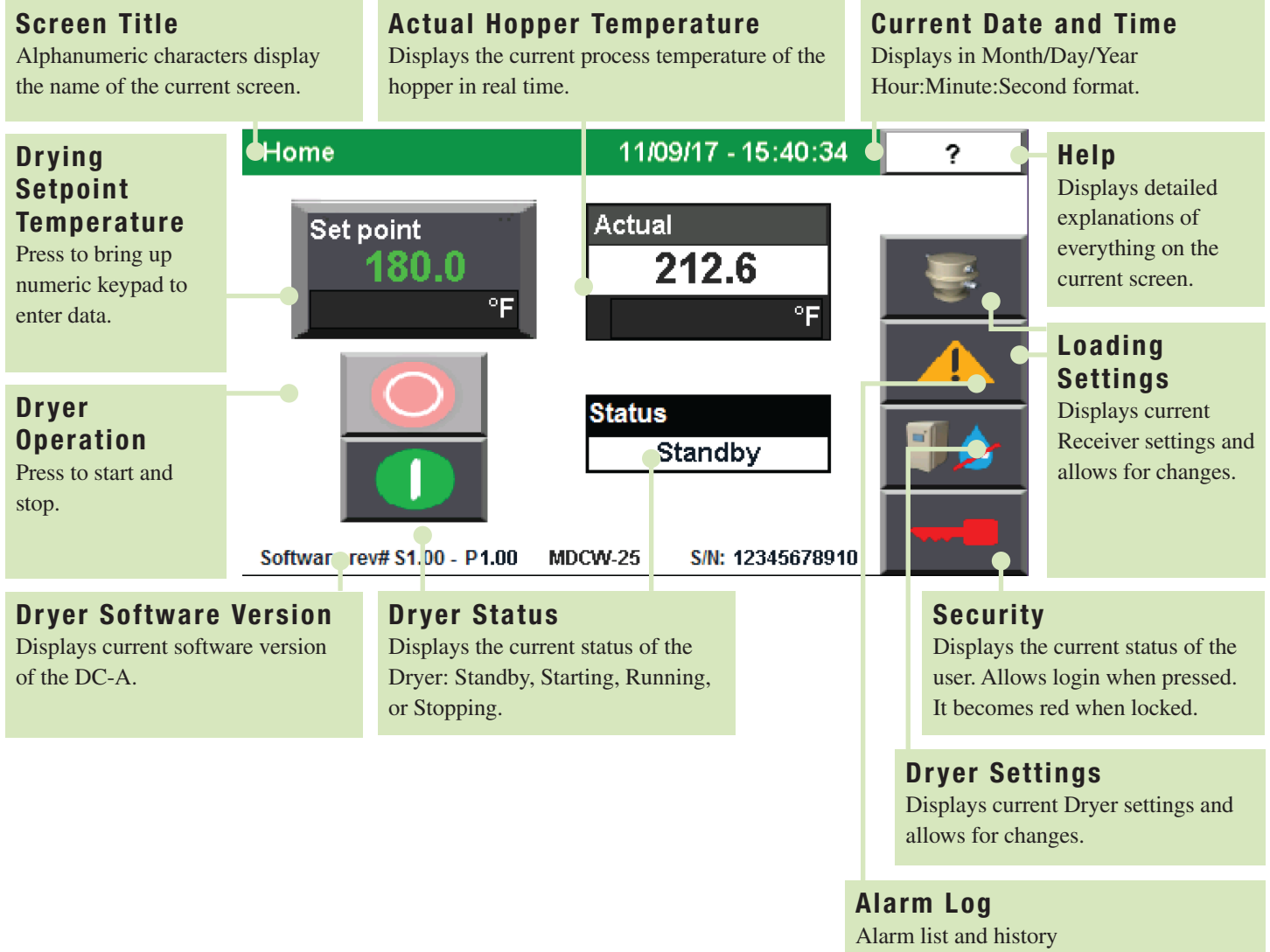

Control Function Flow Charts

The charts beginning on the next pages provide a quick summary of the control functions. For an explanation of each control function, see Control Function Descriptions.

NOTE: In the flow charts of the display screens that follow this page, the screens may display optional functions. If the options were not purchased with the dryer, those functions will not appear. Most options can be purchased and installed in the field.

NOTE: Upon startup, the first time loading each screen may be delayed slightly as the content is loaded. You may notice this mostly on the help screen.

Control Function Flow Charts (continued)

Home

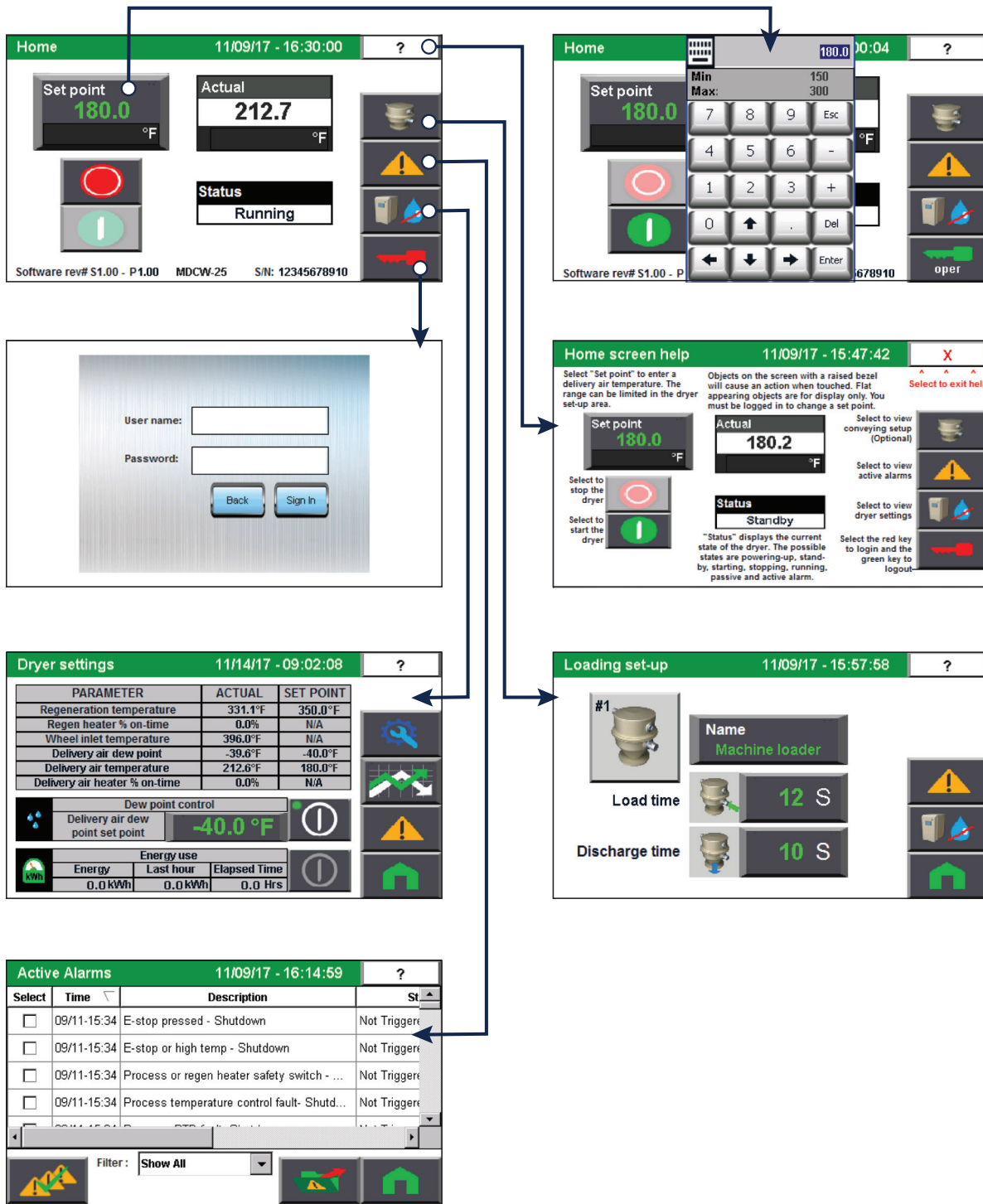

Operation
4a

Control Function Flow Charts (continued)

Loader Settings

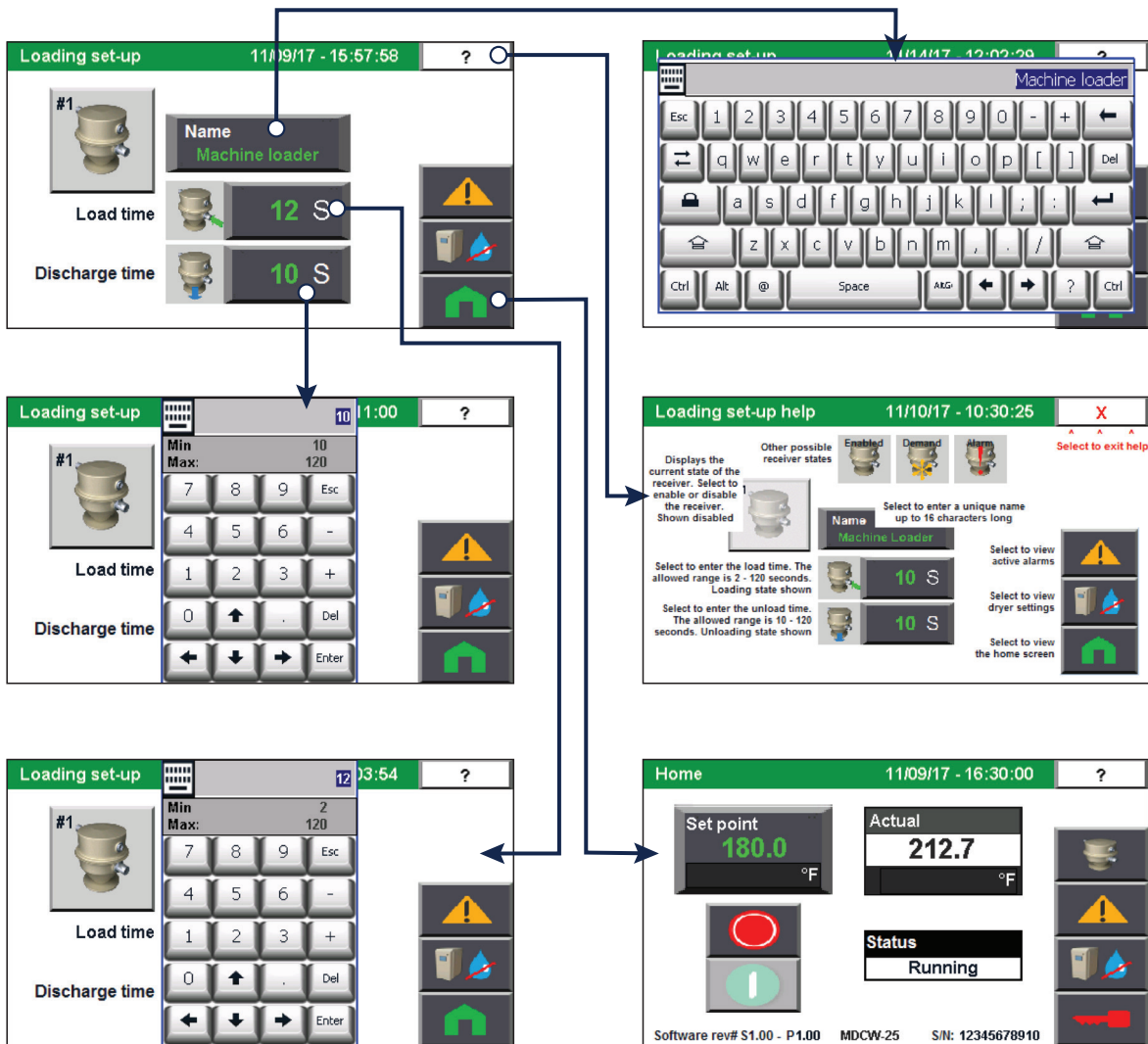

Control Function Flow Charts (continued)

Trends

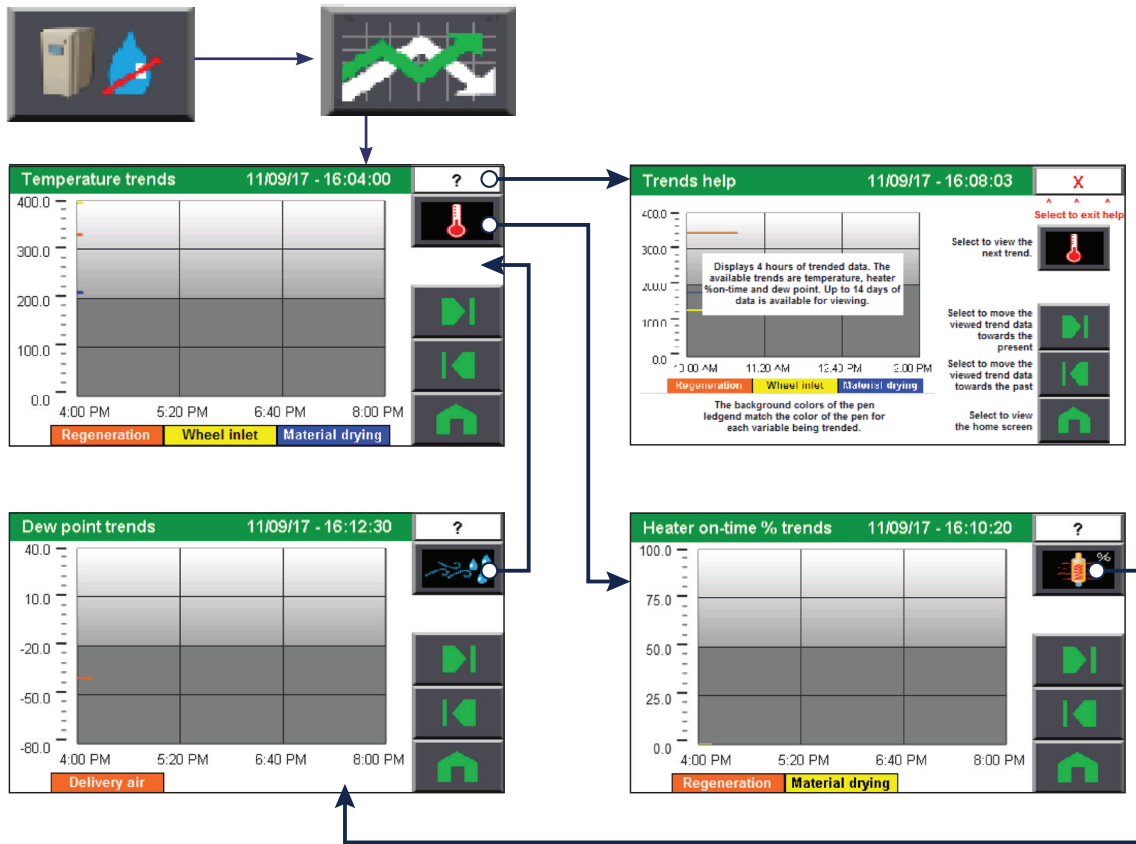

Operation
4a

Control Function Flow Charts (continued)

Alarms

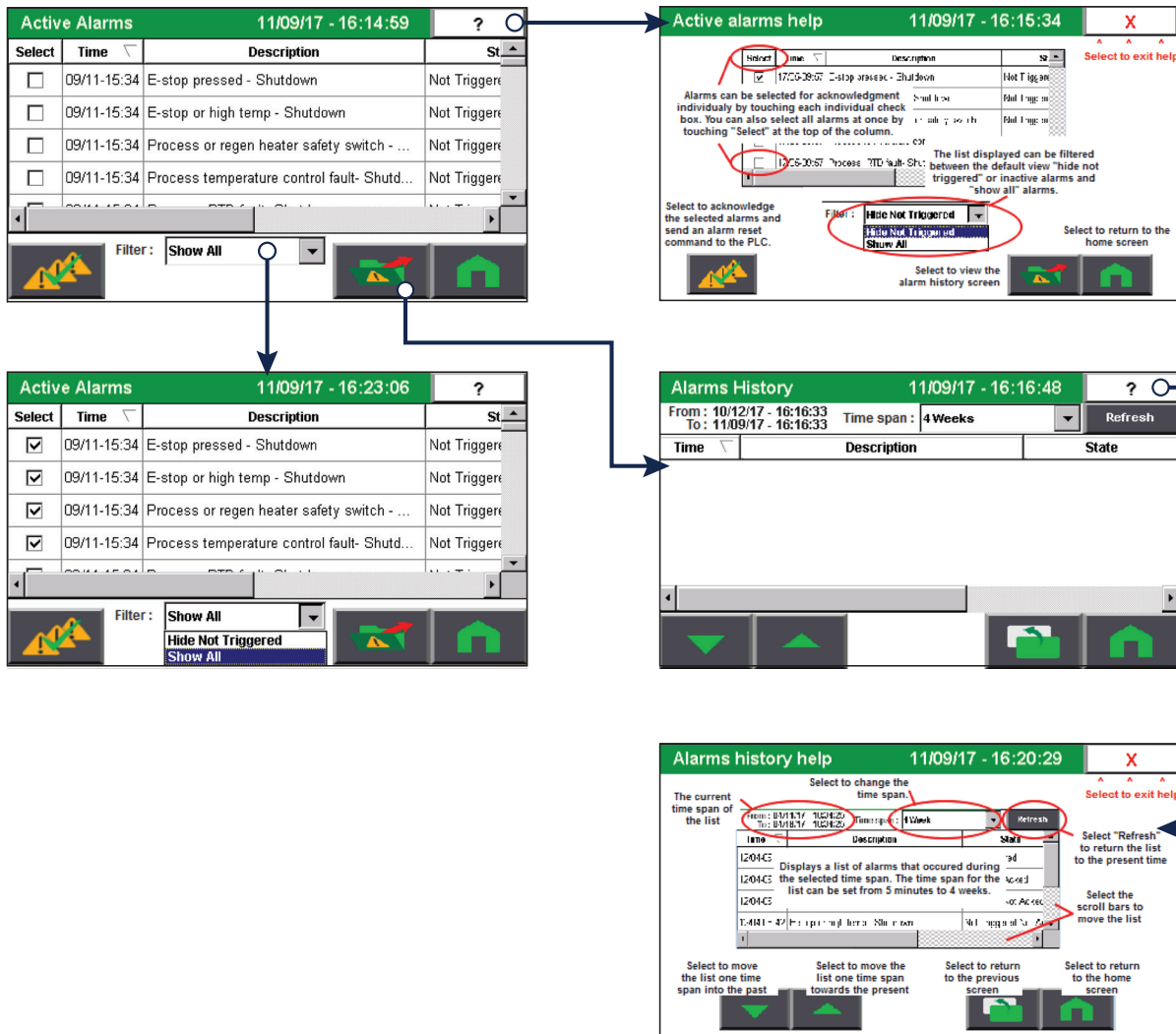

Control Function Flow Charts (continued)

Dryer Settings

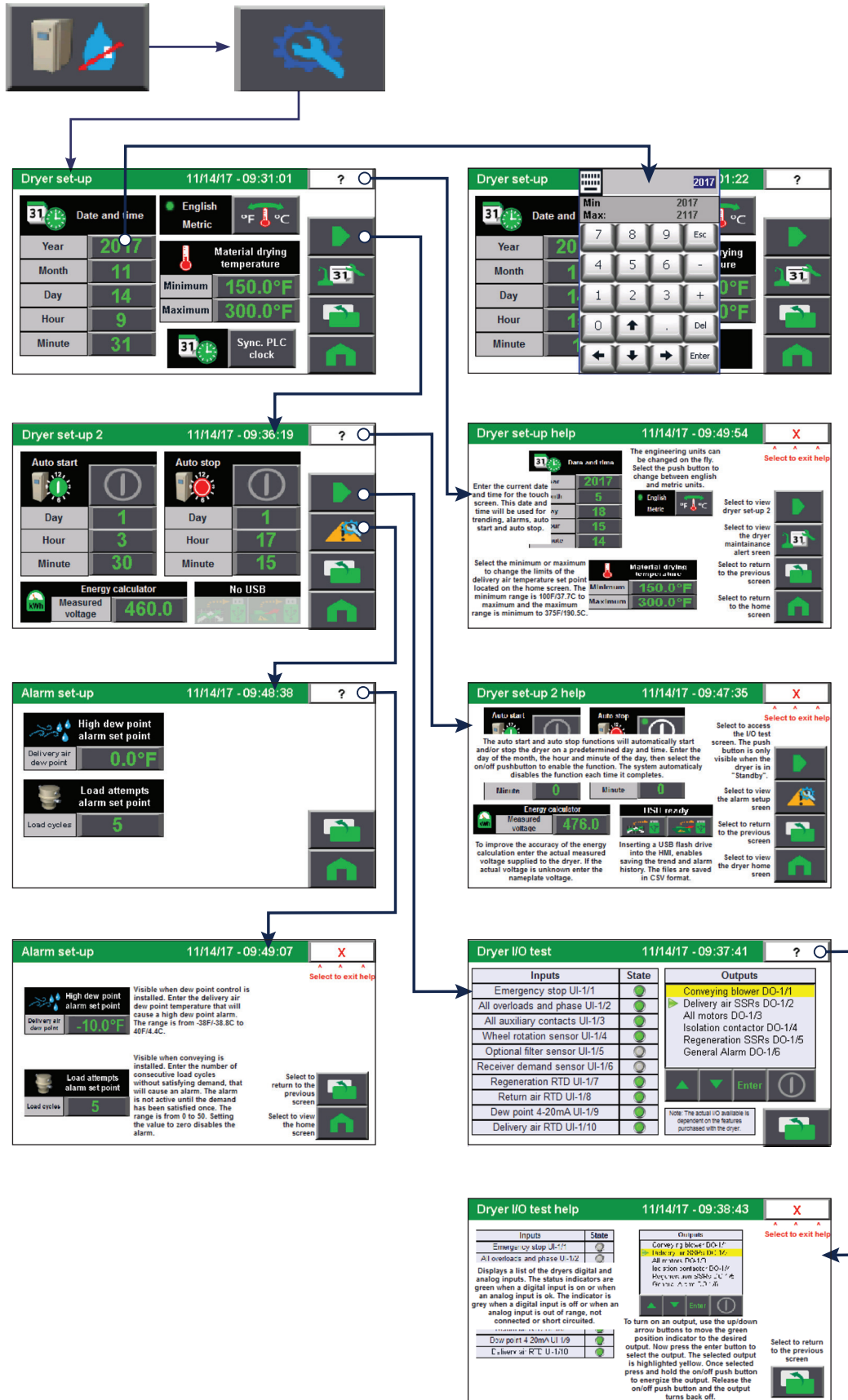

Control Function Descriptions

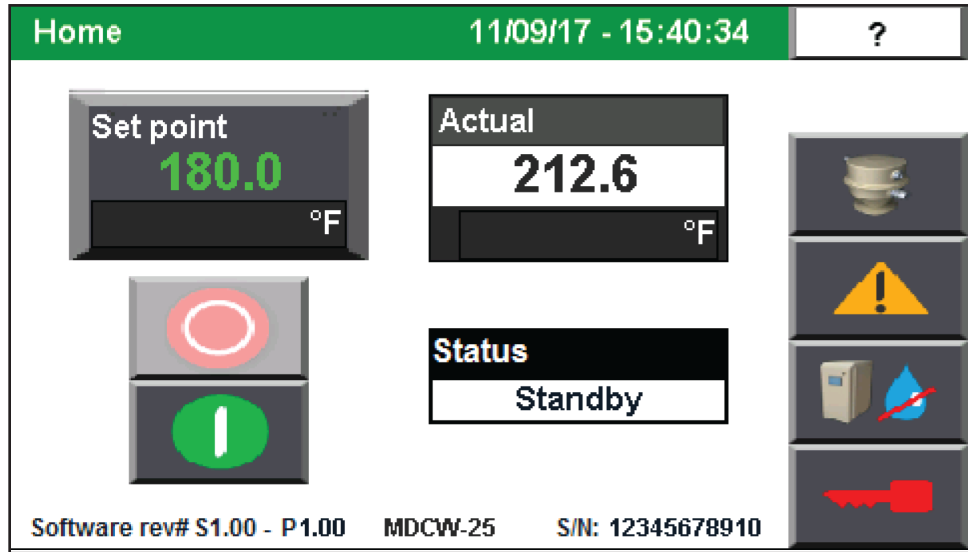

Home Screen

The home screen conveniently displays all information for typical operation. From here, you can view the current Actual temperature, set the Set point, view the dryer status, Start and Stop drying, and Start and Stop conveying. The Help screen will give you information to help with operating the dryer from this screen. The menu buttons on the right allow for navigation to other areas of the dryer control.

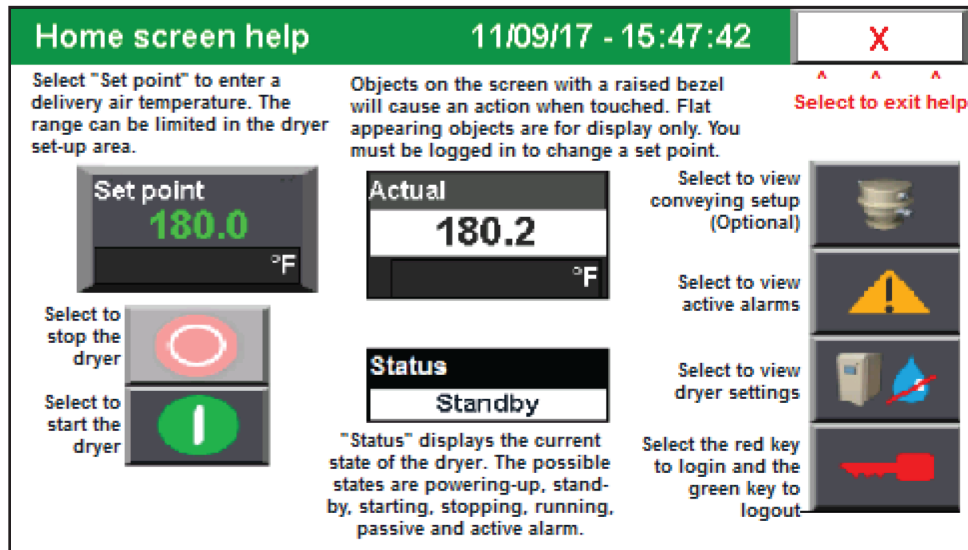

Help Screen – Home

This screen displays helpful information about the dryer home screen.

Control Function Descriptions



Number Pad Pop-up

This number pad will pop up when you've selected a setpoint or variable that can be adjusted. Enter your desired setting, followed by the enter key. Press the delete key (arrow left) to delete a number, or the ESC key to leave the number pad without making any changes.

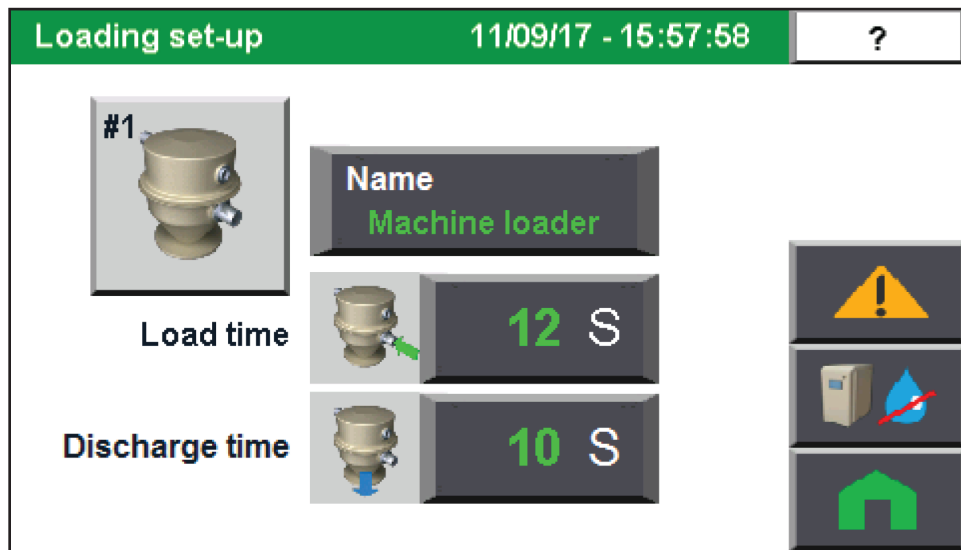

Loading Set-up Screen

This screen allows you to enable and disable loaders, and to change the loader names, load times, and discharge times. Pressing on the loader icon will enable and disable the loader. Pressing on the loader name box will allow for customizing the loader name. Pressing on the load time and discharge time boxes will allow for changes to the times (in seconds).

Control Function Descriptions

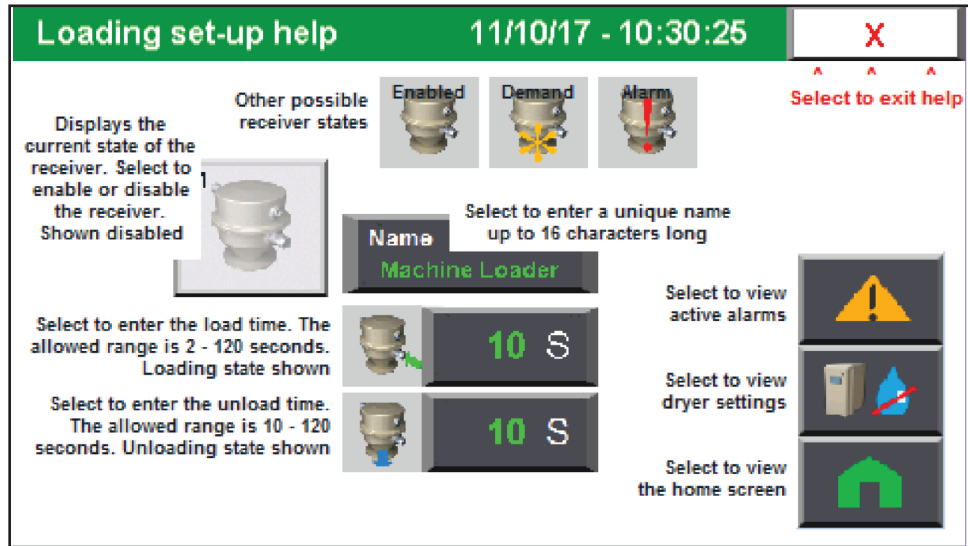

Help Screen – Loading Set-up

This screen will help with setup options on the Loading Setup screen. It notes limits to ranges and other important information.





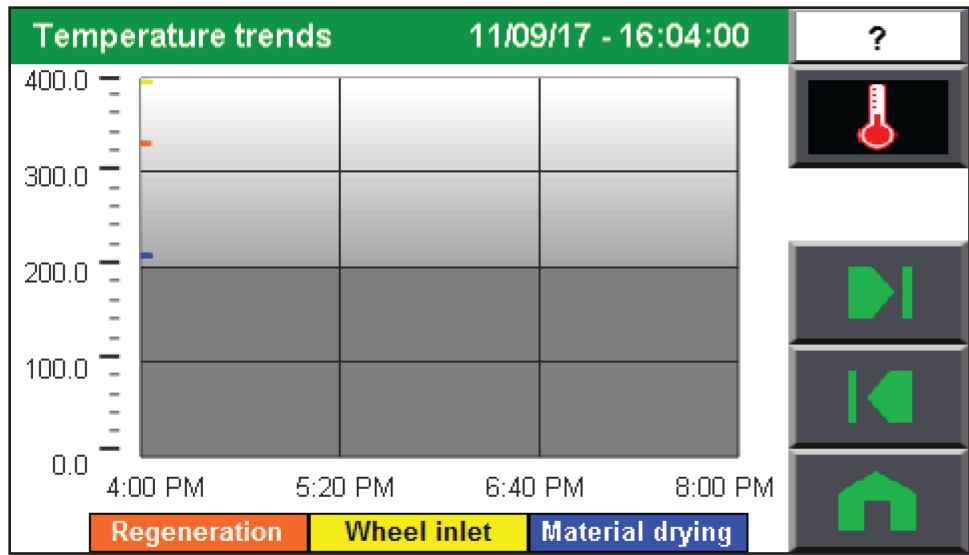

Alphanumeric Pad Pop-up

This keypad will pop up whenever a editable text box is pressed. This box allows for entering user names, passwords, loader names, etc. Press the Enter key once changes are made, or the ESC key to exit the screen without making changes.

Control Function Descriptions



-  Temperature Trend
-  Heater On-Time % Trend
-  Dewpoint Trend
-  Drying Monitor Temperature Trend

Trend Screens

From these four screens, you can view the Temperature Trend, Drying Monitor Temperature Trend (if equipped), Heater On-Time % Trend, and Dewpoint trend. These trending screens can help you optimize performance, and note issues you may be having with you dryer.

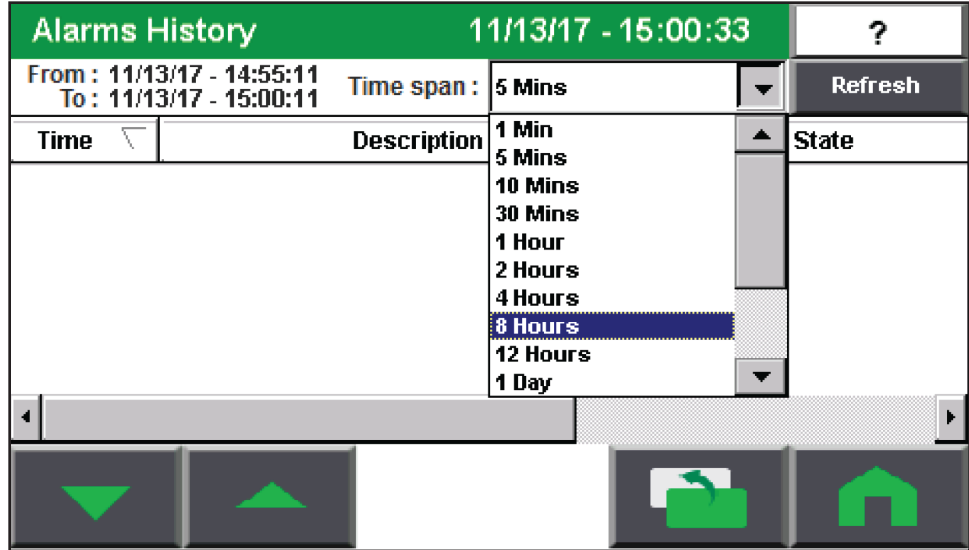

Alarm Log Screen

This screen displays the 100 most recent alarms. It allows you to navigate through the alarm list for more detail, acknowledge all alarms, and change alarm settings.

Control Function Descriptions

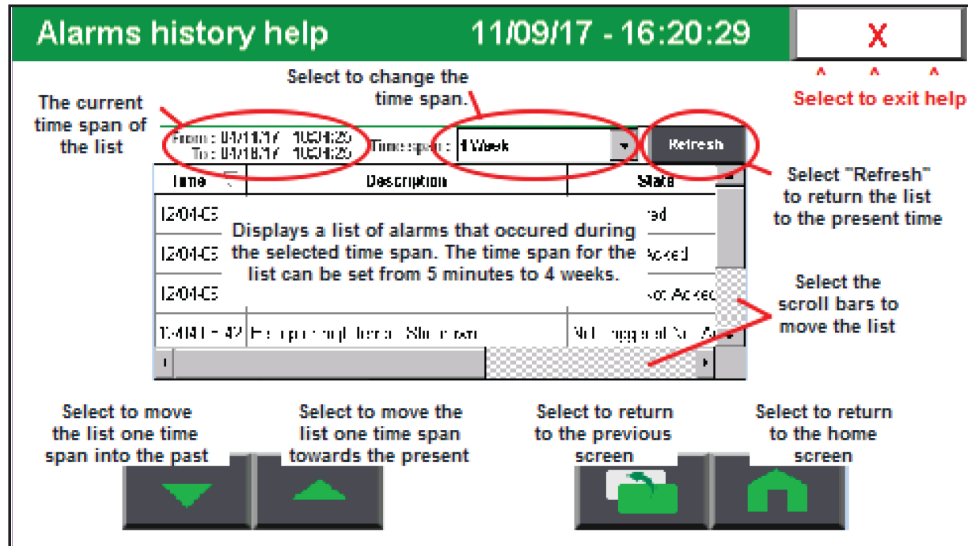

Help Screen – Alarm Log

This screen shows detailed help information for the Alarm Log Screen.

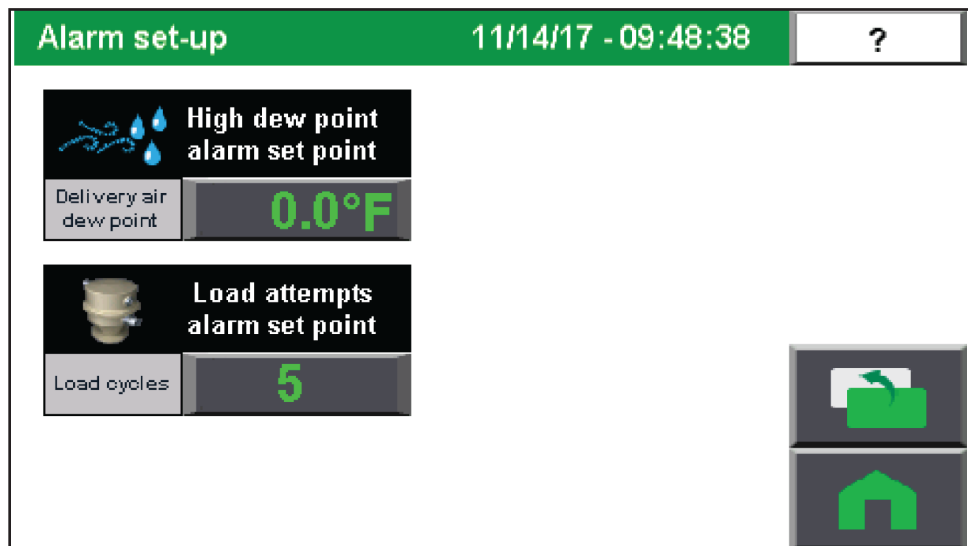

Alarm Set-up Screen

From the Alarm Log Screen, pressing the Setup button takes you to this screen, where you can make adjustments to the user settings which trigger an alarm condition.

☑	09/11-16:27	E-stop or high temp - Shutdown	Triggered N
---	-------------	--------------------------------	-------------

Alarm Banner

The alarm banner will appear on the screen in the event of an alarm that needs addressed by the operator. The banner will give a description of the problem, and the type of alarm. The alarm can be acknowledged here, and the banner can be closed. You can also view the alarm list on the Alarm page.

Control Function Descriptions

PARAMETER	ACTUAL	SET POINT
Regeneration temperature	331.1°F	350.0°F
Regen heater % on-time	0.0%	N/A
Wheel inlet temperature	396.0°F	N/A
Delivery air dew point	-39.6°F	-40.0°F
Delivery air temperature	212.6°F	180.0°F
Delivery air heater % on-time	0.0%	N/A

Dew point control		
Delivery air dew point set point	-40.0 °F	[On/Off]

Energy use		
Energy	Last hour	Elapsed Time
0.0 kWh	0.0 kWh	0.0 Hrs

NOTE: Shown with all options. Your screen may be different.

Dryer Settings Screen

This screen allows you to make changes to some of the dryer settings, and to navigate to the Dryer Setup Screens (if logged in at the appropriate security level). This screen will vary depending on the installed features.

Dewpoint control can be turned on/off and adjusted here. The Energy Meter can be turned on/off here and will display a value so that you can make changes to improve energy consumption.

This screen also allows for making adjustments to Setback Control settings. When enabled, the Setback Control will set the material drying temperature back to the “Setback to” value when the air temperature exiting the drying hopper reaches the Setpoint value for 5 minutes. When the air temperature exiting the drying hopper reaches the “Reset at” set point for 2 minutes, the material drying temperature returns to the original value.

In Manual mode, all set points are entered manually, based on your experiences. In Auto mode, the “Setback to” and “Reset at” values are calculated. Select the on/off push button to turn the control on or off. Select the M/A arrow button to switch between Manual and Auto modes.

When Dewpoint control is active, flashing text stating “Dewpoint Control Active” will appear to the right of the drying wheel in the graphic on this screen. When Clean Cycle is active, flashing text stating that “Clean Cycle Active” will appear to the right of the drying wheel in the graphic on this screen. Clean Cycle occurs after every 24 hours of accumulated run time. When Clean Cycle is active, you will notice that the regeneration temperature increases. This is normal. Refer to the Help screen for more information.

NOTE: For a resin (with “predictable properties”) such as Polypropylene (PP), running in Auto mode should work fine. When using another resin [e.g., polyethylene terephthalate (PET)] where there is “less operating history”, running in Manual mode may be advisable until one is confident with the performance of the dryer in drying this resin.

Control Function Descriptions

Dryer settings help
11/13/17 - 10:17:15
X

PARAMETER	ACTUAL	SET POINT
Regeneration temperature	325.0°F	350.0°F
Delivery air temperature	N/A	N/A
Delivery air heater % on-time	N/A%	N/A

Select to exit help

This pushbutton is visible when logged in as maint, super or admin. Select to access dryer setup.

Select to view trend screens

Select to view active alarms

Select to view the home screen

The list of dryer settings provides a quick overview of the system parameters. It is display only.

When enabled, dew point control varies the regeneration temperature of the wheel to maintain the desired delivery air dew point.

Dew point control
ⓘ

Delivery air dew point set point
-40.0 °F
ⓘ

When enabled, the energy meter displays the calculated energy use. The last hour value can be monitored to see if conditions have improved or worsened energy consumption.

Energy	Last hour	Elapsed Time
0.0 kWh	0.0 kWh	0.0 Hrs

Help Screen– Dryer Settings

This screen gives detailed information to help you adjust the settings on the Dryer Settings Screen.

Dryer set-up
11/14/17 - 09:31:01
?

31
Date and time

Year	2017
Month	11
Day	14
Hour	9
Minute	31

English
Metric

°F
°C

Material drying temperature

Minimum	150.0°F
Maximum	300.0°F

Sync. PLC clock

▶

🔄

🏠

Dryer Set-up Screen

This screen may vary depending on the installed features. This screen allows for the Auto Start function to automatically start the dryer at a desired time. Enter the day of the month (1-31), the hour of the day (1-24), and the minutes of the hour (0-59) and turn on the function. After starting, the Auto Start automatically resets to off or disabled. The Material Drying Minimum and Maximum setpoints can also be set on this screen. The range set at the factory is 100°F to 375°F {37.7-190.5°C}. The Reset Password box is only visible when logged in as an Administrator. Select it to reset a user’s password to a new password, when the old password is unknown. Select Change Password to change the password of the user currently logged in. The HMI and PLC Ethernet settings are display only information. Select the “Close Runtime” button only if you wish to exit the HMI operating system. Press the arrow button to navigate to the I/O test screen.

4a-14 | Operation

(Continued)

Control Function Descriptions

Dryer set-up help 11/14/17 - 09:49:54 X

Date and time

Enter the current date and time for the touch screen. This date and time will be used for trending, alarms, auto start and auto stop.

Year	2017
Month	5
Day	18
Hour	15
Minute	14

Select the minimum or maximum to change the limits of the delivery air temperature set point located on the home screen. The minimum range is 100F/37.7C to maximum and the maximum range is minimum to 375F/190.5C.

Material drying temperature

Minimum	150.0°F
Maximum	300.0°F

The engineering units can be changed on the fly. Select the push button to change between english and metric units.

English Metric °F °C

Select to view dryer set-up 2

Select to view the dryer maintenance alert screen

Select to return to the previous screen

Select to return to the home screen

Select to exit help

Help Screen – Dryer Set-up

This screen gives detailed information to help you adjust settings on the Dryer Setup Screen.

Dryer I/O test 11/14/17 - 09:37:41 ?

Inputs	State
Emergency stop UI-1/1	●
All overloads and phase UI-1/2	●
All auxiliary contacts UI-1/3	●
Wheel rotation sensor UI-1/4	●
Optional filter sensor UI-1/5	●
Receiver demand sensor UI-1/6	●
Regeneration RTD UI-1/7	●
Return air RTD UI-1/8	●
Dew point 4-20mA UI-1/9	●
Delivery air RTD UI-1/10	●

Outputs

- Conveying blower DO-1/1
- Delivery air SSRs DO-1/2
- All motors DO-1/3
- Isolation contactor DO-1/4
- Regeneration SSRs DO-1/5
- General Alarm DO-1/6

▲ ▼ Enter ⏻

Note: The actual I/O available is dependent on the features purchased with the dryer.

Dryer I/O Test Screen

This screen allows for testing of various outputs of your dryer. To turn on an output, use the up/down arrow buttons to move the yellow indicator to the output you wish to energize. Press the Enter button to select the output. Once selected, press and hold the On/Off push button to energize the output. Release the On/Off push button to turn the output off.

NOTE: After selecting an output with the up/down arrow, you must press enter to finish the selection prior to testing that output.

Control Function Descriptions

Dryer I/O test help 11/14/17 - 09:38:43

Inputs	State
Emergency stop UI-1/1	
All overloads and phase UI-1/2	
Displays a list of the dryers digital and analog inputs. The status indicators are green when a digital input is on or when an analog input is ok. The indicator is grey when a digital input is off or when an analog input is out of range, not connected or short circuited.	
Dew point 4 20mA UI 1/9	
Delivery air RTU UI-1/10	

Outputs:

- Conveying blower DO-1/1
- Delivery air SSRs DO-17**
- All motors DO-1/1
- Isolation contactor DO-1/1
- Regeneration SSRs DO-1/1
- Grind Air DO-1/1

To turn on an output, use the up/down arrow buttons to move the green position indicator to the desired output. Now press the enter button to select the output. The selected output is highlighted yellow. Once selected press and hold the on/off push button to energize the output. Release the on/off push button and the output turns back off.

Select to exit help

Select to return to the previous screen

Help Screen – Dryer I/O Test

This screen provides detailed descriptions of how to use the Dryer I/O Test functionality of the control.

Highest permission

ADMIN

SUPER

MAINT

Lowest permission

OPER

No security enabled

Loading set up 11/14/17 - 12:02:29

Machine loader

Security Login Pop-up

This page pops up after pressing the Security Key button to log in as a user. After logging in (see table below for login information), the Security Key button will display the current login level of the user.

Level	User	Password	Password Editable
1 (Low)	oper	oper	No
2	maint	maint	Yes
3	super	super	Yes
4 (High)	admin	admin	Yes + reset

To Start Drying

- 1** Make sure there is material in the hopper.
- 2** Turn on the main power to the dryer. Make sure the dryer's disconnect dial is in the ON position. This powers up the control.
- 3** Set the drying temperature. Press the Setpoint Temperature button, then adjust the Setpoint. Enter the temperature on the numeric keypad and press enter.

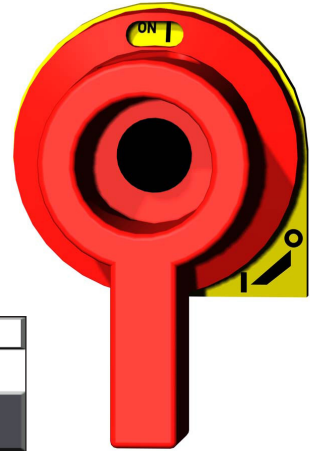

4 Press the START button.

If everything is installed correctly:

- The start button will fade.
- The process and regeneration blowers turn on.
- The process and regeneration heaters turn on.
- The status bar will display “Starting”.
- After the heaters turn on, the status bar will display “Running”.

To Stop Drying



- 1 Press the STOP button.
 - The blowers continue running for a few minutes to cool the heaters.
 - The status bar will display “Stopping”.
- 2 Be sure to disconnect and lockout the main power if you have stopped the dryer to perform maintenance or repair.

IMPORTANT: Do not use the main power switch to stop the dryer. Turning off power to the control and dryer during normal operation prevents the necessary cool-down period, and can trigger the shutdown/high temperature alarm during your next drying cycle.



CAUTION:

Improper shut down can cause damage to your dryer.

Using the Loading Function on the Hopper Loader (optional)

- 1 Connect the conveying hose and/or pick-up wand from the material source to the inlet on the hopper loader.
- 2 Connect a clean, dry compressed air source supplying 80 psi of compressed air to the threaded coupling on the side of the dX dryer.
- 3 Set the Loader settings.
- 4 Press the Loader button.
- 5 Set the load and discharge times.

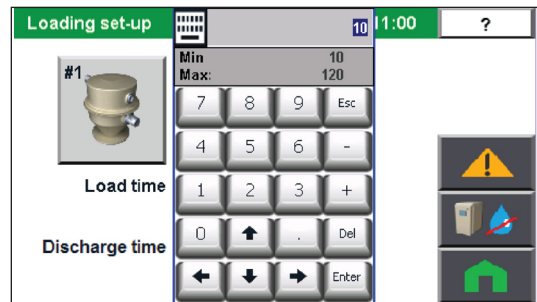
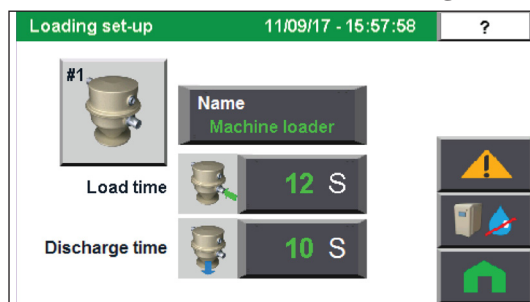
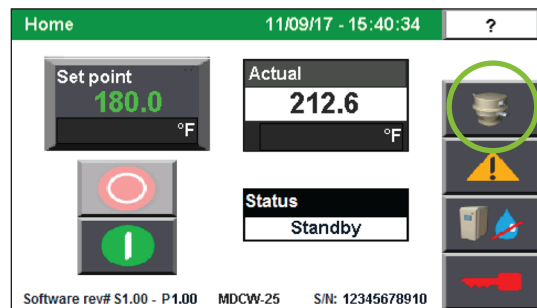

- 6 Adjust the hose connection on the pick-up wand to cover the number of holes to maximize the material flow.
- 7 Press the Loader icon on the home page and turn on loading for each Loader.

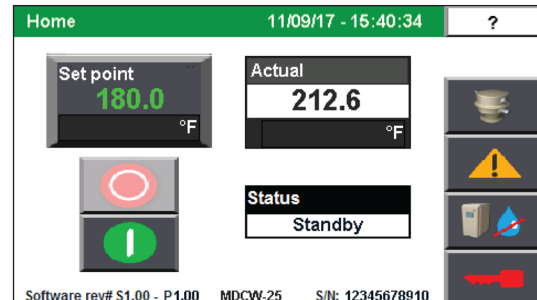

Note: If your loading system is configured for ratio, a percentage adjustment field will display here.

Machine Loader Conveying

- 1 Move the dX to the processing machine.** Lock the wheels and connect the main power source. Connect the water source if you have an aftercooler. Connect compressed air if the self-loading option is being used.
- 2 Mount the vacuum receiver on the feed throat.** Push the vacuum receiver onto the mounting bracket.



- 3 Place the appropriate material insert inside the distribution box.**
- 4 Make sure all hoses are connected securely.**
- 5 Adjust the demand sensor.** Position the sensor at the lowest level of material that you want to maintain in the viewing chamber before another load cycle begins. Make sure the sensor rests against the sight glass.
- 6 Set the load time.**
- 7 Start conveying.** Turn the “Loader” ON.

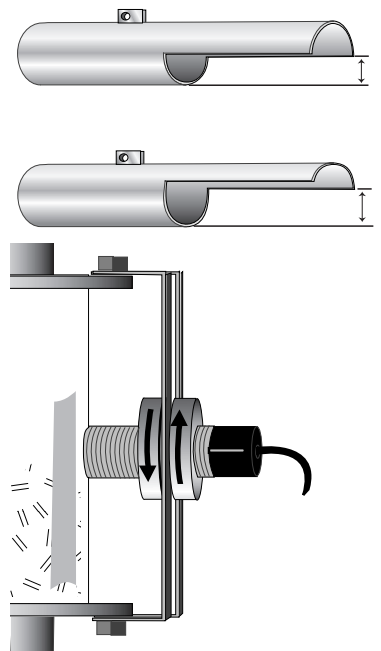

How to Log In

Level	User	Password	Password Editable
1 (Low)	oper	oper	No
2	maint	maint	Yes
3	super	super	Yes
4 (High)	admin	admin	Yes + reset

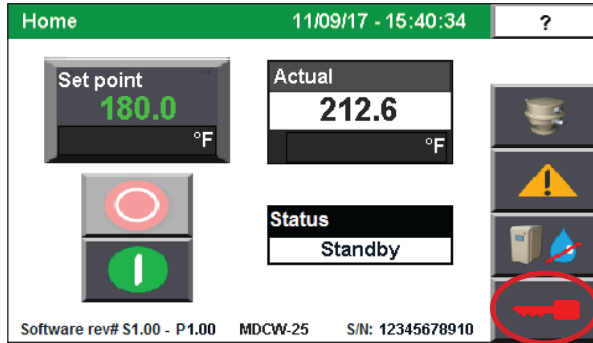

1 Select the Red key to login.

-  Highest permission
ADMIN
-  SUPER
-  MAINT
-  Lowest permission
OPER
-  No security enabled



 **NOTE:** Use-level will be shown on key when login is successful.

Using the Auto Timer

You can set the dryer to start automatically using the Auto Start function. The supervisor password is necessary to use this function.

Programming Auto Start

The Auto Start function can be programmed from the Dry Setup 2 screen. This screen can be accessed by pressing the Dryer Setup button from the home screen and then the arrow right button.

Once the Auto Start has been programmed dryer will automatically start at the set time.

NOTE: Conair is not responsible for damage caused by excessively high drying setpoints that are not in accordance with your drying material recommendations.

NOTE: Software may allow the process temperature setpoint limit up to 450°F {232°C}; however, Conair does not recommend a setpoint limit over 375°F due to nuisance alarms.

NOTE: To avoid nuisance alarms Conair recommends that the low setpoints be set to 150°F {66°C} or above.

Setting High Setpoint Limits

You can protect your drying process by preventing someone from entering process temperatures above or below an acceptable level for the material. You can also set the high and low limits equal to the process temperature to prevent accidental or unauthorized changes to the setting during operation. Users must be logged in with the appropriate user level to change these settings.

- 1 Turn on the main power to the dryer.
- 2 Press the dryer setup button on the home screen.
- 3 Then set the minimum and maximum drying temperature setpoint.

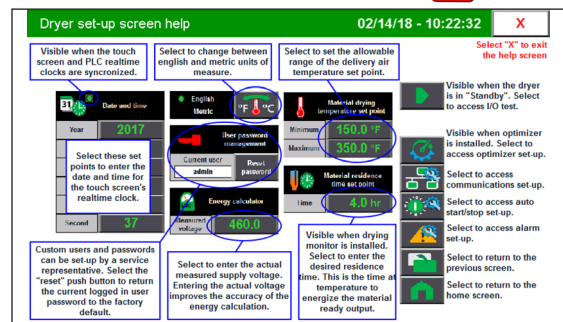
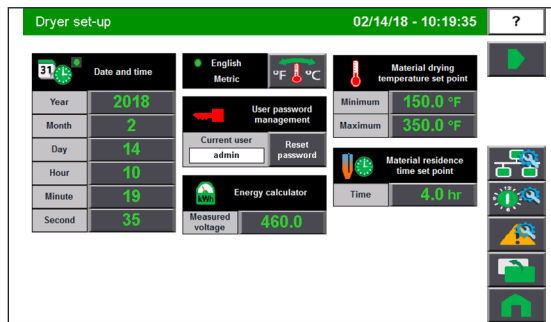

Using Dewpoint Control

Note: Make sure your setback temperature is approximately 40° F above your return air temperature when using this feature.

Your dryer is equipped with a dewpoint monitor and dewpoint control features. You can choose to use it as a monitor only device, or to maintain a steady dewpoint that you select with the dewpoint control. Dewpoint control will vary the regeneration air temperature to condition the desiccant to the level necessary to maintain the desired dewpoint.

Dewpoint Control

NOTE: The supervisor's password is necessary.

NOTE: When Dewpoint Control is active, "Dewpoint Control Active" text will flash to the right of the drying wheel graphic on the Dryer Settings screen.

- 1 From the home screen, select "Dryer Setup" to get to the "Dryer Setup screen".
- 2 Press the arrow navigation button on the dryer setup screen to view the Dryer Settings screen.
- 3 Turn Dewpoint Control on or off by pressing the button.
- 4 Adjust the Dewpoint Control setpoint by pressing the text block.

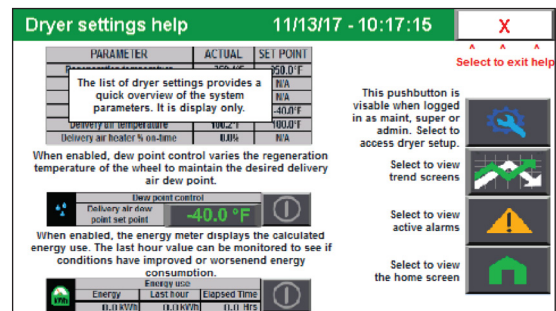
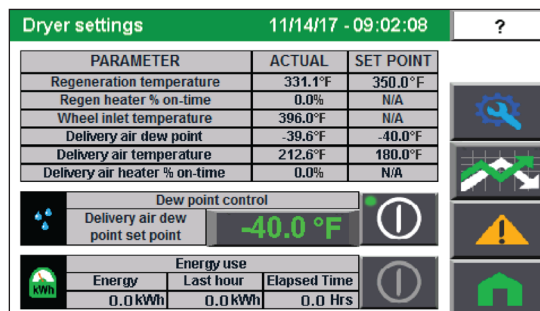

Using the Energy Use Monitor

- 1 From the home screen, select “Dryer Setup” to get to the “Dryer Setup Screen”.
- 2 Press the arrow navigation button to navigate to the Dryer Settings Screen.
- 3 Turn Energy Use monitoring on or off by pressing the  button.

Using the Setback Feature

The DC-C Control comes standard with setback installed, but disabled. You can choose to set the mode to “Off”, “Auto”, or “Manual”. Refer to the Control Function Descriptions later in this section for more detailed information.

This feature is designed to save you money on energy costs and help to keep you from over drying your material.

This is how setback operates when the control setback mode is set on Temperature.

The control monitors the temperature of the air exiting the drying hopper. If that temperature reaches a customer-entered setpoint, the delivery process air temperature will automatically setback to a customer-entered setpoint. Then, if the air exiting the drying hopper drops below the customer-entered temperature an amount greater than what is desired, the process temperature will automatically reset back to the original value.

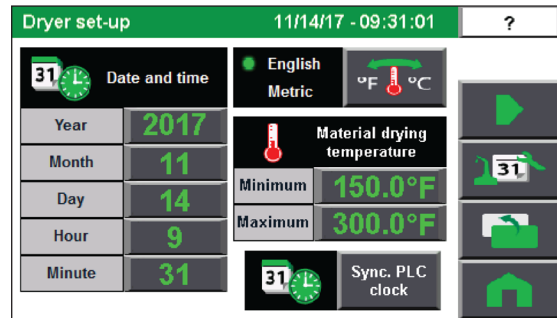

To Activate Setback:

- 1 From the home screen, select “Dryer Setup” to get to the “Dryer Setup Screen”.
- 2 Press the arrow navigation button to navigate to the Dryer Settings Screen.
- 3 **Set the Setback settings.** Set the setback process temperature. This is the setpoint at which the process temperature will go to once the control goes into setback. The actual temperature on the default screen will still show the actual temperature measured at the hopper inlet. The setpoint shown on the default screen will still show the original setpoint. The word “Setback” will appear on the Actual Temp.

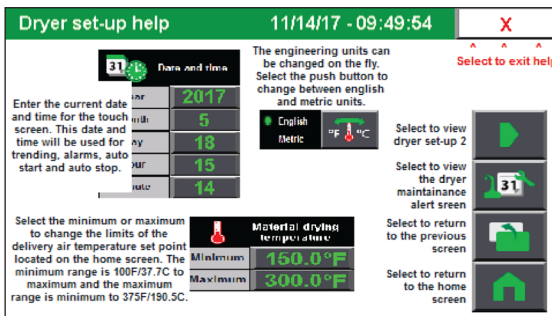

Setback Feature Guidelines

Careful selection of setpoint values in these functions is necessary for the setback to operate properly. The following table is only a guideline of recommended settings for these setpoints. It will be necessary for each customer to determine the best setpoints for their application based on experience.

Normal Drying Temp	Setback Return Temp	Setback Temp (Process)
160° F {71° C}	120° F {49° C}	150° F {66° C}
240° F {116° C}	135° F {57° C}	180° F {82° C}
300° F {149° C}	160° F {71° C}	200° F {93° C}
340° F {171° C}	180° F {82° C}	220° F {104° C}

A recommended way to determine the “Setback” setpoint is to monitor the actual temperature of this function during pre-drying of your material at start-up, and while running at your normal maximum material throughput. The “Setback” setpoint should be set 10 to 20° above maximum temperature noted in these situations.

The “Setback” setpoint you select should be adequate to reduce the temperature significantly enough to prevent over-drying of your material. However, keep in mind that the cooler the temperature selected, the longer it will take for the material to heat back up to its proper drying temperature once the dryer comes out of Setback mode.

When drying at low temperatures (for example 160 - 180° F {71 - 82° C}), you are able to setback the temperature only a small amount. The “Setback Temperature (Process)” should not be set lower than 150° F {66° C}, even if the control will allow it. It is very likely the dryer will not be able to achieve low temperatures without adding additional cooling to the process air circuit. The maximum achievable setpoint is dependent on the temperature of the return air coming back to the dryer. As the return air temperature climbs, the temperature that the dryer is capable of controlling at climbs. For example, if the return air to the dryer is 110° F {43° C}, the dryer may not be able to control at a “Setback” setpoint below 150 - 155° F {66 - 68° C}.



NOTE: Selecting too low of a setpoint may result in nuisance Process Temperature Loop Break alarms if the dryer is not able to achieve this setpoint.

Setback Auto vs Manual Mode

Typically, the Auto Setback mode will be used in most instances. The Manual Mode is available for operators who want to set specific ranges for Setback operation. In Auto mode, these temperatures are calculated by the dryer.

Automatic Cleaning Cycle

In order to maintain dryer efficiency, the DC-C Control initiates a Cleaning Cycle for the drying wheel after every 24 accumulated hours of run time. During this period, you will see “Clean Cycle Active” text flash to the right of the drying wheel graphic on the Dryer Settings screen.

During Clean Cycle operation, you will notice that the regeneration temperature increases, in order to properly clean the dryer and ensure optimal operation. This is normal. This Clean Cycle will not affect material drying, still allows changes to be made to the drying process, and will last anywhere from one hour to two hours, depending on your current drying temperature when the Clean Cycle initiates. If the dryer is stopped or turned off during the Cleaning Cycle, the Cleaning Cycle will stop and immediately resume when the dryer is re-started.

Operation - DC-C Premium Control

The dX Dryer: Control Panel DC-C Premium	4b-2
Control Function Flow Charts	4b-2
Control Function Descriptions	4b-8
To Start Drying	4b-17
To Stop Drying.....	4b-18
Using the Loading Function on the Hopper Loader (optional).....	4b-18
Machine Loader Conveying	4b-19
How to Log In.....	4b-20
Using the Auto Timer	4b-21
Setting High Setpoint Limits	4b-22
Using Dewpoint Control.....	4b-22
Using the Energy Use Monitor	4b-23
Using the Setback Feature	4b-23
Setback Feature Guidelines	4b-24
Material Recipe Screens.....	4b-25
Automatic Cleaning Cycle	4b-26

The dX Dryer: Control Panel DC-C Premium

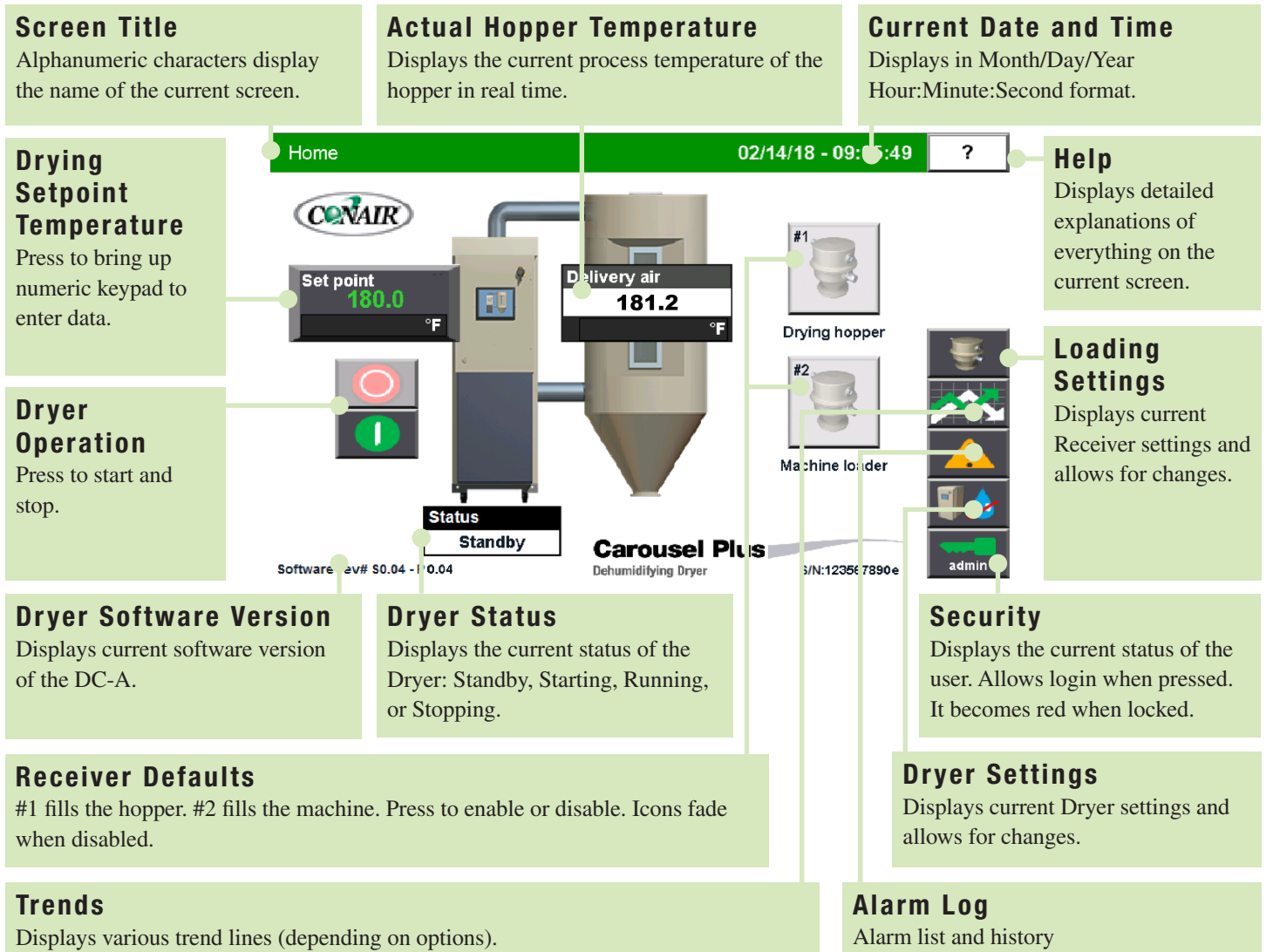

Control Function Flow Charts

The charts beginning on the next pages provide a quick summary of the control functions. For an explanation of each control function, see Control Function Descriptions.

NOTE: In the flow charts of the display screens that follow this page, the screens may display optional functions. If the options were not purchased with the dryer, those functions will not appear. Most options can be purchased and installed in the field.

NOTE: Upon startup, the first time loading each screen may be delayed slightly as the content is loaded. You may notice this mostly on the help screen.

Control Function Flow Charts (continued)

Home

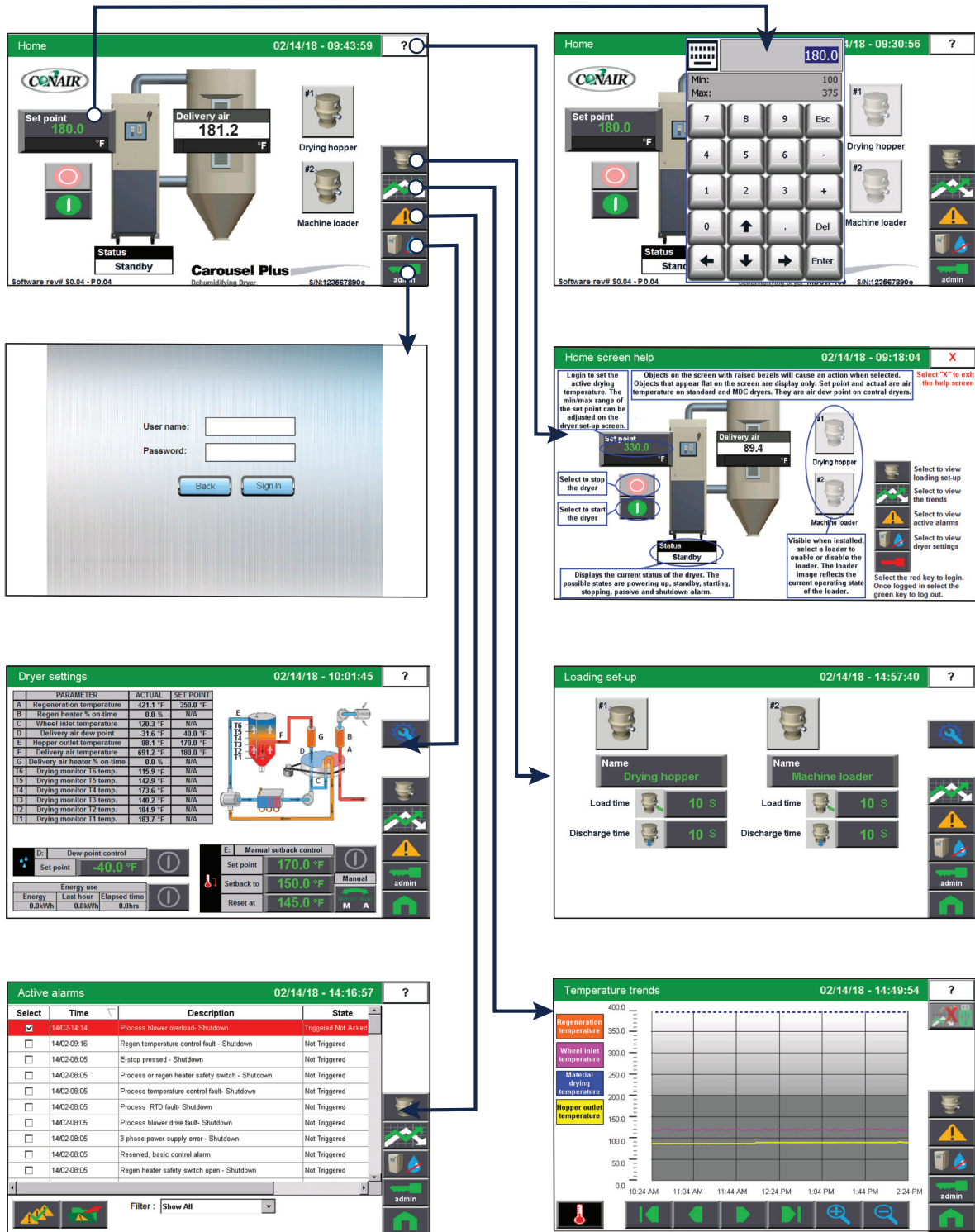

4b
Operation

Control Function Flow Charts (continued)

Loader Settings

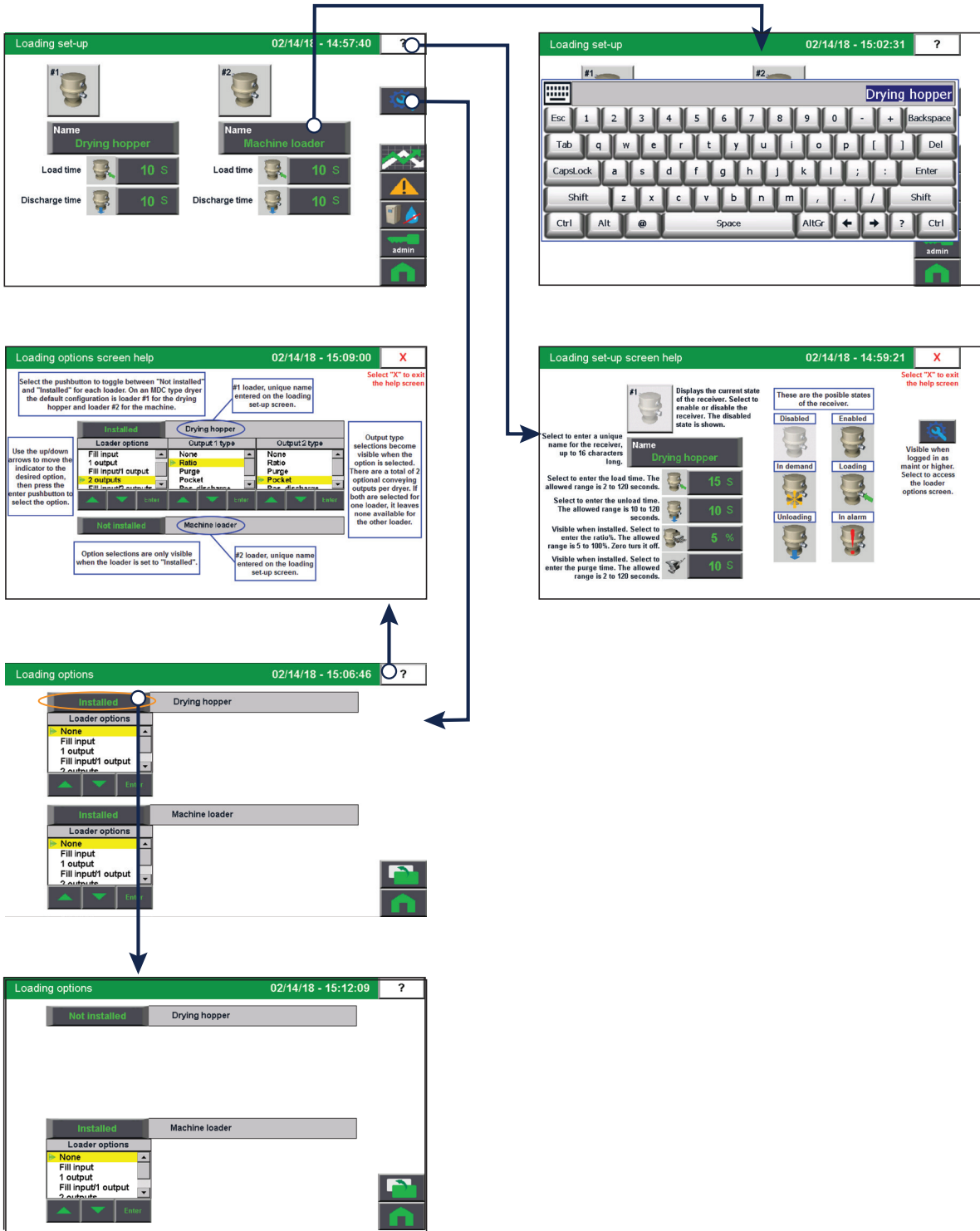

Control Function Flow Charts (continued)

Trends



Operation
4b

Control Function Flow Charts (continued)

Alarms

Active alarms 02/14/18 - 14:16:57 ?

Select	Time	Description	State
<input checked="" type="checkbox"/>	14:02:14.14	Process blower overload- Shutdown	Triggered Not Acked
<input type="checkbox"/>	14:02:09.16	Regen temperature control fault - Shutdown	Not Triggered
<input type="checkbox"/>	14:02:08.05	E-stop pressed - Shutdown	Not Triggered
<input type="checkbox"/>	14:02:08.05	Process or regen heater safety switch - Shutdown	Not Triggered
<input type="checkbox"/>	14:02:08.05	Process temperature control fault- Shutdown	Not Triggered
<input type="checkbox"/>	14:02:08.05	Process RTD fault- Shutdown	Not Triggered
<input type="checkbox"/>	14:02:08.05	Process blower drive fault- Shutdown	Not Triggered
<input type="checkbox"/>	14:02:08.05	3 phase power supply error - Shutdown	Not Triggered
<input type="checkbox"/>	14:02:08.05	Reserved, basic control alarm	Not Triggered
<input type="checkbox"/>	14:02:08.05	Regen heater safety switch open - Shutdown	Not Triggered

Filter: Show All

Active alarms screen help 02/14/18 - 14:19:40 X

Select "X" to exit the help screen

Select "X" to exit the help screen

Visible when installed, select to access the loading set-up

Select to view the trends

Select to view dryer settings

Select to login or logout

Select to return to the home screen

Select to acknowledge all alarms

Select to view the alarm history screen

The filter can be changed to "show all" to acknowledge previous alarms that are no longer active.

Alarm history 02/14/18 - 14:23:06 ?

From: 02/14/18 - 14:17:40 To: 02/14/18 - 14:22:40 Time span: 5 Mins Refresh

Time	Description	State	Name
14:02:14.18	Process blower overload- Shutdown	Not Triggered	Alarm SC08
14:02:14.18	Process blower overload- Shutdown	Triggered Ack	Alarm SC08

No USB present

Alarm history screen help 02/14/18 - 14:25:42 X

Select "X" to exit the help screen

Visible when installed, select to access the loading set-up

Select to view the trends

Select to view dryer settings

Select to login or logout

Select to return to the home screen

Select to move back 1 time span

Select to return to the active alarms screen

Select to move ahead 1 time span

Insert a flash drive into the usb port. When the status changes to "USB ready" press the pushbutton to save the alarm history to the flash drive in CSV format.

Alarm history 02/14/18 - 14:32:04 ?

From: 02/14/18 - 14:26:56 To: 02/14/18 - 14:31:56 Time span: 5 Mins Refresh

Time	Description	Name
------	-------------	------

1 Min
5 Mins
10 Mins
30 Mins
1 Hour
2 Hours
4 Hours
8 Hours
12 Hours
1 Day

No USB present

Control Function Flow Charts (continued)

Dryer Settings

Dryer set-up 02/14/18 - 10:19:35

Date and time: Year 2018, Month 2, Day 14, Hour 10, Minute 19, Second 35

Metric: English (°F & °C)

User password management: Current user: admin, Reset password

Energy calculator: Measured voltage: 460.0

Material drying temperature set point: Minimum 150.0 °F, Maximum 350.0 °F

Material residence time set point: Time: 4.0 hr

Dryer set-up screen help 02/14/18 - 10:22:32

Visible when the touch screen and PLC real-time clocks are synchronized.

Select to change between english and metric units of measure.

Select to set the allowable range of the delivery air temperature set point.

Visible when the dryer is in "Standby". Select to access optimizer set-up.

Visible when optimizer is installed. Select to access communications set-up.

Select to access alarm set-up.

Select to return to the previous screen.

Select to return to the home screen.

Custom users and passwords can be set up by a service representative. Select the "reset" push button to return the current logged in user password to the factory default.

Select to enter the actual measured supply voltage. Entering the actual voltage improves the accuracy of the energy calculation.

Visible when drying monitor is installed. Select to enter the desired residence time. This is the time at temperature to energize the material ready output.

Dryer set-up 02/14/18 - 11:03:38

Date and time: Year 2018, Month 2, Day 14, Hour 11, Minute 03, Second 38

Material drying temperature set point: Minimum 150.0 °F, Maximum 350.0 °F

Material residence time set point: Time: 4.0 hr

Dryer I/O test 02/14/18 - 10:35:39

PLC inputs	State	Local expansion inputs	State
Emergency stop UI-1/1	On	Receiver1 demand sensor UI-2/1	On
Regen blower aux. UI-1/2	On	Receiver1 fill sensor UI-2/2	On
Regen blower OL UI-1/3	On	Receiver2 demand sensor UI-2/3	On
Wheel rotation sensor UI-1/4	On	Receiver2 fill sensor UI-2/4	On
Isolation aux. UI-1/5	On	Conveying blower OL UI-2/5	On
Delivery air blower aux. UI-1/6	On	Delivery air filter sensor UI-2/6	On
Delivery air blower OL UI-1/7	On	Regen air filter sensor UI-2/7	On
Phase detection relay UI-1/8	On	Wheel inlet temp. RTD UI-2/8	On
Regen temperature RTD UI-1/9	On	Del. air dew point 4.20mA UI-2/9	On
Delivery air RTD UI-1/10	On	Ret. air dew point 4.20mA UI-2/10	On

PLC outputs: Delivery air blower DO-1/1, Delivery air SSRs DO-1/2, Wheel rot./regen blower DO-1/3, Isolation contactor DO-1/4, Regeneration SSRs DO-1/5, General Alarm DO-1/6

Local expansion outputs: Aftercooler sol. DO-2/1, Receiver select sol. DO-2/2, Conveying blower DO-2/3, Receiver sol. option-1 DO-2/4, Receiver sol. option-2 DO-2/4, Alarm horn DO-2/6

Note: The actual I/O available is dependent on the features purchased with the dryer.

Alarm set-up 02/14/18 - 14:07:16

Maintenance alert - hour meter settings:

- 40 Clean or replace del. air filter: 0:2
- 40 Clean or replace regen filter: 0:2
- 100 Clean after cooler coils: 0:2
- 900 Check regeneration heater: 0:2
- 900 Inspect desiccant wheel: 0:2
- 900 Check delivery air heater: 0:2

High dew point alarm set point: 0.0 °F

Load attempts alarm set point: 5

Drying monitor high and low temperature alarm set points at position:

Low alarm: 175.0 °F at T2

High alarm: 300.0 °F at T5

Communications set-up 02/14/18 - 11:05:35

HMI Ethernet: IP addr. 10.1.11.6, Subnet 255.255.0.0, Gateway 10.1.11.1

PLC Ethernet: IP addr. 10.1.11.6, Subnet 255.255.0.0, Gateway 10.1.11.1

Drying monitor communications: Online

Alarm set-up screen help 02/14/18 - 14:09:29

Independent hour meters are provided to generate maintenance alerts through the machine alarming system.

Select to enter the running hours between alerts.

Select to enter the dew point alarm set point. After 15 minutes of running, if the measured delivery air dew point is equal to or greater than this value, a passive alarm is triggered.

Visible when conveying is installed. Enter the number of load cycles that will cause an alarm. If the demand is not satisfied in that number of cycles, the alarm is not active until the demand has been satisfied once. Setting the value to zero disables the alarm.

Visible when drying monitor is installed. Low and high temperature alarms can be set at the same or different points in the drying hopper. Selecting the "at T" pushbutton changes the location in the drying hopper each time it's released. The available positions are T2 lowest, through T5 the highest position in the hopper. The alarms are passive.

Visible when optimizer is installed. Select to enter the hopper low alarm level. After the level has reached the operating level once, if the level drops below this value a passive alarm is triggered.

Auto start/stop set-up 02/14/18 - 13:49:49

Day	On/Off	Hour	Min
Monday	On	3:30	
Tuesday	On	3:30	
Wednesday	On	3:30	
Thursday	On	3:30	
Friday	On	3:30	
Saturday	On	3:30	
Sunday	On	3:30	

Day	On/Off	Hour	Min
Monday	Off	17:15	
Tuesday	Off	17:15	
Wednesday	Off	17:15	
Thursday	Off	17:15	
Friday	Off	17:15	
Saturday	Off	17:15	
Sunday	Off	17:15	

Auto start/stop set-up 02/14/18 - 14:03:39

Day	On/Off	Hour	Min
Monday	On	3:30	
Tuesday	On	3:30	
Wednesday	On	3:30	
Thursday	On	3:30	
Friday	On	3:30	
Saturday	On	3:30	
Sunday	On	3:30	

Day	On/Off	Hour	Min
Monday	Off	17:15	
Tuesday	Off	17:15	
Wednesday	Off	17:15	
Thursday	Off	17:15	
Friday	Off	17:15	
Saturday	Off	17:15	
Sunday	Off	17:15	

Auto start/stop set-up screen help 02/14/18 - 13:56:12

The auto start/stop set-up screens provides one dryer start event and one dryer stop event for each day of the week. Select the hour and the minute to enter the time of day for each individual day. Select the on/off push button to enable or disable each individual day. Select the main on/off push button for each function to enable or disable the entire auto start or stop function. The start and/or stop for any enabled day, only works when the auto start and/or stop function is enabled.

Select to enable or disable the entire function. Shows disabled.

Select to enable or disable the day. Shows enabled.

Select to enter the minute.

Select to enter the hour.

Operation 4b

Control Function Descriptions

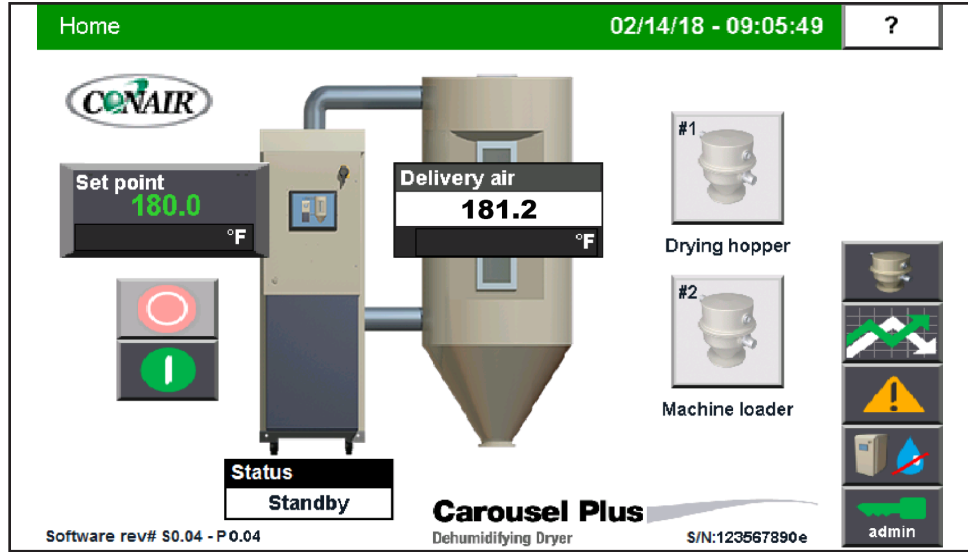

Home Screen

The home screen conveniently displays all information for typical operation. From here, you can view the current Actual temperature, set the Set point, view the dryer status, Start and Stop drying, and Start and Stop conveying. The Help screen will give you information to help with operating the dryer from this screen. The menu buttons on the right allow for navigation to other areas of the dryer control.

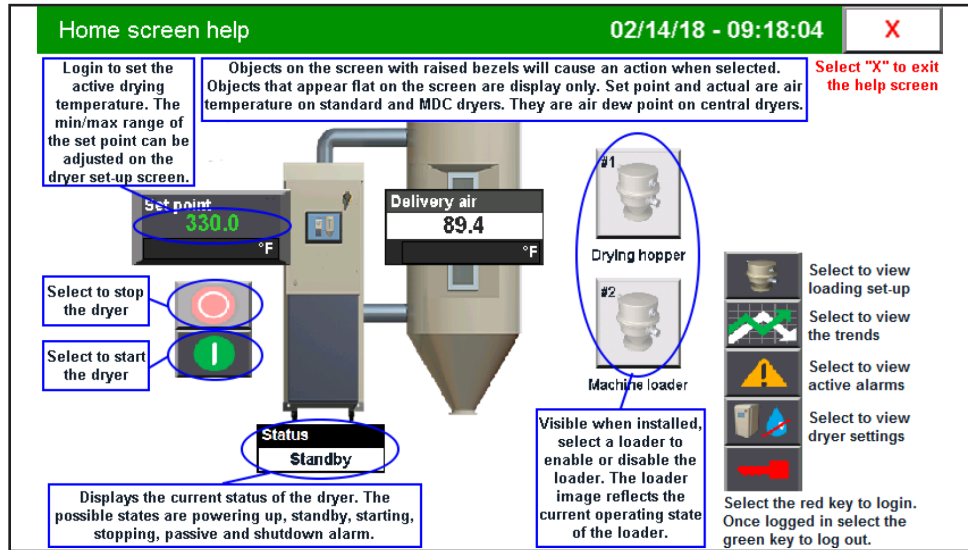

Help Screen – Home

This screen displays helpful information about the dryer home screen.

Control Function Descriptions



Number Pad Pop-up

This number pad will pop up when you've selected a setpoint or variable that can be adjusted. Enter your desired setting, followed by the enter key. Press the delete key (arrow left) to delete a number, or the ESC key to leave the number pad without making any changes.

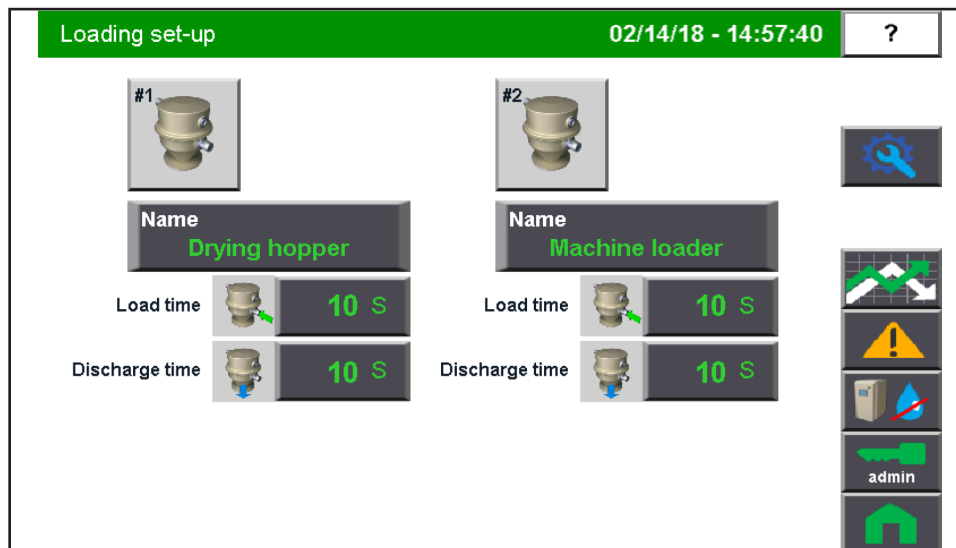

Loading Set-up Screen

This screen allows you to enable and disable loaders, and to change the loader names, load times, and discharge times. Pressing on the loader icon will enable and disable the loader. Pressing on the loader name box will allow for customizing the loader name. Pressing on the load time and discharge time boxes will allow for changes to the times (in seconds).

Control Function Descriptions

Loading set-up screen help
02/14/18 - 14:59:21
X

#1  Displays the current state of the receiver. Select to enable or disable the receiver. The disabled state is shown.

Select to enter a unique name for the receiver, up to 16 characters long.

Name
Drying hopper

Select to enter the load time. The allowed range is 2 to 120 seconds.



15 S

Select to enter the unload time. The allowed range is 10 to 120 seconds.



10 S

Visible when installed. Select to enter the ratio%. The allowed range is 5 to 100%. Zero turns it off.









5 %

Visible when installed. Select to enter the purge time. The allowed range is 2 to 120 seconds.



10 S

These are the possible states of the receiver.

Disabled	Enabled
	
In demand	Loading
	
Unloading	In alarm
	

Select "X" to exit the help screen

?

Visible when logged in as maint or higher. Select to access the loader options screen.

Help Screen – Loading Set-up

This screen will help with setup options on the Loading Setup screen. It notes limits to ranges and other important information.

The image shows a virtual alphanumeric keypad with a standard QWERTY layout. The keys include: Esc, numbers 1-0 with hyphen/underscore, left arrow, backspace, letters q-w, e-r, t-y, u-i, o-p, left bracket/right bracket, Del, letters a-s, d-f, g-h, j-k, l semicolon/apostrophe, right arrow, letters z-x, c-v, b-n, m comma/forward slash, up arrow, Ctrl, Alt, @, Space, ANGI, left arrow, right arrow, question mark, and Ctrl.

Alphanumeric Pad Pop-up





This keypad will pop up whenever an editable text box is pressed. This box allows for entering user names, passwords, loader names, etc. Press the Enter key once changes are made, or the ESC key to exit the screen without making changes.

4b-10 | Operation

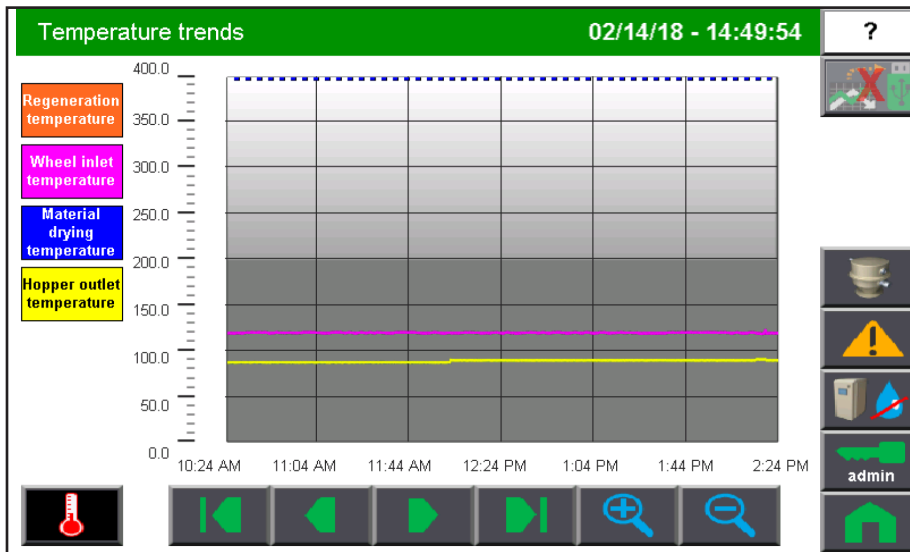
(Continued)

Control Function Descriptions



-  Temperature Trend
-  Heater On-Time % Trend
-  Dewpoint Trend
-  Drying Monitor Temperature Trend

Trend Screens

From these four screens, you can view the Temperature Trend, Drying Monitor Temperature Trend (if equipped), Heater On-Time % Trend, and Dewpoint trend. These trending screens can help you optimize performance, and note issues you may be having with your dryer.

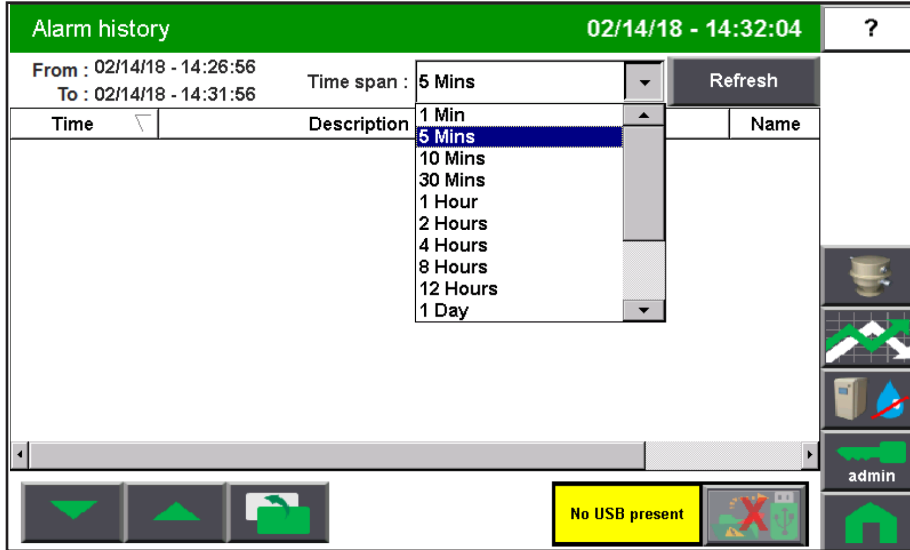

Alarm Log Screen

This screen displays the 100 most recent alarms. It allows you to navigate through the alarm list for more detail, acknowledge all alarms, and change alarm settings.

Control Function Descriptions

Active alarms screen help 02/14/18 - 14:19:40 X

Select "X" to exit the help screen

Press the word "Select" to check all listed alarms for acknowledgment or select them one at a time.

Press the word "Time" to change the sort order of the list of alarms.

Displays a list of active triggered alarms when the filter is set to hide not triggered. Displays a list of all active triggered and no longer active not triggered alarms when the filter is set to show all. Acknowledge and reset requires user login.

Visible when installed, select to access the loading set-up

Select to view the trends

Select to view dryer settings

Select to login or logout

Select to return to the home screen

Filter: Hide Not Triggered

The filter can be changed to "show all" to acknowledge previous alarms that are no longer active.

Select to reset/acknowledge all alarms

Select to view the alarm history screen

Help Screen – Alarm Log

This screen shows detailed help information for the Alarm Log Screen.

Alarm set-up 02/14/18 - 14:07:16 ?

Maintenance alert - hour meter settings				
40	Clean or replace del. air filter	0 : 2	00	
40	Clean or replace regen filter	0 : 2	00	
160	Clean after cooler coils	0 : 2	00	
960	Check regeneration heater	0 : 2	00	
960	Inspect desiccant wheel	0 : 2	00	
960	Check delivery air heater	0 : 2	00	

High dew point alarm set point

Delivery air dew point: 0.0 °F

#1 Load attempts alarm set point

Drying hopper: 5

#2 Load attempts alarm set point

Machine loader: 5

Drying monitor high and low temperature alarm set points at position

Low alarm	175.0 °F	at T2
High alarm	300.0 °F	at T5

Alarm Set-up Screen

From the Alarm Log Screen, pressing the Setup button takes you to this screen, where you can make adjustments to the user settings which trigger an alarm condition or maintenance alerts.

✓ 09/11-16:27 E-stop or high temp - Shutdown Triggered N

Alarm Banner

The alarm banner will appear on the screen in the event of an alarm that needs addressed by the operator. The banner will give a description of the problem, and the type of alarm. The alarm can be acknowledged here, and the banner can be closed. You can also view the alarm list on the Alarm page.

Control Function Descriptions

Dryer settings 02/14/18 - 10:01:45 ?

	PARAMETER	ACTUAL	SET POINT
A	Regeneration temperature	421.1 °F	350.0 °F
B	Regen heater % on-time	0.0 %	N/A
C	Wheel inlet temperature	120.3 °F	N/A
D	Delivery air dew point	-31.6 °F	-40.0 °F
E	Hopper outlet temperature	88.1 °F	170.0 °F
F	Delivery air temperature	691.2 °F	180.0 °F
G	Delivery air heater % on-time	0.0 %	N/A
T6	Drying monitor T6 temp.	115.9 °F	N/A
T5	Drying monitor T5 temp.	142.9 °F	N/A
T4	Drying monitor T4 temp.	173.6 °F	N/A
T3	Drying monitor T3 temp.	140.2 °F	N/A
T2	Drying monitor T2 temp.	184.9 °F	N/A
T1	Drying monitor T1 temp.	183.7 °F	N/A

D: Dew point control [On/Off]

Set point: **-40.0 °F** [On/Off]

Energy use		
Energy	Last hour	Elapsed time
0.0kWh	0.0kWh	0.0hrs

E: Manual setback control [On/Off]

Set point: **170.0 °F** [On/Off]

Setback to: **150.0 °F** [Manual]

Reset at: **145.0 °F** [M A]

NOTE: Shown with all options. Your screen may be different.

Dryer Settings Screen

This screen allows you to make changes to some of the dryer settings, and to navigate to the Dryer Setup Screens (if logged in at the appropriate security level). This screen will vary depending on the installed features.

Dewpoint control can be turned on/off and adjusted here. The Energy Meter can be turned on/off here and will display a value so that you can make changes to improve energy consumption.

This screen also allows for making adjustments to Setback Control settings. When enabled, the Setback Control will set the material drying temperature back to the “Setback to” value when the air temperature exiting the drying hopper reaches the Setpoint value for 5 minutes. When the air temperature exiting the drying hopper reaches the “Reset at” set point for 2 minutes, the material drying temperature returns to the original value.

In Manual mode, all set points are entered manually, based on your experiences. In Auto mode, the “Setback to” and “Reset at” values are calculated. Select the on/off push button to turn the control on or off. Select the M/A arrow button to switch between Manual and Auto modes.

When Dewpoint control is active, flashing text stating “Dewpoint Control Active” will appear to the right of the drying wheel in the graphic on this screen. When Clean Cycle is active, flashing text stating that “Clean Cycle Active” will appear to the right of the drying wheel in the graphic on this screen. Clean Cycle occurs after every 24 hours of accumulated run time. When Clean Cycle is active, you will notice that the regeneration temperature increases. This is normal. Refer to the Help screen for more information.

NOTE: For a resin (with “predictable properties”) such as Polypropylene (PP), running in Auto mode should work fine. When using another resin [e.g., polyethylene terephthalate (PET)] where there is “less operating history”, running in Manual mode may be advisable until one is confident with the performance of the dryer in drying this resin.

Control Function Descriptions

Dryer settings screen help 02/14/18 - 10:09:08 X

The letters in the diagram indicate the location of the listed parameters in the drying system. Select "X" to exit the help screen

PARAMETER	ACTUAL	SET POINT
A Regeneration temperature	409.2 °F	350.0 °F
B Regener heater % on-time	N/A	N/A
C		
D		
E		
F		
G		
T6 Drying monitor T6 temp.	171.4 °F	N/A
T5 Drying monitor T5 temp.	187.1 °F	N/A

The list of dryer parameters is displayed only. The size of the list will vary depending on the installed features.

The set-up push button is visible when logged in as maint or higher. Select to access dryer set-up.

When enabled, dew point control varies the regeneration temperature of the wheel to maintain the desired delivery air dew point. Select the on/off push button to enable or disable the control.

When enabled, the setback control will set the delivery air temperature to the "Setback to" value when the hopper outlet temperature reaches the "Set point" value for 5 minutes.

Select to enable/disable setback control.

Select to use manual or auto calculated set points.

When enabled, the energy meter displays the calculated energy use. The last hour value can be monitored to see if recent changes have improved or worsened energy consumption.

When the hopper outlet temperature reaches the "Reset at" value for 2 minutes, the delivery air temperature returns to the original value.

Help Screen– Dryer Settings

This screen gives detailed information to help you adjust the settings on the Dryer Settings Screen.

Dryer set-up 02/14/18 - 10:19:35 ?

Date and time

Year: 2018

Month: 2

Day: 14

Hour: 10

Minute: 19

Second: 35

English Metric

°F °C

User password management

Current user: admin

Reset password

Energy calculator

Measured voltage: 460.0

Material drying temperature set point

Minimum: 150.0 °F

Maximum: 350.0 °F

Material residence time set point

Time: 4.0 hr

Dryer Set-up Screen

This screen may vary depending on the installed features. This screen allows for the Auto Start function to automatically start the dryer at a desired time. Enter the day of the month (1-31), the hour of the day (1-24), and the minutes of the hour (0-59) and turn on the function. After starting, the Auto Start automatically resets to off or disabled. The Material Drying Minimum and Maximum setpoints can also be set on this screen. The range set at the factory is 100°F to 375°F {37.7-190.5°C}. The Reset Password box is only visible when logged in as an Administrator. Select it to reset a user's password to a new password, when the old password is unknown. Select Change Password to change the password of the user currently logged in. The HMI and PLC Ethernet settings are display only information. Select the "Close Runtime" button only if you wish to exit the HMI operating system. Press the arrow button to navigate to the I/O test screen.

Control Function Descriptions

Dryer set-up screen help 02/14/18 - 10:22:32 X

Select "X" to exit the help screen

Visible when the touch screen and PLC realtime clocks are synchronized.

Select to change between english and metric units of measure.

Select to set the allowable range of the delivery air temperature set point.

Visible when the dryer is in "Standby". Select to access I/O test.

Select these set points to enter the date and time for the touch screen's realtime clock.

User password management

Current user: admin

Reset password

Material drying temperature set point

Minimum: 150.0 °F

Maximum: 350.0 °F

Visible when optimizer is installed. Select to access optimizer set-up.

Energy calculator

Measured voltage: 460.0

Select to access communications set-up.

Material residence time set point

time: 4.0 hr

Select to access auto start/stop set-up.

Select to access alarm set-up.

Custom users and passwords can be set-up by a service representative. Select the "reset" push button to return the current logged in user password to the factory default.

Select to enter the actual measured supply voltage. Entering the actual voltage improves the accuracy of the energy calculation.

Visible when drying monitor is installed. Select to enter the desired residence time. This is the time at temperature to energize the material ready output.

Select to return to the previous screen.

Select to return to the home screen.

Help Screen – Dryer Set-up

This screen gives detailed information to help you adjust settings on the Dryer Setup Screen.

Dryer I/O test 02/14/18 - 10:35:39 ?

PLC inputs	State	Local expansion inputs	State
Emergency stop UI-1/1	●	Receiver1 demand sensor UI-2/1	●
Regen blower aux. UI-1/2	○	Receiver1 fill sensor UI-2/2	○
Regen blower OL UI-1/3	○	Receiver2 demand sensor UI-2/3	●
Wheel rotation sensor UI-1/4	●	Receiver2 fill sensor UI-2/4	○
Isolation aux. UI-1/5	●	Conveying blower OL UI-2/5	○
Delivery air blower aux. UI-1/6	○	Delivery air filter sensor UI-2/6	○
Delivery air blower OL UI-1/7	○	Regen air filter sensor UI-2/7	○
Phase detection relay UI-1/8	●	Wheel inlet temp. RTD UI-2/8	●
Regen temperature RTD UI-1/9	●	Del. air dew point 4-20mA UI-2/9	●
Delivery air RTD UI-1/10	●	Ret. air dew point 4-20mA UI-2/10	●

PLC outputs	Local expansion outputs
<ul style="list-style-type: none"> Delivery air blower DO-1/1 Delivery air SSRs DO-1/2 Wheel mtr./regen blower DO-1/3 Isolation contactor DO-1/4 Regeneration SSRs DO-1/5 General Alarm DO-1/6 	<ul style="list-style-type: none"> Aftercooler sol. DO-2/1 Receiver select sol. DO-2/2 Conveying blower DO-2/3 Receiver sol. option-1 DO-2/4 Receiver sol. option-2 DO-2/4 Alarm horn DO-2/6

Note: The actual I/O available is dependent on the features purchased with the dryer.

Dryer I/O Test Screen

This screen allows for testing of various outputs of your dryer. To turn on an output, use the up/down arrow buttons to move the yellow indicator to the output you wish to energize. Press the Enter button to select the output. Once selected, press and hold the On/Off push button to energize the output. Release the On/Off push button to turn the output off.

NOTE: After selecting an output with the up/down arrow, you must press enter to finish the selection prior to testing that output.

Control Function Descriptions

Dryer I/O test screen help 02/14/18 - 10:37:13 X

Select "X" to exit the help screen

A green digital input state indicates contact closed. The grey state indicates contact open.

A green analog input state indicates no errors. The grey state indicates the input has errors. An analog error could be an open circuit, short circuit or out of range signal.

Visible when drying monitor is installed. Select to goto the remote I/O test screen

Select to return to the dryer set-up screen.

Select to return to the home screen.

The yellow highlight indicates the current selected output.

Press and hold the on/off push button to energize the selected output. Release the push button to de-energize the output.

Use the up/down arrows to move the indicator to the desired output, then press the enter pushbutton to select the output.

Selection indicator

Local expansion inputs

Input	State
Receiver1 demand	Green
Receiver1 fill sens	Green
Receiver2 demand	Green
Receiver2 fill sens	Green
Conveying blower	Green
Delivery air filter sensor UI.2/8	Green
Regen air filter sensor UI.2/7	Green
Wheel inlet temp. RTD UI.2/8	Green
Del. air dew point 4.20mA UI.2/9	Green
Hot. air dew point 4.20mA UI.2/10	Green

Local expansion outputs

Output	State
Alert/alarms sol. DO.2/1	Grey
Receiver sol. option 1 DO.2/4	Grey
Receiver sol. option 2 DO.2/4	Grey
Alarm horn DO.2/6	Grey

PLC outputs

Output	State
Delivery air blower blower DO.1/1	Green
Delivery air SSRs DO.1/2	Green
Wheel inr./regen blower DO.1/3	Green
Isolation contactor DO.1/4	Green
Regeneration SSRs DO.1/5	Green
General Alarm Blower	Green

Help Screen – Dryer I/O Test

This screen provides detailed descriptions of how to use the Dryer I/O Test functionality of the control.

Highest permission

ADMIN

SUPER

MAINT

Lowest permission

OPER

No security enabled



Security Login Pop-up

This page pops up after pressing the Security Key button to log in as a user. After logging in (see table below for login information), the Security Key button will display the current login level of the user.

Level	User	Password	Password Editable
1 (Low)	oper	oper	No
2	maint	maint	Yes
3	super	super	Yes
4 (High)	admin	admin	Yes + reset

To Start Drying

- 1 Make sure there is material in the hopper.
- 2 Turn on the main power to the dryer. Make sure the dryer's disconnect dial is in the ON position. This powers up the control.
- 3 Set the drying temperature. Press the Setpoint Temperature button, then adjust the Setpoint. Enter the temperature on the numeric keypad and press enter.

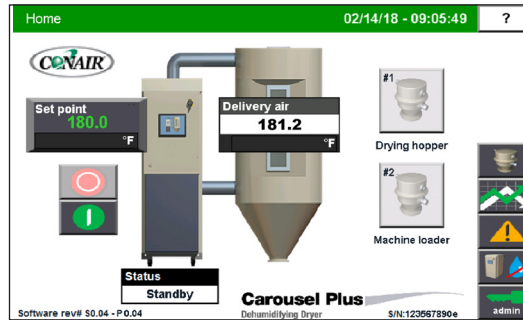
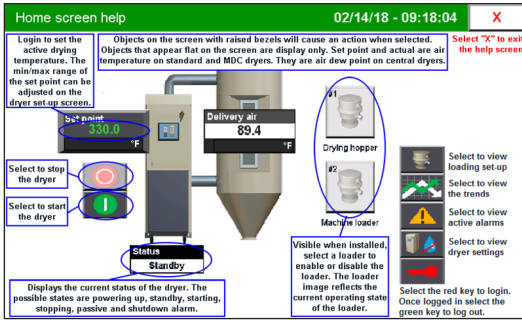
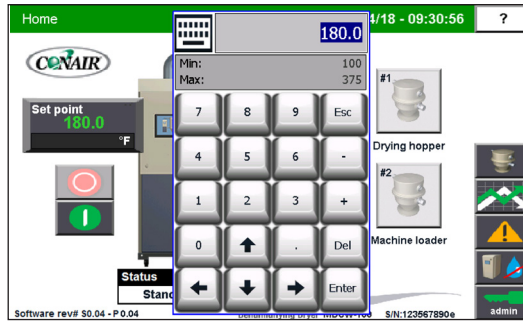
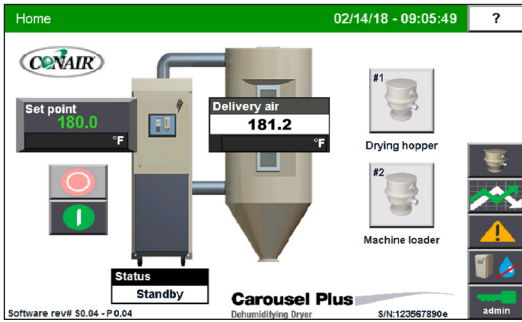
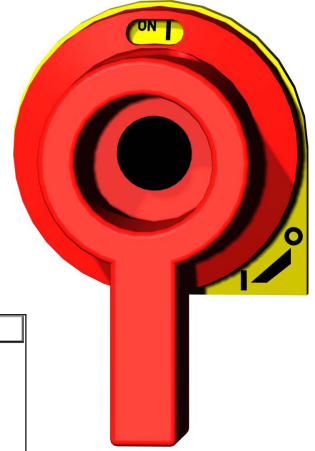

4 Press the START button.

If everything is installed correctly:

- The start button will fade.
- The process and regeneration blowers turn on.
- The process and regeneration heaters turn on.
- The status bar will display "Starting".
- After the heaters turn on, the status bar will display "Running".

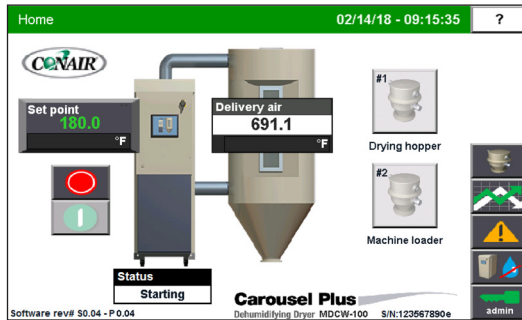

To Stop Drying

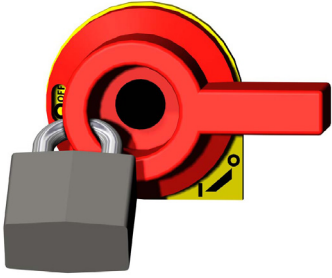

- 1 Press the STOP button.
 - The blowers continue running for a few minutes to cool the heaters.
 - The status bar will display “Stopping”.
- 2 Be sure to disconnect and lockout the main power if you have stopped the dryer to perform maintenance or repair.

IMPORTANT: Do not use the main power switch to stop the dryer. Turning off power to the control and dryer during normal operation prevents the necessary cool-down period, and can trigger the shutdown/high temperature alarm during your next drying cycle.



CAUTION:

Improper shut down can cause damage to your dryer.

Using the Loading Function on the Hopper Loader (optional)

- 1 Connect the conveying hose and/or pick-up wand from the material source to the inlet on the hopper loader.
- 2 Connect a clean, dry compressed air source supplying 80 psi of compressed air to the threaded coupling on the side of the dX dryer.
- 3 Set the Loader settings.
- 4 Press the Loader button.
- 5 Set the load and discharge times.

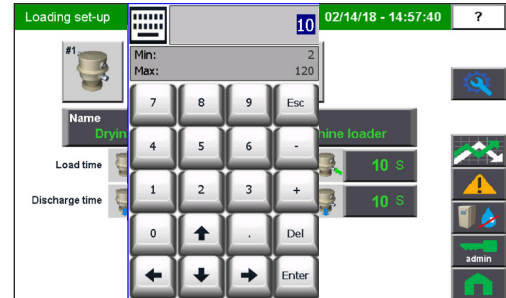
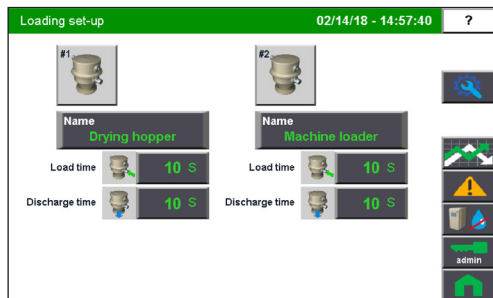
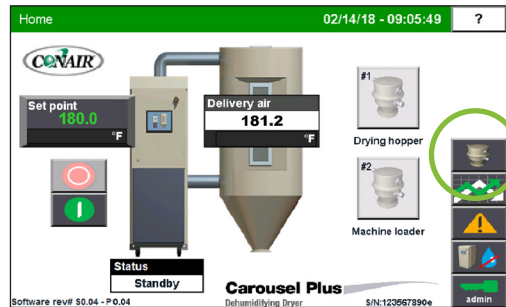

- 6 Adjust the hose connection on the pick-up wand to cover the number of holes to maximize the material flow.
- 7 Press the Loader icon on the home page and turn on loading for each Loader.

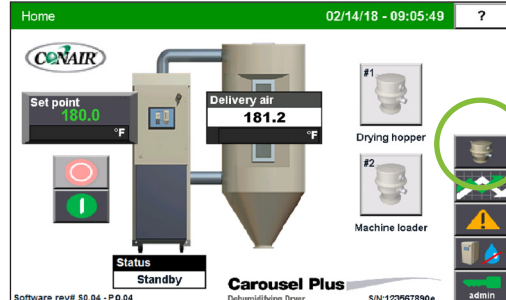

Note: If your loading system is configured for ratio, a percentage adjustment field will display here.

Machine Loader Conveying

- 1 Move the dX to the processing machine.** Lock the wheels and connect the main power source. Connect the water source if you have an aftercooler. Connect compressed air if the self-loading option is being used.
- 2 Mount the vacuum receiver on the feed throat.** Push the vacuum receiver onto the mounting bracket.
- 3 Place the appropriate material insert inside the distribution box.**



- 4 Make sure all hoses are connected securely.**
- 5 Adjust the demand sensor.** Position the sensor at the lowest level of material that you want to maintain in the viewing chamber before another load cycle begins. Make sure the sensor rests against the sight glass.
- 6 Set the load time.**
- 7 Start conveying.** Turn the “Loader” ON.

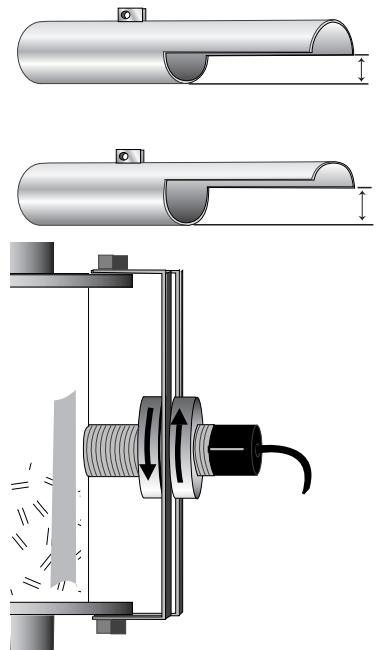

How to Log In

Level	User	Password	Password Editable
1 (Low)	oper	oper	No
2	maint	maint	Yes
3	super	super	Yes
4 (High)	admin	admin	Yes + reset

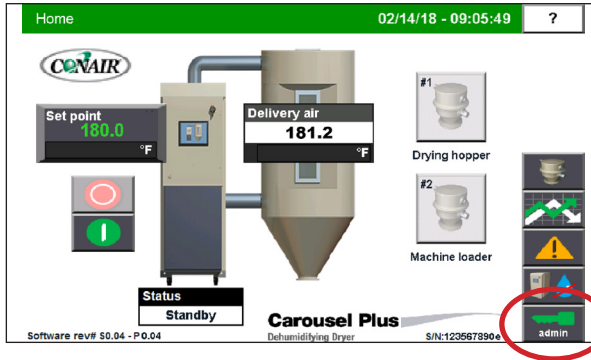

1 Select the key to login.



NOTE: After login is completed, the user-level will be displayed on the button.

Using the Auto Timer

You can set the dryer to start automatically using the Auto Start function. The supervisor password is necessary to use this function.

Programming Auto Start

The Auto Start function can be programmed from the Auto start/stop set up screen. This button can be accessed by pressing the Auto start/stop set-up button from the Dryer Setup screen which is accessed by pressing the Dryer Setup button from the home screen.

Once the Auto Start has been programmed dryer will automatically start at the set time.

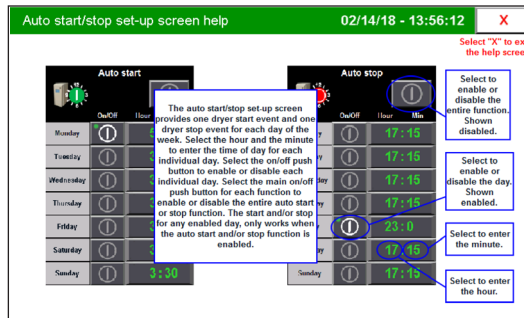
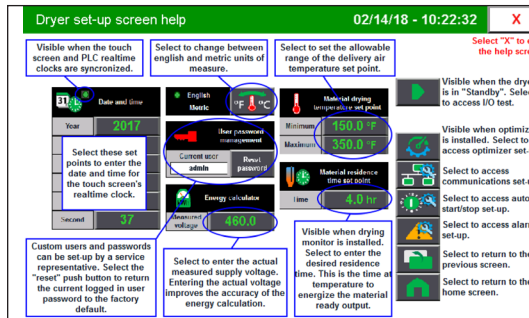
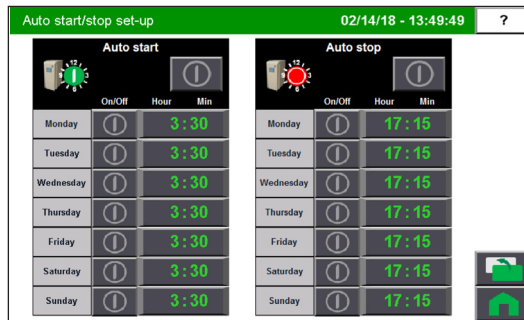
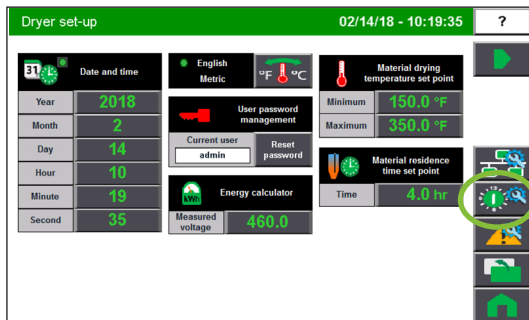

NOTE: Conair is not responsible for damage caused by excessively high drying setpoints that are not in accordance with your drying material recommendations.

NOTE: Software may allow the process temperature setpoint limit up to 450°F {232°C}; however, Conair does not recommend a setpoint limit over 375°F due to nuisance alarms.

NOTE: To avoid nuisance alarms Conair recommends that the low setpoints be set to 150°F {66°C} or above.

Setting High Setpoint Limits

You can protect your drying process by preventing someone from entering process temperatures above or below an acceptable level for the material. You can also set the high and low limits equal to the process temperature to prevent accidental or unauthorized changes to the setting during operation. Users must be logged in with the appropriate user level to change these settings.

- 1 Turn on the main power to the dryer.
- 2 Press the dryer setup button on the home screen.
- 3 Then set the minimum and maximum drying temperature setpoint.

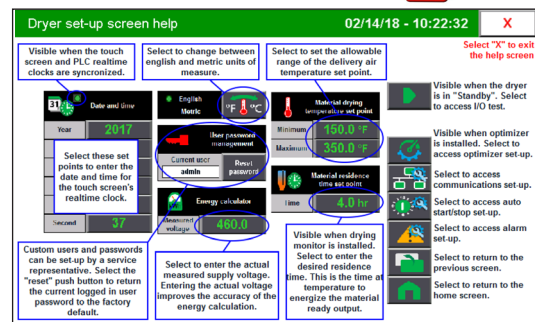
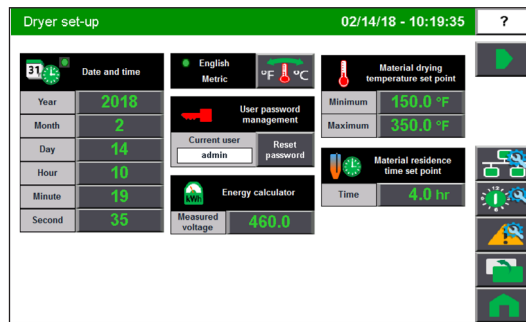

Using Dewpoint Control

Note: Make sure your setback temperature is approximately 40° F above your return air temperature when using this feature.

Your dryer is equipped with a dewpoint monitor and dewpoint control features. You can choose to use it as a monitor only device, or to maintain a steady dewpoint that you select with the dewpoint control. Dewpoint control will vary the regeneration air temperature to condition the desiccant to the level necessary to maintain the desired dewpoint.

Dewpoint Control

NOTE: The supervisor's password is necessary.

NOTE: When Dewpoint Control is active, "Dewpoint Control Active" text will flash to the right of the drying wheel graphic on the Dryer Settings screen.

- 1 From the home screen, select "Dryer Setup" to get to the "Dryer Setup screen".
- 2 Press the arrow navigation button on the dryer setup screen to view the Dryer Settings screen.
- 3 Adjust the Dewpoint Control setpoint by pressing the text block.
- 4 Turn Dewpoint Control on or off by pressing the  button.

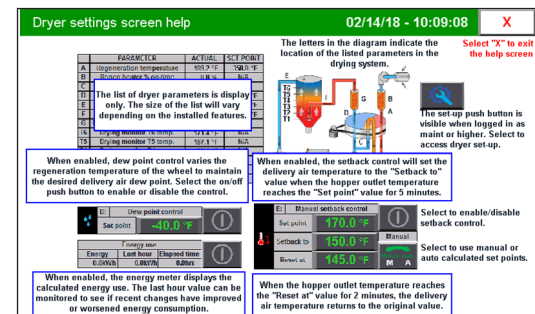
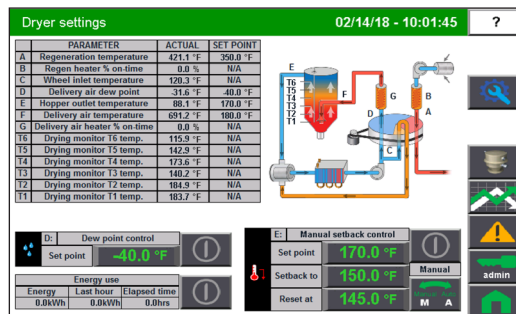

Using the Energy Use Monitor

- 1 From the home screen, select “Dryer Setup” to get to the “Dryer Setup Screen”.
- 2 Press the arrow navigation button to navigate to the Dryer Settings Screen.
- 3 Turn Energy Use monitoring on or off by pressing the  button.

Using the Setback Feature

The DC-C Control comes standard with setback installed, but disabled. You can choose to set the mode to “Off”, “Auto”, or “Manual”. Refer to the Control Function Descriptions later in this section for more detailed information.

This feature is designed to save you money on energy costs and help to keep you from over drying your material.

This is how setback operates when the control setback mode is set on Temperature.

The control monitors the temperature of the air exiting the drying hopper. If that temperature reaches a customer-entered setpoint, the delivery process air temperature will automatically setback to a customer-entered setpoint. Then, if the air exiting the drying hopper drops below the customer-entered temperature an amount greater than what is desired, the process temperature will automatically reset back to the original value.

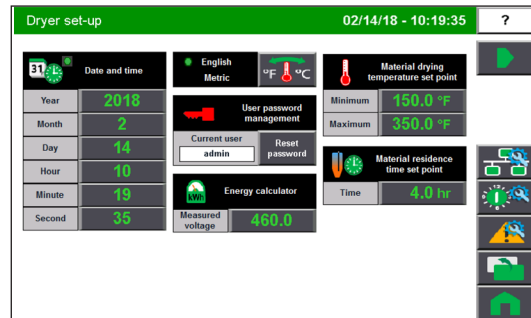

To Activate Setback:

- 1 From the home screen, select “Dryer Setup” to get to the “Dryer Setup Screen”.
- 2 Press the arrow navigation button to navigate to the Dryer Settings Screen.
- 3 **Set the Setback settings.** Set the setback process temperature. This is the setpoint at which the process temperature will go to once the control goes into setback. The actual temperature on the default screen will still show the actual temperature measured at the hopper inlet. The setpoint shown on the default screen will still show the original setpoint. The word “Setback” will appear on the Actual Temp.

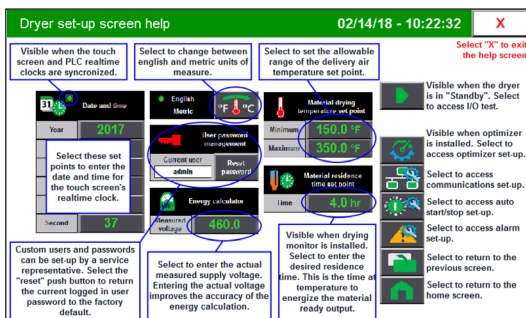

Setback Feature Guidelines

Careful selection of setpoint values in these functions is necessary for the setback to operate properly. The following table is only a guideline of recommended settings for these setpoints. It will be necessary for each customer to determine the best setpoints for their application based on experience.

Normal Drying Temp	Setback Return Temp	Setback Temp (Process)
160° F {71° C}	120° F {49° C}	150° F {66° C}
240° F {116° C}	135° F {57° C}	180° F {82° C}
300° F {149° C}	160° F {71° C}	200° F {93° C}
340° F {171° C}	180° F {82° C}	220° F {104° C}

A recommended way to determine the “Setback” setpoint is to monitor the actual temperature of this function during pre-drying of your material at start-up, and while running at your normal maximum material throughput. The “Setback” setpoint should be set 10 to 20° above maximum temperature noted in these situations.

The “Setback” setpoint you select should be adequate to reduce the temperature significantly enough to prevent over-drying of your material. However, keep in mind that the cooler the temperature selected, the longer it will take for the material to heat back up to its proper drying temperature once the dryer comes out of Setback mode.

When drying at low temperatures (for example 160 - 180° F {71 - 82° C}), you are able to setback the temperature only a small amount. The “Setback Temperature (Process)” should not be set lower than 150° F {66° C}, even if the control will allow it. It is very likely the dryer will not be able to achieve low temperatures without adding additional cooling to the process air circuit. The maximum achievable setpoint is dependent on the temperature of the return air coming back to the dryer. As the return air temperature climbs, the temperature that the dryer is capable of controlling at climbs. For example, if the return air to the dryer is 110° F {43° C}, the dryer may not be able to control at a “Setback” setpoint below 150 - 155° F {66 - 68° C}.



NOTE: Selecting too low of a setpoint may result in nuisance Process Temperature Loop Break alarms if the dryer is not able to achieve this setpoint.

Setback Auto vs Manual Mode

Typically, the Auto Setback mode will be used in most instances. The Manual Mode is available for operators who want to set specific ranges for Setback operation. In Auto mode, these temperatures are calculated by the dryer.

Material Recipe Screens

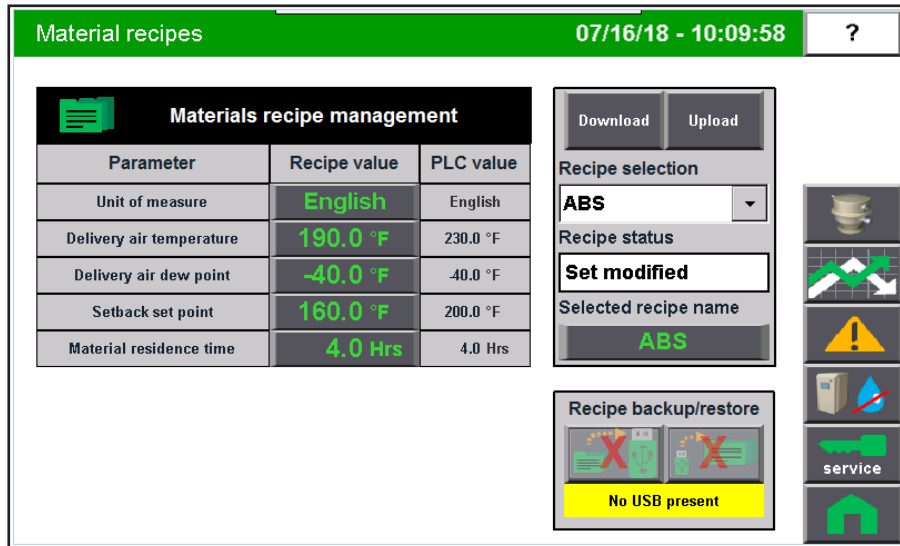

Recipe Screen

Access the recipe page from the main screen, using the Recipe button. Operators can use the Recipe page to quickly use a material recipe for drying parameters. From this screen, you can also upload values to create or modify a recipe. Users logged in as “Admin” can modify the names of recipes with custom names. Recipes can be saved to a USB drive or restored from a USB drive using the control on this screen.

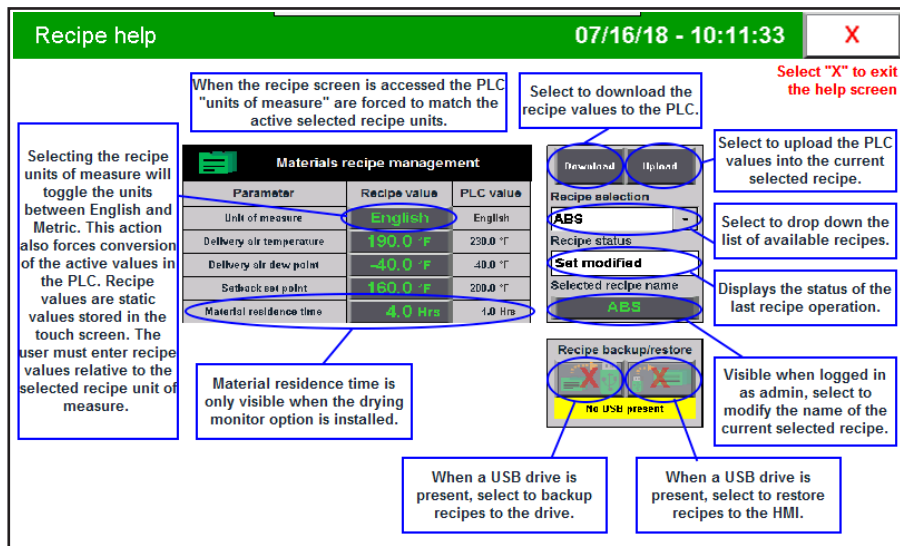

Recipe Help Screen

Use the Help screen (press the ?) to access detailed help information about each field on the screen.

Automatic Cleaning Cycle

In order to maintain dryer efficiency, the DC-C Control initiates a Cleaning Cycle for the drying wheel after every 24 accumulated hours of run time. During this period, you will see “Clean Cycle Active” text flash to the right of the drying wheel graphic on the Dryer Settings screen.

During Clean Cycle operation, you will notice that the regeneration temperature increases, in order to properly clean the dryer and ensure optimal operation. This is normal. This Clean Cycle will not affect material drying, still allows changes to be made to the drying process, and will last anywhere from one hour to two hours, depending on your current drying temperature when the Clean Cycle initiates. If the dryer is stopped or turned off during the Cleaning Cycle, the Cleaning Cycle will stop and immediately resume when the dryer is re-started.

Maintenance

Preventative Maintenance Schedule	5-2
Checking the Dewpoint	5-3
Cleaning the Hopper	5-3
Clean the Process Filter	5-4
Cleaning the Regeneration Filters	5-5
Cleaning the Conveying Filter.....	5-6
Cleaning the Vacuum Receiver.....	5-7
Screen Filter Cleaning (optional)	5-8
Cleaning the Compressed Air Filter (optional)	5-9
Cleaning the Optional Water-to-Air Aftercooler Coils	5-9
Cleaning the Precooler Coils	5-10
Inspecting Hoses and Gaskets.....	5-10
Cleaning and Servicing the Desiccant Rotor	5-11

Preventative Maintenance Schedule

Routine maintenance will ensure optimum operation and performance of the dX Dryer and the receiver on the hopper. We recommend the following maintenance schedule and tasks.

- **Whenever you change materials**
 - Drain and clean the hopper.**
- **Weekly or as often as necessary**
 - Clean or replace the process, regeneration and conveying filters.**
You may need to clean filters more often than weekly. Frequency depends on how much material you process and how dusty or full of fines it is.
 - Inspect hoses and hose connections.**
Check for damage, kinks, or loose hose clamps. Replace any hoses that show signs of damage or wear. Reposition and tighten loose hose clamps.
 - Clean and check the filter for clogging or holes.***
Replace if necessary.
 - Drain the compressed air filter trap (if equipped).***
Depending on your compressed air system, you may see moisture or oil in the compressed air filter trap. Open the petcock on the bottom of the trap to drain.
- **Monthly, or as often as necessary**
 - Clean the aftercooler and/or optional precool coils.**
You may need to clean the coils more often than monthly. Frequency will depend on the type and volume of material you process.
 -  **NOTE:** Signs of contamination may indicate need for volatile trap. Contact Conair Parts for assistance.
 - Check the seals of the vacuum sequencing valve, optional ratio valve and discharge valve pan***
 - Inspect gaskets for damage or wear.**
Damaged gaskets can allow moisture to seep into the closed-loop drying system. Replace any gasket that is torn or cracked.

IMPORTANT: The ability for moisture to get through to where it is unwanted can be an important factor in dryer performance. More frequent change out can be important especially if a variety of resins are being processed.
- **Every six months or as often as necessary**
 - Verify dewpoint readout and performance with calibrated portable instrument.**
 - Measure current draw on all 3 legs of heater wires.**
This is to ensure that the heater is working properly.
 - Examine the bolts.**
Examine the bolts or clips holding the loader to the surface. Make sure the bolts or clips are tight.*
 - Inspect Dessicant Rotor and Return Air Ducting for signs of contamination.**
Clean or replace Dessicant Rotor if there are any signs of contamination. Consider adding a Volatile Trap.

Contact Conair Parts and Service
(800) 458 1960
From outside of the United States, call:
(814) 437 6861

* Procedures marked with an asterisk are steps to follow for the receiver located on top of the hopper.

Checking the Dewpoint

It is a good idea to monitor the dewpoint performance of your dryer periodically with a calibrated portable dewpoint monitor, to ensure it is performing at maximum capacity. Even if your dryer has a dewpoint readout, comparing it to a portable instrument periodically will confirm that the dewpoint sensor and readout is performing properly.

To check dewpoint on models dX 15-100:

- 1 Connect your portable dewpoint meter to the dewpoint check port of the dryer.**
- 2 Turn on the portable instrument**, and ensure there is positive airflow through the sensor.
- 3 Monitor the readout** and allow ample time for it to stabilize before disconnecting it. Some dewpoint monitors require a substantial amount of time for residual moisture to be purged from the sensor.
- 4 In the event the dewpoint is not satisfactory**, *refer to the Troubleshooting section of the manual* under Process Dewpoint alarm.

 **NOTE:** Portable dewpoint monitors purchased from Conair were provided with a male connector that plugs into the dewpoint check port. If you purchased your portable instrument elsewhere, the male connector is available through the Conair parts department.

Cleaning the Hopper



CAUTION: Hot Surfaces

Always protect yourself from hot surfaces inside the dryer and hopper.

The hopper, spreader cone, and discharge assembly should be cleaned thoroughly between material changes to prevent resin contamination.

- 1 Close the hopper slide gate.**
- 2 Drain the remaining material into a bucket.**
- 3 Remove the spreader cone.** Open the hopper door. Reach into the hopper. Grasp the spreader cone tube, lift up slightly, twist and then push down to release it. Tilt the cone assembly and pull it out through the hopper door.
- 4 Clean the spreader cone and the inside of the hopper.** Make sure you also clean the return air screen at the return air outlet of the hopper.
- 5 Repeat the steps in reverse order to reassemble the hopper** before adding material.





Clean the Process Filter

Clogged filters reduce air flow and dryer efficiency. Cleaning frequency depends on how much material you process and how dusty or full of fines it is. This may be affected by the type of resin you are using. For example, a PET resin could produce more dusts and fines than PP. You will know, based on the resins being processed and the amount of material to be processed, how frequently the process filter needs to be either cleaned or replaced.



CAUTION: Hot Surfaces

Always protect yourself from hot surfaces inside and outside the dryer and drying hopper.

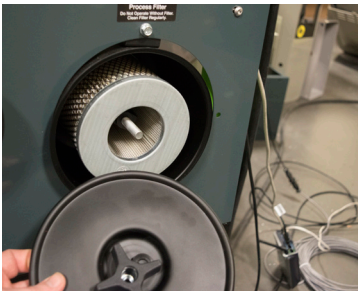

- 1 Shut down the dryer, disconnect and follow lockout procedures.**
- 2 Allow the dryer to cool – surfaces may be hot.**
- 3 Locate the Process filter on the front of the dryer. It has a label identifying it.**
- 4 Unscrew the hand knob, being careful not to lose the rubber washer between it and the filter housing lid.**
- 5 Remove the filter housing lid, allowing access to the process filter.**

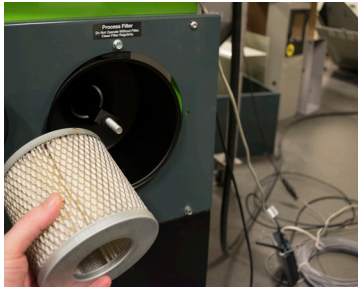

- 6 Remove the process filter from the filter housing by pulling straight out.**
- 7 Clean or replace the filter.**
- 8 Wipe the inside of the filter housing clean, then replace the filter cartridge into the housing.**



- 9 Place the housing lid and rubber washer onto the bolt.**



- 10 Screw the hand knob onto the bolt, securing the lid onto the housing.**



CAUTION: Wear eye protection.

If you use compressed air to clean the equipment, you must wear eye protection and observe all OSHA and other safety regulations pertaining to the use of compressed air. Blow from inside to outside.

Cleaning the Regeneration Filters

Clogged filters reduce air flow and dryer efficiency. Cleaning frequency depends on how much material you process and how dusty or full of fines it is.



CAUTION: Hot Surfaces

Always protect yourself from hot surfaces inside and outside the dryer and drying hopper.

- 1** Shut down the dryer, disconnect and follow lockout procedures.



- 2** Allow the dryer to cool. Locate the Regeneration filter on the front of the dryer. It has a label identifying it.

- 3** Remove the wing nut holding the filter and cap in place.



- 4** Sometimes the cap will stick to the gasket of the filter, simply pull them apart to separate.



- 5** Clean or replace the filter.

- 6** Place the filter back in place, with the cap and wing nut holding it.



Cleaning the Conveying Filter



CAUTION: Wear eye protection.

If you use compressed air to clean the equipment, you must wear eye protection and observe all OSHA and other safety regulations pertaining to the use of compressed air. Blow from inside to outside.

The conveying filter captures dust and fines from the air used to convey material. The filter should be cleaned regularly to maintain conveying airflow and optimum performance of the conveying blower.

1 Shut down the dryer, disconnect and follow lock-out procedures.

2 Allow the dryer to cool – surfaces may be hot.

3 Locate the Conveying system filter on the front of the dryer. It is the filter in the lower part of the chassis, below the Regeneration filter.

4 Remove the filter housing cover by loosening and remove the hand knob.



5 Remove the filter cartridge.



6 Inspect and clean or replace as necessary.

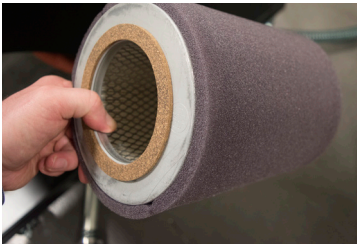

7 Wipe the inside of the filter housing clean, then replace the filter cartridge into the housing.



8 Replace the filter housing cover, and secure with the hand knob.



Cleaning the Vacuum Receiver

The vacuum receiver should be cleaned anytime you change materials. Replace the screen mesh filter if it is torn, damaged, distorted or so clogged with material that it cannot be cleaned.

- 1** Turn off switch to stop conveying. Disconnect the air and material hoses from the vacuum receiver.
- 2** Open the vacuum receiver lid. Turn the latch counterclockwise and flip the lid open.
- 3** Remove and clean the mesh filter. Lift the mesh filter out of the vacuum receiver. Clean or replace as necessary.
- 4** Loosen the 3 thumbscrews, slide the clips aside, and lift the vacuum receiver body from the viewing chamber. Clean inside the vacuum receiver body with a clean rag.
- 5** Remove and clean the viewing chamber. Lift the viewing chamber to release it from the mounting bracket. Clean inside with a clean rag.
- 6** Reassemble the vacuum receiver. Make sure the viewing chamber and loader body seat snugly inside the O-ring couplings.

 **NOTE:** The receiver on the hopper must also be cleaned with self-loading option, [see Screen Filter Cleaning](#).



CAUTION: Wear eye protection.

If you use compressed air to clean the equipment, you must wear eye protection and observe all OSHA and other safety regulations pertaining to the use of compressed air.

Screen Filter Cleaning (optional)

 **DANGER: Electrical and air hazard**

 Always disconnect the main power source and compressed air source before removing the filter. This prevents the loader from starting during servicing, which could cause injury from flying debris or moving parts.

 **CAUTION: Wear eye protection**

We recommend that you use vacuum air for cleaning filters and other parts of this equipment. If you use compressed air to clean the equipment, you must wear eye protection and observe all OSHA and other safety regulations pertaining to the use of compressed air.



The screen filter of your TLR is typically cleaned when materials are changed and in the event of conveying problems.

- 1 Turn off power.** Turn off the TLR loader or disconnect the control connection cable from the UTB.
- 2 Remove the filter.** Open the lid of the TLR by releasing the swing clamp that secures the lid. Once the lid is opened, the screen filter is easily visible, installed in the top of the tube loader body and may be lifted out for inspection or cleaning.
- 3 Inspect the filter carefully.** Check for holes that could allow the passage of pellets or regrind. Replace the filter if it is damaged, excessively worn or too clogged with fines and dust to be cleaned. Be sure to discard and replace any filter that has become hopelessly clogged with material dust. Do not attempt to repair a damaged filter.
- 4 Clean the filter.** A simple wipe down with a clean cloth or vacuuming will typically remove most material dust and fines. Slight tapping of the filter on a hard surface will loosen more embedded fines, but hard banging could distort or ruin the filter media and should be avoided.
- 5 Replace the filter.** Replace the filter onto the loader. Firmly press down on the filter to make sure there is a good seal around the entire perimeter of the filter module.

 **NOTE:** The filter in your Conair TLR Tube Loader performs double-duty as an effective seal between the hopper body and the lid of the loader, so be sure to examine the integrity of the rubber seal at the top to ensure that the lid will seal effectively when resealed. Replace the entire filter if the rubber seal is damaged or excessively worn.

Cleaning the Compressed Air Filter (optional)

You can add a moisture trap to the compressed air supply of your loader. A moisture trap can prevent troublesome moisture, contained in the air, from entering the loader.

The filter bowl of this moisture trap must be emptied regularly to drain the water from the air system. Follow the instructions listed on the filter bowl itself, which usually requires opening a port at the base of the bowl and letting the water in the bowl blow out in a stream of compressed air. Creating a path for this blowout of moisture is usually a good idea, to prevent a stream of moisture-soaked air from contaminating machines or people.

It is also a good idea to inspect the bowl periodically with the compressed air supply turned off, to clean or replace the filter element if need be or to remove contaminant accumulation, if it is present.



Cleaning the Optional Water-to-Air Aftercooler Coils

You need to clean the aftercooler coils to keep them working efficiently. Cleaning frequency depends on the type and amount of material you process.



CAUTION: Hot Surfaces

Always protect yourself from hot surfaces inside and outside the dryer and drying hopper.

- 1 Stop the dryer and lockout the main power.**
- 2 Turn off the water flow to the water supply line.** Disconnect supply and return lines.
 **NOTE:** If an optional flow control was added with the aftercooler, remove the compression fitting from the aftercooler inlet. Loosen the fitting on the flow control, then swing the copper water supply tube out and away from the aftercooler inlet.
- 3 Remove the two (2) nuts securing the aftercooler in the housing.**
 **TIP:** If the aftercooler (without a flow control) was installed using the recommended 24 inches {61 cm} of flexible hoses, there is no need to disconnect the hoses from the aftercooler inlet and outlet.
- 4 Remove the aftercooler assembly from the aftercooler housing.**
- 5 Clean the assembly using a mild soap and water.** Let the assembly dry thoroughly before installation.
- 6 Inspect the condition of the gasket.** If it is damaged, replace the gasket.
- 7 Reassemble by repeating the steps in reverse order.**
- 8 Connect the water supply line to the inlet.** If a manual shut off valve is used, it should be mounted on the inlet line as well.
- 9 Connect the outlet of the aftercooler to the inlet of the flow control valve** using the pre-shaped copper tubing and compression fittings provided.



Cleaning the Precooler Coils

If you have the optional precooler, you need to clean the cooling coils to keep them working efficiently. See Appendix B for details.



CAUTION: Hot Surfaces

Always protect yourself from hot surfaces inside and outside the dryer and drying hopper.

Inspecting Hoses and Gaskets

Loose or damaged hoses and gaskets can allow moisture to seep into the closed-loop drying system.



CAUTION: Hot Surfaces

Always protect yourself from hot surfaces inside and outside the dryer and drying hopper.

- 1 Follow the hose routing of all the hoses within the dryer and inspect all hoses, clamps, fittings, and gaskets.**
- 2 Tighten any loose hose clamps or fittings.**
- 3 Replace worn or damaged hoses and gaskets.**

Cleaning and Servicing the Desiccant Rotor

Visually inspect the wheel for blockage from dirt. Use drop light or strong flashlight on one side of wheel. Light should be visible on other side of wheel. If more than 15% blockage exists, wheel should be cleaned.



Example of a Clean Desiccant Rotor



Example of a Desiccant Rotor with More Than 15% Blockage

 **NOTE:** Photos are samples for representation only. The appearance of your wheel may be different.

- 1 Use a wet vac with soft brush nozzle to vacuum both wheel faces.**
- 2 Re-inspect**, if blockage still exists, use maximum 30 psig dry compressed air, no closer than 12" from wheel face to blow dirt from wheel. Combine vacuum for added assistance.
- 3 If blockage still exist no further field cleaning is possible.** The wheel should be replaced.
- 4 The desiccant wheel should be dried out soon after the washing process** to minimize the stresses placed on the wheel structure by the substantial water weight increase.
- 5 The wheel may be dried by returning it to the dehumidifier.**
- 6 Run the unit in this manner until the reactivation outlet temperature reaches 120°F minimum.** Then run an additional 10 minutes.

For information on replacing the Desiccant Rotor, [see Chapter 6, Replacing the Desiccant Wheel Assembly](#).

Troubleshooting

Before Beginning	6-2
A Few Words of Caution.....	6-3
Identifying the Cause of a Problem	6-3
Shutdown Alarms	6-4
Passive Alarms	6-8
Poor Material Drying Troubleshooting	6-15
Replacing Fuses.....	6-20
Checking or Replacing Temperature Sensors.....	6-20
Replacing the Heaters.....	6-22
Replacing the Desiccant Wheel Assembly	6-24
Inspecting/Cleaning the Air-to-Air Aftercooler.....	6-25

A Few Words of Caution

The dX Series Carousel Plus dryer is equipped with numerous safety devices. Do not remove or disable them. Improper corrective action can lead to hazardous conditions and should never be attempted to sustain production.



WARNING: Improper installation, operation or servicing may result in equipment damage or personal injury.

This equipment should only be installed, adjusted, and serviced by qualified technical personnel who are familiar with the construction, operation, and potential hazards of this type of machine.

All wiring, disconnects, and fuses should be installed and adjusted by qualified electrical technicians in accordance with electrical codes in your region. Always maintain a safe ground. Do not operate the equipment at power levels other than what is specified on the machine serial tag and data plate.



WARNING: Voltage hazard



Always stop the Carousel Plus dryer, disconnect and lock out the main power source before troubleshooting or performing repairs.





CAUTION: Hot Surfaces

Always protect yourself from hot surfaces inside and outside the dryer and hopper.

Identifying the Cause of a Problem

 **NOTE:** Pushing the Alarm button when there is no active alarm will take the user directly to the Alarm History list.

 **NOTE:** The dryer cannot be started if a shut down alarm is present on power-up.

 **NOTE:** When the dryer detects abnormally high temperature in the process heater, the dryer immediately shuts down and an error message appears in the display window.



Most dryer alarms are indicated by an Alarm Banner at the top of the screen. Shutdown alarms will sound a horn and turn on the alarm beacon.

A problem can trigger two types of alarms:

- **Shutdown:** The dryer has automatically shut down because it detected a serious problem that could damage your material or dryer.
- **Passive:** The dryer continues to operate, but warns of a problem that could prevent correct drying of your material. If ignored, this problem could lead to a condition that will shut down the dryer.

When the alarm banner is displayed:

- 1 Press the Alarm banner to display the alarm message.
- 2 Find the error message in the diagnostics table of this Troubleshooting section. Use information provided to diagnose and resolve the cause of the alarms.



 **NOTE:** Pressing the  button a second time will clear the alarm once the cause has been corrected. If the alarm reappears, the cause has not been resolved.

Before Beginning

You can avoid most problems by following the recommended installation, operation and maintenance procedures outlined in this User Guide. If you have a problem, this section will help you determine the cause and tell you how to fix it.

Before you begin troubleshooting:

Diagnose causes from the control panel.

- 1 Press  once to silence the optional audible alarm and display the alarm message.
- 2 Address the alarm message and fix the problem. (Refer to the alarm descriptions later in this section.)
- 3 Press  again to clear the alarm. If the alarm reappears the problem was not fixed.

 **NOTE:** Not all alarms listed in this guide may apply to your dryer.

 **NOTE:** Use of I/O test screens may assist with the determining of possible cause of an alarm.

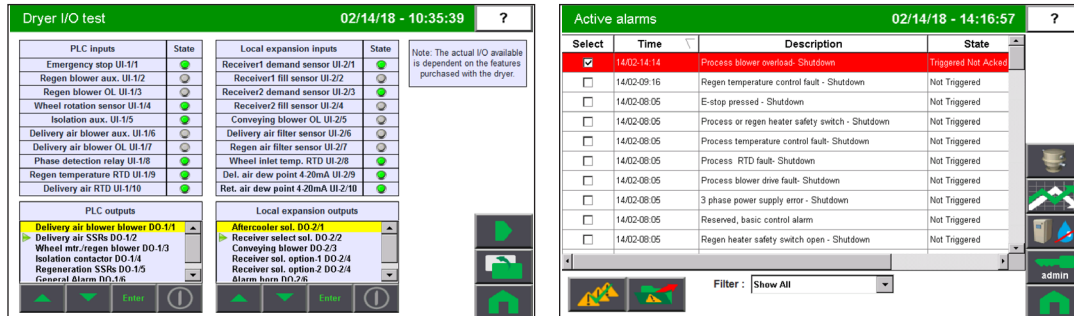

4

- Find any wiring, parts, and assembly diagrams that were shipped with your equipment.** These are the best reference for correcting a problem. The diagrams will note any custom features or options not covered in this User Guide.
- Verify that you have all instructional materials related to the dX.** Additional details about troubleshooting and repairing specific components are found in these materials.
- Check that you have manual for other equipment connected in the system.** Troubleshooting may require investigating other equipment attached to, or connected with the dX.

Additional manuals and prints for your Conair equipment may be ordered through the Customer Service or Parts Department for a nominal fee. Most manuals can be downloaded free of charge from the product section of the Conair website. www.conairgroup.com

Contact Conair
 Parts and Service
 Phone: 800-458-1960
 From outside of the
 United States,
 Call: 814 437 6861

Shutdown Alarms

If the Alarm Banner is red the alarm is a shutdown alarm. The dryer will shutdown automatically to prevent damage to the equipment or personnel.

Contact Conair
Parts and Service
Phone:
800-458-1960
From outside of the
United States,
Call: 814 437 6861

Symptom	Possible Cause	Solution
E-stop pressed	E-stop pressed.	Resolve any issues, reset E-stop. Ensure dryer was shutdown properly instead of using E-stop. This is intended for emergency use only.
Process or regeneration heater safety switch open The snap switch in the process/regeneration heater tube opens due to excessive temperature.	Loose wire to coil of isolation contactor. Temperature switch is open. Defective coil on isolation contactor. Process or regeneration blower not running or out of phase. Process or regeneration blower not running. Loose or missing hose, blockage.	Verify control wire connection to isolation contactor, Check continuity of heater snap switch. Verify control wire connection to isolation contactor. Verify blower rotation and operating. Verify process and regeneration blowers are operating. Check for loose, blocked, or missing hose.
Process temperature control fault The process temperature is not moving towards the setpoint at a rate greater than specified.  NOTE: 15 degree band from setpoint for 10 seconds.	Process RTD is loose or has fallen out. Process heater has failed, air line is restricted. Process blower is not running or is running in wrong direction. Solid state relay has failed on.	Check process RTD and tighten if needed. Check heater fuses & resistance across each leg of process heater. Fix any crimps in hoses, and correct cause for non-running blower or reverse rotation. Check heater fuses & resistance across each leg of process heater.

Shutdown Alarms (continued)

If the Alarm Banner is red the alarm is a shutdown alarm. The dryer will shutdown automatically to prevent damage to the equipment or personnel.

Symptom	Possible Cause	Solution
Process RTD fault The process RTD is loose or plug-in I/O module is loose/faulty.	The process RTD connection to the plug-in I/O module is loose.	Verify connection to the I/O module.
	The process RTD has failed,	Check RTD plug connection, and replace RTD if faulty. Measure resistance.
	The I/O module has failed.	Verify connection to the I/O module, replace plug-in I/O module if faulty.
Process blower overload If the process blower exceeds its full load amp rating or the overload has tripped due to a mechanical or electrical problem.	The process blower current draw has exceeded the FLA rating of the motor.	Manually reset the overload.
	The process blower has mechanically failed or is unable to rotate freely.	Check process blower for mechanical failure and free rotation.
	The process blower has failed electrically.	Check process blower for electrical short or open circuits.
3 phase power supply error One of the three power wires is connected wrong, or one or more phases of power is missing.	One of the three power wires are out of phase.	Switch the position of two of the incoming lead power wires at the dryer.
	A fuse has blown.	Check and replace the fuse.
	Phase monitor relay has failed.	Replace phase monitor relay.
High return air temperature If the return air temperature at the inlet to the blower is greater than 180°F.	The hopper does not contain enough material.	Make sure material supply system is working properly.
	The user is drying at high temperatures or are running low throughputs.	Lower temperature or raise throughputs.
	Water-cooled aftercooler does not have water/enough water.	Ensure aftercooler has adequate flow.
	Aftercooler coils are dirty.	Clean aftercooler coils.
	Ambient air temperature too high.	Cool the area. Add optional water-cooled aftercooler.

Shutdown Alarms (continued)

If the Alarm Banner is red the alarm is a shutdown alarm. The dryer will shutdown automatically to prevent damage to the equipment or personnel.

Symptom	Possible Cause	Solution
<p>Regeneration heater safety switch open</p> <p>The snap switch in the regeneration heater tube opens due to excessive temperature.</p> <p> NOTE: Only for central dryer configuration</p>	Loose wire to coil of isolation contactor.	Verify control wire connection to isolation contactor.
	Temperature switch is open.	Check continuity of heater snap switch.
	Defective coil on isolation contactor.	Verify control wire connection to isolation contactor.
	Process blower not running or out of phase.	Verify blower rotation.
	Regeneration blower not running.	Verify regeneration blower is operating.
	Loose or missing hose, blockage.	Check for loose or missing hose.
<p>Regeneration temperature control fault</p> <p>The regeneration temperature is not moving towards the setpoint at a rate greater than specified.</p>	Regeneration RTD is loose or has fallen out.	Check regeneration RTD and tighten if needed.
	Regeneration heater has failed.	Check heater fuses & resistance across each leg of regeneration heater.
	Air line is restricted.	Fix any crimps in hoses.
	Regeneration blower is not running or is running in wrong direction.	Fix any crimps in hoses, and correct cause for non-running blower or reverse rotation.
	Solid state relay has failed on.	Check heater fuses & resistance across each leg of regeneration heater.

Shutdown Alarms (continued)

If the Alarm Banner is red the alarm is a shutdown alarm. The dryer will shutdown automatically to prevent damage to the equipment or personnel.

Symptom	Possible Cause	Solution
Regeneration RTD fault The regeneration RTD is loose or plug-in I/O module is loose/faulty.	The regeneration RTD connection to the plug-in I/O module is loose.	Verify connection to the I/O module and check RTD plug connection.
	The regeneration RTD has failed.	Check RTD plug connection and replace RTD if faulty. (Measure resistance).
	The I/O module has failed.	Replace plug-in I/O module.
Desiccant wheel not rotating The desiccant wheel is not turning.	The desiccant motor or motor coupling has failed.	Verify desiccant motor or motor coupling has not failed.
	The gap setting of the proximity switch is incorrect.	Verify gap setting of proximity switch.
	Belt is loose.	Verify belt tension.
Startup failed at process blower Process blower did not start	Process blower starter did not turn on.	Check connections to coil of starter, check connection to auxiliary contact of starter.
Startup failed at regen blower Regeneration blower did not start.	Regeneration blower starter did not turn on.	Check connections to relay.
Startup failed at isolation contactor Isolation contactor failed to come on.	Isolation contactor failed to come on.	Check control connections to isolation contactor, and verify heater high temperature switches are closed.
Startup failed at SSRs Temperature control loop did not come on.	Corrupt PLC program.	Restore program from Eprom.

Passive Alarms

If the Acknowledge Alarm light is blinking, the alarm is a passive alarm. The dryer continues to operate, but this problem could prevent correct drying of your material.

Symptom	Possible Cause	Solution
Dewpoint high The dewpoint has not fallen below the setpoint.	Defective DP sensor.	Replace DP sensor.
	Hose or wiring connector to the sensor block are loose or fallen off.	Check hose and wiring connections to sensor block.
	Poor regeneration air flow.	Remove air flow restrictions or replace dirty filters.
	The desiccant wheel may be contaminated.	Check desiccant for contamination and replace if need; install volatile trap if necessary.
	Leaks in the process air stream.	Check for worn or loose hoses.
	Desiccant wheel not rotating.	Check drive motor and motor coupling for failure.
Return air temperature too high.	Verify water flow to after cooler.	
Clean or replace process filter The process filter differential pressure switch is tripped.	The process filter is clogged.	Remove and clean or replace te process air filter.
Return air RTD fault The return air RTD is loose or plug-in I/O module is loose/faulty.	The return air RTD connection to the plug-in I/O module is loose.	Verify connection to the I/O module, and check RTD plug connection.
	The return air RTD has failed.	Replace RTD.
	The I/O module has failed.	Replace plug-in I/O module.
Hopper outlet RTD fault The temperature setback RTD is loose or plug-in I/O module is loose/faulty.	The temp setback air RTD connection to the plug-in I/O module is loose.	Verify connection to the I/O module, and check RTD plug connection.
	The temp setback air RTD has failed.	Replace RTD.
	The I/O module has failed.	Replace plug-in I/O module.

Passive Alarms (continued)

If the Acknowledge Alarm light is blinking, the alarm is a passive alarm. The dryer continues to operate, but this problem could prevent correct drying of your material.

Symptom	Possible Cause	Solution
Conveying/pump overload If the conveying blower exceeds its full load amp rating or the overload has tripped due to a mechanical or electrical problem.	The conveying blower current draw has exceeded the FLA rating of the motor.	Manually reset the overload.
	The conveying blower has mechanically failed or is unable to rotate freely.	Check conveying blower for mechanical failure and free rotation.
	the conveying blower has failed electrically.	Check conveying blower for electrical short or open circuits.
Drying monitor low temperature Active Drying Monitor RTD is below setpoint.	Low process airflow.	Clean or replace process air filter.
	Low process temperature.	Verify operation of process heater.
	Throughput exceeded.	Verify actual throughput vs. dryer sizing.
	No material in hopper or conveying issues.	Verify conveying system working properly.
Drying monitor high temperature Active Drying Monitor RTD is above setpoint.	Material throughput is too low.	Ensure the material usage is within the rated capacity of the dryer/hopper.
	Material level in hopper is above the selected high temperature alarm RTD.	Check material supply system for problems.
	Process air is not at the proper temperature.	Reduce the process air temperature.
	Too much air flow to the hopper.	Reduce air flow.

Passive Alarms

If the Acknowledge Alarm light is blinking, the alarm is a passive alarm. The dryer continues to operate, but this problem could prevent correct drying of your material.

Symptom	Possible Cause	Solution
Drying monitor T1 RTD fault RTD has failed or DM cable connection is loose.	The RTD has failed.	Replace DM probe.
	DM cable connection is loose.	Check DM cable connection.
	Connection to I/O module is loose.	Check DM cable connection.
Drying monitor T2 RTD fault RTD has failed or DM cable connection is loose.	The RTD has failed.	Replace DM probe.
	DM cable connection is loose.	Check DM cable connection.
	Connection to I/O module is loose.	Check DM cable connection.
Drying monitor T3 RTD fault RTD has failed or DM cable connection is loose.	The RTD has failed.	Replace DM probe.
	DM cable connection is loose.	Check DM cable connection.
	Connection to I/O module is loose.	Check DM cable connection.
Drying monitor T4 RTD fault RTD has failed or DM cable connection is loose.	The RTD has failed.	Replace DM probe.
	DM cable connection is loose.	Check DM cable connection.
	Connection to I/O module is loose.	Check DM cable connection.
Drying monitor T5 RTD fault RTD has failed or DM cable connection is loose.	The RTD has failed.	Replace DM probe.
	DM cable connection is loose.	Check DM cable connection.
	Connection to I/O module is loose.	Check DM cable connection.

Passive Alarms

If the Acknowledge Alarm light is blinking, the alarm is a passive alarm. The dryer continues to operate, but this problem could prevent correct drying of your material.

Symptom	Possible Cause	Solution
Drying monitor T6 RTD fault RTD has failed or DM cable connection is loose.	The RTD has failed.	Replace DM probe.
	DM cable connection is loose.	Check DM cable connection.
	Connection to I/O module is loose.	Check DM cable connection.

Passive Alarms Hopper Loader

If the Acknowledge Alarm light is blinking, the alarm is a passive alarm. The dryer continues to operate, but this problem could prevent correct drying of your material.

Symptom	Possible Cause	Solution
#1 Resin loading fault “loader name” The demand sensor located at the hopper receiver has not been satisfied.	The sensor is not adjusted properly.	Adjust sensor.
	No material is being conveyed.	Check material supply.
	Conveying load time is too short.	Increase load time
	Conveying blower is not operating.	Check conveying blower fuses and overload settings.
	The conveying filter is clogged.	Clean or replace conveying filter.
	Hoses have come off or are loose.	Check for loose hoses.
	The air valves are not opening.	Make sure compressed air is connected and that solenoid valves are operating properly.

Passive Alarms

Hopper Loader (continued)

If the Acknowledge Alarm light is blinking, the alarm is a passive alarm. The dryer continues to operate, but this problem could prevent correct drying of your material.

Symptom	Possible Cause	Solution
#1 “loader name” fill sensor fault The demand sensor located at the receiver has failed.	The sensor is not adjusted properly.	Adjust sensor.
	No material is being conveyed.	Check material supply.
	Conveying load time is too short.	Increase load time.
	Conveying blower is not operating.	Check conveying blower fuses and overload settings.
	The conveying filter is clogged.	Clean or replace conveying filter.
	Hoses have come off or are loose.	Check for loose hoses.
	The air valves are not opening.	Make sure compressed air is connected and that solenoid valves are operating properly.
#1 “loader name” fill time exceeded The fill sensor is not on within 110% of the load time.	The fill and demand sensors are both on.	Either the fill or demand sensor are defective and needs replacing.

Passive Alarms

Machine Loader

If the Acknowledge Alarm light is blinking, the alarm is a passive alarm. The dryer continues to operate, but this problem could prevent correct drying of your material.

Symptom	Possible Cause	Solution
#2 Resin loading fault “loader name” The demand sensor located at the machine receiver has not been satisfied.	The sensor is not adjusted properly.	Adjust sensor.
	No material is being conveyed	Check material supply.
	Conveying load time is too short.	Increase load time.
	Conveying blower is not operating.	Check conveying blower fuses and overload settings.
	The conveying filter is clogged.	Clean or replace conveying filter.
	Hoses have come off or are loose.	Check for loose hoses.
	The air valves are not opening.	Make sure compressed air is connected and that solenoid valves are operating properly.
#2 “loader name” fill sensor fault The demand sensor located at the receiver has failed.	The sensor is not adjusted properly.	Adjust sensor.

Passive Alarms

Machine Loader (continued)

If the Acknowledge Alarm light is blinking, the alarm is a passive alarm. The dryer continues to operate, but this problem could prevent correct drying of your material.

Symptom	Possible Cause	Solution
#2 “loader name” fill time exceeded	No material is being conveyed.	Check material supply.
	Conveying load time is too short.	Increase load time.
	Conveying blower is not operating.	Check conveying blower fuses and overload settings.
	The conveying filter is clogged.	Clean or replace conveying filter.
	Hoses have come off or are loose.	Check for loose hoses.
	The air valves are not opening.	Make sure compressed air is connected and that solenoid valves are operating properly.

Poor Material Drying Troubleshooting

Occasionally, processing problems that are suspected of being caused by poor drying are eventually determined to be the result of other issues in the process setup. The information can assist you in determining if your drying system is performing properly. However, the only way to know definitely if your material is properly dried is to perform moisture analysis of small samples as it leaves the bottom of the hopper or just as it enters the process. Conair does not sell moisture-analyzing equipment, but there are many brands of this equipment available on the market.

You should also be aware that some processing problems may actually be the result of over drying material. Most materials will degrade to some extent if they are exposed to their specified drying temperature for a time significantly longer than the residence time specified by the supplier. If you want to maintain its dryness, it is recommended that you reduce the process air temperature. If your Conair dryer is equipped with the Setback feature, you should familiarize yourself with it, and make use of it. If not, you may want to contact Conair to determine if it can be added to your dryer.

A majority of customer questions to Conair are related to dewpoint. It is important to realize that dewpoint is one of four requirements that need to be satisfied.

There are four requirements, listed in order of importance, necessary to properly dry hygroscopic plastic resins:

- 1** Drying temperature of the air entering the hopper must be at the proper drying temperature for your material, as specified by your material supplier.
- 2** Residence time is the time, determined by your material supplier, that the material in use must be heated to achieve proper drying temperature.
- 3** Airflow during the process drying circuit must be adequate to carry and distribute the heat throughout the entire bed of material inside the hopper.
- 4** Dewpoint of the process air must be low so it can efficiently collect the moisture as it is released from the heated material and carry it to the dryer to be removed in the desiccant.

Once it is determined which of the four requirements that is not being satisfied, refer to the following list and possible causes and solutions.

Contact Conair
Parts and Service
Phone: 800-458-1960
From outside of the
United States,
Call: 814 437 6861

Poor Material Drying Troubleshooting (continued) Temperature

The temperature of the air entering the hopper must be at the proper drying temperature for your material, as specified by your supplier.

Symptom	Possible Cause	Solution
The temperature of the air entering the hopper is not at proper drying temperature.	Incorrect setpoint.	Refer to the drying specifications for your material and adjust the setpoint to the recommended setpoint. Check Setback Temp to make sure is not active unless you have specifically activated it. If necessary, see the Operation section of this manual for assistance in using the Setback function.
	Not able to achieve setpoint.	Replace any defective process heater, contactors, fuses, etc. Ensure the selected drying temperature is within the design specifications of your dryer.
	Inaccurate process temperature readout.	Ensure the Process RTD is properly positioned in the air stream. Determine if there is a problem in the temperature control circuit and repair or replace any defective components such as RTD, temperature control, circuit boards, etc.

Poor Material Drying Troubleshooting (continued)

Residence Time



The time your material supplier has determined that the material in use must be heated to its drying temperature to achieve proper drying.

Symptom	Possible Cause	Solution
Material residence time is too long or short.	Material level in hopper is too low.	<p>Make sure there is an adequate supply of material to feed the loader on top of the drying hopper.</p> <p>Correct any problems with the conveying system that may be preventing your loader from filling the hopper.</p> <p>If your hopper has a level sensor for maintaining a material level less than completely full, be sure this sensor is adjusted properly.</p>
	Material throughput is too high.	Take any necessary steps, such as slowing down the process, to ensure the material usage is within design specifications of the dryer and hopper.

Poor Material Drying Troubleshooting (continued)

Air Flow

The airflow in the process drying circuit must be adequate to carry and distribute the heat throughout the entire bed of material inside the hopper. If the airflow is too low, the material in the center of the hopper may get heated fully to the drying temperature, but the material against the sidewalls will not. In most cases, the material 2/3 to 3/4 of the way toward the top of the hopper should be heated to the proper drying temperature.

Symptom	Possible Cause	Solution
<p>Too much or too little airflow.</p> <p> NOTE: If there is too much airflow, the material may fluidize inside the hopper, resulting in inconsistent material flow through the hopper, which can negatively impact residence time.</p>	Dirty process air filter.	Clean or replace the process filter.
	Collapsed hoses or holes/leaks in the hoses and hose connection.	Replace any damaged hoses. Tighten all hose clamps to eliminate leaks.
	Airflow restrictions.	Remove any obstructions in the process air circuit.
	Process blower running backwards or performing poorly.	<p>Verify the process blower is running in the correct direction. If backwards, reverse direction by switching any 2 legs of high voltage to the motor.</p> <p> WARNING:</p> <p>Any electrical checks should be performed by a qualified electrician.</p> <p>Repair or replace motor.</p>
Material level in the hopper too low.	<p>Other than running out of material to complete a job, the material level inside the hopper must be a minimum of 50% full. If the hopper is not at least half full, the material in the cone section will not get adequate airflow to dry properly.</p>	

Poor Material Drying Troubleshooting (continued)

Dewpoint

Contact Conair
 Parts and Service
 Phone: 800-458-1960
 From outside of the
 United States,
 Call: 814 437 6861

The process air must be at a low dewpoint so it can efficiently collect the moisture as it is released from the heated material and carry it to the dryer to be removed in the desiccant. In most cases, the dryer will dry your material satisfactory if the dewpoint of the air is -20 to -40° F {-29 to -40° C}. If your dryer does not have a dewpoint readout, you can check the dewpoint with a portable dewpoint instrument. Conair sells a variety of portable dewpoint meters. Contact Conair Parts.

Symptom	Possible Cause	Solution
Dryer dewpoint is not reaching proper setpoint.	Low regeneration temperature.	Replace or check defective heaters, fuses etc.
	Poor regeneration airflow.	Clean or replace the regeneration filter.
		Ensure the regeneration blower is operating properly and rotating in the correct direction.
		Remove obstructions in the air stream, such as crimped hoses, etc.
High dewpoint, ambient air leaking into the closed loop drying circuit.	Replace damaged hoses and seal any leaks in the process air circuit.	
	If using a vacuum loader on the hopper, ensure that the loader shroud is installed in the hopper and that the hopper is completely filled with material.	
	If partially filling your hopper, ensure that the hopper loader is sealed against ambient air.	
Return air temperature to the dryer is too high.	Install a gasket between the loader and the top of the hopper.	
	Clean the aftercooler coils. <i>See Maintenance section entitled, Cleaning the aftercooler coils.</i>	
Poor desiccant performance.	<i>See Troubleshooting section entitled, Replacing the desiccant wheel assembly.</i>	

Replacing Fuses



NOTE: To locate the appropriate fuse and replacement part, refer to the wiring diagrams that came with your dryer.

1 Disconnect and lockout the main power supply.



WARNING: Voltage hazard



Always disconnect and lock out the incoming main power source before opening the electrical enclosure or performing non-standard operating procedures, such as routine maintenance. Only qualified personnel should perform troubleshooting procedures that require access to the electrical enclosure while power is on.

2 Open the electrical enclosure door.

3 Check the disconnect/fuse. If necessary, replace it with a disconnect/fuse of the same type and rating.

IMPORTANT: Always refer to the wiring diagrams that came with your dryer to locate specific electrical components. Illustrations in the User Guide are intended to be representative only.

Checking or Replacing Temperature Sensors

The dX dryer uses RTD sensors to monitor the temperatures of the drying air, the return air, the regeneration outlet, and the regeneration protection and setback at the outlet heater of the hopper.

IMPORTANT: Always refer to the wiring diagrams that came with your dryer to locate specific electrical components. Illustrations in the User Guide are intended to be representative only.



Location of the Process RTD at the Hopper inlet.

Checking or Replacing Temperature Sensors (continued)

To check or replace RTD sensors:



WARNING: Voltage hazard



Always disconnect and lock out the incoming main power source before opening the electrical enclosure or performing non-standard operating procedures, such as routine maintenance. Only qualified personnel should perform troubleshooting procedures that require access to the electrical enclosure while power is on.

- 1 Disconnect and lockout the main power supply.**
- 2 Remove rear plastic cover, as necessary.**
- 3 Locate the RTD sensors.**
- 4 Check the sensor positions and conditions.** Temperature readings will be incorrect, if the sensors are touching the wall of an air hose or pipe or if the sensor or wiring is damaged. The tip of the sensor should be centered within the air hose or pipe. Sensor wires should be attached to the appropriate connection points on the dryer's electrical enclosure or microprocessor board.
- 5 To check with ohm meter, measure the resistance across the RTDs.** The resistance should be approx. 110 ohm at room temperature.
- 6 Replace the sensor, if necessary.**



Replacing the Heaters

Regeneration Heater Tube

 **NOTE:** It is not necessary to remove the plastic cover to perform this procedure.



1 Stop the dryer, disconnect the power, and follow proper lockout procedures.

 **WARNING: Voltage hazard**

 Always disconnect and lock out the incoming main power source before opening the electrical enclosure or performing non-standard operating procedures, such as routine maintenance. Only qualified personnel should perform troubleshooting procedures that require access to the electrical enclosure while power is on.



2 Remove the hardware securing the metal top, rear, and sides of the dryer.

 **CAUTION: Hot Surfaces**

Always protect yourself from hot surfaces inside and outside the dryer and drying hopper.

3 Remove the top, and rear/side piece of the dryer panels.

4 Working from the left side of the machine, locate the regeneration heater tube.

5 Disconnect the heater wiring harness at the quick disconnects..

6 Loosen the hose clamps at the top and bottom of the heater tube and remove the heater tube from the dryer.

Insulation

Clamp

Wires



7 Slide the insulation off or make a straight cut in the insulation, and remove it from the defective heater tube.

8 Check the ID mark on the side of the heater tube for kW rating and voltage. The ID mark is on the outside of the tube near the end with the lead wires.

9 Place the insulation on the new heater tube. Make sure to duct tape the seam that was cut during removal, if necessary.

10 Install the new heater tube and secure it in place with hose clamps at the top and bottom. Be sure the end of the heater tube with the cables is oriented toward the bottom.

11 Connect the heater tube cables to the quick disconnect of the control box wiring harnesses.

12 Reinstall the rear/side dryer panel, followed by the top panel section, using all the original hardware.

13 Make sure the regeneration heater fuses are not blown before applying power to the new heater.

14 Connect the power and start the dryer.



Regen Heater Tube

D150-400 Delivery Air Heater Tube

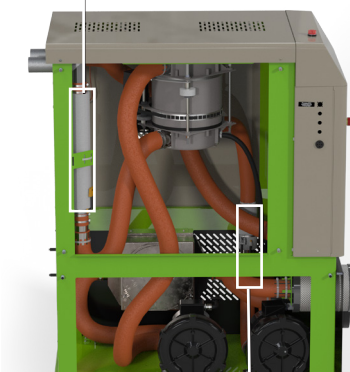

D150-400 Regen Heater Tube

Replacing the Heaters (continued)

Process Heater Tube

- 1 Stop the dryer, disconnect the power, and follow proper lockout procedures.

 **WARNING: Voltage hazard**

 Always disconnect and lock out the incoming main power source before opening the electrical enclosure or performing non-standard operating procedures, such as routine maintenance. Only qualified personnel should perform troubleshooting procedures that require access to the electrical enclosure while power is on.



- 2 Remove the hardware securing the metal top, rear, and sides of the dryer.

 **CAUTION: Hot Surfaces**

Always protect yourself from hot surfaces inside and outside the dryer and drying hopper.

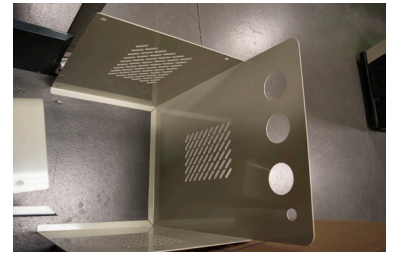

- 3 Remove the top, and rear/side piece of the dryer panels.

- 4 Working from the left side of the machine, locate the process heater tube.

- 5 Disconnect the heater wiring harnesses at the quick disconnects.

- 6 Loosen the hose clamps at the top and bottom of the heater tube.

- 7 Loosen the hose clamp securing the heater tube in place and remove the tube from the unit.

- 8 Slide the insulation off, or make a straight cut in the insulation and remove it from the defective heater tube.

- 9 Check the ID mark on the side of the heater tube for the kW rating and voltage and replace with a new heater tube with the same ratings. The ID mark is on the outside of the tube near the end with the lead wires.



- 10 Place the insulation on the new heater tube. Make sure to duct tape the seam that was cut during removal, if necessary.

- 11 Secure the new heater to the support tab with a hose clamp. Be sure the end of the heater tube with the cables is oriented toward the bottom.

- 12 Connect the hoses to the top and bottom of the heater tube, and secure with hose clamps. Be sure that the insulation of the top hose is in place and in good condition.

- 13 Connect the heater tube cables to the quick disconnects of the control box wiring harness.

- 14 Reinstall the rear/side dryer panel, followed by the top panel section, using all the original hardware.

- 15 Make sure the process heater fuses are not blown before applying power to the new heater.

- 16 Connect the power and start the dryer.

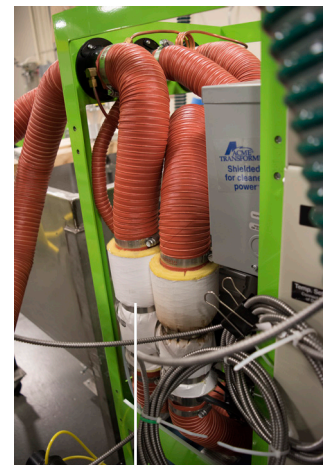

Process Heater



Process Heater D150-400

Replacing the Desiccant Wheel Assembly (dX 25 Shown)

If the desiccant becomes clogged or contaminated, you should replace the desiccant wheel to ensure optimum performance.

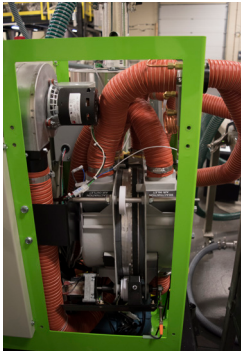
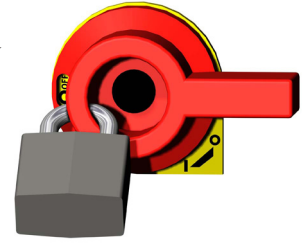

- 1 Stop the dryer, disconnect the power, and follow proper lockout procedures.**



WARNING: Voltage hazard



Always disconnect and lock out the incoming main power source before opening the electrical enclosure or performing non-standard operating procedures, such as routine maintenance. Only qualified personnel should perform troubleshooting procedures that require access to the electrical enclosure while power is on.

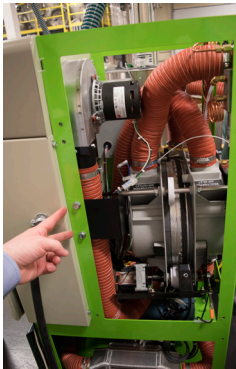

- 2 Remove the hardware securing the metal top, rear, and sides of the dryer.**



CAUTION: Hot Surfaces

Always protect yourself from hot surfaces inside and outside the dryer and drying hopper.

- 3 Remove the top, and rear/side piece of the dryer panels.**



NOTE: The two halves of the display must be separated to disconnect the wires from the display.



- 4 Working from the right side of the machine, you will see and have access to the desiccant wheel assembly.**

- 5 Disconnect all the hoses and RTDs from the wheel assembly. Be sure to note the positions of each (4th and 5th photo).**

- 6 Disconnect wires to the wheel motor.**

- 7 Remove four bolts securing the wheel assembly to the frame, then remove the desiccant wheel assembly from the dryer (2nd and 3rd photo).**

- 8 Position the new wheel assembly on the frame, with the motor to the right, as viewed from the front.**

- 9 Bolt the wheel assembly to the frame (2nd and 3rd photo).**

- 10 Reconnect the motor wires.**

- 11 Reconnect the hoses and RTDs to their original positions (4th and 5th photo).**

- 12 Reinstall the rear/side dryer panel, followed by the top panel section, using all the original hardware.**

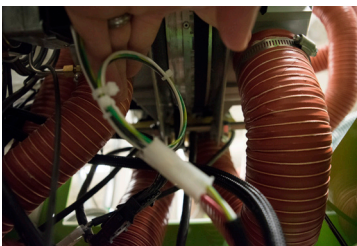
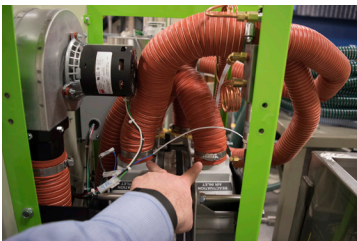

Inspecting/Cleaning the Air-to-Air Aftercooler

- 1 Shut down the dryer, disconnect and follow lockout procedures.

 **WARNING: Voltage hazard**

 Always disconnect and lock out the incoming main power source before opening the electrical enclosure or performing non-standard operating procedures, such as routine maintenance. Only qualified personnel should perform troubleshooting procedures that require access to the electrical enclosure while power is on.

 **CAUTION: Hot Surfaces**

Always protect yourself from hot surfaces inside and outside the dryer and drying hopper.



- 2 Allow the dryer to cool – surfaces may be hot.

- 3 Remove the hardware securing the metal top, rear, and sides of the dryer.



- 4 Remove the top, and rear/side piece of the dryer panels.

- 5 Working from the right side of the machine, you will see and have access to the air-to-air aftercooler. It is located below the desiccant wheel assembly, near the base of the cabinet.



- 6 Inspect the fins for any dust or other material that could be inhibiting air flow through the aftercooler. If the unit needs cleaned, continue this process.

- 7 Disconnect the wire from the fan at the back of the aftercooler.

- 8 Loosen the hose clamp, and remove the hose from the left side of the aftercooler.

- 9 Loosen the hose clamp, and remove the hose from the right side of the aftercooler.

- 10 Lifting on the left side of the aftercooler will allow it to slide up and out of the right side.

- 11 Using a vacuum or compressed air to clean the fins of the aftercooler.

- 12 Place the aftercooler back in position, and reconnect the hoses and wiring to the fan.

- 13 Reinstall the rear/side dryer panel, followed by the top panel section, using all the original hardware.

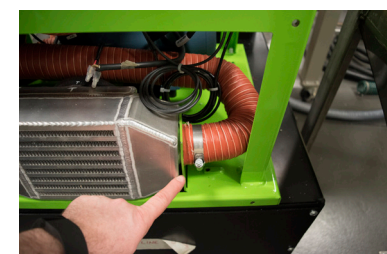

CAUTION: Wear eye protection.

If you use compressed air to clean the equipment, you must wear eye protection and observe all OSHA and other safety regulations pertaining to the use of compressed air.

We're Here to Help

Conair has made the largest investment in customer support in the plastics industry. Our service experts are available to help with any problem you might have installing and operating your equipment. Your Conair sales representative also can help analyze the nature of your problem, assuring that it did not result from misapplication or improper use.

How to Contact Customer Service

To contact Customer Service personnel, call:



Additional manuals and prints for your Conair equipment may be ordered through the Customer Service or Parts Department for a nominal fee.

Most manuals can be downloaded free of charge from the product section of the Conair website.

www.conairgroup.com



NOTE: Normal operating hours are 8:00 am - 5:00 pm EST. After hours emergency service is available at the same phone number.

From outside the United States, call: 814-437-6861

You can commission Conair service personnel to provide on-site service by contacting the Customer Service Department. Standard rates include an on-site hourly rate, with a one-day minimum plus expenses.

Before You Call...

If you do have a problem, please complete the following checklist before calling Conair:

- Make sure you have all model, control type from the serial tag, and parts list numbers for your particular equipment. Service personnel will need this information to assist you.
- Make sure power is supplied to the equipment.
- Make sure that all connectors and wires within and between control systems and related components have been installed correctly.
- Check the troubleshooting guide of this manual for a solution.
- Thoroughly examine the instruction manual(s) for associated equipment, especially controls. Each manual may have its own troubleshooting guide to help you.

Equipment Guarantee

Conair guarantees the machinery and equipment on this order, for a period as defined in the quotation from date of shipment, against defects in material and workmanship under the normal use and service for which it was recommended (except for parts that are typically replaced after normal usage, such as filters, liner plates, etc.). Conair's guarantee is limited to replacing, at our option, the part or parts determined by us to be defective after examination. The customer assumes the cost of transportation of the part or parts to and from the factory.

Performance Warranty

Conair warrants that this equipment will perform at or above the ratings stated in specific quotations covering the equipment or as detailed in engineering specifications, provided the equipment is applied, installed, operated, and maintained in the recommended manner as outlined in our quotation or specifications.

Should performance not meet warranted levels, Conair at its discretion will exercise one of the following options:

- Inspect the equipment and perform alterations or adjustments to satisfy performance claims. (Charges for such inspections and corrections will be waived unless failure to meet warranty is due to misapplication, improper installation, poor maintenance practices, or improper operation.)
- Replace the original equipment with other Conair equipment that will meet original performance claims at no extra cost to the customer.
- Refund the invoiced cost to the customer. Credit is subject to prior notice by the customer at which time a Return Goods Authorization Number (RGA) will be issued by Conair's Service Department. Returned equipment must be well crated and in proper operating condition, including all parts. Returns must be prepaid.

Purchaser must notify Conair in writing of any claim and provide a customer receipt and other evidence that a claim is being made.

Warranty Limitations

Except for the Equipment Guarantee and Performance Warranty stated above, Conair disclaims all other warranties with respect to the equipment, express or implied, arising by operation of law, course of dealing, usage of trade or otherwise, including but not limited to the implied warranties of merchantability and fitness for a particular purpose.

Cleaning the Precooler Coils (if Equipped)

If you have the optional precooler, you need to clean the coils to keep them working efficiently. Cleaning frequency depends on the type and amount of material you process.

- 1 Stop the dryer and lockout the main power.

 **WARNING: Voltage hazard**



Always disconnect and lock out the incoming main power source before opening the electrical enclosure or performing non-standard operating procedures, such as routine maintenance. Only qualified personnel should perform troubleshooting procedures that require access to the electrical enclosure while power is on.

- 2 Turn off the water flow to the water supply line. Disconnect supply and return lines.



NOTE: If an optional flow control was added with the precooler, remove the compression fitting from the precooler inlet. Loosen the fitting on the flow control, then swing the copper water supply tube out and away from the precooler inlet.

- 3 Remove the two (2) nuts securing the precooler in the housing.



TIP: If the precooler (without a flow control) was installed using the recommended 24 inch {61 cm} of flexible hoses, there is no need to disconnect the hoses from the precooler inlet and outlet.

- 4 Remove the precooler assembly from the precooler housing.

- 5 Clean the assembly using a mild soap and water. Let the assembly dry thoroughly before installation.

- 6 Inspect the condition of the gasket. If it is damaged, replace the gasket.

- 7 Reassemble by repeating the steps in reverse order.

- 8 Connect the water supply line to the inlet. If a manual shut off valve is used, it should be mounted on the inlet line as well.

- 9 Connect the outlet of the precooler to the inlet of the flow control valve using the pre-shaped copper tubing and compression fittings provided.

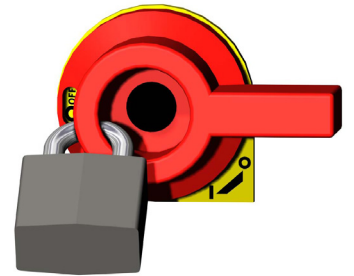

NOTE: The optional precooler is mounted to the dX cart frame.

Modbus Communications

Description of Modbus Communications

The DC-C series of products from Conair use standard TCP/IP Modbus communications protocols to allow the user to access the PLC for supervisory type functions. For example, you may want to display the drying temperature for all hoppers in a facility in one central location. By connecting all the dryers to a central computer, the temperatures and set-points can be displayed in one location using a standard SCADA software program such as Wonderware or RSView.

Installing the Modbus Communication Hardware

The hardware required for Modbus communications is included with the Ethernet option when the dryer is shipped. Connectors and cabling must be supplied by the user or ordered from Conair. Shielded category 5e Ethernet cable and connectors are recommended.

Using the Modbus Parameter List

The Modbus interface uses standard Modbus protocol to communicate with a common controls system. The data that may be retrieved is arranged in a tag name/Modbus address list. By using the Modbus register read and write commands, the desired data may be read from or written to the controller. The list of data that may be set or retrieved with the DC-C control system is arranged by Modbus register. *See Modbus Address List later in this Appendix* for the list of tag names and corresponding Modbus registers. The data types and Modbus message command types are included in the list.



CAUTION:

Writing to a location with improper data, or writing to an incorrect location outside of the specified locations on the list may cause your DC-C control system to become inoperative or to operate in a manner that may damage your process. Be certain that you understand each parameter and its effect before changing anything. Conair recommends that you initially attempt to read from the 3X registers and do not attempt any writes. Once the information you are trying to read has been confirmed as accurate, you can program your new/additional data.

Ethernet Communications

Description of Ethernet Communications

Modbus TCP/IP is a protocol that takes the basic Modbus command set that was originally developed for serial communications, and applies it to the Ethernet standard via TCP/IP protocol.

Installing the Ethernet Communication Hardware

The DC-C control is shipped with a default PLC Industrial Protocol (IP) address of 010.001.011.005. In order for your dryer to communicate with your network, this default IP address may need to be changed to match the network structure used in your plant. Changing the IP address is accomplished through a project software download or at some point after initial product release, through the operator interface terminal.

 **NOTE:** if customer specific addresses are required, they can be provided at the time of order and the dryer will ship with the Ethernet addresses preset in the dryer.

Modbus Communications (Continued)

To change the IP address:

- 1** Enter the admin password. See your dryer manual for directions if necessary.
- 2** Once the password has been entered, go to “Dryer settings”>”Dryer setup”.
- 3** First enter the new IP address, subnet mask and gateway address for the PLC.
- 4** Next enter the IP address, subnet mask and gateway address for the operator interface terminal. Also enter the OIT target IP address. Note: This is the PLC address.

Using the Ethernet Parameter List

Please refer to page Appendix A for a list of the parameters that are available with the Modbus TCP/IP interface.



CAUTION:

Writing to a location with improper data, or writing to an incorrect location outside of the specified range may cause your DC-C control system to become inoperative or to operate in a manner that may damage your process. Be certain that you understand each parameter and its effect before changing anything. Conair recommends that you initially attempt to read from the 3X registers and do not complete any writes. Once the information you are trying to read has been confirmed as accurate, you can now program in your new or additional data.



NOTE: The list of parameters that may be read and written to via Modbus TCP/IP is extensive. Some of these parameters are naturally a part of the operation of the machine and others may be obscure configuration settings. The parameter list in Appendix A includes a column with a recommendation as to whether the parameter should be accessed by a user program. Addresses that are not consecutive indicate that there are other parameters present which are not recommended for usage by the user.

Modbus Address List

Tag Name	Modbus	Type	E/U	Access	Notes
Spare	400544			RW	Spare
Spare	400545			RW	Spare
Spare	400546			RW	Spare
Gx_User_Control.	0X	BOOLS	N/A	RW	See User Structure page
Gi_User_PLC_Software_Rev	300538	INT	N/A	RO	PLC software revision, 1.00-9.99 Decimal implied
Gr_User_Dewpoint_High_Alm	400547	REAL	F/C	RW	high dewpoint alarm set point
Gu_User_DM_High_Alarm_Pos	400549	UINT	N/A	RW	Drying monitor high alarm position, 0 = T2, 1 = T3, 2 = T4, 3 = T5
Gr_User_DM_High_Alarm_SP	400550	REAL	F/C	RW	Drying monitor high alarm set point
Gu_User_DM_Low_Alarm_Pos	400552	UINT	N/A	RW	Drying monitor low alarm position, 0 = T2, 1 = T3, 2 = T4, 3 = T5
Gr_User_DM_Low_Alarm_SP	400553	REAL	F/C	RW	Drying monitor low alarm set point
Gi_User_Dryer_State_Act	300501	INT	N/A	RO	0=Powering up 1=Standby, 2=Starting 3=Stoping 4=Running, 5= Passive Alarm 6=Shutdown Alarm 7=Comms Loss 8=Cool Down
Gi_User_Dryer_Type_Act	300500	INT	N/A	RO	1=Central 2=Standard 3=MDC with conveying 4=MDC non-conveying
Gr_User_DryingMon_T1	300522	REAL	F/C	RO	Optional, drying monitor T1 temperature
Gr_User_DryingMon_T2	300524	REAL	F/C	RO	Optional, drying monitor T2 temperature
Gr_User_DryingMon_T3	300526	REAL	F/C	RO	Optional, drying monitor T3 temperature
Gr_User_DryingMon_T4	300528	REAL	F/C	RO	Optional, drying monitor T4 temperature
Gr_User_DryingMon_T5	300530	REAL	F/C	RO	Optional, drying monitor T5 temperature
Gr_User_DryingMon_T6	300532	REAL	F/C	RO	Optional, drying monitor T6 temperature
Gr_User_Energy_Hours	300516	REAL	Hours	RO	Total measurment hours
Gr_User_Energy_Last_Hour	300518	REAL	kWh	RO	Energy consumption in the last hour
Gr_User_Energy_Total_kWh	300520	REAL	kWh	RO	Total dryer kWh
Gr_User_RA_Dewpoint_Act	300536	REAL	F/C	RO	Optional return air dew point
Gi_User Loader1_Status	300541	INT	N/A	RO	0 = Disabled 1 = Enabled 2 = In Demand 3 = Loading 4 = Discharging 5 = Alarm

(Continued)

Modbus Address List (Continued)

Tag Name	Modbus	Type	E/U	Access	Notes
Gi_User_Loader2_Status	300542	INT	N/A	RO	0 = Disabled
					1 = Enabled
					2 = In Demand
					3 = Loading
					4 = Discharging
					5 = Alarm
Gr_User_Process_OnTime	300512	REAL	%	RO	Process heater % on-time
Gr_User_DeliveryAirSP_Max	400540	REAL	F/C	RW	Process temperature maximum set point
Gr_User_DeliveryAirSP_Min	400542	REAL	F/C	RW	Process temperature minimum set point
Gr_User_RA_Temp_At_Hopper_Act	300504	REAL	F/C	RO	Hopper outlet temperature
Gr_User_RA_Temp_At_Wheel_Act	300510	REAL	F/C	RO	Wheel inlet temperature
Gr_User_Regen_OnTime	300514	REAL	%	RO	Regen heater % on-time
Gr_User_Regen_Temp_Act	300506	REAL	F/C	RO	Regeneration temperature
Gr_User_Regen_TempSP_Act	300539	REAL	F/C	RO	Regen temperature set point actual
Gr_User_Spare01	300534	REAL	NA	RO	Spare real
Gr_User_SB_Reset_SP	400536	REAL	F/C	RW	Setback reset to process set point
Gr_User_SB_ReturnAir_SP	400534	REAL	F/C	RW	Setback hopper outlet set point
Gr_User_SB_Setback_SP	400532	REAL	F/C	RW	Setback to this set point
Gr_User_SB_Reset_AutoSP	300543	REAL	F/C	RO	Setback hopper outlet auto set point
Gr_User_SB_Setback_AutoSP	300545	REAL	F/C	RO	Setback to this auto calculated set point
Gx_User_Status.	1X	BOOL	N/A	RO	See User Sstructure page
Gr_User_DeliveryAir_Dewpoint_Act	300508	REAL	F/C	RO	To process dew point temperature
Gr_User_DeliveryAir_Dewpoint_SP	400538	REAL	F/C	RW	To process dew point control set point
Gr_User_DeliveryAir_Temp_Act	300502	REAL	F/C	RO	Material drying temperature
Gr_User_DeliveryAir_Temp_SP	400530	REAL	F/C	RW	Material drying temperature set point
Gx_User_Loader[1].I.Load_SP	400555	USINT	Seconds	RW	Loader 1 load time, 2-120 seconds
Gx_User_Loader[1].I.Dischrg_SP	400556	USINT	Seconds	RW	Loader 1 discharge time, 10-120 seconds
Gx_User_Loader[1].I.Purge_SP	400557	USINT	Seconds	RW	Loader 1 purge time, 2-120 seconds
Gx_User_Loader[1].I.B4_Alarm_SP	400558	USINT	Cycles	RW	Loader 1 load attempts before alarm, 0-50 cycles
Gx_User_Loader[1].I.Ratio_SP	400559	USINT	%	RW	Loader 1 regrind, 0,5-100%
Gx_User_Loader[1].I.Recvr_No	400560	USINT	NA	RW	Loader number, 1-16 for pump data in, array index
Gx_User_Loader[1].I.Pump_No	400561	USINT	NA	RW	Assigned pump number for this loader, typ 1 on a dryer
Gx_User_Loader[2].I.Load_SP	400562	USINT	Seconds	RW	Loader 1 load time, 2-120 seconds
Gx_User_Loader[2].I.Dischrg_SP	400563	USINT	Seconds	RW	Loader 1 discharge time, 10-120 seconds
Gx_User_Loader[2].I.Purge_SP	400564	USINT	Seconds	RW	Loader 1 purge time, 2-120 seconds
Gx_User_Loader[2].I.B4_Alarm_SP	400565	USINT	Cycles	RW	Loader 1 load attempts before alarm, 0-50 cycles
Gx_User_Loader[2].I.Ratio_SP	400566	USINT	%	RW	Loader 1 regrind, 0,5-100%
Gx_User_Loader[2].I.Recvr_No	400567	USINT	NA	RW	Loader number, 1-16 for pump data in, array index
Gx_User_Loader[2].I.Pump_No	400568	USINT	NA	RW	Assigned pump number for this loader, typ 1 on a dryer
GX_UserAutoStartSP[1].Day	400632	UINT	Date/Time	RW	Auto start event 1, day of the month, range 1-31
GX_UserAutoStartSP[1].Weekday	400633	UINT	Date/Time	RW	Auto start event 1, day of the week, range 1-7, Mon-Sun
GX_UserAutoStartSP[1].Hour	400634	UINT	Date/Time	RW	Auto start event 1, hour of the day, range 0-23
GX_UserAutoStartSP[1].Minute	400635	UINT	Date/Time	RW	Auto start event 1, minute of the hour, range 0-59
GX_UserAutoStartSP[7].Day	400656	UINT	Date/Time	RW	Auto start event 7, day of the month, range 1-31
GX_UserAutoStartSP[7].Weekday	400657	UINT	Date/Time	RW	Auto start event 7,day of the week, range 1-7, Mon-Sun

Modbus Address List (Continued)

Tag Name	Modbus	Type	E/U	Access	Notes
GX_UserAutoStartSP[7].Hour	400658	UINT	Date/Time	RW	Auto start event 7, hour of the day, range 0-23
GX_UserAutoStartSP[7].Minute	400659	UINT	Date/Time	RW	Auto start event 7, minute of the hour, range 0-59
GX_UserAutoStopSP[1].Day	400660	UINT	Date/Time	RW	Auto stop event 1, day of the month, range 1-31
GX_UserAutoStopSP[1].Weekday	400661	UINT	Date/Time	RW	Auto stop event 1, day of the week, range 1-7, Mon-Sun
GX_UserAutoStopSP[1].Hour	400662	UINT	Date/Time	RW	Auto stop event 1, hour of the day, range 0-23
GX_UserAutoStopSP[1].Minute	400663	UINT	Date/Time	RW	Auto stop event 1, minute of the hour, range 0-59
GX_UserAutoStopSP[7].Day	400684	UINT	Date/Time	RW	Auto stop event 7, day of the month, range 1-31
GX_UserAutoStopSP[7].Weekday	400685	UINT	Date/Time	RW	Auto stop event 7, day of the week, range 1-7, Mon-Sun
GX_UserAutoStopSP[7].Hour	400686	UINT	Date/Time	RW	Auto stop event 7, hour of the day, range 0-23
GX_UserAutoStopSP[7].Minute	400687	UINT	Date/Time	RW	Auto stop event 7, minute of the hour, range 0-59
Gr_User_StoppedHrs_Act	300794	REAL	Hours	RO	Actual time stopped after already running
Gr_User_RsdncTime_Act	300796	REAL	Hours	RO	Actual hopper residence time at (level /bulk density)
Gr_User_RsdncTime_SP	400798	REAL	Hours	RW	Material residence time set point
Gr_User_RunningHrs_Act	300798	REAL	Hours	RO	Actual time running with optimizer off

(Continued)

Modbus Address List (Continued)

Tag Name	Modbus	Type	Access	Description	.xxx Structure
Gx_User_Control.xxx	0X	BOOL	RW	HMI or Remote User Control Booleans	
	000001			Start PB	Start
	000002			Stop PB	Stop
	000003			Reserved	Spare01
	000004			Reserved	Spare02
	000005			Reserved	Spare03
	000006			Optimized recipe (0=no, 1=yes)	OptmzRcp
	000007			Engineering Units (0=english, 1=metric)	EngUnit
	000008			Reserved	Spare05
	000009			Cooldown enable (False=Disable, True=Enable)	CoolDnEn
	000010			Cooldown mode (False=Man, True=Auto)	CoolDnMode
	000011			Cooldown type (False=Time, True=Temperature)	CoolDnType
	000012			Acknowledge Alarm	AckAlarm
	000013			Energy Meter Enable	EnergyMeterEn
	000014			Dew Point Control Enable	DewPntCtrlEn
	000015			Optimizer enable	OptmzrEn
	000016			Auto Start Enable, true = enable	AutoStartEn
	000017			Auto Stop Enable, true = enable	AutoStoptEn
	000018			Spare 8	Spare08
	000019			Return Air TC Enable	AfterCoolCtrlEn
	000020			Setback Enable	SetBkCtrlEn
	000021			SetBack Mode (0=Man, 1=Auto)	SetBkMode
	000022			Network address change enable	NetChgEn
	000023			Remote expansion I/O comms enable	RemCommsEn
	000024			Save User Regen PID Gains as Default	SaveRegnDflt
	000025			Restore Default Regen PID Gains	LoadDfltRegn
	000026			Delivery air VFD communications enable	VfdCommsEn
	000027			Spare 9	Spare09
	000028			Save User Process PID Gains as Default	SaveDelAirDflt
	000029			Restore Default Process PID Gains	LoadDfltDelAir
	000031			#1 Loader enable, (True = enabled)	Recvr1En
	000032			#2 Loader enable, (True = enabled)	Recvr2En
Gb_UserAutoStartEn[1..7]	0X	Bool Array	RW	HMI or Remote user auto start enable booleans	
	000065			Monday start enable, (True = enabled)	
	000066			Tuesday start enable, (True = enabled)	
	000067			Wednesday start enable, (True = enabled)	
	000068			Thursday start enable, (True = enabled)	
	000069			Friday start enable, (True = enabled)	
	000070			Saturday start enable, (True = enabled)	
	000071			Sunday start enable, (True = enabled)	
Gb_UserAutoStopEn[1..7]	0X	Bool Array	RW	HMI or Remote user auto stop enable booleans	
	000072			Monday stop enable, (True = enabled)	
	000073			Tuesday stop enable, (True = enabled)	

Modbus Address List (Continued)

Tag Name	Modbus	Type	Access	Description	.xxx Structure
	000074			Wednesday stop enable, (True = enabled)	
	000075			Thursday stop enable, (True = enabled)	
	000076			Friday stop enable, (True = enabled)	
	000077			Saturday stop enable, (True = enabled)	
	000078			Sunday stop enable, (True = enabled)	
Gx_User_Status.xxx	1X	Bool	RO	HMI or Remote User Status Booleans	xxx Structure
	100001			Dryer (True=On not standby, False=Off or standby)	DryerOn
	100002			Reserved	Spare01
	100003			Reserved	Spare02
	100004			Auto Start (True=Enabled)	AutoStartEnabled
	100005			Auto Stop (True=Enabled)	AutoStopEnabled
	100006			SetBack Enabled	SetBkEnabled
	100007			SetBack Active	SetBkActive
	100008			Dew Point Control Active	DewPntCtrlActive
	100009			Wheel Clean Cycle Active	WhlCleanActive
	100010			Universal input 1/1 state (True=On or Ok) NEW	UI1_1
	100011			Universal input 1/2 state (True=On or Ok) NEW	UI1_2
	100012			Universal input 1/3 state (True=On or Ok) NEW	UI1_3
	100013			Universal input 1/4 state (True=On or Ok) NEW	UI1_4
	100014			Universal input 1/5 state (True=On or Ok) NEW	UI1_5
	100015			Universal input 1/6 state (True=On or Ok) NEW	UI1_6
	100016			Universal input 1/7 state (True=On or Ok) NEW	UI1_7
	100017			Universal input 1/8 state (True=On or Ok) NEW	UI1_8
	100018			Universal input 1/9 state (True=On or Ok) NEW	UI1_9
	100019			Universal input 1/10 state (True=On or Ok) NEW	UI1_10
	100020			Optimizer control enabled	OptmzrEnabled
	100021			Optimizer control active	OptmzrActive
	100022			Network settings have changed, True = Yes	NetChgActive
	100023			Remote expansion I/O communications, True = active	RemCommsActive
	100024			Hopper cool down control enabled	CoolDnEnabled
	100025			Hopper cool down cycle active	CoolDnActive
	100026			Delivery air VFD communications, True = active	VfdCommsActive
	100027			Delivery air VFD local/remote, True = remote active	VfdRemoteActive
	100028			Drying hopper low level, true = low	HopperLowLevel
	100029			Spare	Spare22
	100030			Downstream machine is running	MachRunActive
	100031			#1 Loader is enabled when true	Recvr1Enabled
	100032			#2 Loader is enabled when true	Recvr2Enabled
	100033			Universal input 2/1 state (True=On or Ok) NEW	UI2_1
	100034			Universal input 2/2 state (True=On or Ok) NEW	UI2_2
	100035			Universal input 2/3 state (True=On or Ok) NEW	UI2_3
	100036			Universal input 2/4 state (True=On or Ok) NEW	UI2_4
	100037			Universal input 2/5 state (True=On or Ok) NEW	UI2_5
	100038			Universal input 2/6 state (True=On or Ok) NEW	UI2_6

(Continued)

Modbus Address List (Continued)

Tag Name	Modbus	Type	Access	Description	.xxx Structure
	100039			Universal input 2/7 state (True=On or Ok) NEW	UI2_7
	100040			Universal input 2/8 state (True=On or Ok) NEW	UI2_8
	100041			Universal input 2/9 state (True=On or Ok) NEW	UI2_9
	100042			Universal input 2/10 state (True=On or Ok) NEW	UI2_10
	100043			Universal input 3/1 state (True=On or Ok) NEW	UI3_1
	100044			Universal input 3/2 state (True=On or Ok) NEW	UI3_2
	100045			Universal input 3/3 state (True=On or Ok) NEW	UI3_3
	100046			Universal input 3/4 state (True=On or Ok) NEW	UI3_4
	100047			Universal input 3/5 state (True=On or Ok) NEW	UI3_5
	100048			Universal input 3/6 state (True=On or Ok) NEW	UI3_6
	100049			Universal input 3/7 state (True=On or Ok) NEW	UI3_7
	100050			Universal input 3/8 state (True=On or Ok) NEW	UI3_8
	100051			Universal input 3/9 state (True=On or Ok) NEW	UI3_9
	100052			Universal input 3/10 state (True=On or Ok) NEW	UI3_10
Gb_UserAutoStartStatus[1..7]	1X	Bool Array	RO	HMI or Remote user auto start enable status bools	
	100065			Monday start enable status, (True = enabled)	
	100066			Tuesday start enable status, (True = enabled)	
	100067			Wednesday start enable status, (True = enabled)	
	100068			Thursday start enable status,, (True = enabled)	
	100069			Friday start enable status,, (True = enabled)	
	100070			Saturday start enable status,, (True = enabled)	
	100071			Sunday start enable status, (True = enabled)	
Gb_UserAutoStopStatus[1..7]	0X	Bool Array	RW	HMI or Remote user auto stop enable status bools	
	100072			Monday stop enable status, (True = enabled)	
	100073			Tuesday stop enable status, (True = enabled)	
	100074			Wednesday stop enable status, (True = enabled)	
	100075			Thursday stop enable status, (True = enabled)	
	100076			Friday stop enable status, (True = enabled)	
	100077			Saturday stop enable status, (True = enabled)	
	100078			Sunday stop enable status, (True = enabled)	

Modbus Address List (Continued)

Tag Name	Modbus	Type	Access	Element	Description
Gb_Alarms_Shutdown[xx]	1X	BOOL Array	RO	[xx]	Shutdown Alarms to the HMI or Remote user
	100101			[1]	E-stop pressed - Shutdown
	100102			[2]	E-stop or high temp - Shutdown
	100103			[3]	Process or regen heater safety switch - Shutdown
	100104			[4]	Process temperature control fault- Shutdown
	100105			[5]	Process RTD fault- Shutdown
	100106			[6]	Process blower overload- Shutdown
	100107			[7]	Process blower drive fault- Shutdown
	100108			[8]	3 phase power supply error - Shutdown
	100109			[9]	High return air temperature - Shutdown
	100110			[10]	Motor overload - Shutdown
	100111			[11]	Motor overload or phase error - Shutdown
	100112			[12]	Regen heater safety switch open - Shutdown
	100113			[13]	Regen temperature control fault - Shutdown
	100114			[14]	Regen RTD fault- Shutdown
	100115			[15]	Regen blower overload - Shutdown
	100116			[16]	PLC error detected - Shutdown
	100117			[17]	Desiccant wheel not rotating - Shutdown
	100118			[18]	Startup failed at process blower - Shutdown
	100119			[19]	Startup failed at regen blower - Shutdown
	100120			[20]	Startup failed at isolation contactor - Shutdown
	100121			[21]	Startup failed at SSRs - Shutdown
	100122			[22]	Spare
	100123			[23]	Spare
	100124			[24]	Local I/O communications fault - Shutdown
	100125			[25]	Remote I/O communications fault - Shutdown
	100126			[26]	Delivery air VFD communications fault - Shutdown
	100127			[27]	Spare
	100128			[28]	Spare
	100129			[29]	Spare
	100130			[30]	Spare
	100131			[31]	Spare
	100132			[32]	Spare
Gb_Alarms_Passive[xx]	1X	BOOL Array	RO	[xx]	Passive Alarms to the HMI or Remote
	100201			[1]	Drying monitor low temperature - Passive
	100202			[2]	Drying monitor high temperature - Passive
	100203			[3]	Clean or replace regen filter - Passive
	100204			[4]	Dewpoint high - Passive
	100205			[5]	Clean or replace process filter - Passive
	100206			[6]	Drying hopper low level - Passive
	100207			[7]	Warning, the material has been drying longer than necessary - Passive
	100208			[8]	Hopper predry settings are too low - Passive
	100209			[9]	Clean or replace filter - Passive

(Continued)

Modbus Address List (Continued)

Tag Name	Modbus	Type	Access	Element	Description
	100210			[10]	Material is ready to use - Passive
	100211			[11]	Return air dew point sensor fault - Passive
	100212			[12]	Dew point sensor fault - Passive
	100213			[13]	Return air RTD fault - Passive
	100214			[14]	Hopper outlet RTD fault - Passive
	100215			[15]	Drying monitor T1 RTD fault - Passive
	100216			[16]	Drying monitor T2 RTD fault - Passive
	100217			[17]	Drying monitor T3 RTD fault - Passive
	100218			[18]	Drying monitor T4 RTD fault - Passive
	100219			[19]	Drying monitor T5 RTD fault - Passive
	100220			[20]	Drying monitor T6 RTD fault - Passive
	100221			[21]	#1 Resin loading fault "loader name" - Passive
	100222			[22]	#1 "loader name" fill sensor fault - Passive
	100223			[23]	#1 "loader name" fill time exceeded - Passive
	100224			[24]	Spare Receiver 1
	100225			[25]	#2 Resin loading fault "loader name" - Passive
	100226			[26]	#2 "loader name" fill sensor fault - Passive
	100227			[27]	#2 "loader name" fill time exceeded - Passive
	100228			[28]	Delivery air flow sensor fault - Passive
	100229			[29]	Hopper level sensor fault - Passive
	100230			[30]	Conveying/pump overload - Passive
	100231			[31]	Hopper temp profile is in the band. Predry set points are not being used - Passive
	100232			[32]	Material exit temperature RTD fault - Passive
Gx_MaintAlert[xx].State	1X	BOOL Array	RO	[xx]	Maintenance alert triggers to the HMI or Remote
	100301			[1]	Clean or replace delivery air filter - Alert
	100302			[2]	Clean or replace regeneration air filter - Alert
	100303			[3]	Clean after cooler coils - Alert
	100304			[4]	Check delivery air heater - Alert
	100305			[5]	Check regeneration heater - Alert
	100306			[6]	Inspect desiccant rotor - Alert
Gx_MaintAlert[xx].Enable	0X	BOOL Array	RW	[xx]	Enable maintenance alerts from the HMI or Remote
	000301			[1]	Maintenance alert 1 enable
	000302			[2]	Maintenance alert 2 enable
	000303			[3]	Maintenance alert 3 enable
	000304			[4]	Maintenance alert 4 enable
	000305			[5]	Maintenance alert 5 enable
	000306			[6]	Maintenance alert 6 enable
Gx_MaintAlert[xx].Reset	0X	BOOL Array	RW	[xx]	Reset maintenance alert time or count from the HMI or Remote
	000351			[1]	Maintenance alert 1 reset
	000352			[2]	Maintenance alert 2 reset

Modbus Address List (Continued)

Tag Name	Modbus	Type	Access	Element	Description	
	000353			[3]	Maintenance alert 3 reset	
	000354			[4]	Maintenance alert 4 reset	
	000355			[5]	Maintenance alert 5 reset	
	000356			[6]	Maintenance alert 6 reset	
Gx_MaintAlert[xx]. TimeSetPoint	4X	UINT Array	RW	[xx]	Maintenance alert time set points from the HMI or Remote	
	400301				Maintenance alert 1 time (Range 8 - 80hrs)	zero disables hours
	400302				Maintenance alert 2 time (Range 8 - 80hrs)	
	400303				Maintenance alert 3 time (Range 40 - 400hrs)	
	400304				Maintenance alert 4 time (Range 160 - 2000hrs)	
	400305				Maintenance alert 5 time (Range 160 - 2000hrs)	
	400306				Maintenance alert 6 time (Range 160 - 2000hrs)	
Gx_MaintAlert[xx]. ActualHours	3X	UINT Array	RO	[xx]	Maintenance alert actual hours to the HMI or Remote	
	300301			[1]	Maintenance alert 1 actual hours	
	300302			[2]	Maintenance alert 2 actual hours	
	300303			[3]	Maintenance alert 3 actual hours	
	300304			[4]	Maintenance alert 4 actual hours	
	300305			[5]	Maintenance alert 5 actual hours	
	300306			[6]	Maintenance alert 6 actual hours	
Gx_MaintAlert[xx]. ActualMinutes	3X	UINT Array	RO	[xx]	Maintenance alert actual minutes to the HMI or Remote	
	300351			[1]	Maintenance alert 1 actual minutes	
	300352			[2]	Maintenance alert 2 actual minutes	
	300353			[3]	Maintenance alert 3 actual minutes	
	300354			[4]	Maintenance alert 4 actual minutes	
	300355			[5]	Maintenance alert 5 actual minutes	
	300356			[6]	Maintenance alert 6 actual minutes	

(Continued)

Changing the IP Address on a DC-C Dryer

- 1 Set the PLC IP address first. When the setting is changed an “apply change” push button appears.
- 2 Confirm the settings and press the “apply change” button.
- 3 To change the Ethernet settings on the DC-C dryer you will first have to login as user “admin” or higher. After logging in, access the “Dryer set-up” screen. Then press the Communication button to access the “Communication Set-up Screen”.

NOTE: When changing the Ethernet addresses, there are 3 IP address settings involved.

- (1) the actual IP address in the PLC.
- (2) that same address, as the target address in the HMI.
- (3) the actual HMI adaptor IP address.

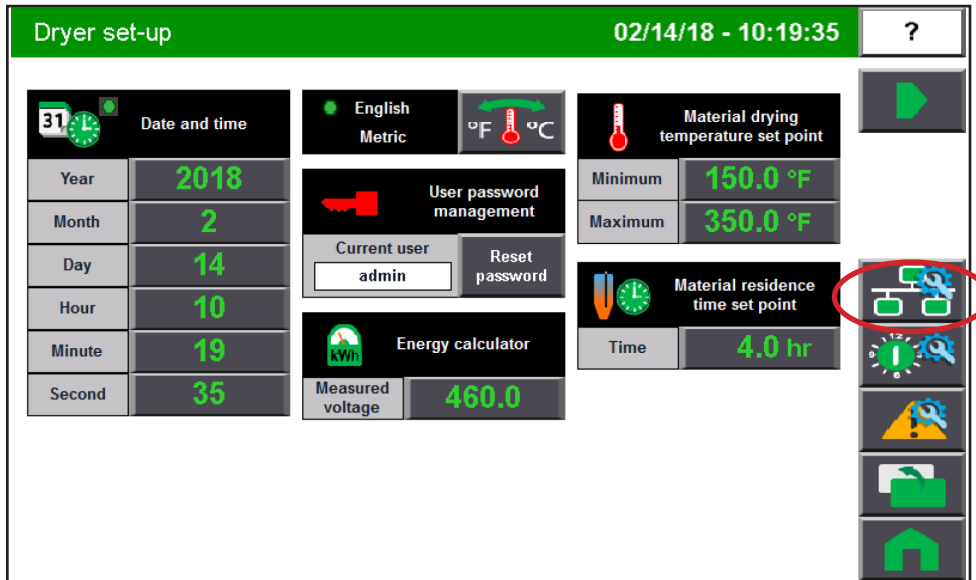

- 4 Select the PLC address. Refer to help screen instructions, following each step as shown below and on the screen.

Communications set-up screen help 02/14/18 - 11:08:09 X

Changing Ethernet settings requires the admin login. Only qualified personnel should attempt changes. Improper setting sequence or values will result in loss of communications. Always record your new settings before making any changes. Select the individual octets to change the values. Always set the PLC first!
Warning, communications will be lost after step #1 and until step #3 is completed.

Select "X" to exit the help screen

Step #3
Press this button, then on the menu select "show system settings". Under network set the new HMI IP address.

HMI Ethernet	
IP addr:	10.1.11.6
Subnet:	255.255.0.0
Gateway:	10.1.11.1
Target IP:	10.1.11.5

Step #1
Visible when settings are different. Verify new PLC settings before sending.

PLC Ethernet	
IP addr:	10.1.11.5
Subnet:	255.255.0.0
Gateway:	10.1.11.1

Visible when logged in as admin. Select to access the VNC server settings pop-up window. The VNC server is launched automatically at power-up and supports one VNC client connection. If the connection has been used but not released properly, it may be necessary to stop then start the server to free up the connection. All other settings should not be modified.

Step #2
Set the target IP to the new PLC IP address.

Drying monitor communications	
Online	●

Visible when installed. Displays the status of the I/O connection. Use the pushbutton to disable communications while servicing the drying monitor.

Delivery air VFD communications

Delivery air VFD communications	
Online	●

Visible when installed. Displays the status of the VFD connection. Use the pushbutton to disable communications while servicing the VFD.

Edit VNC

- ↩ Select to return to the dryer set-up screen.
- 🏠 Select to return to the home screen.

IMPORTANT: Follow steps in order on help screen shown.

(Continued)

Changing the IP Address on a DC-C Dryer (Continued)

- 5 On the menu select “show system settings”. Under network set the new HMI IP address.

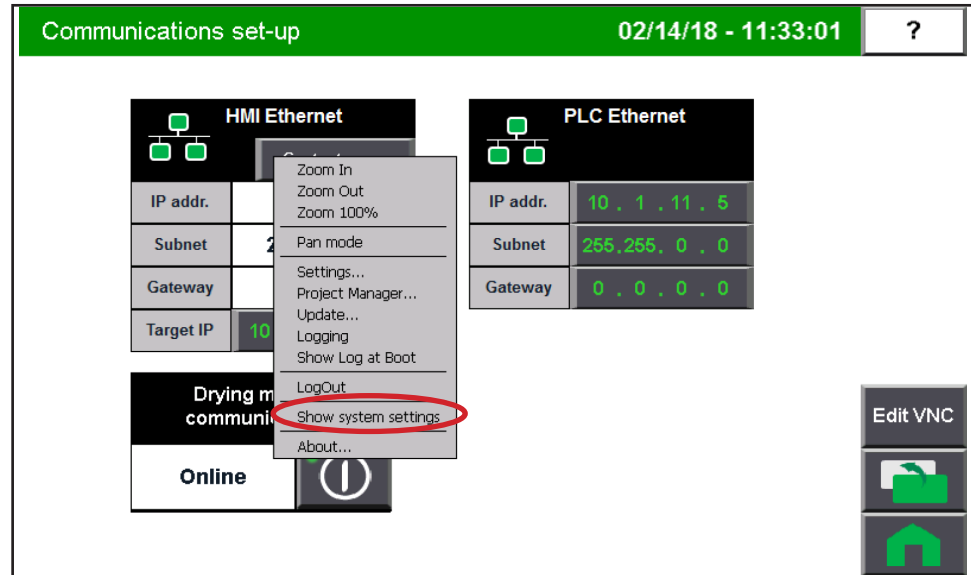

- 6 Press the “Next” button to go to the “Network Screen”.

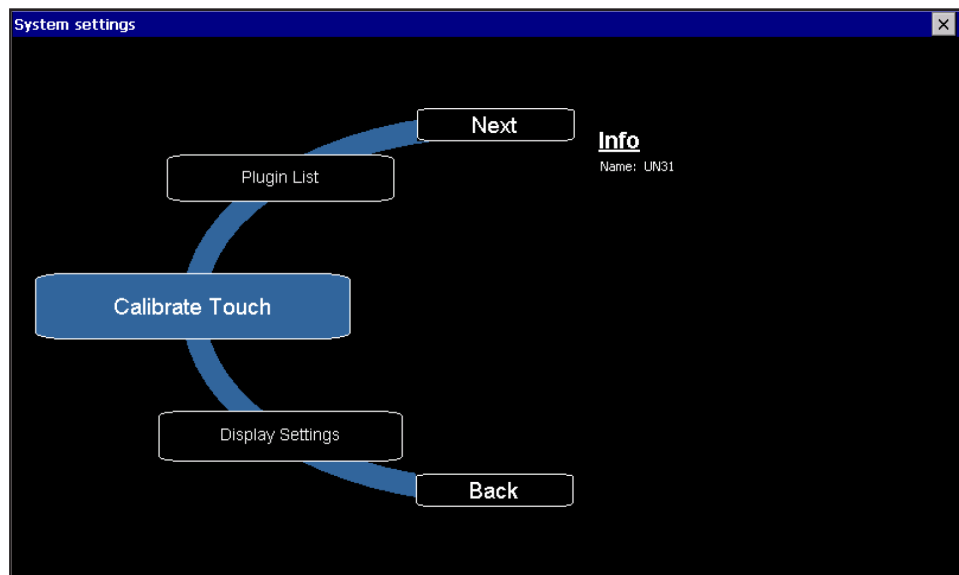

Changing the IP Address on a DC-C Dryer (Continued)

7 On the “Network Screen” Press the “Network” button. to access the “Input Panel”.

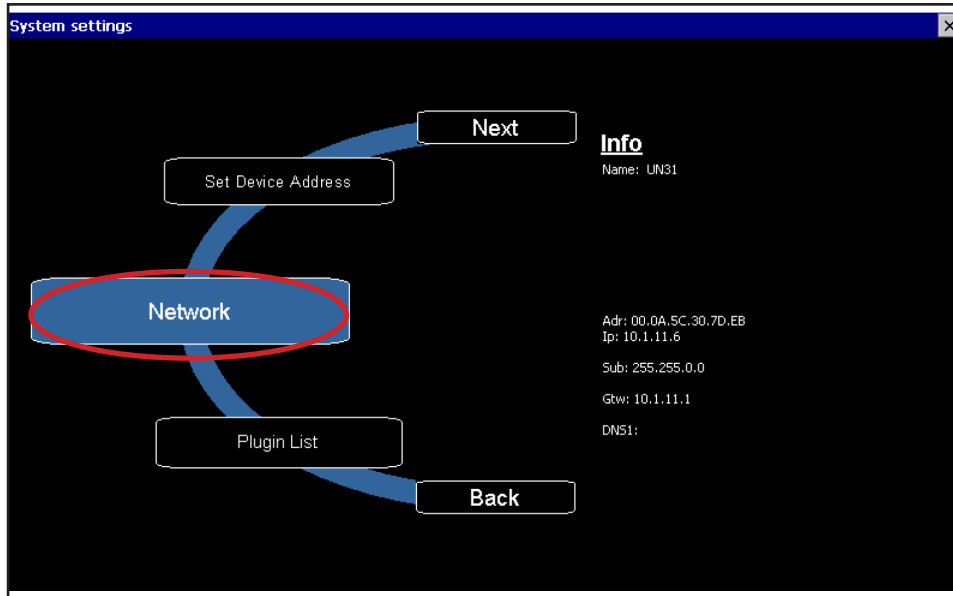

8 Enter the new IP Address.

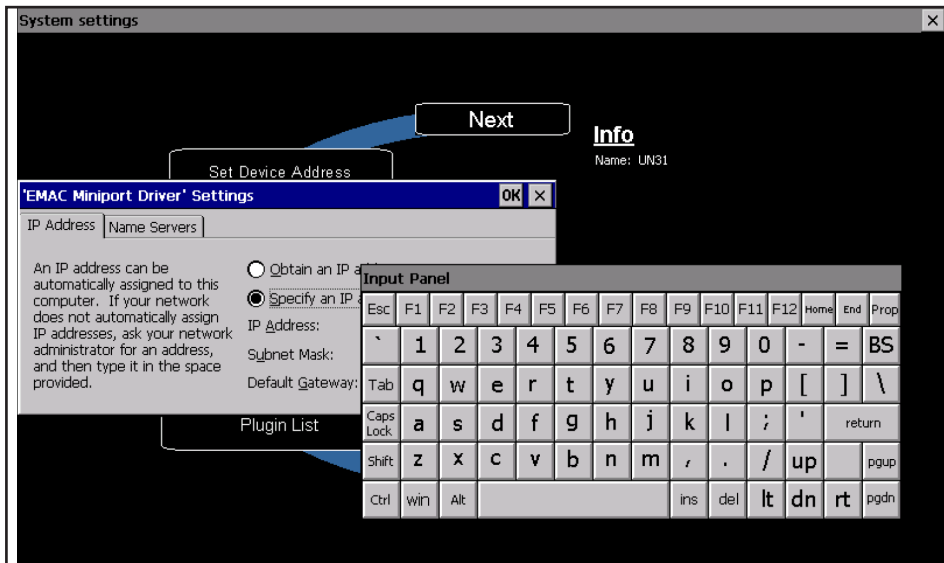

Reset VNC Connection

 **NOTE:** Refer to help screen by pressing ?

 **NOTE:** VNC only supports one connection at a time. If not shut down and released properly, stop/start is required.

IMPORTANT: Settings do not need to be changed.

The VNC server is launched automatically on power-up. **Edit VNC should only be used to stop and then restart the server when experiencing connection issues.** No other settings should be changed!

Follow these steps to reset the VNC settings for your terminal:

- 1 Go to the Communications Set-up screen and select the VNC button.

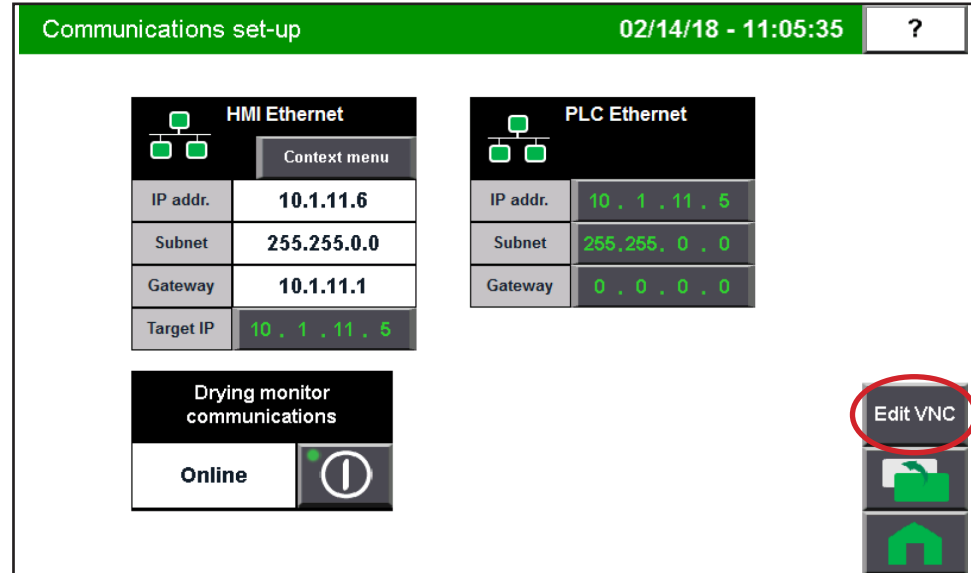

- 2 From the "Set-up Edit VNC Screen" press Options.

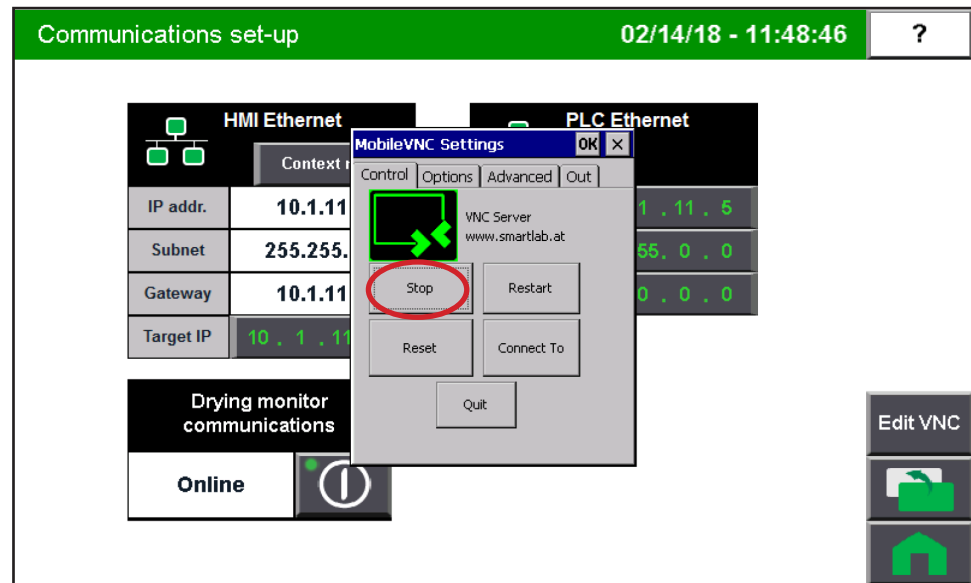

- 3 Press Stop.
- 4 Press Start (appears where Stop button was). The VNC connection is now reset.
- 5 Press OK to exit the setup.

Virtual Network Computing

Virtual Network Computing (VNC) allows you to remotely connect either over the local network or the Internet. With VNC you can interact with the terminal without having to be physically at the terminal location. It transmits keyboard and mouse actions from your computer to the terminal.

Guidelines for Using VNC

- It is recommended to enable only the view-only access to the terminal. Enabling control access increases the security risk if the password is compromised.
- Only one active VNC connection is supported and the terminal will reject additional connection requests.
- For better performance when using VNC, it is recommended to use a 100 Mbps connection. Using a 10 Mbps connection may result in lower performance, such as a slower refresh rate.
- If you are using a VNC Viewer application that supports configurable refresh rate, set the minimum refresh rate to 500 milliseconds.
- Terminate the VNC connection before performing a firmware update as it may interfere with the process.
- You cannot calibrate the touchscreen using VNC. If you have triggered the calibration process, you can press the “ESC” key on the keyboard to cancel the procedure.
- The mouse action “Press and hold” is not supported over VNC

Recommended VNC Clients and Settings

There are many VNC viewer applications you can use to connect with the terminal.

Recommended VNC Clients and Settings

Client Name	Remote Connection	Recommended Settings
Tight VNC	PC/Laptop - Windows 7	Change Preferred Encoding from “Tight” to “Hexile” for smoother screen switching.
Real VNC	Mobile and Tablet - IOS	None
	Mobile and Tablet - Android	None
	PC/Laptop - Windows 7	<ul style="list-style-type: none">• Change Color Level from “pal8” to “Full” for a clearer display.• Change Security Notification Timeout from “2500” to “0” in the client options.
Mocha VNC	Mobile and Tablet - IOS	<ul style="list-style-type: none">• Disable the “32-bit color” option in the configuration settings for a clearer display.• Disable “Zoom to Screen height” option for a better screen view.
	Mobile and Tablet - Android	<ul style="list-style-type: none">• Enable the “8-bit color” option in the configuration settings for a clearer display
	Mobile = Windows Mobile	
Ultra VNC	PC/Laptop - Windows 7	<ul style="list-style-type: none">• None

(Continued)

Virtual Network Computing (Continued)

Establish VNC Connection to the Terminal

Follow these steps to establish a VNC connection to the terminal. TightVNC Viewer is used for the following examples. Your VNC viewer application may have some difference.

- 1 Launch the VNC Viewer application.**
- 2 Enter the IP address of your terminal and click Connect.**

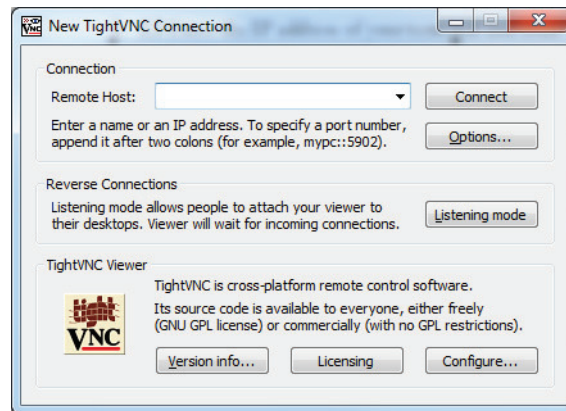

- 3 To terminate the VNC connection to the terminal, simply close the VNC Viewer application.**