

Gravimetric Precision for Material Loading

Now the precision gravimetric gain-in-weight accuracy and reliability used for decades in Conair's TrueBlend blenders can be used in conveying and loading systems. Conair's TrueRate™ is a sensing device that applies today's weighing technology to the process of loading material into a hopper, surge bin, or material storage container.

The TrueRate can be used for multiple purposes that will add current technology and eliminate the guesswork from material loading. The TrueRate gives you the ability to:

- Calculate and display the weight for each load cycle
- Tabulate the running throughput in lbs/hr {Kg/hr}
- Display the total lbs/hr {Kg/hr} usage by time period
- Convey/dose an exact amount of resin to a destination bin

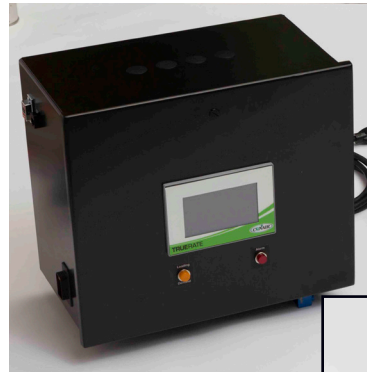

Optional 4-inch HMI for use with TrueRate.

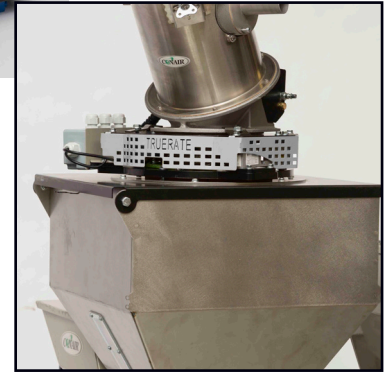

TrueRate 8
(shown with receiver above and hopper below.)

Accurate, Honest Material Usage Data - Current and Historic

How does it work? The TrueRate™ is an intelligent weigh scale to be used with a material loader/receiver. Sandwiched between a loader or receiver and a material vessel below (could be a hopper, bin, or other material storage container) the TrueRate uses digital feedback from the loader/receiver, and analog feedback from a load cell to precisely determine when a fill sequence begins and ends. Using the gravimetric weight scale, the TrueRate calculates the weight of the loader/receiver before and after the fill occurs. Calculating the time between fill cycles, an extremely accurate rate and volume of the material passing through the loader/receiver is determined and displayed by the control logic of the TrueRate.

The TrueRate can be ordered with an optional 4.3-inch color touch screen. The touch screen interface allows for locally monitoring, controlling, and configuring the system. In the absence of the operator panel, it is possible to connect using a number of remote protocols like: Modbus, Ethernet IP, or OPC-UA. VNC client applications are also possible.

▶ **Weight and throughput rate accuracy to 1%**

The tried and true gravimetric system that has provided this level of accuracy in blenders is now capable of the same levels of accuracy in your loading system. Without any sensing system, you're practically clueless to the true material use and rate of your loading system. A totalizer system offers some comfort of a measurement, but not great accuracy. The TrueRate offers complete confidence that you know exactly how much material you're using where, and at what rate.

▶ **Intuitive control with live data**

The optional 4.3-inch touch screen gives instant readings of data. No "few-minute" lag time issues here.

▶ **Save energy**

When you know your throughput rate exactly, and the precise amount of resin in a hopper, you can save energy by adjusting your drying parameters accordingly. Working smarter, not harder.

▶ **500 resin and product codes for accurate inventory and resin use**

▶ Resin codes are used to identify the resin processed by the TrueRate. There can be up to 500 different resin codes entered, with a solid density and a bulk density. The TrueRate will keep inventory totals for each resin code defined.

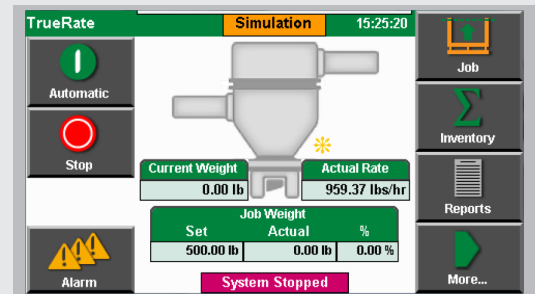

Features

- Heavy-duty construction - protects sensor units
- Communication options - connect to other systems/equipment
- Data - tracks resin totals and rates before processing
- Conair SmartServices™ and SQL reports compatible
- Load cell, gain-in-weight gravimetric accuracy to within 1%.
- Accommodates all common supply loaders/receivers (24VDC)
- Multiple load cell platform scale for maximum mechanical stability (TrueRate 8 has two load cells, TrueRate 12 has three.)
- Add the optional dosing valve to convey/dose an exact amount of material to a destination bin.

Specifications

TrueRate 8 Side View

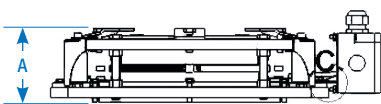

TrueRate 8 Top View

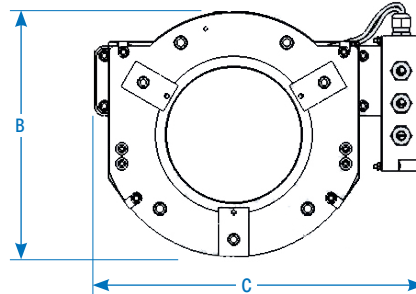

TrueRate 12 Side View

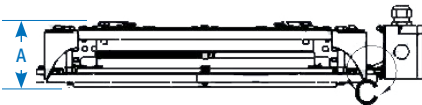

TrueRate 12 Top View

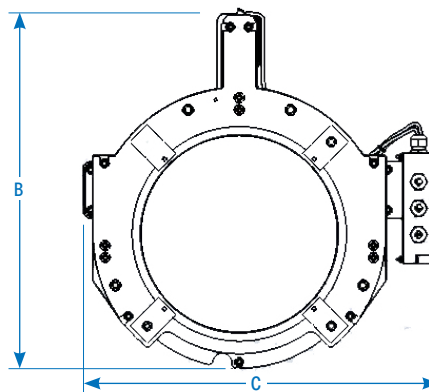

Application Notes

TrueRate is designed for indoor use only.

TrueRate is designed for use above a surge bin or other vessel so that it can determine the weight of pellets or flow-able powders dosing into that vessel.

TrueRate is not designed for applications with hoppers, vessels, or bins that can experience variable internal pressures, such as drying systems or crystallizers. It is also not designed for use on the throat of molding machines that experience motion or extreme vibration. Disturbance in the vessel through motion, pressure, or vacuum will affect the accuracy of the TrueRate and is not recommended.

Information may change without notice. Consult with a Conair representative for the most current information.

Specification Notes

* Rate is measured based on weight conveyed versus time to convey. Maximum and minimum rates shown are based on material with a bulk density of 35 lb/ft³.

Communications: Modbus, Ethernet IP, OPC-UA, VNC.

Control languages: English.

† FLA data for reference purposes only. Does not include any options or accessories on equipment. For full FLA detail for power circuit design of specific machines and systems, refer to the electrical diagrams of the equipment order and the nameplate applied to the machine.

Specifications may change without notice. Consult with a Conair representative for the most current information.

Model	TrueRate	
	TrueRate 8	TrueRate 12
Size		
Performance characteristics		
Throughput/rate*	Consult with Conair for rate	
Minimum lbs/hr (kg/hr)	Consult with Conair for rate	
Maximum lbs/hr (kg/hr)	Consult with Conair for rate	
Maximum load on unit lbs (kg)	330 {150}	495 {225}
Weigh platform dimensions inches (mm)		
A - Height	3.7 {94.0}	3.6 {91.4}
B - Width	12.3 {312.4}	21.8 {553.7}
C - Depth	16.6 {421.6}	21.8 {553.7}
Mounting interface		
Top	IT06	IT07
Bottom	IB06	IB07
Weight lb (kg)		
Shipping weight (estimated)	50 {23}	70 {32}
Voltage Full load amps †		
120V/1/60		0.8
220V/1/50		0.4
230V/1/60		0.4
Compressed air requirement	60-80 psi {4.1-5.5 bars}	



Specifications - With Optional Dosing Valve

TrueRate 8 with dosing valve
Side View

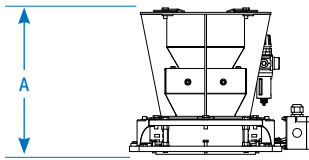

TrueRate 8 with dosing valve
Top View

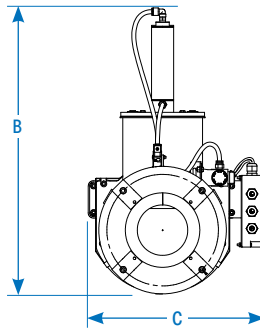

TrueRate 12 with dosing valve
Side View

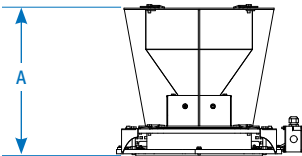

TrueRate 12 with dosing valve
Top View

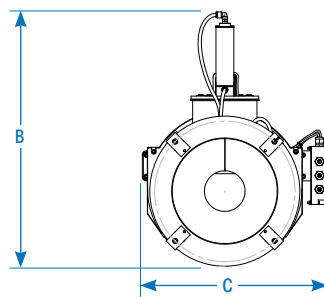

How it Works:

The optional dosing valve is designed to be used with the TrueRate to allow for measuring and dosing specific amounts of material into a bin/vessel below the TrueRate.

Adding this valve is perfect for any application where a very precise amount of material is desired for processing, eliminating material starving or flooding.

The TrueRate senses the amount of material accumulating in the vessel and uses a pneumatic cylinder to close the valve when the desired amount of material is ready for use, preventing overfilling or under-filling the vessel.

The pneumatic cylinder opens again once the TrueRate senses that it is ready for the next batch of material, and the TrueRate begins the fill sequence again.

Model	TrueRate with Dosing Valve	
Size	TrueRate 8 w/Dosing Valve	TrueRate 12 w/Dosing Valve
Performance characteristics		
Throughput/rate*		
Minimum lbs/hr {kg/hr}	Consult with Conair for rate	
Maximum lbs/hr {kg/hr} (without valve)	Consult with Conair for rate	
Maximum lbs/hr {kg/hr} (with valve)	Consult with Conair for rate	
Maximum load on unit lbs {kg}	330 {150}	495 {225}
Dimensions inches {mm}		
A - Height	13.4 {340.4}	17.7 {449.6}
B - Width	26.9 {683.2}	29.7 {754.4}
C - Depth	16.6 {421.6}	21.8 {553.7}
Mounting interface		
Top	IT06	IT07
Bottom	IB06	IB07
Weight lb {kg}		
Shipping weight (estimated)	90 {41}	120 {54}
Voltage Full load amps †		
120V/1/60	0.8	
220V/1/50	0.4	
230V/1/60	0.4	
Compressed air requirement		
	60-80 psi {4.1-5.5 bars}	

Specification Notes

* Rate is measured based on weight conveyed versus time to convey. Maximum and minimum rates shown re based on material with a bulk density of 35 lb/ft³, and no dosing valve.

Communications: Modbus, Ethernet IP, OPC-UA, VNC.

Control languages: English.

† FLA data for reference purposes only. Does not include any options or accessories on equipment. For full FLA detail for power circuit design of specific machines and systems, refer to the electrical diagrams of the equipment order and the nameplate applied to the machine.

Specifications may change without notice. Consult with a Conair representative for the most current information.