

# See-Through Hopper with Disposable Material Cone

The Conair Handy Hopper is a convenient, time-saving replacement for your machine hopper.

The Handy Hopper's clear vinyl or polycarbonate cone allows you to monitor material flow right at the machine throat. The integral slide gate and see-through cone can be removed easily with no tools.

Handy Hoppers are available in two capacities: 1.5 ft<sup>3</sup> and 3.0 ft<sup>3</sup>. Either model can be ordered with a rigid, interchangeable polycarbonate cone. The 1.5 ft<sup>3</sup> model also can be ordered with disposable vinyl hopper cones.



## Confirm Material Flow at the Machine Throat

With the Handy Hopper, you can see what's going into the process at the machine throat.

You can easily check blends or virgin/ regrind mixes and quickly spot problems, such as material bridging, that can starve the processing machine of material.

Quickly change materials or fix flow problems by simply closing the hopper slide gate and removing the entire cone/gate assembly. Access is easy. No tools required.

The Handy Hopper's rugged steel frame will support the weight of a blender or loader. A number of mounting adapter interfaces are available.

▶ **Inexpensive, replaceable cone**

The 1.5 ft<sup>3</sup> Handy Hopper comes with 5 replaceable vinyl cones or a polycarbonate cone. The 3.0 ft<sup>3</sup> hopper comes with a rigid, interchangeable polycarbonate cone.

▶ **Supports blender or loader**

The durable steel frame is rugged enough to support a blender or loader at the processing machine throat.

▶ **Fast, easy material changes**

Save time on material changes with the Handy Hopper's no-tools design, which allows you to remove the entire viewing cone and slide gate in minutes.

▶ **Optional grate magnet**

The optional grate magnet with slide gate traps metal particles in the material before they can enter the processing machine.



# Specifications



Model Part Numbers	140-032	140-123-01	140-085-01
<b>Performance characteristics</b>			
Capacity ft <sup>3</sup> {liters}	1.5		3.0
Cone material	8 mil vinyl		polycarbonate
Maximum temperature F° {C°}	100 {38}		270 {132}
<b>Dimensions inches {mm}</b>			
A - Overall height		22.75 {578}	
B - Top plate width	25 {635}		30.5 {775}
C - Top plate depth	18 {457}		24 {610}
D - Bottom plate width		10 {254}	
E - Bottom plate depth		6.5 {165}	
F - Center hole diameter	2.5 {635}		3.25 {826}
<b>Weight lb {kg}</b>			
Shipping	40 {18.14}		85 {38.56}
<b>Specification Notes</b>			
The Handy Hopper is not recommended for powdered or granular materials.			
Specifications may change without notice. Consult with a Conair representative for the most current information.			

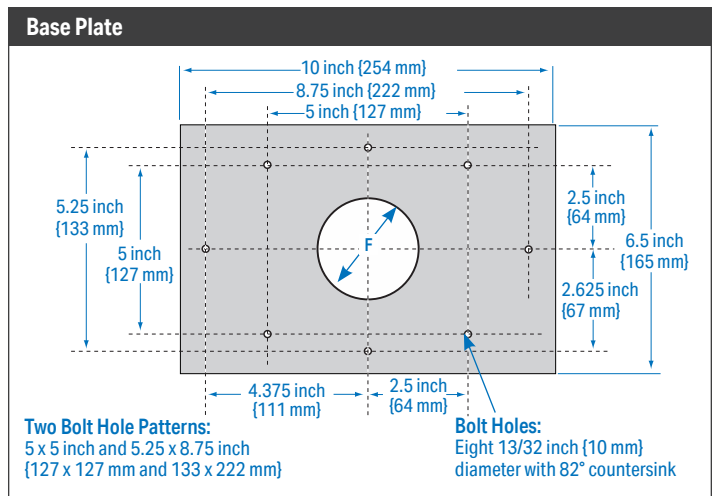
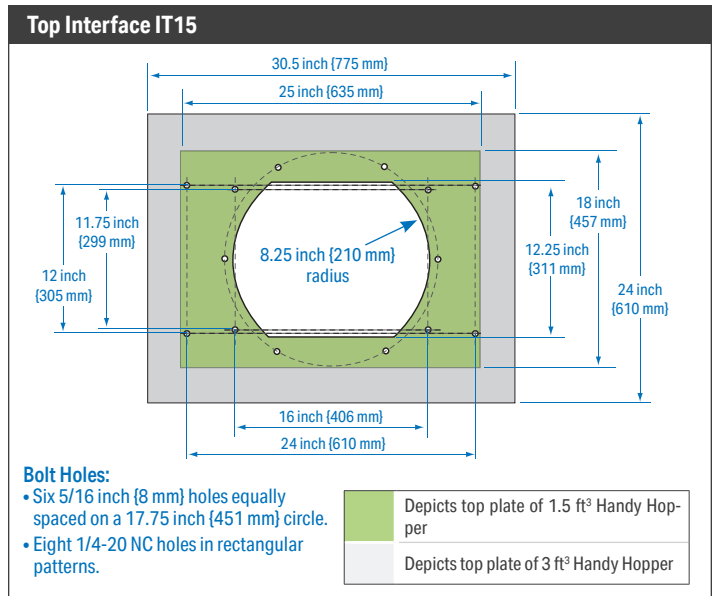

# Top Interface Adapter Kits

IB02 / IT15 (for TB45 and TB100)	IB06 / IT15 (for 8-inch gravity discharge loader)	IB07 / IT15 (for 12 to 20 inch gravity discharge loader)								
<p>Up to 3 inch {76 mm}</p>	<p>6.62 inch {168 mm}</p>	<p>12.25 inch {311 mm}</p>								
<table border="1"> <tr> <td>1.5 ft<sup>3</sup></td> <td># 613-241-01</td> </tr> <tr> <td>3.0 ft<sup>3</sup></td> <td># 613-241-01</td> </tr> </table> <p><b>Two Bolt Hole Patterns:</b>                      5 x 5 inch and 8 x 8 inch {127 x 127 mm and 203 x 203 mm}</p>	1.5 ft <sup>3</sup>	# 613-241-01	3.0 ft <sup>3</sup>	# 613-241-01	<p><b>Add adapter plate IB06IT07 to the IB07/IT15 interface for 8-inch gravity discharge loader.</b></p>	<table border="1"> <tr> <td>1.5 ft<sup>3</sup></td> <td>#102-533-01</td> </tr> <tr> <td>3.0 ft<sup>3</sup></td> <td>#B3955-01</td> </tr> </table>	1.5 ft <sup>3</sup>	#102-533-01	3.0 ft <sup>3</sup>	#B3955-01
1.5 ft <sup>3</sup>	# 613-241-01									
3.0 ft <sup>3</sup>	# 613-241-01									
1.5 ft <sup>3</sup>	#102-533-01									
3.0 ft <sup>3</sup>	#B3955-01									

