

Ultra-Low Energy Use Hybrid Chilling Technology

ECFW Series Central Chillers are designed for cooling applications between 40 and 120 tons, and utilize the ultimate in hybrid chilling technologies to achieve the lowest energy use levels ever. The combination of a hybrid film evaporator combined with an integral variable-speed drive ensure that you're only using the minimal energy you need.

Standard control is a 7-inch advanced color touch screen, for operation and monitoring. The PLC can control up to six chillers. A 10-inch or 12-inch HMI are available options. The 12-inch allows for remote access using TeamViewer on a computer or smart phone.



Model ECFW

Capacities From 40 to 120 Tons

The Conair ECFW Series Central Chillers provide up to 120 tons of cooling capacity in the most energy-efficient method available. Just a few years ago, this combination of energy-saving technology was not even available in the industry.

Combining the newest technology in variable-speed compressors with a hybrid film evaporator allows Conair's ECFW Series Chillers to maximize cooling capacity while minimizing energy use and environmental impact. A soft-start and magnetic bearings add to the mix, to reduce energy demand and noise.

Conair has a full line of equipment for all your plastics processing needs. In addition to a wide variety of heat transfer equipment (including portable chillers, towers, and Thermolators - TCUs), Conair offers entire system integration, with Conveying, Blending, Drying, Size Reduction, Material Storage, and Extrusion, along with installation and project management.

▶ Variable-speed compressor; hybrid film evaporator

Direct-drive variable-speed centrifugal compressor technology continuously adjusts the speed to match the load. Advanced design provides the most efficient heat transfer while minimizing the refrigerant charge requirement results in a compact, extremely energy-efficient combination, while extending the life of the chiller.

▶ Resilient construction and simple installation

ECFW Chillers are built in an ISO 9001-certified facility using the highest quality materials available. Magnetic "friction-free" bearings are used to extend equipment life. Oil-free operation reduces potential for contamination of the refrigerant, and compressor failure. The chiller is factory wired and piped, ready to be connected and activated upon arrival. Components are easy to access thanks to the multi-leveled galvanized steel frame.

▶ Soft-start with low noise operation

The variable-speed drive in the ECFW Chillers limits soft-starts to 2 amps inrush current per compressor. This reduces peak energy demand and extends compressor motor life. The magnetic bearings used maintain the perfect drive shaft position under high-speed operation, keeping noise levels very low.

▶ Safe and reliable operation, with available communications

Every ECFW chiller has a UL label certifying the panel design and components comply with UL 508A standards. Add a BACnet or Lon Works communications port to get a Modbus wired gateway with a RS-485 connector on the control panel. Add the 12-inch HMI with an Integral Industrial PC for remote access using a computer or smart device.



Specifications

ECFW model chillers

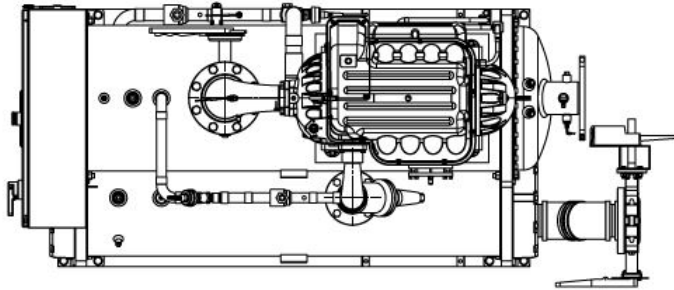

Model	ECFW-350A
Performance characteristics	
Cooling capacity** tons	40-120
Setpoint range °F {°C}	40 to 75 {4.4 to 24}
Compressors (qty)	1
Dimensions, weights, amps (chiller only)	
A - Length inches {mm}	68.7 {1745}
B - Width inches {mm}	36.1 {917}
C - Height inches {mm}	73.6 {1869}
Shipping weight lbs {kg}	3400 {1542}
Operating weight lbs {kg}	3800 {1724}
MCA @ 460/3/60 ^{††} amps	229
MOP @ 460/3/60 ^{††} amps	400

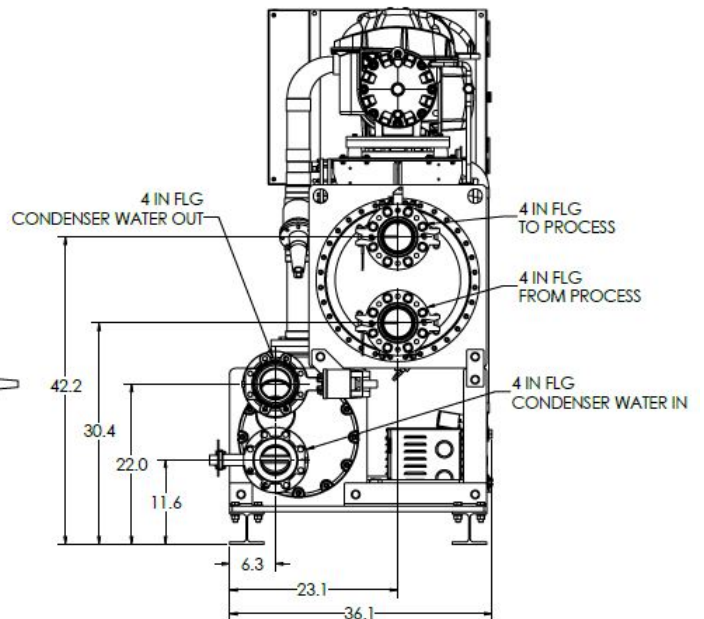
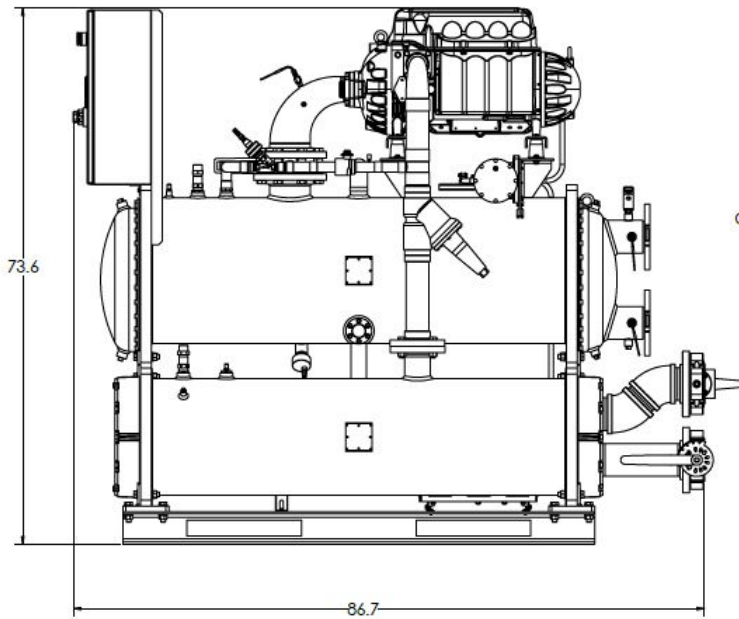

Specification Notes (see following pages)

Water-cooled models:

** Cooling capacity when cooling water with 50°F set point, 60°F return, 85°F condenser water, R-410A refrigerant.

†† MCA is minimum circuit ampacity (for wire sizing). MOP is maximum overcurrent protection, used for sizing main power protection device.

Operating weight varies based on system refrigeration charge and operating conditions.

Specifications may change without notice. Check with a Conair representative for the most current information.

