

USER GUIDE  
UGH060-0620



[www.conairgroup.com](http://www.conairgroup.com)

# EC Series Central Chillers



Thank you for purchasing Conair equipment. This manual is addressed to operators and **qualified technicians** to ensure correct use of this Conair equipment.

**ⓘ IMPORTANT: THIS MANUAL MUST BE READ BEFORE INSTALLATION. KEEP THIS MANUAL IN A PLACE ACCESSIBLE FOR ALL OPERATORS.**

Please record your equipment's model and serial number(s) and the date you received it in the spaces provided.

It's a good idea to record the model and serial number(s) of your equipment and the date you received it in the User Guide. Our service department uses this information, along with the manual number, to provide help for the specific equipment you installed.

Please keep this User Guide and all manuals, engineering prints and parts lists together for documentation of your equipment.

Date: \_\_\_\_\_

Manual Number: UGH060-0620 \_\_\_\_\_

Serial Number(s): \_\_\_\_\_

Model Number(s) \_\_\_\_\_

**DISCLAIMER:** Neither Conair nor its employees shall be liable for errors contained in this User Guide or for incidental, consequential damages in connection with the furnishing, performance or use of this information. Conair makes no warranty of any kind with regard to this information, including, but not limited to the implied warranties of merchantability and fitness for a particular purpose.

# Table of Contents

---

Foreword .....	1
Safety Guidelines .....	1
Pre-Installation.....	2
Receiving Inspection .....	2
Unit Storage.....	3
Installation - Chiller .....	3
Foundation .....	3
Unit Location .....	3
Rigging.....	3
Process Fluid Piping.....	3
Condenser Water Piping.....	3
Water Pressure Gauges.....	4
Master Temperature Sensor.....	4
Installation - Remote Condenser.....	4
Location.....	4
Lifting.....	5
Mounting Legs.....	5
Interconnecting Refrigerant Piping .....	5
Refrigeration Piping Design .....	5
Figure 1 – Condenser Located at Chiller Level.....	6
Figure 2 – Condenser Located Above Chiller Unit .....	6
Determining Equivalent Line Length .....	6
Table 1 – Equivalent Lengths of Elbows .....	6
Liquid Line Sizing.....	6
Table 2 – Liquid Line Size/Circuit .....	7
Discharge (Hot Gas) Line Sizing.....	7
Table 3 – Discharge Line Size/Circuit .....	7
Calculating Refrigerant Charge.....	7
Table 4 – Total Summertime Refrigerant Charge .....	7
Table 5 - Field Piping R-134a Refrigerant Charges.....	7
Installation - Electrical.....	8
Compressor Control Logic .....	9
Single Circuit.....	9
Dual Circuit.....	9
Master/Slave.....	9
General Control Operation .....	10
System Initialization.....	10
Figure 3 – Start-Up Splash Screen .....	10
Home - System Overview.....	10
System Overview.....	10
Figure 4 – Water-Cooled Chiller Home Screen .....	10
Figure 5 – Remote Condenser Home Screen .....	10
Table 6 – System Overview Functions .....	11

Home - Full Screen.....	11
Figure 6 – Full Screen Display Mode .....	11
Menu 1 - Overview.....	12
Figure 7 – Menu 1 Screen .....	12
Table 7 – Menu 1 Functions .....	12
Menu 1 - Alarms.....	13
Alarms Active.....	13
Figure 8 – HMI Alarm Handler .....	13
Alarm Setup .....	13
Figure 9 – Alarm Setup.....	13
Menu 1 – Circuit Details.....	13
Circuit Details Screen .....	13
Figure 10 – Circuit Details Screen (Water-Cooled Chiller) .....	13
Figure 11 – Circuit Details Screen (Air-Cooled Chiller).....	13
Circuit Details Screen – Turbocor.....	14
Figure 12 – Turbocor Screen.....	14
Circuit Details Screen – Interlocks.....	14
Figure 13 – Interlocks.....	14
Figure 14 – Critical Interlocks .....	14
Menu 1 – Circuit Demand .....	14
Circuit Demand Screen.....	14
Figure 15 – Demand Circuit.....	14
Menu 1 – Logging .....	14
Figure 16 – Logging Screen.....	14
Menu 1 – Trending.....	15
Figure 17 – Trending Screen .....	15
Menu 1 – Inputs / Outputs .....	15
Inputs / Outputs Screens.....	15
Figure 18 – Digital Inputs Screen .....	15
Figure 19 – Digital Outputs Screen .....	15
Figure 20 – Analog Outputs Screen.....	15
Figure 21 – RTD Inputs Screen.....	15
Menu 1 – Hot Gas Bypass.....	16
Hot Gas Bypass Setup Screen.....	16
Figure 22 – Hot Gas Bypass Screen.....	16
Table 8 – HGBP Setup Parameters.....	16
Menu 1 – Expansion Valve Setup .....	16
EXV Control Setup Screen.....	16
Figure 23 – EXV Control Screen.....	16
Table 9 – EXV Setup Parameters .....	16
Menu 1 – Discharge Control Setup .....	17

Discharge Control Setup Screen.....	17
Figure 24 – Discharge Control Screen.....	17
Figure 25 – Discharge Control Screen (TCR only).....	17
Table 10 – Discharge Setup Parameters.....	17
Menu 1 – Modbus Compressor(s).....	18
Compressor Modbus Screen.....	18
Figure 26 – Circuit 1 Additional Detail.....	18
Table 11 – Modbus Setup.....	18
Menu 1 – Flow / Capacity.....	18
Flow/Capacity Screen.....	18
Figure 27 – Flow / Capacity Screen.....	18
Menu 1 – Pump Control.....	19
Pump Control Screen.....	19
Figure 28 – Pump Control Screen.....	19
Table 12 – Pump Setup Parameters.....	19
Menu 1 – Staging.....	19
Compressor Staging Setup Screen.....	19
Figure 29 – Compressor Staging Screen.....	19
Table 13 – Compressor Staging Parameters.....	19
Menu 1 – Stage Order.....	20
Compressor Staging Setup Screen.....	20
Figure 30 – Compressor Stage Order Screen.....	20
Table 14 – Compressor Staging Local Parameters.....	20
Menu 2 – Overview.....	20
Figure 31 – Menu 2 Screen.....	20
Table 15 – Menu 2 Functions.....	20
Menu 2 – Defaults.....	21
Figure 32 – Restore Factory Settings.....	21
Figure 33 – Factory Settings Restored.....	21
Menu 2 – Remote Mode.....	21
Menu 2 – Modbus/BAS.....	21
Figure 34 – Modbus Setup Screen.....	21
Start-Up.....	22
Step 1 – Connect Main Power.....	22
Step 2 – Fill Coolant Circuit.....	22
System Fill Water Chemistry Requirements.....	22
Table 16 – Fill Water Chemistry Requirements.....	23
Table 17 - Recommended Glycol Solutions.....	23
Step 3 - Check Condenser.....	24
Water-Cooled Condenser Check.....	24
Remote Air-Cooled Condenser Check.....	24
Step 4 – Check Refrigerant Valves.....	24

Step 5 – Check Low Temperature Alarm.....	24
Step 6 – Turn On Control Power .....	24
Step 7 – Establish Coolant Flow.....	24
Step 8 – Initial Unit Operation.....	24
Preventive Maintenance.....	25
Once a Week .....	25
Once a Month .....	25
Once Every 6 Months.....	25
Once a Year.....	26
Once Every 5 years.....	26
Maintenance.....	26
Cleaning the Operator Interface.....	26
Troubleshooting.....	27
Drawings.....	28

## Foreword

---

The central chiller consists of a refrigeration circuit to provide cooling water to coolant.

This manual is to serve as a guide for installing, operating, and maintaining the equipment. Improper installation, operation, and maintenance can lead to poor performance and/or equipment damage. Use qualified installers and service technicians for all installation and maintenance of this equipment.

This manual is for our standard product. The information in this manual is general in nature. Unit-specific drawings and supplemental documents are included with the equipment as needed. Additional copies of documents are available upon request.

Due to the ever-changing nature of applicable codes, ordinances, and other local laws pertaining to the use and operation of this equipment, we do not reference them in this manual.

The equipment uses a hydro fluorocarbon (HFC), trade named R-407c, as a chemical refrigerant for heat transfer purposes. This chemical is sealed and tested in a pressurized system containing ASME coded vessels; however, a system failure will release it. Refrigerant gas can cause toxic fumes if exposed to fire. Place these units in a well-ventilated area, especially if open flames are present. Failure to follow these instructions could result in a hazardous condition. We recommend the use of a refrigerant management program to document the type and quantity of refrigerant in the equipment. In addition, we recommend only licensed and EPA certified service technicians work on our refrigeration circuits.

## Safety Guidelines

---

Observe all safety precautions during installation, start-up, and service of this equipment. The following is a list of symbols used in this manual and their meaning.



*General Warning*



*Electricity Warning*



*Sharp Element Warning*



*Hot Surface Warning*



*Flammable Material Warning*



*Explosive Material Warning*



*General Mandatory Action*



*Wear Eye Protection*



*Wear Protective Gloves*



*Wear Ear Protection*



*Disconnect Before Carrying Out Maintenance or Repair*



*Connect an Earth Terminal to Ground*

Only qualified personnel should install, start-up, and service this equipment. When working on this equipment, observe precautions in this manual as well as tags, stickers, and labels on the equipment.



**WARNING:** Any use or misuse of this equipment outside of the design intent may cause injury or harm.



**WARNING:** Vent all refrigerant relief valves in accordance to ANSI/ASHRAE Standard 15, Safety Code for Mechanical Refrigeration. Locate this equipment in a well-ventilated area. Inhalation of refrigerant can be hazardous to your health and the accumulation of refrigerant within an enclosed space can displace oxygen and cause suffocation.



**WARNING:** This equipment contains hazardous voltages that can cause severe injury or death.



**WARNING:** This equipment contains refrigerant under pressure. Accidental release of refrigerant under pressure can cause personal injury and or property damage.



**WARNING:** This equipment may contain fan blades or other sharp edges. Make sure all fan guards and other protective shields are securely in place.



**WARNING:** The exposed surfaces of motors, refrigerant piping, and other fluid circuit components can be very hot and can cause burns if touched with unprotected hands.



**CAUTION:** Disconnect and lock out incoming power before installing, servicing, or maintaining the equipment. Connecting power to the main terminal block energizes the entire electric circuitry of the unit. Shut off the electric power at the main disconnect before opening access panels for repair or maintenance.



**CAUTION:** Wear eye protection when installing, maintaining, or repairing the equipment to protect against any sparks, debris, or fluid leaks.



**CAUTION:** The equipment will exceed 70 dBA sound pressure at 1 meter distance and 1 meter elevation when operating. Wear ear protection as required for personal comfort when operating or working in close proximity to the chiller.



**CAUTION:** Wear protective gloves when installing, maintaining, or repairing the equipment to protect against any sparks, debris, or fluid leaks.

## Pre-Installation

### Receiving Inspection

When the unit arrives, verify the information on the unit nameplate agrees with the order acknowledgement and shipping papers. Inspect the equipment for any visible damage and verify all items shown on the bill of lading are present. If damage is evident, document it on the delivery receipt by clearly marking any item with damage as "unit damage" and notify the carrier. In addition, notify our Customer Service Department and they will provide assistance with preparing and filing freight damage claims, including arranging for an estimate on repair costs; however, filing the shipping damage claim is the responsibility of the receiving party. Do not install damaged equipment without getting the equipment repaired.

Shipping damage is the responsibility of the carrier. To protect against possible loss due to damage incurred during shipping and to expedite payment for damages, it is important to follow proper procedures and keep records. Photographs of damaged equipment are excellent documentation for your records.

Start unpacking the unit, inspect for concealed damage, and take photos of any damage found. Once received, equipment owners have the responsibility to provide reasonable evidence that the damage did not occur after delivery. Photos of the equipment damage while the equipment is still partially packed will help in this regard. Refrigerant lines can be susceptible to damage in transit. Check for broken lines, oil leaks, damaged controls, or any other major component torn loose from its mounting point.

Record any signs of concealed damage and file a shipping damage claim immediately with the shipping company. Most carriers require concealed damages be reported within 15 days of receipt of the equipment. In addition, notify our Customer Service Department and they will provide assistance with preparing and filing freight damage claims, including arranging for an estimate on repair costs; however, filing the shipping damage claim is the responsibility of the receiving party.

Chillers with an integral water-cooled ship with a full refrigerant charge. Chillers designed for use with a remote air-cooled condenser and the remote condensers themselves ship with a nitrogen holding charge. Check the remote condenser for signs of leaks prior to rigging. This will ensure no coil damage has occurred after the unit left the factory. The condenser ships with the legs removed. Mount the legs to the condenser using the provided nuts, bolts, and washers.

## Unit Storage

When storing the unit it is important to protect it from damage. Blow out any water from the unit; cover it to keep dirt and debris from accumulating or getting in, and store in an indoor sheltered area that does not exceed 145°F.

## Installation - Chiller

---

### Foundation

Install the unit on a rigid, non-warping mounting pad, concrete foundation, or level floor suitable to support the full operating weight of the equipment. When installed the equipment must be level within ¼ inch over its length and width.

### Unit Location

The unit is available in many different configurations for various environments. Refer to the proposal and order acknowledgement document for the equipment to verify the specific design conditions in which it can operate.

To ensure proper airflow and clearance space for proper operation and maintenance allow a minimum of 36 inches of clearance between the sides of the equipment and any walls or obstructions. Avoid locating piping or conduit over the unit to ensure easy access with an overhead crane or lift to lift out heavier components during replacement or service. In addition, ensure the condenser and evaporator refrigerant pressure relief valves can vent in accordance with all local and national codes.

### Rigging

The chiller has a frame to facilitate easy movement and positioning with a crane or forklift. Follow proper rigging methods to prevent damage to components. Avoid impact loading caused by

sudden jerking when lifting or lowering the chiller. Use pads where abrasive surface contact may occur.

## Process Fluid Piping

Proper insulation of chilled process fluid piping is crucial to prevent condensation. The formation of condensation adds a substantial heat load to the chiller.

The importance of properly sized piping cannot be overemphasized. See the ASHRAE Handbook or other suitable design guide for proper pipe sizing. In general, run full size piping out to the process and reduce pipe size at connections as needed. One of the most common causes of unsatisfactory chiller performance is poor piping system design. Avoid long lengths of hoses, quick disconnect fittings, and manifolds wherever possible as they offer high resistance to water flow. When manifolds are required, install them as close to the use point as possible. Provide flow-balancing valves at each machine to assure adequate water distribution in the entire system.

## Condenser Water Piping

(Water-Cooled Condenser Units Only)

The performance of a water-cooled condenser is dependent on the flow and temperature of the cooling water used. Insufficient cooling of the condenser will result in the reduction of cooling capacity of the chiller and under extreme conditions may result in the chiller shutting down due to high refrigerant pressure. Allowing the condenser to plug up from contaminants in the condenser water stream adversely affects performance. In order to reduce maintenance costs and chiller downtime, a water treatment program is highly recommended for the condenser cooling water. Contact our Customer Service Department for assistance in the proper procedure for cleaning out any plugged condenser.

The nominal water-cooled condenser is design for 85°F condenser cooling water supply. Under normal operation there will be about a 10°F rise through the condenser resulting in 95°F exiting water. To ensure proper water flow through the condenser, ensure the condenser water pump provides at least 25 psi or water at a flow rate of 3 gpm per ton of chiller capacity.

Each condenser has a two-way condenser water-regulating valve. The condenser water-regulating valve controls the amount of water allowed to pass through the condenser in order to maintain proper refrigeration pressures in the circuit.

To prevent damage to the condenser and/or water-regulating valve, the water pressure should not exceed 150 psig.

### Water Pressure Gauges

Install pressure gauges in the inlet and outlet of both the condenser and evaporator chilled water piping to provide the ability to read the pressure drop across the chiller and aid in preventive maintenance and troubleshooting.

### Master Temperature Sensor

This section only applies to installations where multiple chillers are in a common system where one chiller is the master with the other chillers serving as slaves. In those situations, a field-installed master fluid-temperature transmitter is required in the common process fluid supply and return piping. Install the sensor downstream of all individual chilled water supply streams. Position the temperature transmitter to read the mixed supply temperature. The supply temperature transmitter is normally the control sensor for the chiller system set point and determines the loading/unloading of the compressors of the system.

Mount the temperature transmitter in a 1/2" NPT coupling in a minimum pipe size of 3". The probe sheath is 1/4" OD x 3" in length and is equipped with a 1/2" NPT male fitting for direct mounting in a coupling. Use direct immersion mounting for the most accurate reading and quickest response time. If direct immersion mounting is not possible, mount the sensor inside a thermowell to aid in maintenance and or repair of the sensor if opening of the process piping is not possible. Use a suitable heat transfer compound with a thermowell. Wire from the temperature transmitter to the chiller electrical enclosure and landed at the designated terminal blocks within the enclosure. Please see the chiller electrical schematic provided for further detail.

## Installation - Remote Condenser

---

Chillers designed for use with a remote air-cooled condenser include a factory-selected remote condenser. The remote air-cooled condenser typically ships separately from a different location than the chiller.

### Location

The remote air-cooled condenser is for outdoor use. Locate the remote condenser in an accessible area. The vertical air discharge must be unobstructed. Allow a minimum of 48 inches of clearance between the sides and ends of the condenser and any walls or obstructions. For installations with multiple condensers, allow a minimum of 96 inches between condensers placed side-by-side or 48 inches for condensers placed end-to-end.

When locating the condenser it is important to consider accessibility to the components to allow for proper maintenance and servicing of the unit. Avoid locating piping or conduit over the unit to ensure easy access with an overhead crane or lift to lift out heavier components during replacement or service.

Proper ventilation is another important consideration when locating the condenser. In general, locate the unit in an area that will not rise above 110°F.

Install the unit on a firm, level base no closer than its width from walls or other condensers. Avoid locations near exhaust fans, plumbing vents, flues, or chimneys. Fasten the mounting legs at their base to the steel or concrete of the supporting structure. For units mounted on a roof structure, the steel support base holding the condenser should be elevated above the roof and attached to the building.

Avoid areas that can create a "micro-climate" such as an alcove with east, north, and west walls that can be significantly warmer than surrounding areas. The condenser needs to have unrestricted airways so it can easily move cool air in and heated air away. Consider locating the condenser where fan noise and vibration transmission into nearby workspaces is unlikely.

The unit ships on its side with the legs removed to reduce shipping dimensions and provide more

protection to the coil from possible damage caused by impact loading over rough roads and transit conditions.

## Lifting

Lift the remote condenser using the leg support channels or the side lifting brackets for larger units. It is best to attach the unit mounted leg assemblies when the unit is flat, fans facing up, and when supported by the rigging. Take special care not to bump, hit, or otherwise stress the tubing, headers, or connections during the lifting and positioning of the unit. Under no circumstances use the coil headers or return bends in the lifting or moving of the condenser.

## Mounting Legs

Before rigging the unit, install the legs using the hardware provided. The standard legs are 22 inches. Optional 48 or 60 inches legs require a leg between every fan section and gusset for stability. 60 inch legs also require cross bracing, see the diagram provided with the unit for details. The following shows a typical leg mounting arrangement.

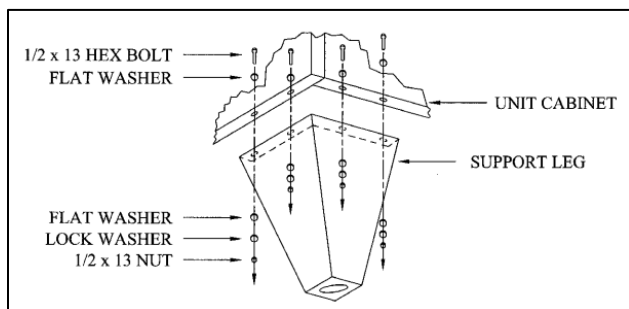

## Interconnecting Refrigerant Piping

The chiller and remote condenser ship with a nitrogen holding charge. Evacuation of this charge is required before charging with refrigerant. The chiller is for use only with the air-cooled condenser provided with the unit. The following section covers the required piping between the chiller and the provided air-cooled condenser.

The discharge and liquid lines leaving the chiller have caps. These line sizes do not necessarily reflect the actual line sizes required for the piping between the chiller and the air-cooled condenser.

Refrigerant piping size and piping design have a significant impact on system performance and

reliability. All piping should conform to the applicable local and state codes.



**CAUTION:** Use refrigerant grade copper tubing ASTM B280 only and isolate the refrigeration lines from building structures to prevent transfer of vibration. All copper tubing must have a pressure rating suitable for R-134a; tubing must be Type L rigid tubing.

Do not use a saw to remove end caps. This might allow copper chips to contaminate the system. Use a tube cutter or heat to remove the caps. When sweating copper joints it is important to evacuate all refrigerant present and flow dry nitrogen through the system. This prevents the formation of toxic gases, corrosive acids, and scale.



**CAUTION:** Do not use soft solders. For copper-to-copper joints use a copper-phosphorus braze alloy (BCuP per the American Welding Society) with 5% (BCuP-3) to 15% (BCuP-5) silver content. Only use a high silver content brazing alloy (BAg per AWS) for copper-to-brass or copper-to-steel joints such as a 45% (BAg-5) silver content. Only use oxy-acetylene brazing when soldering refrigerant piping.

## Refrigeration Piping Design

The system is configurable as shown in Figure 1 and Figure 2. The configuration and its associated elevation, along with the total distance between the chiller and the air-cooled condenser, are important factors in determining the liquid line and discharge line sizes. This will also affect the field refrigerant charges. Consequently, it is important to adhere to certain physical limitations to ensure the system operates as designed.

### General Design Considerations

1. The total distance between the chiller and the remote air-cooled condenser must not exceed 100 equivalent feet. Keep the distance as short as possible.
2. Liquid line risers must not exceed 15 feet in height from the condenser liquid line connection.
3. Discharge line risers cannot exceed an elevation difference greater than 85 actual feet or 100 equivalent feet without a minimum of 2% efficiency decrease.
4. To form a proper liquid seal at the condenser, immediately drop at least 15 inches down from the liquid outlet before routing the piping to the chiller. Make the drop leg before any bends or

- angles connecting to the remainder of the liquid connection piping.
- Position the condenser at the same elevation or above the chiller.
  - Pipe condensers with dual circuits to assure equal refrigerant flow to each circuit.

Figure 1 – Condenser Located at Chiller Level

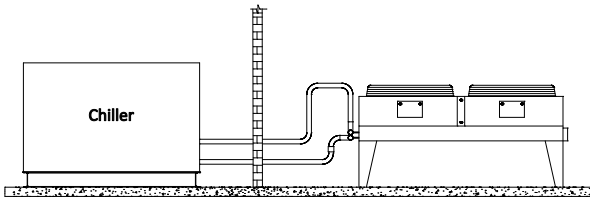
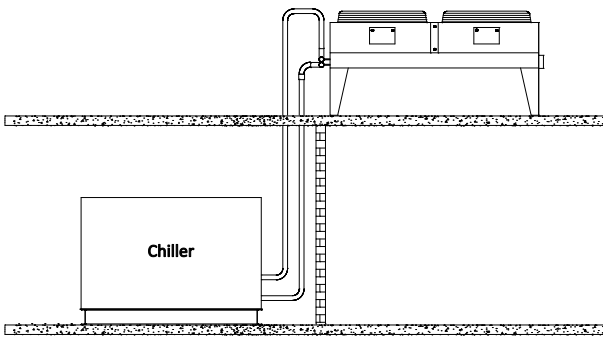

Figure 2 – Condenser Located Above Chiller Unit



Note: Liquid line sizing for each chiller capacity is in Table 2. These line sizes are listed per circuit and apply where leaving water temperature (LWT) is 40°F or higher. For applications where the LWT is below 40°F, size lines using the ASHRAE Refrigeration Handbook or other suitable design guide.

### Determining Equivalent Line Length

To determine the appropriate size for field installed liquid and discharge lines, it is first necessary to establish the equivalent length of pipe for each line. The equivalent length is the approximate friction loss from the combined linear run of pipe and the equivalent feet of elbows, valves, and other components in the refrigeration piping. The sum total is the equivalent length of pipe that would have the same pressure loss. See the ASHRAE Refrigeration Handbook for more information.

#### Follow these steps when calculating line size

- Start with an initial approximation of equivalent length by assuming that the equivalent length of pipe is 1.5 times the actual pipe length.

- Determine approximate line sizes by referring to Table 2 for liquid lines and Table 3 for discharge lines.
- Check the line size by calculating the actual equivalent length using the equivalent lengths as shown in Table 1.



CAUTION: When calculating the equivalent length, do not include piping of the chiller unit. Only field piping must be considered.

Table 1 – Equivalent Lengths of Elbows

Line Size OD (in)	Equivalent Lengths of Refrigerant Pipe (feet)				
	90° Standard	90° Long Radius	90° Street	45° Standard	45° Street
7/8	2.0	1.4	3.2	0.9	1.6
1 1/8	2.6	1.7	4.1	1.3	2.1
1 3/8	3.3	2.3	5.6	1.7	3.0
1 5/8	4.0	2.6	6.3	2.1	3.4
2 1/8	5.0	3.3	8.2	2.6	4.5
2 1/8	6.0	4.1	10.0	3.2	5.2
3 1/8	7.5	5.0	12.0	4.0	6.4
3 5/8	9.0	5.9	15.0	4.7	7.3
4 1/8	10.0	6.7	17.0	5.2	8.5

### Liquid Line Sizing

The liquid line diameter should be as small as possible while maintaining acceptable pressure drop. This is necessary to minimize refrigerant charge. The total length between the chiller unit and the air-cooled condenser must not exceed 85 actual feet or 100 equivalent feet. It is best to pipe the liquid line so that there is an immediate drop of at least 15 inches at the condenser outlets to make a liquid seal.

Liquid line risers in the system will require an additional 0.5 psig pressure drop per foot of vertical rise. When it is necessary to have a liquid line riser, make the vertical run immediately after the condenser before any additional restrictions. The liquid line risers must not exceed 10 feet in height from the condenser liquid line connection. The liquid line does not require pitching. Install a pressure tap valve at the condenser to facilitate measuring pressure for service.

Liquid lines do not typically require insulation. However, if exposing the lines to solar heat gain or temperatures exceeding 110 °F, there is a negative effect on sub-cooling. In these situations, insulate the liquid lines.

**Table 2 – Liquid Line Size/Circuit (inches OD)**

Total Equivalent Length (Ft)	60 Ton	70 Ton	80 Ton	90 Ton	100 Ton	120 Ton
25	1 3/8	1 5/8	1 5/8	1 5/8	2 1/8	2 1/8
50	1 5/8	1 5/8	2 1/8	2 1/8	2 1/8	2 1/8
75	1 5/8	2 1/8	2 1/8	2 1/8	2 1/8	2 1/8
100	2 1/8	2 1/8	2 1/8	2 1/8	2 1/8	2 1/8

### Discharge (Hot Gas) Line Sizing

The discharge line size is determined based on a pressure drop corresponding to a 2°F or less change in saturation temperature. It is important to minimize the line length and restrictions to reduce pressure drop and maximize capacity and efficiency.

The discharge lines should pitch downward, in the direction of the hot gas flow, at the rate of ½ inch per each 10 feet of horizontal run. If the chiller unit is below condenser, loop the discharge line to at least 1 inch above the top of the condenser. Install a pressure tap valve at the highest point of the hot gas line into the condenser to facilitate removal of inadvertently trapped non-condensable material.



*Note: Discharge line sizing for each chiller circuit capacity is in Table 3. Line sizing shown is listed per circuit and applies where leaving water temperature (LWT) is 40°F or higher. For applications where LWT is below 40°F, size lines using the ASHRAE Refrigeration Handbook or other suitable design guide.*

**Table 3 – Discharge Line Size/Circuit (inches OD)**

Total Equivalent Length (Ft)	60 Ton	70 Ton	80 Ton	90 Ton	100 Ton	120 Ton
25	2 1/8	2 1/8	2 1/8	2 1/8	2 5/8	3 1/8
50	2 1/8	2 5/8	2 5/8	2 5/8	2 5/8	3 1/8
75	2 5/8	2 5/8	2 5/8	2 5/8	2 5/8	3 1/8
100	2 5/8	2 5/8	2 5/8	3 1/8	3 1/8	3 1/8

### Calculating Refrigerant Charge

To determine the approximate charge, first refer to Table 4 and establish the required charge for the condenser and chiller. Then refer to Table 5 to determine the charge required for the field-installed piping per circuit. The approximate charge per circuit is therefore the sum of the values from Table 4 and Table 5.

The charge required for an air-cooled condenser using fan cycling and variable speed for head pressure control is indeterminate due to site and environmental variances. Because refrigerant density increases with decreasing temperatures, the low

ambient operating charge is more (compared to the summer charge). In the worst case of -20°F, the charge may nearly double. The best way to assure proper charging is, on the coldest day of the year under full load, the charge should be up to the second sight glass from the bottom of the receiver with the electric expansion valve (EXV) sight glass clear. Prolonged periods of foaming in the sight glass may indicate a low refrigerant condition or a restriction in the liquid line.

*Note: Occasional bubbling in a sight glass may occur at a time when load conditions are changing and the expansion valve is adjusting to the new conditions. This momentary occurrence is a result of normal chiller operation.*

Use the sight glass to check if there is moisture in the refrigeration circuit. If there is moisture in the circuit, the green ring around the perimeter of the sight glass will turn yellow. If this occurs, service immediately.

**Table 4 – Total Summertime Refrigerant Charge**

Model Chiller	Refrigerant Charge (Lbs. of 134a @ 60°F) Combined Total of Chiller & Condenser
ECR300C	161
ECR300D	188
ECR300H	146
ECR350K	167
ECR350Q	223
ECR350S	265
ECR600C	321
ECR600D	376
ECR600H	293
ECR700K	335
ECR700Q	446
ECR700S	530

**Table 5 - Field Piping R-134a Refrigerant Charges**

Line Size OD (inches)	Discharge Line	Liquid Line
1 3/8	3.0	63.4
1 5/8	4.2	89.7
2 1/8	7.4	156.9
2 5/8	11.4	242.5
3 1/8	16.3	345.6

## Installation - Electrical

All wiring must comply with local codes and the National Electric Code. Minimum circuit amps (MCA) and other unit electrical data are on the unit nameplate. A unit specific electrical schematic ships with the unit. Measure each leg of the main power supply voltage at the main power source. Voltage must be within the voltage utilization range given on the drawings included with the unit. If the measured voltage on any leg is not within the specified range, notify the supplier and correct before operating the unit. Voltage imbalance must not exceed two percent. Excessive voltage imbalance between the phases of a three-phase system can cause motors to overheat and eventually fail. Voltage imbalance is determined using the following calculations.

$$\% \text{ Imbalance} = (V_{\text{avg}} - V_x) \times 100 / V_{\text{avg}}$$

$$V_{\text{avg}} = (V_1 + V_2 + V_3) / 3$$

$V_x$  = phase with greatest difference from  $V_{\text{avg}}$

For example, if the three measured voltages were 442, 460, and 454 volts, the average would be:

$$(442 + 460 + 454) / 3 = 452$$

The percentage of imbalance is then:

$$(452 - 442) \times 100 / 452 = 2.2 \%$$

This exceeds the maximum allowable of 2%.

There is a terminal block for main power connection to the main power source. The main power source should be connected to the terminal block through an appropriate disconnect switch. There is a separate lug in the main control panel for grounding the unit. Check the electrical phase sequence at installation and prior to start-up. Operation of the compressor with incorrect electrical phase sequencing will result in mechanical damage to the compressors. Check the phasing with a phase sequence meter prior to applying power. The proper sequence should read "ABC" on the meter. If the meter reads "CBA", open the main power disconnect and switch two line leads on the line power terminal blocks (or the unit mounted disconnect). Do not interchange any load leads that are from the unit contactors or the motor terminals.



**WARNING:** This equipment contains hazardous voltages that can cause severe injury or death.



**WARNING:** This equipment contains refrigerant under pressure. Accidental release of refrigerant under pressure can cause personal injury and or property damage.



**WARNING:** This equipment may contain fan blades or other sharp edges. Make sure all fan guards and other protective shields are securely in place.



**WARNING:** The exposed surfaces of motors, refrigerant piping, and other fluid circuit components can be very hot and can cause burns if touched with unprotected hands.



**CAUTION:** Disconnect and lock out incoming power before installing, servicing, or maintaining the equipment. Connecting power to the main terminal block energizes the entire electric circuitry of the unit. Electric power at the main disconnect should be shut off before opening access panels for repair or maintenance.



**CAUTION:** Wear eye protection when installing, maintaining, or repairing the equipment to protect against any sparks, debris, or fluid leaks.



**CAUTION:** Wear protective gloves when installing, maintaining, or repairing the equipment to protect against any sparks, debris, or fluid leaks.



**CAUTION:** Wire the unit ground in compliance with local and national codes.

## Compressor Control Logic

---

### Single Circuit

A single circuit chiller contains only one compressor. The chiller controls the leaving chilled water according to the chilled water set point. A temperature sensor is field installed in the supply water at the exit of the chiller and sends information to the PLC. When the temperature rises above the set point, the PLC will start the compressor when there is enough process heat load to support the operation of the compressor. The compressor, once running, will modulate its capacity to precisely control the process water temperature. If the process heat load drops below the minimum loading capability of the compressor, the compressor will cycle off. Operation of the compressor will resume once adequate heat load exists.

### Dual Circuit

A dual circuit chiller contains two compressors with two independent refrigeration circuits. Each circuit is capable of operating independently with the other circuit disabled or as a pair in a lead/lag configuration.

The chiller controls the leaving chilled water according to the chilled water set point. A temperature sensor is field installed in the supply water at the exit of the chiller and sends information to the PLC. When the temperature rises above the set point, the PLC will start the lead compressor when there is enough process heat loads to support the operation of one compressor. The lead compressor, once running, will modulate its capacity to control the supply water temperature. If the process heat load drops below the minimum loading capability of the lead compressor, the compressor will cycle off. Operation of the lead compressor will resume once adequate heat load exists.

The lag compressor will start if the process heat load continues to increase after the lead compressor is running and fully loaded. Both compressors will share the load and modulate their capacities in order to maintain the chilled water set point. If the process heat load drops to a level that one or both compressors are running at their minimum loading capability, the lag compressor will shut off. The lead compressor will then increase its capacity in order to handle the process heat load of the two previously

running compressors. If the process heat load increases, the lag compressor will resume operation only once there is enough load to require both compressors to run at a capacity greater than their minimum loading capability.

The PLC controls the designation of the lead and lag compressors. When the PLC is in Auto Lead/Lag configuration, the lead circuit will switch on regular intervals to provide equal run time on each compressor.

### Master/Slave

It is possible to link together multiple chillers to form a single system, using single or dual compressor chillers with a maximum of six compressors connected. Any chiller can be setup to be a master or a slave. The master chiller controls the staging order of the compressors and the running demand of all the compressors in the system in order to maintain the common chilled water set point. A slave chiller becomes dependent on the master only for its compressor staging order and running demand. The slave chiller PLC performs all other operations. The chilled water piping must be manifold together and the supply sensor must be positioned downstream of all individual chilled water streams to read a mixed water temperature. Wire the supply and return water temperature sensors in the common return chilled water piping to the chiller PLC designated as the master.

## General Control Operation

### System Initialization

Upon power-up, the first screen to appear is the Start-up Splash Screen. This screen will display while the Programmable Logic Controller (PLC) and Human-Machine Interface (HMI) establish communications. The control system version is located on this start-up screen.

Figure 3 – Start-Up Splash Screen



Once the HMI has completed its power on sequence and PLC to HMI communication is established, the HMI should automatically switch to the Home screen as shown in Figure 4 for water-cooled condenser chillers and Figure 5 for remote air-cooled condenser chillers.

## Home - System Overview

### System Overview

The System Overview Screen provides an overall synopsis of the chiller system. It also provides quick links to other views as well as additional useful information.

Figure 4 – Water-Cooled Chiller Home Screen

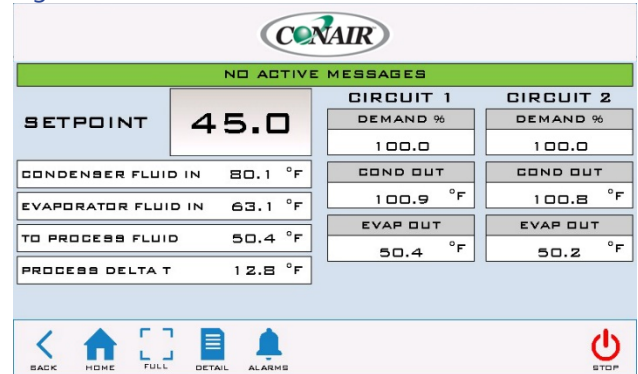

Figure 5 – Remote Condenser Home Screen

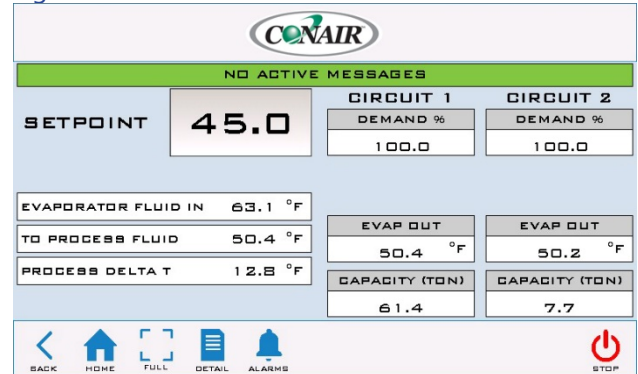

Table 6 – System Overview Functions

Function	Description	Screen Reference
Alarm Messaging	Provides information about any warnings or alarms which may have occurred.	N/A
Setpoint	This is the Set Point temperature. Touch the temperature to change. An authorized security level password is required to enter a new Setpoint.	N/A
Evaporator Fluid In	This is the chiller entering fluid temperature.	N/A
To Process Fluid	This is the chiller leaving fluid temperature.	N/A
Process Delta T	This is the difference between entering and leaving temperatures.	N/A
Demand %	This shows the actual demand requested by the compressor.	N/A
Evap Out	This shows the Evaporator leaving coolant temperature.	N/A
Menu Button	Touching this button navigates to the Menu 1 screen.	Figure 7 Figure 13
Full Screen Display	Pressing this button displays the set point and process temperatures in a large font.	Figure 6
Alarms Button	A listing of active and prior alarm history	Figure 8 Figure 9
Detail	Provide additional circuit and compressor information.	Multiple
Start/Stop	Pressing the green Start button to start the chiller and any slave units connected to the chiller. Once started, the Start button disappears. Pressing the red stop button to stop the chiller and any slave units connected to the chiller.	N/A

## Home - Full Screen

The Full Screen (Figure 6) provides a simplified view of the EC Chiller. The SETPOINT and PROCESS temperatures display in a large font easily seen from a distance, providing a “quick glance” look to validate proper operation.

Figure 6 – Full Screen Display Mode

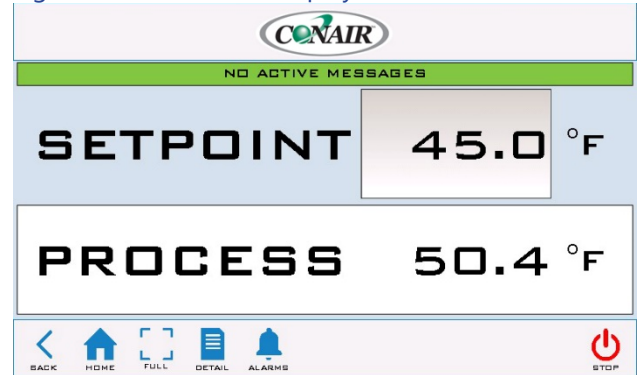

Pressing the SETPOINT value shown will allow for quick set point modification. Once the new set point has been entered press the Enter button to confirm set point. Proper security level must be valid prior to entering a new set point.

## Menu 1 - Overview

The Menu 1 Screen (Figure 7) provides a common location for most setting adjustments. Some parameters are password protected. The main user-level password is 9999 used for gaining access to changing the main system set point and various other warning and alarm settings. A few higher-level areas require a high-level user password that is 7720. If you are attempting to access an area where neither of these passwords is accepted, you may require a technician level password. For access to these areas of the program, contact our Customer Service Department for assistance.

Figure 7 – Menu 1 Screen

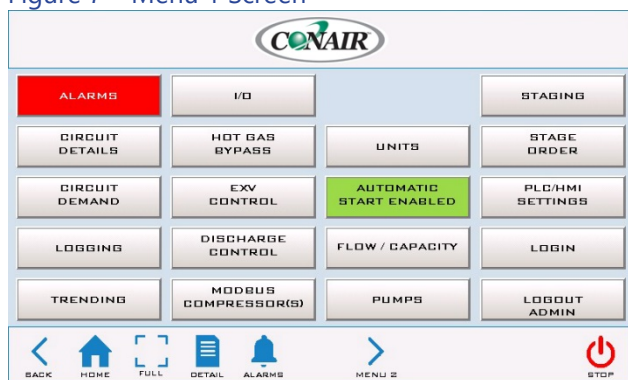

Table 7 – Menu 1 Functions

Function	Description	Screen Reference
Alarms	A listing of all active, history, and frequency of system alarms.	Figure 8 Figure 9
Circuit Details	Additional circuit and compressor related information	Figure 10 Figure 11 Figure 12
Circuit Demand	Shows the circuit demand	Figure 15
Logging	Start / Stop logs data / alarm and export to thumb drive	Figure 16
Trending	Graphical display of critical process values	Figure 17
Input / Output	The Input / Output screens provide the status of all digital inputs, outputs, RTD inputs and analog outputs.	Figure 18 Figure 19 Figure 20 Figure 21
Hot Gas Bypass	Hot Gas Bypass Setup (Load Balance Valve) (Optional)	Figure 22
EXV Control	Electric Expansion Valve Setup	Figure 23
Discharge Control	Water Regulating Valve Setup (Discharge Pressure Control)	Figure 24 Figure 25
Modbus Compressor(s)	This shows the Modbus communication status and parameters.	Figure 26
Units	Imperial or Metric units can be selected directly from this screen. Touch the UNITS button to toggle the selection between Imperial or Metric units	N/A
Auto Start	Touch this button to enable or disable the automatic start. If the option is enable, the chiller is set to start automatically.	N/A
Flow / Capacity	Provides information about the process fluid flow.	Figure 27
Pumps	This shows the configuration of the pumps and timers.	Figure 28
Staging	Compressor staging options.	Figure 29
Stage Order	Stage order setup.	Figure 30
PLC / HMI Settings	IP addresses HMI and PLC Setup	N/A
Login	Touch this button to access the different user-level.	N/A
Logout	Sign out session.	N/A

# Menu 1 - Alarms

## Alarms Active

When a critical system fault occurs, the controller activates the HMI alarm handler (Figure 8). The alarm screen will display the current faults. To silence this alarm, press the ALARM SILENCE button. If multiple alarms are active at once, use the DOWN and UP buttons to view all alarms. When no alarms are active, the white portion of the display will be blank. All alarms must be resolved and reset using the RESET ALARM button.

Figure 8 – HMI Alarm Handler

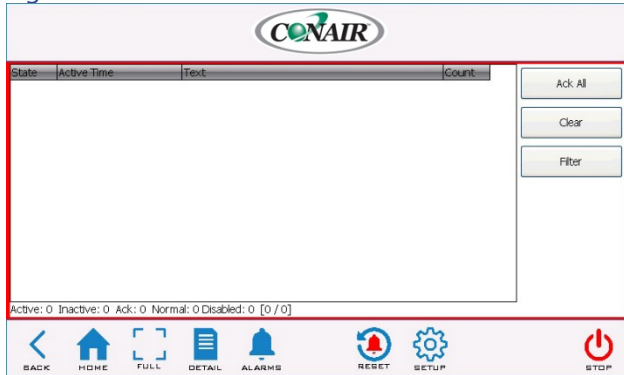

Note: The above shows there are no alarms; if an alarm condition were present, it would appear in this window.

## Alarm Setup

Alarm set points and timers are modifiable on this screen.

Figure 9 – Alarm Setup

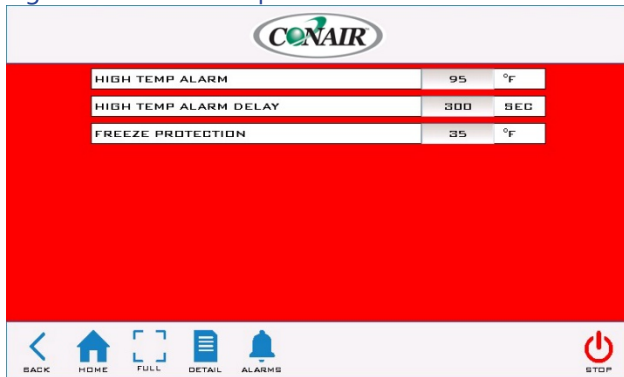

# Menu 1 – Circuit Details

## Circuit Details Screen

To access the Circuit Details Screen (Figure 10 and Figure 11) use Menu 1 (Figure 7) or touch the option Details on the Home Screen (Figure 4 or Figure 5). This screen provides additional information relative to the circuit.

Figure 10 – Circuit Details Screen (Water-Cooled Chiller)

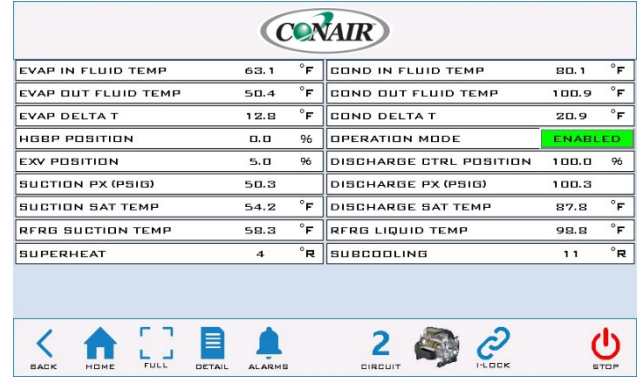
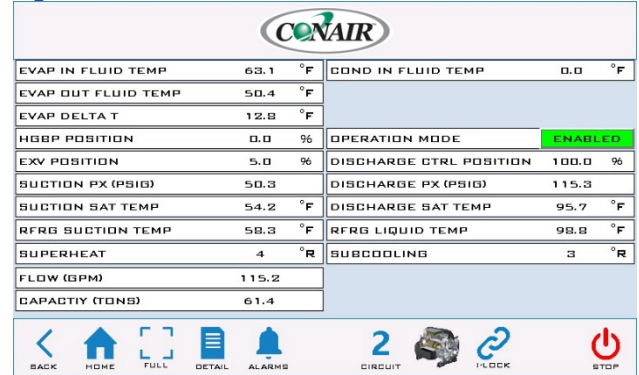

Figure 11 – Circuit Details Screen (Air-Cooled Chiller)



### Circuit Details Screen – Turbocor

Touching the Compressor button on the bottom of the Circuit Details Screen displays the Turbocor information.

Figure 12 – Turbocor Screen

CONAIR					
DEMAND %	100.0	CAVITY TEMP	-459°F	REQUESTED KW	0.0
IGV POSITION %	0.0	INVERTER TEMP	-459°F	ACTUAL KW	0.0
RUN HOURS	1	SCR TEMP	-459°F	3Ø MAINS (A)	0
ACTUAL RPM	700	BMCC TEMP	-459°F	3Ø MAINS (V)	0
DESIRED RPM	0	EVAP IN	63.1°F	DC BUS (V)	0
SURGE RPM	0	EVAP OUT	50.4°F	MOTOR (A)	0
CHOKE RPM	0	EVAP DELTA T	12.8°F	24VDC	0.0
PX RATIO	0			NO CRITICAL FAULTS	
PX RATIO CALC	-5			NO ALARMS	
PX RATIO ALARM SP	1.0			EXV %	5.0
CHILLER SETPOINT	45.0	SUCTION PX	50.3	HBB %	0.0
SUPERHEAT	4.0	DISCHARGE PX	115.3	DISCHARGE %	100.0

### Circuit Details Screen – Interlocks

Touching the I-LOCK button of the Circuit Details Screen (Figure 11) displays the Interlocks Screen shown in Figure 13.

Figure 13 – Interlocks

CONAIR			
DEMAND	YES	E-STOP	OK
RUNNING	YES	EVAP FLOW SWITCH	OK
ALLOWED	YES	MODBUS STATUS	OK
COMPRESSOR ONLINE	YES		

Touching the CRITICAL button opens the Critical Interlocks Screen (Figure 14). A critical interlock fault shuts down the entire system and must be resolved prior to a restart.

Figure 14 – Critical Interlocks

CONAIR	
E-STOP STATUS	OK
EVAP AVERAGING	OK
ENTERING FLUID TEMP	OK

### Menu 1 – Circuit Demand

#### Circuit Demand Screen

Figure 15 – Demand Circuit

CONAIR			
DEMAND HOLDBACK TIMER	600	AUTOMATIC MODE	YES
MINIMUM DEMAND PERCENT	15	CIRCUIT RUNNING	YES
KP	30	DEMAND HOLD	NO
TI	500	SLOW SPEED	NO
TD	0	ID	10000
		ED	10000
		PV	50.4
		SP	45.0
		DEMAND PERCENT	100.0 %

### Menu 1 – Logging

The HMI is constantly logging key registers internal to the HMI. In the event that the data and/or alarm logs require review, it is possible to export data to an external thumb drive. Data logging occurs every two seconds in a FIFO methodology for a total of 24 hours.

Figure 16 – Logging Screen

CONAIR	
START LOGGING	STOP LOGGING
EXPORT DATA LOG TO USB	EXPORT ALARM LOG TO USB
CLEAR LOG	

## Menu 1 – Trending

The trending screen (Figure 17) displays the setpoint temperature, process temperature, demand, expansion valve, and optional hot gas bypass valve (if present) registers for easy analysis of the system operation. Trending is always enabled and always running.

Figure 17 – Trending Screen

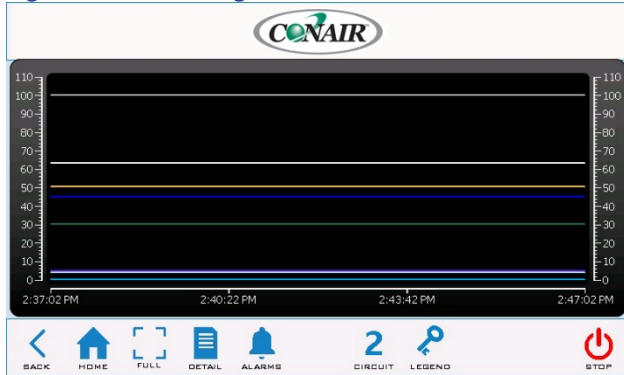

## Menu 1 – Inputs / Outputs

### Inputs / Outputs Screens

The Inputs/Outputs screens provide the status of all digital inputs, digital outputs, analog inputs, and outputs. When the PLC input LED is on the corresponding input or output is on. The inputs and outputs numbers are hex base numbering system. The following screens show a full complement of inputs and outputs. Note: Your screen may differ depending on machine type and options.

Figure 18 – Digital Inputs Screen

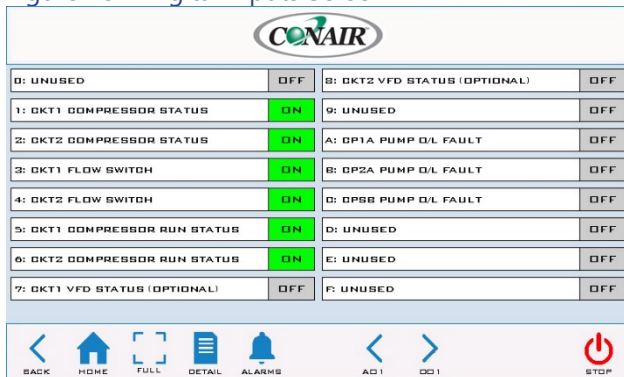

Figure 19 – Digital Outputs Screen

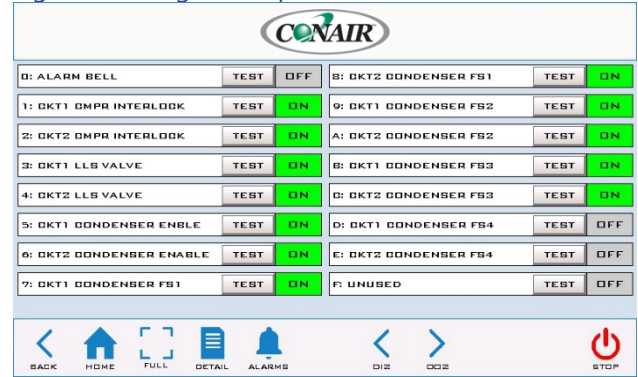

Figure 20 – Analog Outputs Screen

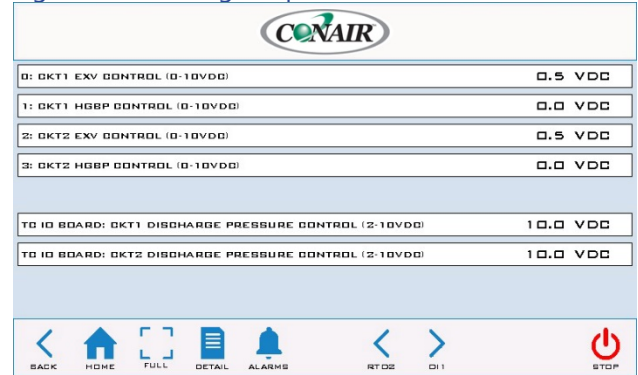
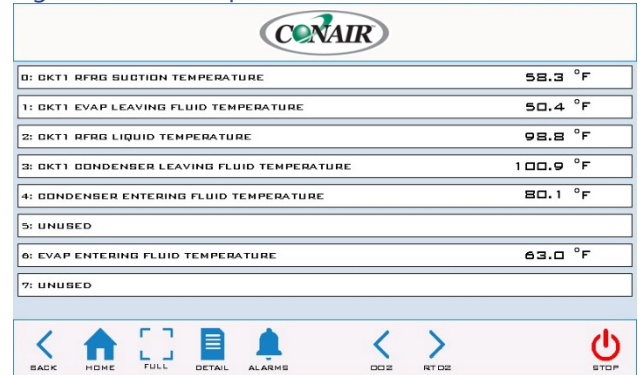

Figure 21 – RTD Inputs Screen



## Menu 1 – Hot Gas Bypass

### Hot Gas Bypass Setup Screen

Figure 22 – Hot Gas Bypass Screen

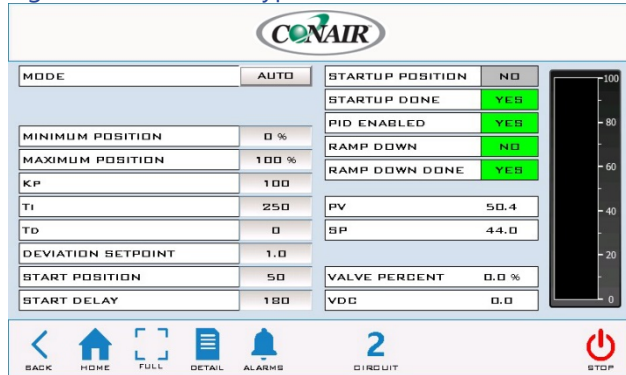

Table 8 – HGBP Setup Parameters

Menu Item	Description	Default Value
Mode	AUTO MODE: The valve will always respond relative to the demand PID regardless of how many compressors are running. MANUAL MODE: The manual mode value percent will be the output to the valve.	AUTO ON
Minimum Position	The minimum percent the valve will go to.	0%
Maximum Position	The maximum percent the valve will go to.	100%
Kp	Proportional PID value	100
Ti	Integral PID value	250
Td	Derivative PID value	0
Start Position	This sets the valve to a pre-start position for a given period.	50
Start Delay Selection	This is the delay time from compressor start-up to hold the valve at the start-up percent open position	180 seconds

## Menu 1 – Expansion Valve Setup

### EXV Control Setup Screen

Figure 23 – EXV Control Screen

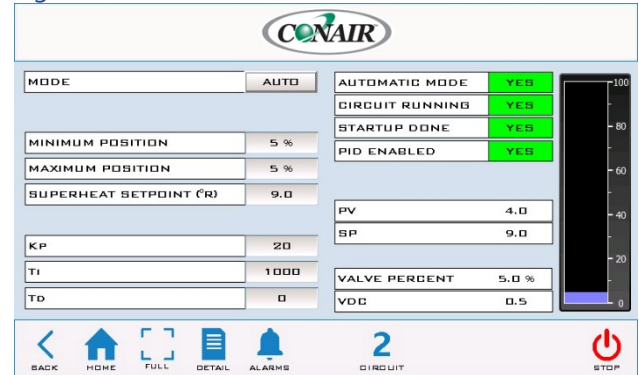

Table 9 – EXV Setup Parameters

Menu Item	Description	Default Value
Mode Control	In Auto Mode, the control system adjusts the valve to maintain discharge pressure. In manual mode, the system drives the valve to a fixed position and holds it there for service diagnostic purposes.	AUTO MODE
Minimum Position	The minimum percent the expansion valve will go to.	5%
Maximum Position	The maximum percent the expansion valve will go to.	100%
Superheat Setpoint	The valve meters the amount of refrigerant into the evaporator in the precise quantity in order to maintain superheat. The difference between the saturated suction temperature and the suction line temperature is the superheat. The superheat is factory set for 10°F and should never exceed 15°F or go below 4°F. Only a trained refrigeration service technician should adjust this valve.	9.0
Kp	Proportional PID value	20
Ti	Integral PID value	1000
Td	Derivative PID value	0
Td	Derivative PID value	0

## Menu 1 – Discharge Control Setup

### Discharge Control Setup Screen

An electric condenser water-regulating valve is standard on chillers with a water-cooled condenser. The valve is a butterfly type valve with a modulating actuator and is located in the condenser water piping at the outlet of the condenser. The valve regulates the flow of cooling water through the condenser in order to maintain the discharge refrigerant pressure set point.

Figure 24 – Discharge Control Screen

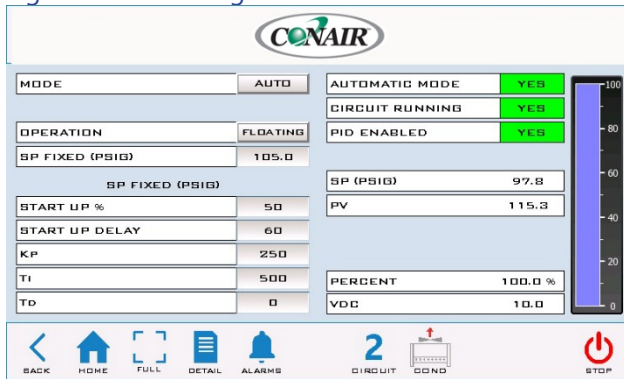

Figure 25 – Discharge Control Screen (TCR only)

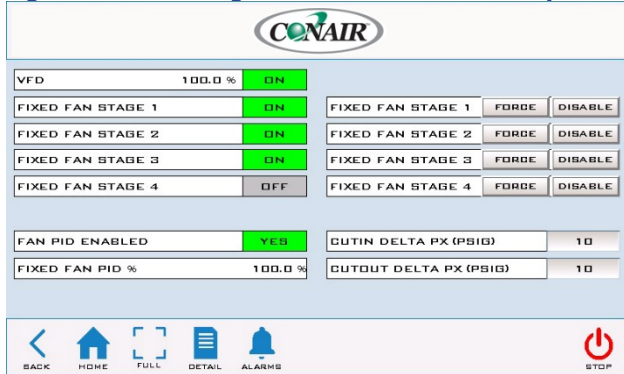

Table 10 – Discharge Setup Parameters

Menu Item	Description	Default Value
Mode	In Auto Mode, the valve adjusts to maintain optimum performance. In manual mode, it holds to the input valve.	Automatic
Manual Mode Value	This is only visible when the discharge pressure control is in manual mode. To place the discharge pressure control into manual mode, press the MODE button to display the manual percent output. Press the area next to the % sign and enter a value between 0 to 100% to change the analog output value. There is a short time delay before the analog output begins to change. This feature is for testing purposes.	N/A
Control Mode Floating or Fixed	This button switches between a preset entered discharge pressure set point (Fixed) and a calculated one (Floating). The calculated discharge pressure set point is determined based upon the saturated pressure value as a function of temperature. The default selection is Floating and seeks to obtain maximum efficiency. The Manual selection allows alteration of the discharge PX set point within the acceptable range.	Floating
Fixed Discharge Pressure SP	This is the fixed set point to control the discharge pressure.	105psig
Start Up %	This value equals the percentage of maximum voltage sent from the terminals of the Compressor Interface Module to the variable speed fan on compressor start-up. The analog output will hold at this position until the start delay timer has expired (Note: The operating range must be set to 0-10V (DEFAULT) via jumpers on the Compressor Interface module).	50%
Start Up Delay	This is the time in seconds that the output starting percent is held upon compressor start-up	60 sec.
Kp	Proportional Gain – Adjust for stable PID control.	250 (TCR) 75 (TCW)
Ti	Integral Gain – Adjust for stable PID control.	500 (TCR) 250 (TCW)
Td	Derivative PID value	0

## Menu 1 – Modbus Compressor(s)

### Compressor Modbus Screen

The controller communicates with the compressor via Modbus communications. This communication is critical for compressor operation.

Figure 26 – Circuit 1 Additional Detail

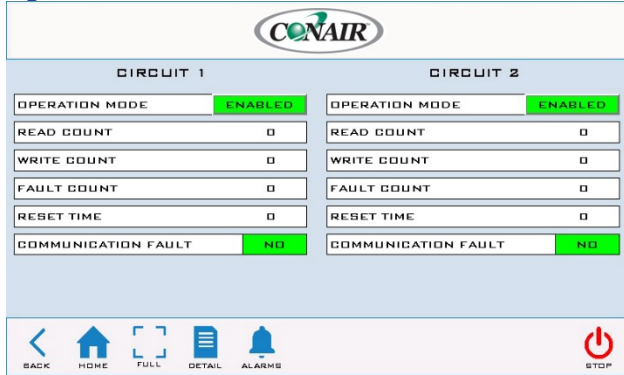

Table 11 – Modbus Setup

Menu Item	Description
Operation Mode	Touching the Circuit Enabled will toggle it between enabled (Green) and disabled (Yellow). If you choose to disable the circuit then disable it here. Modbus communication to the compressor will also stop once disabled.
Read Count	The number of successful read attempts from the Compressor.
Write Count	The number of successful writes to the Compressor.
Fault Count	The number of failed read or write attempts from/to the Compressor. An alarm occurs after five failed attempts.
Reset Time	If the compressor is enabled and there is a Modbus fault, the system will retry to establish communications every 60 seconds.
Communication Fault	If a Modbus error occurs, the FAULT indicator and alarm display. The fault will display just below the CIRCUIT label.

## Menu 1 – Flow / Capacity

### Flow/Capacity Screen

The graph displays trend data for the process fluid flow measured at the outlet of the evaporator on each chiller circuit. In addition, there is a display of an approximation of chiller cooling capacity calculated by the process fluid flow rate and temperature difference.

Figure 27 – Flow / Capacity Screen

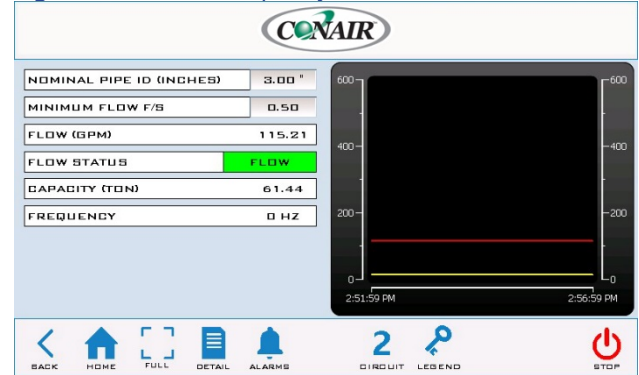

## Menu 1 – Pump Control

### Pump Control Screen

This screen displays pertinent pump status information for a system with the optional integral pump controls and provides the ability to change mode selection.

Figure 28 – Pump Control Screen

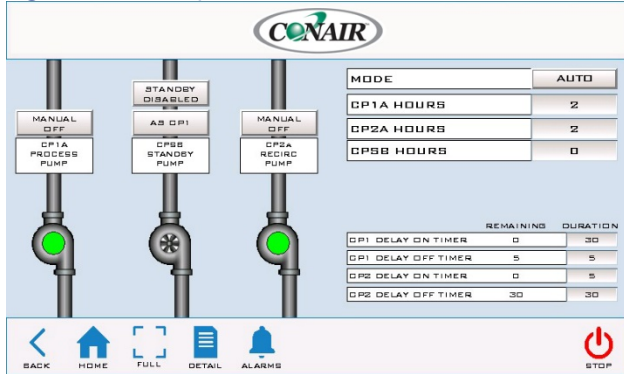

Table 12 – Pump Setup Parameters

Menu Item	Description	Default Value
Mode	AUTOMATIC: Allows for automatic timer enable of the pumps. MANUAL: Requires manual enable of the pumps.	AUTOMATIC
Recirc On Delay	Delay duration before the Recirculation Pump starts.	0 sec
Recirc Off Delay	Delay duration before stopping the Recirculation Pump after initiation of a system stop.	5 sec
Process On Delay	Delay duration before the Process Pump starts.	0 sec
Process Off Delay	Delay duration before stopping the Process Pump after initiation of a system stop.	30 sec

## Menu 1 – Staging

### Compressor Staging Setup Screen

Figure 29 – Compressor Staging Screen

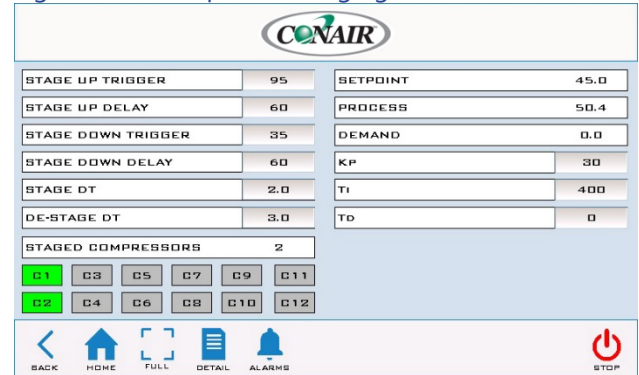

Table 13 – Compressor Staging Parameters

Menu Item	Description	Default Value
Stage Up Trigger	This parameter in conjunction with the Stage Up Delay determines at what percent the next compressor will stage.	95%
Stage Up Delay	Once the demand reaches the Stage Up Trigger, this value determines the time delay before staging the next compressor.	60 sec.
Stage Down Trigger	This parameter in conjunction with the Stage Down Delay determines when a compressor will de-stage.	35%
Stage Down Delay	Once the demand reaches the Stage Down Trigger, this value determines the time delay before de-staging a compressor.	60 sec.
Stage DT	This set point works in conjunction with the Chilled Water Set Point to limit short cycling. The first compressor will not stage until the Chilled Water Set Point + $\Delta T$ Stage Set Point is satisfied. Only applies if one compressor is running.	2°F
De-stage DT	This parameter de-stages a compressor when the Chilled Water Set Point less the $\Delta T$ De-stage Set Point is met. This only applies if one compressor is running.	3°F
Staged Compressors	This is the number of compressors that initially start when the system has a demand.	1

## Menu 1 – Stage Order

### Compressor Staging Setup Screen

Figure 30 – Compressor Stage Order Screen

UNIT	CIRCUIT	STAGE	HOURS
UNIT 1	CIRCUIT 1	1	1
UNIT 1	CIRCUIT 2	2	1
UNIT 2	CIRCUIT 1	0	65535
UNIT 2	CIRCUIT 2	0	65535
UNIT 3	CIRCUIT 1	0	65535
UNIT 3	CIRCUIT 2	0	65535
UNIT 4	CIRCUIT 1	0	65535
UNIT 4	CIRCUIT 2	0	65535
UNIT 5	CIRCUIT 1	0	65535
UNIT 5	CIRCUIT 2	0	65535
UNIT 6	CIRCUIT 1	0	65535
UNIT 6	CIRCUIT 2	0	65535

STAGE MODE: **AUTO**      STAGE ORDER STATUS: **GOOD**

MINUTES UNTIL AUTO-STAGE: 9995

Table 14 – Compressor Staging Local Parameters

Menu Item	Description	Default Value
Stage Mode	Automatic: calculates the stage order by the AUTO STAGE HOURS parameter Manual: Manually enter the stage order	AUTOMATIC
Trigger	Trigger will immediately recalculate the stage order instead of waiting for the automatic trigger to occur.	None
Minutes Until Auto stage	Minutes remaining until the stage calculation occurs	None

## Menu 2 – Overview

Figure 31 – Menu 2 Screen

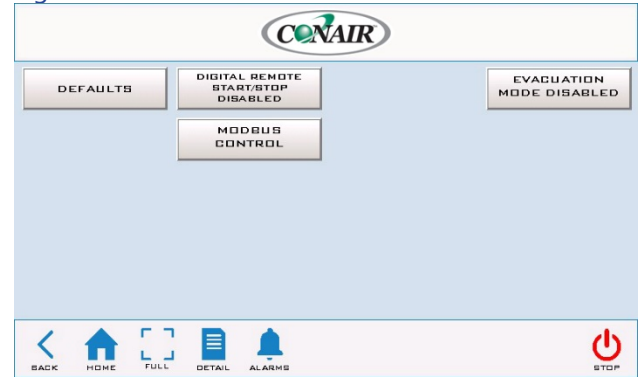

Table 15 – Menu 2 Functions

Function	Description	Screen Reference
Defaults	Provides the ability to restore the control system back to factory defaults in the case that an unknown setting occurred and the system now behaves unexpectedly.	Figure 32 Figure 33
Remote Mode	Touch this button to enable or disable external digital remote START/STOP	N/A
Modbus Control	Modbus RTU (Building Automation System) Setup Default Modbus Settings: Baud-19200, Data Length-8, Parity-Odd, Stop Bits-1	Figure 34
Evacuation Mode	Allow a full equalization of refrigerant pressure during a remote startup evacuation.	N/A

## Menu 2 – Defaults



**CAUTION:** The Defaults screen provides the ability to restore the control system back to factory defaults in the case that an unknown setting modification occurred and the system now behaves unexpectedly.

Touching “LOAD” on Figure 32 will restore all the system parameters to a factory stable state and indicate that the process has finished as shown in Figure 33.

Figure 32 – Restore Factory Settings

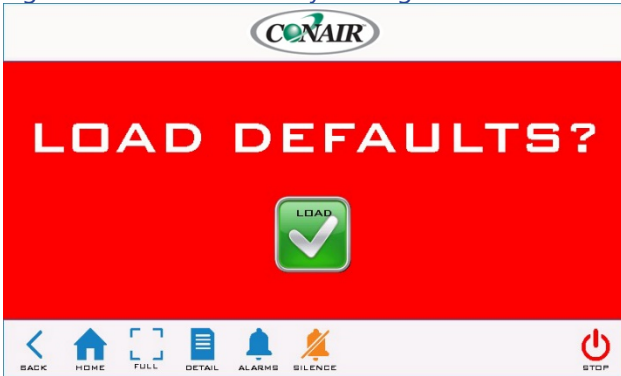
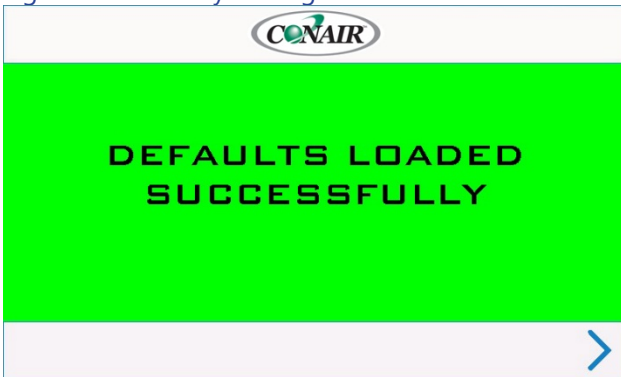

Figure 33 – Factory Settings Restored



## Menu 2 – Remote Mode

The Remote Mode toggle indicates if the chiller is set to use a remote contact closure for remote start/stop. When active, the Remote Mode toggle will indicate Remote Start/Stop Enabled and when not active it will indicate Remote Start/Stop Disabled.

## Menu 2 – Modbus/BAS

This Modbus BAS Setup Screen (Figure 34) can enable or disable the Modbus RTU capability. Default Modbus Settings: Baud-57600, Data Length-8, Parity-Odd, Stop Bits-1.

Figure 34 – Modbus Setup Screen

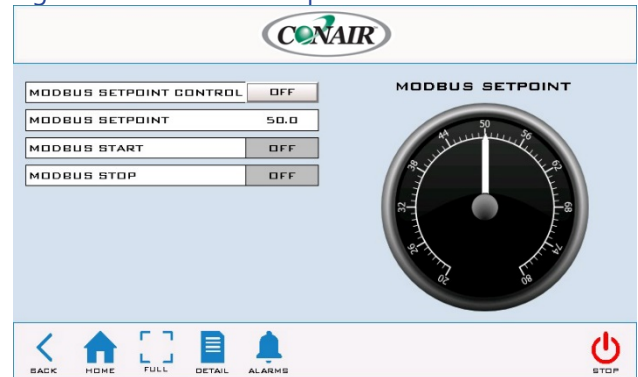

## Start-Up

Every unit is factory set to deliver chilled water in accordance with the standard operating specifications for that particular chiller. Due to variables involved with different applications and different installations, minor adjustments may be required during the initial start-up to ensure proper operation. Use a qualified refrigeration technician to perform the start-up procedure in sequence. The following serves as a checklist for the initial start-up and for subsequent start-ups if the chiller is out of service for a prolonged time.



**WARNING:** This equipment contains hazardous voltages that can cause severe injury or death.



**WARNING:** This equipment contains refrigerant under pressure. Accidental release of refrigerant under pressure can cause personal injury and or property damage.



**WARNING:** This equipment may contain fan blades or other sharp edges. Make sure all fan guards and other protective shields are securely in place.



**WARNING:** The exposed surfaces of motors, refrigerant piping, and other fluid circuit components can be very hot and can cause burns if touched with unprotected hands.



**CAUTION:** Disconnect and lock out incoming power before installing, servicing, or maintaining the equipment. Connecting power to the main terminal block energizes the entire electric circuitry of the unit. Electric power at the main disconnect should be shut off before opening access panels for repair or maintenance.



**CAUTION:** Wear eye protection when installing, maintaining, or repairing the equipment to protect against any sparks, debris, or fluid leaks.



**CAUTION:** Wear protective gloves when installing, maintaining, or repairing the equipment to protect against any sparks, debris, or fluid leaks.



**CAUTION:** Wire the unit ground in compliance with local and national codes.

## Step 1 – Connect Main Power

Connect main power properly ensuring it matches the voltage shown on the nameplate of the unit. Check the electrical phase sequence prior to start-up. Operation of the compressor with incorrect electrical phase sequencing will cause damage to the compressors. Check the phasing prior to applying power. The proper sequence is "ABC." If the phasing is incorrect, open the main power disconnect and switch two line leads on the main power terminal blocks (or the unit mounted disconnect). All electrical components are in-phase at the factory. Do not interchange any load leads that are from the unit contactors or the motor terminals. After making proper power connection and grounding, turn the main power on.

## Step 2 – Fill Coolant Circuit

Check to make sure all process chilled-water piping connections are secure. Open the chiller cabinet and fill the coolant reservoir with the proper water or water/glycol solution following the guidelines shown below. When using a glycol solution only use glycol with a corrosion inhibitor.

### System Fill Water Chemistry Requirements

The properties of water make it ideal for heat transfer applications. It is safe, non-flammable, non-poisonous, easy to handle, widely available, and inexpensive in most industrialized areas.

When using water as a heat transfer fluid it is important to keep it within certain chemistry limits to avoid unwanted side effects. Water is a "universal solvent" because it can dissolve many solid substances and absorb gases. As a result, water can cause the corrosion of metals used in a cooling system. Often water is in an open system (exposed to air) and when the water evaporates, the dissolved minerals remain in the process fluid. When the concentration exceeds the solubility of some minerals, scale forms. The life giving properties of water can also encourage biological growth that can foul heat transfer surfaces.

To avoid the unwanted side effects associated with water cooling, proper chemical treatment and preventive maintenance is required for continuous plant productivity.

*Unwanted Side Effects of Improper Water Quality*

- Corrosion
- Scale
- Fouling
- Biological Contamination

*Cooling Water Chemistry Properties*

- Electrical Conductivity
- pH
- Alkalinity
- Total Hardness
- Dissolved gases

Chillers at their simplest have two main heat exchangers: one that absorbs the heat from the process (evaporator) and one that removes the heat from the chiller (condenser). All our chillers use stainless steel brazed plate evaporators. Our air-cooled chillers use air to remove heat from the chiller; however, our water-cooled chillers use either a tube-in-tube or shell-in-tube condenser which has copper refrigerant tubes and a steel shell. These, as are all heat exchangers, are susceptible to fouling of heat transfer surfaces due to scale or debris. Fouling of these surfaces reduces the heat-transfer surface area while increasing the fluid velocities and pressure drop through the heat exchanger. All of these effects reduce the heat transfer and affect the efficiency of the chiller.

The complex nature of water chemistry requires a specialist to evaluate and implement appropriate sensing, measurement and treatment needed for satisfactory performance and life. The recommendations of the specialist may include filtration, monitoring, treatment and control devices. With the ever-changing regulations on water usage and treatment chemicals, the information is usually up-to-date when a specialist in the industry is involved. Table 16 shows the list of water characteristics and quality limitations.

Table 16 – Fill Water Chemistry Requirements

Water Characteristic	Quality Limitation
Alkalinity (HCO <sub>3</sub> <sup>-</sup> )	70-300 ppm
Aluminum (Al)	Less than 0.2 ppm
Ammonium (NH <sub>3</sub> )	Less than 2 ppm
Chlorides (Cl <sup>-</sup> )	Less than 300 ppm
Electrical Conductivity	10-500µS/cm
Free (aggressive) Carbon Dioxide (CO <sub>2</sub> )†	Less than 5 ppm
Free Chlorine(Cl <sub>2</sub> )	Less than 1 PPM
HCO <sub>3</sub> <sup>-</sup> /SO <sub>4</sub> <sup>2-</sup>	Greater than 1.0
Hydrogen Sulfide (H <sub>2</sub> S)	Less than 0.05 ppm
Iron (Fe)	Less than 0.2 ppm
Manganese (Mn)	Less than 0.1 ppm
Nitrate (NO <sub>3</sub> )	Less than 100 ppm
pH	7.5-9.0
Sulfate (SO <sub>4</sub> <sup>2-</sup> )	Less than 70 ppm
Total Hardness (dH)k	4.0-8.5

† Dissolved carbon dioxide calculation is from the pH and total alkalinity values shown below or measured on the site using a test kit. Dissolved Carbon Dioxide, PPM = TA x 2<sup>[(6.3-pH)/0.3]</sup> where TA = Total Alkalinity, PPM as CaCO<sub>3</sub>

Table 17 - Recommended Glycol Solutions

Chilled Water Temperature	Percent Glycol By Volume
50°F (10°C)	Not required
45°F (7.2°C)	5 %
40°F (4.4°C)	10 %
35°F (1.7°C)	15 %
30°F (-1.1°C)	20 %
25°F (-3.9°C)	25 %
20°F (-6.7°C)	30 %



*CAUTION: When your application requires the use of glycol, use industrial grade glycol specifically designed for heat transfer systems and equipment. Never use glycol designed for automotive applications. Automotive glycols typically have additives engineered to benefit the materials and conditions found in an automotive engine; however, these additives can gel and foul heat exchange surfaces and result in loss of performance or even failure of the chiller. In addition, these additives can react with the materials of the pump shaft seals resulting in leaks or premature pump failures.*



*WARNING: Ethylene Glycol is flammable at higher temperatures in a vapor state. Carefully handle this material and keep away from open flames or other possible ignition sources.*

### Step 3 - Check Condenser

There are two possible types of condensers present in the chiller: water-cooled and remote air-cooled. It is important to verify the chiller will have adequate condenser cooling for proper chiller operation.

#### Water-Cooled Condenser Check

Check the condenser water lines to make sure all connections are secure. Make sure sufficient condenser water flow and pressure are available, the condenser water supply is on, and all shut-off valves are open. The electronic water regulating valves ship in the closed position and opens after enabling the circuit.

#### Remote Air-Cooled Condenser Check

Check the refrigerant lines to make sure all connections are secure and the refrigeration is as described in the installation section of this manual. Check the remote condenser main power and control wiring to ensure all connections are secure.

### Step 4 – Check Refrigerant Valves

During shipment or installation it is possible valves were closed. Verify that all refrigerant valves are open.

### Step 5 – Check Low Temperature Alarm

Make sure the Low Temperature Alarm Set Point is proper for the operating conditions of the chiller. The Low Temperature Alarm setting is in a password-protected menu of the chiller controller. Refer to the control section of this manual for instructions on how to access this menu. Set the Low Temperature Alarm 10°F below the minimum chilled water temperature setting that the chiller will be operating. Also, ensure the process coolant has sufficient freeze protection (glycol) to handle at least 5°F below the Low Temperature Alarm setting. All chillers ship with the Low Temperature Alarm set at 35°F. This protects against a possible freeze-up if no glycol is present. Once the proper glycol solution is present, adjust the Low Temperature Alarm to the appropriate setting.



**CAUTION:** The manufacturer's warranty does not cover the evaporator from freezing. It is vital that the Freezestat is set properly.

### Step 6 – Turn On Control Power

Turn on the control power by turning the control power switch to "On." The panel should be on. Due to extreme ambient temperatures during shipment and installation, you may encounter a High Refrigerant Pressure alarm when you turn on the control power. If this is the case, reset the alarm and do not proceed until no further alarm conditions are present.

### Step 7 – Establish Coolant Flow

Establish flow through the chiller.

*Note: The compressor will not start as long as the flow switch is open. The compressors only operate if there is a positive flow through the evaporator.*

Set water flow using a discharge throttling valve or flow control valve (by others). The valve should be the same size as the To Process connection of the chiller. Standard chillers operate with approximately 2.4 gpm/ton of nominal capacity. A significant increase in flow beyond this in a standard chiller may result in excessive pressure loss and negatively impact chiller efficiency and in extreme cases may cause premature wear or damage of internal components.

### Step 8 – Initial Unit Operation

Enter the desired leaving fluid temperature on the chiller HMI. Unless otherwise specified, the chiller is factory set to deliver coolant at 50°F. Adjust to the desired operating temperature. The chiller should now be controlling to the selected temperature. Please note that if there is insufficient load the compressor may cycle on and off causing swings in temperature.



**WARNING:** Under no circumstance, deactivate the High Refrigerant Pressure or the Low Compressor Pressure switches. Failure to heed this warning can cause serious compressor damage, severe personal injury, or death.

Operate the system for approximately 30 minutes. Check the liquid line sight glass. The refrigerant flow past the sight glass should be clear. Bubbles in the refrigerant indicate either low refrigerant charge or excessive pressure drop in the liquid line. An indication of a shortage of refrigerant is if operating pressures are low and sub-cooling is low. Normal sub-cooling ranges from 10°F to 20°F. If the sub-

cooling is not within this range, check the superheat and adjust if required. The superheat should be approximately 10°F. If the operating pressures, sight glass, superheat, and subcooling readings indicate a refrigerant shortage, charge refrigerant as required. With the unit running, add refrigerant using industry best practices until operating conditions become normal.



*CAUTION: A clear sight glass alone does not mean that the system is properly charged. Also, check system superheat, subcooling, and unit operating pressures. If both suction and discharge pressures are low but subcooling is normal, a problem other than refrigerant shortage exists. Do not add refrigerant, as this may result in overcharging the circuit.*

After achieving proper flow and temperature, press the Stop button. The unit is now ready for service.

## Preventive Maintenance

---

Once your chiller is in service, follow the maintenance procedures as closely as possible. Specific site conditions may require repeating certain tasks more frequently. The importance of a properly established preventive maintenance program cannot be overemphasized. Taking the time to follow these simple procedures will result in substantially reduced downtime, reduced repair costs, and an extended useful lifetime for the chiller. Any monetary costs of implementing these procedures will usually more than pay for itself.

### Once a Week

1. Check to make sure that the To Process temperature is reasonably close to the Set Point temperature. If the temperature stays more than 5°F away from the set point, there may be a problem with the chiller. If this is the case, refer to the Troubleshooting Chart or contact our Customer Service Department.
2. Check the suction and discharge refrigerant pressure at the compressor.
3. Check each refrigerant sight glass for air bubbles or moisture indication. Bubbles in the refrigerant indicate either low refrigerant charge or excessive pressure drop in the liquid line. If the sight glass indicates that there is a refrigeration

problem, have the unit serviced as soon as possible.

4. Units are equipped with a Y-strainer between the return connection and the evaporator inlet. Open the blow-down valve attached to the strainer to flush the screen free of debris.

### Once a Month

Repeat items 1 through 4 and continue with the following.

5. Shut off the power disconnect. Check the condition of electrical connections at all controls. Check for loose or frayed wires.
6. Check the main power supply to ensure it is acceptable, connected properly, and the unit has a proper ground (see Installation section of this manual for details).
7. Check the amp draws to each leg of the compressor(s) to confirm that it is drawing the proper current.
8. Check the system superheat and sub-cooling. The normal superheat is approximately 10°F and should not be more than 15°F. The normal sub-cooling range is from 10°F to 20°F.
9. Units are equipped with a Y-strainer between the return connection and the evaporator inlet. Remove the strainer basket and clean if necessary. This may be required more often if contaminants can easily get into the process water.
10. Check the flow sensor tip visually for signs of build-up and clean with a soft cloth. If there is some suborn calcium build-up that is not easily removed with a soft cloth use household vinegar as a cleaning agent to remove the deposit.

### Once Every 6 Months

Repeat items 1 through 10 and continue with the following.

11. Check for visible mechanical damage to the compressor.
12. Check for excessive vibration from other rotating equipment.

13. Check for signs of hot spot/discoloration on power cables.
14. Check the DC bus voltage.
15. Check all communication cables are secure and tight.
16. Check all electrical modules are secure.
17. Check system refrigerant charge and verify the system is still full charged.

### Once a Year

Repeat items 1 through 17 listed and continue with the following.

18. (TCW Models) Check the condition of the condenser water for algae and scale. If contamination is present, rod out the tubes and back flush condensers before reconnecting pipes.
19. (TCR Models) Check the condition of the air coils of the remote condensers for dirt and debris. If the coils are dirty or clogged, use a compressed air source to blow the contaminants out of the air coil.
20. Check operation of all system safety devices and interlocks.
21. Check physical condition of all exposed circuit boards for dust build-up and clean if necessary.
22. Check calibration of temperature/pressure sensors.
23. Check operation of IGV assembly.

### Once Every 5 years

Repeat items 1 through 23 and continue with the following.

24. Replace capacitor set

## Maintenance

---

### Cleaning the Operator Interface

Use of abrasive cleaners or solvents may damage the window. Do not scrub or use brushes. To clean the display window:

1. Disconnect power from the terminal at the power source.
2. Using a clean sponge or a soft cloth, clean the display with a mild soap or detergent. If paint or grease splash is present, remove before drying by rubbing lightly with isopropyl alcohol. Afterward, provide a final wash using a mild soap or detergent solution. Rinse with clean water.
3. Dry the display with a chamois or moist cellulose sponge to avoid water spots.

## Troubleshooting

Symptom	Possible Cause	Action Required
Low suction pressure	Low water flow	Check fluid flow is within design, clean Y-strainer
	Chilled water temperature too low	Check set point
	Faulty pressure sensor	Check sensor
	Low refrigerant charge	Check sub-cooling and discharge temperatures
	Restriction in refrigerant piping	Check electronic expansion valve and filter drier
	Inlet guide vane (IGV) stuck open	Check position and operation
	Fouled Evaporator	Back flush and chemically clean
High discharge pressure	Condenser water temperature too high (TCW Models only)	Check cooling tower system set point
	Condenser coils dirty or condenser fan failure (TCR Models only)	Check condenser
	Low condenser water flow (TCW Models only)	Check condenser water flow is 3 gpm per ton per circuit
	Fouled condenser water tubes (TCW Models only)	Check and clean condenser tubes
	Faulty pressure sensor	Check pressure sensor
	Non-condensable in system	Dehydrate system
	System overcharged	Adjust refrigerant charge
	Discharge valve closed	Check valve position
Restrictions in piping	Check piping for excessive pressure drops	
High evaporator pressure	Chilled water temperature too high	Check temperature sensor. Check for excessive fluid flow.
	Faulty pressure sensor	Check pressure transducer
	Inlet guide vane (IGV) failure (closed)	Check position and operation
	Electronic expansion valve failed open	Check position and operation
Low water temperature cut-out	Insufficient refrigerant charge	Check refrigerant charge
	Faulty sensor	Check sensor
	Water temperatures too low	Check set points
	Low water flow	Check water flow, check Y-strainer, clean as necessary
Compressor does not power up	No/Low DC Bus voltage – capacitor failure	Check DC bus
	Phase failure	Check phases of line power supply
	No 250 VDC Bus – high voltage DC-DC converter fault	Check converter
	No 250 VDC Bus – Bearing PWM amplifier	Check PWM module and backplane
	No 250 VDC Bus – low voltage DC-DC converter fault	Check PWM module and backplane
	DC Bus midpoint imbalance – faulty capacitor	Replace capacitor
	DC Bus midpoint imbalance - faulty bleed resistor	Replace bleed resistor
DC Bus midpoint imbalance – faulty high voltage DC-DC converter	Replace high voltage DC-DC converter	
No motor drive	IGBT inverter fault	Check DC Bus
	IGBT inverter interface cable fault	Check cable
	Bearing/motor controller fault	Replace bearing/motor controller
	Faulty stator	Replace stator
	Demagnetized shaft	Replace shaft
Bearing will not calibrate or levitate	Shaft position sensor fault	Check/replace sensor
	Faulty bearing wiring	Check/repair wiring
	Faulty bearing PWM amplifier	Replace bearing PWM amplifier
No compressor controller connection	Faulty bearing/motor controller	Replace bearing/motor controller
	Faulty compressor controller	Replace compressor controller
	External wiring fault	Check/repair wiring
	Interface converter fault	Check/repair interface converter
Sensor fault – faulty wiring connector	Interface converter fault	Check/repair interface converter
	Sensor fault – faulty wiring connector	Check/replace wiring connector

## Troubleshooting (continued)

Symptom	Possible Cause	Action Required
Drive temperature too high	No motor cooling	Check motor cooling solenoid valve
	Insufficient sub-cooling	Check refrigerant charge
	Faulty temperature sensor	Check sensor
Winding temperature too high	Faulty power bolt	Check power bolt continuity
Compressor does not start	No cooling demand signal	Check temperature set points
	Faulty chilled water temperature sensors	Check chilled water temperature sensors
	No main power	Check power at terminal block
	Low water flow	Check water flow

## Drawings

---

We have prepared a customer set of drawings for your unit and placed them inside the control panel prior to shipment. Please refer to these drawings when troubleshooting, servicing, and installing the units. If you cannot find these drawings or wish to have additional copies sent, please contact our Customer Service Department and reference the serial number of your unit.

## We're Here to Help

Conair has made the largest investment in customer support in the plastics industry. Our service experts are available to help with any problem you might have installing and operating your equipment. Your Conair sales representative also can help analyze the nature of your problem, assuring that it did not result from misapplication or improper use.

## How to Contact Customer Service

To contact Customer Service personnel, call:



**NOTE:** Normal operating hours are 8:00 am - 5:00 pm (EST). After hours emergency service is available at the same phone number.

From outside the United States, call: 814-437-6861

You can commission Conair service personnel to provide on-site service by contacting the Customer Service Department. Standard rates include an on-site hourly rate, with a one-day minimum plus expenses.

## Before You Call...

**If you do have a problem, please complete the following checklist before calling Conair:**

- Make sure you have all model, control type from the serial tag, and parts list numbers for your particular equipment. Service personnel will need this information to assist you.
- Make sure power is supplied to the equipment.
- Make sure that all connectors and wires within and between control systems and related components have been installed correctly.
- Check the troubleshooting guide of this manual for a solution.
- Thoroughly examine the instruction manual(s) for associated equipment, especially controls. Each manual may have its own troubleshooting guide to help you.
- Check that the equipment has been operated as described in this manual.
- Check accompanying schematic drawings for information on special considerations.

## Equipment Guarantee

Conair guarantees the machinery and equipment on this order, for a period as defined in the quotation from date of shipment, against defects in material and workmanship under the normal use and service for which it was recommended (except for parts that are typically replaced after normal usage, such as filters, liner plates, etc.). Conair's guarantee is limited to replacing, at our option, the part or parts determined by us to be defective after examination. The customer assumes the cost of transportation of the part or parts to and from the factory.

## Performance Warranty

Conair warrants that this equipment will perform at or above the ratings stated in specific quotations covering the equipment or as detailed in engineering specifications, provided the equipment is applied, installed, operated and maintained in the recommended manner as outlined in our quotation or specifications.

Should performance not meet warranted levels, Conair at its discretion will exercise one of the following options:

- Inspect the equipment and perform alterations or adjustments to satisfy performance claims. (Charges for such inspections and corrections will be waived unless failure to meet warranty is due to misapplication, improper installation, poor maintenance practices or improper operation.)
- Replace the original equipment with other Conair equipment that will meet original performance claims at no extra cost to the customer.
- Refund the invoiced cost to the customer. Credit is subject to prior notice by the customer at which time a Return Goods Authorization Number (RGA) will be issued by Conair's Service Department. Returned equipment must be well crated and in proper operating condition, including all parts. Returns must be prepaid.

Purchaser must notify Conair in writing of any claim and provide a customer receipt and other evidence that a claim is being made.

## Warranty Limitations

Except for the Equipment Guarantee and Performance Warranty stated above, Conair disclaims all other warranties with respect to the equipment, express or implied, arising by operation of law, course of dealing, usage of trade or otherwise, including but not limited to the implied warranties of merchantability and fitness for a particular purpose.