

Compu-Dry

Dehumidifying Dryer
(Model CD-60)

User Guide

CONAIR

FRANKLIN

Part of the Conair Group

Route 8 North
Franklin, PA 16323
814-437-6861
Fax: 814-432-6227
Service: 800-888-9046
Parts: 800-458-1960

UGD005/1095



CD-60 DEHUMIDIFYING DRYER INSTRUCTIONS

EQUIPMENT DESCRIPTION

Conair Dehumidifying Dryers provide hot, low dewpoint air, circulated in a closed system, for fast moisture pick-up from hygroscopic plastic materials.

Drying air is passed through cartridges containing a molecular sieve desiccant where moisture is deposited. The dry air is then heated to a pre-set temperature so that air entering the drying hopper is always hot and "thirsty". Moisture picked up from the plastic material passes through a return hose from the drying hopper and once again passes through the molecular sieve desiccant.

Regeneration is accomplished by passing room air, heated to 425°F., through the desiccant and purging the moisture out of the system.

The Desiccant Assembly - See Figure 1

The "hollow core" desiccant cartridge design efficiently exposes the molecular sieve desiccant to moist air returning from the drying hopper. Water molecules in the return air are trapped in the desiccant, while low dewpoint air leaves the cartridge and enters the dryer's air heater compartment. Flowing over the heating elements, the dry air is brought back up to the selected temperature and re-enters the bottom of the drying hopper. There the heated, "thirsty" air again picks up moisture from the plastic pellets.

Before a desiccant cartridge can become completely saturated with trapped moisture, it switches "off-stream" to a high-heat regeneration condition, and is prepared for its next cycle through the process air stream. The core-type design and compact size enables the cartridge to regenerate quickly, using less power.

The dryers have been designed with a timed cycle capable of handling the worst conditions.

The desiccant has an almost unlimited life, but should it ever need replacement due to accidental contamination, cartridges may be easily replaced in less than 15 minutes. (See "Maintenance")

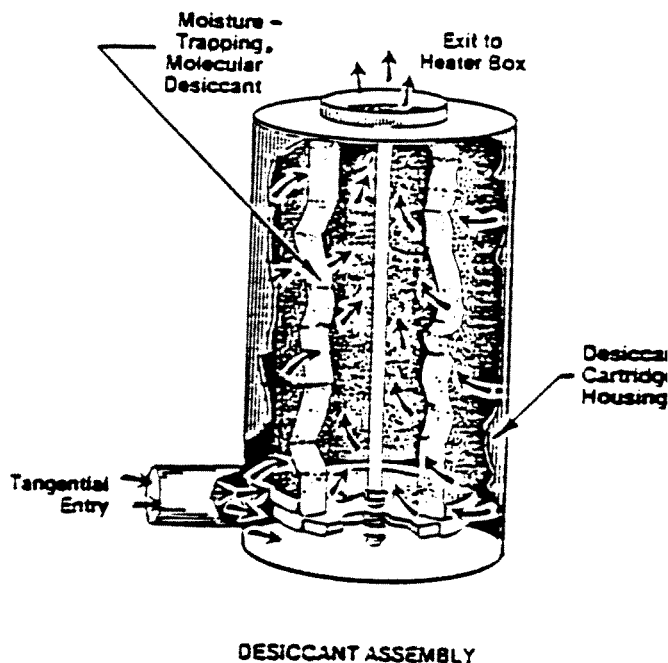
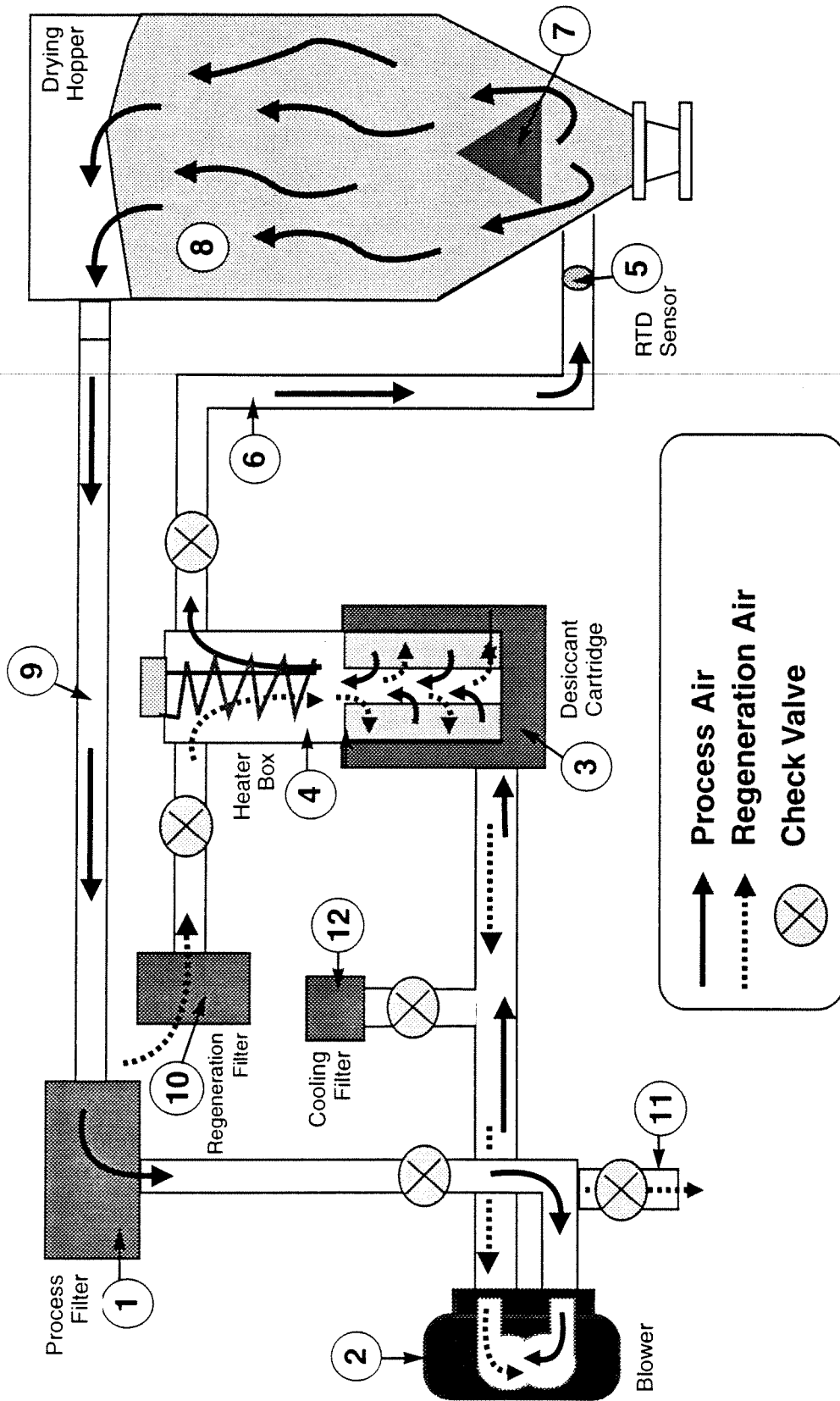

Figure 1

CD-60 DEHUMIDIFYING DRYER



Typical Air Flow Pattern

Figure 2

OPERATIONAL SEQUENCE

Drying Circuit

Return air is pulled through the process filter (1) by the process blower (2) and delivered into the desiccant cartridge (3), where it is thoroughly dehumidified. Then it passes into the process heater (4), where it is heated to the temperature selected by the machine operator on the control panel. The microprocessor control (5) assures heating to the proper temperature at the inlet of the hopper.

The process flexible hose (6) conducts the air into the drying hopper to the deflector cone (7), which distributes the flow evenly through the pellets (8), heats them and removes their moisture content. The moisture bearing air is then drawn into the flexible return hose (9), and the entire cycle is repeated.

Process Temperature

The process temperature is monitored and controlled at the inlet of the hopper. If a thermometer is used, it will be noted that during the regeneration/cooling cycle the process temperature will be reduced. This has no effect on the drying process. The temperature will come back up to process temperature once the dryer switches to the process cycle.

Regeneration Circuit

As the desiccant approaches saturation, the dryer switches from process cycle to regeneration cycle to purge the desiccant. At this time the blower will reverse rotation, temporarily shutting off air flow to the drying hopper.

The blower (2) draws air through a filter (10) and over the heater element (4) where it is brought to a very high temperature. The heated air flows through the "wet" cartridge (3) and purges it of moisture. The moist air is then blown through the exhaust (11) and out of the system. (For summer operation, or operation in air conditioned rooms, the exhaust air may be vented outdoors. However, care should be taken that the vent is large enough and does not restrict air flow).

Cooling Circuit

Immediately following regeneration, the fresh cartridge must be cooled before switching to the process cycle. This is accomplished by de-energizing the heaters and continuing to run the blower passing cool air through the desiccant.

VERY IMPORTANT: The air filters assure that only clean air flows through the drying circuit. Fines carried in the return air stream may eventually clog the filter, which can decrease efficiency. Check filters frequently and clean as necessary (See "Maintenance").

Timing Cycle

The dryer starts out with a 15-minute process cycle. This allows the operator to check air flow and process temperature settings. It then follows its standard 72-minute cycle. As follows:

1. Regeneration Cycle 6 Min.
2. Cooling Cycle 11 Min.
3. Process Cycle 55 Min.

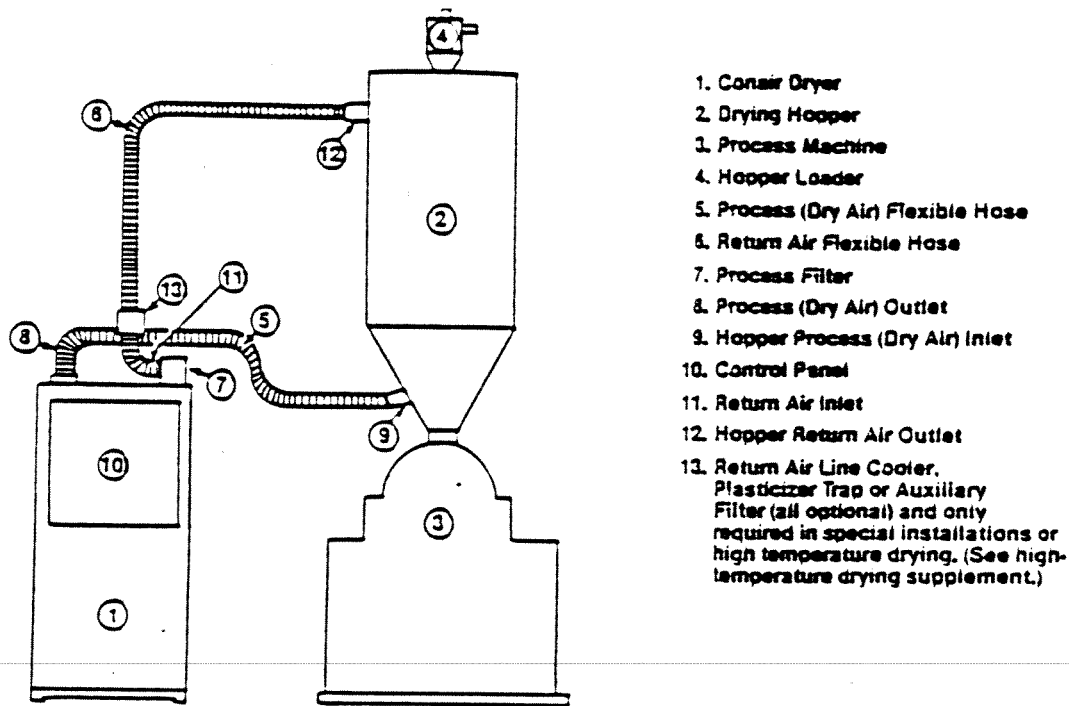

1. Conair Dryer
2. Drying Hopper
3. Process Machine
4. Hopper Loader
5. Process (Dry Air) Flexible Hose
6. Return Air Flexible Hose
7. Process Filter
8. Process (Dry Air) Outlet
9. Hopper Process (Dry Air) Inlet
10. Control Panel
11. Return Air Inlet
12. Hopper Return Air Outlet
13. Return Air Line Cooler, Plasticizer Trap or Auxiliary Filter (all optional) and only required in special installations or high temperature drying. (See high-temperature drying supplement.)

TYPICAL DRYER INSTALLATION

FIGURE 3

INSTALLATION

Dryer

The dryer should be located as close to the hopper as possible (no more than 10 ft. away) to reduce heat loss and energy consumption. The front of the control panel and the process filter should be easily accessible.

Clamp the process air flexible hose (5) to the dry air inlet at the bottom of the drying hopper (10).

Install the return air flexible hose (6) between the return air outlet on top of the drying hopper (13) and the return air inlet on the dryer (12).

Do not allow either of the flexible hoses to crimp or kink. If the hoses are too long, cut them to fit. Also, it is advisable to support long sections of hose where possible by tying to overhead structural members.

Electrical Information

The appropriate wiring diagram for your model of dryer is included in the back cover of this manual. It provides complete details on wiring and an electrical parts list.

VERY IMPORTANT: Make sure your dryer is connected to the correct voltage. Verify voltage by checking the nameplate on side of control box. All are prewired at the factory for service on **ONE VOLTAGE ONLY!**

DO NOT ATTEMPT TO ALTER VOLTAGE CONNECTIONS!

Prior to installing the drying hopper, an adapter plate may be required to be fitted to the throat of the process machine. (This plate may have been provided with the hopper if ordered that way.) Figure 4 shows the relative dimensions of the plate. If you cannot fabricate the adapter plate yourself, or have it done locally, send Conair a template of the throat and we will make the adapter plate. (price on request)

Standard Hopper Mounting Plate Dimensions
(Adapter must be provided to fit your machine)

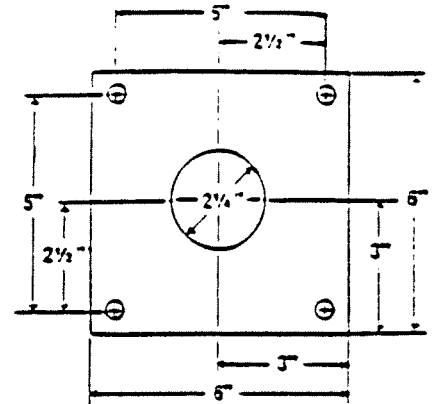
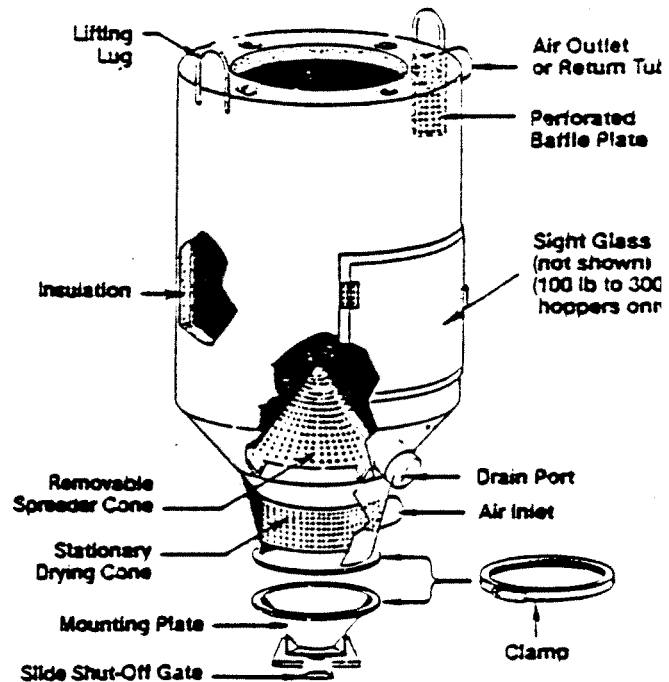

FIGURE 4

Drying Hopper

NOTE: Before installing hopper, check inside carefully for parts which may have been placed inside for shipping. Check also for air inlet and outlet obstructions. Inspect screen cone, and clean hopper thoroughly to remove rust prohibitor and any dirt which may have accumulated during shipping.

1. Bolt adapter plate to throat of molding machine.
2. Bolt hopper to adapter plate.
3. Attach vacuum loader to top of hopper, using clamping lugs provided. It is not necessary to drill holes in the top of the hopper. If loader flange does not rest flat on top of hopper, provide gasketing to prevent air loss.



DRYING HOPPER

FIGURE 5

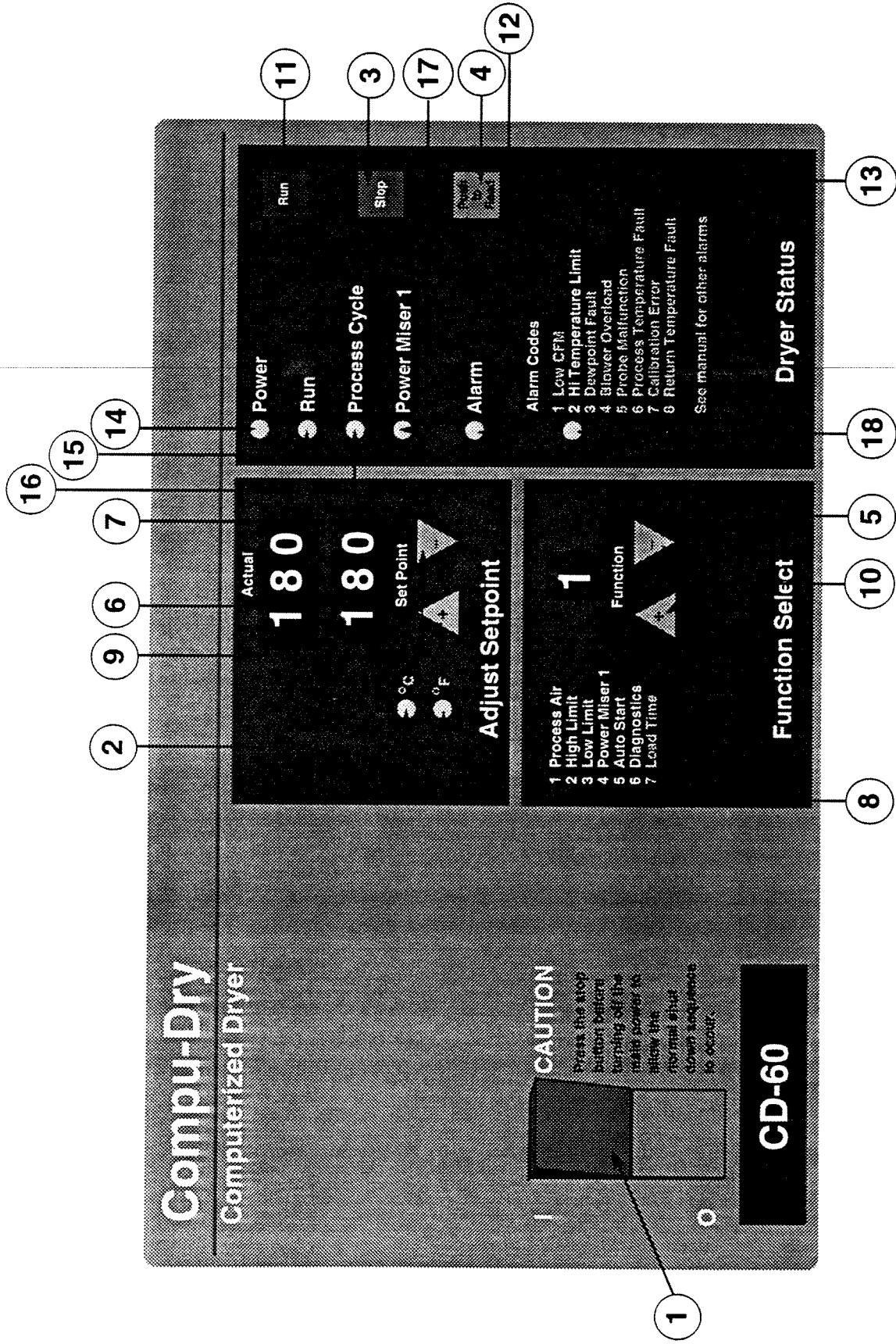
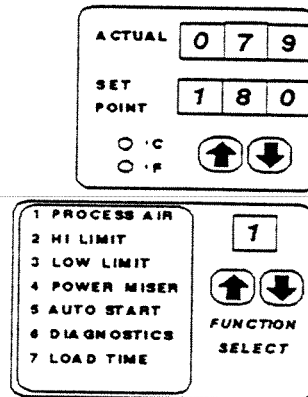

Figure 6

DRYER START-UP (Figure 6)

Function Set-up:

By switching the "ON/OFF" or the reset switch (Item #1) to the ON position, the power on light (Item #14), and LED displays (Items #5, 6 & 7) will be energized as follows:



Depending on how your unit was set up, the Degree "C" or the Degree "F" LED will be on. The function display (Item #5) has been designed to give the operator an indication as to what function is being monitored or displayed at any time.

The word "Function" refers to the parameters listed in Item #8, of which the first three relate to the process circuit of the dryer. The remaining three parameters relate to other functions of the dryer. With the Function display (Item #5) indicating Function #1 "Process Air", we may increase or decrease the setpoint by using the setpoint up and down keys (Item #9). As you press the setpoint up and down keys, you will see the "Setpoint" display (Item #7) scroll accordingly. There are two scrolling speeds designed into the control. When the setpoint up and down keys (Item #9) are pressed, the first scrolling is invoked. After 5 seconds, the faster speed is invoked. The following is a list of all functions, along with a brief description and setup procedure for each one.

FUNCTIONS:

1. Process Air - Process delivery air temperature should be set for the material being processed (eg. ABS at 180°F). As before with the function display (Item #5) indicating Function #1, use the setpoint up and down keys (Item #9) to adjust the setpoint to the desired process air temperature. The actual display (Item #6) displays the actual process temperature as seen by the process RTD.

*2. Hi Limit - This function safeguards against someone raising the process air setpoint above an acceptable level for a given material. The process air setpoint cannot exceed the "Hi Limit" setting. Therefore it is impossible to raise the process setpoint above the "Hi Limit". This number may be any number greater than or equal to the "Process Air" setpoint (400°F maximum). A safe setting normally would be 10 degrees above the "Process Air" setpoint.

*3. Lo Limit - This function is similar to the "Hi Limit". The setting may be any number less than or equal to the "Process Air" setpoint (100°F minimum). A safe setting would normally be 10 degrees below the "Process Air" setpoint.

* These functions require an access code in order to change the setpoint. With an access code of 054, it is possible to raise or lower the setpoint.

The access code can be entered at any time. Press the function down key (Item #10) until the function display (Item #5) indicates #6. While in diagnostics (Function #6), use the setpoint up key (Item #9) until the setpoint display reads 054. Then scroll up to the desired function to be adjusted by pressing the function up key (Item #10). Once you have adjusted both Hi and Lo Limits to the desired settings, you can reset the access code to read 000 or the unit will automatically reset after a two-minute timer counts down.

4. Power Miser 1 (optional) - Setpoint display (Item #7) will read noP if not installed. This function relates to Power Miser 1 "Deluxe". This option is for extending the process cycle time of your dryer by measuring the process dewpoint. If this option has been factory installed, it has been pre-adjusted to -3°F. This is an acceptable setpoint for most materials, but you may adjust the setpoint should your application require a different setpoint. With the function display (Item #5) indicating Function #4, use the setpoint up and down keys (Item #9) to adjust to the desired setpoint. It is adjustable from -40°F to 0°F.

5. Auto Start - This function permits automatic startup at the predetermined time. It is adjustable from 0 to 150 hours. With Function display (Item #5) indicating #5, enter the number of hours before the dryer is to start by using the setpoint up and down keys (Item #9). Then by pressing the "RUN" key (Item #11), the timing cycle will start. The actual display (Item #6) will read "on" and the run LED (Item #15) will flash on and off to give operator the indication of "Auto Start" in process.

CAUTION: Make sure the temperature parameters are properly adjusted before using this function. Failure to do so could result in severe damage to your material.

The timer must be reset each time you wish to use this feature. On power interruptions, the microprocessor retains where the timer left off and will resume the countdown once power is restored.

To deactivate the auto start timer, press the "STOP" (Item #3). Then, with Function display (Item #5) indicating #5, set the timer to zero by using the setpoint down key (Item #9).

6. Diagnostics - This function is reserved for entering access codes and setup codes for various functions. These codes are referred to throughout the manual as required.

Secondary Functions

These functions are not listed on the control label but may be needed by the operator for certain applications. To access these functions, with the Function display (Item #5) indicating #6, use the setpoint up key (Item #9) to enter access code of 064. Then by pressing the function down key (Item #10), you can scroll through each function you wish to view. The following is a list of all secondary functions along with a brief description and setup procedure for each one.

1. Return Air - This function is not adjustable and is for monitoring the temperature of the return air from the drying hopper. Your dryer has been equipped with this feature to prevent and protect your dryer from high return air temperatures, which could damage the dryer's blower. Also to alert the operator to the possible need for a return air aftercooler (See Hi Temperature D60 Dryer section in this manual).

2. Software Version - This function simply displays the software version number shown in the setpoint display (Item #7). This function may be needed when contacting Conair Franklin Service Department for information on your dryer and will be helpful to know what software version is installed in your dryer without having to open the control box to check the software version on the actual chip.

3. Access Code - This function is for access code of 054, which is needed to adjust the Hi and Lo Limit functions of your dryer. If you do not want to have to enter an access code of 054 each time to adjust the Hi and Lo Limit, you can turn this function off. This can be done with the actual display (Item #6) indicating "Acc". Press the setpoint down key (Item #9) so that the setpoint display (Item #7) reads "off". After doing this, it will no longer be necessary to enter an access code of 054 to adjust the Hi and Lo Limit.

4. SPI Interface (optional) - If this option has not been installed, the setpoint display (Item #7) will read "noP". This is the display if you communicate with RS232.

If this option has been installed, the setpoint display (Item #7) will read 3.01. This is the SPI version installed in your unit. If you use RS485 to communicate with, this is what should be displayed.

5. Baud Rate - This function is for adjusting the Baud Rate for your communication needs. For RS232 it is adjustable from 3 to 96, which indicates 300 to 9600. For RS485, the adjustment is from 12 to 96, which indicates 1200 to 9600. To adjust the Baud Rate with the actual display (Item #6) indicating "bau", use the setpoint up and down keys (Item #9) to adjust to the desired Baud Rate.

6. Node Address - This function is also for communication purposes. It is adjustable from 032 to 064. This allows you to give 32 separate unit addresses for communication. To adjust the Node address with the actual display (Item #6) indicating "nod", use the setpoint up and down keys (Item #9) to adjust to the desired node address.

Once all functions have been adjusted properly, the dryer may be started by pressing the "RUN" key (Item #11). Upon mstarting the dryer, the "RUN" LED (Item #15) and "Process Cycle" LED (Item #16) will be energized. If any malfunction occurs, the "Alarm" LED (Item #12) will be energized alerting the operator. By pressing the "Push to Read" key (Item #4), the nature of the malfunction will be indicated in the setpoint display (Item #7). For example:

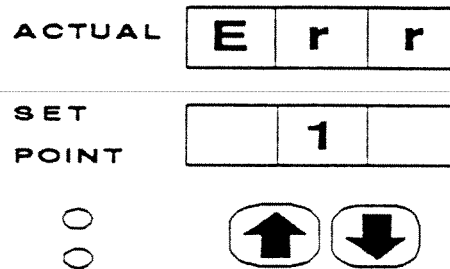

This indicates error message #1, which indicates Alarm #1 Low CFM.

NOTE: The display will stay energized for three seconds after the "Push to Read" key (Item #4) is pressed.

The alarm conditions are listed in Item #13 on the control label.

NOTE: Some alarms are passive while others are shut down alarms (see Troubleshooting At end of manual).

While the dryer is running, there are LED's (Items #16 & 17) which advise the operator what cycle and options are being energized during operation. It should be noted that the LED for the optional function (Item #17) will not be energized unless the option has been installed.

To shut the dryer down, the "STOP" key (Item #3) should be used rather than the "ON/OFF" switch (Item #1). This is done to utilize the programmed shutdown mode which de-energizes the heater for three minutes prior to de-energizing the blower. Once the dryer is shut down, the "ON/OFF" switch (Item #1) can be turned to the "OFF" position.

MAINTENANCE

Filters:

The process, regeneration and cooling filters serve to protect the desiccant from contamination by dirt, dust and fines. If contamination occurs, drying efficiency will be severely diminished. Therefore, it is very important that the filter canister be cleaned at regular intervals. Length of time between cleanings will depend on the type of granulate being processed and the work environment, but typical intervals range from three to fourteen days.

Then plastic material being processed contains a large proportion of dust and fines, optional auxiliary filter is recommended.

TO CLEAN FILTERS:

Process Filters - First, shut down dryer. This must be done so that dirt and humidity are not drawn into the drying circuit. Then, remove filter housing from top of dryer and slide out filter cartridge. Use compressed air to blow the dirt and fines out. Always blow from inside-out. Make sure filter is properly seated.

Regeneration and Cooling Filters - These filters should be cleaned in a similar manner as the process filters.

NOTE: During cleaning, check carefully for holes and tears in filter paper. If defects are found, replace old filter with new one before placing dryer back into operation. New filter cartridges may be ordered from Conair.

Contamination is the principal cause of desiccant failure; if the desiccant cartridge should become contaminated, drying efficiency will be reduced.

Desiccant Cartridge Replacement (See Figure 1)

The desiccant cartridge is located below the heater box in the desiccant cartridge housing. Remove the 6 hex bolts which join the heater box and the desiccant cartridge housing. Remove the heater box and swing it to the side (as electrical connections permit). The desiccant cartridge will now lift up out of its housing. Install new tank and reverse above procedure to re-assemble.

HEATING ELEMENTS

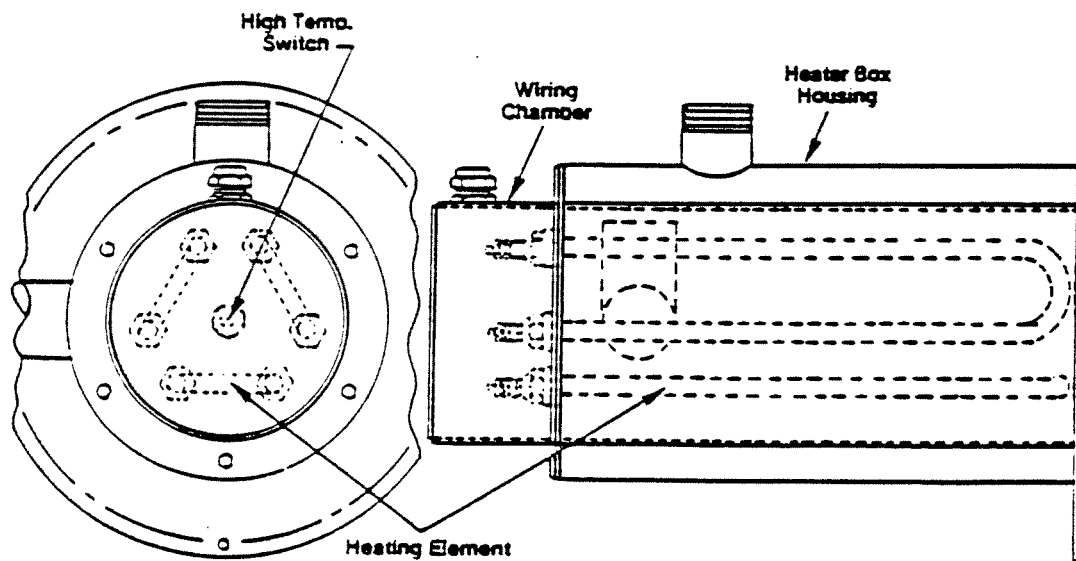

HEATER BOX ASSEMBLY

The heating elements in your Conair dryer require no routing maintenance. After a very long term of service, however, elements may eventually require

replacement. Should the elements need replaced, care should be taken in rewiring the new elements the same as the defective ones.

CAUTION: Before servicing dryer, be sure to switch main disconnect to "OFF" position.

Lubrication

All motors are lubricated for life, and require no lubrication.

Check Valve Maintenance-

The check valves used in the dryer do not require any regular maintenance, but if it becomes necessary to remove them, care should be taken when they are re-installed, in order that the valve is positioned in such a fashion that the check plate will swing straight down. If the valve is tilted, there is the possibility of binding.

MAINTENANCE CHECKLIST FOR DRYERS

Important points which should be checked on a periodic basis:

Air Circuits-

1. Are the hoses in good condition?
2. Do all the hoses have a proper fit on the dryer and hopper?
3. Are all the gaskets in place and in good condition (on drying hoppers and on filters)?
4. Are all the hoses properly connected, not only externally but also internally?

It is important to maintain a "closed-loop" system in order to avoid high moisture-laden ambient air from entering the system and prematurely loading the desiccant tank. Under operating conditions, normally the return dew-points will be between 0°F. and +20°F. with a closed system. Under these same conditions, the ambient dewpoint may be +65°F.

Filter Condition -

Dryer must be shut off prior to removal of filters to avoid drawing fines and/or dust into blowers and desiccant tanks.

1. Are the process filters clean and sealing properly?
2. Is the regeneration filter clean?
3. Is the cooling filter clean?

In order to have the amount of air flow necessary for proper regeneration and processing, the filters must be relatively clean. Cleaning of the filter should be done quite frequently when first installed until some logical cleaning schedule can be determined, depending on such variables as rates of material being processed, fines in the material, and amount of regrind material being used with virgin.

Regeneration Temperature-

In order to get the proper temperature profile across the desiccant tank, we need to have an inlet temperature of 425°F. This, in conjunction with the proper air flow, are the two main points for adequate regeneration. Check the heater element amperage (check electrical diagram for specifications on your particular model):

<u>Heaters</u>	<u>Blower</u>
L1 _____	T1 _____
L2 _____	T2 _____
L3 _____	T3 _____

Tanks must be packed properly using the correct procedure and desiccant. Proper drying may be negated by using incorrect packing procedure or desiccant. Conair has a trade-in exchange program for routing replacement of tanks - call Conair Parts Department toll free at 1-800-458-1960 for details.

Blower Rotation-

The rotation is merely checked by determining whether the pressure at the inlet of process filter is negative. If there is no air flow, this would indicate the regeneration mode and the regeneration/cooling cycle light on the front of the control panel should be energized. Should the rotation be incorrect, simply reverse any two (2) of the three (3) power leads.

Voltage-

1. Does line voltage agree with nameplate voltage?
2. Is voltage in secondary side of transformer wired for 115 volt?

Return Line Air Temperature-

What is the return air line temperature from the top of the drying hopper to the dryer? This temperature should not exceed 130-140°F. It may be necessary to use a return air line cooler (consult Conair).

This checklist is a general guideline for servicing the automatic dehumidifying dryers manufactured by Conair. Understanding the basic points which are outlined should make the troubleshooting and maintenance of the dryer easier.

ALARM DISPLAY	MALFUNCTION	SOLUTION	AUTOMATIC SEQUENCE IF MALFUNCTION OCCURS
<p>ALARM DISPLAY</p> <p>ACTUAL E r r</p> <p>SET POINT 1</p> <p>°C °F</p> <p>← →</p>	<p>* LOW CFM</p> <ul style="list-style-type: none"> - Incorrect blower rotation. - Check valves may be clogged. 	<p>- If blower rotates in the wrong direction, reverse any two leads at the main disconnect.</p> <ul style="list-style-type: none"> - Check the valves, and replace if necessary. 	<ul style="list-style-type: none"> - Dryer shuts down and alarm light is energized.
<p>ACTUAL E r r</p> <p>SET POINT 2</p> <p>°C °F</p> <p>← →</p>	<p>* HI-TEMP LIMIT</p> <ul style="list-style-type: none"> - The high temperature limit has been exceeded during the process or regeneration cycle due to an abnormally high temperature in the heater box. - Faulty high temperature probe. 	<ul style="list-style-type: none"> - Check the heater box for signs of excessive heat. - Clear any restricted hoses. - Check for proper air flow in both circuits. - Check probe for obvious damage and replace if necessary. 	<ul style="list-style-type: none"> - Dryer shuts down and alarm light is energized.
<p>ACTUAL E r r</p> <p>SET POINT 3</p> <p>°C °F</p> <p>← →</p>	<p>DEWPOINT FAULT</p> <ul style="list-style-type: none"> - Dryer is not producing the proper dewpoint. - Desiccant may be contaminated. - System may be improperly installed. - Stuck check valve. 	<ul style="list-style-type: none"> - Check the valve and replace if necessary. - Consult Conair. 	<ul style="list-style-type: none"> - Alarm light is energized.
<p>ACTUAL E r r</p> <p>SET POINT 4</p> <p>°C °F</p> <p>← →</p>	<p>BLOWER OVERLOAD</p> <ul style="list-style-type: none"> - The overload on the blower has tripped. This could be caused by not having the overload properly adjusted, or the motor may be drawing excessive current. 	<ul style="list-style-type: none"> - Check the overload setting and adjust if necessary. - Reset the overload. - Check motor current against the name plate current to insure the motor is not drawing excessive amperage 	<ul style="list-style-type: none"> - Dryer shuts down and alarm light is energized.
<p>ACTUAL E r r</p> <p>SET POINT 5</p> <p>°C °F</p> <p>← →</p>	<p>* PROBE MALFUNCTION</p> <ul style="list-style-type: none"> - Either the temperature sensor has not been properly connected to the control box or the sensor is defective. 	<ul style="list-style-type: none"> - Check the connection. - Check the probe for obvious damage and replace if necessary. 	<ul style="list-style-type: none"> - Dryer shuts down and alarm light is energized.

ALARM DISPLAY	MALFUNCTION	SOLUTION	AUTOMATIC SEQUENCE IF MALFUNCTION OCCURS
<p>ACTUAL [E] [r] [r]</p> <p>SET POINT [] [] [6]</p> <p>○ °C ○ °F</p> <p>⬆ ⬇ ⬆</p>	<p>* PROCESS TEMP FAULT</p> <ul style="list-style-type: none"> - The process temperature is above or below an acceptable level. - The process temperature setting is too high for the dryer to maintain temperature at the set point. - Dryer may be too far from the hopper. - Air flow may be reversed. - Heaters may be defective. - Process temperature probe may not be properly positioned. - Supply voltage may be different than the name plate voltage. 	<ul style="list-style-type: none"> - Check heater amperage for defective heaters. - Check air flow direction. - Make sure the process temperature sensor is positioned at the inlet of the drying hopper. - Check supply voltage against name plate voltage. - Consult Conair for additional assistance. 	<p>- Dryer shuts down and alarm light is energized.</p>
<p>ACTUAL [E] [r] [r]</p> <p>SET POINT [] [] [7]</p> <p>○ °C ○ °F</p> <p>⬆ ⬇ ⬆</p>	<p>* CALIBRATION ERROR</p>	<ul style="list-style-type: none"> - Press PUSH TO READ to clear the error message. Press STOP, then turn the power off and back on. Press RUN to resume normal operation. - If you can't clear the error message after pressing PUSH TO READ, consult Conair. 	<p>- Dryer shuts down and alarm light is energized.</p>
<p>ACTUAL [E] [r] [r]</p> <p>SET POINT [] [] [8]</p> <p>○ °C ○ °F</p> <p>⬆ ⬇ ⬆</p>	<p>A - RETURN AIR TEMP UNSATISFACTORY</p> <ul style="list-style-type: none"> - Return air temperature is above 150° F. <p>B - RETURN AIR TEMP ABOVE LIMIT</p> <ul style="list-style-type: none"> - Return air temperature is above 180° F. 	<ul style="list-style-type: none"> - Insure hopper is full of material. - Add aftercooler if one is not already part of the system. - If aftercooler is present, check coils and clean if necessary. 	<ul style="list-style-type: none"> - Above 150° F, dryer alarm is energized. - Above 180° F, dryer shuts down and alarm light is energized.
<p>ACTUAL [E] [r] [r]</p> <p>SET POINT [] [] [9]</p> <p>○ °C ○ °F</p> <p>⬆ ⬇ ⬆</p>	<p>MATERIAL LEVEL TOO LOW</p> <ul style="list-style-type: none"> - The conveying filter may be clogged. - The conveying blower maybe phased incorrectly. - Improper insert inside the distribution box. - Improper hose connections or air leaks in the hoses. - Demand sensor may need readjusted, or sensor may be faulty. 	<ul style="list-style-type: none"> - Check and clean the conveying filter. Replace the filter if it is torn or hopelessly clogged. - Check the blower rotation. If necessary, reverse any two leads at the main disconnect. - Make sure the proper material insert is inside the distribution box. - Check conveying hoses for proper connections, or any damage. Replace if necessary. - Check the demand sensor and replace if necessary. 	<p>- Alarm light is energized.</p>

ALARM DISPLAY	MALFUNCTION	SOLUTION	AUTOMATIC SEQUENCE IF MALFUNCTION OCCURS
<p>ACTUAL </p> <p>SET POINT </p> <p>°C </p> <p>°F </p>	<p>* CHECKSUM ERROR</p> <ul style="list-style-type: none"> - Electronic noise - Calibration error 	<ul style="list-style-type: none"> - Press PUSH TO READ to clear the error message, then press PUSH TO READ a second time to clear error message 7. Press STOP, then turn power off and back on. Press RUN to resume operation. 	<ul style="list-style-type: none"> - Dryer shuts down and alarm light is energized.
<p>ACTUAL </p> <p>SET POINT </p> <p>°C </p> <p>°F </p>	<p>IMPROPER SHUT DOWN</p> <p>One of the following situations removed power to the dryer before it completed its cool-down cycle.</p> <ul style="list-style-type: none"> - Someone stopped the dryer incorrectly by pressing the power ON/OFF switch instead of the STOP key. - A shut down alarm. - A power outage. 	<ul style="list-style-type: none"> - Always use the STOP key to shut down the dryer. - Press PUSH TO READ to clear the error message, then press RUN to resume normal operation. - Press PUSH TO READ, if another error message appears, refer to the alarm code in this section to determine what shut down the dryer. - Check the dryer power supply. 	<ul style="list-style-type: none"> - Alarm light is energized.

① By pressing the “PUSH TO READ” key, the nature of the malfunction will be shown on the display.

* When this alarm condition exists, you will need to switch the dryer OFF to reset the unit. If the malfunction has been corrected, the it will exhibit normal conditions when restarted. If, however, the malfunction is not corrected, the unit will go into an alarm condition.

NOTE 1: For safety reasons, error #2 bypasses the microprocessor. If the error occurs, ERR 2 will not appear in the top display until the temperature has fallen below the trip point. During the this time, the red LED to the left of the “HI-LIMIT” message will be energized.

HIGH TEMPERATURE DRYER INSTRUCTIONS

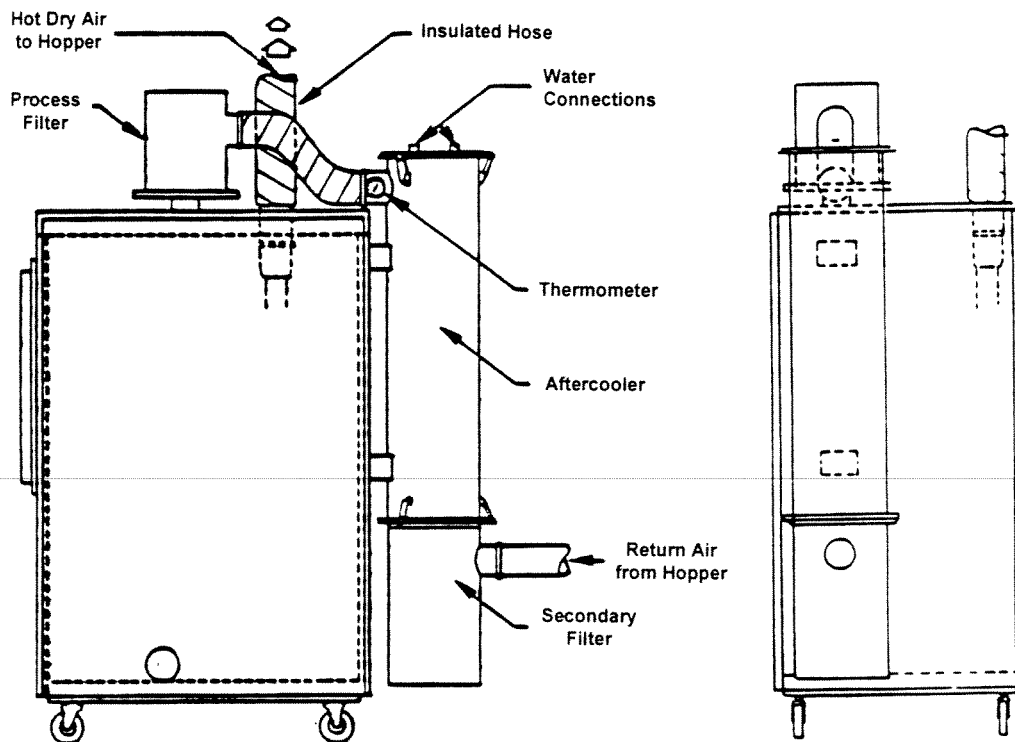

HIGH TEMPERATURE ARRANGEMENT

GENERAL:

Essentially the high temperature dryer is the same as the standard dryer with the exceptions of several auxiliary parts necessary to properly handle the higher temperature. These auxiliary parts will be discussed in further detail in the following paragraphs.

The high temperature dryer is intended to be used in application where the drying temperatures range from 150°F to 350°F. Higher temperature ranges can be achieved. To do this, consult Conair for proper sizing.

Auxiliary Equipment:

The auxiliary equipment necessary for high temperature drying include:

Aftercooler - Utilizing city or tower water in the range of 55°F to 70°F, we cool the return air from hopper to an acceptable level before introducing it back into the desiccant tank where moisture is removed from the cool air. In a few cases where material rates are low, it may be necessary to use 40°F coolant temperatures supplied by a chiller in order to lower the high return temperatures. In any case, the flow rates of the cooling agent will range from 1 to 3 GPM. The dryer will operate most efficiently with return air temperature in the area of

125°F to 130°F. This temperature can be monitored at the outlet of aftercooler with the standard in-line thermometer. Pipe couplings are built into the aftercooler in order to hose the water into the coil. Flexible hoses are most suitable for allowing the dryer to be easily moved.

Secondary Filter - This filter eliminates the need of constantly cleaning the aftercooler coils by simply removing the dirt and fines which may accumulate from the material being dried. It is important, therefore, that the filter be placed on the inlet of the aftercooler and not the outlet. (See Figure 8) Cleaning of the filter should be done quite frequently when first installed until some logical cleaning schedule can be determined depending on such variables as rates of material being processed, amount of dirt and fines in the material and amount of virgin material being used versus regrind.

Insulated Hose - In order to reduce the temperature drop of the drying air coming from the dryer to drying hopper, an insulated hose is used. It is important that this hose be placed on the delivery side (air to hopper) and not the return side (air coming back to dryer) of the dryer.

All other components necessary for high temperature drying are build into the dryer.

OPERATION:

Because of the higher temperature, prolonged periods of residence time in drying hopper at high temperature should be avoided. If it is necessary to stop operation for some time, the temperature should be lowered in order to avoid bridging (material becoming soft and tacky and sticking together, not allowing an even flow in hopper).

This information is supplied in conjunction with the standard instruction manual. The basic operating sequence and electrical data has already been covered in the standard manual.

{GRAPH HERE}

CALL TOLL-FREE FOR CONAIR REPLACEMENT PARTS AND SERVICE

Wants Line 800-458-1960 is your direct line to the Conair Parts Department. Help in identifying the parts you need is available through that department. Service related calls should be made to 800-888-9046.

CONAIR GUARANTEE

Conair guarantees the machinery and equipment described herein for a period of one year from date of shipment against defects in material and workmanship, under the normal use and service for which it was recommended; except filters, flexible material conveying hose, and liners for valves in material lines. Conair's guarantee is limited to repairing or replacing, at our option, the part or parts determined by us to be defective after examination of the part or parts. The customer assumes the cost of transportation of the part or parts to and from the factory. **THERE ARE NO WARRANTIES, EXPRESS, IMPLIED, OR STATUTORY, OTHER THAN AS EXPRESSED HEREIN.** No liability for any special, indirect, or consequential damages of any nature is assumed by or shall be imposed on Conair based on its undertakings herein.

CONAIR SERVICE COMMITMENT

Conair equipment is built to give long, reliable, efficient service if it is installed, operated and maintained properly. Occasionally, you may require help from Conair's Service Department in making minor field corrections or in correcting operating malfunctions.

During normal business hours there is a Conair Service Man available by phone to discuss any service problem you may have: Call (814) 437-6861.

Before calling, check the Troubleshooting Guide in this instruction book to see if corrective action is described. If not, try to determine which part of a normal cycle is not operating properly. Note the model number and serial number of the unit and keep this instruction book handy for reference during the call.

If you need a Conair Serviceman, He'll be there fast! We know you need prompt attention. Most service calls are made within a few days from the request, often, because Conair has several factory-based servicemen in the field every week, you will get attention even faster. During your call to the Service Department it will

be determined if a visit is needed at your plant. You will be asked to give us a purchase order number to cover the cost of a service call if the problem is not covered by the equipment Warranty or Performance Guarantee. Calls made to cover such warranty or guarantee items are made at Conair's expense. The Service Department will detail current service costs, if any.

He stays until the job is done! Conair Servicemen are instructed to stay at your plant until you're satisfied that the difficulty has been corrected or your personnel know what to do should correction depend upon receipt of replacement parts. We know that good service often helps sell the next Conair units you buy . . . so we do everything we can to make it the best service in the industry.

We'll help train your people too! Conair will be pleased to quote, and arrange for, instruction sessions in your plant on the operation and maintenance of your Conair Equipment. Such training sessions may be arranged through the Service Department. (814) 437-6861

CONAIR PERFORMANCE WARRANTY

Conair warrants that this equipment will perform at, or above, the capacities as stated in specific quotations covering the equipment or as detailed in engineering and sales literature as long as the equipment is applied, installed, operated and maintained in the recommended manner as outlined in either a quotation or in literature.

Should performance not meet claimed levels, Conair, at its option, will:

1. Make an inspection of the equipment by a qualified representative and perform alterations or adjustments to satisfy performance claims. (Charges for such inspections and corrections will be waived unless poor performance is due to misapplication, improper installation, maintenance or operation), or . . .
2. Replace the original equipment with other Conair equipment which will meet original performance claims at no extra cost to the customer, or . . .
3. Refund the invoiced cost of the equipment. Credit is subject to prior notice by the customer at which time a Return Goods Number will be issued by Conair's Service Department. Returned equipment must be well crated. Returns must be prepaid.

