

Mobile Drying & Conveying Unit

Model MDC-30

User Guide

CONAIR

FRANKLIN

Part of the Conair Group

Route 8 North
Franklin, PA 16323
814-437-6861
Fax: 814-432-6227
Service: 800-888-9046
Parts: 800-458-1960

UGD008/1095



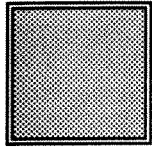
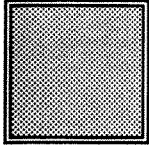

Table of Contents

Section 1	Introduction	
	Warranty	1
	This is the MDC30 Dryer	2
	Conventions	3
	Customer Support	4
	Intended Uses & Limitations	5
<hr/>		
Section 2	Installation	
	Electrical	6
	K-Loader Mounting Bracket	7
Section 3	Operation	
	Control Layout	8
	Control Operation	9-11
	Pre-drying Operation	12
	Moving the MDC30 Dryer	13
	Conveying Operation	14
Section 4	Maintenance Items	
	Filter Cleaning	15
	O-ring and Hose Inspection	16
	Hopper Draining and Cleaning	17-18
Section 5	Troubleshooting	
	Troubleshooting Guide	19-22





This is the MDC30 Dryer

The MDC30 dryer is a self contained mobile unit designed to dry plastic pellets and convey them with dehumidified air to a molding machine. The MDC30 dryer consists of the following components:

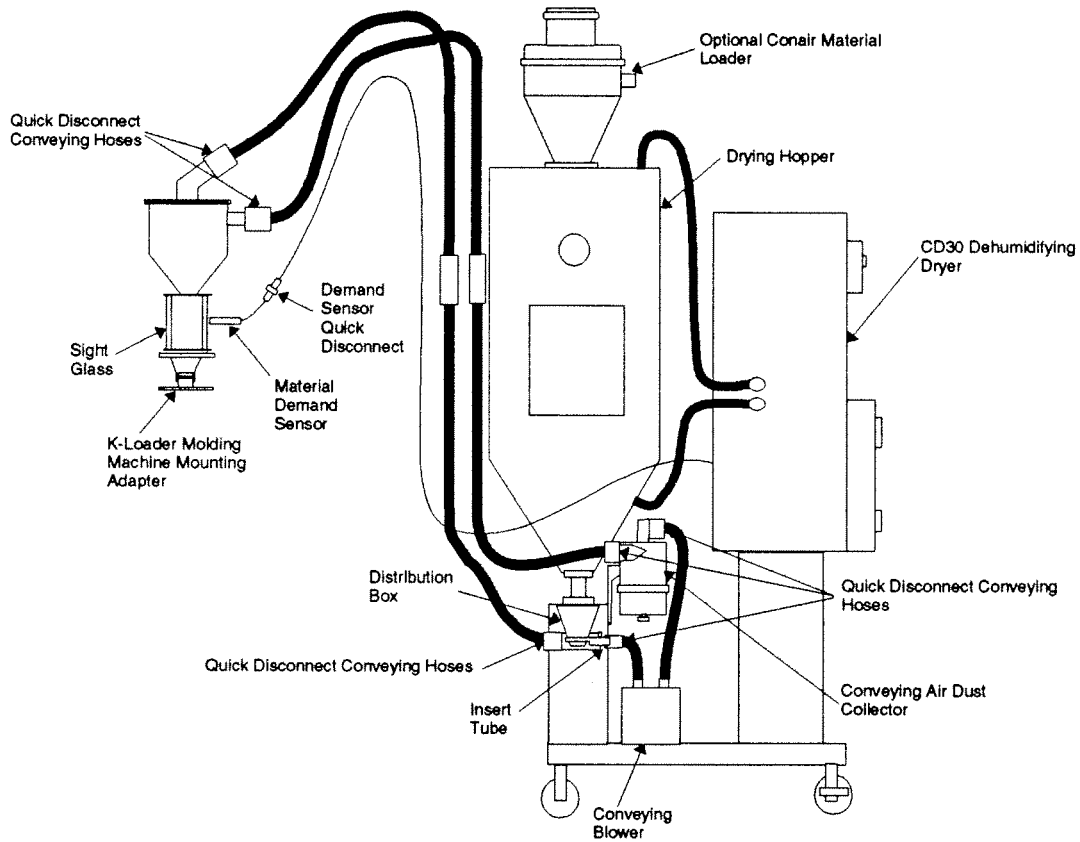

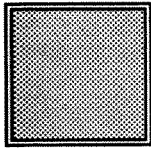

Conventions

The following conventions are used throughout this manual:

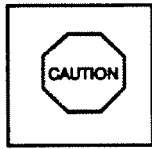

Symbols in stop sign shapes are used to indicate hazardous or potential equipment damage risks.

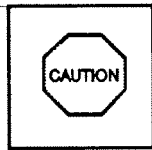

CAUTION: (General) STOP. Read instructions.



CAUTION: (Electrical Hazard) STOP. Do not proceed without safeguarding against electrical shock. Ensure that electrical power is shutoff before proceeding.

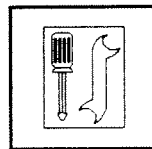

This symbol will indicate that there may be tools required to perform a function. Following this symbol will be a list of the tools required.

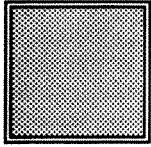

Customer Support

CONAIR FRANKLIN has support services available to help you in case you have a problem with your MDC30 Dryer. The following are suggested places to turn to for support.

If you encounter difficulty, begin by contacting the person who sold you your MDC30 Dryer, Your sales representative is familiar with your application and should be able to provide you with the information you need.

If your Sales Representative is unable to answer your questions, CONAIR FRANKLIN has Customer Service available to you. It is available from 8 am - 5 pm (EST), Monday through Friday. CONAIR's support staff will be more than happy to help you solve your problem. Your CONAIR FRANKLIN customer service number is:



1-800-888-9046

Before you call the CONAIR FRANKLIN customer service line, please make sure you do the following:

1. Check the "Troubleshooting" section of this manual.
2. Have the Manual in front of you when you call.
3. Have your MDC30 Dryer's model number and serial number when you call.

This will ensure a quick and efficient solution to your problem.

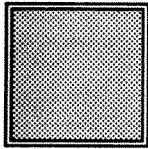

Intended Uses & Limitations

The MDC30 Dryer has been designed to be used beside the molding machine. The MDC30 Dryer will dry and convey plastic material at distances up to but not more than 8 feet vertically and 6 feet horizontally.

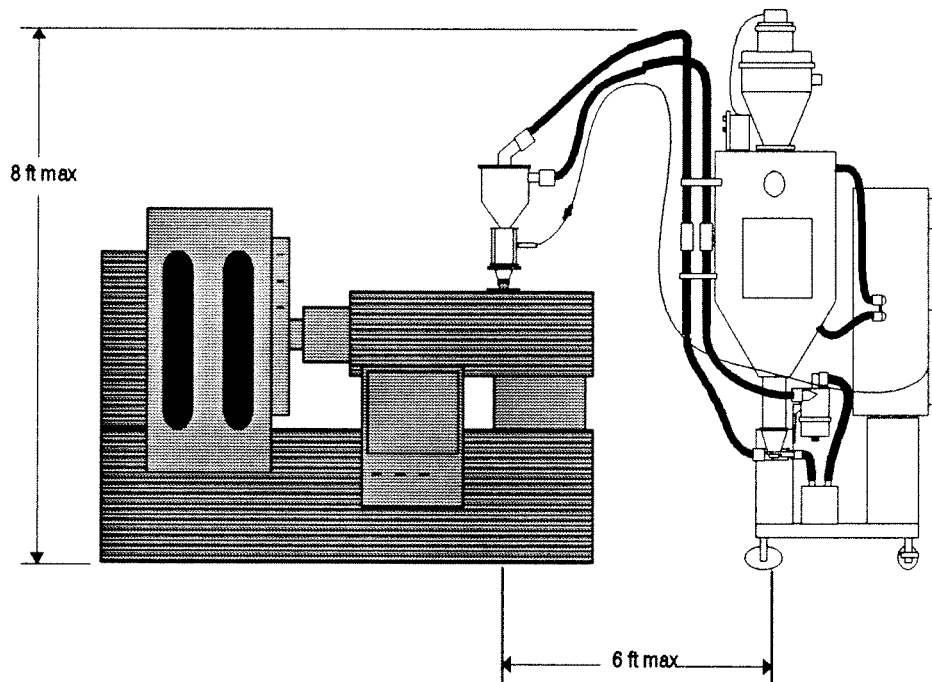

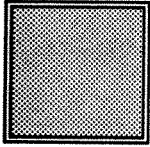

Electrical



Before power is connected to the unit, make sure the proper voltage, phase, frequency, full load amps, and minimum wire size meet the specifications stated on the nameplate mounted on the side of the dryer. Improper power supply could result in damage to the unit as well as serious injury to the operator. The voltage of the dryer is listed on the nameplate on the side of the dryer.

CONAIR FRANKLIN <small>PART OF THE CONAIR GROUP</small> FRANKLIN, PA.		
MODEL	_____	
SER. NO	_____	
PTS. LIST	_____	
VOLTS	PHASE	HZ
_____	_____	_____

Connect your power cord to the disconnect switch located in the control box. Use proper strain relief connections on the dryer to prevent cable abrasion and electrical disconnection.

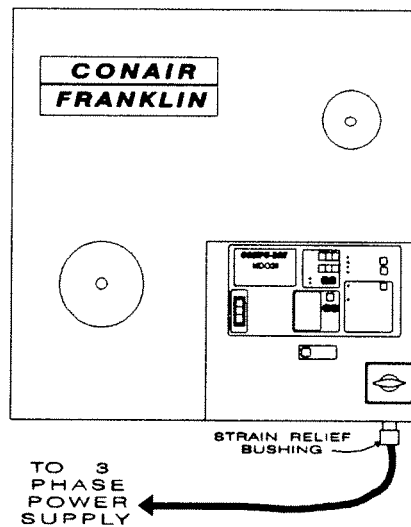

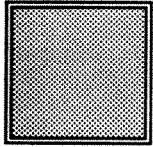

K-Loader Mounting Bracket

Included with the MDC dryer is a K-loader mounting bracket that will be used to mount the K-loader to the molding machine. The bracket is normally supplied with a blank base plate which may be drilled to match the molding machine's bolting pattern.

To mount the bracket:

1. Layout the bolting pattern for the feed throat of the press, on the mounting bracket.
2. Drill holes for the selected mounting bolts.
3. Using the selected mounting bolts, fasten the bracket to the molding machine feed throat.

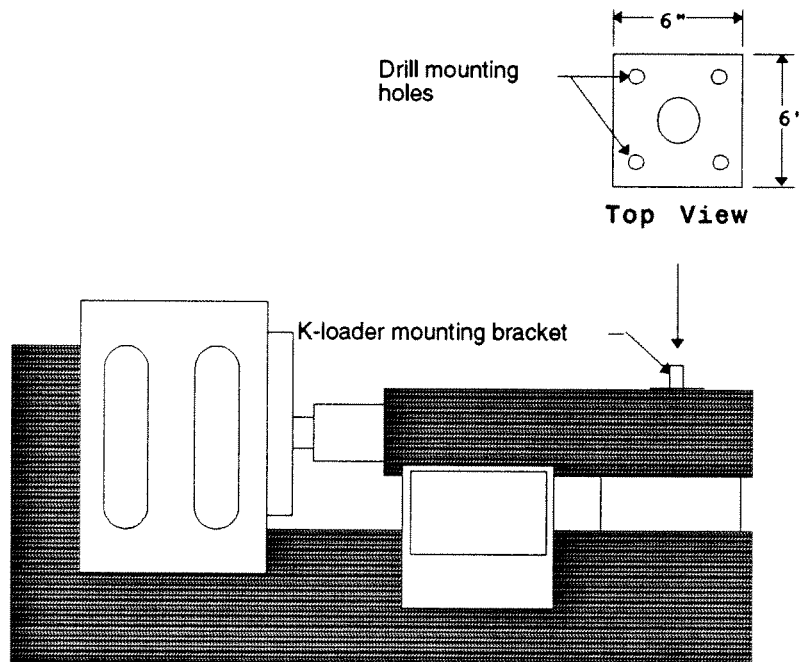

NOTE: If you require a larger mounting bracket, consult your CONAIR FRANKLIN sales representative for help.

MDC / K Loader Connector Adaptors

Original MDC units connected to their K Loaders with a green colored multi-pin Amphenol connector set.

As of 4/1/94, MDC units connect to their K Loaders with a *black* multi-pin AMP connector set.

Whichever MDC unit you have, you may have a need to connect to a K Loader matched to the *other style* MDC or to an independently purchased K Loader with a *dis-similar* connector.

The adaptors detailed here allow your MDC unit to connect to either style K Loader connector.

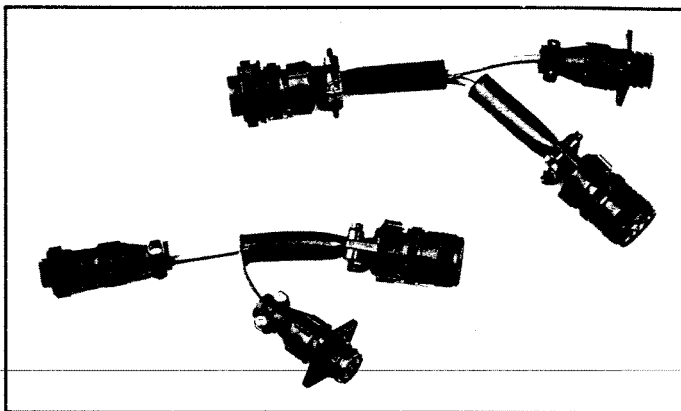

Each Adaptor set comes with dual 'pigtails' that allow the MDC to work with both new and old connector styles on K Loaders. You need only one adaptor for each MDC.

Selecting the Proper Adaptor

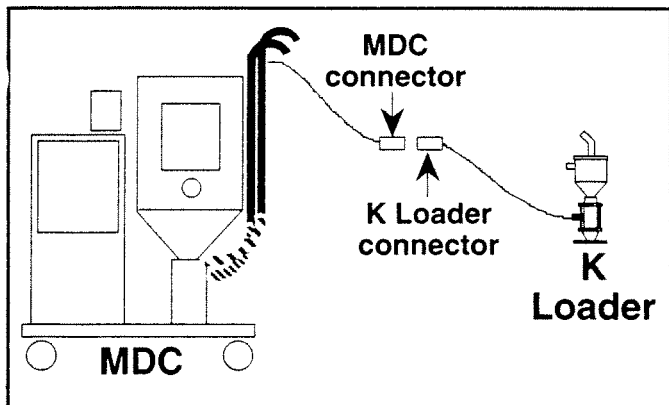

MDC Connector Color	Use Adaptor
Green	181-674-01
Black	181-674-02

Voltage Note:

Use only capacitance level sensors with an operating range up to 55 volts as listed on the sensor itself (see photo below).

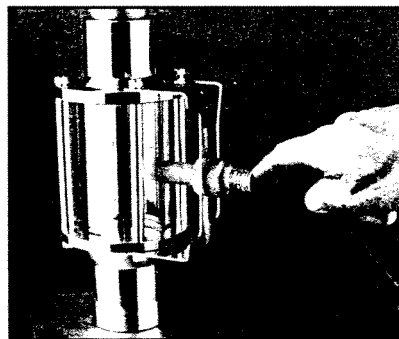

Do not use sensors with an operating range listed up to 250 volts. These are for K Loaders in other systems; not MDC systems.

Note: Although these adaptors are equipped with dual 'pigtails', they cannot be used to operate two loaders from one MDC.

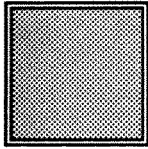

Control Layout

The control functions on the MDC30 Dryer that you will need to be familiar with are:

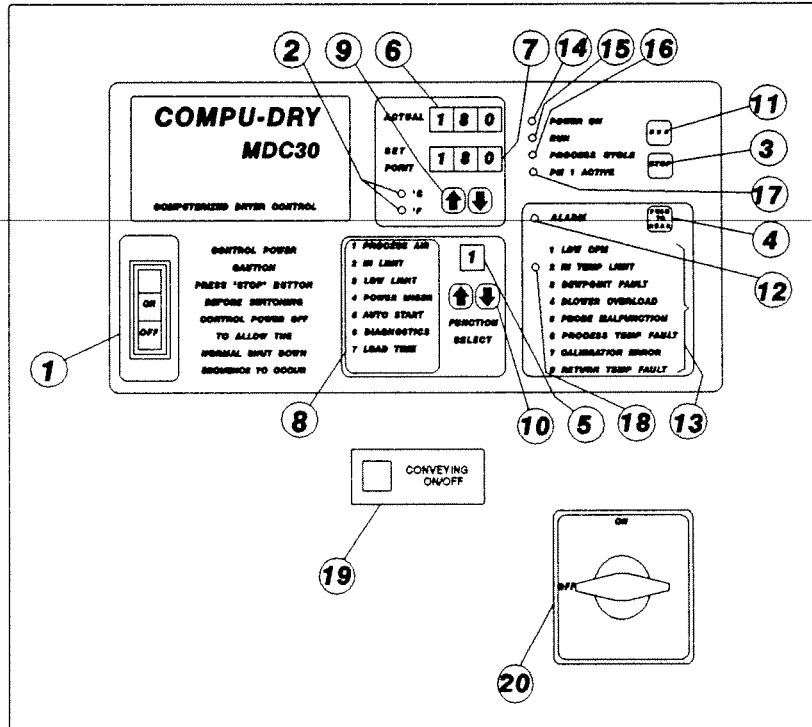

- | | |
|---------------------------------|----------------------------------|
| 1. Dryer ON/OFF Switch | 11. Run Button |
| 2. °C - °F LED | 12. Alarm LED |
| 3. Stop Button | 13. Alarm List |
| 4. Alarm "Press to Read" Button | 14. Power On LED |
| 5. Function Display | 15. Run LED |
| 6. Actual Display | 16. Process Cycle LED |
| 7. Setpoint Display | 17. PMI Active 8 LED |
| 8. Function List | 18. Hi Temp Limit LED |
| 9. Setpoint Up/Down Buttons | 19. Conveying On/Off Button |
| 10. Function Up/Down Buttons | 20. Electrical Disconnect Switch |

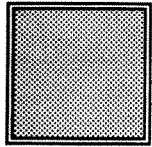

Control Operation

There are three basic procedures to run the dryer and conveying operations. The first procedure is to start the drying process.

STARTING THE DRYER

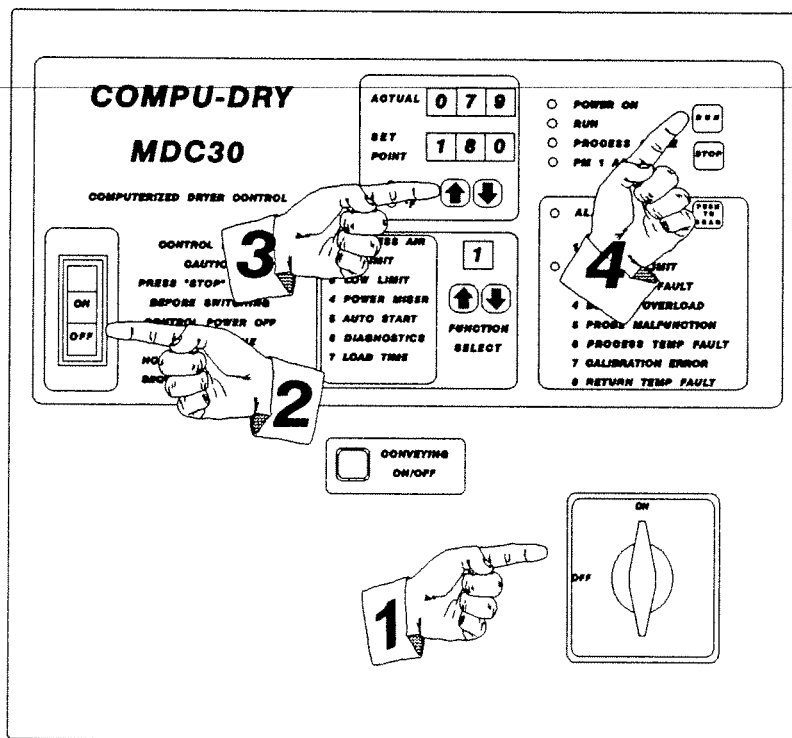

In order to start the unit:

1. Turn the disconnect to the "ON" position.
2. Turn the "ON/OFF" rocker switch to the "ON" position. The display should light to indicate power.
3. Use the setpoint adjustment buttons to adjust the process temperature to the desired setting.
4. Press the "RUN" button. The dryer should start to dry the material.

NOTE: Read and refer to your CD30 Dryer manual for complete dryer operation and maintenance.

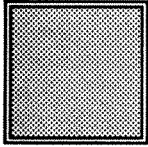

Control Operation

The second procedure is turning on the material conveying.

CONVEYING ON/OFF

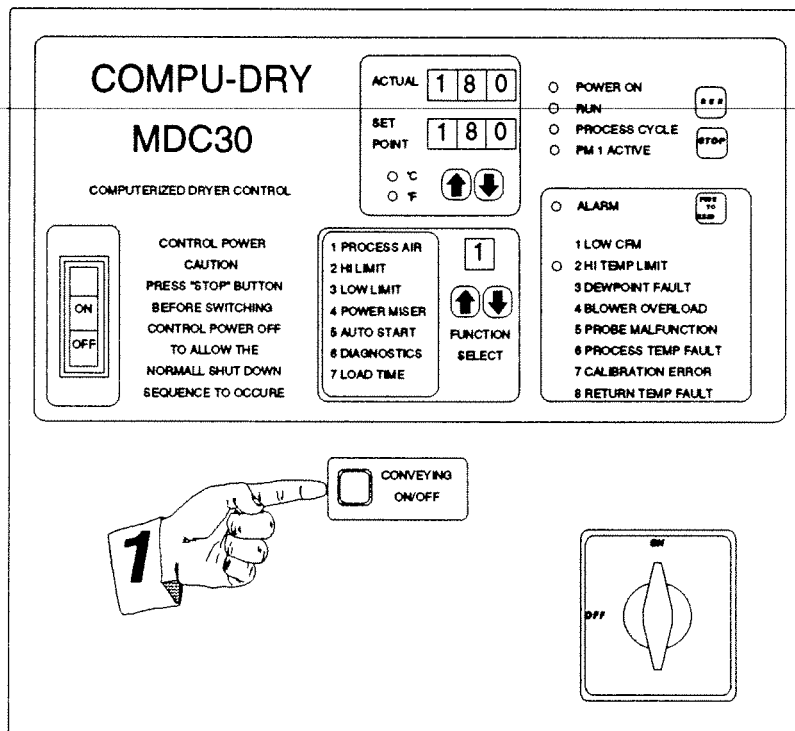

In order to start conveying material:

1. Press the "CONVEYING ON/OFF" button. The button will light and the MDC unit will start to convey material to the K-loader receiver until the demand sensor is satisfied.

NOTE: During the operation of the MDC unit, the light on the button will stay on.

2. In order to stop the conveying of material, press the "CONVEYING ON/OFF" button again. The light will go off to indicate that the conveying system is off.

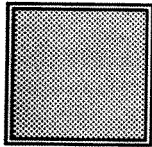

Control Operation

The third procedure is adjusting the load time. The load time is preset to 5 seconds. If it is necessary to change the load time, use the following procedure.

LOAD TIME ADJUSTMENT

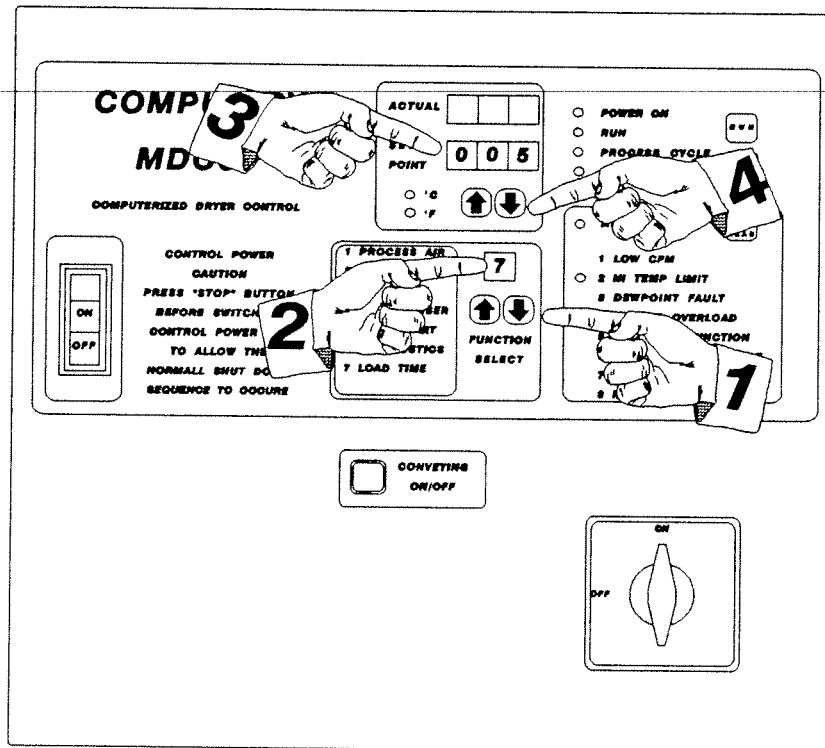

To adjust the load time:

1. Use the function select buttons to scroll to function "7".
2. Number 7 will appear in the function display.
3. "005" will appear on the setpoint display. This is the actual load time in seconds.
4. Use the Setpoint adjustment buttons to adjust the load time. The load time is adjustable between 3 and 15 seconds.

NOTE: Read and refer to K-loader for complete descriptions and adjustment of demand sensor.

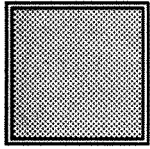

Pre-Drying Operation

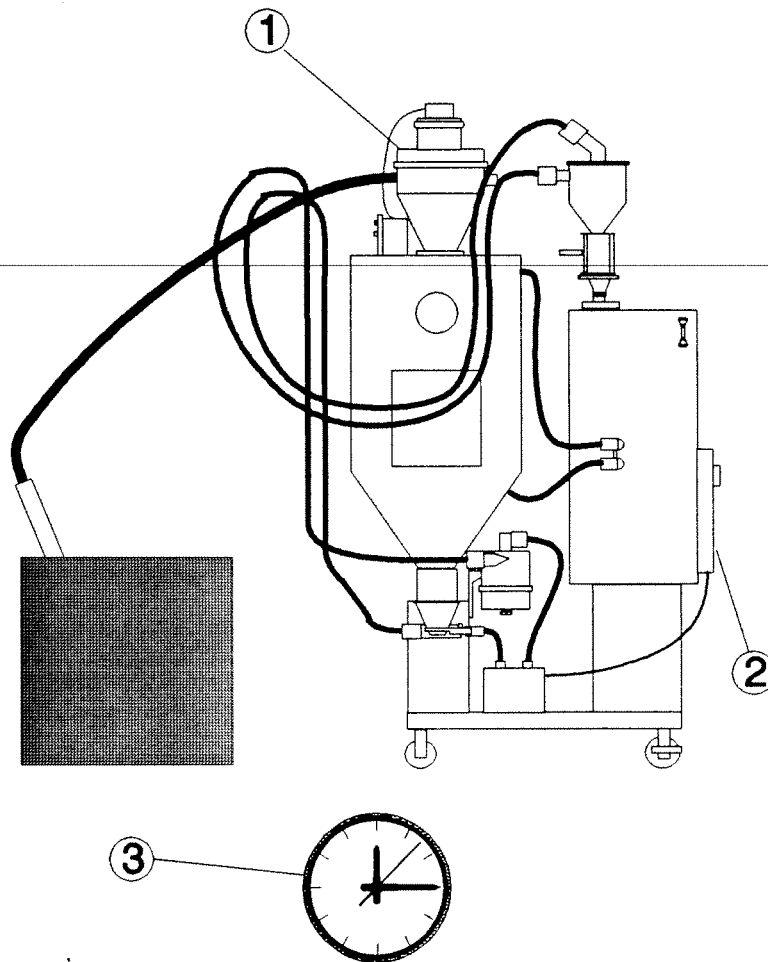

1. Load the hopper with plastic pellets, using either an integral loader or hand means.
2. Set the drying temperature and start the dryer. Refer to the **STARTING THE DRYER** procedure under the **CONTROL OPERATION** section of this manual for assistance.
3. Dry the material for the recommended residence specified for the plastic. Once the material has been dried for the recommended residence time, it may be transported to the molding machine for processing.

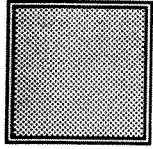

Moving the MDC30 Dryer

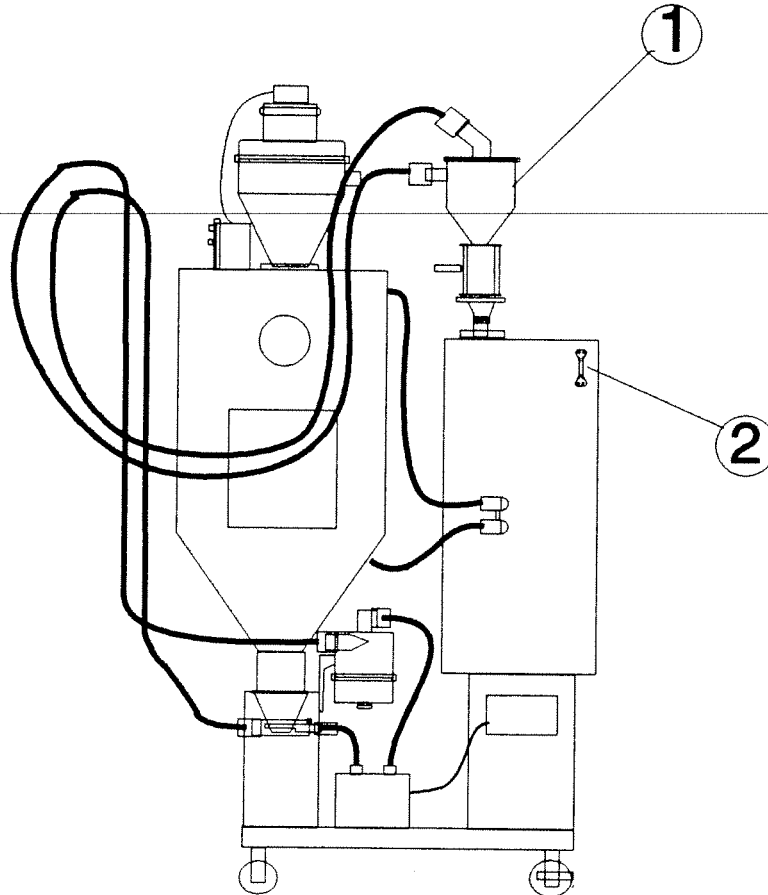

In order to transport the MDC dryer from the predrying area to the molding machine where the material can be processed:

1. Position the K-loader onto the transport bracket located on the dryer. Tighten the thumbscrew to secure the K-loader to the bracket.
2. Handles are located on the dryer to assist in transportation of the dryer.

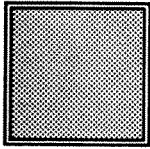

Conveying Operation

In order to convey material to the throat of the molding machine, there are five easy steps to follow.

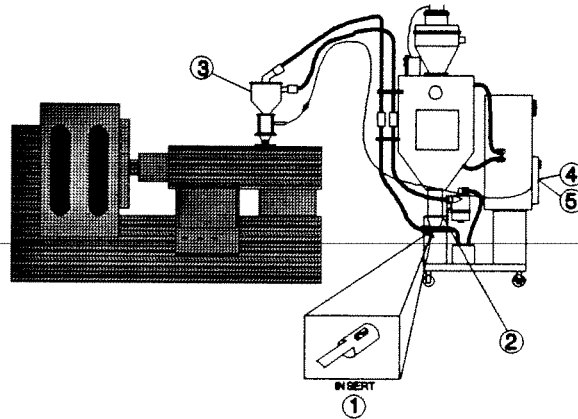

1. Two inserts are provided with the MDC dryer for conveying of virgin and regrind materials. One insert is for virgin pellet materials the other is for regrind materials. Ensure that the proper insert is placed inside the distribution box.
2. Open the slide gate at the bottom of the hopper to allow material to fill the distribution box.
3. Move the K-loader from the transportation bracket to the mounting bracket on the molding machine. Tighten the thumbscrew on the K-loader to secure it to the mounting bracket.
4. Press the "CONVEYING ON/OFF" button to start conveying to the molding machine. Please refer to the CONVEYING procedure under the CONTROL OPERATION section of this manual for assistance.
5. To continue drying the material, press the "RUN" button. Please refer to the STARTING THE DRYER procedure under the CONTROL OPERATION section of this manual for assistance.

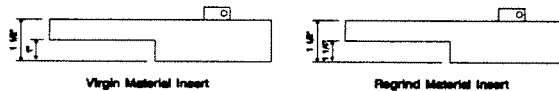

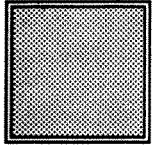

Filter Cleaning

A conveying dust collector is located on the MDC dryer frame and is used to filter the air used to convey the material. The frequency of cleaning this filter will depend on the type of material being processed.

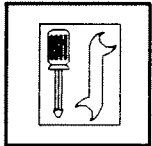

Tooling Requirements: None.

The conveying dust collector may be cleaned and inspected while either on the MDC frame or by removing and cleaning it at a remote location.

To remove the dust collector from the MDC frame:

1. With the conveying system off, use the quick disconnects on the conveying hoses, remove the two hoses from the conveying dust collector.
2. Lift the filter housing from its mounting bracket and clean as described below.

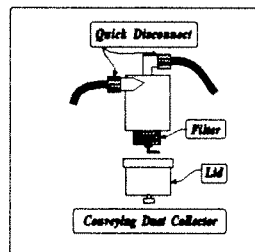

To clean the dust collector:

1. Remove the dust collector lid by loosening the self contained knob.
2. With the lid removed, empty all fines collected inside it.
3. Clean the inside of the filter housing being careful not to damage the conveying filter. A vacuum cleaner will work best in this situation.
4. If the conveying filter needs further cleaning, remove it by loosening the retaining nut.
5. By removing the filter from the housing, compressed air may be used to purge the filter of any remaining fines. Always blow from the inside out when using compressed air.
6. It is important to inspect the conveying filter for any holes or tears in the filter material. If any holes or tears exist, replace the filter cartridge with a new one before re-assembling the dust collector.

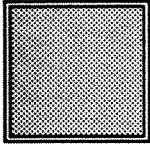

O-ring and Hose Inspection

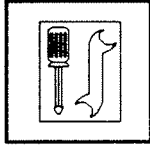

Tooling Requirements: None.

Inside all of the quick disconnect fittings are o-ring seals. It is important to periodically check the seals and hoses to ensure that dehumidified air is not leaking out and atmospheric air is not leaking into the drying system. Good seals are important to maintain consistent dewpoints when operating the dryer.

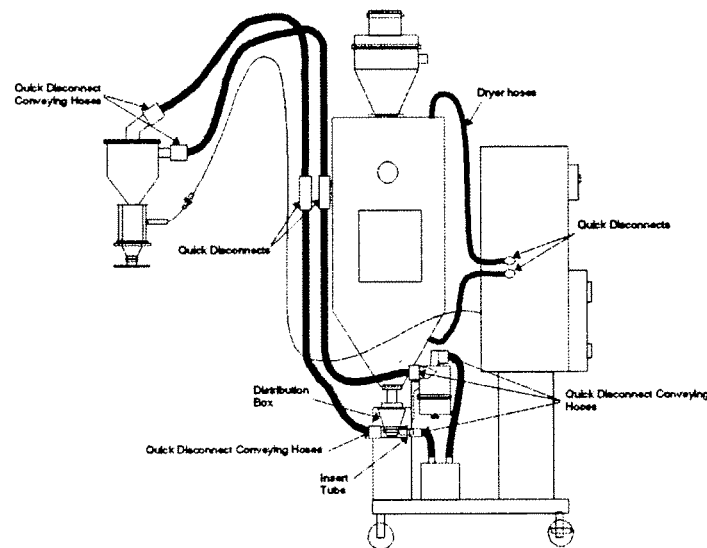

To check the o-ring seals and hoses:

1. Remove the quick disconnect coupling from any of the hoses located on the dryer.
2. The quick disconnect couplings are located on the K-loader, distribution box, conveying filter, process and return air dryer hoses, and material pickup tubes.
3. Visually inspect the o-ring seals and hoses for any cuts, holes, or cracks.
4. If a defect exists, remove and replace the bad hose or o-ring with a new one.

NOTE: For K-loader and CD30 Dryer maintenance items, refer to K-loader and CD30 Dryer manual supplied with your unit.

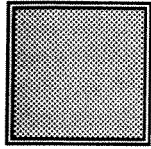

Hopper Draining and Cleaning

There are several ways to empty an MDC drying hopper.

1. Close the slide gate on the hopper. Disconnect the conveying hoses from the loader and the conveying blower. Remove the distribution box by undoing the clamps on the distribution box. Slide the distribution box out. Place a container under the hopper. Open the slide gate to start emptying the hopper.

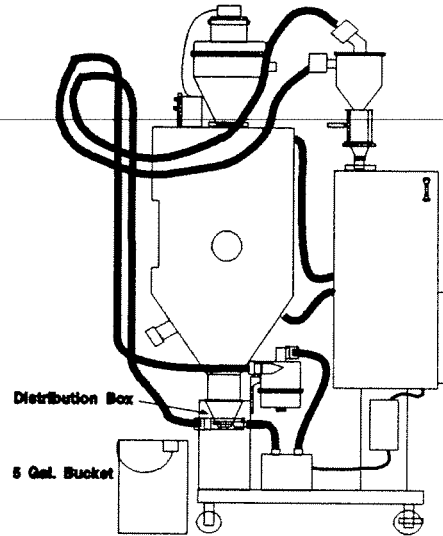

2. Place an adequate size drum under the material drain port of the hopper. Open the drain port valve (if this option is installed) and start emptying the hopper.

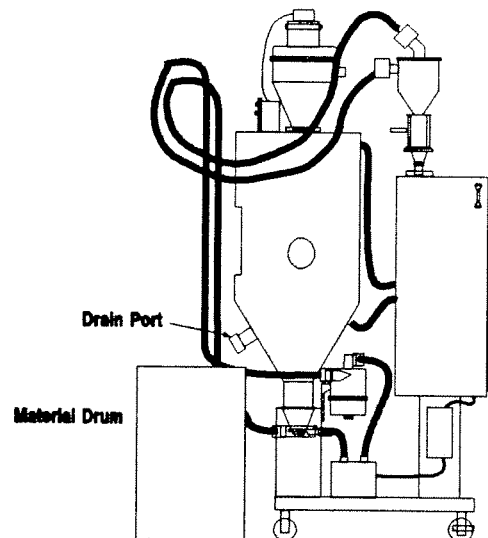

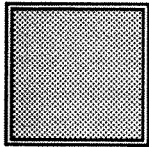

Hopper Draining and Cleaning

*3. Disconnect the material line from the K-loader by using the quick disconnect fitting provided. Place the disconnected hose inside a drum or gaylor. To empty the hopper, turn the conveying on by pressing the conveying ON/OFF button.

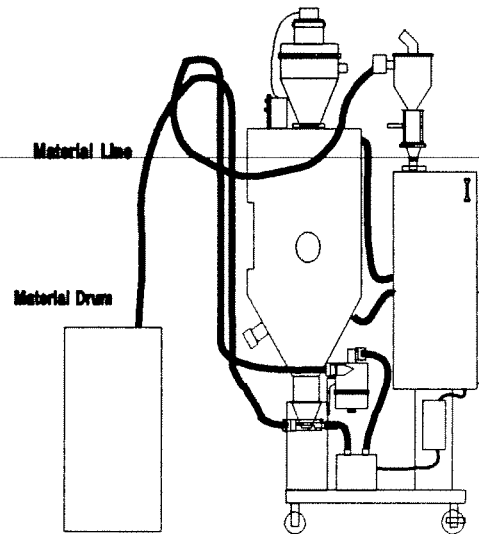

* This type of discharge is recommended when most of the material has been removed from the hopper.

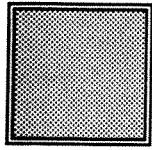

Troubleshooting

During operation should any malfunction occur, the "Alarm" LED will be energized, alerting the operator. By pressing the "Push to Read" button, the nature of the malfunction will be indicated in the setpoint display.

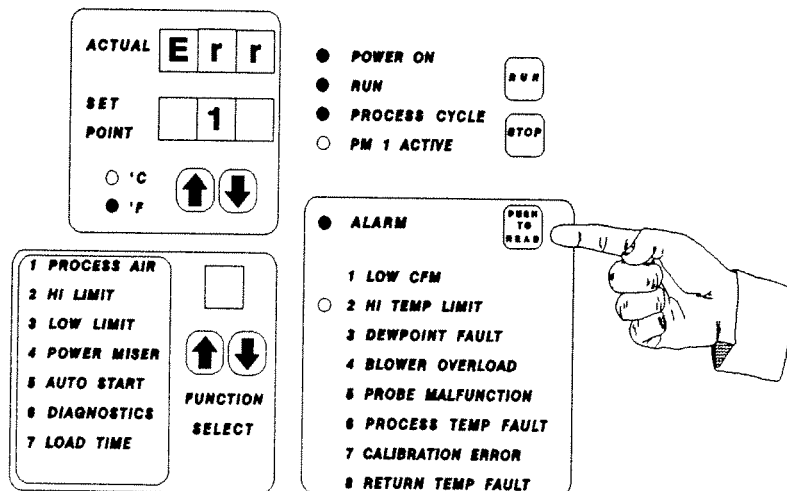

This indicates error message #1, which indicates Alarm #1 - Low CFM. Some alarms are passive, while others are shutdown alarms. (See the Troubleshooting guide section for a complete list of alarms and their meanings.)

NOTE: The display will stay energized for three seconds after the "Push to Read" button is pressed.

ALARM DISPLAY	MALFUNCTION	SOLUTION	AUTOMATIC SEQUENCE IF MALFUNCTION OCCURS
<p>ACTUAL E r r</p> <p>SET POINT 1</p> <p>°C °F</p> <p>← →</p>	<p>* LOW CFM</p> <ul style="list-style-type: none"> - Incorrect blower rotation. - Check valves may be clogged. 	<ul style="list-style-type: none"> - If blower rotates in the wrong direction, reverse any two leads at the main disconnect. - Check the valves, and replace if necessary. 	<ul style="list-style-type: none"> - Dryer shuts down and alarm light is energized.
<p>ACTUAL E r r</p> <p>SET POINT 2</p> <p>°C °F</p> <p>← →</p>	<p>* HI-TEMP LIMIT</p> <ul style="list-style-type: none"> - The high temperature limit has been exceeded during the process or regeneration cycle due to an abnormally high temperature in the heater box. - Faulty high temperature probe. 	<ul style="list-style-type: none"> - Check the heater box for signs of excessive heat. - Clear any restricted hoses. - Check for proper air flow in both circuits. - Check probe for obvious damage and replace if necessary. 	<ul style="list-style-type: none"> - Dryer shuts down and alarm light is energized.
<p>ACTUAL E r r</p> <p>SET POINT 3</p> <p>°C °F</p> <p>← →</p>	<p>DEWPOINT FAULT</p> <ul style="list-style-type: none"> - Dryer is not producing the proper dewpoint. - Desiccant may be contaminated. - System may be improperly installed. - Stuck check valve. 	<ul style="list-style-type: none"> - Check the valve and replace if necessary. - Consult Conair. 	<ul style="list-style-type: none"> - Alarm light is energized.
<p>ACTUAL E r r</p> <p>SET POINT 4</p> <p>°C °F</p> <p>← →</p>	<p>BLOWER OVERLOAD</p> <ul style="list-style-type: none"> - The overload on the blower has tripped. This could be caused by not having the overload properly adjusted, or the motor may be drawing excessive current. 	<ul style="list-style-type: none"> - Check the overload setting and adjust if necessary. - Reset the overload. - Check motor current against the name plate current to insure the motor is not drawing excessive amperage 	<ul style="list-style-type: none"> - Dryer shuts down and alarm light is energized.
<p>ACTUAL E r r</p> <p>SET POINT 5</p> <p>°C °F</p> <p>← →</p>	<p>* PROBE MALFUNCTION</p> <ul style="list-style-type: none"> - Either the temperature sensor has not been properly connected to the control box or the sensor is defective. 	<ul style="list-style-type: none"> - Check the connection. - Check the probe for obvious damage and replace if necessary. 	<ul style="list-style-type: none"> - Dryer shuts down and alarm light is energized.

ALARM DISPLAY	MALFUNCTION	SOLUTION	AUTOMATIC SEQUENCE IF MALFUNCTION OCCURS
<p>ACTUAL E r r</p> <p>SET POINT 6</p> <p>°C F</p> <p>↑ ↓</p>	<p>* PROCESS TEMP FAULT</p> <ul style="list-style-type: none"> - The process temperature is above or below an acceptable level. - The process temperature setting is too high for the dryer to maintain temperature at the set point. - Dryer may be too far from the hopper. - Air flow may be reversed. - Heaters may be defective. - Process temperature probe may not be properly positioned. - Supply voltage may be different than the name plate voltage. 	<ul style="list-style-type: none"> - Check heater amperage for defective heaters. - Check air flow direction. - Make sure the process temperature sensor is positioned at the inlet of the drying hopper. - Check supply voltage against name plate voltage. - Consult Conair for additional assistance. 	<ul style="list-style-type: none"> - Dryer shuts down and alarm light is energized.
<p>ACTUAL E r r</p> <p>SET POINT 7</p> <p>°C F</p> <p>↑ ↓</p>	<p>* CALIBRATION ERROR</p>	<ul style="list-style-type: none"> - Press PUSH TO READ to clear the error message. Press STOP, then turn the power off and back on. Press RUN to resume normal operation. - If you can't clear the error message after pressing PUSH TO READ, consult Conair. 	<ul style="list-style-type: none"> - Dryer shuts down and alarm light is energized.
<p>ACTUAL E r r</p> <p>SET POINT 8</p> <p>°C F</p> <p>↑ ↓</p>	<p>A - RETURN AIR TEMP UNSATISFACTORY</p> <ul style="list-style-type: none"> - Return air temperature is above 150° F. <p>B - RETURN AIR TEMP ABOVE LIMIT</p> <ul style="list-style-type: none"> - Return air temperature is above 180° F. 	<ul style="list-style-type: none"> - Insure hopper is full of material. - Add aftercooler if one is not already part of the system. - If aftercooler is present, check coils and clean if necessary. 	<ul style="list-style-type: none"> - Above 150° F, dryer alarm is energized. - Above 180° F, dryer shuts down and alarm light is energized.
<p>ACTUAL E r r</p> <p>SET POINT 9</p> <p>°C F</p> <p>↑ ↓</p>	<p>MATERIAL LEVEL TOO LOW</p> <ul style="list-style-type: none"> - The conveying filter may be clogged. - The conveying blower may be phased incorrectly. - Improper insert inside the distribution box. - Improper hose connections or air leaks in the hoses. - Demand sensor may need readjusted, or sensor may be faulty. 	<ul style="list-style-type: none"> - Check and clean the conveying filter. Replace the filter if it is torn or hopelessly clogged. - Check the blower rotation. If necessary, reverse any two leads at the main disconnect. - Make sure the proper material insert is inside the distribution box. - Check conveying hoses for proper connections, or any damage. Replace if necessary. - Check the demand sensor and replace if necessary. 	<ul style="list-style-type: none"> - Alarm light is energized.

ALARM DISPLAY	MALFUNCTION	SOLUTION	AUTOMATIC SEQUENCE IF MALFUNCTION OCCURS
<p>ACTUAL E r r</p> <p>SET POINT 1 0</p> <p>°C °F</p> <p>↑ ↓</p>	<p>* CHECKSUM ERROR</p> <ul style="list-style-type: none"> - Electronic noise - Calibration error 	<p>- Press PUSH TO READ to clear the error message, then press PUSH TO READ a second time to clear error message 7. Press STOP, then turn power off and back on. Press RUN to resume operation.</p>	<p>- Dryer shuts down and alarm light is energized.</p>
<p>ACTUAL E r r</p> <p>SET POINT 1 1</p> <p>°C °F</p> <p>↑ ↓</p>	<p>IMPROPER SHUT DOWN</p> <p>One of the following situations removed power to the dryer before it completed its cool-down cycle.</p> <ul style="list-style-type: none"> - Someone stopped the dryer incorrectly by pressing the power ON/OFF switch instead of the STOP key. - A shut down alarm. - A power outage. 	<p>- Always use the STOP key to shut down the dryer.</p> <ul style="list-style-type: none"> - Press PUSH TO READ to clear the error message, then press RUN to resume normal operation. - Press PUSH TO READ. If another error message appears, refer to the alarm code in this section to determine what shut down the dryer. - Check the dryer power supply. 	<p>- Alarm light is energized.</p>

① By pressing the "PUSH TO READ" key, the nature of the malfunction will be shown on the display.

* When this alarm condition exists, you will need to switch the dryer OFF to reset the unit. If the malfunction has been corrected, the it will exhibit normal conditions when restarted. If, however, the malfunction is not corrected, the unit will go into an alarm condition.

NOTE 1: For safety reasons, error #2 bypasses the microprocessor. If the error occurs, ERR 2 will not appear in the top display until the temperature has fallen below the trip point. During the this time, the red LED to the left of the "HI-LIMIT" message will be energized.

Conair has made the largest investment in customer support in the plastics industry. Our service experts are available to help with any problem you might have installing and operating your equipment. Your Conair sales representative also can help analyze the nature of your problem, assuring that it did not result from misapplication or improper use.

WE'RE HERE TO HELP

To contact Customer Service personnel, call:



HOW TO CONTACT CUSTOMER SERVICE

From outside the United States, call: 814-437-6861

You can commission Conair service personnel to provide on-site service by contacting the Customer Service Department. Standard rates include an on-site hourly rate, with a one-day minimum plus expenses.

If you do have a problem, please complete the following checklist before calling Conair:

- Make sure you have all model, serial and parts list numbers for your particular equipment. Service personnel will need this information to assist you.
- Make sure power is supplied to the equipment.
- Make sure that all connectors and wires within and between control systems and related components have been installed correctly.
- Check the troubleshooting guide of this manual for a solution.
- Thoroughly examine the instruction manual(s) for associated equipment, especially controls. Each manual may have its own troubleshooting guide to help you.
- Check that the equipment has been operated as described in this manual.
- Check accompanying schematic drawings for information on special considerations.

BEFORE YOU CALL ...

Additional manuals and prints for your Conair equipment may be ordered through the Customer Service or Parts Departments for a nominal fee.

EQUIPMENT GUARANTEE

Conair guarantees the machinery and equipment on this order, for a period as defined in the quotation from date of shipment, against defects in material and workmanship under the normal use and service for which it was recommended (except for parts that are typically replaced after normal usage, such as filters, liner plates, etc.). Conair's guarantee is limited to replacing, at our option, the part or parts determined by us to be defective after examination. The customer assumes the cost of transportation of the part or parts to and from the factory.

PERFORMANCE WARRANTY

Conair warrants that this equipment will perform at or above the ratings stated in specific quotations covering the equipment or as detailed in engineering specifications, provided the equipment is applied, installed, operated and maintained in the recommended manner as outlined in our quotation or specifications.

Should performance not meet warranted levels, Conair at its discretion will exercise one of the following options:

- Inspect the equipment and perform alterations or adjustments to satisfy performance claims. (Charges for such inspections and corrections will be waived unless failure to meet warranty is due to misapplication, improper installation, poor maintenance practices or improper operation.)
- Replace the original equipment with other Conair equipment that will meet original performance claims at no extra cost to the customer.
- Refund the invoiced cost to the customer. Credit is subject to prior notice by the customer at which time a Return Goods Authorization Number (RGA) will be issued by Conair's Service Department. Returned equipment must be well crated and in proper operating condition, including all parts. Returns must be prepaid.

Purchaser must notify Conair in writing of any claim and provide a customer receipt and other evidence that a claim is being made.

WARRANTY LIMITATIONS

Except for the Equipment Guarantee and Performance Warranty stated above, Conair disclaims all other warranties with respect to the equipment, express or implied, arising by operation of law, course of dealing, usage of trade or otherwise, including but not limited to the implied warranties of merchantability and fitness for a particular purpose.