

USER GUIDE  
UGE066-1009

# Scrap Saver

Models SSM-2, SSM-3 and SSM-5



Please record your equipment's model and serial number(s) and the date you received it in the spaces provided.

It's a good idea to record the model and serial number(s) of your equipment and the date you received it in the User Guide. Our service department uses this information, along with the manual number, to provide help for the specific equipment you installed.

Please keep this User Guide and all manuals, engineering prints and parts lists together for documentation of your equipment.

Date:

Manual Number: UGE066-1009

Serial Number(s):

Model Number(s):

**DISCLAIMER:** Conair shall not be liable for errors contained in this User Guide or for incidental, consequential damages in connection with the furnishing, performance or use of this information. Conair makes no warranty of any kind with regard to this information, including, but not limited to the implied warranties of merchantability and fitness for a particular purpose.

# Table of Contents

## 1-1 Introduction

Purpose of the user guide . . . . .	1-2
How the guide is organized . . . . .	1-2
Your responsibilities as a user . . . . .	1-3
ATTENTION: Read this so no one gets hurt . . . . .	1-4
How to use the lockout device . . . . .	1-5

## 2-1 Description

What is the ScrapSaver? . . . . .	2-2
Typical applications . . . . .	2-2
How it works . . . . .	2-4

## 3-1 Installation

Unpacking the boxes . . . . .	3-2
Preparing for installation . . . . .	3-2
Mounting the ScrapSaver onto the extruder throat . . . . .	3-3
Mounting the fluff cyclone (option) onto the ScrapSaver . . . . .	3-3
Mounting the ScrapSaver operator panel . . . . .	3-3
Connecting all field wiring . . . . .	3-4
Connecting the main power . . . . .	3-5
Testing the installation . . . . .	3-6
Linearization of the ScrapSaver machine to the extruder drive speed . . . . .	3-9
Checking for proper auger rotation . . . . .	3-10

## 4-1 Operation

ScrapSaver: Control Panel . . . . .	4-2
Menu area select function . . . . .	4-3
Speed control mode selection . . . . .	4-4
Current limit level selection . . . . .	4-5
Accel/Decel ramp selection . . . . .	4-6
Reload factory defaults function . . . . .	4-7
Roll feed enable speed setting . . . . .	4-8
System status screen . . . . .	4-9
Analog input level . . . . .	4-10
Drive I/O status . . . . .	4-11
Drive trip log . . . . .	4-12
Display active or logged alarms . . . . .	4-13
To start feeding film scrap . . . . .	4-14
To stop feeding film scrap . . . . .	4-14
Adjusting the roll feeder restart timer . . . . .	4-15

## 5-1 Maintenance

Preventative maintenance checklist . . . . .	5-2
Inspecting the gearbox oil level . . . . .	5-3
Cleaning the fluff hopper . . . . .	5-4
Draining the pellet hopper . . . . .	5-4

## 6-1 Troubleshooting

Before beginning . . . . .	6-2
A few words of caution . . . . .	6-3
<u>DIAGNOSTICS</u>	
How to identify the cause of a problem . . . . .	6-4
Alarms . . . . .	6-5
<u>REPAIR</u>	
Replacing fuses. . . . .	6-6
Replacing gearbox oil . . . . .	6-7
Adjusting the fluff high level switch. . . . .	6-8
Frequently asked questions. . . . .	6-9

## A Appendix

We're here to help . . . . .	A-1
How to contact customer service . . . . .	A-1
Before you call... . . . . .	A-1
Equipment guarantee . . . . .	A-2
Performance warranty . . . . .	A-2
Warranty limitations . . . . .	A-2



# Introduction

---

Purpose of the user guide. . . . . 1-2

How the guide is organized. . . . . 1-2

Your responsibilities as a user. . . . . 1-3

ATTENTION:

    Read this so no one gets hurt . . . . . 1-4

How to use the lockout device. . . . . 1-5

# Purpose of the User Guide

This User Guide describes the Conair ScrapSaver and explains step-by-step how to install, operate, maintain, and repair this equipment.

Before installing this product, please take a few moments to read the User Guide and review the diagrams and safety information in the instruction packet. You also should review manuals covering associated equipment in your system. This review won't take long, and it could save you valuable installation and operating time later.

# How the Guide is Organized

Symbols have been used to help organize the User Guide and call your attention to important information regarding safe installation and operation.



Symbols within triangles warn of conditions that could be hazardous to users or could damage equipment. Read and take precautions before proceeding.

- 1** Numbers indicate tasks or steps to be performed by the user.
- ◆ A diamond indicates the equipment's response to an action performed by the user.
- ☐ An open box marks items in a checklist.
- A circle marks items in a list.
- ◆♦ Indicates a tip. A tip is used to provide you with a suggestion that will help you with the maintenance and the operation of this equipment.
- 📎 Indicates a note. A note is used to provide additional information about the steps you are following throughout the manual.

## Your Responsibility as a User

You must be familiar with all safety procedures concerning installation, operation and maintenance of this equipment. Responsible safety procedures include:

- Thorough review of this User Guide, paying particular attention to hazard warnings, appendices and related diagrams.
- Thorough review of the equipment itself, with careful attention to voltage sources, intended use and warning labels.
- Thorough review of instruction manuals for associated equipment.
- Step-by-step adherence to instructions outlined in this User Guide.

## ATTENTION:

### Read this so no one gets hurt

We design equipment with the user's safety in mind. You can avoid the potential hazards identified on this machine by following the procedures outlined below and elsewhere in the User Guide.



**WARNING: Improper installation, operation, or servicing may result in equipment damage or personal injury.**

This equipment should be installed, adjusted, and serviced by qualified technical personnel who are familiar with the construction, operation, and potential hazards of this type of machine.

All wiring, disconnects, and fuses should be installed by qualified electrical technicians in accordance with electrical codes in your region. Always maintain a safe ground. Do not operate the equipment at power levels other than what is specified on the machine serial tag and data plate.



**WARNING: Voltage hazard**

This equipment is powered by three-phase alternating current, as specified on the machine serial tag and data plate.

A properly sized conductive ground wire from the incoming power supply must be connected to the chassis ground terminal inside the electrical enclosure. Improper grounding can result in severe personal injury and erratic machine operation.

Always disconnect and lock out the incoming main power source before opening the electrical enclosure or performing non-standard operating procedures, such as routine maintenance. Only qualified personnel should perform troubleshooting procedures that require access to the electrical enclosure while power is on.

## How to Use the Lockout Device

 **CAUTION:** Before performing maintenance or repairs on this product, you should disconnect and lockout electrical power sources to prevent injury from unexpected energization or start-up. A lockable device has been provided to isolate this product from potentially hazardous electricity.

Lockout is the preferred method of isolating machines or equipment from energy sources. Your Conair product is equipped with the lockout device pictured below. To use the lockout device:

- 1 Stop or turn off the equipment.**
- 2 Isolate the equipment from the electric power.** Turn the rotary disconnect switch to the OFF, or “O” position.
- 3 Secure the device with an assigned lock or tag.** Insert a lock or tag in the holes to prevent movement.
- 4 The equipment is now locked out.**

 **WARNING:** Before removing lockout devices and returning switches to the ON position, make sure that all personnel are clear of the machine, tools have been removed, and all safety guards reinstalled.

To restore power to the ScrapSaver, turn the rotary disconnect back to the ON position:

- 1 Remove the lock or tag.**
- 2 Turn the rotary disconnect switch to the ON or “I” position.**

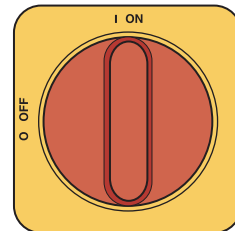
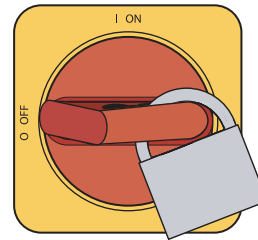
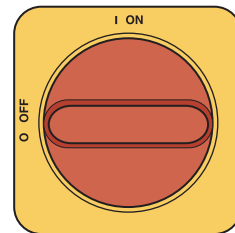



## Description

---

What is the ScrapSaver? . . . . . 2-2  
Typical applications . . . . . 2-2  
How it works . . . . . 2-4  
Specifications: ScrapSaver . . . . . 2-7

# What is the ScrapSaver machine?

The ScrapSaver machine is a voltage controlled vertical auger that meters ground film scrap material, either roll stock or trim, into the feed throat of an extruder. Blown and cast film extrusion production lines produce off-spec rolls and continuous edge or bleed trims during the production process. These materials, after reduction within a film scrap grinder, are metered back into the extrusion process directly above the main extruder feed throat using the vertical auger within the ScrapSaver machine.

## Typical Applications

**A** Automatic scrap reclaim system for recovery of trim scrap directly from a winder.

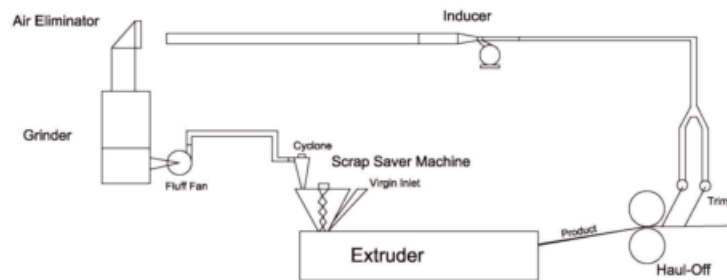

(continued)

# Typical Applications (continued)

**B** Automatic scrap reclaim system for recovery of trim scrap directly from a winder, and roll scrap from a grinder roll feeder intake.

Scrap Recovery System

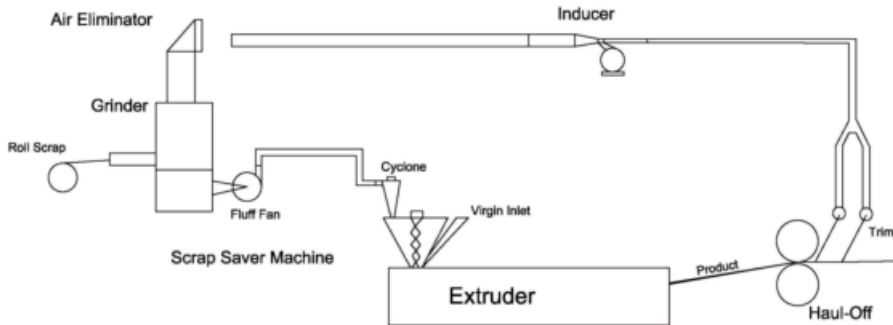

Description  
**2**

The ScrapSaver machine can be used successfully in reprocessing the following:

- Recovery of continuous edge and/or bleed trims
- Recovery of off-spec film roll-scrap
- Recovery of hand-fed loose scrap
- Typical refeeding rates are approximately 25% of extruder rate for ground scrap with bulk densities of 3 PCF (pounds per cubic foot) or greater. (Depending on extruder and process.)

## How It Works

The ScrapSaver machine meters the ground film scrap through a vertical auger, directly into the feed throat of an extruder. This ground scrap is deposited into the gravity fed main pellet stream of resin at a position low in the extruder feed section, directly above the extruder screw flights. The extruder screw takes the scrap and resin material from this feed section, into the extruder barrel for melt, pressurization and finally through the process die.

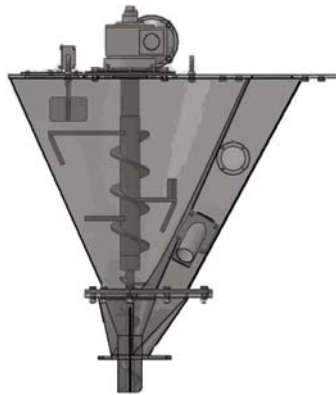

The vertical auger is designed to follow the speed of the extruder motor. That is, as the extruder screw RPM increases or decreases, the ScrapSaver vertical auger speed follows the extruder speed. This action allows the ScrapSaver vertical auger to maintain a constant scrap reclaim rate, relative to the production extrusion rate.

## How It Works (continued)

The machine is designed to accommodate 100% of the trim scrap (assuming it is less than 25% of extruder rate) and then make up the difference with roll scrap. A high level rotary switch, positioned within the scrap compartment of the ScrapSaver machine, is used to control the optional grinder roll-feeder, once the scrap chamber becomes full of ground scrap material; the roll feeder is turned off. Once the scrap level drops, the roll feeder is turned back on.

The motor controller for the ScrapSaver vertical auger will open a contact relay if the vertical auger speed slows below a minimum set-point. This relay contact will stop the optional grinder roll feeder, to prevent the roll scrap rate from exceeding the vertical auger feed rate.

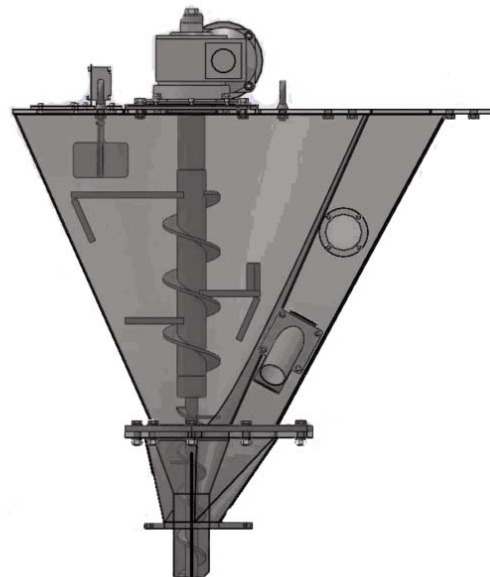

The motor controller for the ScrapSaver vertical auger, closes a contact relay if the current (amperage) for the vertical auger motor, exceeds the maximum motor current. This is useful to detect an overload condition of the fluff vertical auger motor. This contact can be tied to a customer supplied audible alarm. See the ScrapSaver electrical wiring schematic for this relay contact maximum voltage/current rating.



# Installation

---

Unpacking the boxes . . . . .	3-2
Preparing for installation . . . . .	3-2
Mounting the ScrapSaver onto the extruder throat . . . . .	3-3
Mounting the fluff cyclone (option) onto the ScrapSaver . . . . .	3-3
Mounting the ScrapSaver operator panel . . . .	3-3
Connecting all field wiring . . . . .	3-4
Connecting the main power . . . . .	3-5
Testing the installation . . . . .	3-6
Linearization of the ScrapSaver machine to the extruder drive speed . . . . .	3-9
Checking for proper auger rotation . . . . .	3-10

## Unpacking the Boxes

The ScrapSaver is attached to the pallet to prevent damage to the extended vertical auger. Care must be taken when removing this machine from the pallet, in order to avoid damage to the vertical auger extension. Installation personnel should only remove this machine from the pallet, once it is ready to be immediately placed upon the extruder throat, with the vertical auger extension inserted safely into the extruder feed throat.

## Preparing for Installation

The ScrapSaver machine and associated components are designed to be installed using specifically quoted convey distances and orientations. The installer is to make every effort to maintain the maximum or minimum convey distances and maximum number of elbows quoted for the trim and fluff convey lines. Failure to do so may compromise the quoted performance of the entire scrap reclaim system.

## Mounting the ScrapSaver onto the Extruder Throat

The ScrapSaver machine is specifically designed for each individual extruder. Critical dimensions include: the overall length of the auger extension, the diameter of the auger extension and the bolt pattern of the mounting flange.

The overall length of the auger extension should position the lowest point of the auger within 1.5 inches of the extruder screw feed flight, but not closer than 1 inch to the extruder feed flight. This dimension should be verified by the installer, before the ScrapSaver is mounted to the extruder feed throat.

## Mounting the Fluff Cyclone (Option) onto the ScrapSaver

The fluff cyclone attaches to the opening on the scrap chamber on top of the ScrapSaver machine. The cyclone inlet should be oriented toward the fluff material convey tube, routed from the grinder fluff material convey fan.

## Mounting the ScrapSaver Operator Panel

The operator panel for the ScrapSaver should be conveniently located for easy operator access. Wiring of the control panel should be completed by a qualified electrical contractor. The distance between the operator panel and the junction box mounted on the ScrapSaver should be minimized.

## Connecting all Field Wiring

Interconnection of the ScrapSaver control panel to the ScrapSaver junction box and optional roll-feeder interlock is very straightforward.

Two conduits are run from the control panel to the ScrapSaver J-box. One  $\frac{3}{4}$  inch diameter conduit with three 14 gauge conductors and one  $\frac{3}{4}$  inch conduit for the 4 conductor vector drive motor cable. The vector drive motor cable is a 14/4 shielded 660v VFD cable and is Conair part number 20504702.

Another  $\frac{1}{2}$  inch conduit is routed to the grinder roll feeder control panel. Two 14 gauge conductors are routed in this conduit to create a roll-feeder start/stop circuit.

One last  $\frac{3}{4}$  inch conduit is routed from the ScrapSaver control panel to the customer extruder drive cabinet and contains two 14 gauge conductors. These conductors supply the extruder drive speed reference voltage to the ScrapSaver control panel. This Signal Isolator is used as an interface to control the extruder motor speed in proportion to that of ScrapSaver auger motor. This Signal Isolator input signal may be taken from the voltage across the armature of the extruder motor (or preferably a smaller reference voltage proportional to the extruder drive speed), since the extruder speed will be proportional to this voltage. To follow the extruder speed voltage signal, wire the positive side of the extruder speed voltage to Terminal 6 (if 0-20 VDC range), to Terminal 7 (if 0-120 VDC range) or to Terminal 8 (if 0-550 VDC range). Be sure to conduct the adjustment of the Signal Isolator board shown in the section “Linearization of ScrapSaver to the extruder drive speed” referenced below.

For exact terminal numbers and wire termination information, refer to the ScrapSaver control panel and junction box interconnection schematics.

# Connecting the Main Power



**CAUTION:** Always disconnect and lock out the main power sources before making electrical connections. Electrical connections should be made only by qualified personnel.

The main power is connected to the ScrapSaver control panel using a 3-phase AC service, with ground. These wires are terminated directly to the line side of the ScrapSaver control panel main disconnect. Refer to the ScrapSaver control panel schematic for voltage and amperage supply requirements.



**IMPORTANT:** Always refer to the wiring diagrams that came with your equipment before making electrical connections.

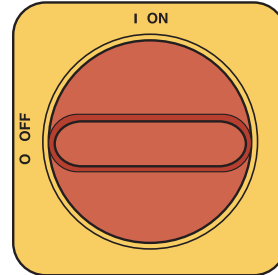

# Testing the Installation

Once all the interconnections, electrical and mechanical, are completed, the system test is ready to begin. This section describes the functional test of the ScrapSaver high level switch, the ScrapSaver emergency interlocks, the ScrapSaver vertical auger speed control, and lastly the optional roll-feeder start/stop control circuit.

**To test the high level switch:**

- 1** Be sure the E-stop button is pressed and the power is removed from the ScrapSaver panel. Open the front door of the ScrapSaver electrical control panel.
- 2** Place an ohmmeter across terminal numbers 1 and 2 in the ScrapSaver control panel.
- 3** The ScrapSaver high level switch is located inside the ScrapSaver machine. To test this switch, the fluff chamber access door on top of the ScrapSaver machine must be opened. Open the door, and deflect the high level paddle switch.
- 4** Read the ohmmeter and ensure the ohm value is shown to be open with the paddle deflected.
- 5** Release the paddle and ensure the ohm value is shown to be zero with the paddle released.
- 6** Remove the ohmmeter from across terminal numbers 1 and 2 in the ScrapSaver control panel.
- 7** Close and secure the fluff chamber access door on top of the ScrapSaver machine.
- 8** Close the front door of the ScrapSaver electrical control panel, apply power to the panel and turn ON the power disconnect.

## Testing the Installation (continued)

To test the emergency stop button:

- 1** Ensure the emergency stop button on the ScrapSaver control panel, as well as the emergency button on the ScrapSaver machine junction box, are pulled into the on position.
- 2** Apply the 3 phase power to the ScrapSaver electrical panel.
- 3** Press the start button on the ScrapSaver control panel.
- 4** The start button should illuminate green, and the ScrapSaver touch screen should be powered on

## Testing the Installation (continued)

To test the emergency stop circuit:

- 1 Test the emergency stop circuit. Press the E-stop button on the ScrapSaver control panel.** The illuminated start button and the touch screen should both turn off.
- 2 Test the emergency stop circuit. Pull out the emergency stop button and press the start button on the ScrapSaver control panel.** The start button should illuminate green, and the ScrapSaver touch screen should be powered on.
- 3 Press the E-stop button on the ScrapSaver machine junction box.** The illuminated start button and the touch screen should both turn off.
- 4 Pull out the emergency stop button on the ScrapSaver junction box. Press the start button on the ScrapSaver control panel.** The start button should illuminate green, and the ScrapSaver touch screen should be powered on.

# Linearization of the ScrapSaver Machine to the Extruder Drive Speed

Refer to the ScrapSaver control panel electrical schematic for the following procedure. All measurements and adjustments in this section are on the signal isolator board, located within the ScrapSaver electrical control cabinet.

Voltage signal follower calibration of the signal isolator board: During this test the ScrapSaver vertical auger will not rotate. This part of the procedure ensures the DC signal from the extruder drive is properly linearized to the signal isolator card installed inside the ScrapSaver control panel.

On the signal isolator card inside the ScrapSaver control panel, ensure the VOLTAGE/CURRENT selector switch is set to the VOLTAGE position.

Confirm that the positive DC voltage input lead from the extruder DC speed reference is connected to the appropriate terminal (refer to schematic)

- 1 Apply the maximum DC voltage input signal from the extruder drive.**
- 2 Adjust MAXIMUM OUTPUT trimmer pot to achieve the desired maximum output voltage of 10 vdc across Terminals 9 and 10**, which normally is equal to or less than the control extruder reference voltage, depending upon whether the ScrapSaver motor is to run at its rated speed or at a slower speed with maximum DC input voltage to the signal insulator board.
- 3 Apply the minimum DC voltage input signal from the extruder drive** (usually 10% of the extruder maximum speed).
- 4 Adjust MINIMUM OUTPUT trimmer pot to achieve the desired minimum output voltage across Terminals 9 and 10** (usually 0VDC). This is used to achieve the desired minimum speed of the ScrapSaver motor.
- 5 Repeat steps 1 through 4 until the signal isolator board is properly adjusted for the designed maximum and minimum output DC voltages across terminals 9 and 10.**

# Checking for Proper Auger Rotation

The proper rotation of the ScrapSaver auger is clockwise, when viewed from the top of the gearbox. This section details the procedure to test the rotation.

- 1 Apply a midrange DC voltage input signal from the extruder drive.** This can be done by setting a DC input voltage as described in step 1 of the Linearization of ScrapSaver to the extruder drive speed section above, or alternatively, by setting a midrange speed on the extruder drive itself.
- 2 On the ScrapSaver control panel touch screen, scroll the set speed bar to a midpoint setting.** (Scroll the set speed bar toward the right).
- 3 Observe the rotation of the auger shaft at the gearbox, viewed above the ScrapSaver machine.** The rotation should be clockwise.
- 4 If the rotation is counter-clockwise, stop the auger motor, remove all the AC power from the control panel, and swap two of the main AC feed wires to the ScrapSaver control panel.** Re-apply the AC voltage and repeat steps 1 to 3.
- 5 On the ScrapSaver control panel touch screen, scroll the set speed bar to a lowest point setting.** (Scroll the set speed bar completely toward the left).
- 6 Remove the DC input signal from the extruder drive by setting the value to zero VDC or set the extruder speed to zero rpm.** The ScrapSaver vertical auger should stop rotation.

## Operation

---

ScrapSaver: Control Panel . . . . .	4-2
Menu area select function . . . . .	4-3
Speed control mode selection . . . . .	4-4
Current limit level selection . . . . .	4-5
Accel/Decel ramp selection . . . . .	4-6
Reload factory defaults function . . . . .	4-7
Roll feed enable speed setting . . . . .	4-8
System status screen . . . . .	4-9
Analog input level . . . . .	4-10
Drive I/O status . . . . .	4-11
Drive trip log . . . . .	4-12
Display active or logged alarms . . . . .	4-13
To start feeding film scrap . . . . .	4-14
To stop feeding film scrap . . . . .	4-14
Adjusting the roll feeder restart timer . . . . .	4-15

# ScrapSaver: Control Panel

**Load Display Dial**  
The LOAD display dial indicates the amperage load being placed onto the AC vector drive motor that rotates the vertical scrap auger. The load is shown as a percentage of full load amps, and ranges from 0 to 100%. This percentage value is displayed directly below the LOAD display dial.

**Indicator**  
The red dot between the Load and Speed indicators the roll feeder on the grinder is not enabled to run. This dot turns green if the roll feeder is enabled to run, indicating the fluff chamber of the Scrap Saver machine is below the full level.

**Speed Display Dial**  
The SPEED display dial indicates the percent speed of the AC vector drive motor that rotates the vertical scrap auger. The speed is shown in percent the AC motor and ranges from 0 to 100%. This percent speed value is displayed directly below the SPEED display dial.

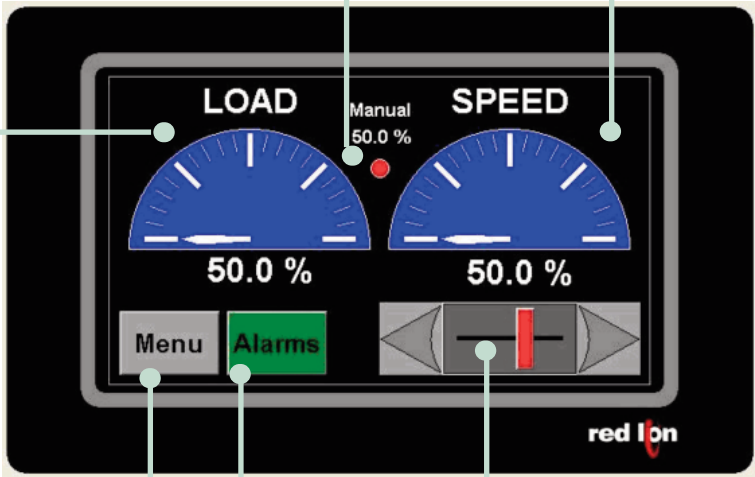

**Menu Button**  
The MENU key is pressed to access and configure the ScrapSaver machine MODE, LIMITS, RAMP and DEFAULT features. Each of these features is described on the following pages.

**Alarms Button**  
The ALARMS key is pressed to access the operational alarms for the ScrapSaver machine.

**Indicator**  
The red bar beneath the Speed indicator dial is adjusted left or right using the adjacent arrow keys < >. Pressing the left arrow key decreases the AC motor speed. Pressing the right arrow key increases the AC motor speed.

# Menu Area Select Function

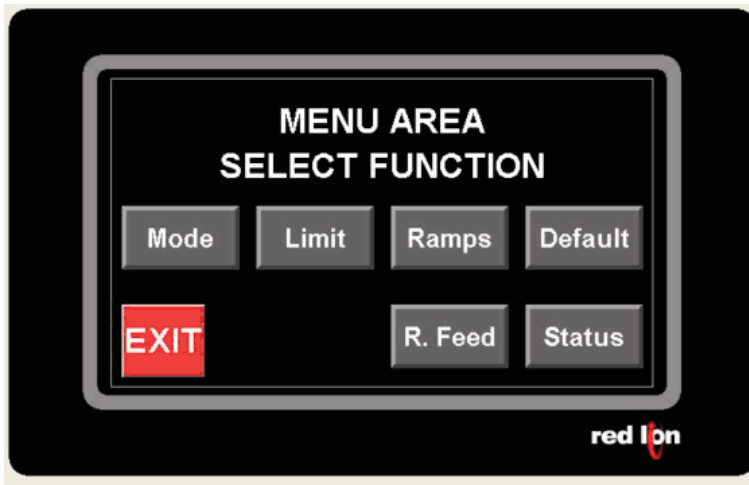

Pressing the MENU button on the main operator screen allows access to all the system features shown above.

## Speed Control Mode Selection



The MODE selection button allows the selection of either AUTO operation or MANUAL operation of the vertical auger AC motor.

The selection of AUTO operational mode forces the AC motor to follow the speed of the extruder positioned below the scrap saver. When the extruder speed increases, the ScrapSaver AC motor rpm increases. When the extruder speed decreases, the ScrapSaver AC motor rpm decreases. Using this mode requires the operator to manually set an RPM speed setting to accommodate the normal production speed by adjusting the left or right arrow keys < > on the MAIN operator screen. Pressing the left arrow key decreases the AC motor rpm. Pressing the right arrow key increases the AC motor rpm. Again, once configured, the motor rpm of the ScrapSaver will follow the extruder screw speed rpm.

The selection of MANUAL operational mode forces the AC motor to ignore the speed of the extruder positioned below the ScrapSaver. Using this mode only requires the operator to set an RPM speed setting by adjusting the left or right arrow keys < > on the MAIN operator screen. Pressing the left arrow key decreases the AC motor rpm. Pressing the right arrow key increases the AC motor rpm. Again, the rpm of the ScrapSaver auger will not follow an extruder screw speed. This mode should only be used for troubleshooting or testing purposes, since it is possible to operate the ScrapSaver motor even if the extruder is stopped.

# Current Limit Level Selection

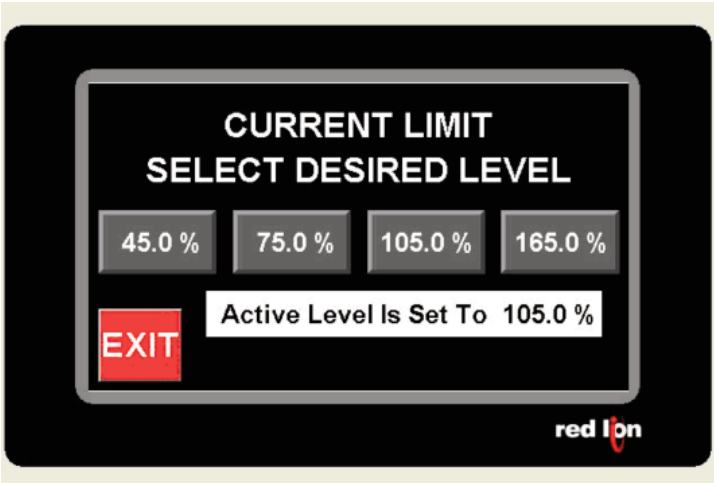

The current LIMIT of the ScrapSaver AC motor is set here. A choice of four values allows the ScrapSaver machine to act conservatively or aggressively when metering scrap material into the throat of the extruder. Once set, these values are used to prevent material cramming and motor overload and will trigger an alarm output if the current limit value is exceeded. This will be displayed in the ALARMS feature that monitors the active amperage of the ScrapSaver AC motor. In theory when the current limit is reached, the auger will slow down and stop until material exits and then it will resume to the set SPEED.

## Accel/Decel Ramp Selection

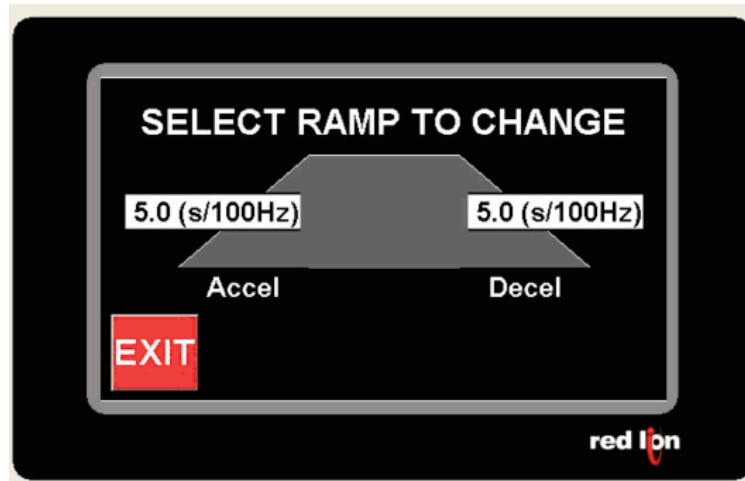

The RAMP setting of the ScrapSaver AC motor allows the acceleration and deceleration setting of the motor to be more or less responsive to the operator SPEED setting.

# Reload Factory Defaults Function

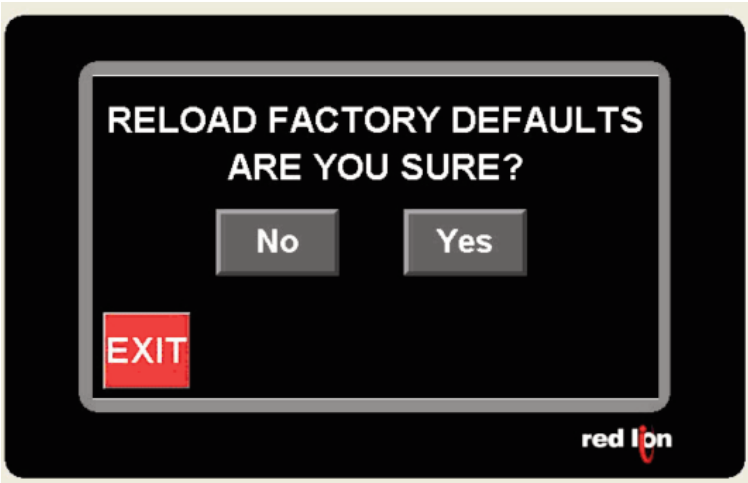

The DEFAULT key allows for the ScrapSaver AC drive system to be reset to the factory default settings. The default settings are shown on each of the screen pages depicted in this manual.

## Roll Feed Enable Speed Setting

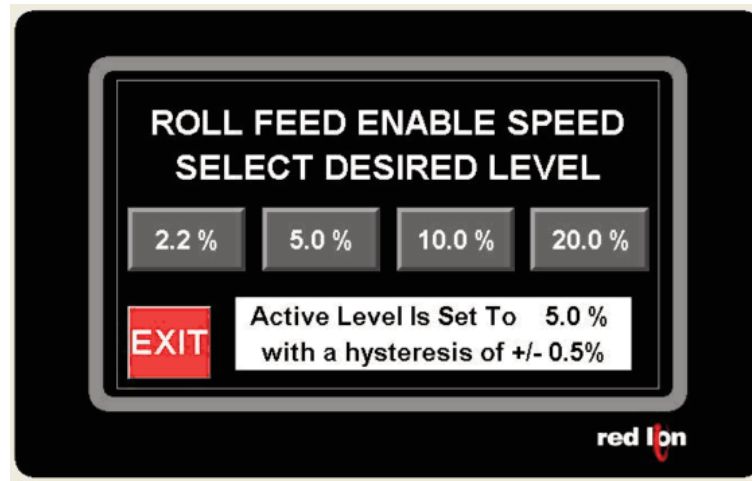

The roll feed enable speed setting is set to equal the Scrap Saver auger speed, which when above the selected speed, will allow the roll feeder on the grinder to pull roll scrap into the grinder.

# System Status Screen

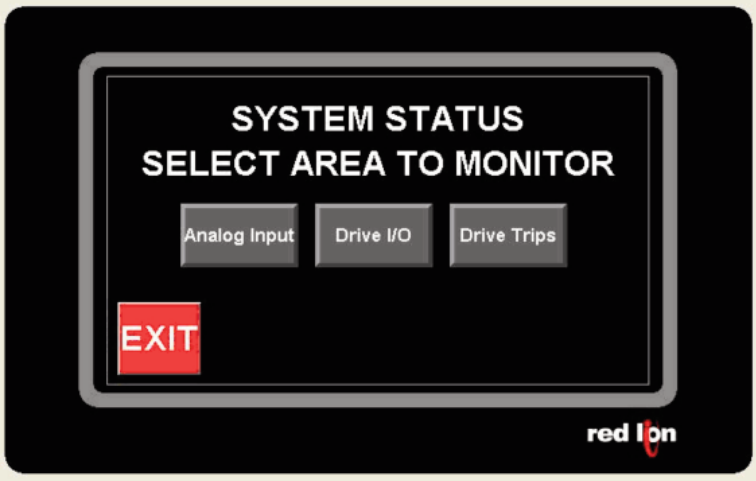

The System Status screen provides access to additional screens for monitoring the analog voltage from the extruder which the Scrap Saver speed is slaved to follow, the drive I/O inputs and outputs status, and finally the trip status (faults) of the Scrap Saver drive system itself. Each of these screens is described in more detail on the following pages.

## Analog Input Level

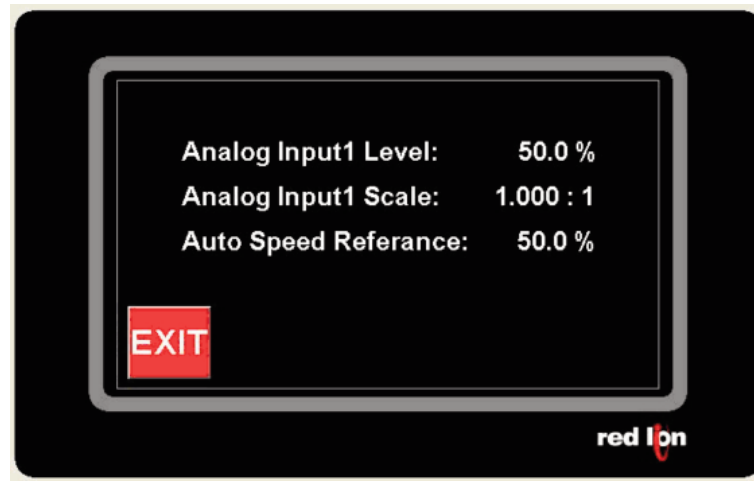

The Analog Input Level refers to the DC Voltage value present on terminals T1 and T2 of the Scrap Saver AC drive controller. This is a value from 0 to 10 VDC. For example, 50% displayed here, indicates the voltage value should be 5 VDC.

The Analog Input Scale allows the user to change (scale) the value received on terminals T1 and T2 internally to the Scrap Saver AC drive controller. For example, setting this scale value to 0.5 : 1 would change the DC voltage seen internally to the drive controller to one-half the normally seen voltage range of 0-10VDC. The normal setting for this is 1:1.

The Auto Speed Reference value is equal to the Analog Input Level value multiplied by the Auger Speed setting, set by the operator from the Main Screen on the Scrap Saver control panel.

## Drive I/O Status

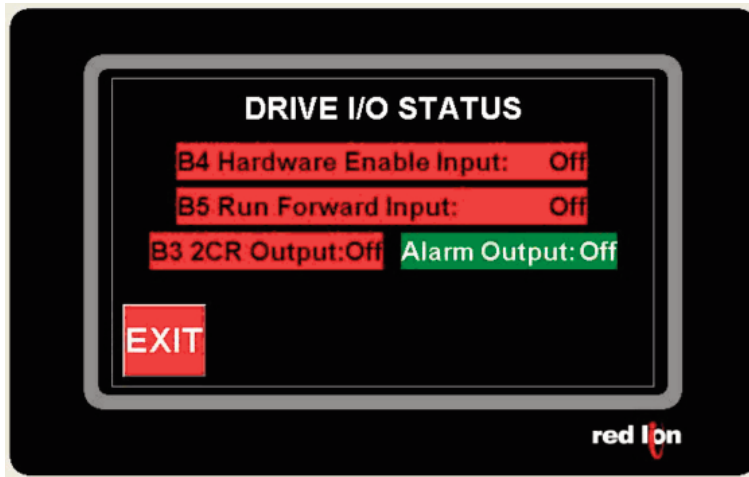

The B4 Hardware Enable Input displays OFF if the Stop button is pressed, and ON if the Start button is pressed.

The B5 Run Forward Input displays OFF if the Stop button is pressed, and ON if the Start button is pressed.

The B3 2CR Output indicates if the Alarm output at T5 T6 on the Scrap Saver AC drive controller is ON(closed) or OFF(open).

## Drive Trip Log

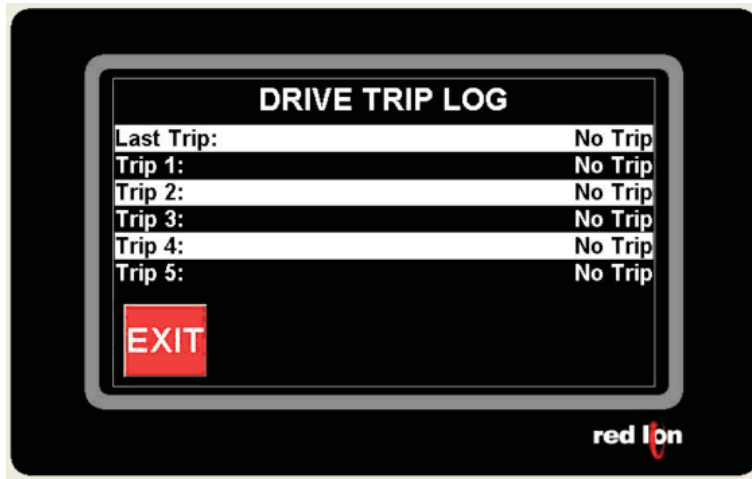

The Drive Trip Log display a log of each time the Scrap Saver AC drive controller was tripped off. The AC drive controller can be tripped off by an over current condition.

## Display Active or Logged Alarms

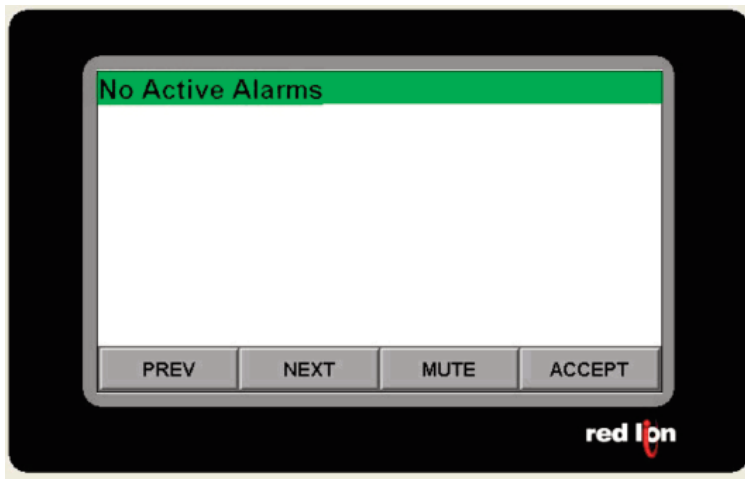

The ALARM key allows the operator to view, silence and acknowledge ScrapSaver machine alarms. Possible alarms for the system include:

Communications Loss – indicates the communication link between the touch screen and the ScrapSaver AC drive has failed.

Drive Fault – indicates the AC vector drive has faulted. Clearing this alarm will clear and reset the drive for normal operation.

Current Limit – indicates the SPEED setting by the operator is too high and is creating an amperage over current condition of the AC motor. This means the current limit has been reached. The limit has 4 level settings through the Current Limit Level setting. Solutions include decreasing the set SPEED or raising the Current Limit setting level.

Over Load – indicates the SPEED setting by the operator is too high and has resulted in an amperage overload condition of the AC motor.

Drive Over Temp – this indicates the heat sink on the drive has exceeded 95C. The most likely cause for this is an excessive ambient temperature surrounding the motor.

## To Start Feeding Film Scrap

Scrap material introduced into the ScrapSaver machine originates from two possible sources. The first is from the film winder on the production extrusion line. This scrap is commonly referred to as edge trims or bleed trims. The trims are conveyed into the trim removal inducer fan and conveyed to the granulator. These trims can be introduced into the system at any time after the ScrapSaver machine SPEED has been set.

The second source of scrap material originates from an optional roll feeder, attached to the production line film granulator. This roll scrap can be introduced into the roll feeder at any time after the ScrapSaver machine SPEED has been set.

As the ground scrap material is introduced into the ScrapSaver machine, the operator can adjust the SPEED setting of the ScrapSaver AC motor, to efficiently feed the scrap into the extruder throat. The LOAD dial must be monitored during this initial introduction of scrap, to ensure the ScrapSaver AC motor is not overloaded, usually due to a speed setting that is too high. In general, the ScrapSaver AC auger motor must be running quickly enough to meter the scrap into the extruder, but not so quickly, that it overloads the motor, or any extrusion process capability.

## To Stop Feeding Film Scrap

To stop feeding film scrap, the operator must first eliminate the introduction of edge trims into the trim scrap removal inducer unit, as well as the optional roll feeder on the granulator. After such time, the SPEED setting on the ScrapSaver control panel can be set to zero.

# Adjusting the Roll Feeder Restart Timer

Located inside the ScrapSaver electrical control panel is timer TD1. This timer is used to delay the restarting of the granulator roll feeder, after the high level switch inside the ScrapSaver fluff chamber has been tripped (indicating a full condition of the fluff chamber). Once this high level switch becomes uncovered, the roll feeder will automatically start AFTER the TD1 time has counted down completely.

Setting this timer value too low will cause the roll feeder to cycle on and off quickly. In general, a time setting of about 10 seconds is sufficient, but may be set lower if the fluff chamber empties completely before the roll feeder comes back on.

Allowing the fluff chamber to run empty, if roll scrap is being introduced, will increase the production time needed to recover all the roll scrap back into the process. Additionally, if the scrap level inside the ScrapSaver fluff compartment is allowed to become repeatedly full, and then empty, some instability of the extrusion process may occur.



# Maintenance

---

Preventative maintenance checklist . . . . . 5-2  
Inspecting the gearbox oil level . . . . . 5-3  
Cleaning the fluff hopper . . . . . 5-4  
Draining the pellet hopper . . . . . 5-4

# Preventative Maintenance Checklist

Routine maintenance will ensure optimum operation and performance of the ScrapSaver. We recommend the following maintenance schedule and tasks.

Thereafter, oil should be changed at least every 2500 operating hours (5000 for synthetic oil lubricant) or every 6 months (12 months for synthetic lubricant), whichever occurs first.

Refill with .88 pints of Hub City gear lubricant GL-460 (#8580001024) or Hub City Synthetic (#8580001011).

- **After the first 100 hours of operation**

- Drain out the initial oil.**

- Flush out the worm gear case with an approved non-flammable, non-toxic solvent** {such as Lubriplate Syn Flush, Lubriplate Pure Flush Whitmore's Flushing oil (#06802030) or Medallion Flushing Oil Kosher (#06812010)}, **and refill.**

- **Every 2500 operating hours** (5000 for synthetic oil lubricant) **or every 6 months** (12 months for synthetic lubricant), **whichever occurs first.**

- Refill with .88 pints of Hub City gear lubricant GL-460 (#8580001024) or Hug City Synthetic (#8580001011).**

# Inspecting the Gearbox Oil Level

- 1 Remove Fill and Breather Plug 1, figure W11, and Oil Level Plug 2, figure W11.**
- 2 Fill gearbox with recommended lubricant to a level near the centerline of the uppermost horizontal shaft or until lubricant starts coming out Oil Level Plug 2, figure W11.**

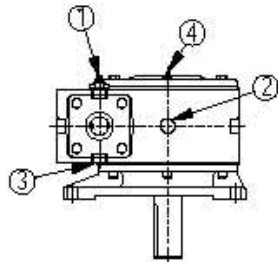

Figure W11:Output Vertical Down

Since the gearbox is positioned with the output vertically down, an adequate amount of lubrication must be supplied to the Bearing through grease fitting 4, figure W11, as indicated above.

## **Cleaning the Fluff Hopper**

To accomplish a product changeover, it may become necessary to access and clean the interior of the ScrapSaver fluff hopper compartment. To clean this compartment, an access door is positioned on top of the ScrapSaver machine. This access door, when opened, will allow an operator to clean the compartment, using compressed air or some alternate yet suitable method.

## **Draining the Pellet Hopper**

To accomplish a product changeover, it may become necessary to drain the pellet hopper compartment. To clean this compartment, a drain port is positioned near the bottom of ScrapSaver machine. This drain port, when opened, will allow an operator to drain and clean the compartment, using compressed air or some alternate yet suitable method.

# Troubleshooting

---

Before beginning . . . . .	6-2
A few words of caution . . . . .	6-3
<u>DIAGNOSTICS</u>	
How to identify the cause of a problem . . . . .	6-4
Alarms . . . . .	6-5
<u>REPAIR</u>	
Replacing fuses . . . . .	6-6
Replacing gearbox oil . . . . .	6-7
Adjusting the fluff high level switch . . . . .	6-8
Frequently asked questions . . . . .	6-9

## Before Beginning

You can avoid most problems by following the recommended installation and maintenance procedures outlined in this User Guide. If you do have a problem, this section will help you determine what caused it and how to fix it.

- ❑ **Find the wiring and equipment diagrams that were shipped with your equipment.** These diagrams are the best reference for correcting a problem. The diagrams also will note any custom features, such as special wiring or alarm capabilities, not covered in this User Guide.
- ❑ Verify that you have all instructional materials related to the ScrapSaver, its control systems and its components. Additional details about troubleshooting and repairing specific components are in these manuals.
- ❑ Verify that you have manuals for equipment located upstream and downstream from the ScrapSaver. Solving problems related to material conveyed to the ScrapSaver or to extrusion quality may require troubleshooting malfunctions or incorrect operating procedures on other pieces of equipment on the extrusion line.

## A Few Words of Caution



**WARNING:** This machine should be adjusted and serviced only by qualified technical personnel who are familiar with the construction and operation of this type of equipment.



**WARNING:** Always disconnect and lock out the main power supply before opening the ScrapSaver electrical enclosure.

Troubleshooting procedures that require access to the electrical enclosure while the power is on should be performed only by qualified electrical technicians who know how to use electrical testing equipment and understand the hazards involved.

**CAUTION:** Hot surfaces. Always protect yourself from hot surfaces inside and outside of the dryer and hopper.

## How to Identify the Cause of a Problem

To find the cause of an alarm, go to the Main Menu and press the ALARMS key. The cause of the alarm and the time that it occurred will be displayed on the screen. The user can navigate the alarm list using the Prev and Next keys. The accept key when pressed acts to acknowledge the alarm. The Mute key acts to silence the alarm output relay.

# Alarms

The ALARM key allows the operator to view, silence and acknowledge ScrapSaver machine alarms. Possible alarms for the system include:

Alarm	Possible cause	Solution
Communications Loss	The communication link between the touch screen and the ScrapSaver AC drive has failed.	Check all cables and wires. Restart the equipment.
Drive Fault	The AC vector drive has faulted.	Clearing this alarm will clear and reset the drive for normal operation.
Current Limit	The SPEED setting by the operator is too high and has created an amperage over current condition of the AC motor. This means the current limit has been reached. The limit has 4 level settings through the current limit level setting.	Solutions include decreasing the set SPEED or raising the current limit setting level.
Over Load	The SPEED setting by the operator is too high and has resulted in an amperage overload condition of the AC motor.	Reduce the speed setting. Reset the equipment.
Drive Over Temp	Indicates the heat sink on the drive has exceeded 95°C. The most likely cause for this is an excessive ambient temperature surrounding the motor.	Allow the equipment to cool.

# Replacing Fuses

This procedure covers the factory-installed fuses inside the ScrapSaver electrical control panel. If you have installed an electrical disconnect or emergency stop switch, additional fuses and/or breakers may have been used elsewhere in the main power circuit.

Located inside the ScrapSaver electrical control panel are fuses for the AC line, 1FU, the power transformer primary side, 2FU and the power transformer secondary side, 3FU.

To replace a blown fuse:

- 1 Disconnect and lockout the main power supply.**
- 2 Open the electrical enclosure door. Turn the screws on the front panel counterclockwise to open.**
- 3 Replace the fuse.** The fuses are located inside the control cabinet and are labeled and identified on the subpanel and the electrical print.
- 4 Close the electrical enclosure and restart the unit.**

# Replacing Gearbox Oil

Refill with .88 pints of Hub City gear lubricant GL-460 (#8580001024) or Hub City Synthetic (#8580001011).

- 1** Remove Fill and Breather Plug 1, figure 11, and Oil Level Plug 2, figure 11.
- 2** Fill the gearbox with recommended lubricant to a level near the centerline of the uppermost horizontal shaft or until lubricant starts coming out Oil Level Plug 2, figure 11.

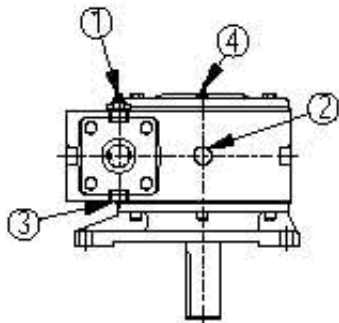

Figure W11:Output Vertical Down

- 3** Since the gearbox is positioned with the output vertically down, an adequate amount of lubrication must be supplied to the Bearing through grease fitting 4, figure W11, as indicated above.

## Adjusting the Fluff High Level Switch

To adjust the fluff high level switch, it will be necessary to access the interior of the ScrapSaver fluff hopper compartment. To open this compartment, remove the fastener used to hold the fluff door closed, located on the top of the ScrapSaver machine.

The fluff level switch mechanical arm should be positioned to properly make contact with the scrap material. Deflecting the mechanical arm should produce a slight click of the electrical contact switch attached to the mechanical arm.

For electrical testing of this switch, refer to Section 3, testing the installation, of this manual.

## Frequently Asked Questions

Q

What do I do when the vertical auger high current alarm is active?

A

Check the speed setting of the vertical auger. Lower the auger speed to reduce the current level of the AC motor. Access the alarm and accept it to clear it.

Q

What do I do when the fluff material does not seem to be going down into the extruder?

A

Check the bulk density of the fluff. It should be above 3 pounds per cubic foot. Usually the grinder blades need adjusting or sharpening, or the grinder screen hole size is too large.



## We're Here to Help

Conair has made the largest investment in customer support in the plastics industry. Our service experts are available to help with any problem you might have installing and operating your equipment. Your Conair sales representative also can help analyze the nature of your problem, assuring that it did not result from mis-application or improper use.

**Additional manuals and prints for your Conair equipment may be ordered through the Customer Service or Parts Department for a nominal fee.**

## How to Contact Customer Service

To contact Customer Service personnel, call:



 **NOTE:** Normal operating hours are 8:00 am - 5:00 pm EST. After hours emergency service is available at the same phone number.

From outside the United States, call: 814-437-6861

You can commission Conair service personnel to provide on-site service by contacting the Customer Service Department. Standard rates include an on-site hourly rate, with a one-day minimum plus expenses.

## Before You Call...

**If you do have a problem, please complete the following checklist before calling Conair:**

- Make sure you have all model, serial and parts list numbers for your particular equipment. Service personnel will need this information to assist you.
- Make sure power is supplied to the equipment.
- Make sure that all connectors and wires within and between control systems and related components have been installed correctly.
- Check the troubleshooting guide of this manual for a solution.
- Thoroughly examine the instruction manual(s) for associated equipment, especially controls. Each manual may have its own troubleshooting guide to help you.
- Check that the equipment has been operated as described in this manual.
- Check accompanying schematic drawings for information on special considerations.

## Equipment Guarantee

Conair guarantees the machinery and equipment on this order, for a period as defined in the quotation from date of shipment, against defects in material and workmanship under the normal use and service for which it was recommended (except for parts that are typically replaced after normal usage, such as filters, liner plates, etc.). Conair's guarantee is limited to replacing, at our option, the part or parts determined by us to be defective after examination. The customer assumes the cost of transportation of the part or parts to and from the factory.

## Performance Warranty

Conair warrants that this equipment will perform at or above the ratings stated in specific quotations covering the equipment or as detailed in engineering specifications, provided the equipment is applied, installed, operated and maintained in the recommended manner as outlined in our quotation or specifications. Should performance not meet warranted levels, Conair at its discretion will exercise one of the following options:

- Inspect the equipment and perform alterations or adjustments to satisfy performance claims. (Charges for such inspections and corrections will be waived unless failure to meet warranty is due to misapplication, improper installation, poor maintenance practices or improper operation.)
- Replace the original equipment with other Conair equipment that will meet original performance claims at no extra cost to the customer.
- Refund the invoiced cost to the customer. Credit is subject to prior notice by the customer at which time a Return Goods Authorization Number (RGA) will be issued by Conair's Service Department. Returned equipment must be well crated and in proper operating condition, including all parts. Returns must be prepaid. Purchaser must notify Conair in writing of any claim and provide a customer receipt and other evidence that a claim is being made.

## Warranty Limitations

**Except for the Equipment Guarantee and Performance Warranty stated above, Conair disclaims all other warranties with respect to the equipment, express or implied, arising by operation of law, course of dealing, usage of trade or otherwise, including but not limited to the implied warranties of merchantability and fitness for a particular purpose.**