

CLS and CHS Tangential Feed Granulators

**Models: CLS-810, CLS-814, CLS-819 and CLS-824,
CHS-810, CHS-814, CHS-819 and CHS-824**

INSTRUCTION MANUAL

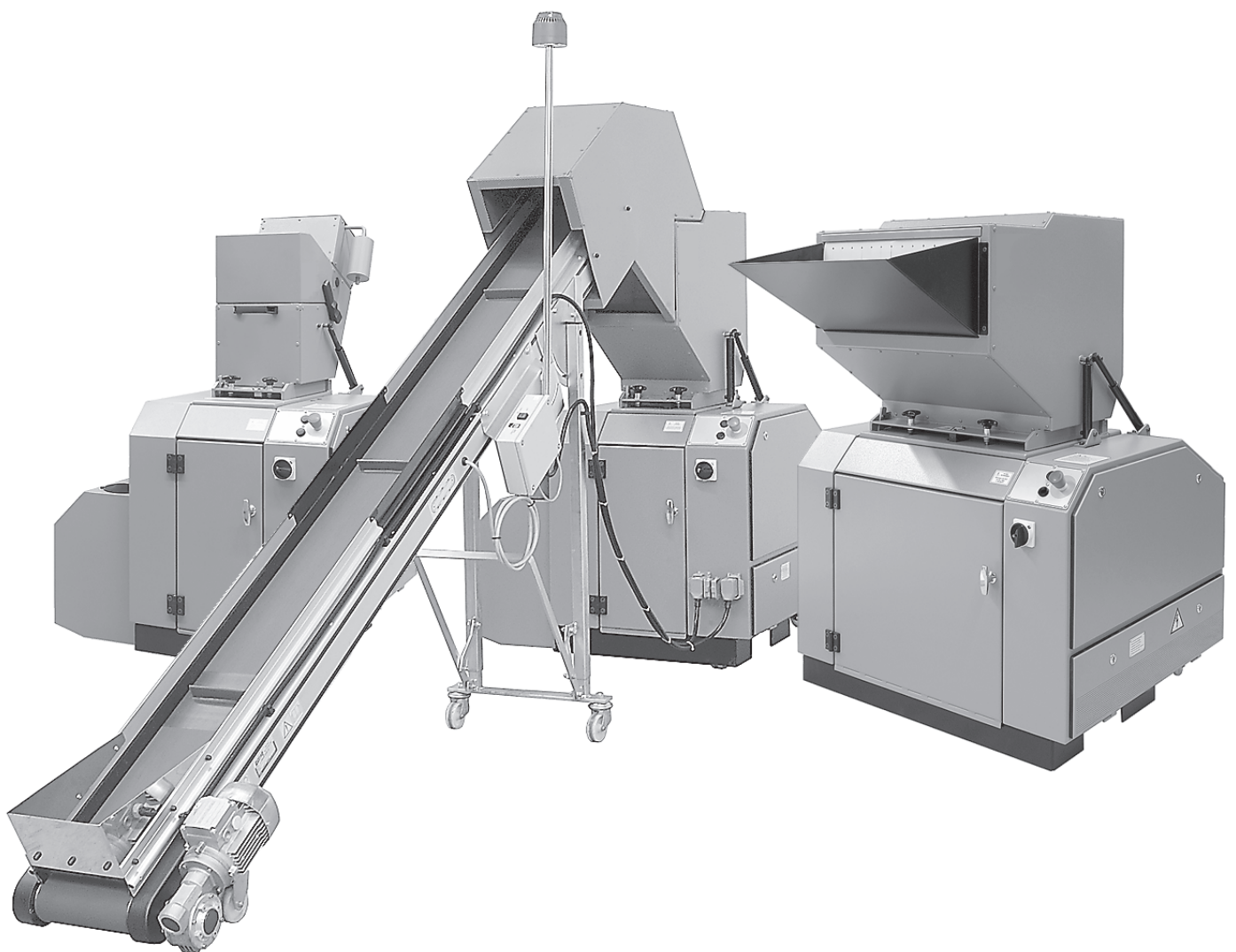

© Copyright

Applies to all texts and illustrations in this instruction manual, completely and in part.
CONAIR

Contents

1. Introduction	1:1
2. Technical specification	2:1
Dimensions	2:1
Types of cutter housings	2:1
Data	2:1
Sound level	2:2
3. Function description	3:1
3.1 General	3:1
3.2 Safety system	3:3
– Main switch	3:3
– Emergency stop	3:3
– Safety switches	3:3
– Important parts which belongs to the granulator safety system	3:4
– Before the granulator can be started should	3:4
4. Security	4:1
4.1 Safety system	4:1
– Markings on the granulator and optional equipment that stipulate caution	4:1
– Parts of the safety system	4:1
– Important parts belonging to the safety system of the granulator	4:1
4.2 Functional description of parts of the safety system	4:2
– Emergency stop	4:2
– Safety switches	4:2
4.3 Safety instructions	4:3
– Safety instructions and safety measures during operation	4:3
– Safety instructions and safety measures concerning the electrical system	4:3
– Safety instructions and safety measures during cleaning, maintenance and service	4:4
4.4 Personal safety equipment	4:5
– Ear protection	4:5
– Protective gloves	4:5
– Protective goggles	4:5
4.5 Safety instructions and caution when changing knives	4:6
– Length, dimensions and strength class on screws and washers	4:6
– Tightening torque and torque wrench	4:6
– Tips for installation of knives	4:7
5. Installation	5:1
5.1 Place of use	5:1
– Floor, foundation, place of use	5:1
– Safety distance when opening the hopper	5:1
5.2 Actions before the first start	5:2
– Clean the granulator from anticorrosive agent	5:2
– Check before the first start	5:2
5.3 Electrical connection	5:2
– Emergency stop	5:2
– Check the direction of rotation of the granulator motor and the blower motor	5:3
– If any direction of rotation is wrong	5:3
5.4 Two hours after first start	5:4
5.5 20 - 30 hours after installation	5:5
5.6 Opening of hopper, granule bin and screen box	5:6
– Stop the granulator	5:6
– Open the hopper	5:6
– Open and remove the granule bin	5:7
– Remove the screen box	5:7
– Changing of screen	5:7
5.8 Closing of screen box, granule bin and hopper	5:8
– Install the screen	5:8
– Install the screen box	5:8
– Install the granule bin	5:8
– Close the hopper	5:8
6. Operation and daily maintenance	6:1
6.1 Start and stop	6:1
– Start	6:1
– Stop	6:2
6.2 Inspection	6:3
– Daily inspection	6:3
– Weekly inspection	6:3

– Monthly inspection	6:4
– Inspection every 6 month or at 1000 running hours	6:4
6.3 Stoppage and overloading of granulator	6:5
– Stoppage in cutter house	6:5
– Hardened lumps in cutter house, screen box and granule bin	6:6
– Stoppage in hopper	6:6
– “20-U” Stoppage in blower and material conveyance system	6:6
6.4 Cleaning	6:8
6.5 Fault finding	6:12
– The granulator does not start	6:12
– The granulator stops for some unaccountable reason	6:13
– The granulators optional equipment does not start or stops for some unaccountable reason ..	6:13
– If the granulator or the optional equipment does not start after normal fault finding	6:14
7. Service	7:1
7.1 Knife changing	7:1
– Safety instructions and caution when changing knives	7:1
– Length, dimensions and strength class on screws and washers	7:1
– Tightening torque and torque wrench	7:1
– Check the type of cutter house	7:2
– Knife clearance	7:2
– Rotating knives	7:2
– Fixed knives	7:3
– To change the knives	7:3
7.1.1 Removing of knives	7:3
– Removing of rotating knives	7:3
– Removing of fixed knives	7:4
7.1.2 Installation of knives	7:4
– Tips for installation of knives	7:4
– Clean all knife positions	7:5
– Clean all knives	7:5
– Use protective gloves	7:5
– New screws and washers should be used at every second installation	7:5
– First install the rear fixed counter knife	7:5
– Install the rotating knives	7:5
– Then install the front fixed counter knife	7:6
– Check the knife installation	7:7
– 2 - 4 hours after knife changing	7:7
7.2 Grinding of knives	7:8
– Cool the knives during grinding	7:8
– Grinding fixture	7:8
– First grind the relief angle	7:8
– Then grind the cutting angle on the knife edge	7:8
– Grinding of rotating knives – granulator with open cutter	7:8
7.3 Transmission	7:10
– Inspection and adjustment of drive belts	7:10
– Inspection of drive belts	7:10
– Adjustment of drive belts	7:11
7.4 Lubrication	7:12
7.5 Cutter belt pulley/Motor pulley	7:13
– Removing	7:13
– Installation	7:13
8. Spare parts list, Overview	8:1
8.1 Cutter house	8:2
8.2 Cutter	8:4
8.3 Cutter, open cutter	8:5
8.4 Knives, 3-step cutter	8:6
8.5 Knives, open cutter	8:7
8.6 Transmission	8:8
8.7 Screen	8:9
8.8 Screen box	8:10
8.9 Outfeed, granule bin	8:11
8.10 Outfeed, blower F-7/F-15	8:12
8.11 Hopper	8:13
8.12 Details to hopper	8:14
8.13 Hopper rear -KUP	8:15
8.14 Hopper device	8:16

8.15 Safety	8:17
8.16 Enclosure	8:18
8.17 Enclosure, transmission	8:19
8.18 Body	8:20
8.19 Tools, accessories and fixtures	8:21
9. Wiring diagram	9:1
9.1 Current sensing relay "Crouzet"	9:2
– Connection	9:2
– Setting	9:2
– Normal setting for this: Y/D-started granulator, Direct-started granulator	9:3
– Exemple	9:3
10. Layout	10:1
11. Options, Overview	11:1
11.1 Pre-setting of rotatinge knives, granulator with open cutter	11:2
– Setting up the knives	11:2
– Installation of pre-set knives	11:2
11.2 Third fixed counter knife	11:3
– Removing	11:3
– Installation	11:3
11.3 Blower F-7 and F-15	11:4
– Safety, installation, maintenance, spare parts	11:4
11.4 Level monitor	11:6
– Setting the paddle monitor sensitivity	11:6
11.7 Band conveyor	11:7
– Safety, installation, electrical connection, start	11:7
– Maintenance, fault finding	11:8
– Spare parts for band conveyor	11:9
12. Transport, lift and storage	12:1
– Unpacking and receiving inspection	12:1
– Lift and transport to place of use	12:1
– Positioning and installation in place of use	12:1
– Storage	12:1
13. Service and maintenance schedule	13:1
Machine data	13:1
Safety, maintenance and service	13:1
Installation	13:2
– Electrical connection	13:2
– 2 hours after first start	13:2
– 20 - 30 hours after first start	13:2
Inspection	13:3
– Weekly inspection	13:3
– Monthly inspection	13:5
– Inspection every 6 month or at 1000 running hours	13:6
Knife changing	13:7
Malfunctions	13:8
Notes	13:9

1. Introduction

This manual is valid for Conair granulators CLS/CHS models.

The model number 810, 814, 819 and 824 indicate the size of the cutter housing.

The additional designations indicate:

- K – Noise encapsulated machine.
- B – Machine with a hopper adapted for band conveyor.
- P – Machine with a hopper adapted for sheet material/profiles.
- U – Machine with an extraction blower.

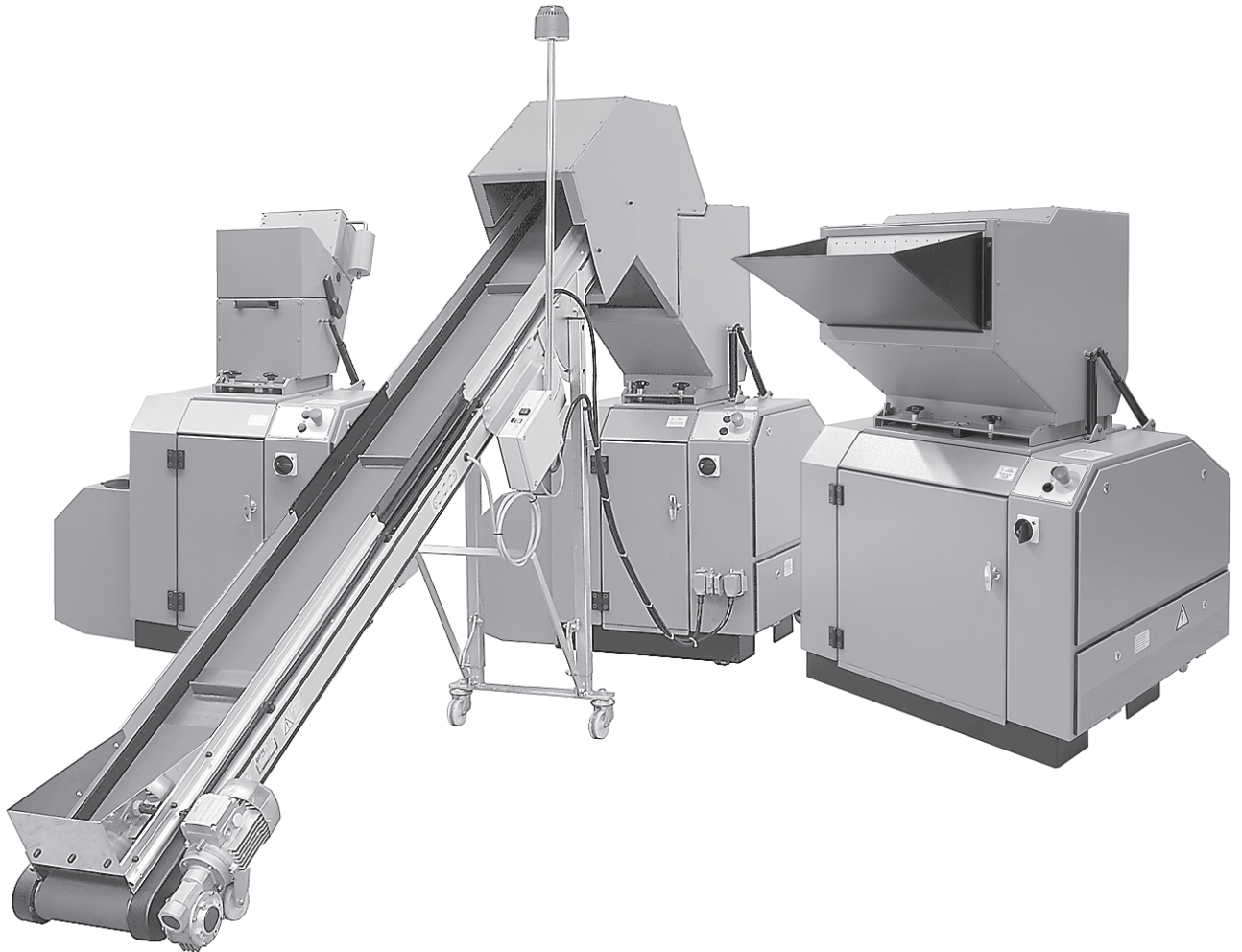

Read the manual before installing and using the machine.



Note! The text and illustrations in the manual refer mainly to an noise encapsulated granulator, because it is the most frequent occurring.



Be careful when the knives are accessible, they are sharp and cause personal injury!

This Conair granulator is designed to granulate waste resulting from injection moulding, blow moulding or extrusion. The plastic waste must be free from contamination such as metal, poisonous, flammable or explosive items or any other substances that in any way are unhealthy.

Permission in writing is required from the supplier of the machine before using it to process any other products or material. The supplier of the machine is always to be consulted in the event of any doubt.

The granulators rotating and fixed knives should always have sharp cutting edges.

The granulator must never be used with unsharpen knives to crush injection moulded, blow moulded or extruded plastic waste. Unsharpen knives causes an unnormal large wear which will seriously damage the granulator.

The granulator is not intended for grinding of wood, household or garden refuse, medications or substances detrimental to health, unless express written permission is obtained from the supplier of the machine.

The size and performance of the granulator is designed and adapted to the type of plastic waste which was specified by the customer before ordering.

For granulation of other products and materials approval should be obtained from the Conair main office for the warranty conditions to apply.

The granulators are designed so that cleaning, maintenance and service can be done quickly and easily, both routine maintenance and changing of material.

All service is to be performed by trained service personnel.

This manual contains instructions for both installation, operation and service:

Chapter 5 contains instructions for installation directed to service personnel.

Chapter 7 contains instructions directed to service personnel.

Chapter 11 contains the machine's optional equipment.

Chapter 13 contains the machine's installation and service schedule. The installation- and service schedule must be filled in and signed, otherwise all machine guarantee and Conair's product responsibility will become invalid.

The other chapters contain instructions for the operator.

Additional items delivered with the granulator include:

- One feeler gauge 0.20 mm.
- and touch-up paint.

Any modification or conversion of the granulator is subject to written approval from Conair's main office, with the object of preventing injury or damage and to maintain the guarantee and product liability.

In event of any questions, please contact Conair's local agent, or the Conair main office.

Main Office:

Conair

One Conair Drive

Pittsburgh, PA 15202

USA

Phone: 412-312-6000

Fax: 412-312-6227

Website: www.conairgroup.com

2. Technical specification

CLS-810, CLS-814, CLS-819 AND CLS-824

TPGM020-0707

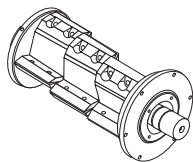
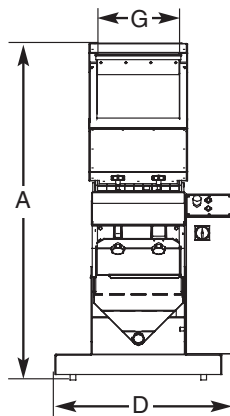
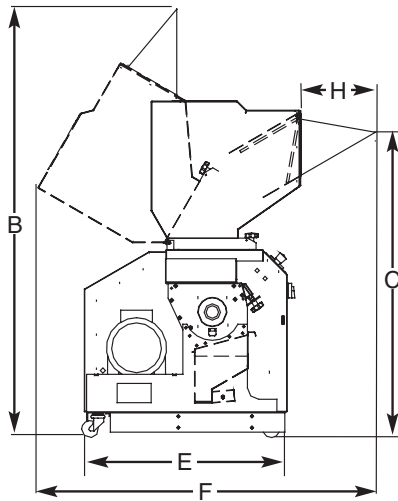

STANDARD STAGGERED ROTOR
with disposable, cassette knives

MODELS	CLS-810	CLS-814	CLS-819	CLS-824
Performance characteristics				
Throughput* lb/hr (kg/hr)	150 (70)	200 (90)	250 (115)	300 (135)
Cutter chamber opening in. (mm)	8.7 x 9.5 {220 x 240}	8.7 x 14.2 {220 x 360}	8.7 x 18.9 {220 x 480}	8.7 x 23.6 {220 x 600}
Cutting circle in. (mm)	7.88 {200}	7.88 {200}	7.88 {200}	7.88 {200}
Rotor speed rpm	312	312	312	312
Standard motor power Hp (kW)	5 (4)	7.5 (5.5)	7.5 (5.5)	7.5 (5.5)
Drive type	belt drive			
Hopper type	hand, robot, conveyor feed			
Vacuum discharge side	front†			
Screen mesh sizes	5/32, 3/16, 1/4, 5/16, 3/8, in. {4, 5, 6, 8, 10, mm}			
Rotor type	staggered rotor			
Knives				
Number of rotating knives (knives x segments)	3 X 2	3 X 3	3 X 4	3 X 5
Number of bed knives	2 (optional 3rd)	2 (optional 3rd)	2 (optional 3rd)	2 (optional 3rd)
Dimensions inches (mm)				
A - Height - hopper closed	58 {1480}	58 {1480}	58 {1480}	58 {1480}
B - Height - hopper open	73 {1856}	73 {1856}	73 {1856}	73 {1856}
C - Infeed height - floor to feed tray	53 {1342}	53 {1342}	53 {1342}	53 {1342}
D - Width	26 {670}	31 {790}	36 {910}	41 {1030}
E - Base depth	35 {890}	35 {890}	35 {890}	35 {890}
F - Overall depth	58 {1482}	58 {1482}	58 {1482}	58 {1482}
G - Feed hopper opening - width	9.5 {240}	14 {360}	19 {480}	24 {600}
H - Feed hopper opening - depth	8.6 {218}	8.6 {218}	8.6 {218}	8.6 {218}
Weight lb (kg)				
Installed	926 {420}	1014 {460}	1157 {525}	1257 {570}
Shipping	983 {446}	1058 {480}	1202 {545}	1301 {590}
Voltages Total amps based on standard motor				
208V/3 phase/60 Hz	17.5	NA	NA	NA
230V/3 phase/60 Hz	15.2	25	22	22
460V/3 phase/60 Hz	7.6	12	11	11
575V/3 phase/60 Hz	6.1	10	9	9
Noise level‡				
Standard with hopper soundproofing	85-90 dbA			
Optional with hopper and base soundproofing	80-85 dbA			
Optional with no soundproofing	90-95 dbA			

SPECIFICATION NOTES:

* Throughput is based on a 5/16 inch (8mm) screen. Throughput rates are provided as a capacity guideline only. Throughput will vary according to the selected screen size, the shape, thickness and properties of the material to be cut. Consult Conair for a material test or help determining the correct granulator model for your application.

† CLS granulators ordered with the optional base sound enclosure will have a rear discharge.

‡ Noise level will vary according to material type being processed and the granulator configuration. These ranges are based on tests using SPI standards.

Specifications may change without notice. Check with a Conair representative for the most current information.

OPTIONS

- Discharge: manual, vacuum (standard), blower
- Base sound enclosure
- Hardened cutter housing
- Third bed knife
- Nitro-carburized screen

MOTOR OPTIONS ●=standard ○=optional	CLS-810	CLS-814	CLS-819	CLS-824
	5 Hp {4.0 kW}	●	N/A	N/A
7.5 Hp {5.5 kW}	○	●	●	●

Technical specification

CHS-810, CHS-814, CHS-819 AND CHS-824

TPGS019-0707

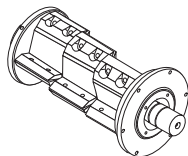
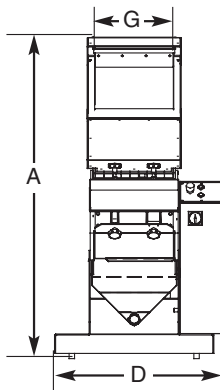
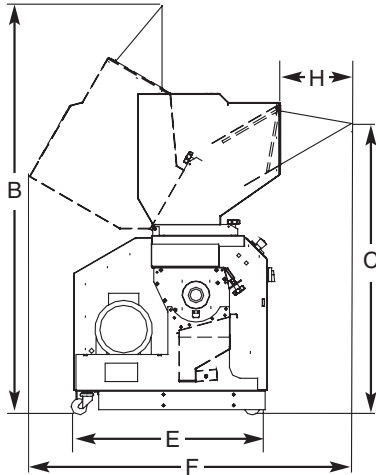

STANDARD STAGGERED ROTOR
with disposable, cassette knives

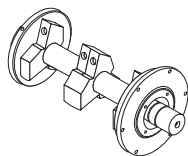

OPTIONAL OPEN ROTOR
with scissor-cutting, slant knives

CHS-810, CHS-814, CHS-819 AND CHS-824

MODELS	CHS-810	CHS-814	CHS-819	CHS-824
Performance characteristics				
Throughput* lb/hr {kg/hr}	200 {90}	250 {115}	330 {150}	400 {180}
Cutter chamber opening in. {mm}	8.7 x 9.5 {220 x 240}	8.7 x 14.2 {220 x 360}	8.7 x 18.9 {220 x 480}	8.7 x 23.6 {220 x 600}
Rotor speed rpm	485	485	485	485
Cutting Circle in. {mm}	7.88 {200}	7.88 {200}	7.88 {200}	7.88 {200}
Standard motor power Hp {kW}	5 {4}	7.5 {5.5}	7.5 {5.5}	7.5 {5.5}
Drive type	belt drive			
Hopper type	hand, robot, conveyor - standard (sheet, roll, profile, side feed - optional)			
Vacuum discharge side	front †			
Screen mesh sizes	5/32, 3/16, 1/4, 5/16, 3/8, in. {4, 5, 6, 8, 10, mm}			
Rotor type	staggered rotor - open rotor optional			
Knives				
Number of rotating knives {knives x segments}	3 X 2	3 X 3	3 X 4	3 X 5
Number of bed knives	2 (optional 3rd)	2 (optional 3rd)	2 (optional 3rd)	2 (optional 3rd)
Dimensions inches {mm}				
A - Height - hopper closed	58 {1480}	58 {1480}	58 {1480}	58 {1480}
B - Height - hopper open	73 {1856}	73 {1856}	73 {1856}	73 {1856}
C - Infeed height - floor to feed tray	53 {1346}	53 {1346}	53 {1346}	53 {1346}
D - Width	26 {670}	31 {790}	36 {910}	41 {1030}
E - Base depth	35 {890}	35 {890}	35 {890}	35 {890}
F - Overall depth	58 {1482}	58 {1482}	58 {1482}	58 {1482}
G - Feed hopper opening - width	9.5 {240}	14 {360}	19 {480}	24 {600}
H - Feed hopper opening - depth	8.6 {218}	8.6 {218}	8.6 {218}	8.6 {218}
Weight lb {kg}				
Installed	926 {420}	1014 {460}	1157 {525}	1257 {570}
Shipping	983 {446}	1058 {480}	1202 {545}	1301 {590}
Voltages Total amps based on standard motor				
208V/3 phase/60 Hz	17.5	24	24	24
230V/3 phase/60 Hz	15.2	22	22	22
460V/3 phase/60 Hz	7.6	11	11	11
575V/3 phase/60 Hz	6.1	9	9	9
Noise level‡				
Standard with hopper soundproofing	85-90 dbA			
Optional with hopper and base soundproofing	80-85 dbA			
Optional with no soundproofing	90-95 dbA			

SPECIFICATION NOTES:

* Throughput is based on a 5/16 inch (8mm) screen. Throughput rates are provided as a capacity guideline only. Throughput will vary according to size, shape, thickness and properties of the material to be cut, as well as the desired size of the granulate. Consult Conair sales for a material test or help determining the correct granulator model for your application.

† CHS granulators ordered with the optional base sound enclosure will have a rear discharge.

‡ Noise level will vary according to material type being processed and the granulator configuration. These ranges are based on tests using SPI standards.

Specifications may change without notice. Check with a Conair representative for the most current information.

OPTIONS

- Discharge: manual, vacuum (standard), blower
- Base sound enclosure
- Hardened cutter housing
- Third bed knife
- 3-blade open rotor
- Nitro-carburized screen

MOTOR OPTIONS ●=standard ○=optional	CHS-810	CHS-814	CHS-819	CHS-824
	5 Hp {4 kW}	●	N/A	N/A
7.5 Hp {5.5 kW}	○	●	●	●
10 Hp {7.5 kW}	○	○	○	○
15 Hp {11 kW}	○	○	○	○

3. Functional description

3.1 General

The granulator is designed to granulate injection moulded, blow moulded or extruded plastics waste.

The plastic waste must be free from contamination such as metal, poisonous, flammable, explosive or any other substances that in any way are unhealthy.

The granulator is controlled by start/stop controls on a control panel.

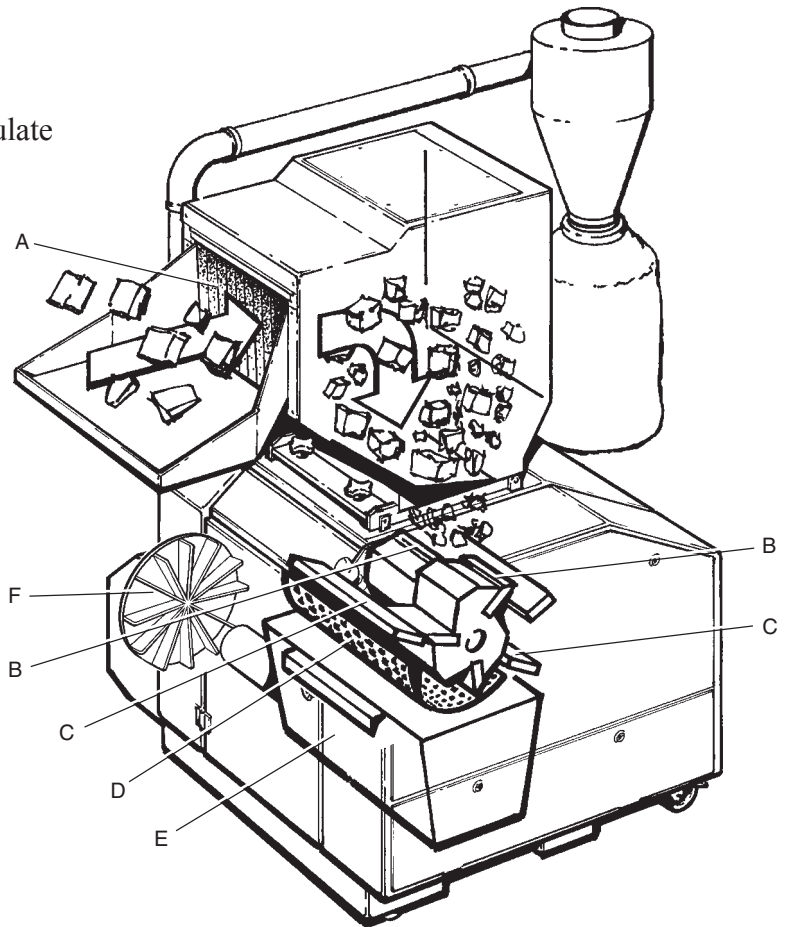

The plastic waste is fed in to the hopper “A” and falls down into the cutter house, where rotating knives “B” cut the plastics against fixed knives “C” to granulate.

A perforated screen “D” determines the size of the granulate.

The screen is placed in the screen box, located in the lower section of the cutter house can easily be changed to give the desired granulate size.

The granulate passes the screen and falls down into the granule bin “E” which collects the granulate.

In standard design is the granule bin to be manually emptied.

Granulators with the additional designation “-U” are equipped with an extraction blower “F” which sucks the granulate out from granule bin for further transport, or to an cyclone which separates air and granulate.

On granulator models with the additional designation “-B” is the hopper adapted to suit a band conveyor.

The granulator is optimised prior to order and adapted to the customer requirements, with the aid of 4 cutter-house widths: 20-24, 20-36, 20-48 and 20-60.

and 2 types of cutter:

- Standard 3-step cutter
- Open cutter

Types of cutter housings

In standard design have the cutter house an 3-step cutter with 3 rotating knives and 2 fixed counter knives.

The standard cutter house can later on be changed if new needings arises. An rear side with a 3:rd fixed counter knife can be installed. For to change the type of cutter house please contact Conair's head office.

Standard cutter house

3-step cutter with 3 rotating knives.

The cutter house has 2 fixed counter knives.
Fixed counter knife no. 1 and no. 2.

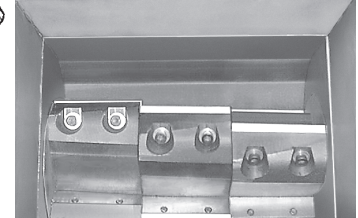
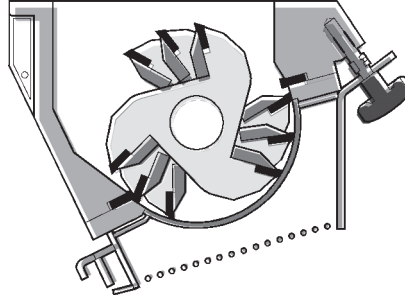

Cutter house with open cutter

Cutter with 3 rotating knives.

The cutter house has 2 fixed counter knives.
Fixed counter knife no. 1 and no. 2.

Space is available for one additional fixed counter knife which gives higher capacity.

Fixed counter knife no. 3.

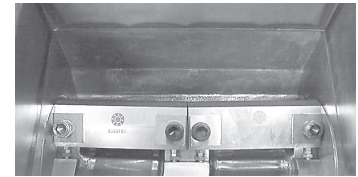
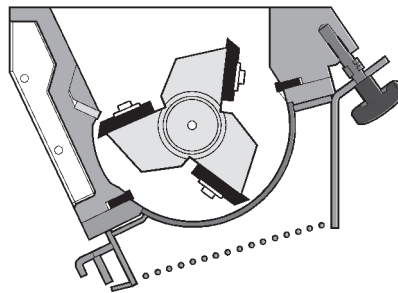

Easy cleaning



The CLS/CHS granulator have an good accessibillity for easy and quick cleaning.

The hopper is easy to open and all places which need to be cleaned, before changing of colours or type of plastics, have an easy and quick accessibillity.

Metal detector

Granulator models equipped with a band conveyor, can also be equipped with a metal detector.

Knives

The granulator may never be used with unsharpen knives to crush injection moulded, blow moulded or extruded plastic waste. Unsharpen knives causes an unnormal large wear which will seriously damage the granulator.

Rotating knives

Granulator with 3-step standard cutter

- the rotating knives are of disposable type and should be replaced when necessary.

Granulator with open cutter

- the rotating knives can be re-sharpened.

Grinding is easy to carry out by using an special grinding fixture.

The fixture is an option which not is included in the machine delivery.

Fixed knives

The granulator's fixed knives are turn able and two cutting edges can be used.

The fixed knives can not be re-sharpened, the knives are of disposable type and should be replaced when necessary.

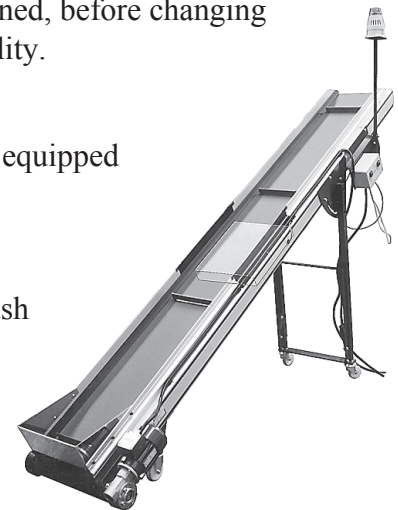

3.2 Safety system

The granulator has a safety system to prevent access to dangerous components during operation.

The granulator has knives which rotate with great force and high speed. The granulator is therefore equipped with main switch, emergency stop and safety switches to avoid personal injury.

The safety system must not be changed or modified under any circumstances.

If the safety system of the granulator is changed or modified, the machine can be dangerous to use, presenting a serious risk of personal injury.

All maintenance and service to the safety system of the granulator should be carried out by personnel with the necessary knowledge.

If the safety system of the granulator is modified in any way, Conair's responsibility under the Machinery Directive ceases to apply.

Only spare parts from Conair may be used when replacing safety components.

Safety instructions

Instructions and safety measures in this manual are to be followed to avoid personal injury and damage to the machine.

Main switch

The main switch is located direct under the control panel.

The main switch breaks all three poles of the incoming 3-phase power.

Emergency stop

One emergency stop is located on the control panel.

The granulator can be equipped with extra emergency stops.

The emergency stop is activated by pressing the button.

Resetting is effected by turning the button in the direction of the arrow (counterclockwise).

Safety switches

The CLS/CHS granulator models have safety switches of the position switch type:

The safety switches cuts the control current in the granulator, so that the granulator stops if the hopper or screen box changes position.

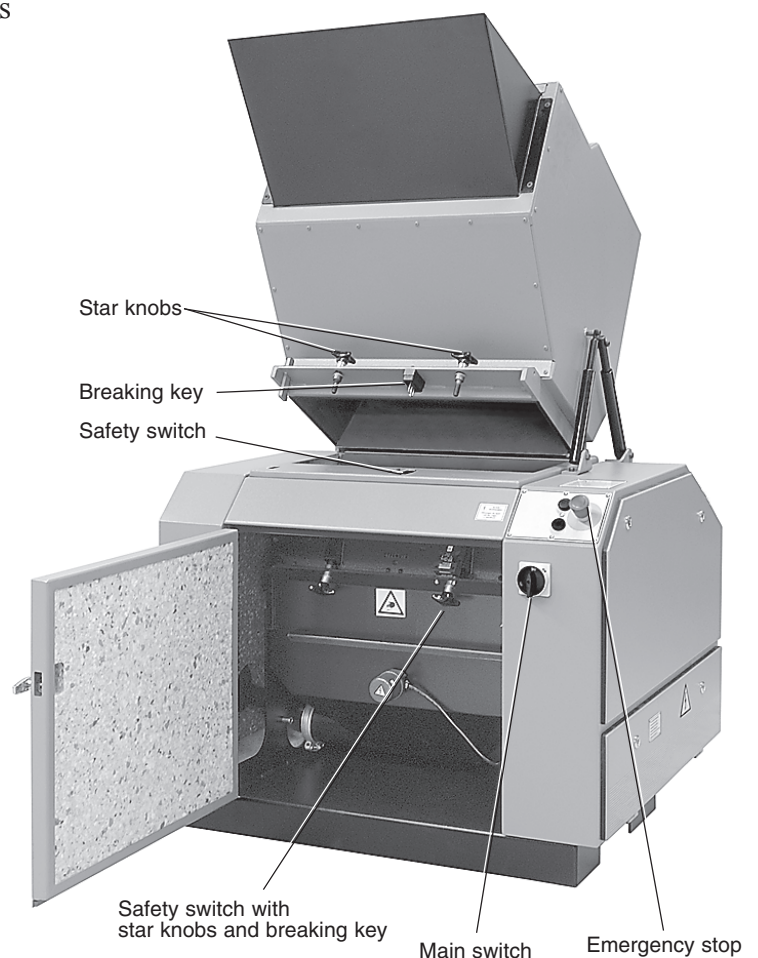

The standard granulator has 2 safety switches:

- 1 Safety switch at the hopper, between the hopper and the cutter house.
A star knob in combination with a breaking key and a electric switch.
The safety switch sense that the hopper seals tight against the cutter house.
If the hopper changes position, the granulator stops.
- 1 Safety switch at the screen box, between the screen box and the cutter house.
A star knob in combination with a breaking key and a electric switch.
The safety switch sense that the screen box seals tight against the cutter house.
If the screen box changes position, the granulator stops.

Granulators which have a screen with a larger hole diameter than 8 mm, have an extend security.

- 1 Safety switch is located at the granule bin.
The safety switch at the granule bin, sense that the granule bin is installed.
The granulator can not be started if the granule bin not is installed.

The granulator can depending on optional accessories be equipped with further security.

Check therefore in the electric circuit diagram for your granulator, to see, how many safety switches just your granulator is equipped with.

Star knob

The star knobs are important components in the safety system of the granulator.

It should take such a long time to unscrew the star knobs, so that the cutter has stopped before the granulator can be opened.

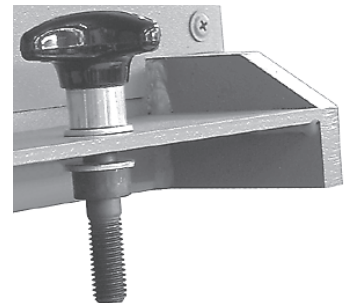

NOTE! The star knob is permanent attached on the hardened screw an can not be removed.



NOTE! The thread length of the screw may never be changed.
For to change a star knob, please contact Conair’s local distributor or Conair’s main office.



NOTE! If any star knob is changed in any way Conair’s responsibility under the Machinery Directive ceases to apply.

Important parts which belongs to the granulator safety system

- “CHS/CLS-KB” The inlet part to hopper should always be installed during operation.
- The screen box should always be properly installed.
- The granule bin should always be properly installed.

Before the granulator can be started should

- The hopper be properly closed.
The safety switch sense that the hopper seals tight against the cutter house.
- The screen box should be properly installed.
The safety switch sense that the screen box seals tight against the cutter house.
- The granule bin should be properly installed.

4. Security



Read through the whole instruction manual before installing and using the machine.

All service must be done by trained and competent personnel.

Any modification or conversion of the granulator is subject to written approval by Conair, with the object of preventing injury or damage and to maintain the guarantee and product responsibility.

Instructions for lift and transport of the granulator are in chapter 12 in this instruction manual.

4.1 Safety system

The granulator has knives which rotate with great force and high speed. The granulator is therefore equipped with a safety system to prevent contact with dangerous parts during operation in order to avoid personal injury.

Marking of the granulator and optional equipment where caution stipulates

The granulator and the granulator's optional equipment that imply danger, the need of caution or particular attention are marked accordingly.



WARNING! Dangerous voltage!

This sign is on the door to the electrical cabinet and connection boxes.



WARNING! Cutting or pinch risk!

This sign is placed where there is a risk of being cut or pinched.



WARNING! Be careful!

This sign is located by all danger areas, where care and extra attention is required.



WARNING! Pinch risk!

This sign is placed where there is a risk of being pinched, extra attention is required.

The instruction manual contains the same markings where particular attention is emphasised.

Details in the safety system

The details in the safety system shall prevent contact with dangerous items during operation in order to avoid personal injury.

The safety system includes:

- Emergency stop
- Safety switches– Star knobs with electrical position switches.

The granulator's safety system may not be changed or modified under any circumstances.

If the safety system is modified, Conair's responsibility under the Machinery Directive ceases to apply.

The function of the safety system is described in chapter 3 of the instruction manual.

Only spare parts from Conair may be used to replace components of the safety system.

Important details which belongs to the granulator's safety system

The screen box and the granule bin should before start always be properly installed.

Granulator model “-KB”, the hopper inlet part should always be installed during operation.

4.2 Functional description of details in the safety system

Emergency stop

Red round push-button on yellow base, is on the control panel.

The granulator can be fitted with additional emergency stops, depending on the function and optional equipment.

The emergency stop is activated by pressing the button.

Resetting is effected by turning the button in the direction of the arrow (counterclockwise).

Resetting of a emergency stop button with key lock is effected by:

- Open (unlock) the emergency stop button lock using a key, then turn the button in the direction of the arrow (counterclockwise).



Safety switches

A star knob in combination with a breaking key and an electrical switch

Star knobs in combination with a breaking key and an electrical switch at the hopper and the screen box, cuts the control current in the granulator, so that the granulator stops, if a safe position is changed or opened.

A star knob should take enough time to unscrew, so that the cutter has stopped before the granulator can be opened.

When the granulator has a screen with the hole diameter 8 mm or larger, the granulator has an extend security. In addition, there is 1 safety switch located at the granule bin. The granulator should not be able to start, if the granule bin is not installed.

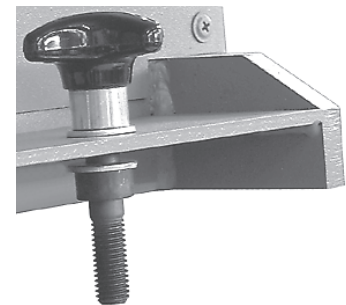

4.3 Safety instructions

The following safety measures, should always be followed when using the granulator:

Safety instructions and safety measures during operation



- At least one emergency stop button should always be within reach of the operator.
- It should not be possible to start the granulator, before the hopper and the screen box are properly closed.
- The granulator may not be used without granule bin. The granule bin is part of the granulator's security. The granule bin should always be installed during operation.



- Flammable material or material which is contaminated by flammable substances/liquids may not be processed in the granulator.

Serious risk of fire or explosion.



- Never remove the protective grids or pipes connected to the outfeed, granule bin or blower.
- Never remove the flaps from hopper.

Blowers



- Conair's blowers are intended for dust- and material conveying.
The temperature of the conveyed material must never exceed 80°C.
- The blowers may not be used in humid environments, unprotected outdoors, in explosive atmospheres, or in surroundings where the temperature exceeds 40°C or goes below -20°C.



- The stream of air from the discharge opening is powerful.
WARNING! Granulate and objects which have been sucked in to the blower, will be thrown out with a very high speed and can cause personal injury.

Never put a hand directly in front of the blower discharge opening.

Granulator with band conveyor



- Be careful so that conveyor band with dogs do not grip clothings, arms or feet.
- If the band conveyor is used for hot plastic waste:
Ensure that the hot plastic waste is deposited on the middle of the band, ie, uneven heating of the band could cause it to run askew.

Safety instructions and safety measures concerning the electrical system



- Electrical installation must only be done by a competent electrician!
- The electrical cabinet of the machine contains hazardous high voltage.
- The door to electrical cabinet may never be opened when the granulator is in operation.
- Before the granulator is opened for service and maintenance. Break always the power supply with the main switch! Then block or lock the knob to the main switch!



- Never insert fingers, hands or arms into openings of the granulator, if the knob to the main switch is not in "0" (Off) and locked position.



- The key to the electrical cabinet is a safety component.
The key must be kept by the person who is responsible for the granulator's security, service and maintenance.
- Never change or modify the basic electrical settings of the granulator, without first obtaining permission from the Conair main office.
If the granulator settings are changed, the machine can be seriously damaged.
All Warranties and Conair's Product Liability will be void, if the basic settings of the granulator are changed.
- All electrical maintenance and service, must be done by trained and competent personnel.

Safety instructions and safety measures with regard to cleaning, maintenance and service



- All service must be carried out by trained personnel in order to avoid personal injury or damage to the machine.



- **WARNING!** Granulate and plastic rests on the floor can cause risk of slipping!
Risk of slipping depending of granulate and plastic rests, is especially hazardous when the granulator is opened, for cleaning, maintenance or service.



- Always use protective protective goggles and protective gloves during cleaning, maintenance and service.



- Take care when the knives are accessible, they are sharp and can cause personal injury.
- Never try to stop a cutter by hand when it is moving, even if the moving is slowly.

Cutter, cutter shaft, cutter belt pulley, and poss. flywheel is a heavy unit. The energy of a cutter in motion is considerable.

The danger of injury to fingers and hands is very great.



- There is a danger of being crushed when opening or closing the hopper, screen box and granule bin, be careful!
- **NOTE!** Never use help when cleaning the granulator. Carry out the cleaning alone and observe caution!

The risk of injuring fingers or hands increase, if two or more persons are works to clean the granulator.

- The key to the electrical cabinet must be kept by the person who is responsible for granulator security, service and maintenance.

The key is a safety component.

Knives



- The machine contains rotating knives. They are sharp and can cause personal damage, even when they are not rotating.



- Be careful when handling of knives, they are sharp and can cause personal injury.
- If the cutter must be turned manually, do this with very great care!



- Conair's knives are made of hardened steel.

NOTE! Hardened steel knives are brittle and can crack if they are dropped or handled carelessly.



- Grinding of hardened knives requires knowledge.

Please let a specialist with experience carry out the grinding of knives.

Transmission



- There is a pinch risk at inspection and adjustment of the drive belt tension.

WARNING! Pinch risk between pulleys and drive belts.

Granulator with band conveyor



- During maintenance of band conveyor, pull out the connector from the electrical cabinet!

4.4 Personal safety equipment

Ear protection



Conair recommends that ear protection is used during all granulation of plastics.

Granulation of hard plastics, can cause high and dangerous sound.

Observe also that low sound levels during a long time is dangerous.

Reduce the risk of damage to hearing

Use ear defenders or ear plugs.

Avoid standing in front of the granulator hopper's inlet opening.

Signs of overload after granulating plastic details and plastic lumps are:

- Ringing sound, tones or pain in the ears.
- Difficulty in hearing people speaking when the granulator has stopped.
- A sense of water in the ears.

Protective gloves



Be careful at all handling of knives, they are sharp and can cause personal injury.

Use protective gloves when changing knives, so as not to injury fingers or hands.

Always use protective gloves during cleaning, maintenance and service!

Protective goggles



Conair recommends that safety goggles are used during all granulation of plastics.

Always use protective goggles during cleaning, maintenance and service!

4.5 Safety instructions and caution when changing knives

The following safety measures and caution, shall be observed when changing knives:



NOTE! Make sure that there never are any granulate or plastic rests on the floor during changing of knives.

WARNING! Granulate and plastic rests on the floor can cause risk of slipping!

If anyone slips or falls during changing of knives, or during handling of knives, it can cause serious personal injury!

WARNING!

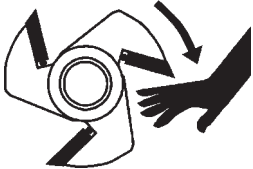

NOTE! The granulator's cutter auto-rotates during removing or installing of rotating knives.

The cutter auto-rotates when the centre of gravity becomes unstable when knives are removed or installed.

Therefore, be very careful during knife changing, so as not to injure fingers or hands.



OBSERVE! Never use help during removing or installing of rotating knives.

Always carry out knife changing alone, for to minimise the risk of injury fingers or hands.

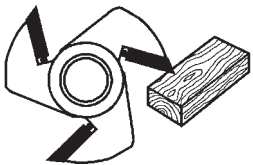

When removing or installing the screws with torque to rotating knives, block the granulator's cutter against the cutter house by using a strong block of wood, so that the cutter not can rotate or glide.

Be careful when handling the knives, they are sharp and can cause personal injury.



Always use protective gloves during knife changing!



Each time the set of knives is changed, the screws and the washers which retain the knives should be replaced by new ones.

Every second time re-sharpened knives are installed the screws and the washers which retain the knives should be replaced by new ones.



At installing, always install all the rotating knives on the cutter, so that the cutter will be balanced.

Length, dimension and strenght class on screws and washers

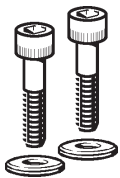

All the screws and the washers which retain the knives are of high strength class.

Only screws and washers supplied by Conair may be used for installing knives.

If not screws and washers from Conair are used, with correct length, dimension and strength class, Conair's responsibility and guarantee become invalid.

Tightening torque and torque wrench



It is very important that the knives are torqued to correct tightening torque.



All screws must be tightened using a torque wrench to the specified tightening torque which is stated in the instruction manual.

If a torque wrench is not used, or if screws are not tightened to the specified tightening torque which is stated in the machine's instruction manual, Conair's responsibility and guarantee become invalid.

Tips for installation of knives



Mark each knife, with a felt-tip pen when each task is carried out:



-  = The knife is installed with a light tightening torque and the rear edge is properly pressed in against the knife position.
-  = The knife screws are torqued to the correct torque.
-  = The knife clearance has been re-checked and is correct.

During installation of pre-set knives “Open cutter”:

Mark each knife, with a felt-tip pen when each task is carried out:

-  = The knife clearance is correctly set in the pre-setting fixture.
-  = The knife is installed and the screws are torqued to the correct torque.
-  = The knife clearance has been re-checked and is correct.

5. Installation



Read through the whole chapter 5 before installing the machine.

All instructions must be followed in the order shown to avoid damage.

Lift and transport



Read and follow the instructions in chapter 12 for lifting and transportation of the granulator.



5.1 Place of use

A free space is needed around the granulator so that cleaning, service and maintenance can be carried out.

Floor, foundation, place of use

Check and make sure that the floor on the place of use is horizontally and is sufficiently strong for the granulator in operation.

If the floor on place of use is uneven, should it be levelled before installation.

Safety distance when opening the hopper



NOTE! When opening the granulator hopper should a safety zone of at least 600 mm be kept clear behind the granulator hopper, when the hopper is opened.

Check the layout of the granulator in chapter 10 to see how much space your granulator requires.

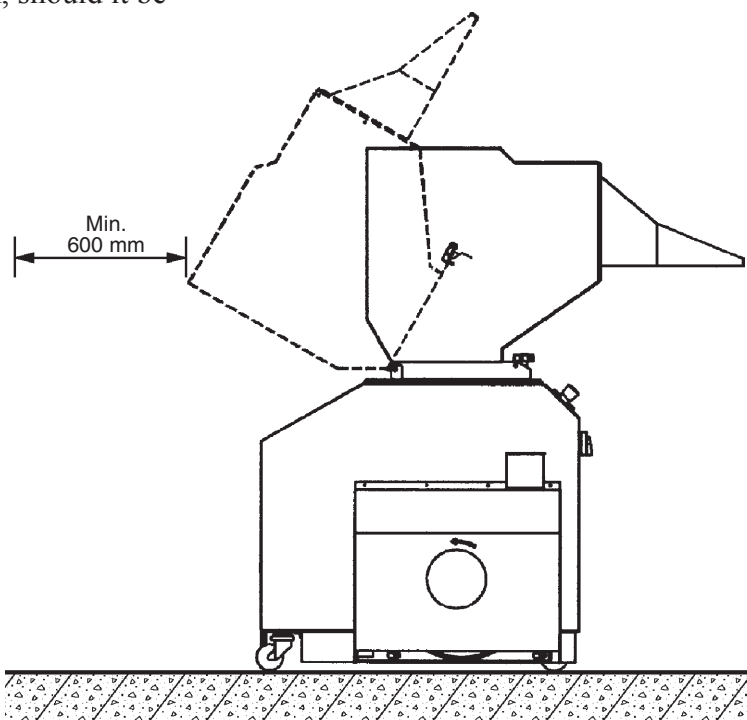

5.2 Actions before the first start

Clean the granulator from anticorrosiv

All unpainted parts of the machine are tre oil as protection prior to transportation an Clean the granulator from anticorrosive ag Remove the anticorrosive agent using low White spirit or cold degreasing agent. Then wipe dry and clean with lintless rag.

Check before the first start

- Check so that the granulator stands stable and in horizontal level.
- Check that the granulator’s emergency stop knob always can be reached of the operator, or that at least one emergency stop knob always can be reached of the operator in the working range of the granulator, including the granulator’s optional equipment such as band conveyor, shredder, dust filter, etc.



- Check tightening torque of screws to the knives.

Check tightening torque to the fixed knives

- rear (no. 1), front (no. 2) and poss. third fixed knife 40 Nm.

Check tightening torque to the rotating knives:

- granulator with 3-step standard cutter 75 Nm.
- granulator with open cutter 220 Nm.

For to check the knives tightening torque and the knife clearance, read chapter 7.1 “Installation of knives”.



- Check the knife clearance using a feeler gauge, the clearance must be 0.15 - 0.25 mm.

NOTE! Sign the executed inspection in the machine maintenance schedule.

5.3 Electrical connection

Connect the granulator to the mains power supply. The rated connecting voltage (Volt) and size of fuse (Ampere) for the machine is stated in the electrical circuit diagram.



NOTE! The granulator may only be connected to the mains supply by an authorised electrician.

The granulator is connected for a right-hand rotating field on delivery.

Check the phase sequence of the power supply using a phase-sequence indicator and connect the granulator with a connector to the mains power supply.



Emergency stop

The emergency stop knob on the control panel should always be within reach of the operator during operation and feeding of granulation gods.

If the operator cannot reach the emergency stop knob on the control panel, during operation of the granulator. The granulator must be fitted with at least one additional emergency stop by the responsible electrician as part of the initial installation.

At least one emergency stop knob shall always be within reach of the operator in the working range of the granulator, including the granulator optional equipment such as band conveyor, shredder, dust filter, etc.

Check the rotation direction of the granulator motor and the blower motor:

Check so that the granulator stands stable and in horizontal level.

- Connect the granulator's connector to the mains power supply.
- Turn the main switch to position "1" On.
- Ensure that the emergency stop is not activated.
- Check that the star knobs to hopper and screen box are properly tightened to stop.
- Granulator with 8 mm screen hole or larger. Check that the star knob to granule bin is properly tightened to stop.
- Open and lift off the upper door on rear side of the granulator.
- Start the granulator, press the "Start"-button and stop it immediately again, press the "Stop"-button.
- Before the motor have had time to stop, check that the rotation direction of cutter belt pulley consider with the arrow on the pulley.
- Granulator with blower "CLS/CHS-U", – check that the rotation direction of the blower matches with the arrow on blower cover.

NOTE! Shown with optional feed tray.

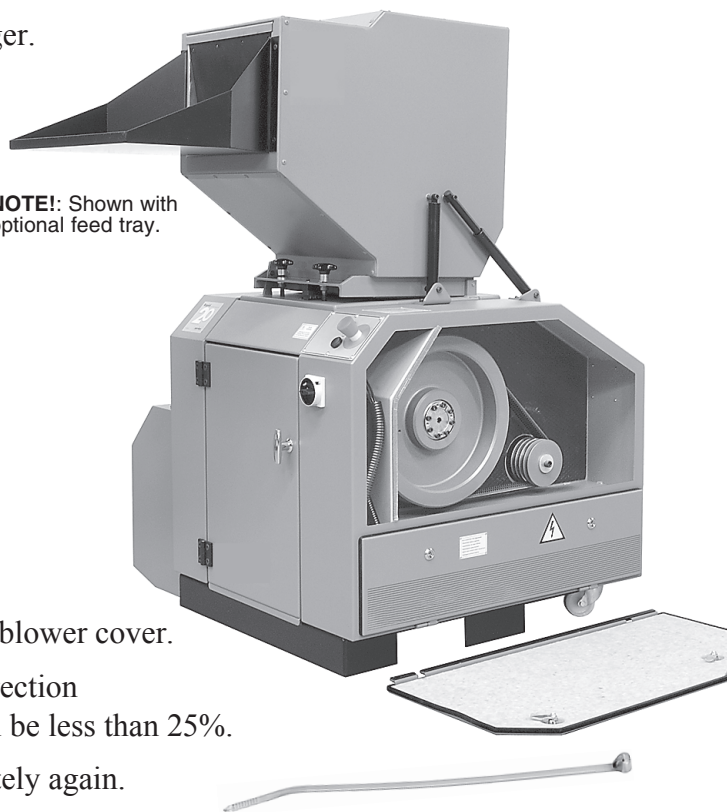

NOTE! The blower blows even if the direction of rotation is wrong, but the capacity will be less than 25%.

Tip! Start the motor and stop it immediately again.

Before the blower motor stops, – carefully insert the end of a cable tie at the rear through the ventilation opening of the motor and feel in which way the motor is rotating.

- Granulator with band conveyor "CLS/CHS-B", – check the direction of the conveyor belt.

If any direction of rotation is wrong:

- Press the "Stop"-button.
- Remove the granulator's connector from the mains power supply.
- Turn the main switch to position "0" Off.
- Shift two incoming phases in the connector from the mains power supply.

NOTE! Sign the executed electric installation in the machine maintenance schedule.

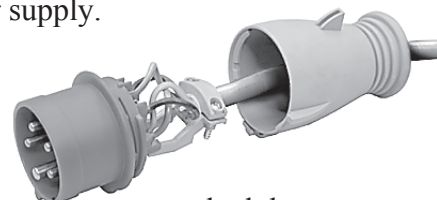

5.4 Two hours after first start

1. Check the tightening torque on all the screws which fasten the granulator's knives.
Read chapter 7.1 "Knife changing".

First check the screws which fasten the fixed knives.

Then check the screws which fasten the rotating knives.

2. Check the knife clearances between all the granulator's rotating knives and the fixed knives, check against both the rear and the front fixed knife (fixed knife no. 1 and fixed knife no. 2).

The knife clearance should be 0.15 - 0.25 mm.

3. Check the tightening torque on the 4 screws which retains the granulator motor to the motor locking rules.

"CLS/CHS-K" Open the door.

Undo and remove the rear protective cover above the motor.

Undo and remove the granule bin and screen box, then are the front retaining screws accessible to the motor.

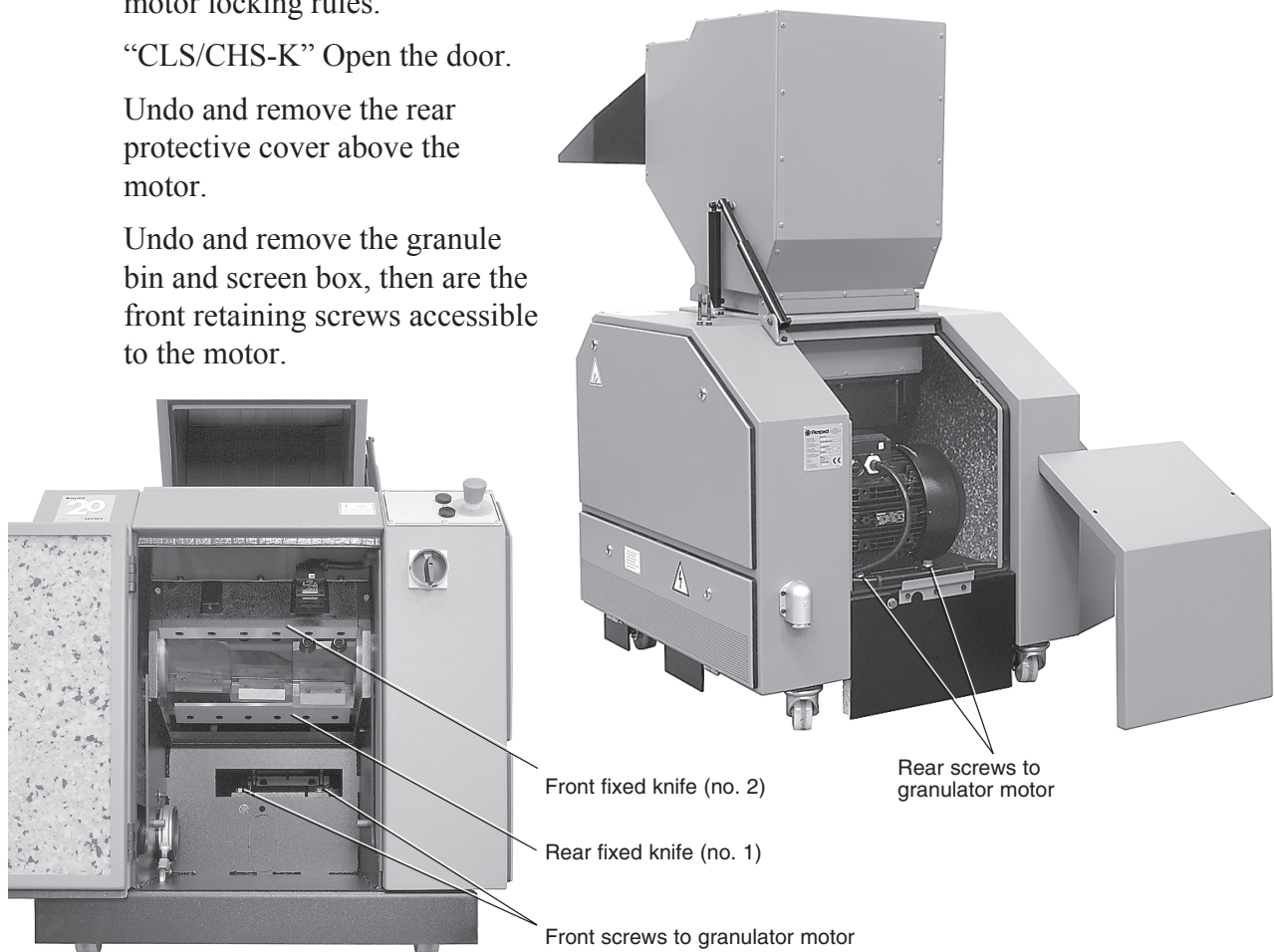

Screw M10 (key width 16 mm) tightening torque 40 Nm.

NOTE! Sign the executed inspection in the machine maintenance schedule.



5.5 20 - 30 hours after installation

1. Check the tension and condition of the drive belts after 20 to 30 running hours at normal load.

Checking and adjusting tension of the drive belts is described in chapter 7.3 “Transmission” in this instruction manual.

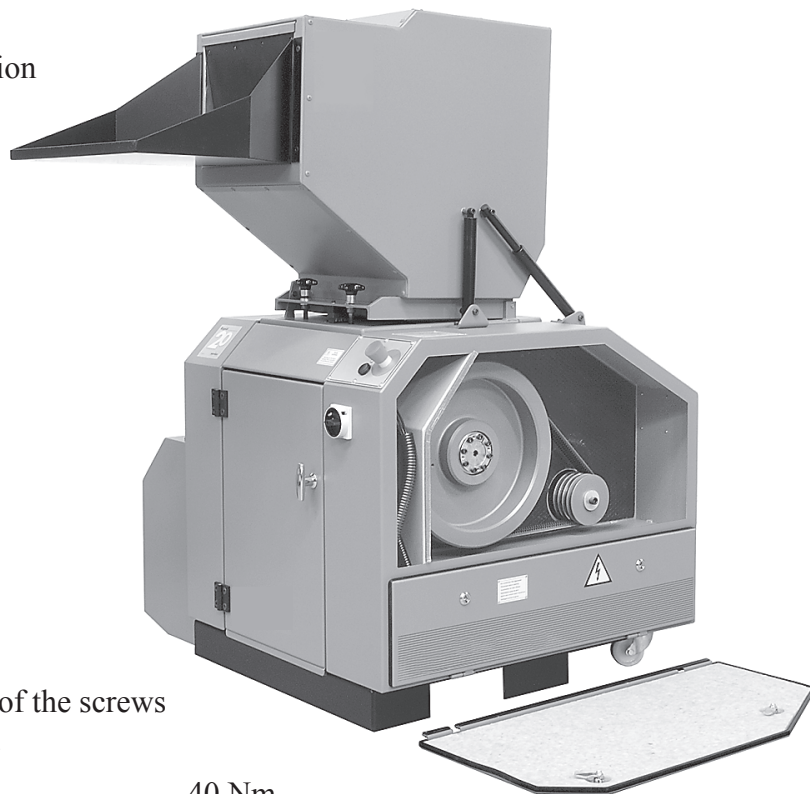

2. Check the tightening torque of the screws to the gas springs fastenings.

Tightening torque 40 Nm.

3. Check so that the granulator stands stable and in horizontal level.

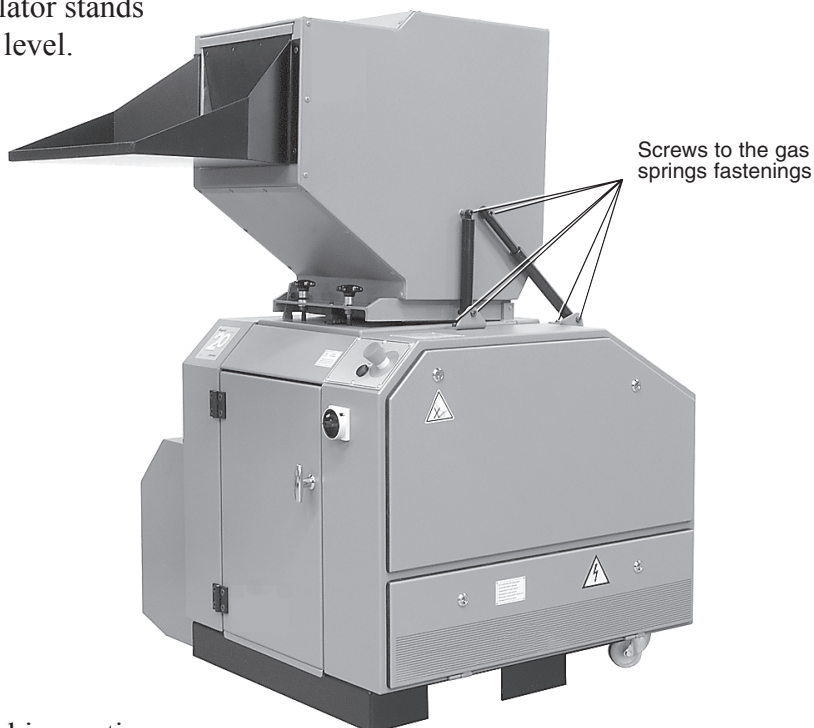

4. Make a thorough general inspection.

Ensure that there are no loose parts, screws, nuts or components on the machine.

Consult Conair Sales if there is any item that does not correspond to your expectations, or if there is any part of the machine that is faulty or that requires attention or repair.

NOTE! Sign the executed inspection in the machine maintenance schedule.



5.6 Opening of hopper, granule bin and screen box



Before opening of the hopper, granule bin and screen box, put/turn the granulator's main switch to position "0" Off.



Be careful when the knives are accessible, they are sharp and can cause personal injury.

Stop the granulator

1. Stop the feeding of material to the granulator.
Then wait until all material in the granulator are completely granulated.
The optional blower has emptied the granule bin and the material conveyance system from granulate.
2. Then stop the granulator, press the "Stop"- button.
3. Put, turn the main switch to position "0" Off.

Open the hopper

4. When the granular have a feed table, fold up the feed table.

When the granular is equipped with a band conveyor

- undo and remove the connector from granulator.
- fold the arm up, which controls 2 wheels on the stand of band conveyor.

Then can the band conveyor be moved away from granulator, to make the granulator free for cleaning, service etc.

5. Unscrew the star knobs "G" to the hopper "A".
6. Open pull/lift the tip catch "H" forwards so that it comes out of the opening.



NOTE! The hopper is counterbalanced with 1 or 2 gas springs, but hold the hopper at the same time, so that it does not fall out of control.

7. Open/fold the hopper "A" backwards.

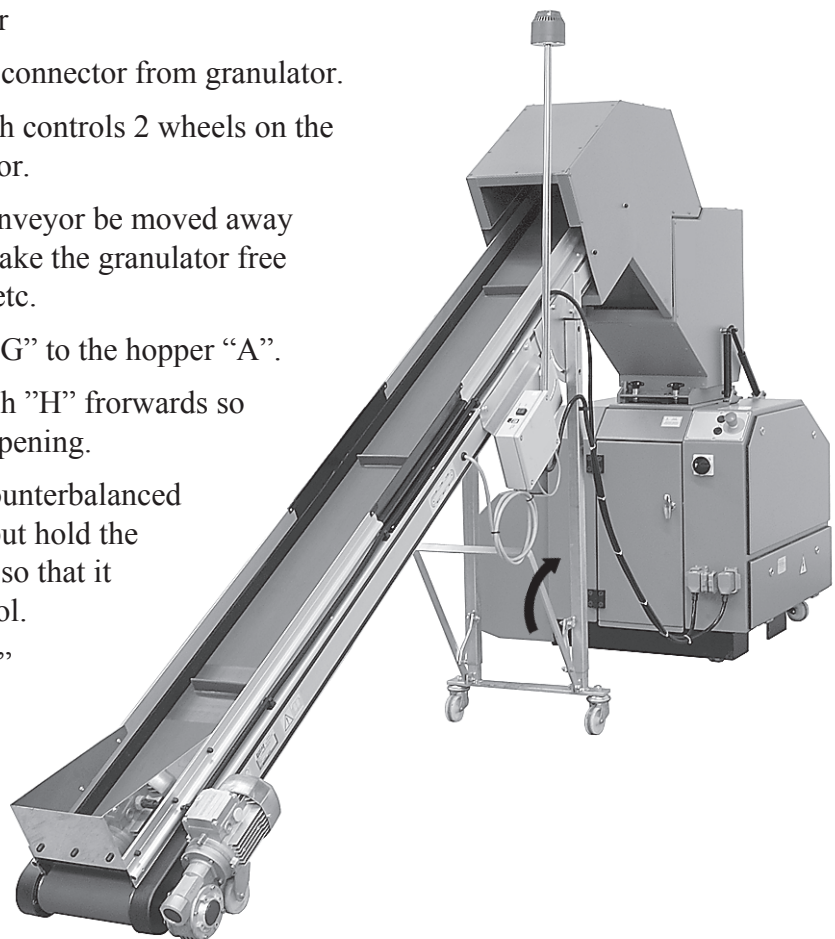
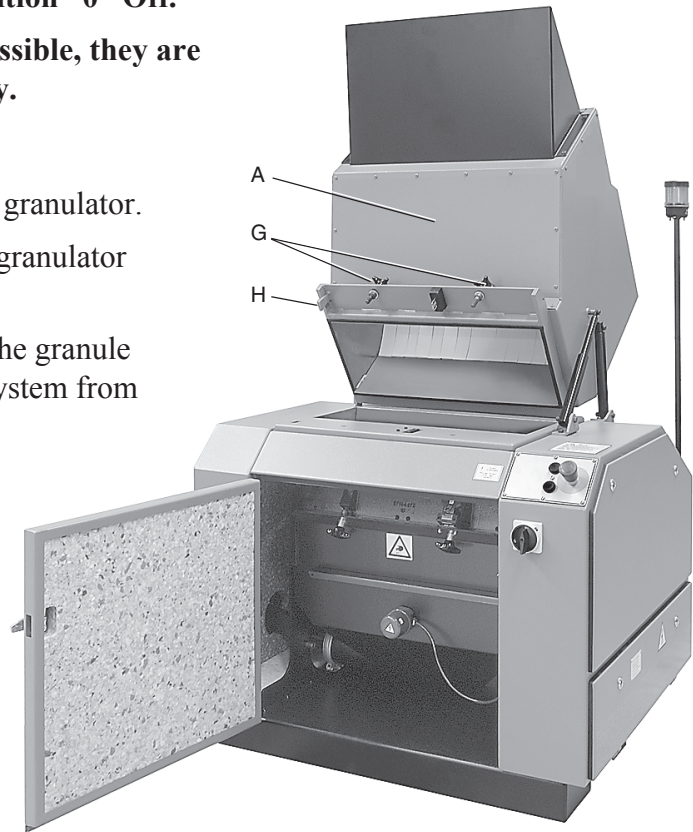

Open and remove the granule bin

8. Open the base sound enclosure door, if applicable 180°.
9. Undo and remove/pull out the out suction pipe "I" from left side on the granulator.
 - On CLS/CHS units with an optional blower undo and move the quick coupling ring from the outlet pipe stub "J" to the side.
 - Granulators which have a screen with the hole diameter 8 mm or larger, have an extend security. Unscrew the star knob to the granule bin.

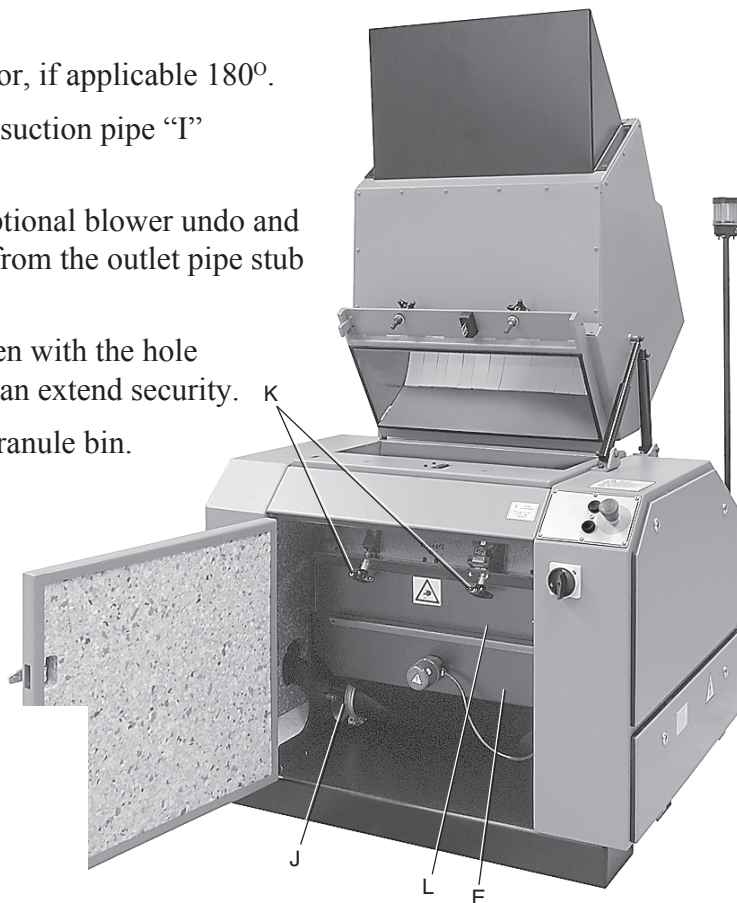
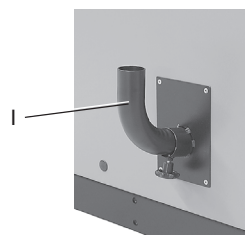

10. Remove, lift out and empty the granule bin "E".

Remove the screen box

11. Unscrew the star knobs "K" to the screen box "L".



NOTE! Hold the screen box at the same time, so that it does not fall out of control.

12. Fold down the screen box.

Changing of screen

The screen "M" is now accessible and can easily be lifted out, for to be changed or for cleaning.

5.7 Closing of screen box, granule bin and hopper



NOTE! Before closing, make sure that the mating surfaces are properly cleaned!
There is a pinch risk during closing, be careful.

Install the screen

1. Install the screen “M” in screen box.

Center and make sure that the cut-outs on the screen fits against the guide taps on the outer screen arches of screen box.

When installing a stitchreducing screen, install the screen as shown in the illustration.

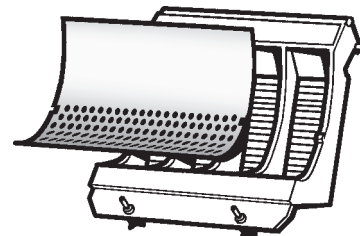

Install the screen box

2. Lift up and fasten the screen box “L” using the star knobs “K”, tighten the star knobs properly to stop.

Install the granulate bin

3. Install the granule bin “E” in the grooves on screen box, then push the granule bin properly in to stop.

When the granulator have a screen with the hole diameter 8 mm or larger, the granule bin should be equipped with an extend security and have an own star knob.

Screw the star knob properly in to stop.

4. Install the out suction pipe “I” from left side on the granulator.

On CLS/CHS units with an optional blower fit and fasten the outlet pipe stub using the quick coupling ring “J”.

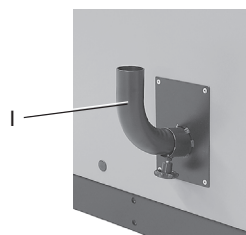

5. “CLS/CHS-K”
Close the door.

Close the hopper

6. Check and make sure that there are no granulate left on the surfaces or foldings which should meet each others during closing.
7. Close/fold the hopper “A” forwards.
8. Pull/lift the tip catch “H” forwards so that it falls in and down into the opening.

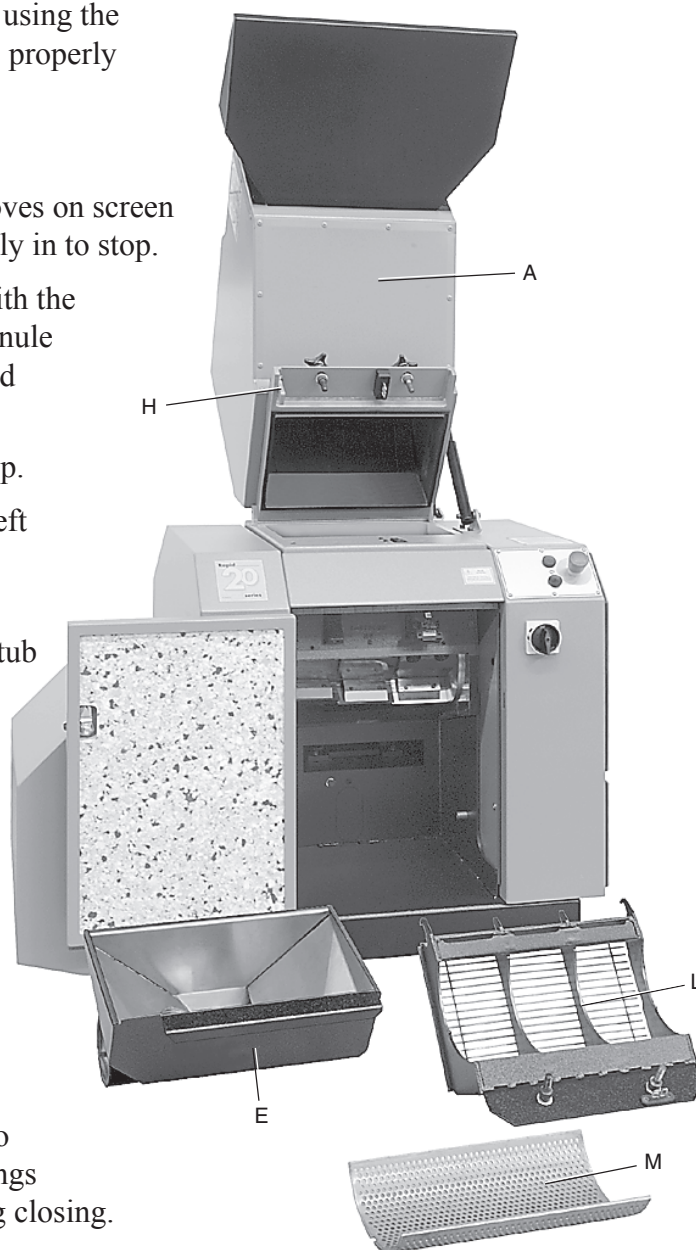

9. Fasten the hopper using the star knobs “G”.
Tighten the star knobs properly to stop.
10. When the granular have a feed table, fold the feed table down.

When the granular is equipped with a band conveyor

- move the band conveyor in tight against the granulator hopper. Then fold the arm down, which controls 2 wheels on the stand to band conveyor, until the sound trap on band conveyor rest on upper part of the hopper.
- connect the connector to granulator.

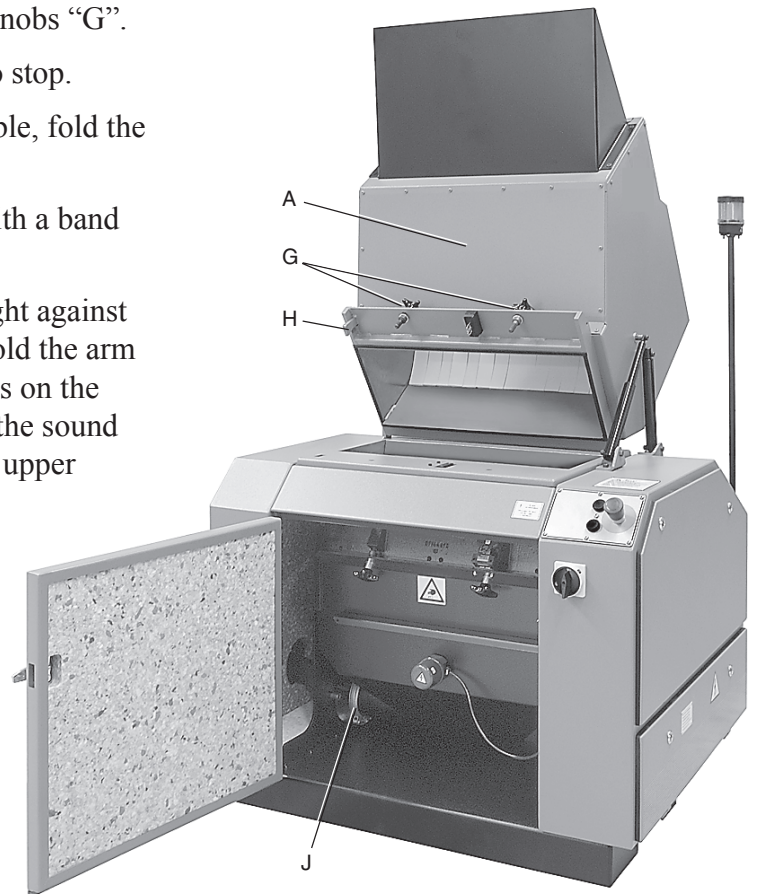

11. Put, turn the main switch to position “1” On.
12. Start the granulator, press the “Start”-button.



6. Operation and daily maintenance

6.1 Start and stop

The main switch is located direct under the control panel.

Starting and stopping is controlled by push buttons on the control panel.

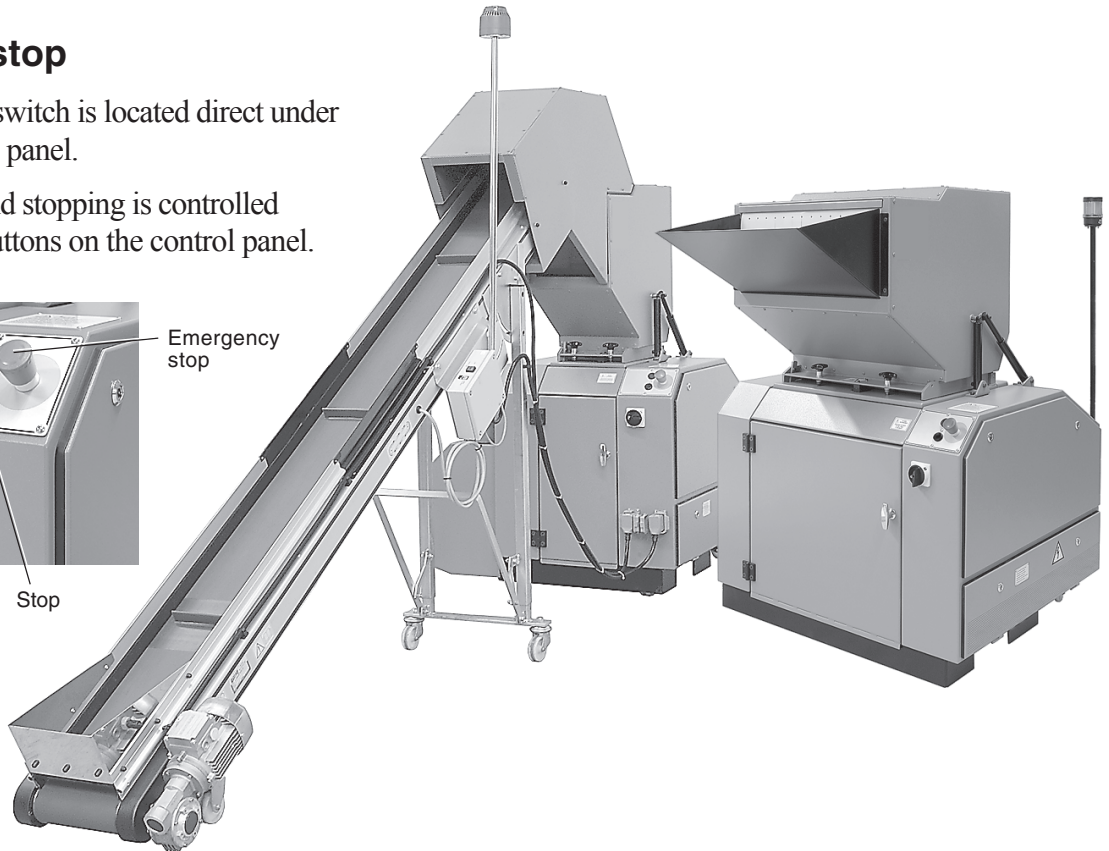
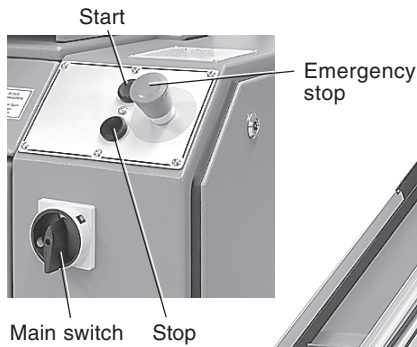

Start

Before start:

- Check that the hopper is properly closed and fastened by the star knobs.
- “CHS/CLS-K” Open the door and check that:
 - the screen box is properly installed and fastened by the star knobs.
 - the granule bin is emptied and properly installed, granulators which have a screen with a hole diameter 8 mm or larger:
 - check that the granule bin is properly installed and fastened by the star knob.

“CHS/CLS-K” Close the door.

- Put/turn the main switch to position “1” On.
- Check that the emergency stop is not activated.
- Start the granulator, press the “Start”-button.

Granulator with band conveyor.

If the band conveyor is used for warm plastic waste: Ensure that the warm plastic waste is deposited on the middle of the band, ie, uneven heating of the band could cause it to run askew.

Use ear protections and protective goggles

Conair recommends that ear protections are used during all granulation of plastics.

Grinding of hard plastic, big plastic details, or plastic lumps can cause high and dangerous sound.

Observe also that low sound levels during a long time are dangerous.

Conair recommends that protective goggles are used during all granulation of plastics.



Stop



- Stop the feeding of material to the granulator.
- **NOTE!** Then wait until all material in the granulator are completely granulated.

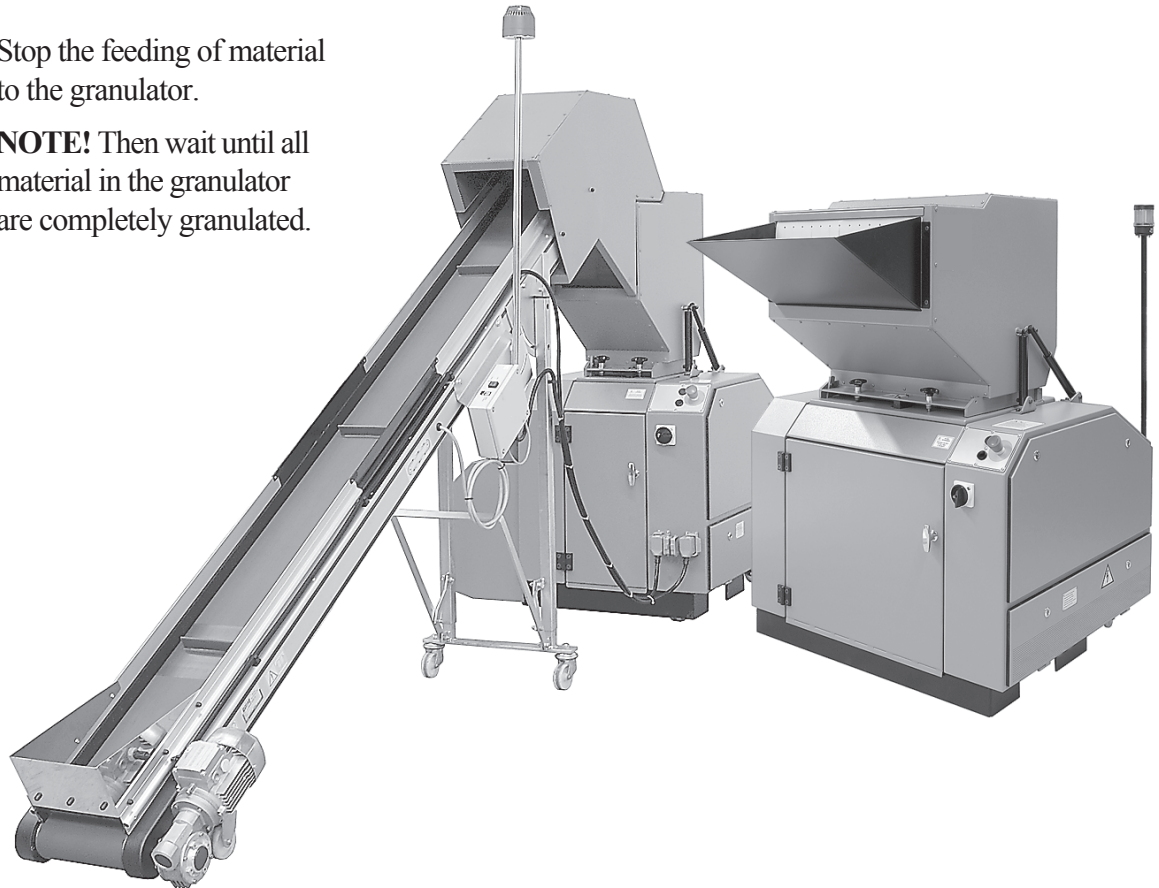

- Empty the granule bin, or wait until the blower “CHS/CLS-U” has emptied the granule bin and material conveyance system from granulate.



NOTE! If the granulator is stopped with material left in hopper, cutter house, granule bin (“CHS/CLS-U” blower and material conveyance system) the residual material will clog the cutter in the granulator (“CHS/CLS-U” blower and material conveyance system) during restart.

The granulator motor (“CHS/CLS-U” and the blower motor) will be overloaded and respective overload protection trips.

A manual cleaning of hopper, cutter house, screen, screen box, granule bin, (“CHS/CLS-U” blower and material conveyance system) are then necessary before restart.

- Stop the granulator, press the “Stop”-button.
- Put/turn the main switch to position “0” Off.



- Pull the connector out of the mains outlet.
- Press the emergency stop-button.

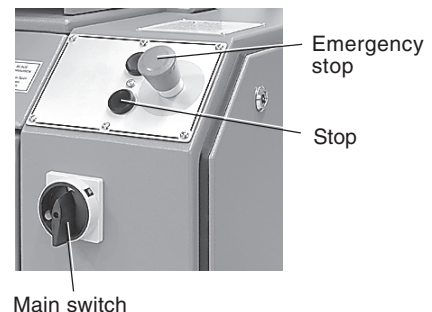

6.2 Inspection



There must be no plastic material left in the granulator when inspection is carried out.

NOTE! All servicing must be done by trained personnel in order to avoid personal injury and damage to the machine.

Daily inspection

1. Check that the granulator stands stable and level.
2. Check that the flaps in hopper are undamaged.

Replace damaged flaps at once.

Damaged flaps can drop down into the cutter house and damage the knives.

Damaged flaps also entail the risk of material ejection.

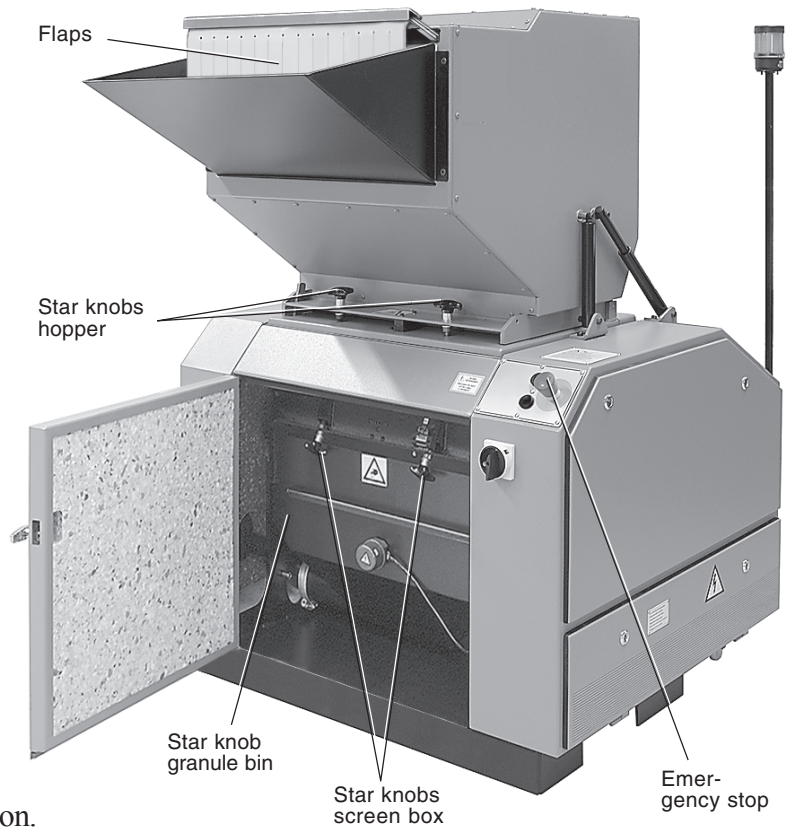

3. Check the emergency stop function.

Start the granulator and stop it with the emergency stop(s).

Reset, turn the button in the direction of the arrow (counterclockwise).

Weekly inspection

1. Check all the electric cables of the machine, for wear or other damage.
Replace damaged cables at once.
2. Check the function of the safety switches.

This granulator has in standard design 2 safety switches:

- 1 at the hopper, between the hopper and the cutter house.
- 1 at the screen box, between the screen box and the cutter house.

Additional 1 safety switch should be

at the granule bin, if the granulator have a screen with a hole diameter of 8 mm or larger.

Check the safety switch to the hopper:

- Undo the star knobs to the hopper a few turns and try to start the granulator.
- It should not be possible to start the granulator before the hopper is properly closed and the star knobs are properly tightened to stop.

Check the safety switch to the screen box.

- “CLS/CHS-K” Open the door.

- Undo the star knobs “K” to the screen box a few turns and try to start the granulator.
- It should not be possible to start the granulator before the screen box is properly closed and the star knobs are properly tightened to stop.

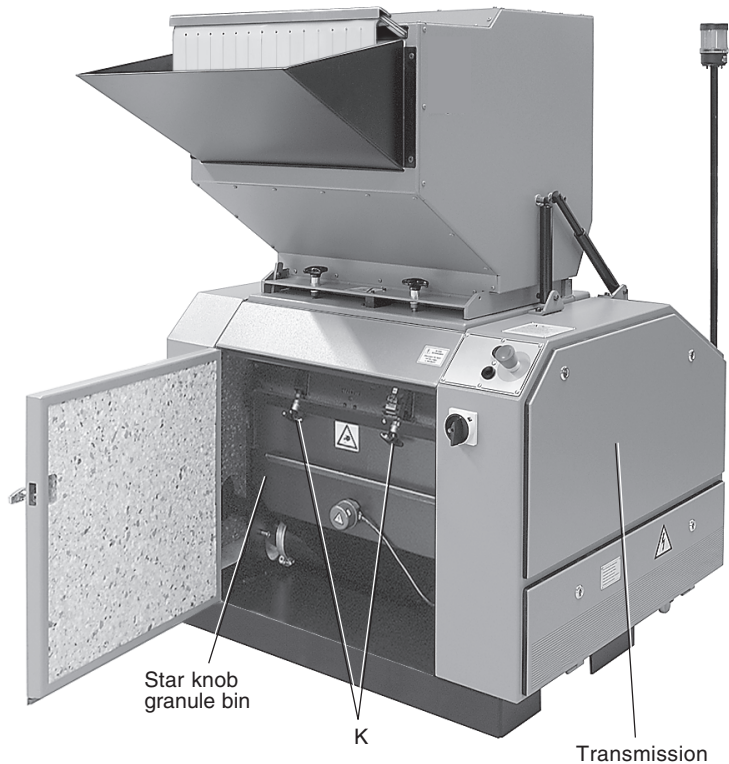

When the granulator has a screen with a hole diameter of 8 mm or larger, check the safety switch to the granule bin.

- “CLS/CHS-K” Open the door.
 - Undo the star knob to the granule bin a few turns and try to start the granulator.
 - It should not be possible to start the granulator before the granule bin is properly installed and the star knob is properly tightened to stop.
3. Check that the rotating and fixed knives in the granulator have sharp cutting edges.

The granulator must never be used with unsharpen knives to crush injection moulded, blow moulded or extruded plastic waste. Unsharpen knives causes an unnormal large wear which will seriously damage the granulator.



NOTE! Sign the executed inspection in the machine maintenance schedule.

Monthly inspection

1. The drive belts need to be checked each third month.

Check the condition of the drive belts, check that all drive belts are undamaged and not have any cracks, see chapter 7.3.



NOTE! Sign the executed inspection in the machine maintenance schedule.

Check every 6 month or at 1000 running hours

1. Check the tension and conditions of the drive belts after normal load, read chapter 7.3 “Transmission” in this instruction manual.
2. Check the tightening torque of the screws to the gas springs fastenings.
Tightening torque 40 Nm.
3. Check the tightening torque on the 4 screws which holds the granulator motor to the motor locking rules.

“CLS/CHS-K” Open the door.

Undo and remove the rear protective cover above the motor.

Undo and remove the granule bin and screen box, then are the front retaining screws accessible to the motor, see chapter 7.3.

Screw M10 (key width 16 mm) tightening torque 40 Nm.

4. Make a thorough general inspection.

Check so that there are no loose parts, screws, nuts or components on the machine.

5. Check general wear of the granulator.

Check the granulator inside and all functional parts.

Check also parts which not normally are subjected to wear.

6. Check the granulator's optional equipments.

Check the function and any general wear.

Consult Conair Service if there is any item that does not correspond to your expectations, or if there is any part of the machine that is faulty or that requires attention or repair.



NOTE! Sign the executed inspection in the machine maintenance schedule.

6.3 Stoppage and overloading of granulator



NOTE! Before any fault-finding, actions of mechanical faults and maintenance work.

Put/turn the main switch to position "0" Off. Then pull out the granulator's connector from the mains outlet. Press the emergency stop button.

Stoppage in cutter house

Cutter stoppage

If the granulator is overloaded so that the cutter has jammed.

Open the hopper carefully, then undo and remove the granule bin and screen box.

Opening see chapter 5.

Use a wooden piece/plank and carefully try to release the cutter in reverse rotational direction.

NOTE! Never use any metal objects to try and release a jammed cutter.



This can damage the cutter, knives, knife positions, support rules and cutter housing.

Clean the hopper, cutter house, screen box, granule bin and screen.

Overfilling in cutter housing

Look for and attend to the cause of overfilling in the granulator.

- Check the infeed and outfeed (blower, transport pipe, cyclone filter etc.).
- Check the knives and the knife clearance.

If the granulator knives are un-sharpened and blunt, or if the knife clearance is incorrect, this can cause overfilling in the cutter house.

Replace the knives and adjust the knife clearance, see chapter 7.

- Check the drive belts. If the tension of drive belts is too low, the transmission will slip and the cutter's rotational speed will drop too low, – this can cause overfilling in the cutter house.

Clean the hopper, cutter house, screen box, granule bin and screen.

Reset the granulator motor's overload protector in the electrical cabinet.

- Check the granulator's screen. The dimensions of the holes in the granulator's screen must be adapted to the material which are to be granulated, if the size of the holes is wrong can this lead to overfilling in the cutter house.

Contact Conair's local distributor or Conair's main office.

Hardened lumps in the cutter house, screen box and granule bin

If the cutter house, screen box, screen and granule bin are filled with compacted stiffened/hardened plastic.

Contact Conair's local distributor or Conair's main office.

By heat-treating the cutter house and screen box the plastic can be melted away.

In order to be able to apply heat treatment, the cutter house and the screen box must be removed from stand and enclosure.

This is work which can be carried out by Conair's service department at the head office.

A change of bearings is always necessary after heat treatment.

The granule bin must be replaced, because a granule bin filled with stiffened/hardened plastic can only be removed by means of cutting treatment.

Stoppage in hopper

Look for and take action to release the cause of the stoppage in hopper.

- The feed speed is too high or the pieces is too large.

Clean the hopper and lower the feed speed.

- The cutter house is overfilled.

Look for and take action to release the cause of overfilling in cutter house, see previous chapter.

“CLS/CHS-U” Stoppage in blower and material conveyance system

Look for and take action to release the cause of the stoppage in the blower and the material conveyance system.

- Check that the rotation direction of the blower is in accordance with the arrow on the blower hood.



NOTE! The blower blows even if the rotation direction is wrong, but capacity will be less than 25%.

- Check there is no stoppage in any transport pipes, the cyclone, the dust filter or the collecting container.

Clean and empty the transport pipes, the cyclone, the dust filter and the collecting container.

- Overfilling or stoppage in any transport pipes, the cyclone, the dust filter or the collecting container.

Clean and empty the transport pipes, the cyclone, the dust filter and the collecting container.

Smell of melted plastic and smoke formation

- Overfilling or stoppage in any transport pipes, the cyclone, the dust filter or the collecting container.

The blower is running easy and the granulator grinds plastic into powder and subsequently into a hot mass.



WARNING! If the granulator is shut off/stops, the result will be hardened lumps in the cutter house.



WARNING! Risk of fire in the cutter house.



NOTE! Do NOT shut off the granulator. Try to take action to release and evacuate the stoppage in the transport pipes, the cyclone, the dust filter or the collecting container.

Then clean and empty the transport pipes, the cyclone, the dust filter and the collecting container.

6.4 Cleaning

Clean when changing color, monthly or at least once every 300 hours of operation.



Always use protective goggles and protective gloves during cleaning!



WARNING! Granulate and plastic rests on the floor can cause risk of slipping!

Risk of slipping depending of granulate and plastic rests, is especially hazardous during cleaning, when the granulator is opened. Be careful!



Use a vacuum cleaner when cleaning the granulator.

Do not use compressed air and a blow nozzle.

Because then you must also clean the surroundings, after cleaning the granulator.



NOTE! Never use help when cleaning the granulator.

Carry out the cleaning alone and observe caution!

The risk of injuring fingers or hands increase if two or more persons are used to clean the granulator.

Read chapter 5. “Opening of hopper, screen box and granule bin” which describes how to open the granulator. Then follow the points below.



Be careful when the hopper and the screen box are opened.

The knives are then accessible, they are sharp and could cause personal injury.

1. Wait until the hopper is empty and all material in the granulator are completely granulated

“CLS/CHS-U” and the blower has emptied the granule bin and the material conveyance system from granulate.

2. Then stop the granulator, – press the “Stop”-button.

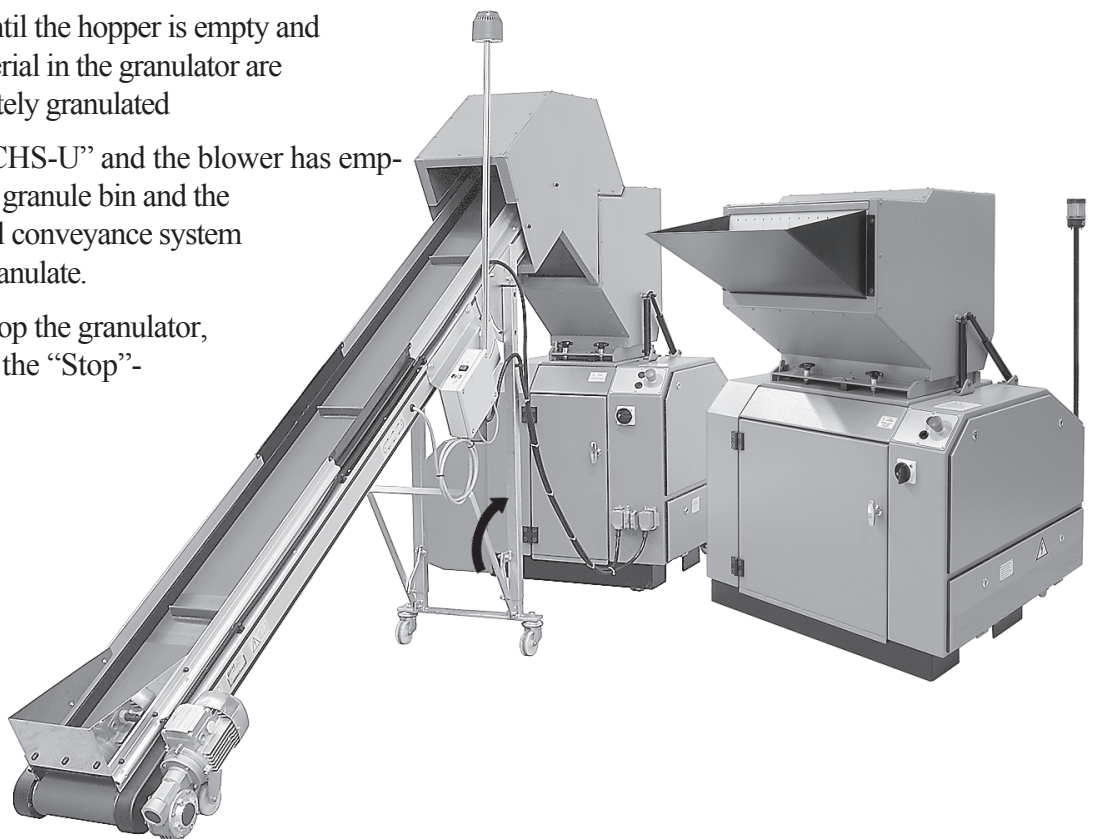

3. **Put, turn the granulators main switch to position “0” Off.**

4. When the granulator is equipped with a band conveyor:
 - undo and remove the connector from the granulator.
 - fold up the arm, which controls 2 wheels on the stand of band conveyer.

Then move the band conveyor away, so to make the granulator free for cleaning.

5. Lift out and clean the flaps “N”.
6. When the granular have a feed table, – fold up the feed table.
7. Unscrew the star knobs “G” to the hopper.
8. Open pull/lift the tip catch “H” forwards so that it comes out of the opening.
9. Open/fold the hopper “A” backwards.



NOTE! The hopper is counter-balanced with 1 or 2 gas springs, but hold the hopper at the same time, so that it does not fall out of control.

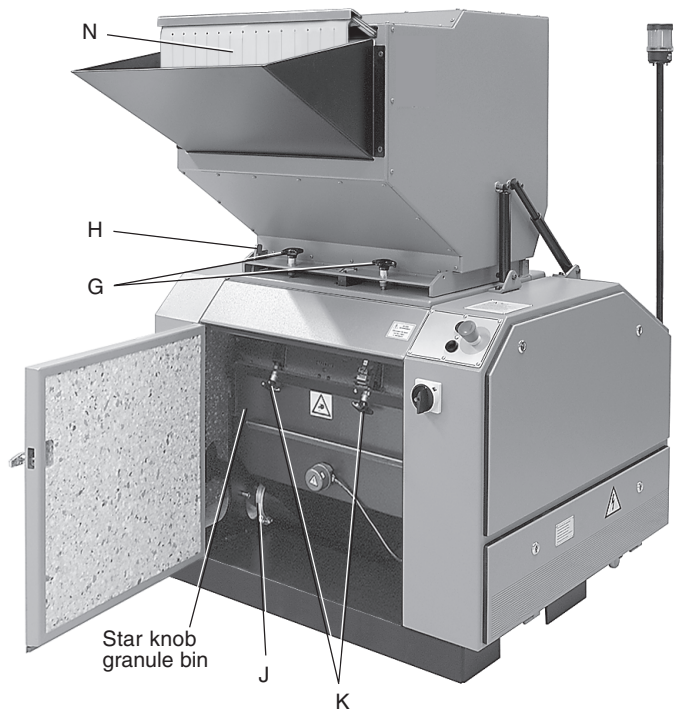

10. Clean the inside of hopper.
11. “CLS/CHS-K” Open the base sound enclosure door, if applicable (180°).
12. Undo and remove/pull out the out suction pipe “I” from left side on the granulator
 “CLS/CHS-U” Undo and move the quick coupling ring from the outlet pipe stub “J” to the side.
13. Remove, lift out and empty the granule bin “E”.
 – Granulators which have a screen with the hole diameter 8 mm or larger, have an extend security.

Unscrew the star knob to granule bin.

14. Clean in- and outside of the granule bin.
15. Unscrew the star knobs “K” to the screen box “L”.



NOTE! Hold the screen box at the same time, so that it does not fall out of control.

16. Fold down the screen box.
17. Lift out and clean the screen “M”.
18. Lift out and clean in- and outside of the screen box.

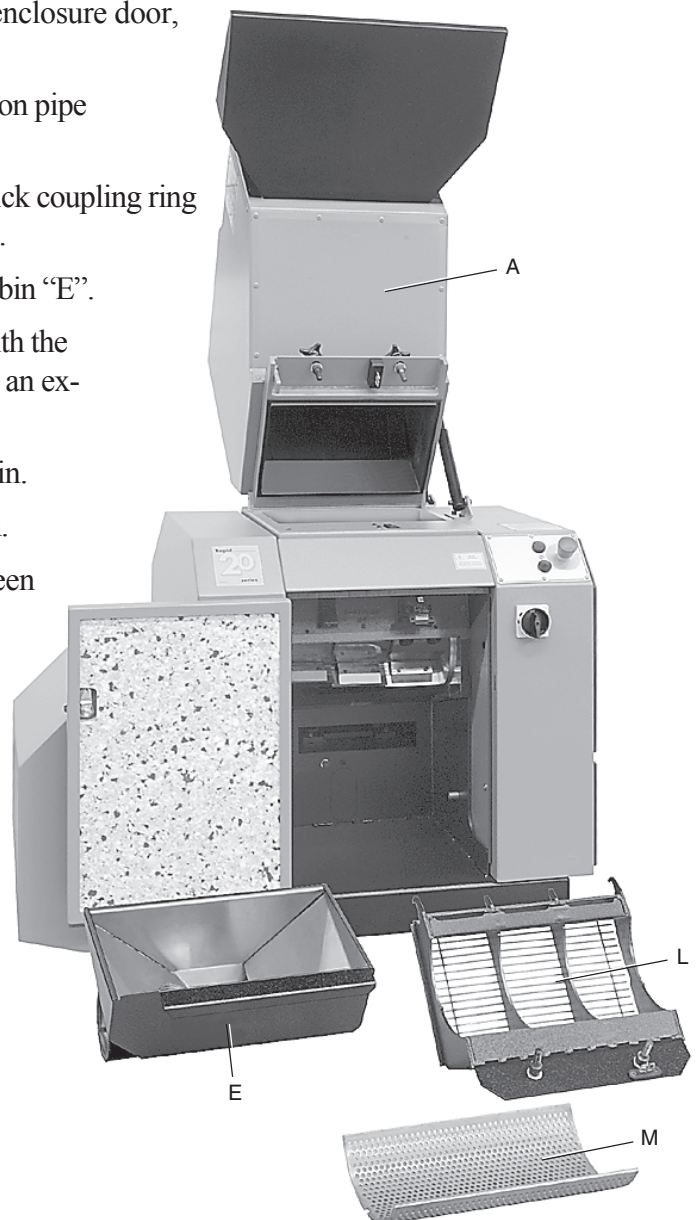
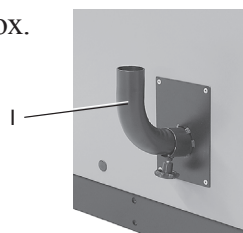

19. Clean the space between the side rings on cutter and the plummer blocks by:
 - Undo and remove the blue screws “O” 2 pcs.
 - Blow with compressed air in through the screw holes and rotate the cutter at same time least one complete turn.



NOTE! When the cutter is rotated manually, do this with great care!

The knives are sharp and can cause personal injury.



NOTE! Make sure so that no material are blown into the safety switches!

20. Replace the blue screws “O” to the cleaning holes.
21. Clean the in- and outside of the cutter house.
22. Clean the outlet pipe from granulator, the whole way from the connection at granule bin and out.

“CLS/CHS-U” Clean the inlet to the blower.



NOTE! It is important that there is no material left in the outlet pipe from granulator or in the inlet pipe to blower.

If plastic lumps or material are sucked into the blower at re-start, the blower can be so seriously damaged that it must be replaced.

23. “CLS/CHS-K” Clean the space insides the granulator encapsulating.
24. Clean any blower, the transport pipes and the cyclone.
25. Lift up and install the rear edge of screen box against the inner rear part of cutter house.
26. Install the screen in the screen box.

Center and make sure that the cut-outs on the screen fits against the guide taps on the outer screen arches of screen box.

Stitchreducing screen, install the screen as shown in the illustration.

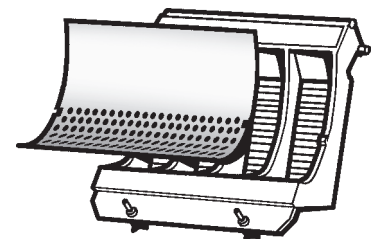

27. Lift up and fasten the screen box, tighten the star knobs properly to stop.
28. Install the granule bin in the grooves on screen box, then push the granule bin properly in to stop.

When the granulator have a screen with 8 mm hole diameter or larger, the granule bin have an extend security and a star knob, tighten the star knob properly in to stop.

29. Install the out suction pipe “I” from left side on the granulator.

“CLS/CHS-U” Fit and fasten the outlet pipe stub using the quick coupling ring “J”.

30. Close the hopper “A”. Check and make sure that no granulate are lying on the surfaces or foldings which should meet each others.

31. Pull/lift the tip catch "H" forwards so that it falls in and down into the opening.
32. Fasten the hopper, tighten the star knobs "G" properly in to stop.
33. "CLS/CHS-K" Close the door.
34. Replace the flaps "N" into the hopper.
35. Fold down the feed table.

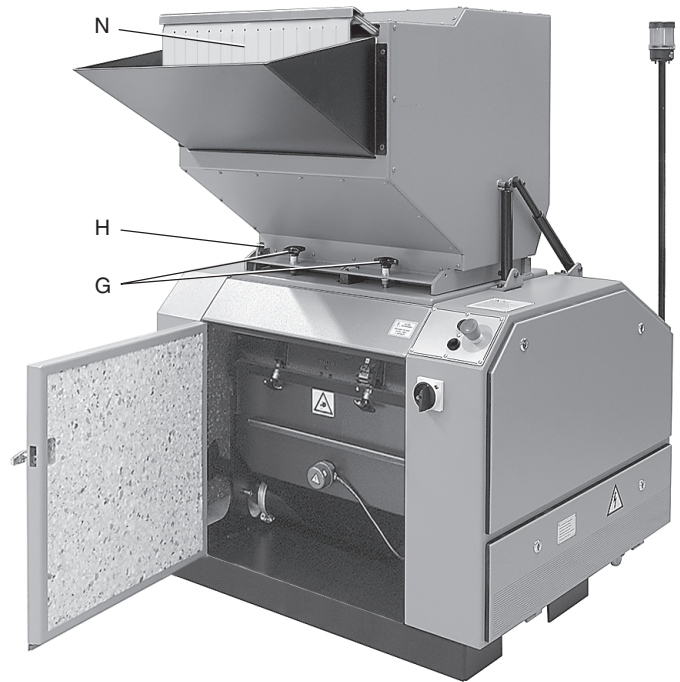

36. Clean the outside on the granulator.
37. Granulator with band conveyor.
 - Clean the transport belt, using a light cleaning agent.
38. Put, turn the main switch to position "1" On.
39. Start the granulator, press the "Start"-button.



6.5 Fault finding

The granulator does not start

- Check the main switch.

Put, turn the main switch to position “1” On.

- Check if the emergency stop is activated.

Reset, turn the button/-s in the direction of the arrow (counterclockwise).

- Check so that the hopper is properly closed.

Check so that the star knobs are properly tightened to stop.

- Check so that the screen box is properly installed and closed.

“CLS-CHS-K” Open the door.

Check so that the star knobs are properly tightened to stop.

- Check the granule bin.

The granule bin can be equipped with one additional safety switch.

“CLS-CHS-K” Open the door.

Check so that the star knob is properly tightened to stop.

- Check so that there not are any material in the hopper or cutter housing before start.

If there are any material in hopper or cutter house, the granulator cutter will be impeded at start. The granulator motor will be overloaded and the overload circuit breaker trips.

Check the overload circuit breaker “F1” for the granulator motor in the electrical cabinet.

If the overload circuit breaker trips shows “0” in the small window “P”.

Reset, press the knob “Reset” “R1”.

Clean the granulator before re-start.

- Granulator with blower “CLS-CHS-U”, – the granulator does not start, if the extraction blower not start.

Check the overload circuit breaker “F2” for the extraction blower motor in the electrical cabinet.

If the overload circuit breaker trips shows “0” in the small window “Q”.

Reset, press the knob “Reset” “R2”.

Check so that there are no material left in cutter house, granule bin or material conveyance system before start.

If there are any material in cutter house, granule bin or material conveyance system, the extraction blower motor will be overloaded and the overload circuit breaker trips.

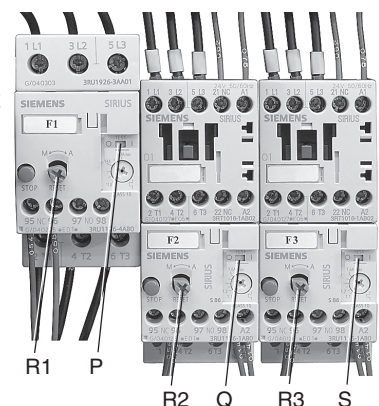
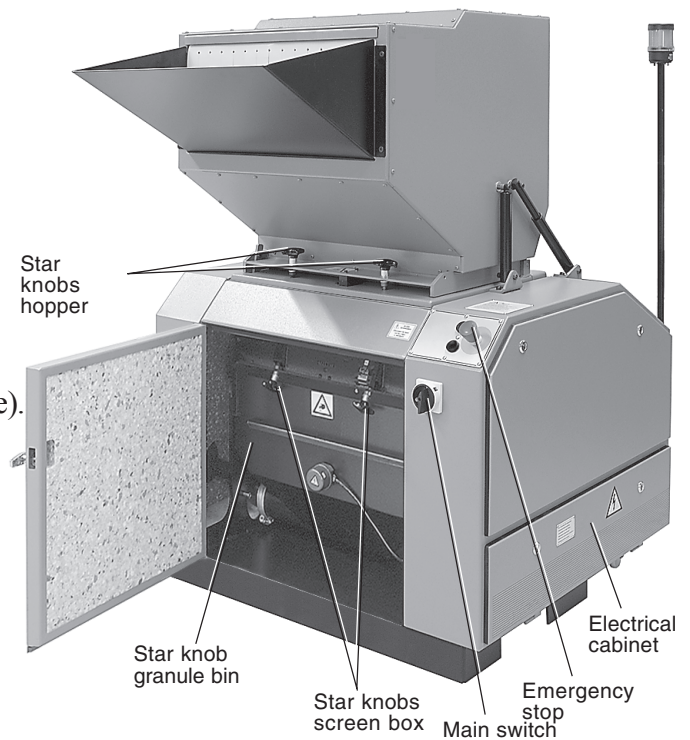

Clean the granulator, the granule bin and the material conveyance system and then re-start the granulator.

- Check the granulator knives and knife clearance.

If the granulator knives are unsharpened and blunt, or if the knife clearance is incorrect, this can result in stoppage. The granulator motor overload circuit breaker will trip.

Check the knives. Granulator with a 3-steps cutter, replace the knives, or adjust the knife clearance, see chapter 7 “Knife changing”.

Granulator with a open cutter, sharpen or replace the knives, or adjust the knife clearance, see next chapter.

The granulator stops for an unknown reason

- Check the overload circuit breaker for the granulator motor

The granulator motor has an overload circuit breaker, “F1” in the electrical cabinet, which trips if you jam or overload the granulator.

Check the overload circuit breaker “F1” for the granulator motor in the electrical cabinet.

If the overload circuit breaker trips shows “0” in the small window “P”.

Reset, press the knob “Reset” “R1”.

Clean the granulator before re-start.

- If the drive belts tension not is enough, the transmission will slip and the granulator motor overload circuit breaker “F1” trips.

Check and adjust the drive belt tension, see chapter 7.3 “Transmission”.

- At a bad in a in connection to a safety switch, the granulator stops.

Call for an qualified electrician for fault-finding and appropriate measures.

NOTE! Never bypass a safety switch.

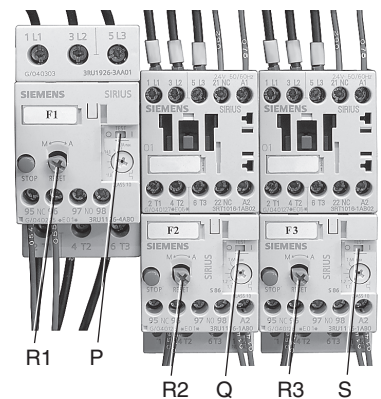

The granulator optional equipment does not start or stops for an unknown reason

- Check the main switch.
Put, turn the main switch to position “1” On.
- Check so that no emergency stop is activated.
- Check that the connector to band conveyor is connected to the socket on granulator.
- Granulator with band conveyor “CLS-CHS-KB”, if the conveyor does not start – check the overload circuit breaker for the band conveyor.

The band conveyor has an overload circuit breaker, “F3” in the electrical cabinet which trips, if you run to stop or overload the conveyor belt.

If the overload circuit breaker trips shows “0” in the window “S”.

Reset, press the knob “Reset” “R3”.

Clean and make sure that there is no material left on the conveyor belt before re-start.

- When the granule bin in granulator is equipped with a level monitor (paddle monitor).

The level monitor stops the granulator or the granulator's optional equipment, when the granulate level in the granule bin rises too high.

The level monitor can be connected to an acoustic alarm.

The level monitor's paddle should always rotate during operation

The sensitivity of the level monitor can be adjusted, read chapter 11.4 in this instruction manual "Setting the paddle monitor sensitivity".

- Granulator with current sensing relay, a granulator which is equipped with an current sensing relay, sense continuously the current consumption of the granulator motor and stops automatically the feeding of further material, when the granulator is running under heavy loading.

The current sensing relay have no reset.

The current sensing relay re-starts the granulator's feeding equipment/- optional accessories automatically, when the power consumption of granulator motor reduces.

The current sensing relay settings is shown in chapter 9.1 "Current sensing relay" in this instruction manual.



If the granulator or the optional equipment does not start after normal fault finding

Stop the granulator.

Put, turn the main switch to position "0" Off.

Press the emergency stop button.

Remove the connector to granulator out from the mains outlet.

Contact the person responsible for service and maintenance.

NOTE! All electrical maintenance must only be done by a competent electrician.

Check also the wiring diagram to the granulator, supplements and deviations may be applicable.

7. Service

All service must be carried out by trained personnel in order to avoid personal injury or damage to the machine.

7.1 Knife changing

Safety instructions and caution when changing knives

The following safety measures and cautions, should be followed when changing knives:



NOTE! Make sure that there never are any granulate or plastic rests on the floor during changing of knives.

WARNING! Granulate and plastic rests on the floor can cause risk of slipping!

If anyone slips or falls during changing of knives, or during handling of knives, it can cause serious personal injury!

WARNING!

NOTE! The granulator's cutter auto-rotates during removing or installing of rotating knives.

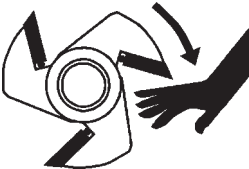

The cutter auto-rotates when the centre of gravity becomes unstable when knives are removed or installed.

Be therefore very careful during knife changing, so as not to injure fingers or hands.



OBSERVE! To ensure safety carry out knife changing alone. Always carry out knife changing alone to minimize the risk of injury to fingers or hands.

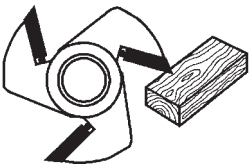

Block the granulator's cutter against the cutter house by using a strong block of wood, during removing or installing the screws with torque to rotating knives, so that the cutter not can rotate or glide.

Be careful when handling the knives, they are sharp and can cause personal injury.



Use always protective gloves during knife changing!



Each time the set of knives is changed, should the screws and the washers which retain the knives be replaced by new ones.

Every second time re-sharpened knives are installed should the screws and the washers which retain the knives be replaced by new ones.



At installing, install always all the rotating knives on the cutter, so that the cutter will be balanced.

Length, dimension and strenght class on screws and washers

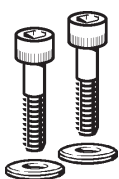

All the screws and the washers which retain the knives are of high strength class.

Only screws and washers supplied by Conair may be used for installing knives.

If not screws and washers from Conair are used, with correct length, dimension and strength class, Conair's responsibility and guarantee become invalid.

Tightening torque and torque wrench



It is very important that the knives are torqued to correct tightening torque.

All screws must be tightened using a torque wrench to the specified tightening torque which is stated in the instruction manual.

If a torque wrench is not used, or if screws are not tightened to the specified tightening torque which is stated in the machine's instruction manual, Conair's responsibility and guarantee become invalid.

Check the type of cutter house

Check which type of cutter housing your granulator have and how many fixed knives it is equipped with.

Standard cutter house with 3-step cutter

Cutter house with open cutter

3-step cutter with 3 rotating knives and 2 fixed counter knives. Open cutter with 3 rotating knives and 2 fixed counter knives.

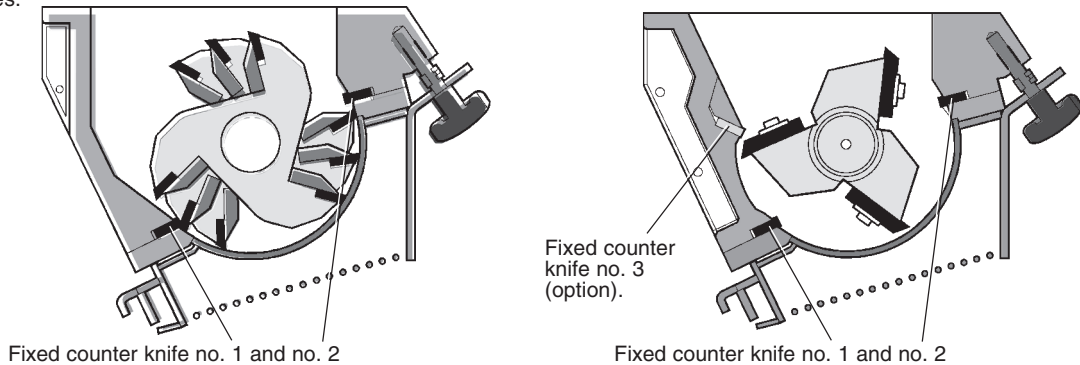

Conair's CLS-CHS granulator with "3-step cutter"



reflects a high technical level, and is manufactured with such a precision that all knives in the granulator can be installed in the cutter house, without any setting of knife clearances are needed.

NOTE! Both fixed and rotating knives!

All knives to granulators with 3-step standard cutter are of disposable type and are to be replaced when necessary.

Conair's CLS-CHS granulator with "Open cutter"

holds the same high technical level, but with the difference that the rotating knives must be pre-set before they are installed in the cutter house.

The rotating knives to granulators with open cutter can be re-sharpened.

Knife clearance

Knife clearance between rotating and fixed knives 0.15 - 0.25 mm.

Rotating knives

3-step cutter. The rotating knives are installed with screws (M10), washers and support rules.

Open cutter. The rotating knives are installed with screws (M16) and washers.

Tightening torque

3-step cutter 75 Nm.

Open cutter 220 Nm.

Knife positions

All knife positions in the cutter are fixed set at manufacturing, no adjustment may be done.

Pre-setting fixture

A pre-setting fixture to set the rotating knives to the open cutter is an option which not is included in the machine delivery, description see chapter 11.

Fixed knives

The fixed knives are installed with screws (M8) and support rules.

Tightening torque

Tightening torque, fixed knives 40 Nm.

Knife positions

All knife positions in the cutter house are fixed set at manufacturing, no adjustment may be done.

“Turn over”

The fixed knives are turn able and two cutting edges can be used before the knife are to be replaced.

The rear lower edge recommends as new cutting edge.

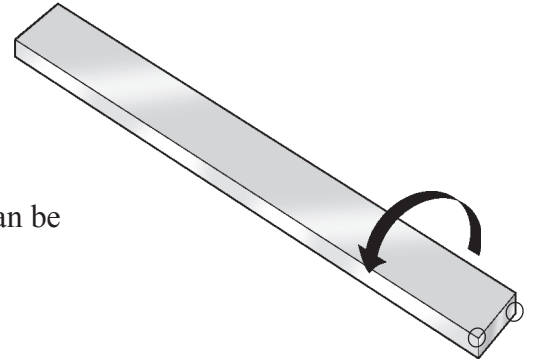

To change the knives

Noise encapsulated machine “CLS/CHS-K”, open the door.

Open the hopper.

Remove the granule bin, the screen box and the screen, – read chapter 5.

7.1.1 Removing of knives

Removing of rotating knives

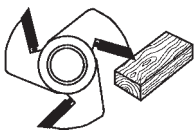

NOTE! For safety reasons, lock the cutter against the cutter house by using a strong block of wood, to avoid auto-rotation, when removing screws with torque.

NOTE! In the moment the cutter must be turned manually, do this with very great care!

The knives are sharp and can cause personal injury.



WARNING!

NOTE! Never try to stop a cutter by hand which is moving, even if the moving is slowly.

The cutter, cutter shaft and cutter belt pulley is together a very heavy unit. The energy of the cutter unit in motion is considerable.

The danger of injury to fingers and hands is very great.

1. Undo and remove the socket head screws “T” and the washers “U” which retains the rotating knives “B” (hex wrench 8 mm).

The knives are now loose.



NOTE! Hold the knife and the support rule, when the last screw to the knife undones and removes.

2. Lift out the support rules and the rotating knives.

NOTE! Be careful!

The cutter auto-rotates when the centre of gravity becomes unstable.

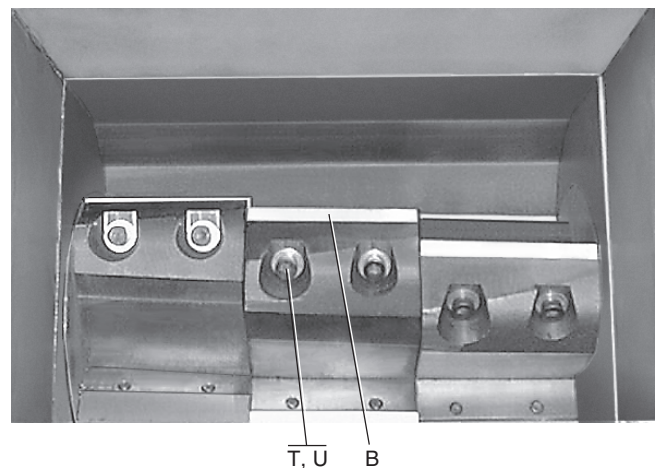

Removing of fixed knives

Fixed counter knife no. 1 (rear)

1. Undo and remove all the socket head screws “Y” (hex wrench 6 mm) which retains the support rule “X1” and the fixed knife “C1”.

The socket head screws which retains the support rule and the fixed knife, are undone from underneath the cutter house.



NOTE! Hold both the support rule and the fixed knife, when the last screw undones and removes, so that the knife and the support rule not falls out of control.



NOTE! The fixed knife and the support rule are heavy, be careful!

2. Remove the rear fixed knife “C1”.
3. Replace the support rule lightly using all screws.

Fixed counter knife no. 2 (front)

1. Undo all the socket head screws “Y” (hex wrench 6 mm) which retains the support rule “X2” and the fixed knife “C2” a few turns.

The socket head screws which retains the support rule and the fixed knife, are undone from underneath the cutter house.



NOTE! Hold the fixed knife when the last screw to the support rule undones so that the knife not falls out of control.



NOTE! The fixed knife is heavy, be careful!

2. Remove the front fixed knife “C2”.

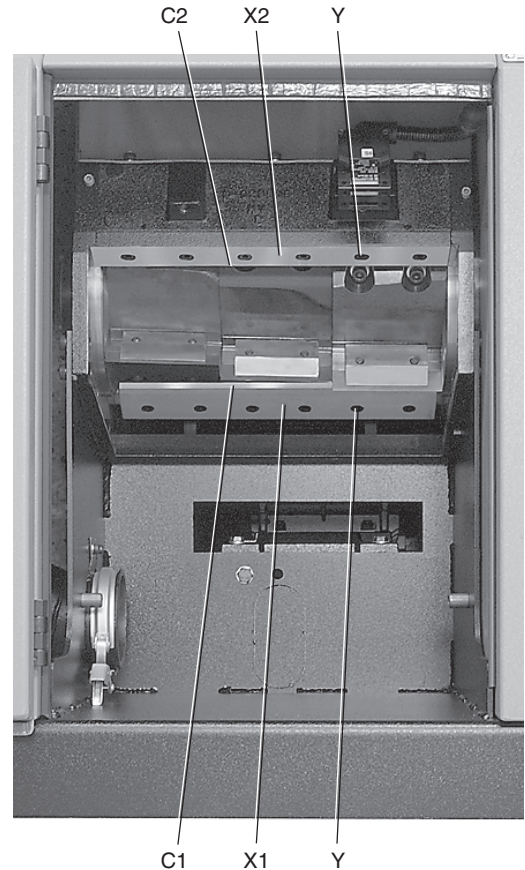



7.1.2 Installation of knives

Tips for installation of knives



Mark each knife, with a felt-tip pen when each task is carried out:



-  = The knife is installed with a light tightening torque and the rear edge is properly pressed in against the knife position.
-  = The knife screws are torqued to the correct torque.
-  = The knife clearance has been re-checked and is correct.

During installation of pre-set knives “Open cutter”:

Mark each knife, with a felt-tip pen when each task is carried out:

-  = The knife clearance is correctly set in the pre-setting fixture.
-  = The knife is installed and the screws are torqued to the correct torque.
-  = The knife clearance has been re-checked and is correct.

Clean all knife positions

Clean all knife positions.

All knife positions must be free from dirt, rests of granulate, grease and oil.

Clean all knives

Clean all knives.

All knives must be free from dirt, rests of granulate, grease and oil.

Use protective gloves



Use always protective gloves during knife changing! The knives are sharp and can cause personal injury.

New screws and washers should be used at every second installation

Granulator with 3-step cutter.



At every second changing the set of knives, should the screws and the washers which retain the knives be replaced by new ones.

Granulator with open cutter.

Each time the set of knives and every second time re-sharpened knives are installed, should the screws and the washers which retain the knives be replaced by new ones.

First install the rear fixed counter knife (no. 1)

1. Install the knife "C1" in the knife position.
2. Screw in the socket head screws "Y" until the support rule "X1" lightly supports the knife.
3. Press the knife properly into the knife position to stop.



NOTE! The screws in the rear of the knife position is permanent glued.



NOTE! The knife have a fixed measure and no adjustment may be done.

4. Tighten the screws "Y" with an alternated increased torque to 40 Nm.

Install the rotating knives



When installing rotating knives, install always all the rotating knives on the cutter, so that the cutter becomes balance.



NOTE! When installing rotating knives in a granulator with open cutter, the knives must be pre-set before the installation!

The pre-setting of knives to a granulator with open cutter is done in a pre-setting fixture. The fixture is not include in the machine delivery but it is a very practical accessorie, read chapter 11.

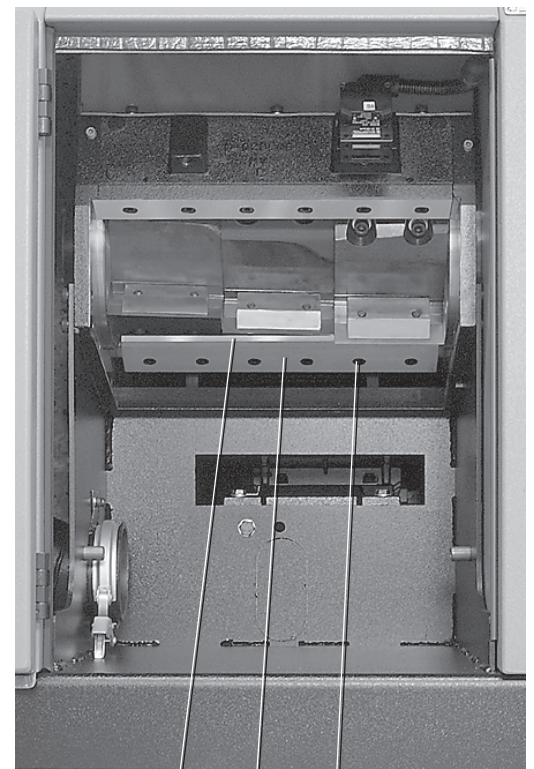

C1 X1 Y

1. Install all the rotating knives “B” in the knife positions on the cutter with screws “T” and washers “U” so that they lightly fasten the knives.



NOTE! The setting screws in the knife positions on cutter are permanent glued. The settings of the screws must never be changed!

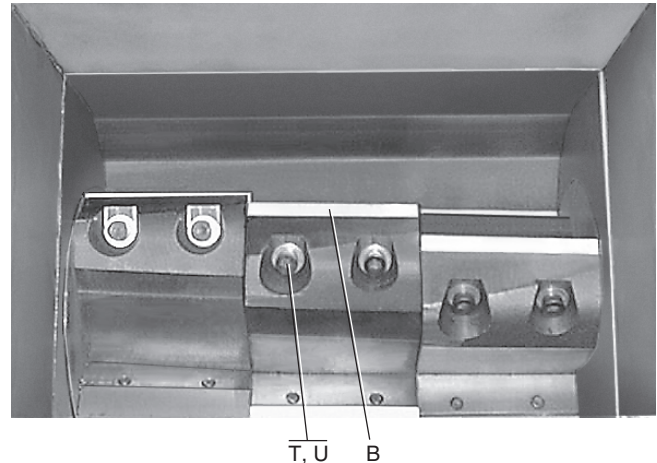

2. Press the rotating knives “B” with force properly into the knife positions to stop.

3. Tighten the screws with an alternated increased torque to 75 Nm.
Granulator with open cutter – tighten the screws with an alternated increased torque to 220 Nm.
4. Check with care so that all the rotating knives freely can pass the rear fixed counter knife.

If any rotating knife not freely can pass – undo the screws to the knife and then press the rotating knife with more force properly in into the knife position to stop.

Then fasten the knife with correct tightening torque.

5. Then check the knife clearance using a feeler gauge, the clearance should be 0.15 - 0.25 mm.

Check the knife clearance for each specific rotating knife against the rear fixed counter knife, check at the outer edges of the knife.

Then install the front fixed counter knife (no. 2)

1. Install the front fixed counter knife “C2” in the knife position.
2. Screw in the socket head screws “Y” until the support rule “X2” lightly supports the knife.
3. Press the knife properly into the knife position to stop.



NOTE! The screws in the rear of the knife position are permanent glued.



NOTE! The knife have a fixed measure and the settings of the screws must not be changed!

4. Tighten the screws “Y” with an alternated increased torque to 40 Nm.
5. Check with care so that all the rotating knives freely can pass the front fixed counter knife.

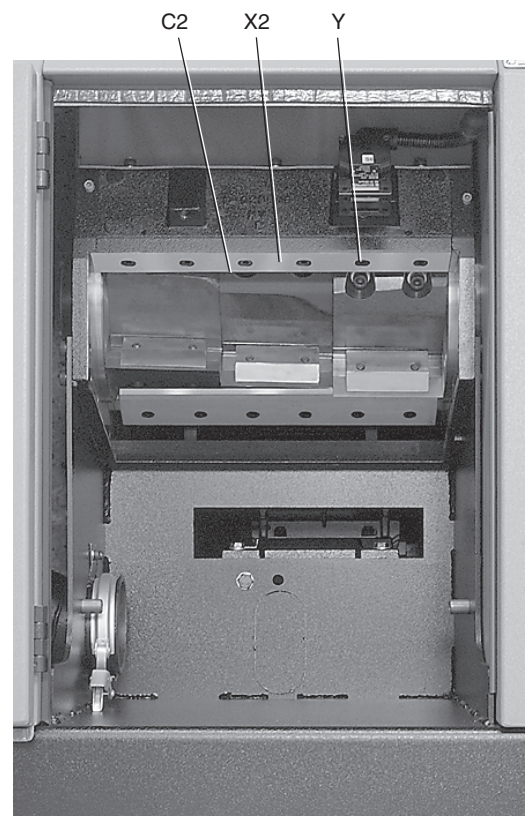

Then install possible third fixed counter knife (no. 3)

Installing, see chapter 11.

Check the knife installation

1. Check carefully, that all the rotating knives freely can pass all fixed counter knives, rear counter knife, front counter knife and possible third fixed counter knife (option).

If any rotating knife “B” not freely can pass the rear fixed counter knife “C1”.

Undo the screws “T” to the knife and then press the rotating knife with more force properly in into the knife position to stop.

Then fasten the knife with correct tightening torque.

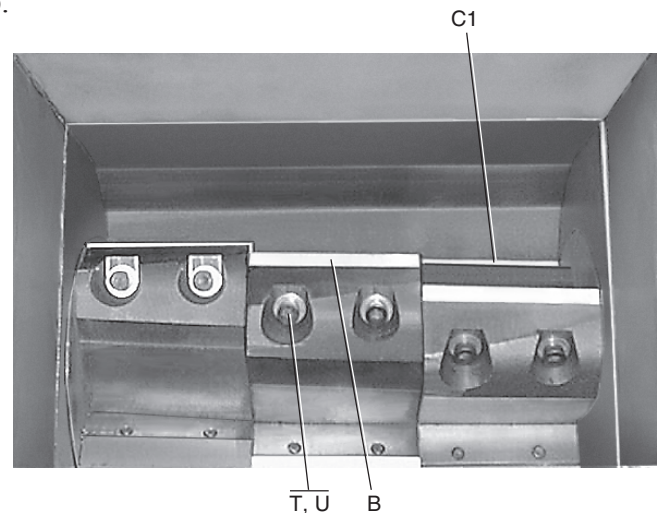

2. Re-check the knife clearance for each specific rotating knife against the rear fixed counter knife.

Use a feeler gauge, the clearance should be 0.15 - 0.25 mm, check at the outer edges of the knife.

3. Re-check the tightening torque of all retaining screws to all rotating knives (75 Nm; granulator with open cutter 220 Nm.).
4. Re-check the tightening torque of all retaining screws for both rear, front and possible third fixed counter knife (40 Nm).



NOTE! Sign the executed knife changing in the machine maintenance schedule.

2 - 4 hours after knife changing

1. Check the tightening torque of all retaining screws to all rotating knives.
2. If the tightening torque for any screw to any of the rotating knives is changed, must also the knife clearance for this knife be re-checked.



NOTE! Sign the executed re-check of knife changing in the machine maintenance schedule.

7.2 Grinding of knives

Observe! Only the rotating knives to granulators with the open cutter can be grinded.

All knives must be grinded precisely, so that the correct cutting- and relief angles are received. Otherwise the granulator loses its efficiency.



Be careful during handling of knives!

Knives are sharp and can cause personal injury.



Only grind the marked surfaces and respect the specified measures!

NOTE! Conair's knives are made from hardened steel.



Hardened steel knives are brittle and can crack if they are dropped or handled carelessly.



Grinding of hardened knives requires knowledge, let therefore a craftsman with experience carry out grinding of knives.

Cool the knives during grinding

Heat is developed during grinding, the knives must therefore be cooled during grinding. Knives which during grinding are exposed to excessive heat, are burned or blued, lose their hardness, strength and durability.

Knives which are burned, blued, or exposed to excessive heat, can not be repaired by grinding away the blued or burned colour.

Blued or burned knives are useless.

Grinding fixture (option).

For granulator CLS/CHS models use the Conair's grinding fixture art.no. 3-30324

With the grinding fixture and a surface grinder with magnetic table, can the rotating knives be grinded so that they receive correct cutting- and relief angles.

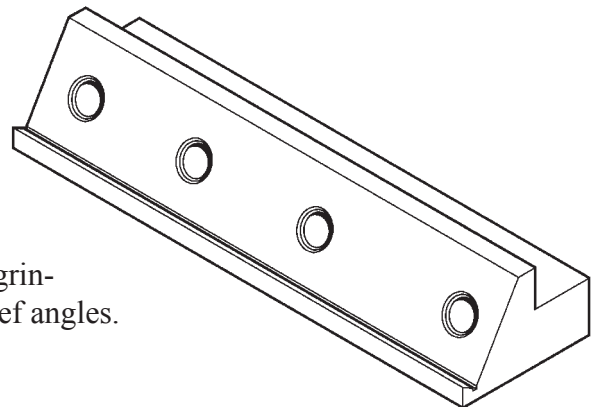

First grind the relief angle

First grind the relief angle.

Grind the relief angle until there are no uneven spots on the knife edge.



Cool the knives during the grinding, grind slowly and make sure that no heat is generated.

NOTE! If a knife is burned or blued, it is useless.

Then grind the cutting angle on the knife edge

When the relief angle has been ground and there are no uneven spots on the knife edge, you can grind the cutting angle on the knife edge. The knife is "sharpened" and given a knife edge in new fresh steel.



Cool the knives during the grinding, grind slowly and make sure that no heat is generated.

NOTE! If the knife edge is burned or blued is the knife useless.

Grinding of rotating knives – granulator with open cutter

The rotating knives consist of a set of several knives.

Keep the complete set of knives together, as one unit.

Balancing

The cutter in the granulator is balanced during manufacturing. To retain balance in the cutter, all the rotating knives must have exactly the same weight.

All rotating knives in a set of knives must therefore be ground exactly the same. All the knives must after grinding have the same weight, to within a gramme.

Follow the instruction and use grinding fixture and surface grinder with magnetic table, to make the rotating knives exactly the same, with weight, and correct cutting and relief angles.

Grinding

Grind the worst knife first.



First grind the relief angle on the worst knife

Relief angle 35° .

- Install the knife in the fixture as shown in the illustration, together with the spacer which belongs to the grinding fixture.

The spacer should be under the rear of the knife, see illustration.

- Fix the knife, use the screws and the spherical washers which belongs to the grinding fixture.
- Grind the relief angle until the knife edge does not have any irregularities.
- **NOTE! Retain the settings on the surface grinder** and grind the relief angles on **all the rotating knives** exactly the same.

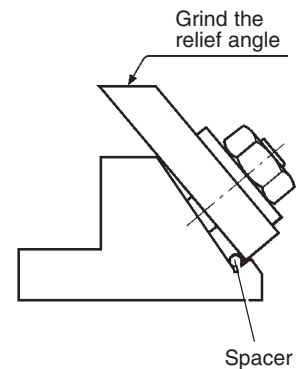

Grind the cutting angle on the knives

Cutting angle 30° .

- Install the knife in the fixture as shown in the illustration, without the spacer under the rear of the knife.
- Fix the knife, use the screws and the spherical washers which belongs to the grinding fixture.
- Grind the knife's cutting angle until the knife edge is exactly 3 mm wide.

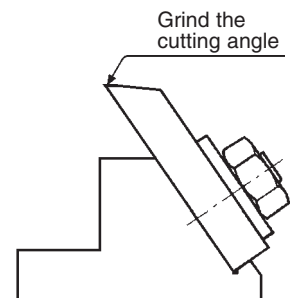

- **NOTE! Retain the settings on the surface grinder** and grind the cutting angles on **all the rotating knives** exactly the same.

Minimum knife dimensions

- The knives can be ground down to the dimensions in the adjacent illustration.

After that, the knives are used up and must be replaced by new ones.

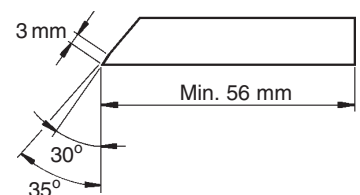

7.3 Transmission

Inspection and adjustment of drive belts

The machine is driven by 3 or 4 V-belts, depending of motor size.

Inspection of drive belts



WARNING! Pinch risk between pulleys and drive belts.

For to check the drive belts

- Open and lift off the upper door from right hand side of the granulator.

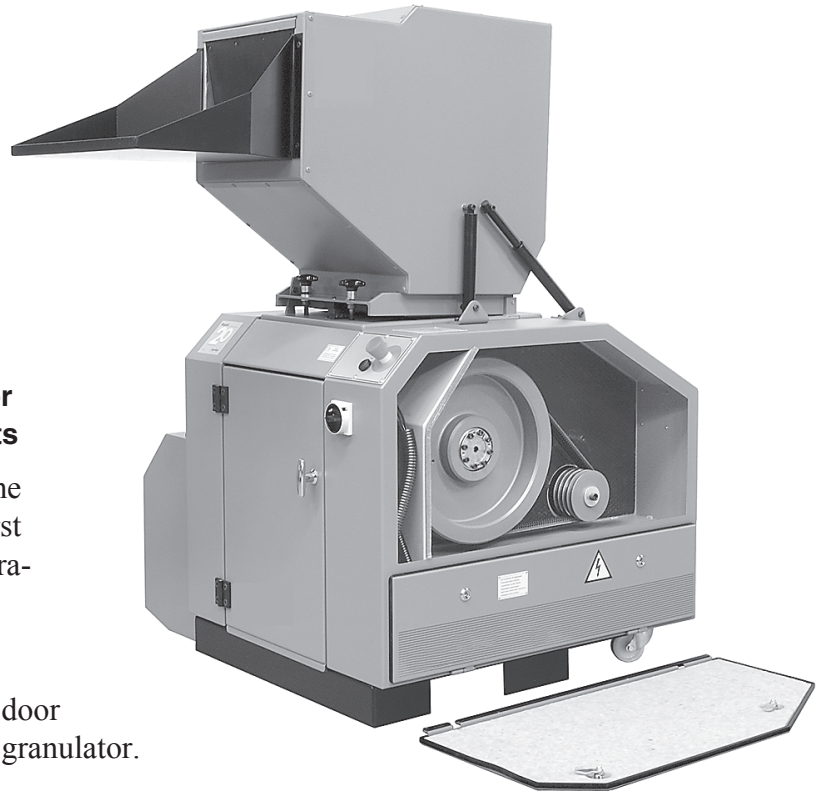

First time after installation or installation of new drive belts

The tension and condition of the drive belts must be checked first time after 20 - 30 hours of operation at normal load.

Check every three months

- Open and lift off the upper door from right hand side of the granulator.
- Rotate the drive belts a few turns.
- Check that all drive belts are intact, undamaged and does not have any cracks.



NOTE! Sign the executed inspection in the machine maintenance schedule.

Check every 6 months or at 1000 running hours.

The tension of the drive belts should be checked every 6 months or at 1000 running hours.

- Open and lift off the upper door from right hand side of the granulator.
- Rotate the drive belts a few turns.
- Check that all drive belts are intact, undamaged and does not have any cracks.
- Check belt tension by loading the V-belts and measure the deflection at same time.

The loading (in Newton) is determined by the size of the granulator motor.

- Check the motor size; kilowatt (kW) on the type plate on the motor.
- Load each one of the V-belts centrally between the cutter and motor pulley and measure the deflection

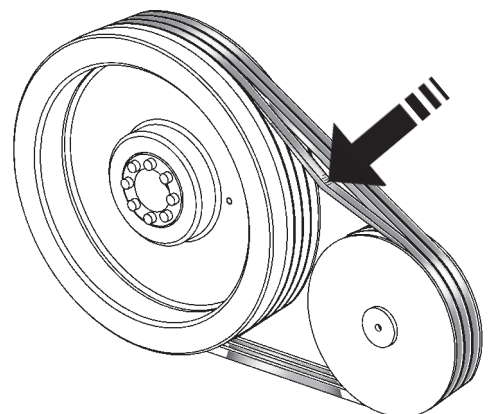

Motor 5 Hp, {4.0 kW}; 7.5Hp, {5.5 kW}; 10 Hp, {7.5 kW}:

Load each one of the V-belts with approx 20 N, midway between the motor and cutter belt pulleys.

At 20 N's load it should be possible to deflect the V-belt max. 5 mm.

Motor 15Hp, {11 kW}:

Load each one of the V-belts with approx 27 N, midway between the motor and cutter belt pulleys.

At 27 N's load it should be possible to deflect the V-belt max. 5 mm.



- Adjust when necessary.

NOTE! Sign the executed inspection in the machine maintenance schedule.

Adjustment of drive belts

- “CLS/CHS-U” Open the door.
- Undo and remove the rear protective cover above the motor.
- Undo and remove the granule bin and screen box, then are the front screws to the motor accessible.
- Check the tension of the drive belts and adjust when necessary.

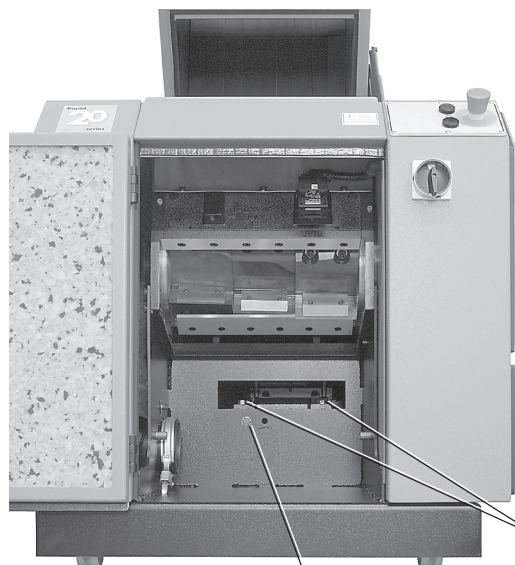

Front adjustment screw to the granulator motor

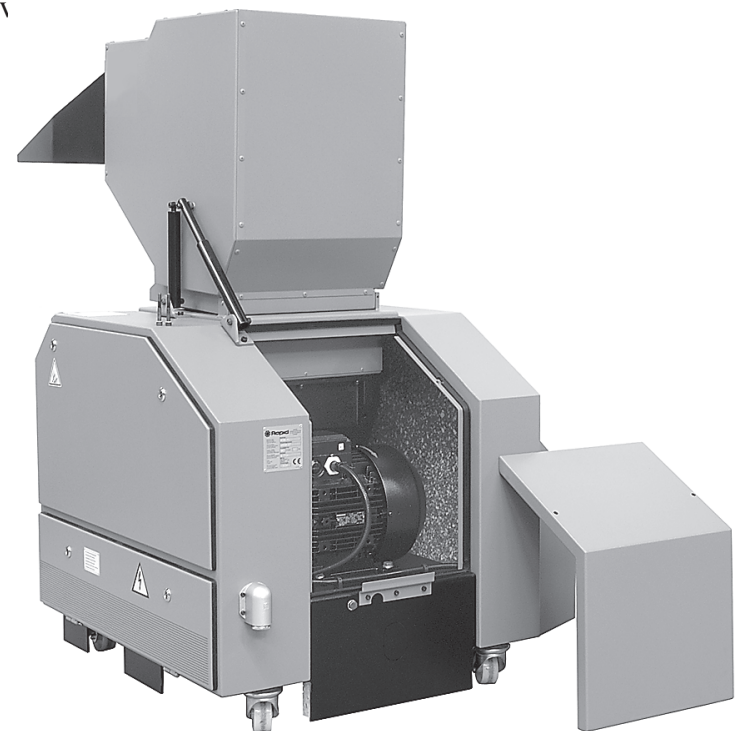

Rear adjustment screw to the granulator motor

Rear screws to the granulator motor

Front screws to the granulator motor

- Undo the screws which retains the granulator motor to the motor locking rules a few turns 4 pcs.
- Adjust the drive belt tension by increasing/reducing the distance between the motor and the cutter belt pulley, using the motor adjustment screws 2 pcs (front and rear).

NOTE! It is important that the motor pulley and the cutter belt pulley lines up!

Unscrew the front adjustment screw to the motor locking rule.

Tighten the rear adjustment screw to the motor locking rule the same number of turns which the front adjustment screw was unscrewed.



- Rotate the cutter belt pulley with the drive belts a few turns.
- Check the tension of drive belts.

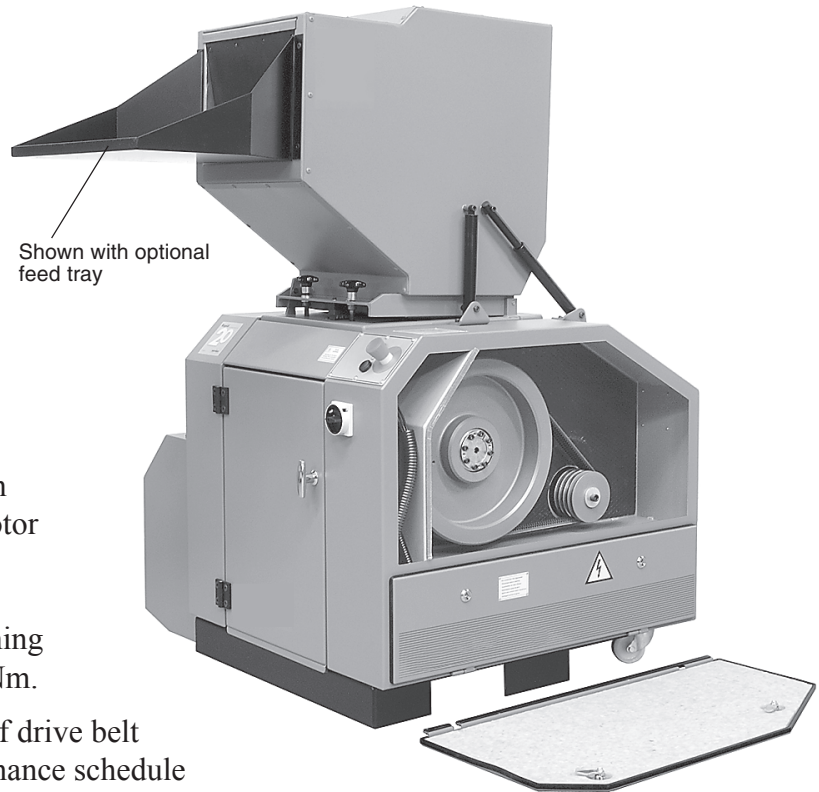

- When the drive belt tension is correct set, fasten the motor with the screws (M10, key width 16 mm) to the motor locking rules with a tightening torque of 40 Nm.



NOTE! Note the adjustment of drive belt tension in the machine maintenance schedule

Make a re-check of the drive belt tension

- If the drive belt tension is adjusted, the belt need to be re-checked after 20 - 30 hours at normal load.

Check the tightening torque of the screw which retains the granulator motor to the motor locking rules.



Screw M10 (key width 16 mm) tightening torque 40 Nm.

NOTE! Sign the executed inspection in the machine maintenance schedule.

7.4 Lubrication

Cutter house

The bearings in the cutter housing are permanently greased, and do not need greasing in normal circumstances.

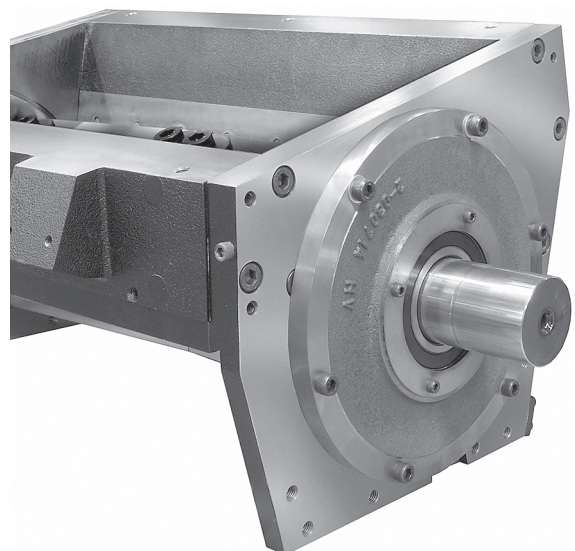

7.5 Cutter belt pulley/Motor pulley

For to remove/install the cutter belt pulley or the motor pulley must the upper door on right hand side of the granulator be opened and lifted away.

The transmission with cutter belt pulley and motor pulley is now accessible.

Then undo and remove the rear protective cover above the motor from rear side of the granulator.

Undo and remove the granule bin and screen box, then are the front retaining screws to the motor accessible.

Then reduce the tension of the drive belts so that the drive belts can removed.

Read and reduce the tension of the drive belts as per “Adjustment of drive belts” in previous chapter.

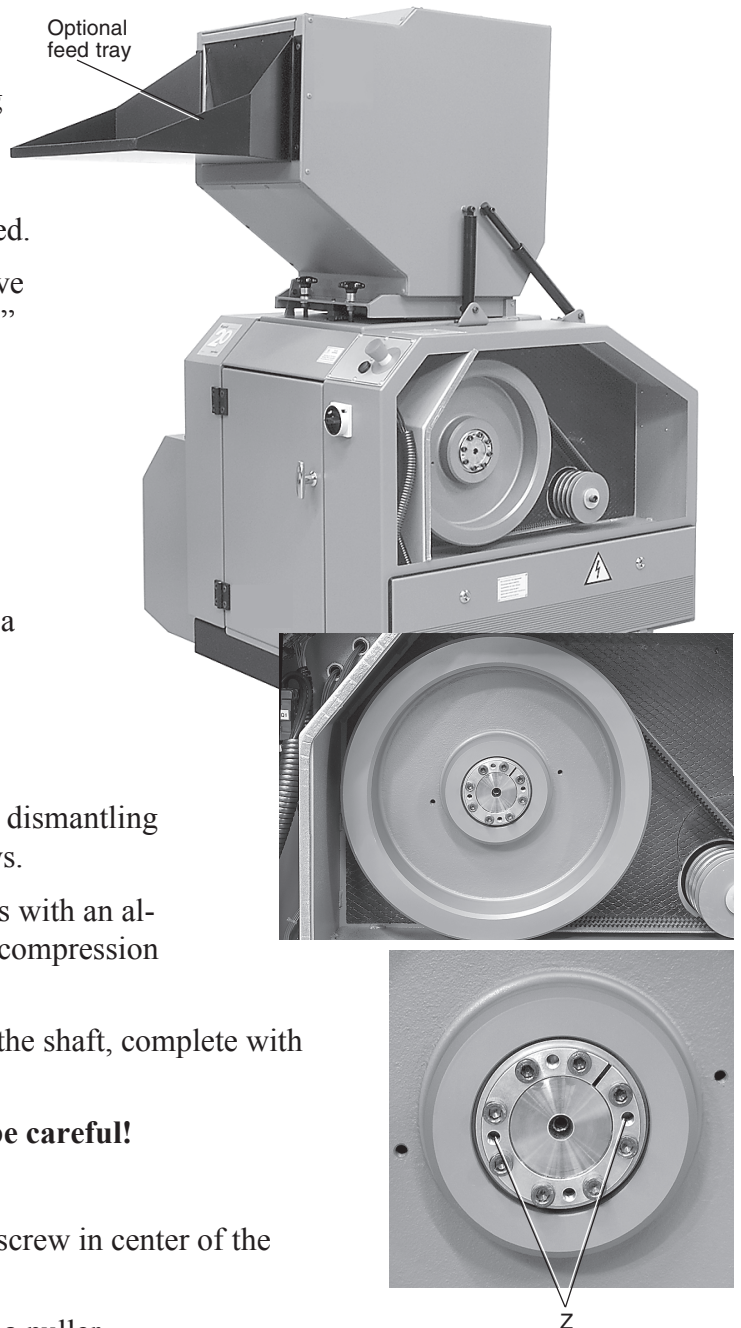

Removing

First reduce the tension of the V-belts, then remove the V-belts.

Cutter belt pulley

The cutter belt pulley is installed with a compression bush.

- Undo all 8 screws a few turns.
- Remove two screws.
- Put a drop of oil in each of the two dismantling holes “Z” and then insert the screws.
- Tighten the two dismantling screws with an alternated increased torque until the compression bush comes loose from the shaft.
- Lift off the cutter belt pulley from the shaft, complete with the compression bush.



NOTE! The cutter pulley is heavy, be careful!

Motor pulley

- Undo and remove the socket head screw in center of the motor pulley.
- Remove the motor pulley by using a puller.

Installation

Motor pulley

- Install the motor pulley on the motor shaft, ensure that the key fits.
- Fasten the motor pulley using the socket head screw in center of the shaft 120 Nm.

Cutter belt pulley

The cutter belt pulley is installed with a compression bush.

- Clean and degrease the cutter pulley.
- Oil lightly the cutter shaft.
- Oil the screws and install then the compression bush lightly on the belt pulley.
- Lift the belt pulley on to the cutter shaft.
- Adjust and ensure that the cutter belt pulley is in line with the motor pulley.
- Tighten the screws in the compression bush.

Tighten the screws cross wise equal, with increased torque to 20 Nm.

- Tap lightly on the compression bush between the shaft and the screws.
Use a piece of wood or plastic.

- Tighten the belt pulley with the compression bush.

Tighten the screws cross wise equal to torque 40 Nm.

- Read and set the tension of the drive belts as per “Adjustment of drive belts” in previous chapter.
- Re-install the screen box, the granule bin, the upper door on right hand side of the granulator and the rear protective cover above the motor.

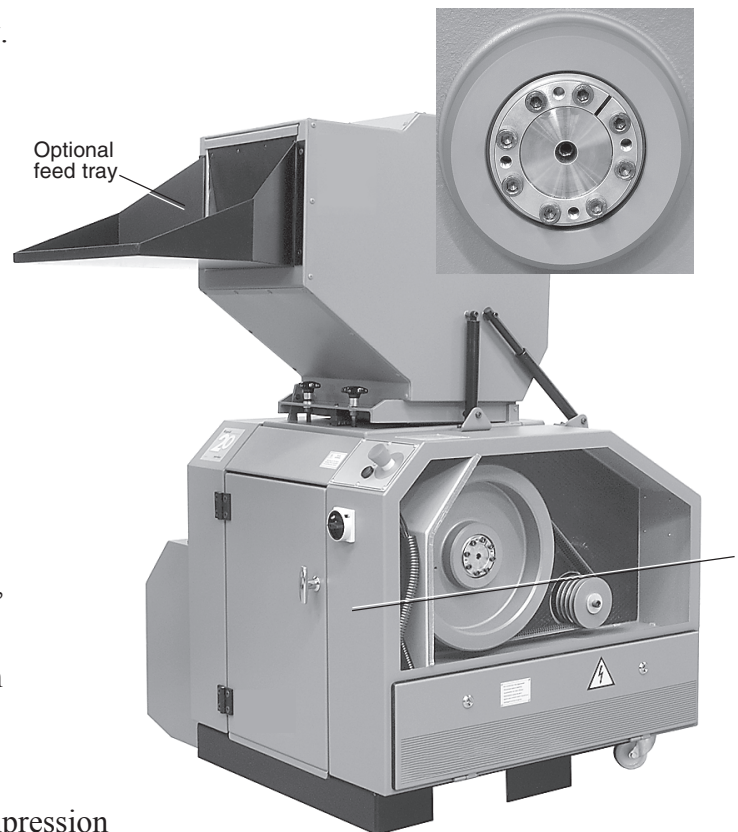

8. Spare parts list

Overview

The granulator is divided into the following modules:		Page
8.1	Cutter house	8:2
8.2	Cutter	8:4
8.3	Cutter, open cutter	8:5
8.4	Knives, 3-step cutter	8:6
8.5	Knives, open cutter	8:7
8.6	Transmission	8:8
8.7	Screen	8:9
8.8	Screen box	8:10
8.9	Outfeed, granule bin	8:11
8.10	Outfeed, blower F-7/F-15	8:12
8.11	Hopper	8:13
8.12	Details to hopper	8:14
8.13	Hopper, rear -KUP (sheet feed option)	8:15
8.14	Hopper device	8:16
8.15	Safety	8:17
8.16	Enclosure	8:18
8.17	Enclosure, transmission	8:19
8.18	Body	8:20
8.19	Tools, accessories and fixtures	8:21

Ordering spare parts

Only use spare parts from Conair when replacing machine parts.

Orders should go to the representative in the country where the machine was purchased.

When ordering, the following should be specified:

- Machine designation, as specified on the machine plate.
- Serial number, as specified on the machine plate.
- Part number, as specified in the spare parts list.
- Quantity, as specified in this spare parts list.

8.1 Cutter house

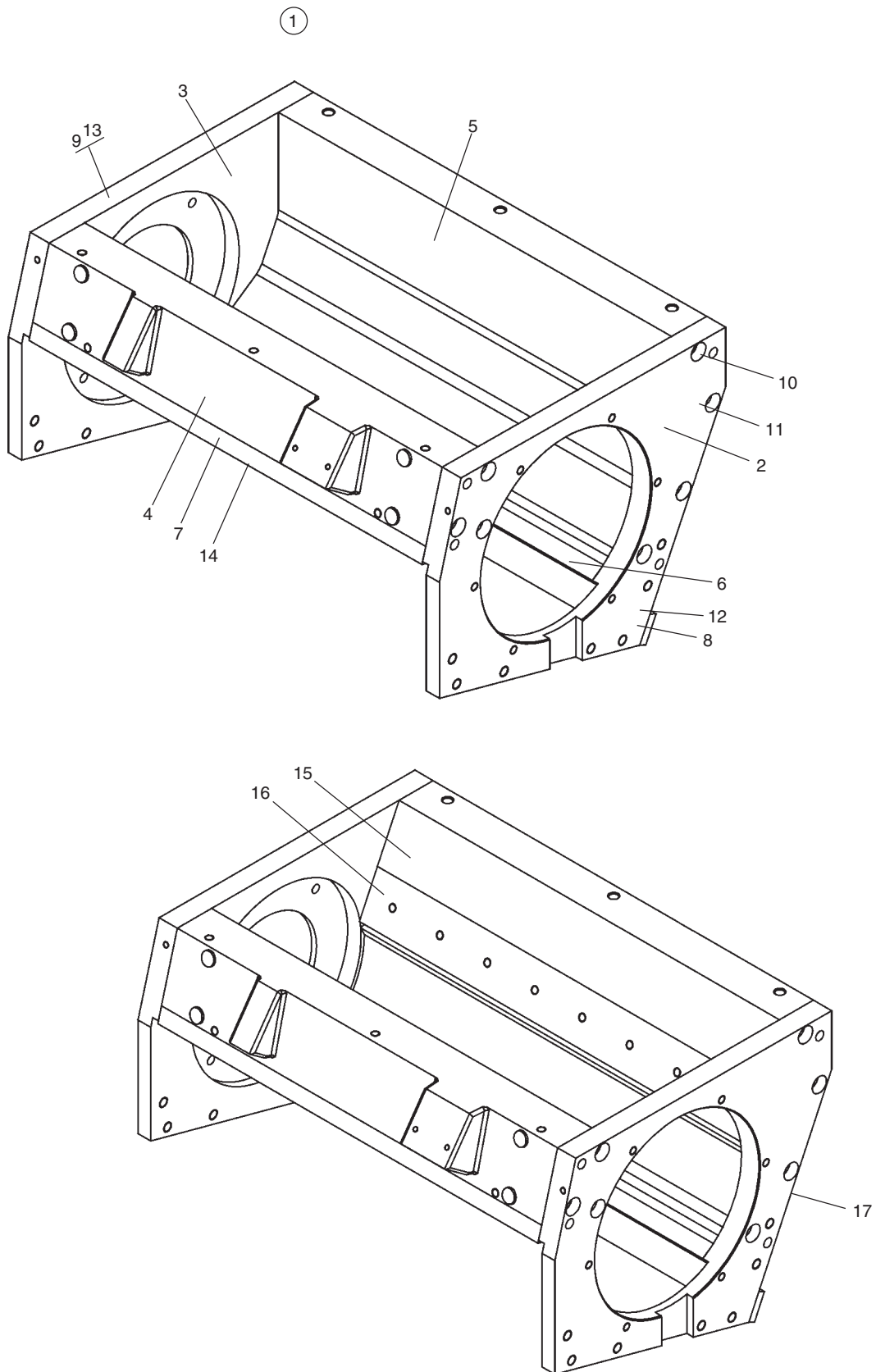

8.2 Cutter

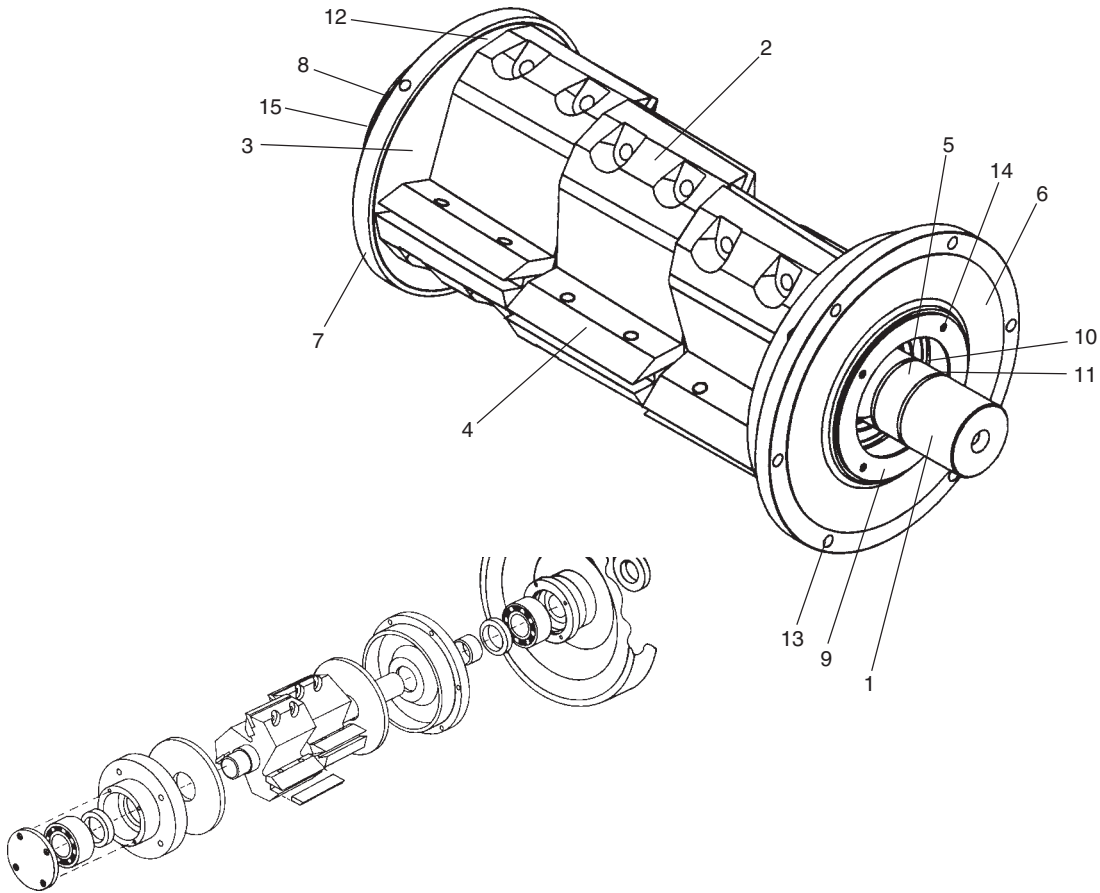

Pos	Qty.															Art. no.	Description
	1	2	3	4	5	6	7	8	9	10	11	12	13	14	15		
																3-29702	Cutter 810 3-blade
																3-30260	Cutter 810 3-blade hardened
																3-29703	Cutter 814 3-blade
																3-30261	Cutter 814 3-blade hardened
																3-29704	Cutter 819 3-blade
																3-30262	Cutter 819 3-blade hardened
																3-44926	Cutter 824 3-blade
																3-48236	Cutter 824 3-blade hardened
1	1	1	-	-	-	-	-	-	-	-	-	-	-	-	-	3-29530	Cutter shaft 3-blade
	-	-	1	1	-	-	-	-	-	-	-	-	-	-	-	3-29531	- " -
	-	-	-	-	1	1	-	-	-	-	-	-	-	-	-	3-29532	- " -
	-	-	-	-	-	-	-	-	1	1	-	-	-	-	-	3-44919	- " -
2	2	2	3	3	4	4	6	6								3-29501	Segment
3	2	-	2	-	2	-	2	-								3-29502	Ring
	-	2	-	2	-	2	-	2								4-30249	- " -
4	6	6	9	9	12	12	15	15								3-46410	Support rule
5	1	1	1	1	1	1	1	1								4-29529	Sleeve
6	1	-	1	-	1	-	1	-								2-29505	Plummer block, right
	-	1	-	1	-	1	-	1								2-30714	- " -
7	1	-	1	-	1	-	1	-								2-29506	Plummer block, left
	-	1	-	1	-	1	-	1								2-30715	- " -
8	1	1	1	1	1	1	1	1								3-29527	Cover, Left
9	1	1	1	1	1	1	1	1								4-29528	Cover, right
10	2	2	2	2	2	2	2	2								960182	Bearing
11	2	2	2	2	2	2	2	2								960183	Sealing ring
12	6	6	6	6	6	6	6	6								940579	Socket head screw M8
13	6	6	6	6	6	6	6	6								940007	Socket head screw M8
14	8	8	8	8	8	8	8	8								940071	Socket head screw M5
15	4	4	4	4	4	4	4	4								940032	Socket head screw M8

8.3 Cutter, Open cutter

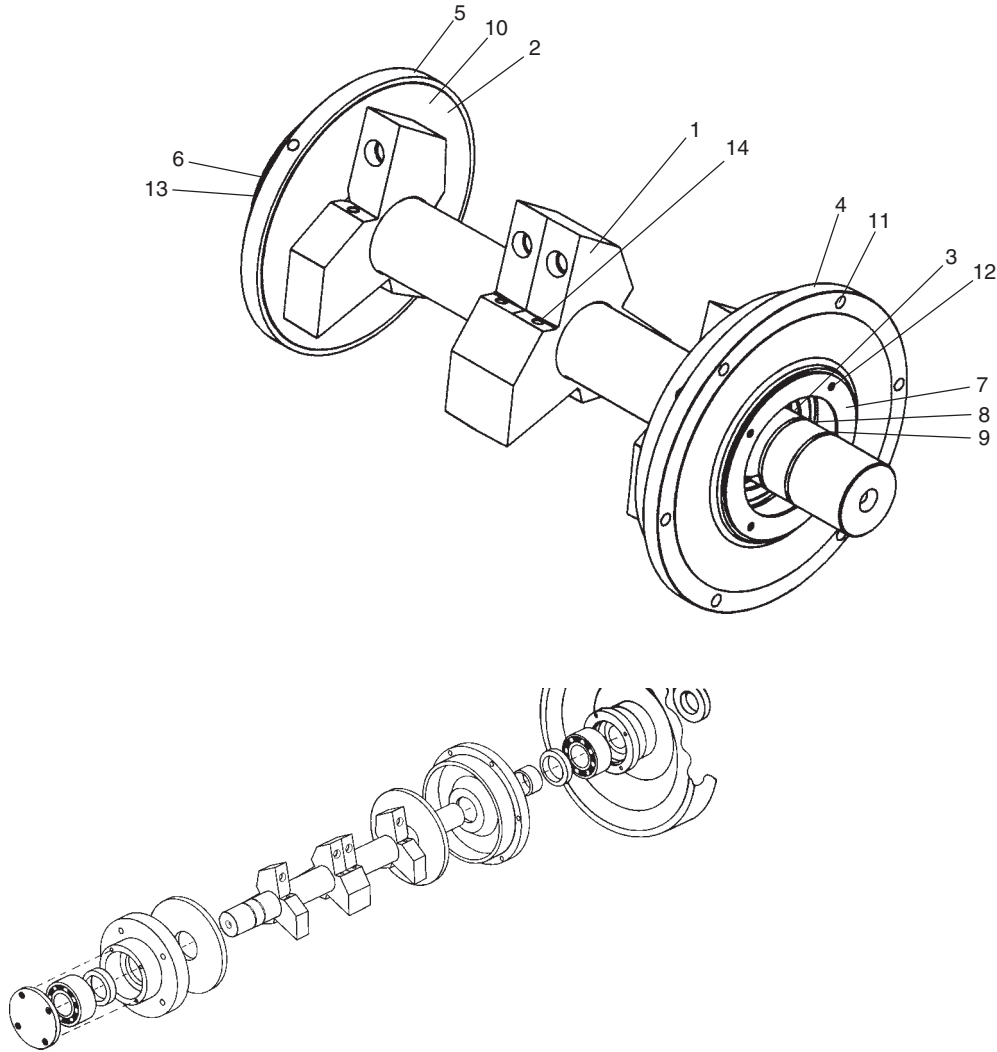

Pos	Qty.									Art. no.	Description
										3-30113	Cutter 810 3-blade open
										3-30263	Cutter 810 3-blade open hardened
										3-29753	Cutter 814 3-blade open
										3-30264	Cutter 814 3-blade open hardened
										3-30114	Cutter 819 3-blade open
										3-30265	Cutter 819 3-blade open hardened
										3-44926	Cutter 824 3-blade open
										3-48236	Cutter 824 3-blade open hardened
1	1	1	-	-	-	-	-	-	┌	1-30104	Cutter 3-blade
	-	-	1	1	-	-	-	-	-	1-29743	- " -
	-	-	-	-	1	1	-	-	-	1-30106	- " -
	-	-	-	-	-	-	-	1	1	3-44920	- " -
2	2	-	2	-	2	-	2	-	2	3-29502	Ring
	-	2	-	2	-	2	-	2	2	4-30249	Ring
3	1	1	1	1	1	1	1	1	1	4-29529	Sleeve
4	1	-	1	-	1	-	1	-	1	2-29505	Plummer block, right
	-	1	-	1	-	1	-	1	1	2-30714	- " -
5	1	-	1	-	1	-	1	-	1	2-29506	Plummer block, left
	-	1	-	1	-	1	-	1	1	2-30715	- " -
6	1	1	1	1	1	1	1	1	1	3-29527	Cover, left
7	1	1	1	1	1	1	1	1	1	4-29528	Cover, right
8	2	2	2	2	2	2	2	2	2	960182	Bearing
9	2	2	2	2	2	2	2	2	2	960183	Sealing ring
10	6	6	6	6	6	6	6	6	6	940579	Socket head screw, low M8
11	6	6	6	6	6	6	6	6	6	940007	Socket head screw M8
12	8	8	8	8	8	8	8	8	8	940071	Socket head screw M5
13	4	4	4	4	4	4	4	4	4	940032	Socket head screw M8
14	12	12	12	12	12	12	12	12	12	4-43263	Set screw M8

8.4 Knives, 3-step cutter

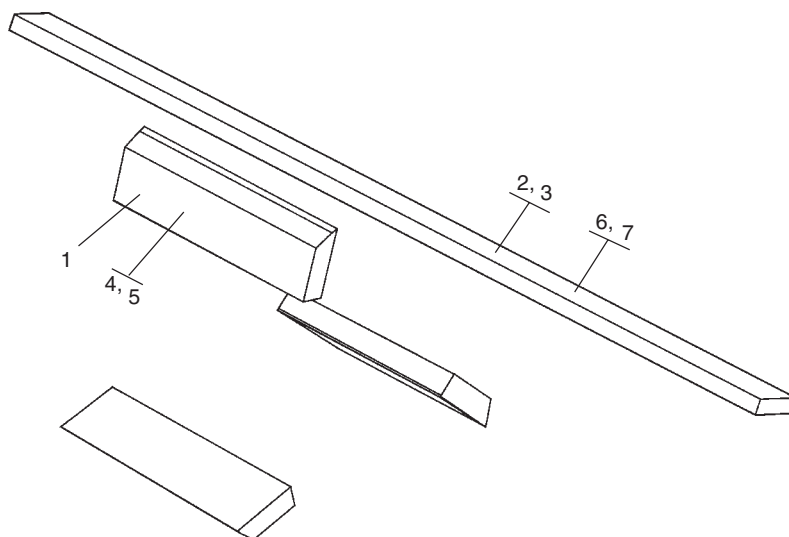

Pos	Qty.				Art. no.	Description	Note
	┌	┌	┌	┌			
1	6	9	12	15	3-29503	Knife, rotating	Standard
	6	9	12	15	3-32366	— " —	Vanadis 4
	6	9	12	15	3-33567	— " —	Carbide
	6	9	12	15	3-33567	— " —	Standard
2	2	-	-	-	2-29515	Knife, fixed	Standard
	-	2	-	-	2-29516	— " —	— " —
	-	-	2	-	2-29517	— " —	— " —
	-	-	-	4	3-44922	— " —	— " —
	2	-	-	-	3-40941	Knife, fixed	Vanadis 4
	-	2	-	-	3-32367	— " —	— " —
	-	-	2	-	3-34621	— " —	— " —
	-	-	-	-	— " —	— " —	— " —
	2	-	-	-	3-39113	Knife, fixed	Carbide
	-	2	-	-	3-33568	— " —	— " —
	-	-	2	-	3-35470	— " —	— " —
	-	-	-	-	— " —	— " —	— " —
3	1	-	-	-	2-29515	Knife, third fixed	Standard
	-	1	-	-	2-29516	— " —	— " —
	-	-	1	-	2-29517	— " —	— " —
	-	-	-	2	3-44922	— " —	— " —
	1	-	-	-	3-40941	Knife, third fixed	Vanadis 4
	-	1	-	-	3-32367	— " —	— " —
	-	-	1	-	3-34621	— " —	— " —
	-	-	-	-	— " —	— " —	— " —
	1	-	-	-	3-39113	Knife, third fixed	Carbide
	-	1	-	-	3-33568	— " —	— " —
-	-	1	-	3-35470	— " —	— " —	
-	-	-	-	— " —	— " —	— " —	
4	12	18	24	30	940004	Socket head screw M10	to rotating knife
5	12	18	24	30	940031	Washer	— " —
6	8	12	16	-	940778	Socket head screw M8	to fixed knife
7	4	6	8	-	940779	Socket head screw	to 3:rd fixed knife

8.5 Knives, open cutter

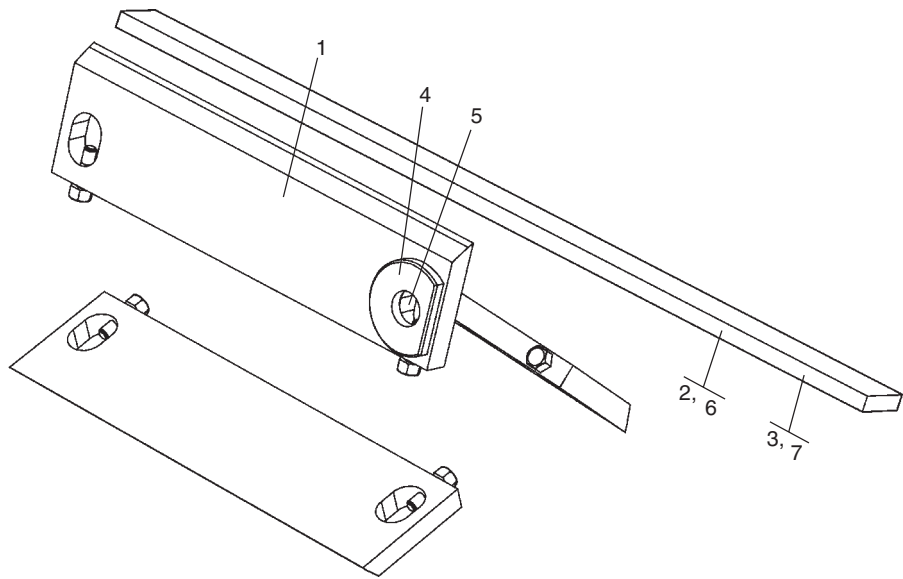

Pos	Qty.				Art. no.	Description	Note
	┌	┌	┌	┌			
1	6	-	-	-	3-30108	Granulator 810 with open cutter Knife, rotating	Standard
	-	6	-	-	3-29750	—"	—"
	-	-	6	-	3-30109	—"	—"
	-	-	-	6	3-44923	—"	—"
	6	-	-	-	3-41323	Knife, rotating	Vanadis 4
	-	-	-	-	-	—"	—"
	-	-	-	-	-	—"	—"
	-	-	-	-	-	—"	—"
	6	-	-	-	-	Knife, rotating	Carbide
	-	6	-	-	3-33517	—"	—"
	-	-	6	-	3-35471	—"	—"
	-	-	-	-	-	—"	—"
	6	-	-	-	3-30136	Knife, rotating	Hard metal
	-	6	-	-	3-35920	—"	—"
-	-	6	-	3-40252	—"	—"	
2	-	-	-	-	-	—"	—"
	2	-	-	-	2-29515	Knife, fixed	Standard
	-	2	-	-	2-29516	—"	—"
	-	-	2	-	2-29517	—"	—"
	-	-	-	4	3-44922	—"	—"
	2	-	-	-	3-40941	Knife, fixed	Vanadis 4
	-	2	-	-	3-32367	—"	—"
	-	-	2	-	3-34621	—"	—"
	-	-	-	-	-	—"	—"
	2	-	-	-	3-39113	Knife, fixed	Carbide
	-	2	-	-	3-33568	—"	—"
	-	-	2	-	3-35470	—"	—"
	-	-	-	-	-	—"	—"
	-	-	-	-	-	—"	—"
3	1	-	-	-	2-29515	Knife, third fixed	Standard
	-	1	-	-	2-29516	—"	—"
	-	-	1	-	2-29517	—"	—"
	-	-	-	2	3-44922	—"	—"
	1	-	-	-	3-40941	Knife, third fixed	Vanadis 4
	-	1	-	-	3-32367	—"	—"
	-	-	1	-	3-34621	—"	—"
	-	-	-	-	-	—"	—"
	1	-	-	-	3-39113	Knife, third fixed	Carbide
	-	1	-	-	3-33568	—"	—"
-	-	1	-	3-35470	—"	—"	
-	-	-	-	-	—"	—"	
4	12	12	12	4-29751	Washer	to rotating knife	
5	12	12	12	940776	Socket head screw, low M16	—"	
6	8	12	16	940778	Socket head screw M8	to fixed knife	
7	4	6	8	940779	Socket head screw M8	to 3:rd fixed knife	

8.6 Transmission

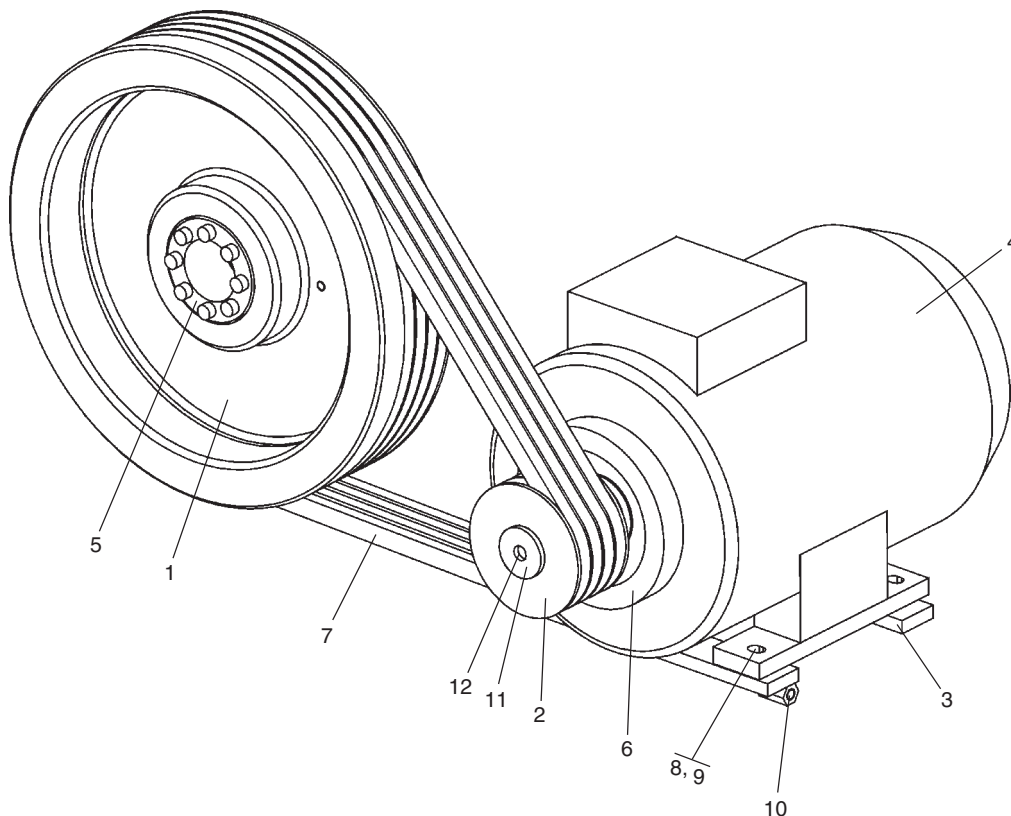

Pos	Qty.						Art. no.	Description
	┌	┐	┌	┐	┌	┐		
							Transmission 5 Hp {4.0 kW} 1100 rpm	
							Transmission 5 Hp {4.0 kW} 1800 rpm	
							Transmission 7.5 Hp {5.5 kW} 1100 rpm	
							Transmission 7.5 Hp {5.5 kW} 1800 rpm	
							Transmission 10 Hp {7.5 kW} 1800 rpm	
							Transmission 15 Hp {11.0 kW} 1800 rpm	
1	1	1	1	1	1	1	9-30233 Pulley, cutter	
2	1	1	1	1	1	1	9-30234 Pulley, motor	
3	2	2	2	2	2	2	3-29552 Belt tensioner	
4	1	1	1	1	1	1	*) Motor (See table below)	
5	1	1	1	1	1	1	930222 Coupling	
6	1	1	1	1	1	1	970214 Ring	
7	3	3	3	3	3	3	930221 V-belt XPA	
8	4	4	4	4	4	4	940092 Hex head screw M10	
9	6	6	6	6	6	6	940031 Washer BRB	
10	2	2	2	2	2	2	940744 Hex head screw M10	
11	1	1	1	1	1	1	940648 Washer, thick	
12	1	1	1	1	1	1	940051 Socket head screw M12	

CLS	Motor	Speed	Voltage/Frequency *)	
		rpm		
	5 Hp {4.0 kW}	1100	U101-13-0232	208-460V
	7.5 Hp {5.5 kW}	1100	U101-13-0224	230-460V only

CHS	Motor	Speed	Voltage/Frequency *)	
		rpm		
	5 Hp {4.0 kW}	1800	U101-13-0231	208-460V
	7.5 Hp {5.5 kW}	1800	U101-13-0223	208-460V
	10 Hp {7.5 kW}	1800	U101-13-0225	208-460V
	15 Hp {11.0 kW}	1800	U101-13-0226	230-460V only

8.7 Screen

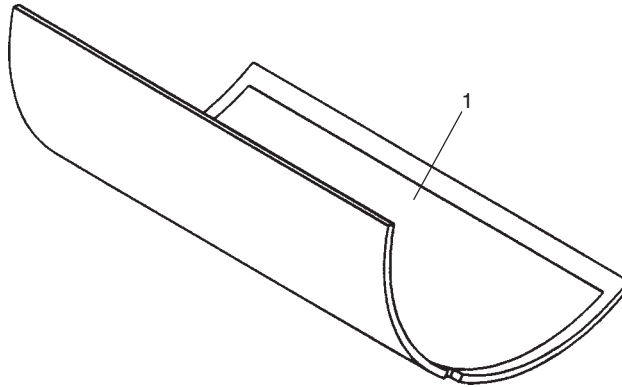

Pos	Qty.		Art. no.	Description	Note		
1	1	-	-	3-29574	Screen		
	1	-	-	4-30251	- " -	hardened	
	1	-	-	3-31688	Screen, stitch reduced		
	1	-	-	4-31691	- " -	hardened	
	-	1	-	-	3-29575	Screen	
	-	1	-	-	4-30252	- " -	hardened
	-	1	-	-	3-31689	Screen, stitch reduced	
	-	1	-	-	4-31692	- " -	hardened
	-	-	1	-	3-29576	Screen	
	-	-	1	-	4-30253	- " -	hardened
	-	-	1	-	3-31690	Screen, stitch reduced	
	-	-	1	-	4-31693	- " -	hardened
	-	-	-	1	3-46065	Screen	
	-	-	-	1	4-48238	- " -	hardened
	-	-	-	1	3-48239	Screen, stitch reduced	
	-	-	-	1	4-48240	- " -	hardened

NOTE! Specify art. no. and required hole diameter 4, 5, 6, 8 and 10 mm.

8.8 Screen box

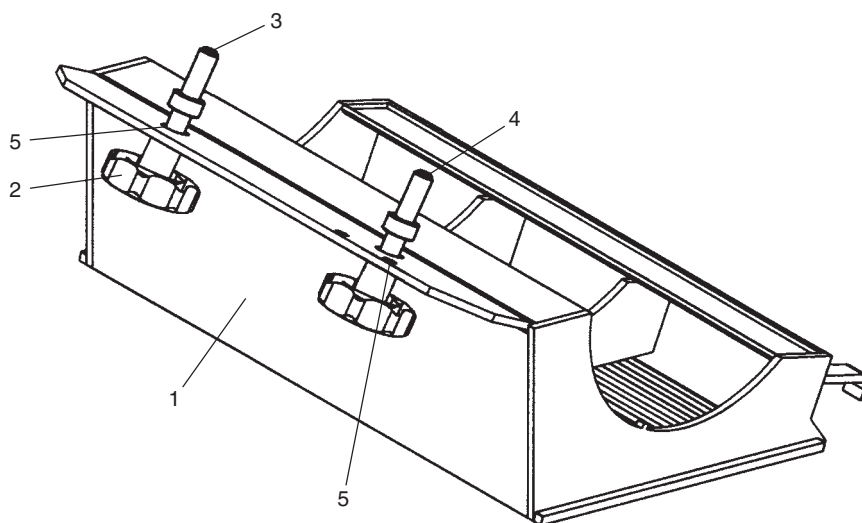

Pos	Qty.	Art. no.	Description	Note
1	1	1-29560	Screen box	
	1	1-29656	–"–	stitch reduced
	1	1-34611	–"–	for screen Ø 8 mm - larger
	1	1-29561	Screen box	
	1	1-29657	–"–	stitch reduced
	1	1-34612	–"–	for screen Ø 8 mm - larger
	1	1-29562	Screen box	
	1	1-29658	–"–	stitch reduced
	1	1-34613	–"–	for screen Ø 8 mm - larger
	1	1-44970	Screen box	
	1	1-48245	–"–	stitch reduced
	1	1-46559	–"–	for screen Ø 8 mm - larger
	2	2	950532	Star knob
3	1	4-30327	Locking bolt M12	
4	1	4-30328	Locking bolt M12	
5	4	940155	Washer	

8.9 Outfeed, granule bin

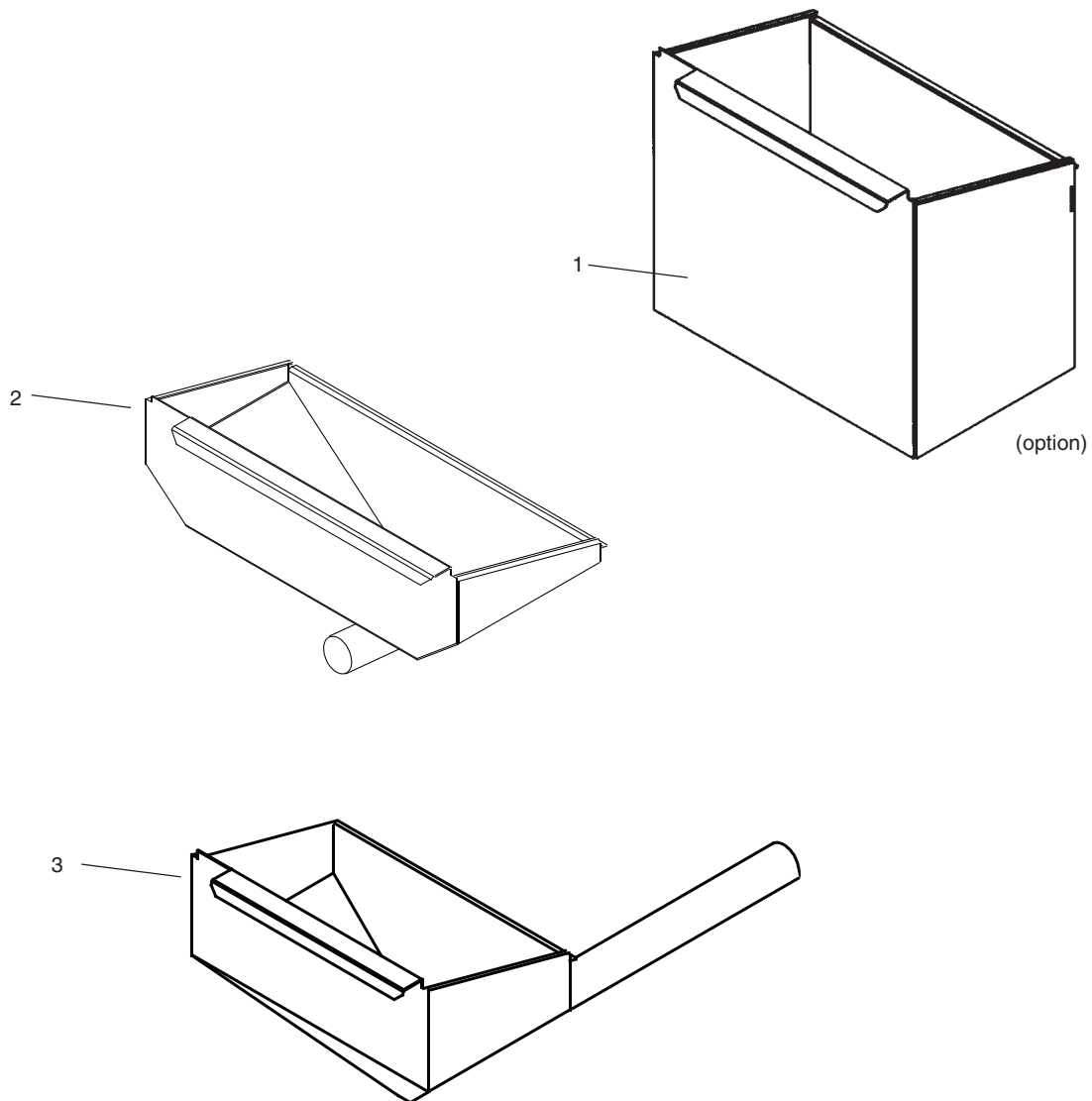

Pos	Qty.									Art. no.	Description	Note
											Granulator 810	
											Granulator 810-K	
											Granulator 814	
											Granulator 814-K	
											Granulator 819	
											Granulator 819-K	
											Granulator 824	
											Granulator 824-K	
1	1	1	-	-	-	-	-	-	-	1-29577	Granule bin, manual	15 L
	1	1	-	-	-	-	-	-	-	3-35747	-"	with window 15 L
	-	-	1	1	-	-	-	-	-	1-29578	-"	22 L
	-	-	-	-	1	-	-	-	-	1-29579	-"	29 L
	-	-	-	-	-	-	1	1	-	1-47106	-"	36 L
2	1	1	-	-	-	-	-	-	-	2-56085	Front discharge	
	-	-	1	1	-	-	-	-	-	2-43059	-"	
	-	-	-	-	1	1	-	-	-	2-57251	-"	
	-	-	-	-	-	-	1	1	-	2-56091	-"	
3	1	1	-	-	-	-	-	-	-	1-44715	Rear discharge	
	-	-	1	1	-	-	-	-	-	1-44508	-"	
	-	-	-	-	1	1	-	-	-	1-44716	-"	
	-	-	-	-	-	-	1	1	-	1-44975	-"	

8.10 Outfeeds, blower F-7/F-15

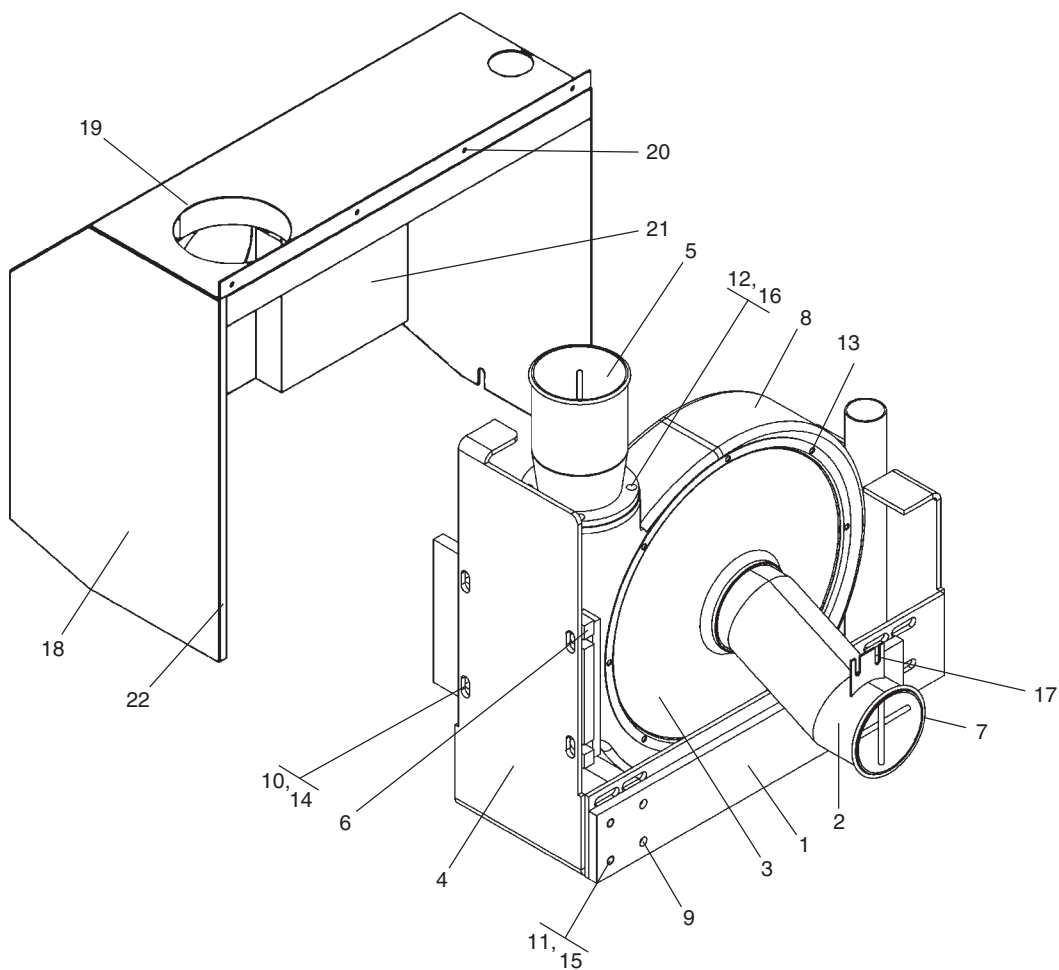

Pos	Qty.	Art. no.	Description	Note
			Blower F-7	
			Blower F-15	
1	1	3-29759	Distance	
2	1	2-36045	Pipe stub D-100	
3	1	3-30267	Pipe stub inlet	
4	1	1-22825	Holder blower	
5	1	3-13138	Pipe stub outlet	F-7
	-	3-10332	Pipe stub outlet	F-15
6	1	4-24655	Holder blower	
7	1	920415	Quick coupling ring	
8	1	-*)	Blower F-7 (See table below)	0,55 kW
	-	*)	Blower F-15 (See table below)	0,90 kW
9	4	940347	Socket head screw M10	
10	4	940004	Socket head screw M10	
11	4	940201	Socket head screw M10	
12	4	940426	Hex head screw M8	
13	8	940039	Socket head screw M6	
14	6	940015	Nut M10	
15	8	940031	Washer BRB	
16	4	940592	Washer BRB FZB	
17	2	940213	Socket head screw M6	
18	1	1-22824	Cover blower	
19	1	970152	Sealing ring	
20	8	940750	Screw	
21	1	4-46522	Noise absorber	
22	1	4-46523	Noise absorber	

Blower	Voltage/Frequency				
	200-220V/50Hz	200-220V/60Hz	380V/60Hz	220-240V/50Hz 380-420V/50Hz	440-480V/60Hz
F-7	920877	920878	992187	920206	992828
F-15	920879	920880	992136	920421	992829

8.11 Hopper - Insulated

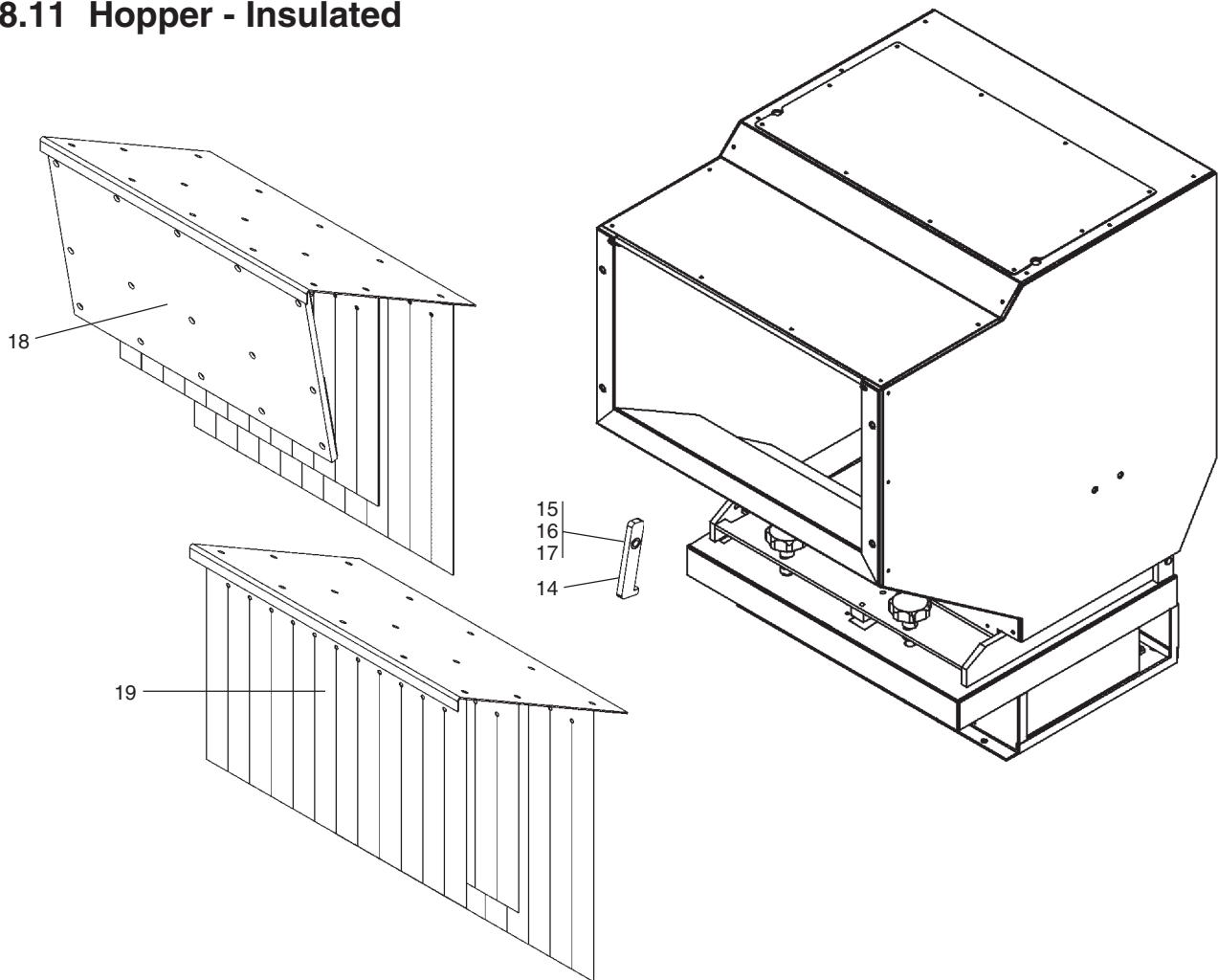

Pos	Qty.	Art. no.	Description	Note
			Granulator 810	
			Granulator 814	
			Granulator 819	
			Granulator 824	
1	1	1-30614	Hopper front	240x220
	-	1-29761	-"	360x220
	-	1-30618	-"	480x220
	-	1-46421	-"	600x220
2	1	1-29595	Frame	
	-	1-29596	-"	
	-	1-29597	-"	
	-	1-46075	-"	
3	1	4-30495	Shaft	
	-	4-29734	-"	
	-	4-30628	-"	
	-	4-46076	-"	
4	1	4-29646	Bracket, key switch	
5	1	4-30327	Locking bolt M12	
6	1	4-30328	Locking bolt M12	
7	2	950532	Star knob	
8	6	940097	Socket head screw M8	
9	2	940071	Socket head screw M5	
10	4	940155	Washer BRB FZB	
11	1	940696	Grub screw	
12	1	992455	List	
13	1	970218	List	
14	1	4-30093	Stop double	
15	1	4-22129	Distance	
16	1	940162	Washer BRB	
17	1	940662	Socket head screw M8	
18	1	3-30337	Flap	front rigid
	-	3-30338	-"	-"
	-	3-30339	-"	-"
	-	3-47392	-"	-"
19	1	3-30343	Flap, textile	
	-	3-30344	-"	
	-	3-29533	-"	
	-	3-46077	-"	

8.12 Details to hopper

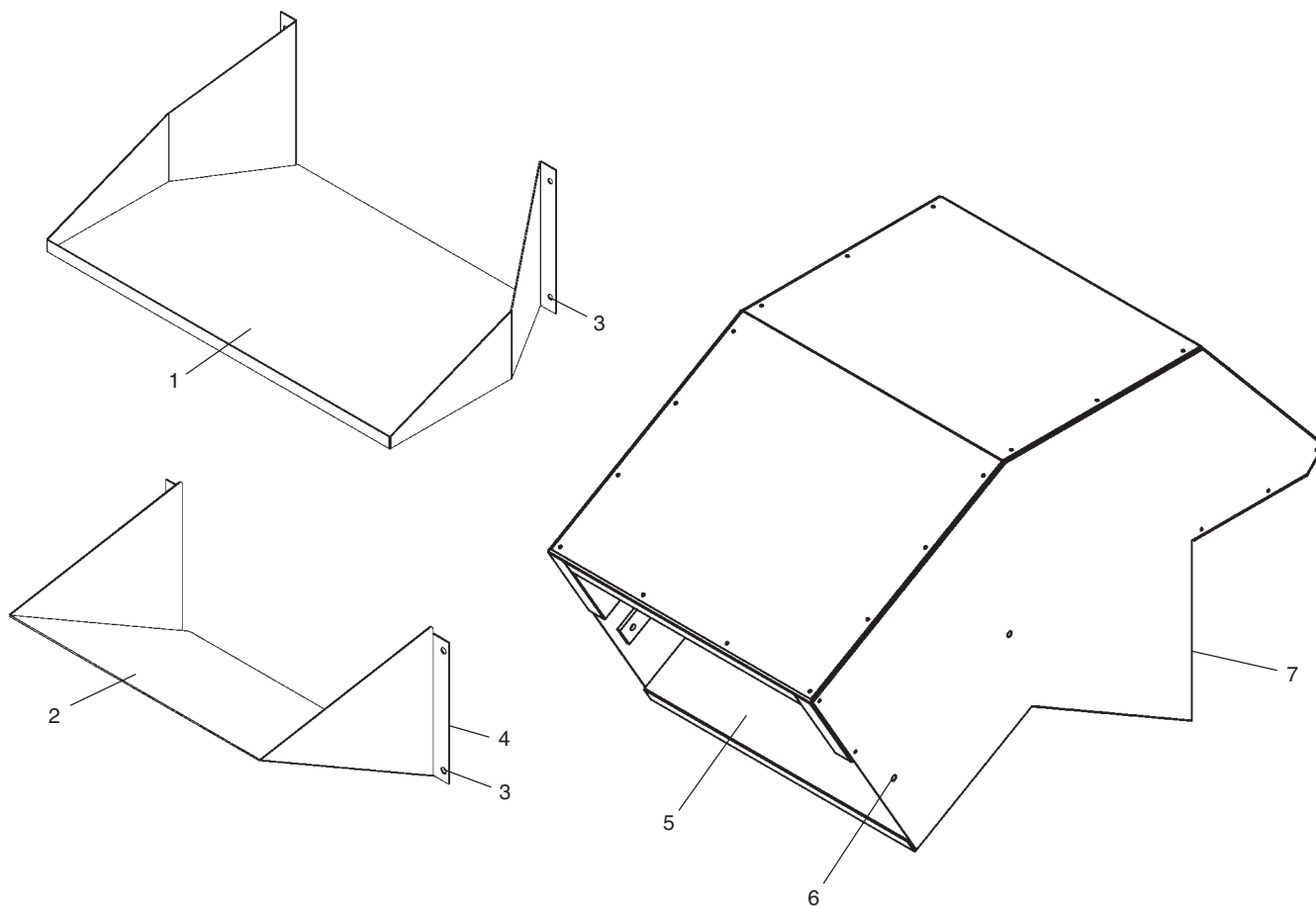

Pos	Qty.	Art. no.	Description	Note
1	1	2-30494	Granulator 810	
	-	2-29787	Granulator 814	
	-	2-30641	Granulator 819	
	-	2-47384	Granulator 824	
	-	-	Feed table	
2	1	2-29789	Hopper funnel	
	-	2-29788	-"	
	-	2-29790	-"	
	-	2-46423	-"	
	-	-	-"	
3	4	940587	Socket head screw M8	
	1	970141	List	self-adhering
	-	992455	-"	-"
	-	-	-"	-"
5	1	2-30673	Sound trap, hopper -KUB	to band conveyor
	-	2-30654	-"	
	-	2-30666	-"	
	-	-	-"	
6	4	940097	Socket head screw M8	
	-	940032	-"	M8
	-	940070	-"	M8
	-	-	-"	-"
7	1	970218	List	self-adhering

8.13 Hopper rear - Insulated sheet feed

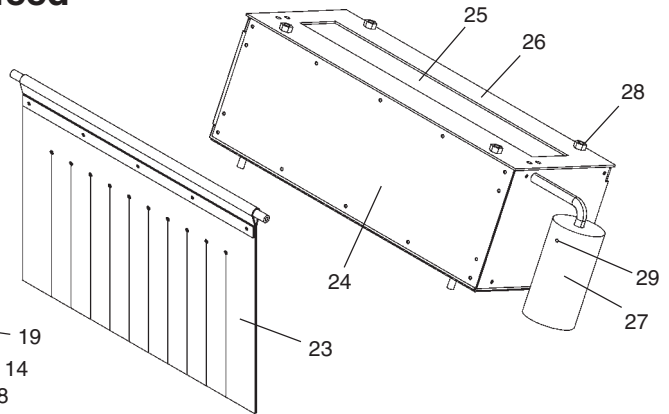
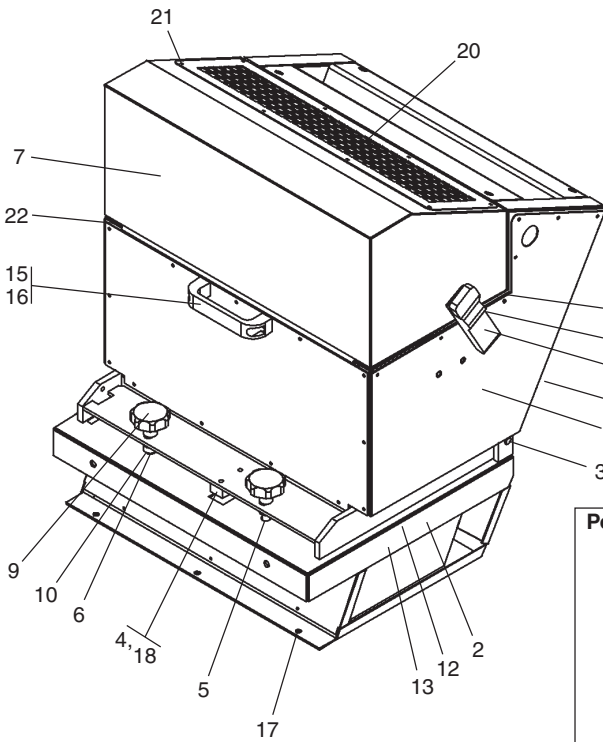

Pos	Qty.	Art. no.	Description	Note
			Granulator 810	
			Granulator 814	
			Granulator 819	
			Granulator 824	
1	1	2-34045	Hopper rear -Insulated sheet feed	
	-	2-34222	—"	
	-	2-34039	—"	
	-	-	—"	
2	1	1-29598	Frame	3:rd fixed knife
	-	1-29599	—"	
	-	1-29600	—"	
	-	-	—"	
3	1	4-30495	Shaft	
	-	4-29734	—"	
	-	4-30628	—"	
	-	-	—"	
4	1	4-29646	Bracket key switch	
5	1	4-30327	Locking bolt M12	
6	1	4-30328	Locking bolt M12	
7	1	1-34227	Sound trap	
	-	1-34228	—"	
	-	1-34037	—"	
	-	-	—"	
8	2	950572	Eccentric lock	
9	2	950532	Star knob	
10	4	940155	Washer BRB	
11	1	940696	Grub screw S6SS	
12	1	992455	List, self-adhering	cellular rubber
13	1	970218	List, self-adhering	EPDM
14	8	940432	Pop-rivet, steel	
15	1	991984	Stirrup handle	
16	2	940070	Socket head screw M8	
17	6	940097	Socket head screw M8	
18	2	940071	Socket head screw M5	
19	2	940051	Socket head screw M12	
20	1	3-37712	Covering plate, sound trap	
	-	3-37713	—"	
	-	3-37714	—"	
	-	-	—"	
21	6	940750	Self tapping screw	
22	1	970148	List, self-adhering	cellular rubber
23	1	3-30504	Flap	
	-	3-29680	—"	
	-	3-30116	—"	
	-	-	—"	
24	1	2-29694	Flap package, rear	
	-	2-29669	—"	
	-	2-30132	—"	
	-	-	—"	
25	1	2-29699	Flap	
	-	2-29674	—"	
	-	2-30506	—"	
	-	-	—"	
26	1	3-30501	Cover	
	-	3-29678	—"	
	-	3-30102	—"	
	-	-	—"	
27	1	4-27106	Counter weight	
28	4	4-30103	Hex head screw	
29	1	940102	Grub screw	

8.14 Hopper device

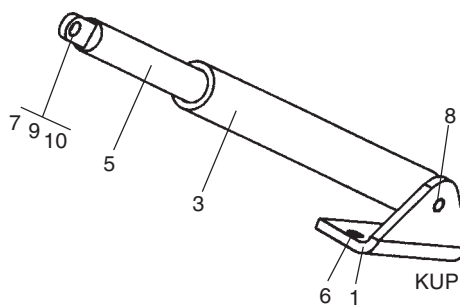
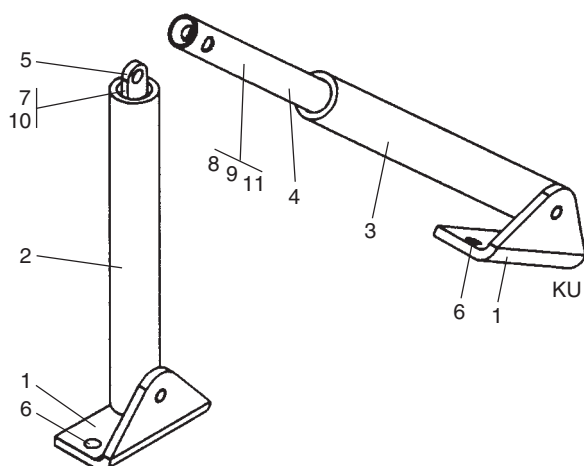

Pos	Qty.								Art. no.	Description
	┌	┐	┌	┐	┌	┐	┌	┐		
1	2	-	2	-	2	-	2	-	3-29777	Granulator 810 hopper device -Insulated
	-	1	-	1	-	1	-	1	3-30497	Granulator 810 hopper device -Insulated sheet feed (rear)
2	1	-	1	-	1	-	1	-	3-30325	Granulator 814 hopper device -Insulated
	-	1	-	1	-	1	-	1	3-29779	Granulator 814 hopper device -Insulated sheet feed (rear)
3	1	-	1	-	1	-	1	-	3-30498	Granulator 819 hopper device -Insulated
	-	1	-	1	-	1	-	1	3-30326	Granulator 819 hopper device -Insulated sheet feed (rear)
4	1	-	1	-	1	-	1	-	920768	Granulator 824 hopper device -Insulated
	-	1	-	1	-	1	-	1	920769	Granulator 824 hopper device -Insulated sheet feed (rear)
5	1	-	1	-	1	-	1	-	920768	Gas spring
	-	1	-	1	-	1	-	1	920769	" "
	-	-	-	1	-	-	-	-	920763	" "
	-	-	-	-	-	1	-	-	920655	" "
	-	-	-	-	-	-	-	1	" "	" "
6	4	2	4	2	4	2	4	2	940032	Bracket
7	4	1	4	1	4	1	4	1	940200	Socket head screw M8
8	-	1	-	1	-	1	-	1	940054	Socket head screw M8
9	2	1	2	1	2	1	2	1	940585	Washer
10	7	5	7	5	7	5	7	5	940016	Nut
11	1	-	1	-	1	-	1	-	950430	Sealing end

8.15 Safety

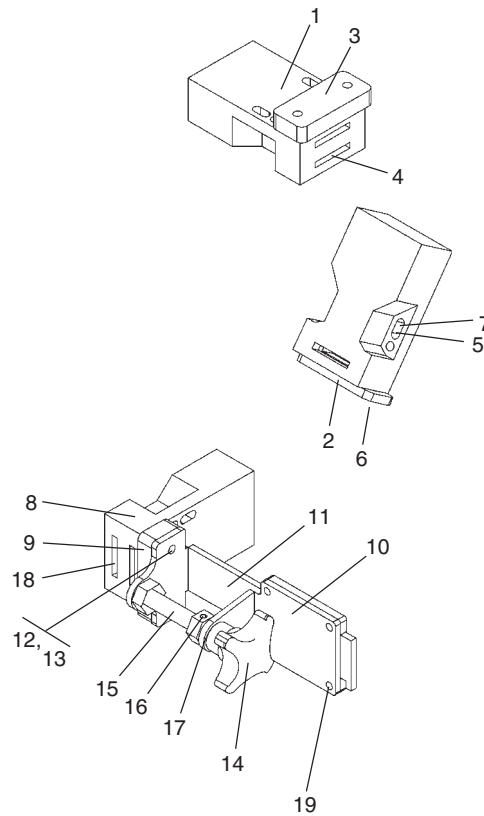

Pos	Qty.				Art. no.	Description	Note
	┌					Granulator 810	
		┌				Granulator 814	
			┌			Granulator 819	
				┌		Granulator 824	
1	2	2	2	2	911862	Switch AZ16-02	
2	1	1	1	1	911003	Key, switch	
3	1	1	1	1	911004	Key, switch	
4	6	6	6	6	911005	Covering washer	
5	4	4	4	4	940076	Socket head screw M5	
6	4	4	4	4	940611	Socket head screw M5	
7	6	6	6	6	940267	Nut M5	
Granulators which have a screen with hole diameter 8 mm or larger, should have an extend security.							
8	1	1	1	1	911862	Switch AZ16-02	
9	1	1	1	1	911004	Key, switch	
10	1	1	1	1	3-34025	Bracket, key	
11	1	1	1	1	3-34024	Slide, key	
12	2	2	2	2	940611	Socket head screw M5	
13	2	2	2	2	940267	Nut M5	
14	1	1	1	1	950393	Star knob	
15	1	1	1	1	940764	Grub screw M10	
16	2	2	2	2	940031	Washer BRB	
17	1	1	1	1	940586	Grub screw M4	
18	3	3	3	3	911005	Covering washer	
19	4	4	4	4	940415	Pop-rivet, aluminium	

8.17 Enclosure, transmission

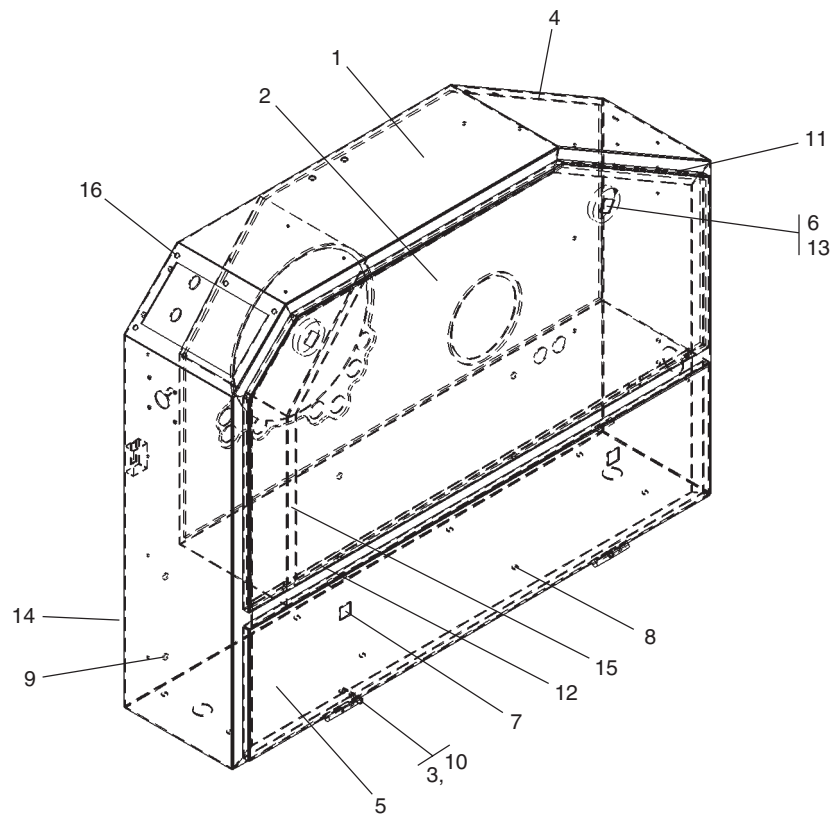

Pos	Qty.	Art. no.	Description	Note
	┌		Granulator 810	
		┌	Granulator 814	
		┌	Granulator 819	
		┌	Granulator 824	
1	1	1-41097	Cover, transmission	
2	1	2-40844	Lid	
3	1	4-30274	Stop, door el	
4	1	4-32350	Noise absorber	
5	1	4-41102	Noise absorber	
6	2	992875	Lock, door lock	
7	2	992876	Lock, door lock	
8	10	940213	Socket head screw M6	
9	6	950321	Nut M6, blind rivet	
10	2	940027	Nut M6	
11	1	950613	List, edge protection	EPDM
12	1	970084	List, edge protection	PVC
13	1	950624	Key	
14	1	992455	List	self-adhering, cell.rubber
15	1	970218	List	self-adhering, EPDM
16	6	950247	Nut M5, blind rivet	

8.18 Body

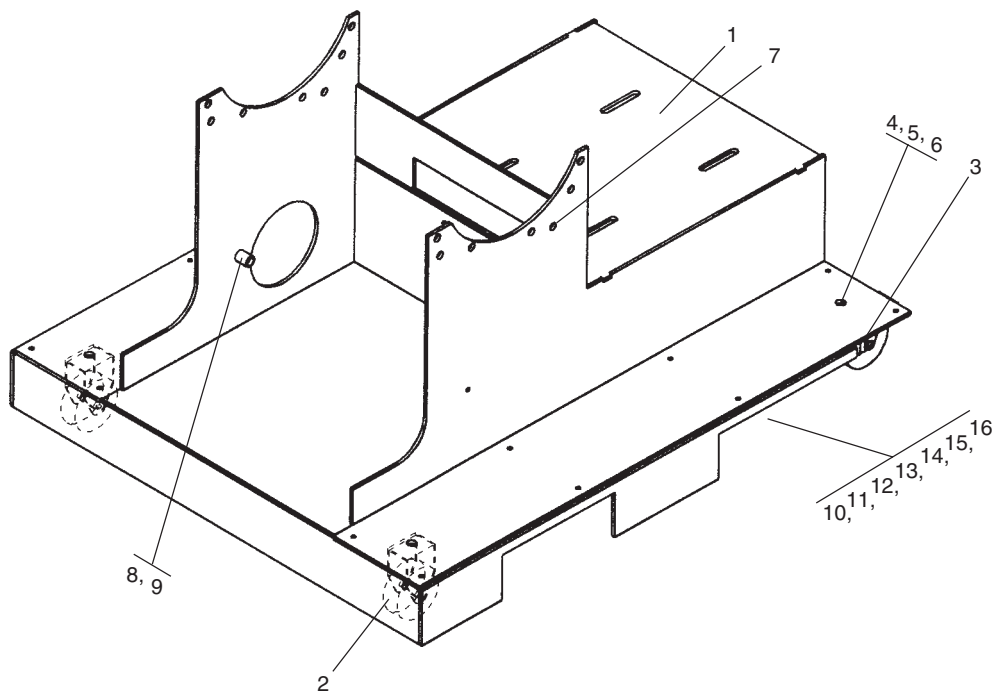

Pos	Qty.				Art. no.	Description	Note
						Granulator 810	
						Granulator 814	
						Granulator 819	
						Granulator 824	
1	1	-	-	-	1-46170	Bottom plate	
	-	1	-	-	1-46171	—"	
	-	-	1	-	1-46172	—"	
	-	-	-	1	1-46145	—"	
2	2	2	2	2	950148	Wheel, fixed	
3	2	2	2	2	950147	Wheel, turnable	
4	4	4	4	4	940051	Socket head screw M12	
5	4	4	4	4	940024	Nut M12	
6	4	4	4	4	40155	Washer BRB	
7	14	14	14	14	940037	Socket head screw M10	
8	2	2	2	2	4-30076	Distance 16/7	
9	2	2	2	2	940104	Socket head screw M6	
10	2	2	2	2	4-46165	Noise absorber	
11	1	-	-	-	4-46166	Noise absorber	
	-	1	-	-	4-46167	—"	
	-	-	1	-	4-46168	—"	
	-	-	-	1	4-46169	—"	
12	1	1	1	1	4-32319	Noise absorber	
13	2	2	2	2	4-32345	Noise absorber	
14	1	-	-	-	4-32313	Noise absorber	
	-	1	-	-	4-32314	—"	
	-	-	1	-	4-32315	—"	
	-	-	-	1	4-44963	—"	
15	1	-	-	-	4-32316	Noise absorber	
	-	1	-	-	4-32317	—"	
	-	-	1	-	4-32318	—"	
	-	-	-	1	4-44964	—"	
16	-	1	-	-	4-32344	Noise absorber	
	-	-	1	-	4-32348	—"	
	-	-	-	1	4-44967	—"	

8.19 Tools, accessories and fixtures

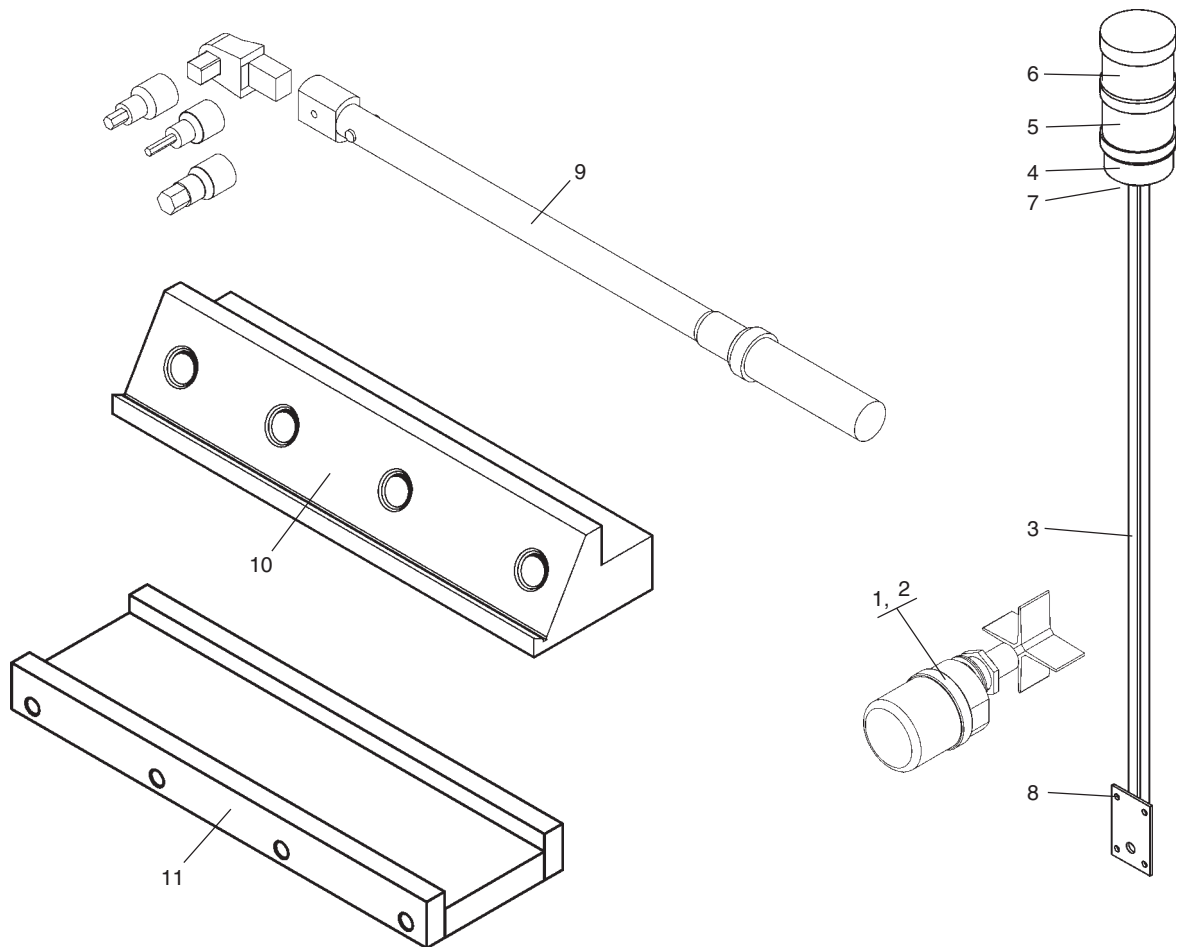

Pos	Qty.	Art. no.	Description	Note
			Granulator 810	
			Granulator 814	
			Granulator 819	
			Granulator 824	
1	1	911105	Paddle monitor	RP-5
2	1	911266	Connector	paddle monitor
3	1	2-40465	Holder,warning	— " —
4	1	911532	Adapter	— " —
5	1	911523	Warning lamp	— " —
6	1	911529	Siren 24 V	— " —
7	2	940408	Socket head screw M4	— " —
8	4	940795	Socket head screw M5	— " —
9	1	3-39559	Torque wrench set	Granulator with 3-step cutter
	1		Torque wrench	
	1		Squarecoupler	
	1		Socket 1/2", 6 mm	
	1		Socket 1/2", 8 mm	
	1	3-39563	Torque wrench set	Granulator with open cutter
	1		Torque wrench	
	1		Squarecoupler	
	1		Socket 1/2", 6 mm	
	1		Socket 1/2", 16 mm	
10	1	3-30324	Grinding fixture, rotating knives	Granulator with open cutter
	-	-	— " —	— " —
	-	-	— " —	— " —
	-	-	— " —	— " —
	2	940435	Washer	stamped
	2	950158	Washer	spherical
	2	950159	Washer	spherical
	2	940762	Cylindric pin	
	2	940674	Socket head screw M16	
11	-	3-04517	Knife pre-setting fixture	Granulator with open cutter
	-	-	— " —	— " —
	-	-	— " —	— " —
	-	-	— " —	— " —

9. Wiring diagram

Never change or modify the basic electrical settings of the granulator, without first obtaining permission from the Conair Main Office.

If the granulator settings are changed, the machine can be seriously damaged.

All warranties and Conair's product liability will be void, if the basic settings of the granulator are changed.

All electrical maintenance and service work, must be done by trained and competent personnel!

Electrical installation must only be done by a competent electrician!

The electrical cabinet of the granulator is located down on right side.

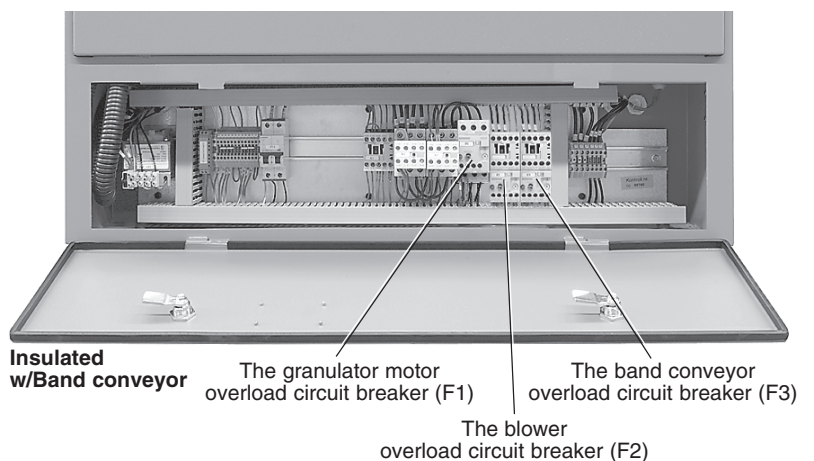
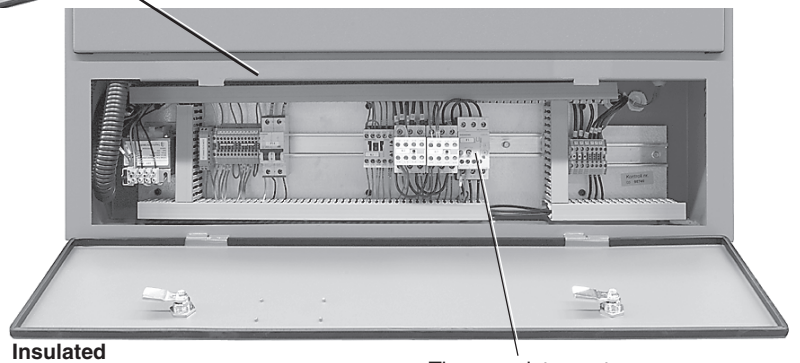
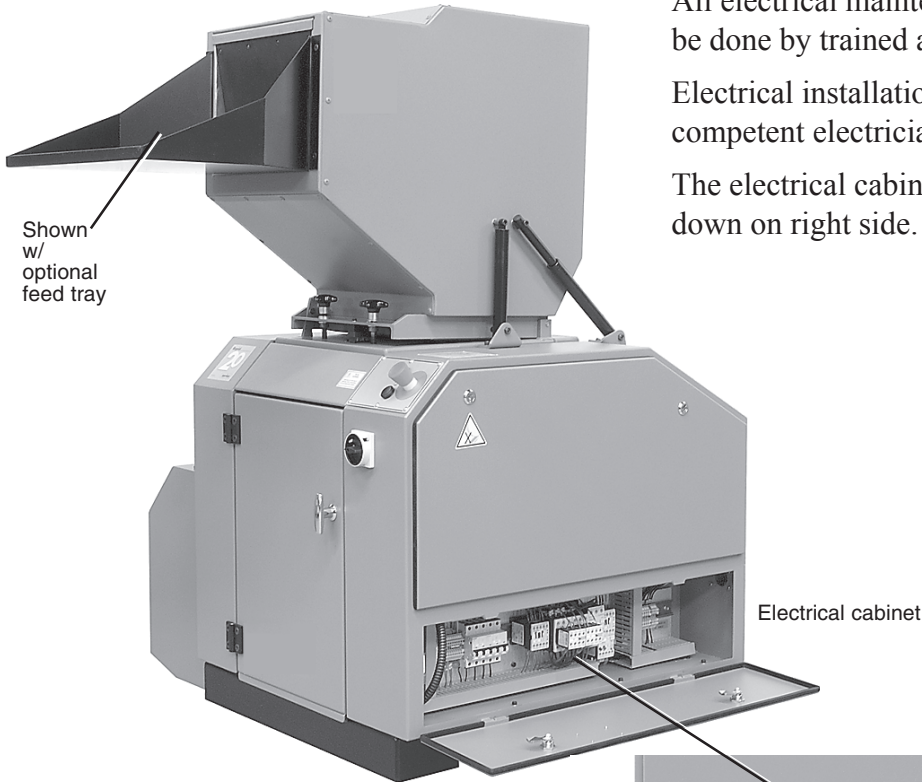

9.1 Current sensing relay "Crouzet"

The granulator can as an option be equipped with a current sensing relay to control the feed equipment.

The current sensing relay sense the granulator motor current consumption and can temporarily stop optional accessories such as conveyors, roller feeders etc. to avoid that further material are fed into the hopper, when the granulator is running under heavy loading.

The relay stops and re-starts optional accessories automatically, without re-setting.

The relay functions and normal settings:

T1 – Reaction time, time delay which prevents the relay from opening during an temporarily high loading (0.1 - 3 sec.).

Normal set reaction time is 3.0 seconds.

T2 – Time delay on starting, which prevents the relay from opening when the granulator is started (0.1 - 10 sec.).

Normal set start delay is 0.1 seconds.

A – Limit value, adjustable between 0 - 100 %.

Normal setting depends on the current transformer size.

Check the current transformer size and then check the normal setting below for this granulator.

B – Hysteresis, adjustable between 5 - 50% of the set limit.

Normal set hysteresis is 20 %.

C – Yellow LED, indication for relay status.

- Lights when everything is OK, i.e. when the current is below the limit value.
- Goes out during alarm.

D – Green LED, indication for control current OK.

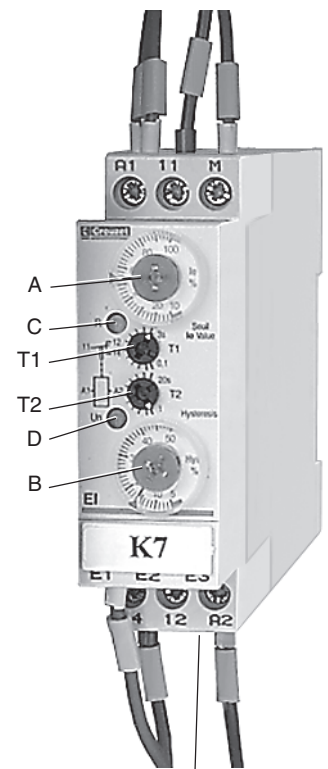

Function choice with or without memory

Connection

The current sensing relay is connected with a current transformer in series with the granulator motor.

The current transformer is connected between M and E1/E2/E3 depending on the secondary current.

(For transformer with transformation to 1A is this connected to E1.)

Set function choice – with or without memory.

– with under-current or excess current.

Setting

By the upper %-setting “A” is the limit value set. The current value at which you want the relay to open. Note that the %-setting control depends on the size of the current transformer and which measurement input are used E1, E2 or E3.

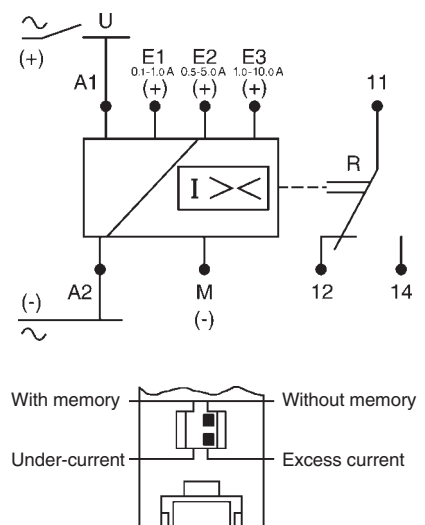

An easy way to find the correct limit value for your granulator, is to have the granulator motor in normal operation, then turn the %-setting control from 100% and down until the relay drops. Then turn the %-setting control back until the limit is just above this level.

The lower %-setting control “B” is used to set the hysteresis level. The level after alarm, when the relay should re-start the feed equipment/conveyor. If the hysteresis wheel control is set at 20%, the relay will re-start the feed equipment when the current has gone down to the limit value plus the hysteresis value of 20%.

“T1” is a time delay, which determines how long time the granulator motor can exceed the set limit value before the relay drops.

“T2” is a time delay, which only is activated when the granulator is started. This time delay prevents the relay from dropping when the granulator is started and when the current usually exceeds the set limit value for the relay.

Function setting with or without memory. When the setting “With memory” is used, the relay does not re-start the granulator’s feed equipment, when the current has fallen to down limit value plus hysteresis value. The relay memory setting must be manually reset.

Normal setting of the function choice is “Without memory”.

Function choice under-current or excess-current. We measure the maximum current used by the granulator, so the selector should be in position “Excess current”.

Normal setting for this: Y/D-started granulator

Granulator motor, rated current: / $\sqrt{3}$ = A
 (recommended fuse in mains \approx min 1.5 x granulator motor rated current)

Current transformer: /1A

Time delay reaction time T1: 3.0 sec. other value:

Time delay on start T2: 0.1 sec. other value:

Limit value: % = A

Hysteresis: % = A

Function choice: with memory without memory under current excess current

Direct-started granulator

..... = A
 (use 2 x granulator motor rated current)

..... /1A

3.0 sec. other value:

0.1 sec. other value:

% = A

% = A

Example

The granulator is equipped with a current sensing relay to control a conveyor.

A motor of 10 Hp {7.5 kW} has a rated current of about 15 A.

At full load the granulator consumptions approx $15 A/\sqrt{3}$ i.e. app. 8.7 A per phase.

Relay setting: Y/D-started granulator Direct-started granulator

Motor size $15 A/\sqrt{3}$ = 8.7 A/phase = 15 A

- T1 – Set reaction time is 3.0 seconds.
- T2 – Set start delay is 0.1 second.
- A – Limit value 29 %. See calculation on next page.
- B – Hysteresis 20 %.
- C – Yellow LED lights, the current is below limit value.
- D – Green LED lights.

Function choice in position without memory.

The current transformer size is 30/1A.

The current transformer is connected to E1 (1 A).

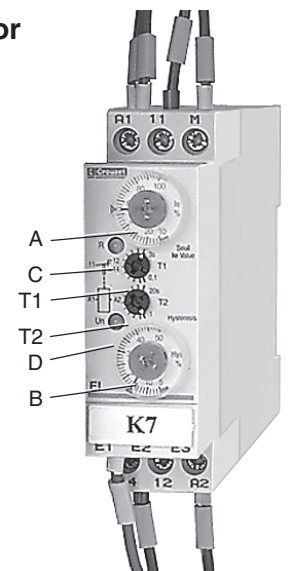

On a current sensing relay with a current transformer which have a transformation ratio of 30/1, the limit value “A” should be set to 29 % corresponding 8.7 A (30 A = 100 %).

On a Y/D-started granulator which only have one leader which passing through the center hole in the transformer:

Calculate with the current in one phase: $\frac{8.7}{30} \times 100 = 29\%$

If 2 leader passing through the center hole in the transformer: $\frac{15}{30} \times 100 = 50\%$
Calculate with the whole motor current.

A direct-started granulator have allways 1 leader through the center hole.

For an direct-started granulator with rated current 15A is the calculation: $\frac{15}{30} \times 100 = 50\%$

The current sensing relay sense the current consumption of the granulator motor and stops the conveyor, when the granulator motor consumption exceeds 8.7 A for 3 seconds, to prevent that further material are being fed into the hopper.

The Yellow LED flashes when the current exceeds the set limit value, and goes out when the conveyor stops. The Green LED lights.

The relay re-starts the conveyor automatically, when the granulator motor consumption has fallen 20 % below 8.7 A, i.e. to 7 A without a time delay. Yellow and Green LEDs light.

10. Layout

3-29744; CLS/CHS, not sound encapsulated, hopper "K" with front feed table

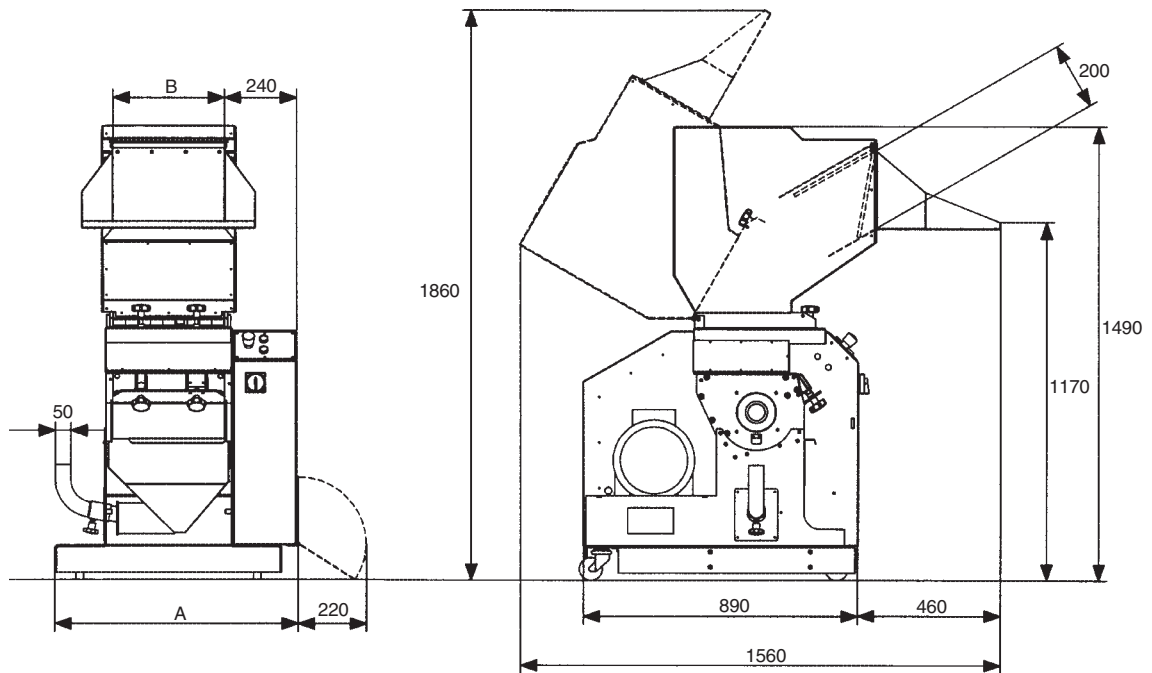

	810	814	819	824
A	670	790	910	1030
B	240	360	480	600

3-31694; CLS/CHS, not sound encapsulated, hopper "K" with front funnel

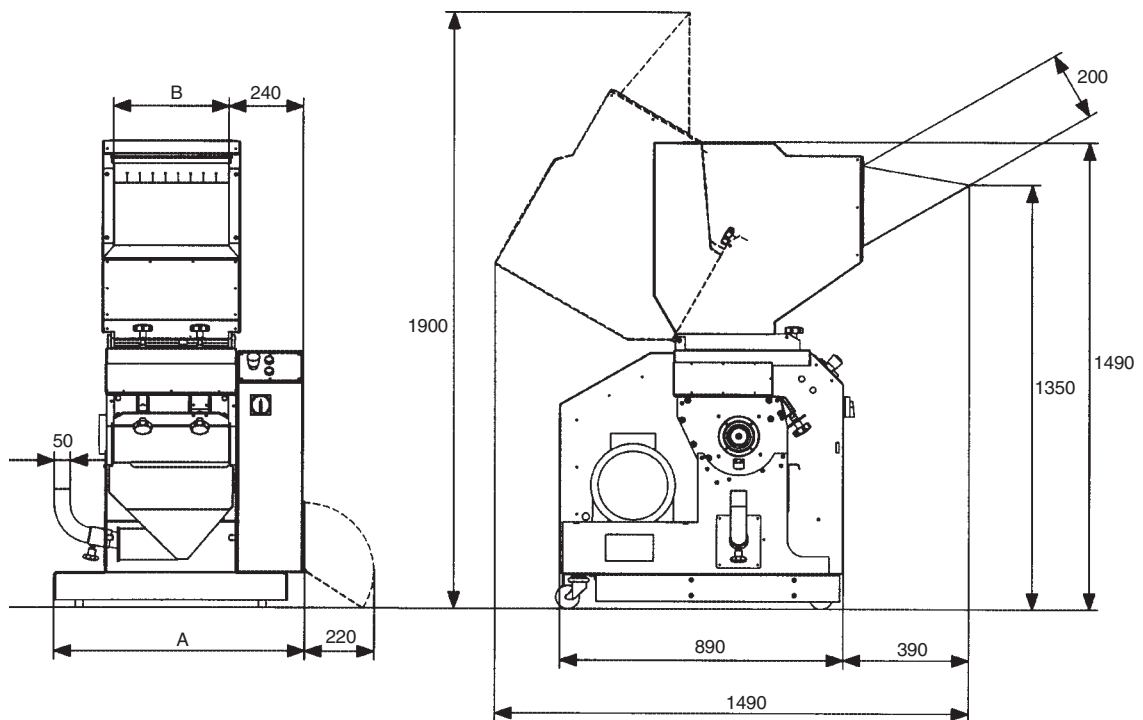

	810	814	819	824
A	670	790	910	1030
B	240	360	480	600

3-31696; CLS/CHS, not sound encapsulated, hopper "K" with front feed table, blower F-7, cyclone AX-7,5 with holder/bag holder

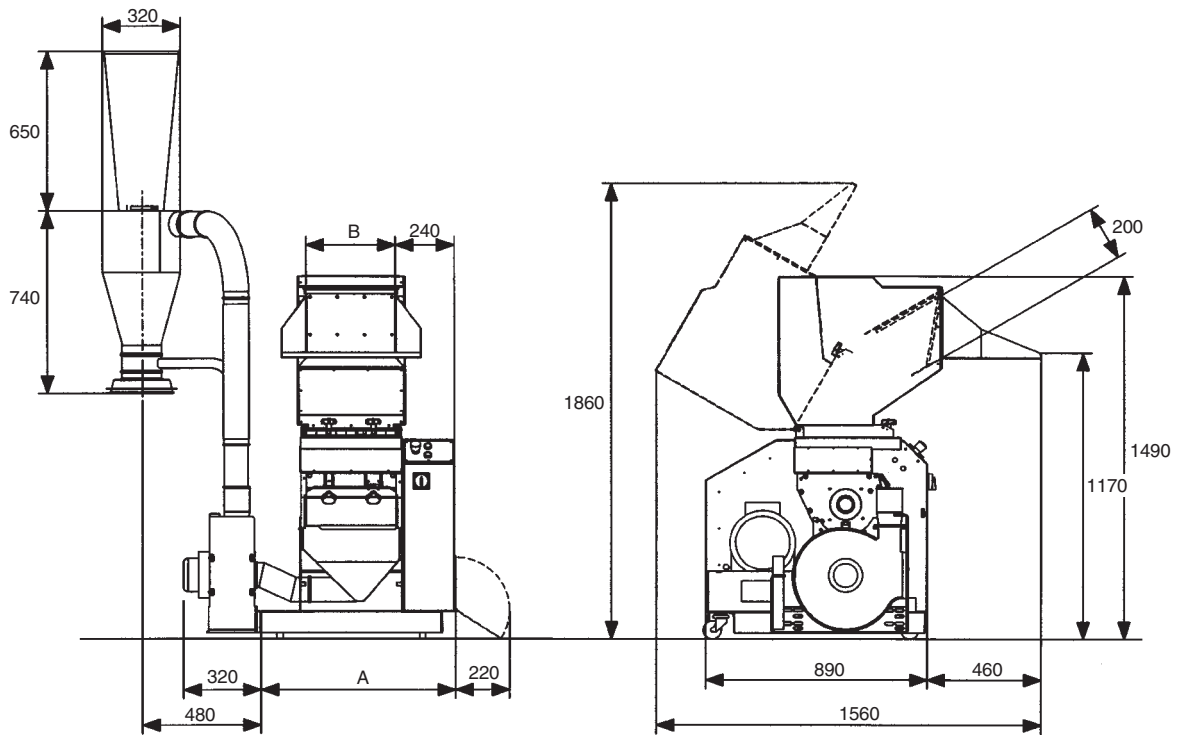

	810	814	819	824
A	670	790	910	1030
B	240	360	480	600

3-30496; CLS/CHS, sound encapsulated, hopper "K" with front feed table

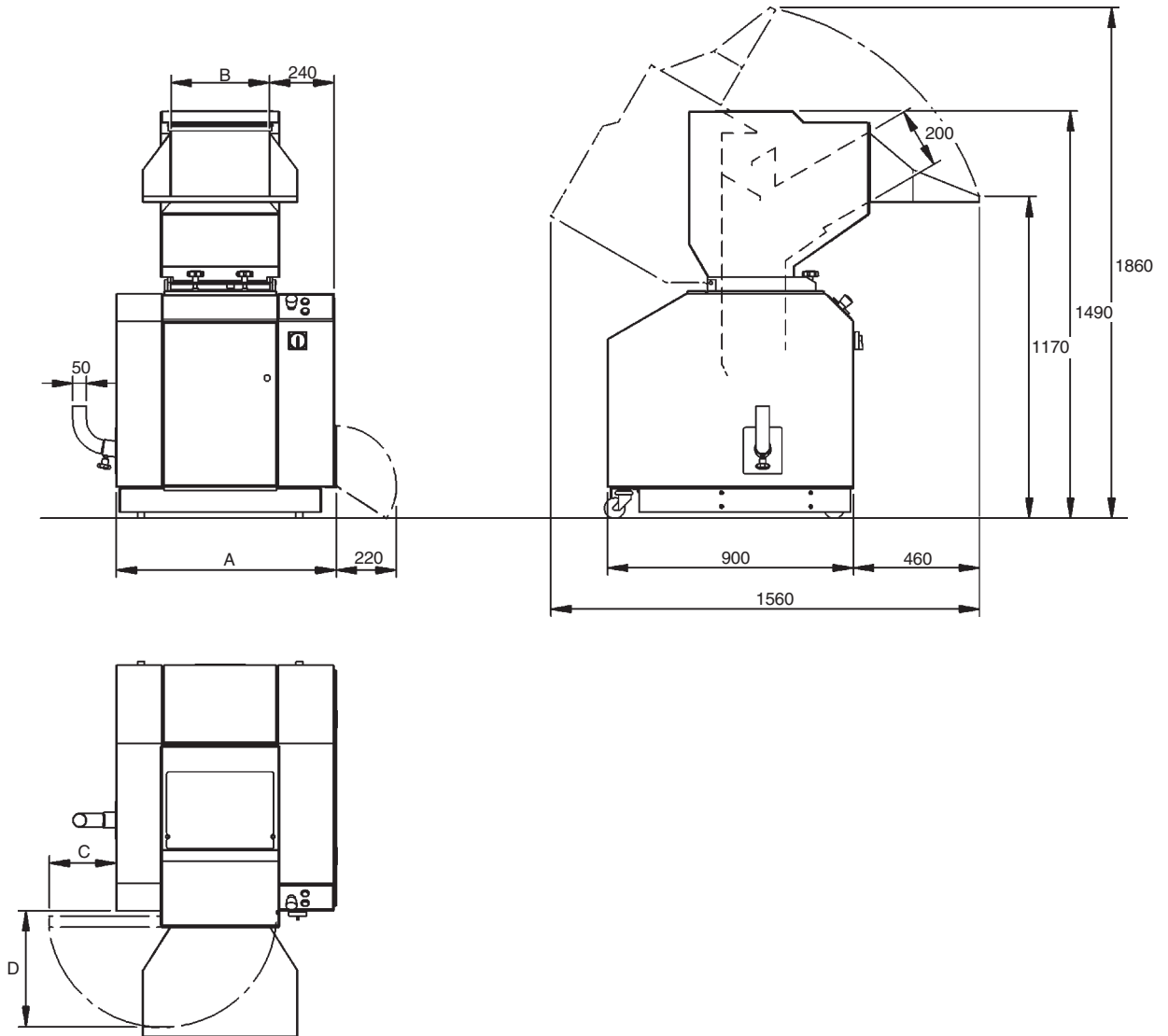

	810	814	819	824
A	680	800	920	1040
B	240	360	480	600
C	130	250	370	490
D	310	430	550	670

3-31698; CLS/CHS, sound encapsulated, hopper "K" with front funnel

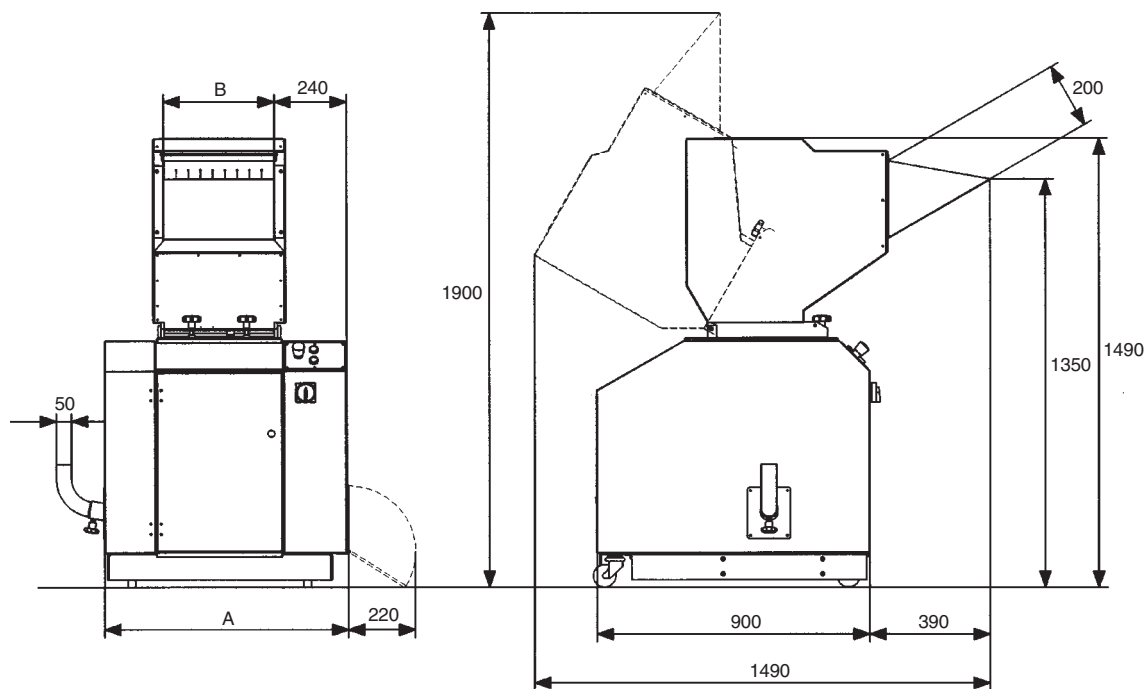

	810	814	819	824
A	680	800	920	1040
B	240	360	480	600

3-31801; CLS/CHS, sound encapsulated, hopper "K" with front feed table, blower F-7 and cyclone AX-7,5 with holder/bag holder

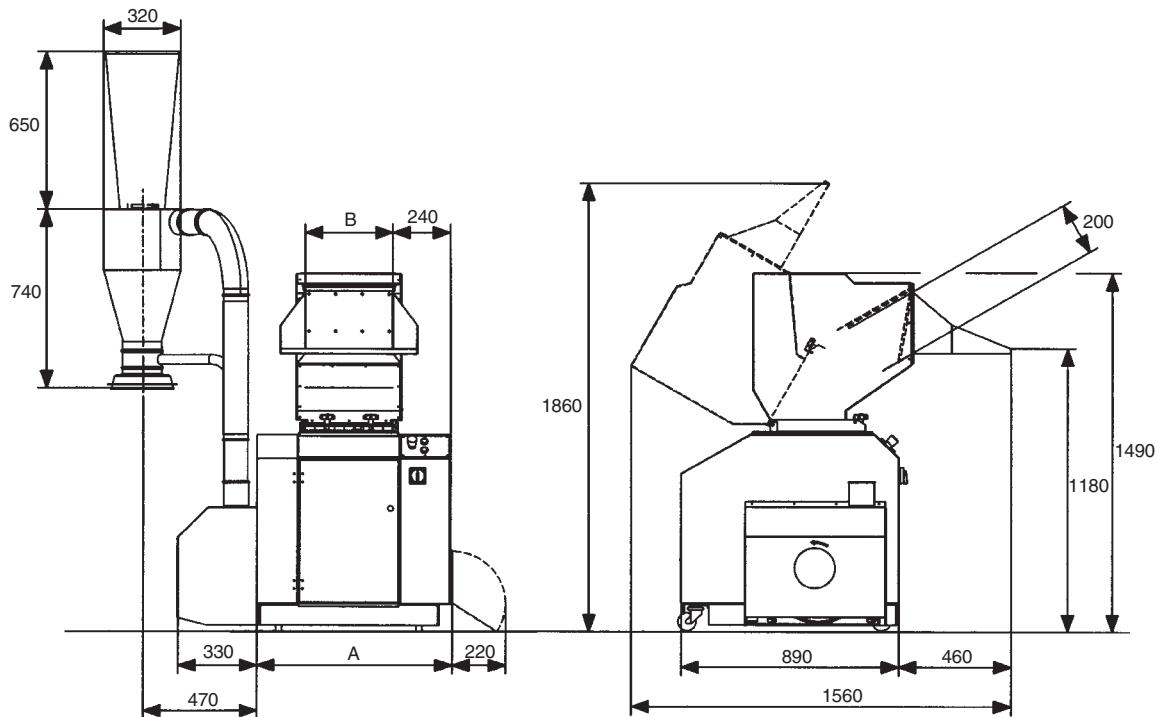

	810	814	819	824
A	680	800	920	1040
B	240	360	480	600

3-31695; CLS/CHS -KB, not sound encapsulated, hopper “K” with front funnel and band conveyor “B”

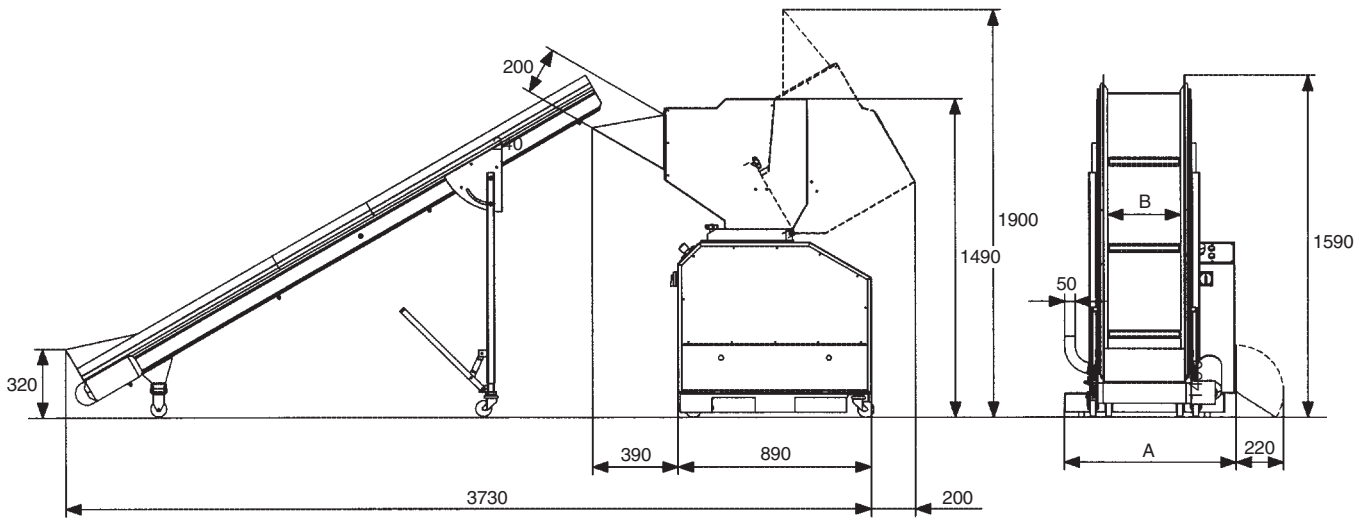

	810	814	819	824
A	670	790	910	1030
B	180	330	430	580

3-31699; CLS/CHS -KB, sound encapsulated, hopper “K” with front funnel and band conveyor “B”

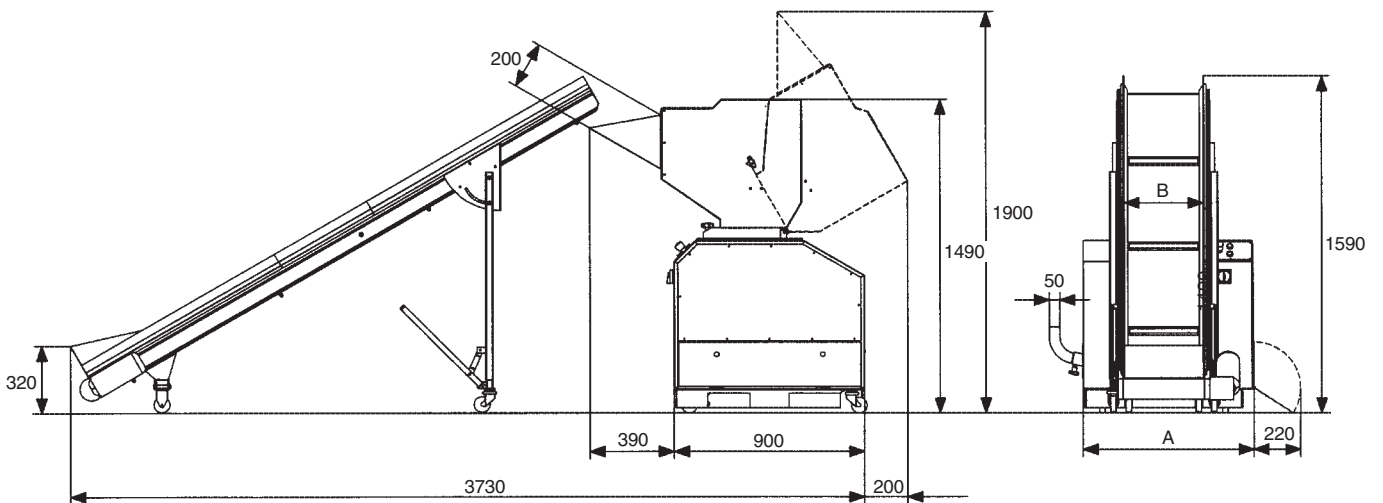

	810	814	819	824
A	680	800	920	1040
B	240	360	480	600

3-31697; CLS/CHS -KB, not sound encapsulated, hopper "K" with sound trap and band conveyor "B"

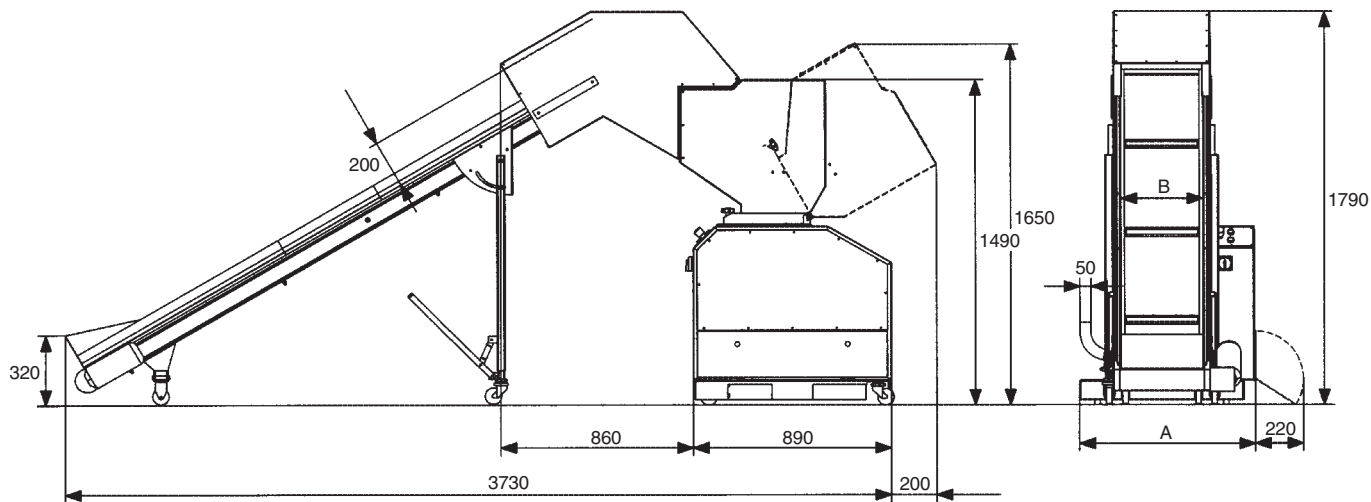

	810	814	819	824
A	670	790	910	1030
B	240	360	480	600

3-34211; CLS/CHS -KUB, sound encapsulated, hopper "K" with sound trap, band conveyor "B", blower F-7 and cyclone AX-7,5

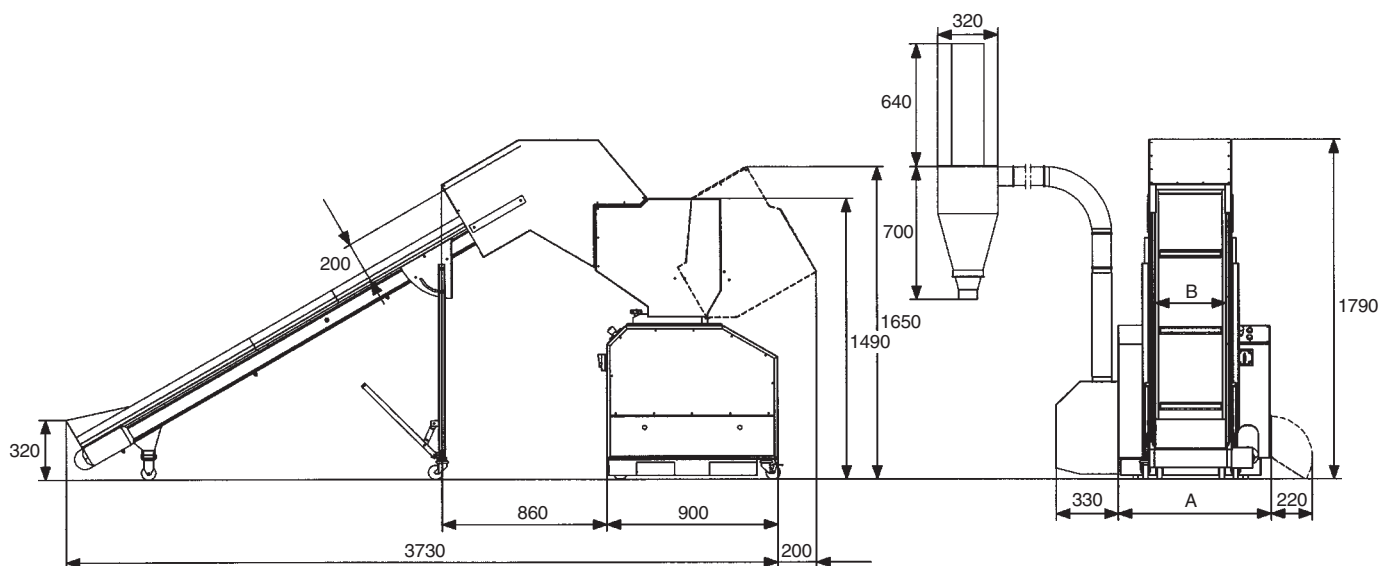

	810	814	819	824
A	680	800	920	1040
B	240	360	480	600

3-29628; CLS/CHS -KP, not sound encapsulated, hopper "P" adapted for feeding profiles

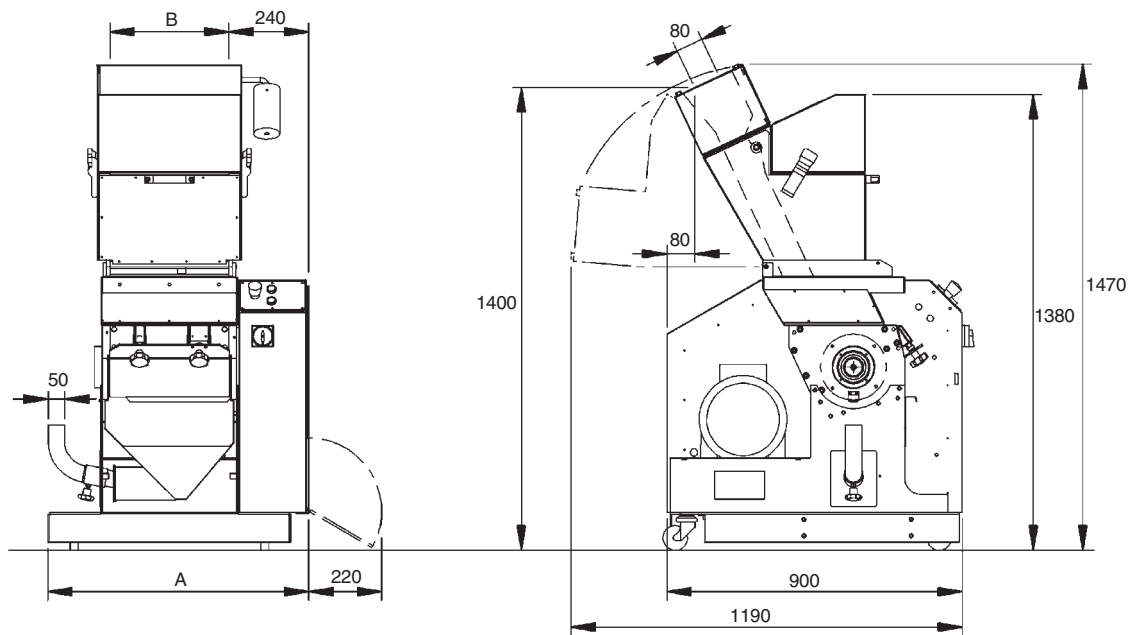

	810	814	819	824
A	670	790	910	1030
B	240	360	480	600

3-48067; CLS/CHS -KUP, sound encapsulated, hopper "P" adapted for feeding profiles, blower F-7 and cyclone AX-7,5

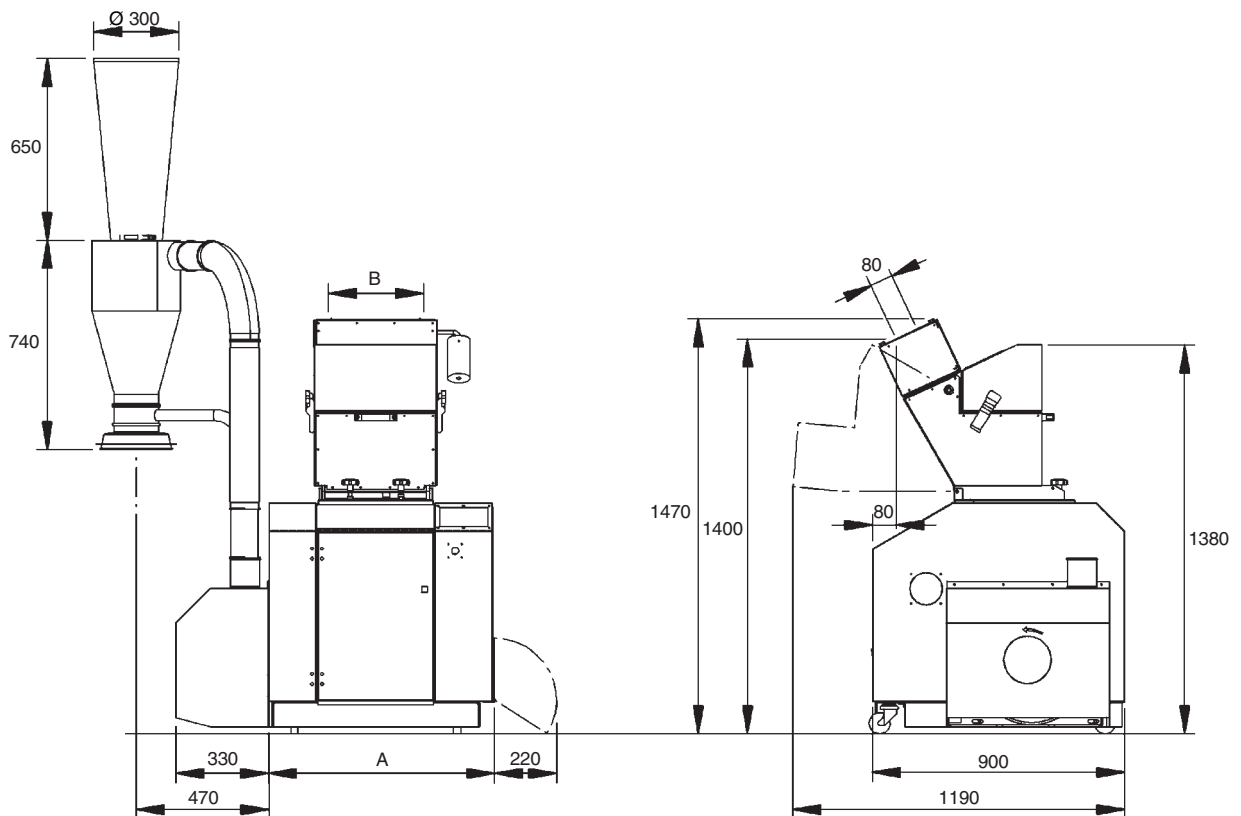

	810	814	819	824
A	680	800	920	1040
B	240	360	480	600

11. Options

Overview

The granulator's accessories is divided into the following modules:

	Page
11.1 Pre-setting of rotating knives, granulator with open cutter	11:2
– Setting up the knives	11:2
– Installation of pre-set knives	11:2
11.2 Third fixed counter knife	11:3
– Removing	11:3
– Installation	11:3
11.3 Blower F-7 and F-15	11:4
– Safety	11:4
– Installation	11:4
– Maintenance	11:4
– Spare parts	11:5
11.4 Level monitor	11:6
– Setting the paddle monitor sensitivity	11:6
11.5 Band conveyor	11:7
– Safety	11:7
– Installation	11:7
– Electrical connection	11:7
– Start	11:7
– Maintenance	11:8
– Fault finding	11:8
– Spare parts to band conveyor	11:9

Ordering spare parts

Only use original Conair spare parts when replacing machinery components.

Orders should be sent to the representative in the country where the machine was purchased.

When ordering spare parts, please specify:

- Machine type/designation, on the machine's rating plate.
- Serial number, on the machine's rating plate.
- Part number, from this list of spare parts.
- Number of components.

11.1 Pre-setting of rotating knives, granulator with open cutter

Pre-setting of rotating knives can only be done on granulators with open cutter.

The knives are pre-set in a pre-setting fixture.

The pre-setting fixture is not included in the delivery of the machine, but it is a very practical accessory.



Setting up the knives



NOTE! The knives must be grinded before pre-setting.

The pre-setting fixture is on machine delivery calibrated against the welded set screws in the cutter's knife positions.

The pre-setting fixture gives the correct knife clearance 0.15 - 0.25 mm.

- Screw the adjustment screws somewhat in on the rotating knives.

Pre-set one rotating knife at a time.

- Put knife in the pre-setting fixture, with the knife edge downwards.
- Put an feeler gauge 0.15 mm between the adjustment screws and the rear edge in the fixture.
- Screw out the adjustment screws until the feeler gauge begins to bind.
- The pre-setting is now completed and the knife can be installed in the cutter.

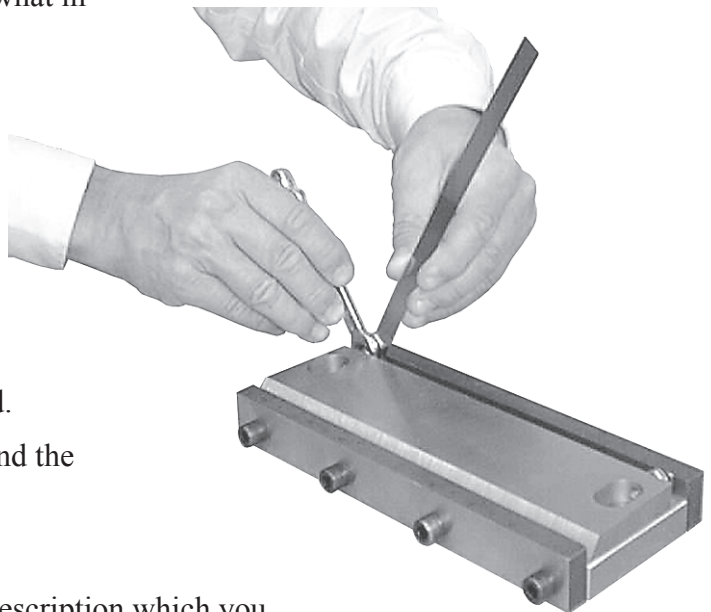

Installation of pre-set knives

Read and install the knives as per the description which you can find in chapter 7, in this instruction manual.

Note!



The rotating knives to a granulator with a open cutter should be installed by using a torque wrench and a tightening torque of 220 Nm.



Each time the set of knives is changed and every second time re-sharpened knives are installed, the screws and the washers which retain the knives must be replaced by new ones.

11.2 Third fixed counter knife

As an optional equipment can the granulator be equipped with a third fixed counter knife to increase the efficiency of the granulator.

Conair's CLS/CHS granulator is an advanced granulator. The type of cutter housing can sub-sequently be adapted to new applications by changing the rear side of the cutter housing.

This is an precision work which must be done by Conair's service department, with the object of maintaining accuracy and tolerances (cutter, knives, knife positions, presetting sizes, etc).

Please contact Conair's local agent or Conair's main office.

Characteristics of the 3rd fixed counter knife

The knife is turnable.

The granulator's 3rd fixed knife is turnable and two cutting edges can be used.

The knife can not be grinded.

The granulator's 3rd fixed knife can not be re-sharpened, the knife is of disposable type and should be replaced when necessary.

Removing

For to remove/install the tird fixed knife:

- open the hopper.
- "CLS/CHS-K", undo and remove the rear protective cover above the motor and open the door.

The third fixed knife is fastened by a support rule.

1. Undo and remove the screws "A" which fasten the support rule "C" and the knife "B".
2. Remove the knife and the support rule.

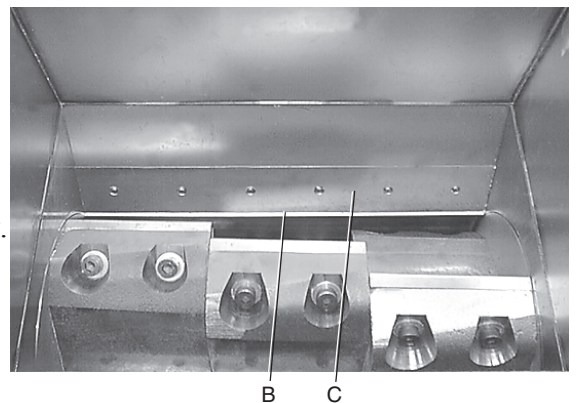

Installation

1. Clean the knife attachment where the knife was located.

The knife attachment must be free from oil grease and dirt.

2. Clean the knife properly.

The knife must be free from oil grease and dirt.

3. Install the knife in knife attachment.
4. Screw in the socket head screws "A" until the support rule "C" lightly supports the knife.
5. Press the knife firmly into stop in the knife attachment.

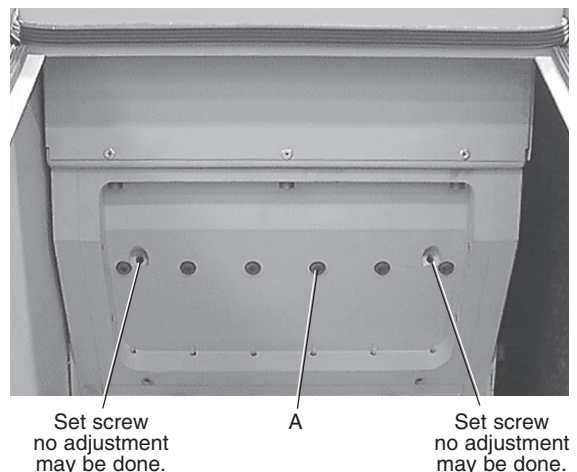

NOTE! The set screws in rear of knife attachment are bonded in place, no adjustment may be done.

NOTE! The knife has a fixed measure and no adjustment may be done.

6. Tighten the screws "A", with an alternating tightening torque to 40 Nm.



11.3 Blower F-7 and F-15

Conair's blowers F-7 and F-15 are intended for dust- and material conveying.



NOTE! The temperature of the conveyed material must never exceed 80°C.

It is not permitted to use the blowers in surroundings where the temperature exceeds 40°C or goes below -20°C.

It is not permitted to rebuilt, modify or use the blowers in explosive atmospheres.

F-7 and F-15 are available with or without sound-insulated encapsulation.

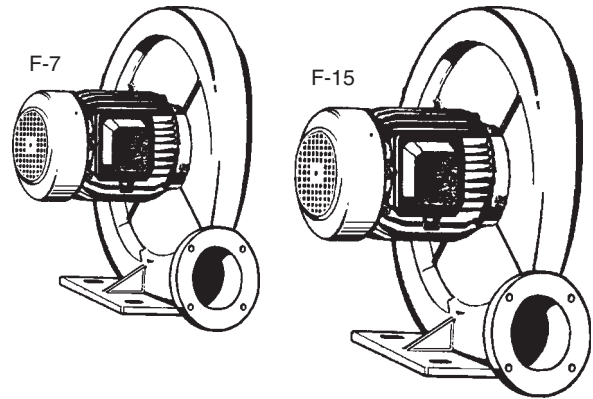

Safety

The following safety advice must be observed, to avoid personal injury, damage to peripheral equipment and to the fan itself.

It is not permitted to use the blowers in humid environments or unprotected outdoors.



WARNING! F-7 and F-15 have high suction power.

The blowers F-7 and F-15 must therefore never be used with an unprotected inlet opening. Objects and clothing can easily be sucked in to the blower inlet and cause personal injury.



WARNING! F-7 and F-15 produce a powerful stream of air at the discharge opening.

NOTE! The stream of air from the discharge opening is powerful. Granulate and objects which have been sucked in to the blower, will be thrown out at very high speed and can cause personal injury. Never put a hand directly in front of the blower discharge opening.



Electrical connection

Electrical connection must only be done by a competent electrician.

Sound level

The sound pressure level is not the same at different blower speeds. If a blower is used without a sound-damping housing, recommends that ear protections are used to avoid damage to hearing.

Installation

Check that the blower does not have any transport damage before installation and commissioning.

Arrangements and mounting

It is not permitted to use the blower in humid environments or unprotected outdoors.

Before the blower is taken into service, check that the blower impeller rotates freely and does not have any imbalance.

Install a protective grating on the exhaust opening.

Make sure that the electrical motor is provided with sufficient ventilation, the maximum permissible ambient temperature is 40°C.

Maintenance

The blower has enclosed ball bearings lubricated for life and can not be lubricated later on.

For any repair or maintenance please contact the local Conair distributor or the Conair main office.

Spare parts

11.3.1 Blower F-7

Pos	Qty.	Art. no.	Description
1			Blower F-7, complete
2	1		Blower housing
3	1		Impeller
4	1		Side, inlet
5	1		Motor
6	1		Motor cover

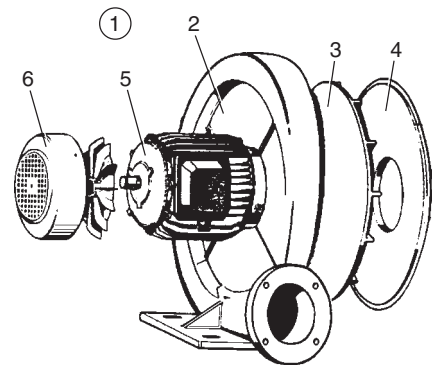

11.3.2 Blower F-15

Pos	Qty.	Art. no.	Description
1			Blower F-15, complete
2	1		Blower housing
3	1		Impeller
4	1		Side, inlet
5	1		Motor
6	1		Motor cover

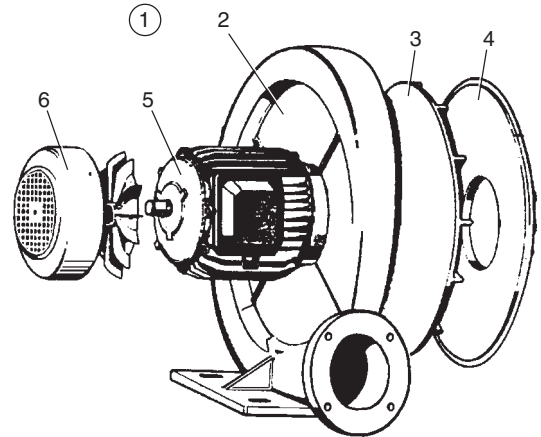

11.4 Level monitor

The granulator can as an option be equipped with a level monitor of the type paddle monitor.

The paddle monitor senses the level of granulate in granule bin and gives alarm, or alternative stops the granulator and the granulator's feed equipment such as band conveyor etc. when the level of granulate in the granule bin rises too high.

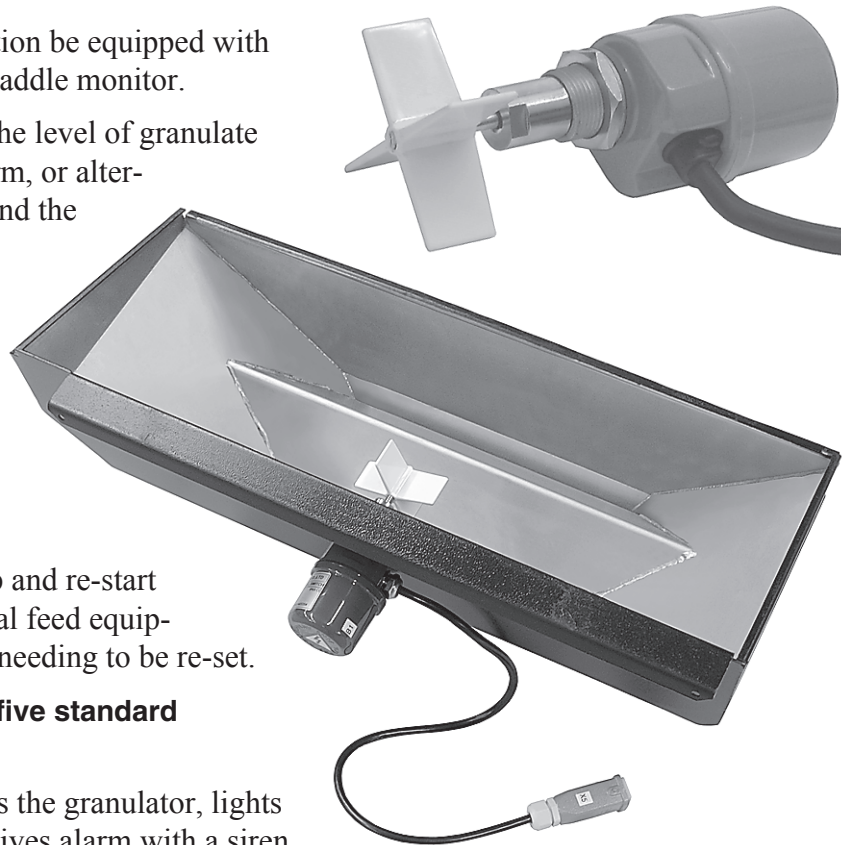

The paddle monitor can stop and re-start the granulator, or the optional feed equipment automatically without needing to be re-set.

The Paddle monitor have five standard connections:

1. The paddle monitor stops the granulator, lights up a warning lamp and gives alarm with a siren.
2. The paddle monitor stops the granulator and lights up a warning lamp.
3. The paddle monitor stops the granulator.
4. The paddle monitor lights up a warning lamp and gives alarm with a siren.
5. The paddle monitor lights up a warning lamp.

Setting the paddle monitor sensitivity

The sensitivity of the paddle monitor is adjustable.

- Open, unscrew and remove the cover over the paddle monitor's microswitches.
- Change the position of the torsion spring.

Use a needle-nosed pliers to change the spring position.

The normal setting of the torsion spring is the 2:nd hole from the left.

Reduce the paddle monitor sensitivity:

- Move the torsion spring to the left. (The paddle monitor breaks later).

Increase the paddle monitor sensitivity:

- Move the torsion spring to the right. (The paddle monitor breaks earlier).

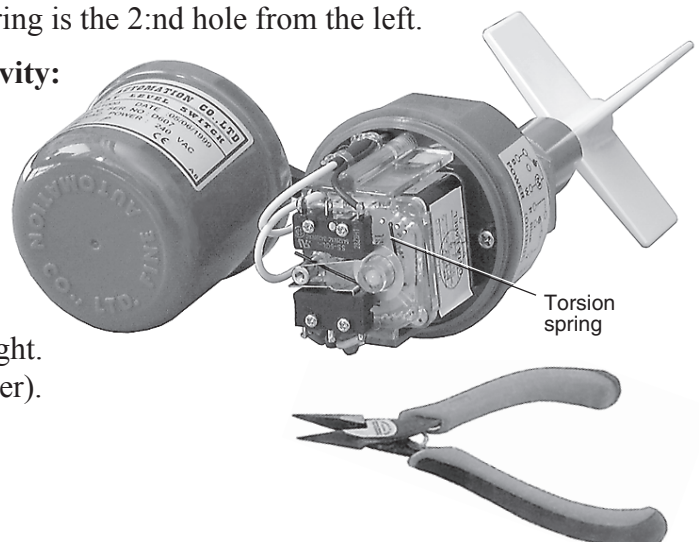

11.5 Band conveyor

The band conveyor is designed for transporting plastic waste. The conveyor is constructed by frame beams assembled with cross sections and screws.

The band conveyor can be equipped with a metal detector.

Safety

During all maintenance work on the band conveyor, the connector should be removed from socket outlet on the granulator! Alternatively, the main switch must be in position “Off” and with the turn knob locked.

The conveyor is designed for plastic waste. Do not use the conveyor for tasks other than it is intended for.

Nobody may ride on the conveyor, or step on it during operation.

If the conveyor has stopped due to an error, or emergency stop, it must not be re-started before the cause has been established and the appropriate action has been taken.

Mobile conveyors must always be transported in downfolded position.



Warning! When using transport band with carriers. Be careful so that the carriers not catching any clothing, arm or foot.

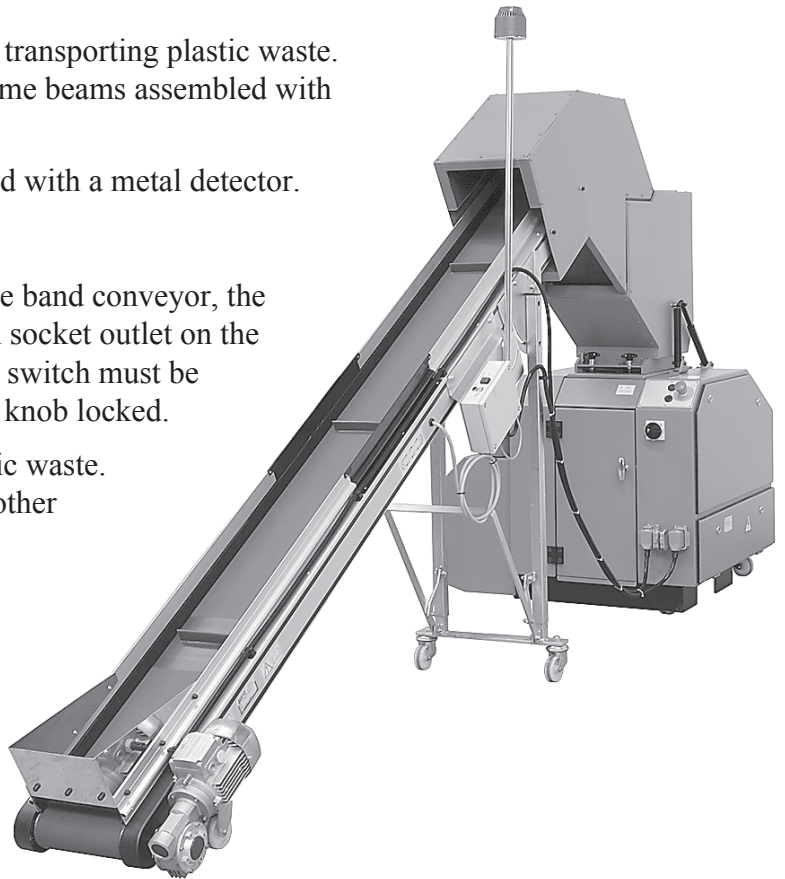

Installation

When installing, adjust the stand until that the band conveyor stands horizontal diagonally.

If floor on the place of use is very uneven, it should be made even before installation.

Electrical connection



The band conveyor must only be connected by an authorised electrician.

Connect the band conveyor by using a connector to the socket outlet on the granulator.

Switch on the main switch on the granulator. Press the start button and check that the band moves in correct direction.

If the band moves in the wrong direction.

Read chapter 5.3 “Electrical connection” in this instruction manual.

First check that the granulator is connected to a right turning phase sequence and that the granulator motor have the correct rotation direction.

If the granulator motor have correct rotation direction and the electrical connection is correct:

- shift two phases in the connector to the band conveyor.

Start

When the band conveyor is started for the first time, the transport band’s position on the rollers should be checked. The transport band must not move obliquely!

If the transport band moves obliquely.

Move and make the band conveyor free from the granulator.

Undo the two socket cap screws which holds the covers above the turning roller and remove the covers.

Undone the locking nuts to the adjusting nuts.

Screw/adjust only one adjusting nut at a time.

Screw only a 1/4 of a turn.

Wait and let the band run for a few minutes.

Check, adjust, wait and check again, until the band runs straight.

The band's tension.

The conveyor band's length has 1% tolerance. Tension never the band's adjusting nuts with a greater tightening torque than 5 Nm.

When the adjustment of the band is finished, stop the band conveyor, lock the setting with the locking nuts and replace the covers.

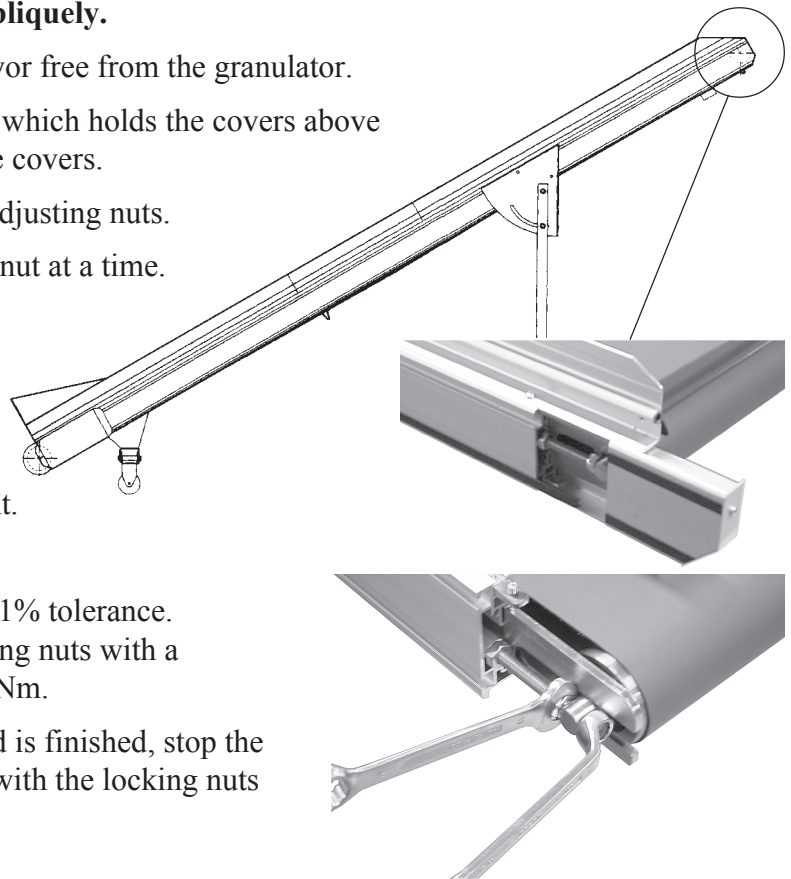

Maintenance

During all maintenance work on the band conveyor, the connector should be removed from socket outlet on the granulator! Alternatively, the main switch must be in position "Off" and with the turn knob locked.

Check regularly the transport band's wear and it's position on the rollers.

The transport band must never move obliquely! Adjust when necessary according to the instructions under: "Start – If the transport band moves obliquely", see previous chapter.

Clean the band using a light cleaning agent. Don't use any sharp objects, strong cleaning agents or chemicals, it can damage the band.

Fault finding

If the band conveyor does not start

Check the overload circuit breaker for the band conveyor.

The band conveyor have an overload circuit breaker F3 in the electrical cabinet which trips, if you run to stop or overload the transport band.

This is indicated in the window A which shows "0".

Reset, Press the knob "Reset".

Check also the granulator's wiring diagram, additions and modifications can occur.

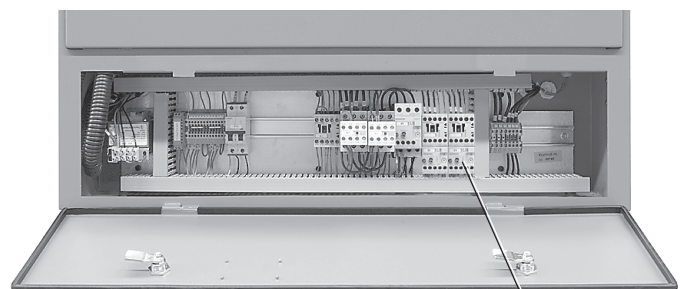

The band conveyor's overload circuit breaker (F3)

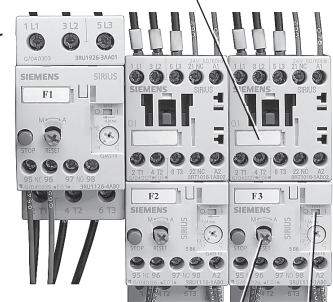

Reset, press the knob "Reset" A

Spare parts for band conveyor

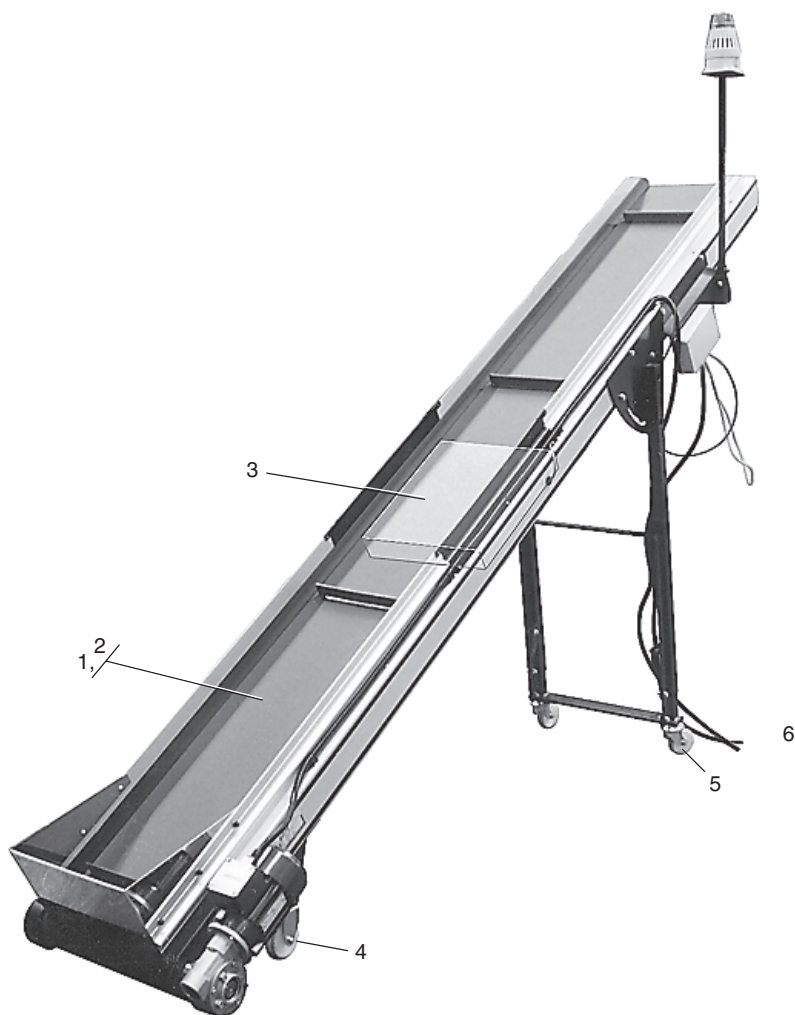

Pos	Qty.								Art. no.	Description	
		┌							3-30648	Band conveyor B200 CC2700	810
			┌						3-	Band conveyor B200 CC2700 MD200P	- " - (metal detector)
				┌					3-30650	Band conveyor B350 CC2700	814
					┌				3-	Band conveyor B350 CC2700 MD350P	- " - (metal detector)
						┌			3-30652	Band conveyor B450 CC2700	819
							┌		3-	Band conveyor B450 CC2700 MD450P	- " - (metal detector)
								┌	3-	Band conveyor B000 CC0000	824
								┌	3-	Band conveyor B000 CC0000 MD000P	- " - (metal detector)
1	1								2-30649	Band conveyor	
									2-30651	- " -	
									2-30653	- " -	
2								1	2-30648	Band conveyor	for metal detector
									2-30650	- " -	- " -
									2-30652	- " -	- " -
3								1	910964	Metal detector	MD200
									911214	- " -	MD350
									910963	- " -	MD450
										- " -	MD000
4	2	2	2	2	2	2	2	2	950412	Wheel, fixed	
5	2	2	2	2	2	2	2	2	950411	Wheel, turnable	
6	1	1	1	1	1	1	1	1	911006	Connector 6-pol	

12. Transport, lift and storage

The machine should be transported by trained personnel.

The machine is delivered packed in protective plastic foil, fixed to a transport pallet with tightening straps.

Unpacking and receiving inspection



- Check that the machine has not been damaged during transport.

NOTE! Report any damage to the forwarding agent.

- Do not unpack the machine before it has been transported to the place it is going to be used.
- Check with the delivery note that the delivery is complete.

Lift and transport to place of use

The machine weighs incl. packaging, approx. 1036 - 1808 lbs {470 - 820 kg}, see also “Technical specification”, chapter 2.

Space requirements, see Layout, chapter 10.

The machine can be lifted and handled with a pallet-lift truck.

The lower part of the machine has on the right-hand side two openings which accommodate a pallet-lift truck.

Drive in a pallet-lift truck as far as possible (to stop), and then lift the machine.

Positioning and installation in place of use

Read chapter 5 “Installation”.

Storage

The machine is packed for transport to the place where it is to be used.

On delivery it is protected with Castrol DWX 22 anti-rust oil.

Long-term storage/Conservation

- Store the machine in a room with a stable, dry temperature.
- Treat the unpainted surfaces of the machine with rust preventer, such as Castrol DWX 22.

DWX 22 will protect the machine up to 12 months, alternatively

DWX 160 which will provide protection for 24 - 36 months.





13. Service and maintenance schedule

Read the instruction manual before maintenance and service.

All maintenance and service must be done by trained personnel.

If you have any questions, please contact the local Conair distributor or the Conair main office.

Local distributor:
.....
.....

Main office: CONAIR
One Conair Drive
Phone. 412-312-6000; Fax. 412-312-6227

Machine data

Machine type: Serial number: Year manufactured: 20
Motor: V. Hz. kW Wiring diagram:

Safety, maintenance and service

Contact person responsible for granulator safety, maintenance and service

Name:	Phone:	Name:	Phone:
.....
.....
.....
.....

Knife changing

..... /	20	<input type="checkbox"/> Rotating knives	<input type="checkbox"/> Fixed counter knives	<input type="checkbox"/> New screws	<input type="checkbox"/> Re-check 2 - 4 h.	Sign:
Note:							
..... /	20	<input type="checkbox"/> Rotating knives	<input type="checkbox"/> Fixed counter knives	<input type="checkbox"/> New screws	<input type="checkbox"/> Re-check 2 - 4 h.	Sign:
Note:							
..... /	20	<input type="checkbox"/> Rotating knives	<input type="checkbox"/> Fixed counter knives	<input type="checkbox"/> New screws	<input type="checkbox"/> Re-check 2 - 4 h.	Sign:
Note:							
..... /	20	<input type="checkbox"/> Rotating knives	<input type="checkbox"/> Fixed counter knives	<input type="checkbox"/> New screws	<input type="checkbox"/> Re-check 2 - 4 h.	Sign:
Note:							
..... /	20	<input type="checkbox"/> Rotating knives	<input type="checkbox"/> Fixed counter knives	<input type="checkbox"/> New screws	<input type="checkbox"/> Re-check 2 - 4 h.	Sign:
Note:							
..... /	20	<input type="checkbox"/> Rotating knives	<input type="checkbox"/> Fixed counter knives	<input type="checkbox"/> New screws	<input type="checkbox"/> Re-check 2 - 4 h.	Sign:
Note:							
..... /	20	<input type="checkbox"/> Rotating knives	<input type="checkbox"/> Fixed counter knives	<input type="checkbox"/> New screws	<input type="checkbox"/> Re-check 2 - 4 h.	Sign:
Note:							
..... /	20	<input type="checkbox"/> Rotating knives	<input type="checkbox"/> Fixed counter knives	<input type="checkbox"/> New screws	<input type="checkbox"/> Re-check 2 - 4 h.	Sign:
Note:							
..... /	20	<input type="checkbox"/> Rotating knives	<input type="checkbox"/> Fixed counter knives	<input type="checkbox"/> New screws	<input type="checkbox"/> Re-check 2 - 4 h.	Sign:
Note:							
..... /	20	<input type="checkbox"/> Rotating knives	<input type="checkbox"/> Fixed counter knives	<input type="checkbox"/> New screws	<input type="checkbox"/> Re-check 2 - 4 h.	Sign:
Note:							
..... /	20	<input type="checkbox"/> Rotating knives	<input type="checkbox"/> Fixed counter knives	<input type="checkbox"/> New screws	<input type="checkbox"/> Re-check 2 - 4 h.	Sign:
Note:							
..... /	20	<input type="checkbox"/> Rotating knives	<input type="checkbox"/> Fixed counter knives	<input type="checkbox"/> New screws	<input type="checkbox"/> Re-check 2 - 4 h.	Sign:
Note:							
..... /	20	<input type="checkbox"/> Rotating knives	<input type="checkbox"/> Fixed counter knives	<input type="checkbox"/> New screws	<input type="checkbox"/> Re-check 2 - 4 h.	Sign:
Note:							
..... /	20	<input type="checkbox"/> Rotating knives	<input type="checkbox"/> Fixed counter knives	<input type="checkbox"/> New screws	<input type="checkbox"/> Re-check 2 - 4 h.	Sign:
Note:							
..... /	20	<input type="checkbox"/> Rotating knives	<input type="checkbox"/> Fixed counter knives	<input type="checkbox"/> New screws	<input type="checkbox"/> Re-check 2 - 4 h.	Sign:
Note:							
..... /	20	<input type="checkbox"/> Rotating knives	<input type="checkbox"/> Fixed counter knives	<input type="checkbox"/> New screws	<input type="checkbox"/> Re-check 2 - 4 h.	Sign:
Note:							
..... /	20	<input type="checkbox"/> Rotating knives	<input type="checkbox"/> Fixed counter knives	<input type="checkbox"/> New screws	<input type="checkbox"/> Re-check 2 - 4 h.	Sign:
Note:							
..... /	20	<input type="checkbox"/> Rotating knives	<input type="checkbox"/> Fixed counter knives	<input type="checkbox"/> New screws	<input type="checkbox"/> Re-check 2 - 4 h.	Sign:
Note:							

Malfunctions

..... / 20 Fault:
.....
Action: Sign:

..... / 20 Fault:
.....
Action: Sign:

..... / 20 Fault:
.....
Action: Sign:

..... / 20 Fault:
.....
Action: Sign:

..... / 20 Fault:
.....
Action: Sign:

..... / 20 Fault:
.....
Action: Sign:

..... / 20 Fault:
.....
Action: Sign:

..... / 20 Fault:
.....
Action: Sign:

..... / 20 Fault:
.....
Action: Sign:

..... / 20 Fault:
.....
Action: Sign:

..... / 20 Fault:
.....
Action: Sign:

..... / 20 Fault:
.....
Action: Sign:

..... / 20 Fault:
.....
Action: Sign:

..... / 20 Fault:
.....
Action: Sign:

..... / 20 Fault:
.....
Action: Sign:

Notes

..... / 20 Note:
.....
Action: Sign:

..... / 20 Note:
.....
Action: Sign:

..... / 20 Note:
.....
Action: Sign:

..... / 20 Note:
.....
Action: Sign:

..... / 20 Note:
.....
Action: Sign:

..... / 20 Note:
.....
Action: Sign:

..... / 20 Note:
.....
Action: Sign:

..... / 20 Note:
.....
Action: Sign:

..... / 20 Note:
.....
Action: Sign:

..... / 20 Note:
.....
Action: Sign:

..... / 20 Note:
.....
Action: Sign:

..... / 20 Note:
.....
Action: Sign:

..... / 20 Note:
.....
Action: Sign:

..... / 20 Note:
.....
Action: Sign:

..... / 20 Note:
.....
Action: Sign:

..... / 20 Note:
.....
Action: Sign:

..... / 20 Note:
.....
Action: Sign:

