

USER GUIDE  
UGG028-0413

# NCF Series Granulators

NCF-810, NCF-814, NCF-819, NCF-824



We reserve the right to change designs, material and specifications without prior notice..

© Copyright applies to all texts and images in this instruction manual, in full or in part.

Conair Group

This instruction manual belongs to:

---

---

---

---

## Introduction



**Note! All users must study the instruction manual before installing, operating or maintaining the machine.**

This instruction manual contains instructions how to install, operate and maintain the standard versions of the NCF series granulators, Model number NCF-810, NCF-814, NCF-819 and NCF-824.

The performance of your supplied machine may vary from the standard machines described in this instruction manual. In event of any questions, please contact Conair's local distributor or Conair's Corporate office.

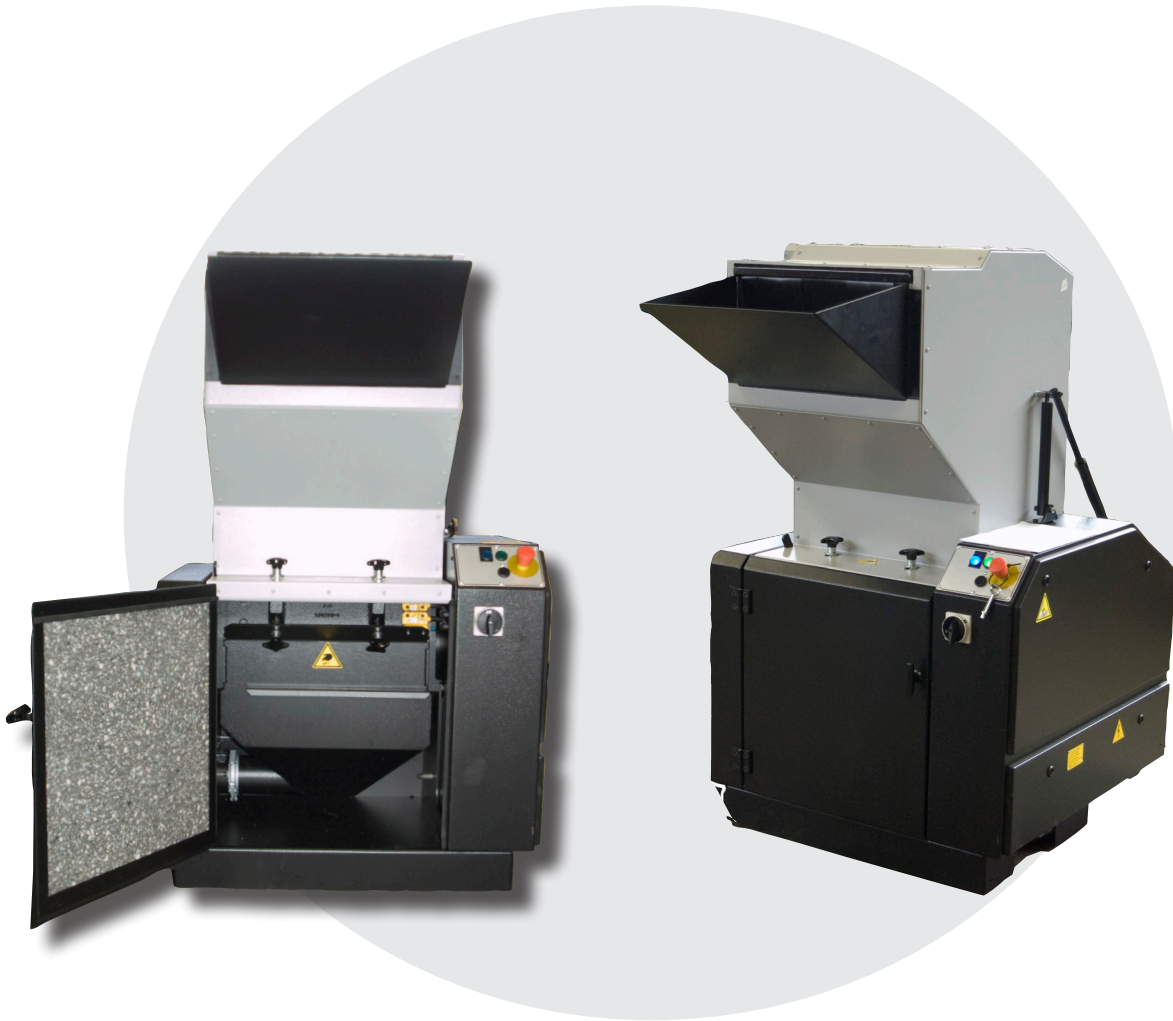

Corporate Office:

The Conair Group  
200 West Kensinger Drive,  
Cranberry Township, PA 16066  
USA

Phone 724.584.5500

US: 800.458.1960

International: 1.814.437.6861

Website: [www.conairgroup.com](http://www.conairgroup.com)

## 1. SAFETY RULES

|   |            |
|---|------------|
| <b>General rules, Safety</b> .....            | <b>1:1</b> |
| Symbols on the machine.....                   | 1:1        |
| Symbols in the instruction manual.....        | 1:1        |
| Risk of machinery damage.....                 | 1:2        |
| Safety rules, During installing.....          | 1:2        |
| Safety rules, During start and operation..... | 1:3        |
| Safety rules, During service.....             | 1:4        |

## 2. DESCRIPTION

|  |                |
|--|----------------|
| <b>Technical specifications</b> .....          | <b>2:1</b>     |
| General data, Supplied machine:.....           | 2:1            |
| General data, NCF series:.....                 | 2:1            |
| Overview.....                                  | 2:2            |
| <b>Layout</b> .....                            | <b>2:3–2:8</b> |
| <b>Function</b> .....                          | <b>2:9</b>     |
| NCF-series.....                                | 2:9            |
| Suffix -810, -814, 819 and -824.....           | 2:10           |
| Sound enclosure option.....                    | 2:10           |
| Blower option.....                             | 2:10           |
| Belt conveyor option.....                      | 2:10           |
| Pipe/profile hopper option.....                | 2:10           |
| Roll feed option.....                          | 2:11           |
| Cyclone option.....                            | 2:11           |
| Dust separator option.....                     | 2:11           |
| <b>Rotor, Rotating knife</b> .....             | <b>2:12</b>    |
| General rules, Rotor and rotating knives.....  | 2:12           |
| 3-blade open rotor.....                        | 2:12           |
| 3-blade staggered rotor.....                   | 2:12           |
| <b>Cutter housing, Fixed knife</b> .....       | <b>2:13</b>    |
| General rules, Cutter housing.....             | 2:13           |
| Cutter housing 1st.....                        | 2:13           |
| Cutter housing 3rd.....                        | 2:13           |
| Fixed knife.....                               | 2:13           |
| <b>Knife clearance</b> .....                   | <b>2:14</b>    |
| Presetting fixture.....                        | 2:14           |
| Grinding fixture.....                          | 2:14           |
| <b>Transmission</b> .....                      | <b>2:15</b>    |
| Motor.....                                     | 2:15           |
| Drive belt(s), Motor pulley, Rotor pulley..... | 2:15           |

## 2. DESCRIPTION

|  |             |
|--|-------------|
| <b>Safety equipment</b> .....            | <b>2:16</b> |
| General rules, Safety equipment.....     | 2:16        |
| Hopper.....                              | 2:17        |
| Inlet.....                               | 2:17        |
| Feed tray.....                           | 2:17        |
| Funnel.....                              | 2:17        |
| Flap(s).....                             | 2:18        |
| Screen, Screen box.....                  | 2:18        |
| Granule bin.....                         | 2:18        |
| Star knob.....                           | 2:19        |
| Safety sensor.....                       | 2:19        |
| Key to the electrical cabinet.....       | 2:20        |
| Electrical cabinet, Operating panel..... | 2:20        |
| Main switch.....                         | 2:20        |
| Emergency stop(s).....                   | 2:20        |
| <b>Overload protection</b> .....         | <b>2:21</b> |
| <b>Level switch</b> .....                | <b>2:22</b> |
| General rules, Level switch.....         | 2:22        |
| Level switch, Paddle type.....           | 2:22        |
| Hour counter.....                        | 2:22        |
| <b>Current relay</b> .....               | <b>2:23</b> |
| General rules, Current relay.....        | 2:23        |
| Limit value “LVA”.....                   | 2:23        |
| Hysteresis “HA”.....                     | 2:23        |
| Reaction time “T1”.....                  | 2:24        |
| Time delay during start up “T2”.....     | 2:24        |
| Yellow LED.....                          | 2:24        |
| Green LED.....                           | 2:24        |
| Function setting.....                    | 2:25        |

### 3. TRANSPORT / LIFT

|   |            |
|---|------------|
| <b>General rules, Transport / Lift.....</b> | <b>3:1</b> |
| Transport.....                              | 3:1        |
| Lift the granulator.....                    | 3:1        |

### 4. INSTALLING

|   |            |
|---|------------|
| <b>Actions before first start.....</b>          | <b>4:1</b> |
| General rules, Installing.....                  | 4:1        |
| Reception inspection.....                       | 4:1        |
| Put the machine in its working place.....       | 4:1        |
| Remove the rust preventer.....                  | 4:2        |
| Check the knife clearance.....                  | 4:2        |
| Technical specifications.....                   | 4:2        |
| <b>Electrical connection.....</b>               | <b>4:3</b> |
| General rules, Electrical connection.....       | 4:3        |
| Emergency stop(s).....                          | 4:3        |
| Connect the granulator to the mains.....        | 4:3        |
| <b>Start the granulator.....</b>                | <b>4:4</b> |
| <b>Check immediately after first start.....</b> | <b>4:4</b> |
| <b>Checks 30 hours after first start.....</b>   | <b>4:5</b> |

### 5. START / STOP

|                                  |            |
|----------------------------------|------------|
| <b>Start the granulator.....</b> | <b>5:1</b> |
| <b>Stop the granulator.....</b>  | <b>5:1</b> |

### 6. OPEN / CLOSE

|   |            |
|---|------------|
| <b>General rules, Open the granulator.....</b>  | <b>6:1</b> |
| Open the enclosure.....                         | 6:1        |
| Open the transmission.....                      | 6:1        |
| Open the tranule bin.....                       | 6:2        |
| Open the screen box.....                        | 6:2        |
| Open the hopper.....                            | 6:3        |
| <b>General rules, Close the granulator.....</b> | <b>6:4</b> |
| Close the hopper.....                           | 6:4        |
| Close the screen box.....                       | 6:5        |
| Close the granule bin.....                      | 6:5        |
| Close the enclosure.....                        | 6:6        |
| Close the transmission.....                     | 6:6        |

### 7. SERVICE

|                                       |             |
|---------------------------------------|-------------|
| <b>General rules, Service.....</b>    | <b>7:1</b>  |
| Service schedule.....                 | 7:1         |
| Emergency stop(s).....                | 7:1         |
| Flap(s).....                          | 7:1         |
| Safety equipment.....                 | 7:2         |
| Electrical components.....            | 7:2         |
| Level switch.....                     | 7:3         |
| Current relay.....                    | 7:4         |
| Band conveyor.....                    | 7:5         |
| Important tightening torques.....     | 7:6         |
| Lubrication.....                      | 7:6         |
| Storage.....                          | 7:6         |
| <b>Cleaning.....</b>                  | <b>7:7</b>  |
| <b>Knives.....</b>                    | <b>7:8</b>  |
| General rules, Knives.....            | 7:8         |
| Remove the rotating knives.....       | 7:9         |
| Granulator with open rotor.....       | 7:9         |
| Granulator with staggered rotor.....  | 7:9         |
| Install the rotating knife.....       | 7:10        |
| Granulator with open rotor.....       | 7:10        |
| Granulator with staggered rotor.....  | 7:10        |
| Remove the fixed knife 2nd.....       | 7:11        |
| Install the fixed knife 2nd.....      | 7:11        |
| Remove the fixed knife 5nd.....       | 7:12        |
| Install the fixed knife 5th.....      | 7:12        |
| General rules, Fixed knife 3rd.....   | 7:13        |
| Remove the fixed knife 3rd.....       | 7:13        |
| Install the fixed knife 3rd.....      | 7:13        |
| Knife clearance.....                  | 7:14        |
| General rules, Grind the knives.....  | 7:15        |
| General rules, Preset the knives..... | 7:17        |
| <b>Drive belt(s).....</b>             | <b>7:18</b> |
| General rules, Drive belt(s).....     | 7:18        |
| Check the drive belt(s).....          | 7:18        |
| Adjust the belt tension.....          | 7:19        |
| <b>Fault tracing.....</b>             | <b>7:20</b> |

## 8. SERVICE REPORT

Service actions ..... 8:1

## 9. SPARE PARTS

General rules, Spare parts..... 9:1

- Flap(s) ..... 9:2-9:3
- Funnel, Feed tray, Inlet ..... 9:4-9:5
- Hopper ..... 9:6-9:7
- Hopper device ..... 9:8-9:9
- Safety ..... 9:10
- Cutter housing ..... 9:11-9:14
- Staggered rotor ..... 9:15
- Open rotor ..... 9:16
- Knives for a staggered rotor ..... 9:17
- Knives for an open rotor ..... 9:18
- Screen ..... 9:19
- Screen box ..... 9:20
- Granule bin, Outlet pipe ..... 9:21
- Blower ..... 9:22
- Transmission ..... 9:23
- Enclosure, Transmission ..... 9:24
- Enclosure ..... 9:25
- Body ..... 9:26
- Options ..... 9:27

## General rules, Safety

Conair NCF Series granulators, shredders, guillotines and accessory equipment for processing injection moulded, blow moulded or extruded plastics. The machines are designed and adapted to the type of plastic residue that the customer has specified before order.

The machines are manufactured in accordance to the state of the art and legal safety regulations (guidelines, harmonized standards), which demand a very low safety risk. But, if the machines are incorrectly operated, unexpected dangers can arise. Therefore it is very important that all instructions are carefully observed and attended to. All users must study the instruction manual before installing, operating or maintaining the machine. In event of any questions, please contact Conair's local distributor or Conair's head office.



**Danger! It is not permissible to feed the machine with explosive material or material contaminated with explosive or easily ignited substances. It is not permissible to feed the machine with wood products, household or garden waste, pharmaceutical products or substances which present a health danger, unless a written approval has been obtained from Conair's head office. If any materials are processed that are not contractually agreed upon, Conair is absolved of any liability and guarantee for safety and functioning of the machine.**



**Danger! No modifications or alterations to Conair's products are permissible unless a written approval has been obtained from Conair's head office. This is to prevent injury, to maintain the machinery warranty valid, and to guarantee that Conair can fully assume their product liability. If any modifications are done, Conair is absolved of any liability and guarantee for safety and functioning of the machine.**

## Symbols on the machine



Danger! Risk of cutting or pinch injuries! This symbol is placed anywhere there is a risk of cutting or pinch injuries.



Danger! Dangerous voltage! This symbol is placed on electrical cabinet hatches and on any junction boxes.



Request! All users must study the instruction manual before installing, operating or maintaining the machine.

## Symbols in the instruction manual



Danger! Personal injury! This symbol is used to indicate risk of personal injury. The symbol inside the triangle may have different appearances, depending on the type of danger.



Danger! Machinery damage! This symbol is used to indicate risk of machinery damage.



Information! This symbol is used to highlight useful information.

## Risk of machinery damage



- If incorrect material is fed into the machine.
- If the belt tension is incorrect or if the drive belt(s) is/are worn.
- If the bearing housing are not cleaned on a regular basis.
- If the screen in the screen box is worn or incorrectly installed.
- If the knives' tightening screws are tightened with incorrect tightening torque.
- If the knife clearance is wrong.
- If the knives are blunt.
- If the instructions in the instruction manual are not followed accurately.

## Safety rules, During installing



- The machine must be installed by authorized, trained personnel.
- The machine must be disconnected from the mains before electrical repairs or electrical installing is begun.
- The instruction manual must be carefully observed to avoid personal injury and machinery damage.
- The machine must be installed and connected to other equipment so that the entire installation complies with the stipulations of the Machinery Directive 2006/42/EC.

## Safety rules, During start and operation



- The instruction manual must be carefully observed to avoid personal injury and machinery damage.
- National environmental and employee safety regulations must be followed.
- The machine must be installed in accordance with this instruction manual.
- All covers must be installed. All hatches to electrical cabinet, transmission and pneumatics (if supplied) must be closed and locked. The key must be kept by the personnel responsible for the machine's service and safety.
- The screen must be installed.
- The screen box must be closed.
- The granule bin must be closed.
- The cutter housing must be closed.
- The hopper must be closed.
- Granulator with inlet: The inlet must be installed.
- Granulator with feed tray: The feed tray must be installed.
- Granulator with funnel: The funnel must be installed.
- Granulator with wheels: The wheels must be locked.
- All safety switches and magnet switches must be installed.
- All star knobs must be screwed in until they stop moving.
- All outer safety equipment such as protective screens, bars, covers, plates, nets etc must be installed.



- Be very careful. The machine contains knives. Risk of cutting or pinch injuries!
- Never place any part of your body into any opening. Risk of cutting or pinch injuries!
- Use ear defenders. Risk of loud, damaging noise!
- Use protective goggles. Risk of granulate splashing!
- Do not tread on the machine.



- A granulator with optional sound enclosure:
  - The enclosure must be closed.



- A granulator with optional blower:
  - Be very careful. The blower has a very powerful suction and blowing ability. Never place any parts of your body into or near any blower openings.
  - Blowers must not be used in ambient temperatures above +104°F {+40°C}, in ambient temperatures below -4°F {-20°C}, in explosion hazard atmospheres or unprotected outdoors.
  - The temperature of the transported material must never increase +176°F {+80°C}.

## Safety rules, During service



- A granulator with optional belt conveyor:
  - Be very careful. Clothing and parts of your body can be dragged along the conveyor belt.
  - Do not tread on the belt conveyor.
  - If hot material is to be transported on the belt, this must be placed in the middle of the belt. Uneven heating of the belt can make the belt pull to one side.



- The instruction manual must be carefully observed to avoid personal injury and machinery damage.
- National environmental and employee safety regulations must be followed.
- First aid and eye shower must be within reach.
- Daily service and daily checks may be done by the operator. All other service and inspections must be done by authorized, trained personnel.
- Always work alone when service actions is performed.
- Use protective goggles and gloves.
- The machine must be stopped.
- The machine's main switch must be locked in position "0". Never insert any part of your body into any opening, unless the main switch is locked in position "0".
- The machine must be disconnected from the mains before electrical repairs or electrical installing is begun.



- Be very careful – When opening and closing the machine. Risk of cutting or pinch injuries.
- Be very careful – When checking and changing drive belt(s). Risk of cutting or pinch injuries!
- Be very careful – When the machine is opened the knives are accessible. The knives are sharp, and they may cause personal injuries even when they are not rotating. The rotor can rotate by itself. Always lock the rotor with a piece of wood to prevent the rotor from self-rotating. Risk of cutting or pinch injuries!
- Be very careful – When pulling the rotor or the rotor pulley manually. Risk of cutting or pinch injuries!
- Be very careful – When cleaning. Granulate and plastic residue can make the floor slippery.
- Be very careful – When working on high level. Only use specially installed and fastened steps, stairs and platforms. It is not permissible to remove any outer safety equipment such as protective screens, bars, nets etc.
- After service / check is done all covers must be reinstalled. All hatches to electrical cabinet, transmission and pneumatics (if supplied) must be closed and locked. The key must be kept by the personnel responsible for the machine's service and safety.



- A granulator with optional belt conveyor:
  - The belt conveyor's main switch must be locked in position "0".
  - The belt conveyor's mains plug must be disconnected from the mains.

## Technical specifications

### General data, Supplied machine:

Fill in correct information, so that the data corresponds with the machine sign on your supplied machine:

Machine type: .....

Serial number:..... Manufacturing year: .....

Motor: ..... V ..... Hz ..... kW Electrical circuit diagram: .....

### General data, Conair NCF Series Granulators:

Mark the correct alternatives, so that the data corresponds with your supplied machine:

Model number: .....  NCF-810  NCF-814  NCF-819  NCF-824

Rotor (Ø x Width):  7.9x9.4 in {200x240 mm}  7.9x14.2 in {200x360 mm}  7.9x18.9 in {200x480 mm}  7.9x23.6 in {200x600mm}

Cutter housing: .....  1st  3rd  5th

Rotor: .....  3-blade open rotor  3-blade staggered rotor

Rotating knives: .....  1x3 (1 pcs/blade) = 3-blade open rotor, NCF-810, NCF-814, NCF-819, NCF-824

.....  2x3 (2 pcs/blade) = 3-blade staggered rotor, NCF-810

.....  3x3 (3 pcs/blade) = 3-blade staggered rotor, NCF-814

.....  4x3 (4 pcs/blade) = 3-blade staggered rotor, NCF-819

.....  5x3 (5 pcs/blade) = 3-blade staggered rotor, NCF-824

Fixed knives: .....  1x2 (1 pcs/knife seat) = Cutter housing 1st, NCF-810, NCF-814, NCF-819

.....  2x2 (2 pcs/knife seat) = Cutter housing 1st, NCF-824

.....  1x3 (1 pcs/knife seat) = Cutter housing 3rd, NCF-810, NCF-814, NCF-819

.....  2x3 (2 pcs/knife seat) = Cutter housing 3rd, NCF-824

.....  1x3 (1 pcs/knife seat) = Cutter housing 5th, NCF-810, NCF-814, NCF-819

.....  2x3 (2 pcs/knife seat) = Cutter housing 5th, NCF-824

Screen, Ø:  .16in {4 mm}  .20in {5 mm}  .31in {8 mm}  .39in {10 mm}  .47in {12 mm}  .67in {17 mm}  .98in {25 mm}

Capacity: .....  1,102.3-5,511.6 lb/h {500-2500 kg/h}

Motor power: .....  4.0 kW  5.5 kW  7.5 kW  11.0 kW

Rotor speed: .....  260 rpm (4.0 kW, 5.5 kW)  406 rpm (7.5 kW, 11.0 kW)

Drive belt(s): .....  3 pcs (4.0 kW, 5.5 kW, 7.5 kW)  4 pcs (11.0 kW)

Weight\*:  926 lb {420 kg} (NCF-810-K)  1014 lb {460 kg} (NCF-814)  1157.4 lb {525kg} (NCF-819)  1256.6 lb {570 kg} (NCF-824)

\*The weight varies dependent on; hopper size, type of cutter housing, type of rotor, motor size, enclosures etc.

Sound level, Idle operation\*\*: .....  70-80 dBA (-K)

\*\* (The specified sound level is dependent on granulator size, capacity, temperature etc).

Options: .....  Grinding fixture  Presetting fixture

.....  Level switch, Paddle type  Hours counter

Current relay Current transformer: ..... (1/A)  LVA, Y/D-start: Rated current ..... A /  $\sqrt{3}$  = ..... A

LV%: ..... H%: .....  LVA, Direct-start: Rated current ..... A / 1 = ..... A

Material transport: .....  Blower F7 (0.55 kW)  Blower F15 (0.90 kW)

.....  Band conveyor  Metal detector "Tunnel"  Metal detector "Area"

.....  Cyclone AX 7.5

### Overview

The performance of your supplied machine may vary from the standard machines described in this instruction manual. In event of any questions, please contact Conair's local distributor or Conair's head office.

- Funnel ..... (1)
- Hopper ..... (2)
- Hopper device ..... (3)
- Safety sensor, Hopper ..... (4)
- Star knob, Hopper ..... (5)
- Tipping catch ..... (6)
- Cutter housing ..... (7)
- Rotor, Rotating knife ..... (8)
- Quick coupling ring, Granule bin ..... (9)
- Granule bin ..... (10)
- Screen ..... (11)
- Screen box ..... (12)
- Star knob, Screen box ..... (13)
- Safety sensor, Screen box ..... (14)
- Main switch ..... (15)
- Emergency stop ..... (16)
- Stop-button ..... (17)
- Start-button ..... (18)
- Knob "Hopper, Close / Open" ..... (19)
- Button "Operate 1" ..... (20)
- Button "Operate 2" ..... (21)
- Operating panel, Heavy hopper ..... (22)
- Operating panel, Light hopper ..... (23)
- Electrical cabinet ..... (24)
- Cover, Electrical cabinet ..... (25)
- Cover, Transmission ..... (26)
- Rear cover ..... (27)
- Rotor pulley ..... (28)
- Drive belt(s) ..... (29)
- Motor pulley ..... (30)
- Motor ..... (31)
- Tightening screws, Motor ..... (32)
- Adjusting screws, Belt tension ..... (33)
- Button "Reset safety relays" ..... (34)

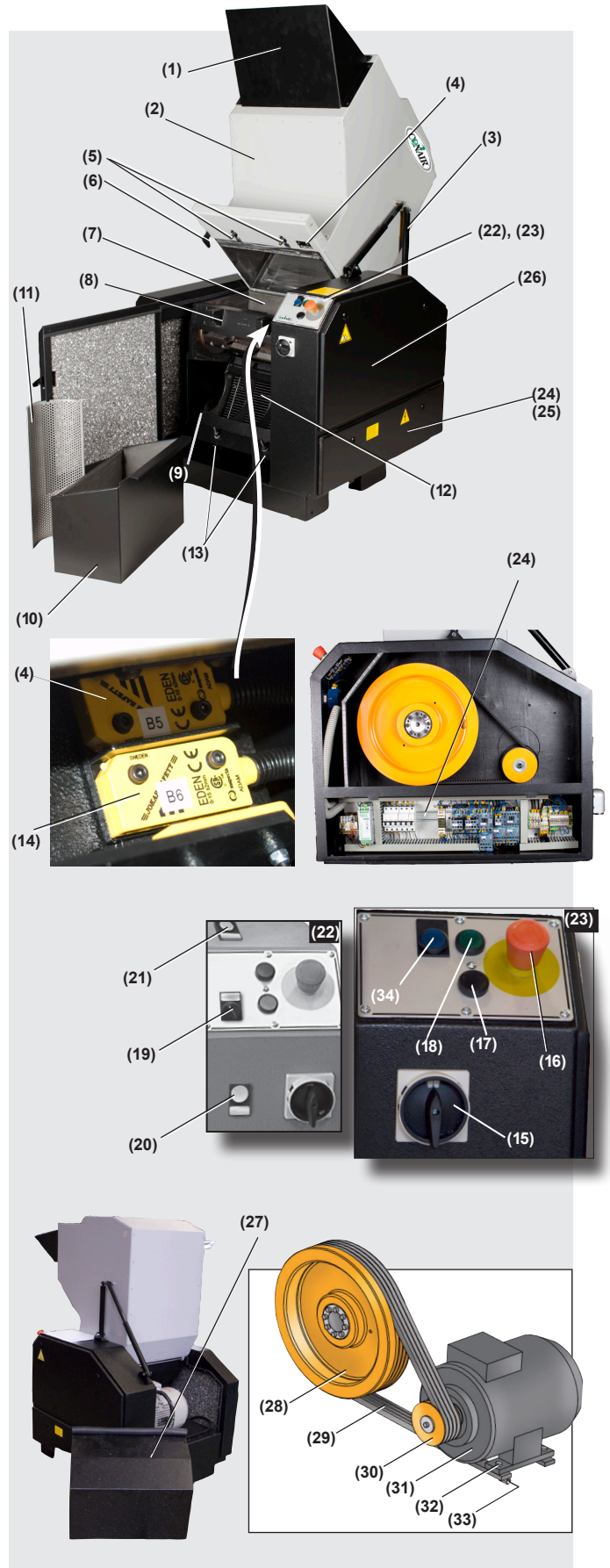

DESCRIPTION

# Layout

NCF  
HOPPER FRONT,  
FUNNEL

LAYOUT NO: 4-68000-1-C01

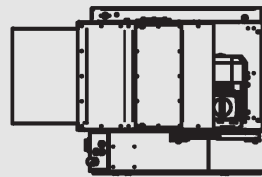
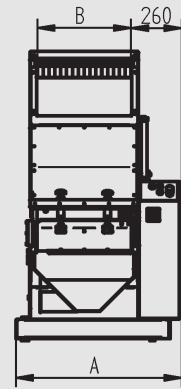
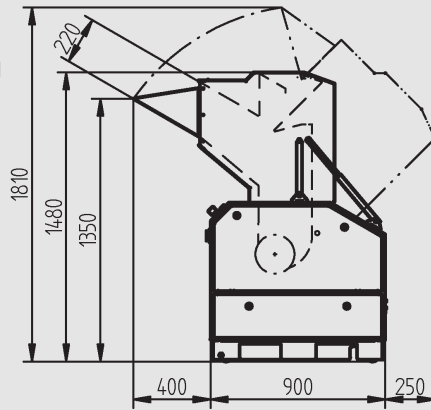

| NCF | -810 | -814 | -819 | -824 |
|-----|------|------|------|------|
| A   | 610  | 730  | 850  | 970  |
| B   | 240  | 350  | 480  | 600  |

NCF- OPTIONAL SOUND ENCLOSURE  
HOPPER FRONT,  
FUNNEL

LAYOUT NO: 4-68001-1-C01

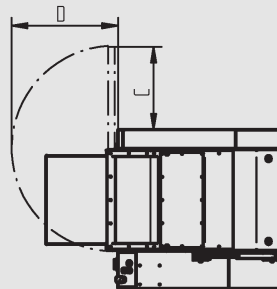
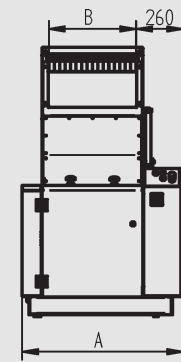
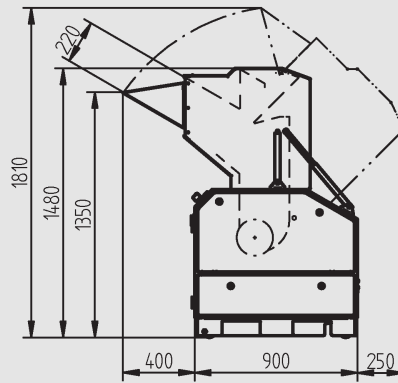

| NCF | -810 | -814 | -819 | -824 |
|-----|------|------|------|------|
| A   | 650  | 770  | 890  | 1100 |
| B   | 240  | 360  | 480  | 600  |
| C   | 210  | 330  | 450  | 570  |
| D   | 330  | 450  | 570  | 690  |

DESCRIPTION

### Layout

NCF  
HOPPER FRONT,  
FEED TABLE

LAYOUT NO: 4-68008-1-C01

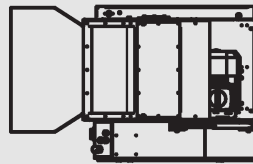
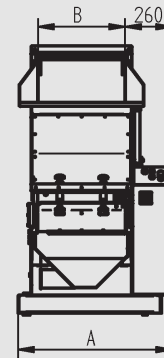
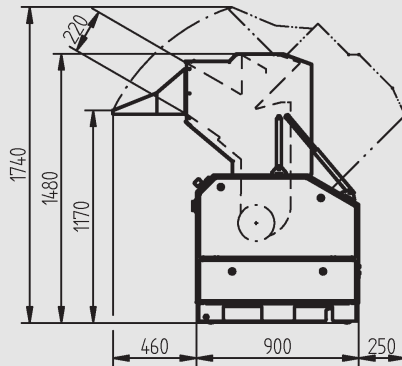

| NCF | -810 | -814 | -819 | -824 |
|-----|------|------|------|------|
| A   | 610  | 730  | 850  | 970  |
| B   | 240  | 360  | 480  | 600  |

NCF-OPTIONAL SOUND ENCLOSURE / BLOWER  
HOPPER FRONT,  
FEED TABLE  
BLOWER F7,  
CYCLONE AX7.5,

LAYOUT NO: 4-68009-1-C01

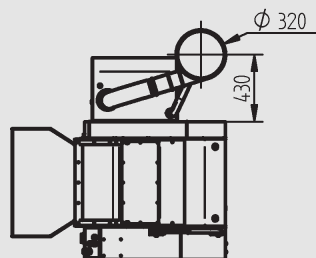
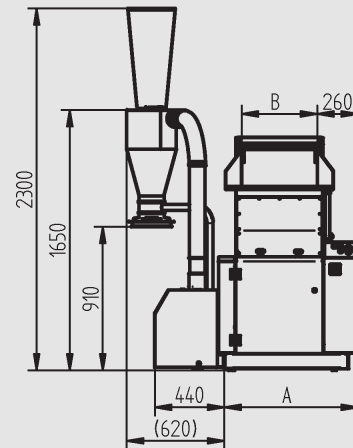
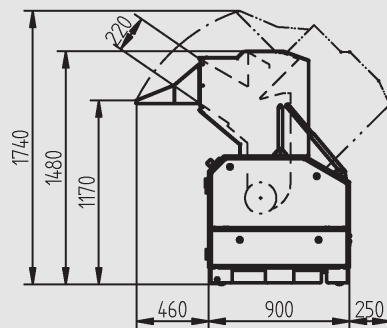

| NCF | -810 | -814 | -819 | -824 |
|-----|------|------|------|------|
| A   | 610  | 730  | 850  | 970  |
| B   | 240  | 360  | 480  | 600  |

DESCRIPTION

### Layout

**NCF-OPTIONAL SOUND ENCLOSURE / BLOWER**  
**HOPPER FRONT,**  
**FUNNEL,**  
**BLOWER F7,**  
**CYCLONE AX7.5,**  
**BAG HOLDER**

LAYOUT NO:  
 4-68002-1-C01

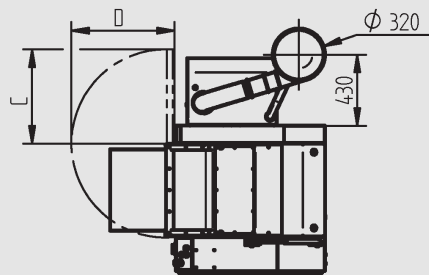
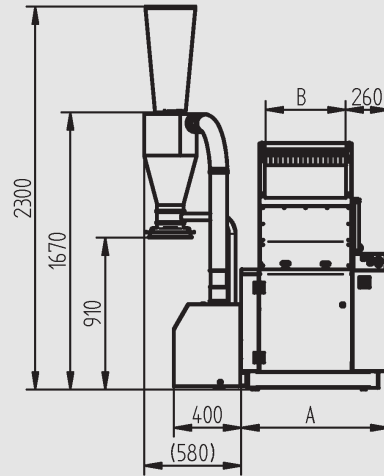
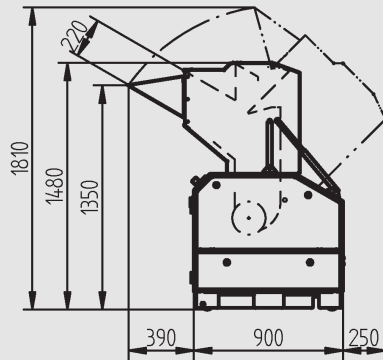

| NCF | -810 | -814 | -819 | -824 |
|-----|------|------|------|------|
| A   | 650  | 770  | 890  | 1100 |
| B   | 240  | 360  | 480  | 600  |
| C   | 210  | 330  | 450  | 570  |
| D   | 330  | 450  | 570  | 690  |

**NCF-SERIES**  
**HOPPER FRONT,**  
**FUNNEL**  
**BLOWER F15,**  
**CYCLONE AX12,**  
**BAG HOLDER**

LAYOUT NO:  
 4-68006-1-C01

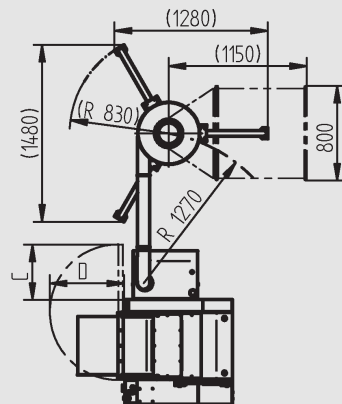
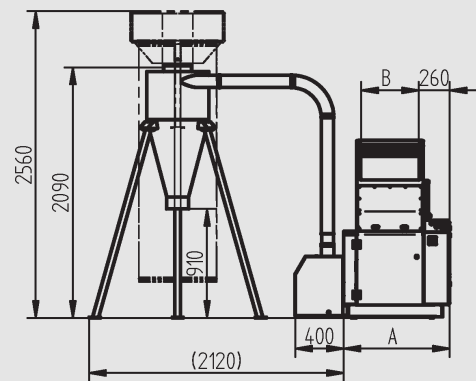
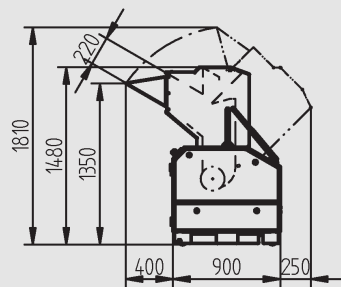

| NCF | -810 | -814 | -819 | -824 |
|-----|------|------|------|------|
| A   | 650  | 770  | 890  | 1100 |
| B   | 240  | 360  | 480  | 600  |
| C   | 210  | 330  | 450  | 570  |
| D   | 330  | 450  | 570  | 590  |

DESCRIPTION

Layout

NCF-OPTIONAL SOUND ENCLOSURE  
 OPTIONAL BLOWER  
 OPTIONAL BELT CONVEYOR  
 HOPPER FRONT,  
 BELT CONVEYOR,  
 BLOWER F7,  
 CYCLONE AX7.5,  
 BAG HOLDER

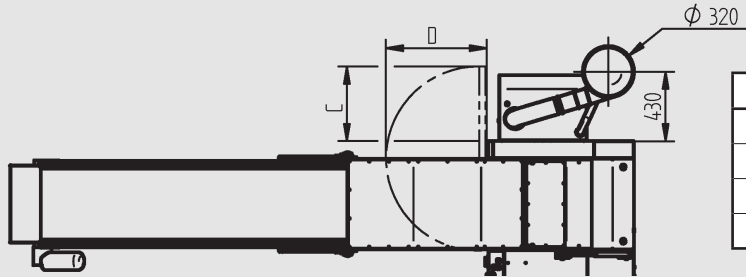
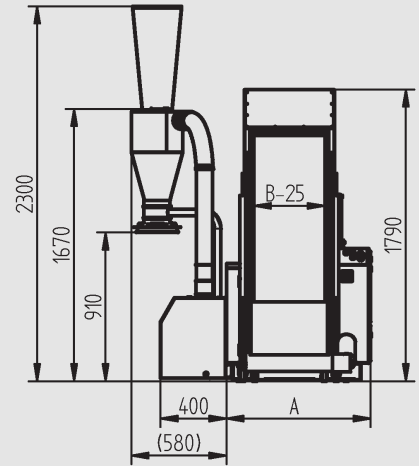
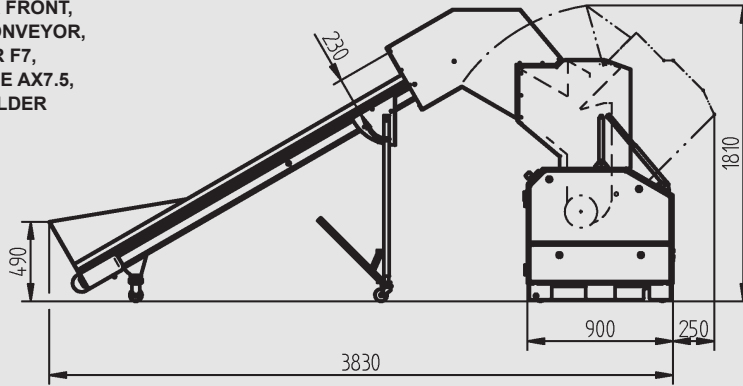

| NCF | -810 | -814 | -819 | -824 |
|-----|------|------|------|------|
| A   | 650  | 770  | 890  | 1100 |
| B   | 240  | 360  | 480  | 600  |
| C   | 210  | 330  | 450  | 570  |
| D   | 330  | 450  | 570  | 690  |

NCF-OPTIONAL SOUND ENCLOSURE  
 OPTIONAL BLOWER  
 OPTIONAL BELT CONVEYOR  
 HOPPER FRONT,  
 BELT CONVEYOR,  
 BLOWER F15,  
 CYCLONE AX12

LAYOUT NO:  
 4-68007-1-C01

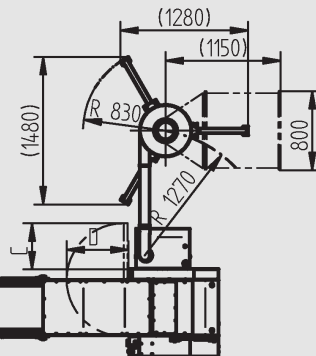
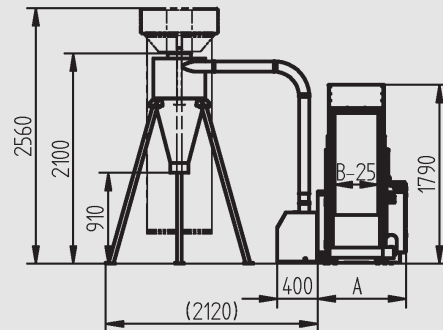
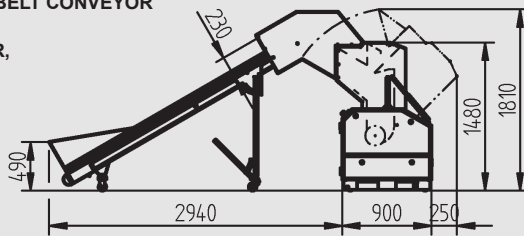

| NCF | -810 | -814 | -819 | -824 |
|-----|------|------|------|------|
| A   | 650  | 770  | 890  | 1100 |
| B   | 240  | 360  | 480  | 600  |
| C   | 210  | 330  | 450  | 570  |
| D   | 330  | 450  | 570  | 690  |

DESCRIPTION

Layout

NCF  
HOPPER FRONT,  
H180

LAYOUT NO: 4-68010-1-C01

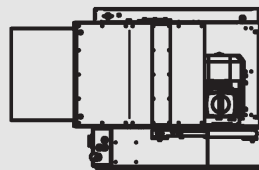
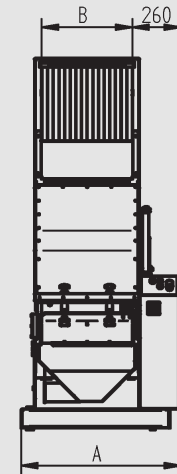
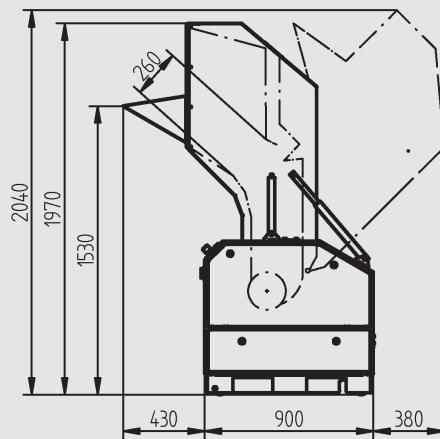

| NCF | -810 | -814 | -819 | -824 |
|-----|------|------|------|------|
| A   | 610  | 730  | 850  | 970  |
| B   | 240  | 360  | 480  | 600  |

NCF-OPTIONAL SOUND ENCLOSURE  
OPTIONAL BLOWER  
OPTIONAL BELT CONVEYOR

HOPPER FRONT,  
H180  
BLOWER F7  
CYCLONE AX7.5

LAYOUT NO: 4-68011-1-C01

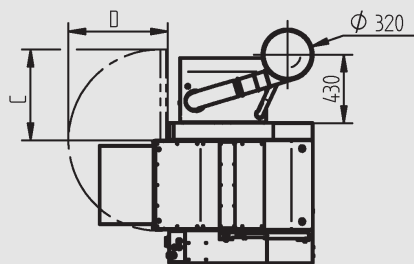
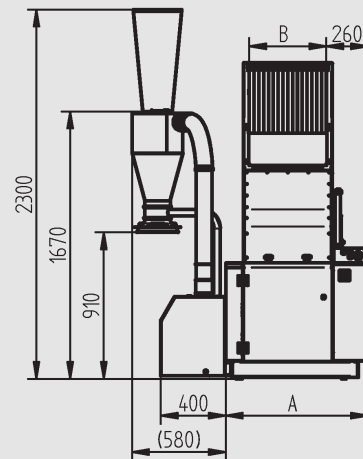
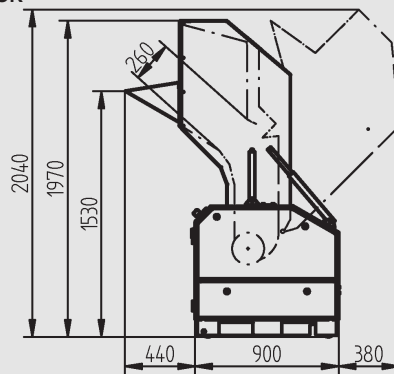

| NCF | -810 | -814 | -819 | -824 |
|-----|------|------|------|------|
| A   | 650  | 770  | 890  | 1100 |
| B   | 240  | 360  | 480  | 600  |
| C   | 210  | 330  | 450  | 570  |
| D   | 330  | 450  | 570  | 690  |

DESCRIPTION

## 2. DESCRIPTION



GX036-0413

## SPECIFICATIONS

DESCRIPTION

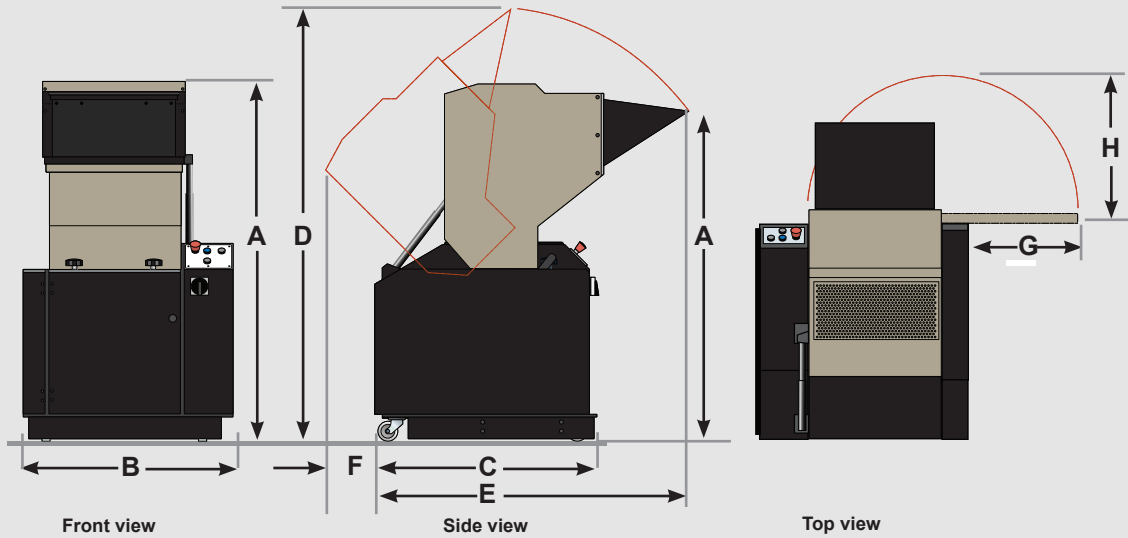

| MODELS                                       | NCF-810   | NCF-814                     | NCF-819                     | NCF-824                     |
|--|---|-----------------------------|-----------------------------|-----------------------------|
| <b>Performance characteristics</b>           |   |                             |                             |                             |
| Rotor diameter inches {cm}                   | 8.0 {20.3}  |                             |                             |                             |
| Cutterhouse configuration                    | super-tangential/ tangential 3-blade with 3rd bed knife/ tangential 3-blade |                             |                             |                             |
| Rotor type                                   | staggered (standard), open (optional)                                       |                             |                             |                             |
| Rotor speed rpm                              | 260 (optional 400, 840)   |                             |                             |                             |
| <b>Rotating knives</b>                       |   |                             |                             |                             |
| Staggered configuration                      | 3 x 2   | 3 x 3                       | 3 x 4                       | 3 x 5                       |
| Open configuration                           | 3 x 2   | 3 x 2                       | 3 x 2                       | 3 x 2                       |
| <b>Hopper inlet inches {cm}</b>              |   |                             |                             |                             |
|  | 9.5 x 8.0<br>{24.1 x 20.3}  | 14.0 x 8.0<br>{35.6 x 20.3} | 19.0 x 8.0<br>{48.3 x 20.3} | 24.0 x 8.0<br>{61.0 x 20.3} |
| <b>Motor standard Hp {kW}*</b>               |   |                             |                             |                             |
|  | 5 {3.7}   | 7.5 {5.6}                   | 7.5 {5.6}                   | 7.5 {5.6}                   |
| <b>Maximum throughput capacity† lbs {kg}</b> |   |                             |                             |                             |
|  | 165 {75}  | 220 {100}                   | 325 {147}                   | 450 {204}                   |
| <b>Dimensions inches {cm}</b>                |   |                             |                             |                             |
| A - Height                                   | 58.00 {147.32}  | 58.00 {147.32}              | 58.00 {147.32}              | 58.00 {147.32}              |
| B - Width                                    | 26.00 {66.04}   | 30.00 {76.20}               | 35.00 {88.90}               | 43.00 {109.22}              |
| C - Depth                                    | 35.50 {90.17}   | 35.50 {90.17}               | 35.50 {90.17}               | 35.50 {90.17}               |
| D - Clearance height                         | 68.50 {173.99}  | 68.50 {173.99}              | 68.50 {173.99}              | 68.50 {173.99}              |
| E - Overall depth                            | 53.50 {135.89}  | 53.50 {135.89}              | 53.50 {135.89}              | 53.50 {135.89}              |
| F - Rear clearance                           | 10.00 {25.40}   | 10.00 {25.40}               | 10.00 {25.40}               | 10.00 {25.40}               |
| G - Side clearance (door swing)              | 8.25 {20.96}  | 13.00 {33.02}               | 17.75 {45.09}               | 22.50 {57.15}               |
| H - Front clearance (door swing)             | 13.00 {33.02}   | 17.75 {45.09}               | 22.50 {57.15}               | 27.00 {68.58}               |
| <b>Weight‡ lb {kg}</b>                       |   |                             |                             |                             |
| Installed                                    | 1100 {499}  | 1200 {544}                  | 1400 {635}                  | 1650 {748}                  |
| Shipping                                     | 1300 {590}  | 1400 {635}                  | 1650 {748}                  | 1900 {862}                  |

### CUTTER HOUSING CONFIGURATIONS

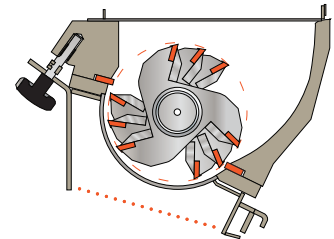

Super-tangential with staggered rotor

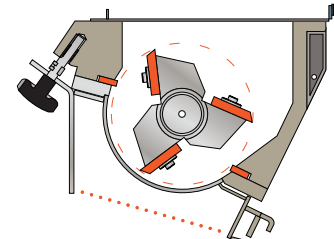

Tangential with open 3-blade rotor

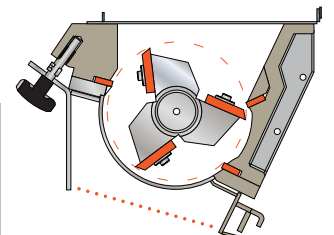

Tangential with open 3-blade rotor/3rd bed knife

### SPECIFICATION NOTES:

\* Optional available motors are 5 Hp {3.7 kW}, 7.5 Hp {5.6 kW}, 10 Hp {7.5 kW}, and 15 Hp {11.2 kW}.

† Throughputs are provided as a capacity guideline only. Throughput will be greater or lesser than the values shown according to the selected screen size and the shape, size, thickness and properties of the material to be cut.

‡ Weight is estimated and will vary based on configuration.

Consult Conair for a material test to help in determining the correct granulator model for your application.

Specifications may change without notice, consult with a Conair representative for the most current information.

## Function

### Conair NCF Series Granulators

Conair NCF Series granulators are designed for granulating injection moulded, blow moulded or extruded plastic residue. The function of the granulator can be described as follows:

1. The plastic residue, which must be free from metal and contamination, is fed into the granulator's hopper. The hopper can be provided with a funnel, a feed tray or a KB-inlet.
2. The plastic residue falls through the hopper and down into the cutter housing. The cutter housing contains fixed knives and a rotor.
3. Rotating knives are mounted on the rotor. The plastic residue is granulated (cut up) between the rotating knives on the rotor and the fixed knives in the cutter housing.
4. The size of the granulate (the cut up plastic residue) is determined by the screen. The screen is installed in the screen box in the base of the cutter housing. The screen can easily be changed to give the required granulate size.
5. The granulate passes through the screen down into the granule bin, which collects the finished granulate.
6. The granule bin can be emptied manually or by means of a blower.

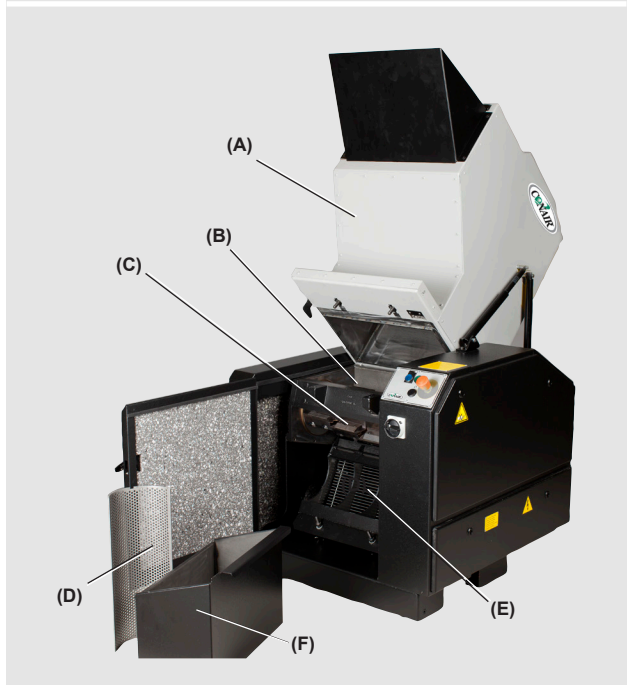
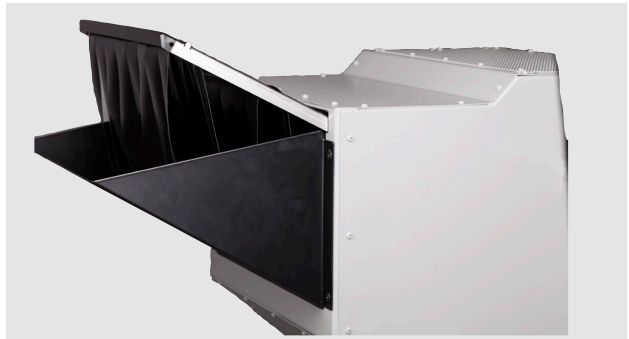

- (A) = Hopper
- (B) = Cutter housing
- (C) = Rotating knives, Rotor
- (D) = Screen
- (E) = Screen box
- (F) = Granule bin

## Function

### Suffix -810, -814, -819 and -824

The additional suffix -810, -814, -819 and -824 refers to the cutter housing's width.

### Sound Enclosure Option

Your granulator may be equipped with an optional sound insulating enclosure. >Page 9:23–9:24 “Enclosure”.

### Blower Option

The blower transports granulate on from the granule bin to units such as a dust separation system or a granulate container for later use. Blowers are available with or without sound insulating enclosure. Optional blowers; F7. >Page 9:21 “Blower”.

### Belt Conveyor Option

The belt conveyor transports plastic residue to the granulator's inlet / hopper. The belt conveyor can be provided with a metal detector.

### Pipe/Profile Hopper Option

Your granulator may be provided with a hopper that is adapted to granulation for pipes and profiles. >Page 9:5–9:6 “Hopper”.

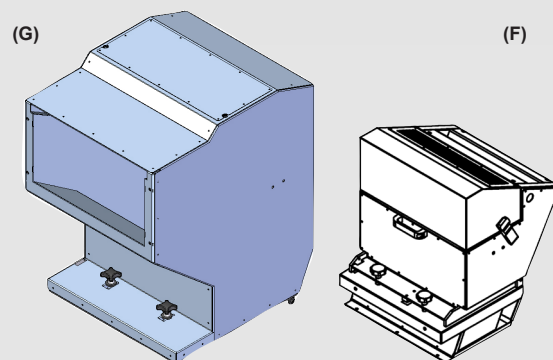
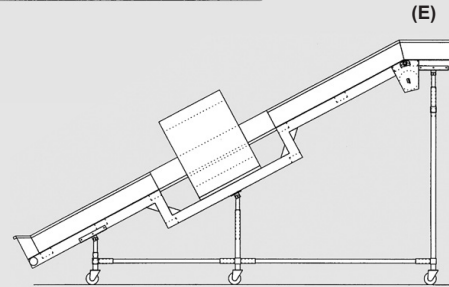
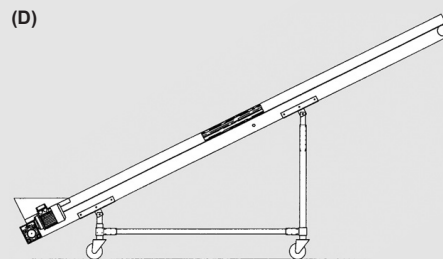
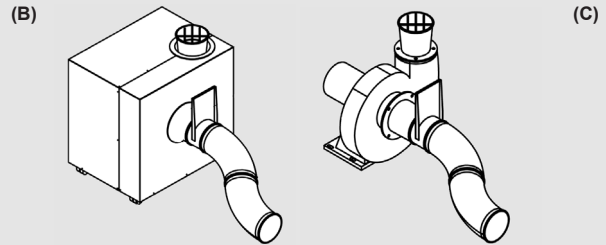
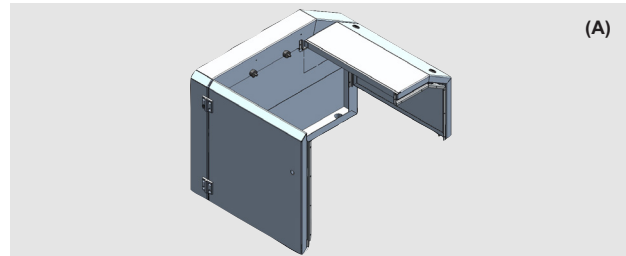

- (A) = Enclosure
- (B) = Blower, With enclosure
- (C) = Blower, Without enclosure
- (D) = Belt conveyor, With area detector (MDA)
- (E) = Belt conveyor, With tunnel detector (MDTD)
- (F) = Hopper, Adapted for pipes
- (G) = Hopper, Enclosed

## Function

### Roll Feed Option

The roller feeder contains rotating rollers which feed the plastic foil into the granulator's cutter housing. Optional roller feeders; RFL, RFS.

>Please refer to separate instruction manual "Roller feeder".

### Cyclone Option

The cyclone separates air from finished granulate. The cyclone's air outlet can be provided with a filter. Optional cyclones; AX7.5.

### Dust Separator Option

The dust separator system cleans the finished granulate. Optional dust separator systems; DS-50 or DS-400.

>Please refer to separate instruction manual "DS-50" or DS-400".

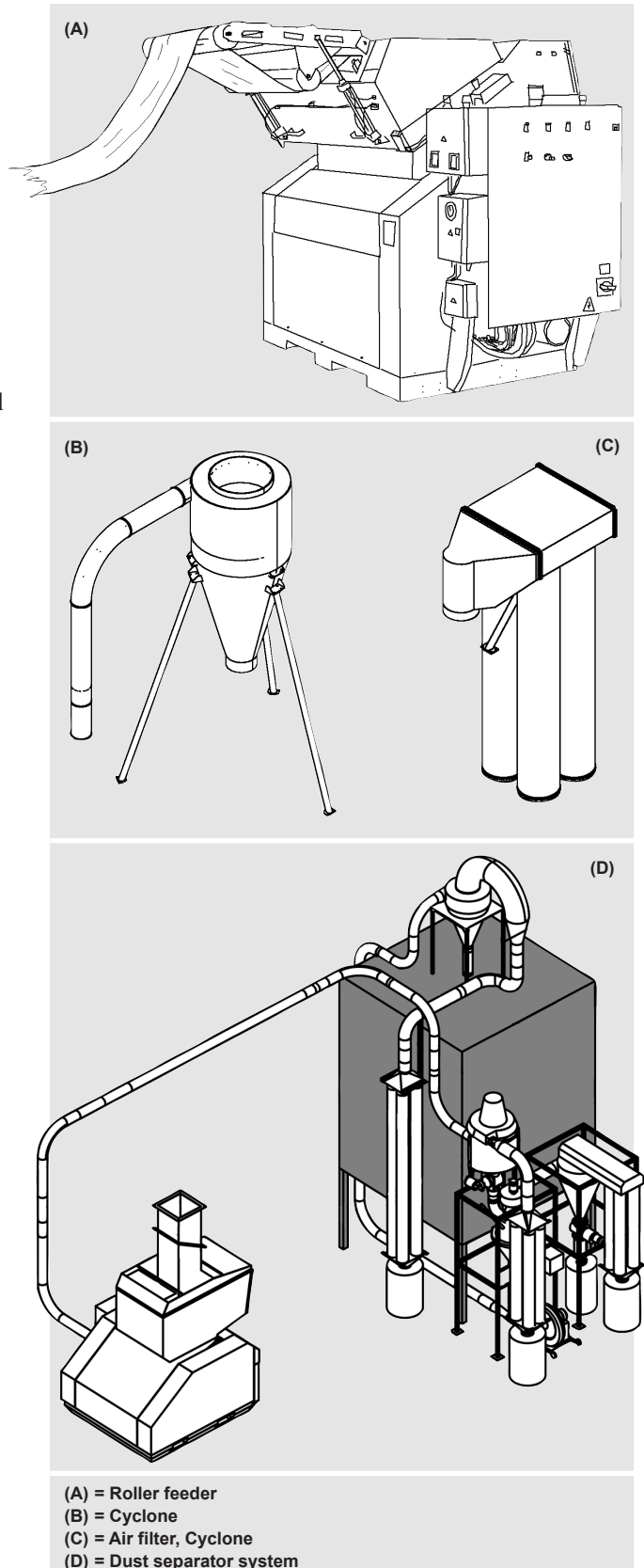

## Rotor, Rotating knives

### General rules, Rotor and rotating knives

The rotor is designed and adapted to the type of plastic residue that the customer has specified before order. The Conair NCF Series Granulators can be provided with several types of rotors. >Page 9:14–9:15 “Rotor”.

Rotating knives are mounted on the rotor. The granulator must never be used with blunt knives. Blunt knives cause abnormal wear and damages the granulator. The rotating knives must be replaced or grinded as necessary.

>Page 9:16–9:17 “Knives”.

### 3-blade open rotor

- The 3-blade open rotor has three knife rows with two rotating knives per row. Totally six rotating knives.
- There are two rotating knives in each knife seat. The rotating knives are fixed with support rules and tightening screws.
- The rotating knives are provided with adjusting screws which facilitates presetting of the knife clearance.  
>Page 7:17 “Preset the rotating knives”.
- The rotating knives can be grinded as necessary.  
>Page 7:15 “Grind the rotating knives”.

### 3-blade staggered rotor

- The staggered 3-blade rotor has three staggered knife rows with 2, 3, 4 or 5 rotating knives per row.
- NCF-810 has two rotating knives per row. Totally six rotating knives.
- NCF-814 has three rotating knives per row. Totally nine rotating knives.
- NCF-819 has four rotating knives per row. Totally twelve rotating knives.
- NCF-824 has five rotating knives per row. Totally fifteen rotating knives.
- The rotating knives are fixed with washers and tightening screws.
- The rotating knives are of disposable type and must be discarded and replaced as necessary.

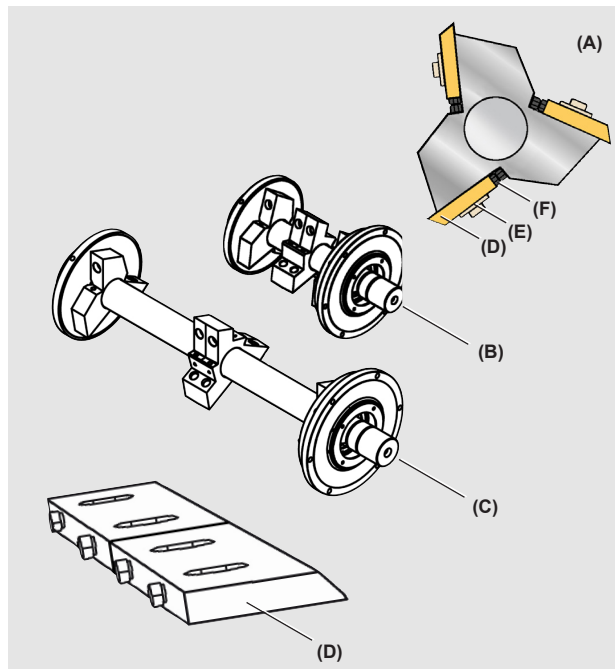

(A) = 3-blade open rotor  
(B) = 3-blade open rotor, NCF-810  
(C) = 3-blade open rotor, NCF-824  
(D) = Rotating knife, 3-blade open rotor  
(E) = Washer, 3-blade open rotor  
(F) = Adjusting screw, 3-blade rotor

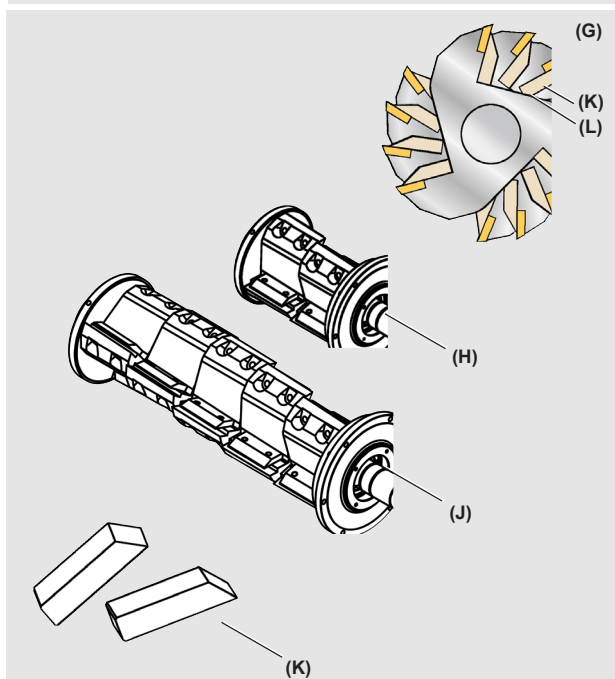

(G) = 3-blade staggered rotor  
(H) = 3-blade staggered rotor, NCF-810  
(J) = 3-blade staggered rotor, NCF-824  
(K) = Rotating knife, 3-blade staggered rotor  
(L) = Support rule, 3-blade staggered rotor

## Cutter housing, Fixed knives

### General rules, Cutter housing

The cutter housing is designed and adapted to the type of plastic residue that the customer has specified before order. Page 9:10–9:13 “Cutter housing”.

There are three types of cutter housings; cutter housing 1st “First”, cutter housing 3rd “Third” and cutter housing 5th “Fifth”.

### Cutter housing 1st

Cutter housing 1st has a tangential back. Cutter housing 1st has two knife seats: 1st and 2nd.

### Cutter housing 3rd

Cutter housing 3rd has a pre-cut back. Cutter housing 3rd has three knife seats: 3rd, 1st and 2nd.

### Cutter housing 5th

Cutter housing 5th has a super-tangential back. Cutter housing 5th has three knife seats: 1st and 2nd.

### Fixed knives

The cutter housing can be provided with two or three fixed knives, depending on type of cutter housing.

The rear fixed knife/knives is/are installed in the cutter housing’s back side. The rear fixed knife/knives is/are called “1st” and “3rd”.

The front fixed knife/knives is/are installed in the cutter housing’s front side. The front fixed knife/knives is/are called “2nd”.

NCF-810, NCF-814 and NCF-819 has one fixed knife in each knife seat. NCF-824 has two fixed knives in each knife seat.

The fixed knives are fixed with support rules and tightening screws.

The fixed knives are reversible. This means that the fixed knife has two cutting edges and can be reversed once before discarding is necessary.

The granulator must never be used with blunt knives. Blunt knives cause abnormal wear and damages the granulator.



Note! If a rear fixed knife is left out, it must be replaced by an original distance supplied by Conair.

>Page 9:16–9:17 “Knives”.

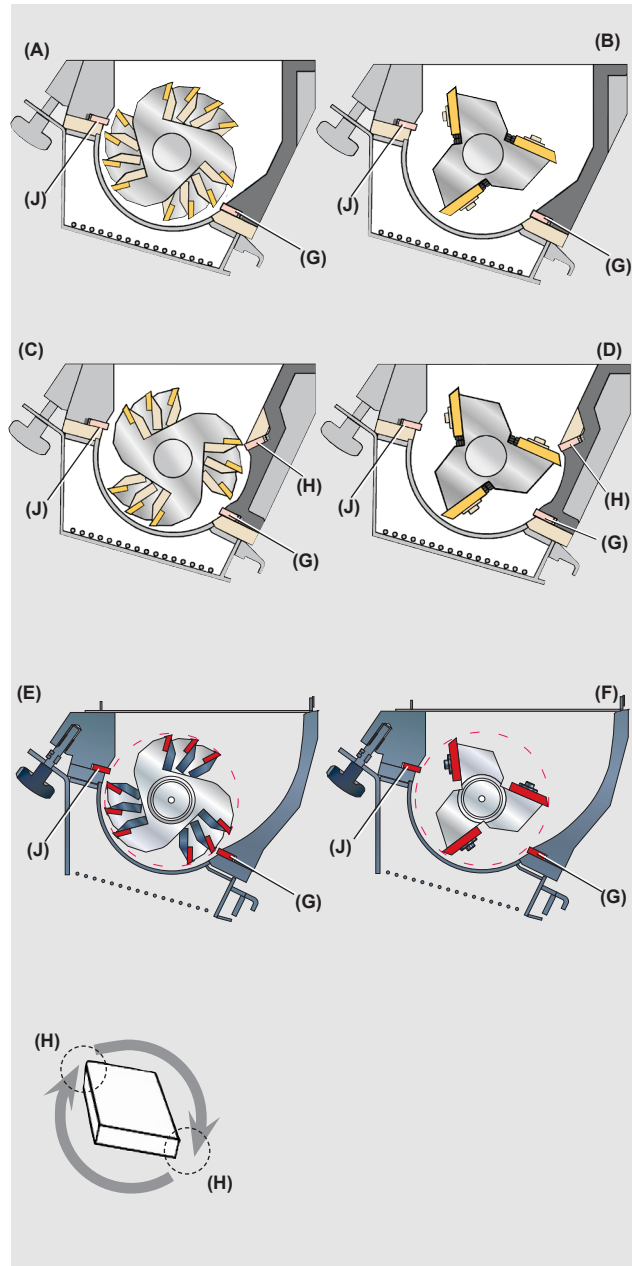

- (A) = Cutter housing 1st, 3-blade staggered rotor
- (B) = Cutter housing 1st, 3-blade open rotor
- (C) = Cutter housing 3rd, 3-blade staggered rotor
- (D) = Cutter housing 3rd, 3-blade open rotor
- (E) = Cutter housing 5th, 3-blade staggered rotor
- (F) = Cutter housing 5th, 3-blade open rotor
- (G) = Rear fixed knife 1st
- (H) = Rear fixed knife 3rd
- (J) = Front fixed knife 2nd
- (K) = Cutting edge, Fixed knife

## Knife clearance

The knife clearance is the gap between the fixed knife and the rotating knife. Correct knife clearance is .006–.010 in. {0.15–0.25 mm}. The knife clearance is checked with a feeler gauge. The knife clearance must be checked regularly. >Page 7:14 “Knife clearance”.

## Presetting fixture

The presetting fixture is used when presetting the knives’ adjusting screws. Presetting fixture is optional. Note! It is only possible to preset the open rotor’s rotating knives.

>Page 7:17 “General rules, Preset the knives”.

>Page 9:26 “Options”.

## Grinding fixture

The grinding fixture is used when grinding the knives. Grinding fixture is optional. Note! It is only possible to grind the open rotor’s rotating knives.

>Page 7:15 “General rules, Grind the knives”.

>Page 9:26 “Options”.

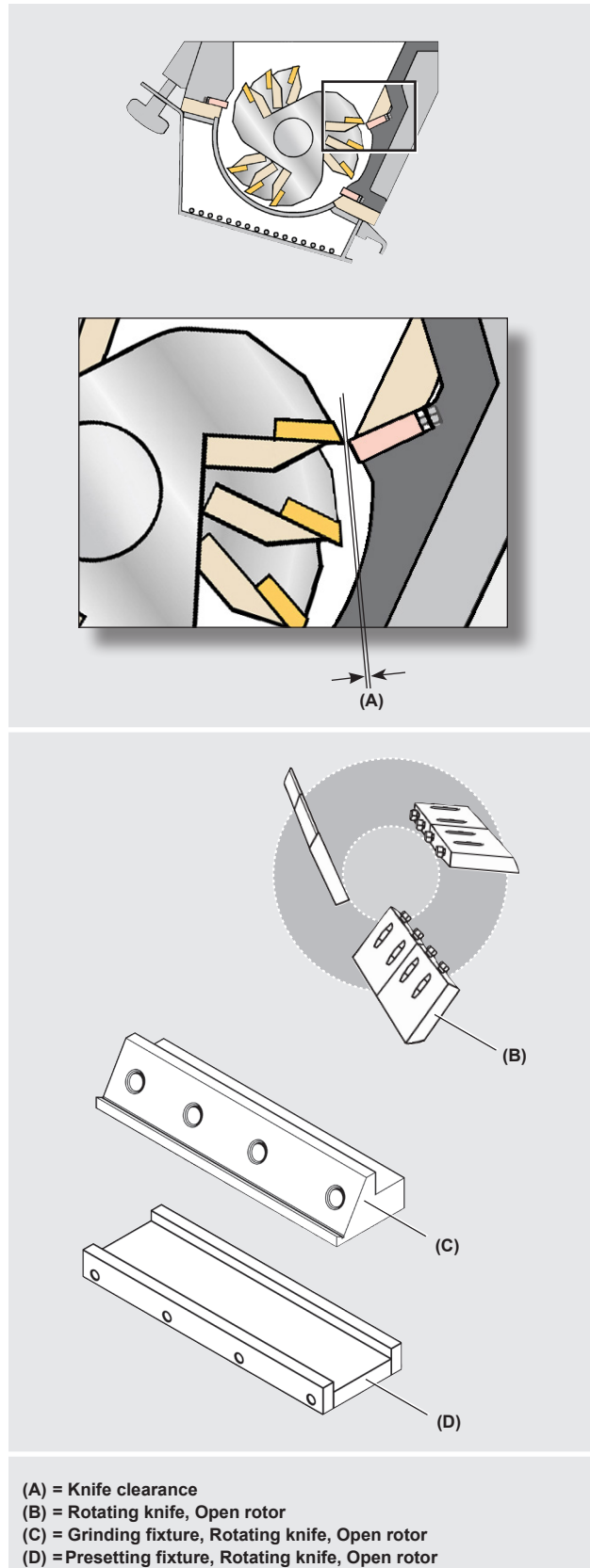

## Transmission

### Motor

The granulator is driven by an electric motor.

Optional motor power:

4.0 kW, 5.5 kW, 7.5 kW or 11 kW.

Optional rotor speed:

260 rpm (4.0 kW, 5.5 kW) or

406 rpm (7.5 kW, 11.0 kW).

Motor power and motor frequency are specified on the motor's machine plate.

>Page 9:22 "Transmission".

### Drive belt(s), Motor pulley, Rotor pulley

The granulator is provided with 3 or 4 drive belts depending on the motor power. The drive belts are tensioned between the motor pulley and the rotor pulley.

The drive belt(s) must be checked regularly. The granulator must not be driven with worn drive belt(s) nor with incorrect belt tension.

The belt tension is adjusted by moving the motor forwards / backwards. The motor is moved by tightening / unscrewing the front and the rear adjusting screws.

>Page 7:19 "Adjust the belt tension".

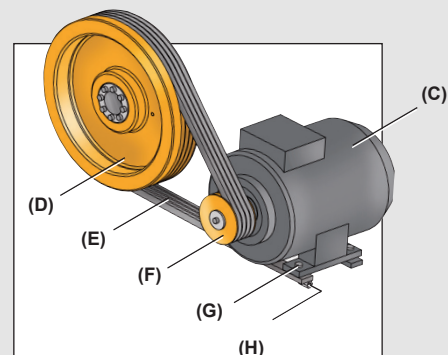
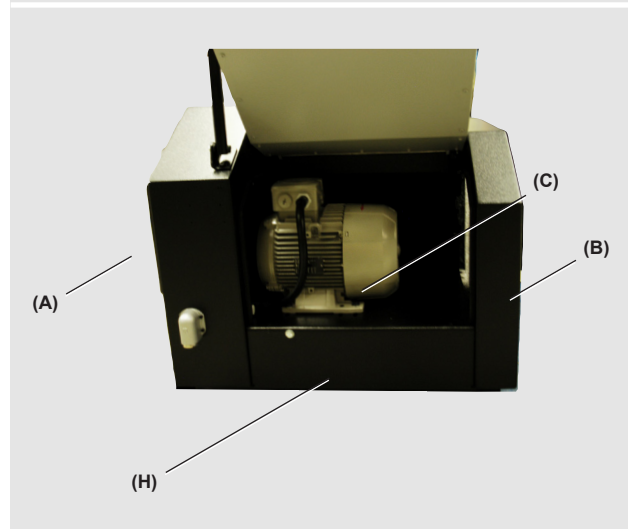
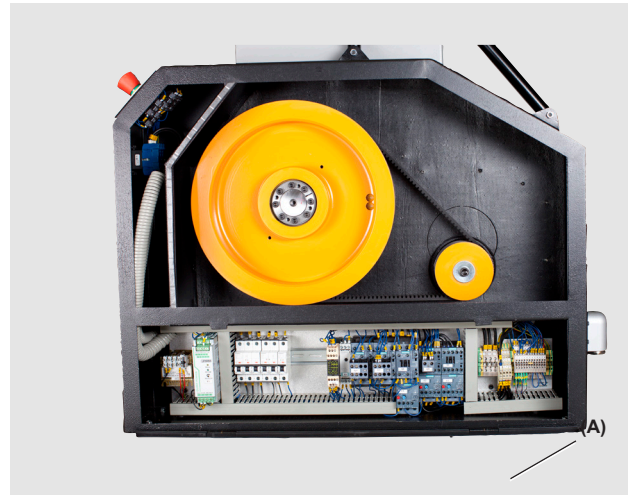

- (A) = Cover, Transmission
- (B) = Rear cover
- (C) = Motor
- (D) = Rotor pulley
- (E) = Drive belt(s)
- (F) = Motor pulley
- (G) = Tightening screws, Motor
- (H) = Adjusting screws, Belt tension

## Safety equipment

### General rules, Safety equipment



Inside the granulator, knives rotate at high speed. For this reason, there is safety equipment which is intended to prevent access to hazardous components during operation.

The safety equipment must not be changed or modified under any circumstances. If any part of the safety equipment is changed or left out, the machine can be dangerous to use.

The safety equipment must be checked regularly. No part of the safety equipment may be replaced by components other than spare parts supplied by Conair.

If any part of the safety equipment is changed or left out, Conair's responsibility under the Machinery Directive ceases to apply.

The safety equipment consists of:

- Hopper. >Page 2:17.
- Inlet (if supplied). >Page 2:17.
- Feed tray (if supplied). >Page 2:17.
- Funnel (if supplied). >Page 2:17.
- Flap(s). >Page 2:18.
- Screen. >Page 2:18.
- Screen box. >Page 2:18.
- Granule bin. >Page 2:18.
- Star knob. >Page 2:19.
- Safety sensor. >Page 2:19.
- Main switch. >Page 2:20.
- Emergency stop. >Page 2:20.



Note! All these parts must be installed during start and operation.

- In addition, the key for the electrical cabinet, transmission and pneumatic cabinets (if supplied), is part of the safety equipment. >Page 2:20.

## Safety equipment

### Hopper

The hopper is designed and adapted to the type of plastic residue that the customer has specified before order.  
>Page 9:5–9:6 “Hopper”.

The hopper must be closed during start and operation.  
>Page 6:4 “Close the hopper”.

A granulator with a light hopper is opened / closed manually. The light hopper is provided with one or two gas springs, which facilitates opening / closing.  
>Page 9:7–9:8 “Hopper device”.

A granulator with a heavy hopper is opened / closed by means of an electric jack. The electrical jack is controlled by the buttons “Operate 1” and “Operate 2”. Note! After stopping the machine the rotor keeps rotating for some minutes before it slows down and stands completely still. To ensure that the hopper will not be opened before the rotor has had time to stop completely, the buttons “Operate 1” and “Operate 2” are inactive for a couple of minutes. This means that it is not possible to open the machine immediately after stopping the machine. >Page 2:20 “Electrical cabinet”.

### Inlet

The hopper can be provided with an inlet. The inlet and the hopper prevent access to hazardous components during operation. The inlet (if supplied) must be installed during start and operation.

The inlet is designed and adapted to the type of plastic residue that the customer has specified before order.  
>Page 9:3–9:4 “Inlet”.

### Feed tray

The hopper can be provided with a feed tray. The feed tray and the hopper prevent access to hazardous components during operation. The feed tray (if supplied) must be installed during start and operation.

The feed tray is designed and adapted to the type of plastic residue that the customer has specified before order. >Page 9:3–9:4 “Feed tray”.

### Funnel

The hopper can be provided with a funnel. The funnel and the hopper prevent access to hazardous components during operation. The funnel (if supplied) must be installed during start and operation.

The funnel is designed and adapted to the type of plastic residue that the customer has specified before order.  
>Page 9:3–9:4 “Funnel”.

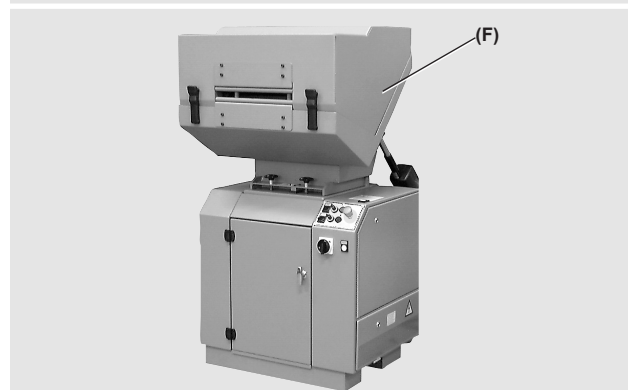
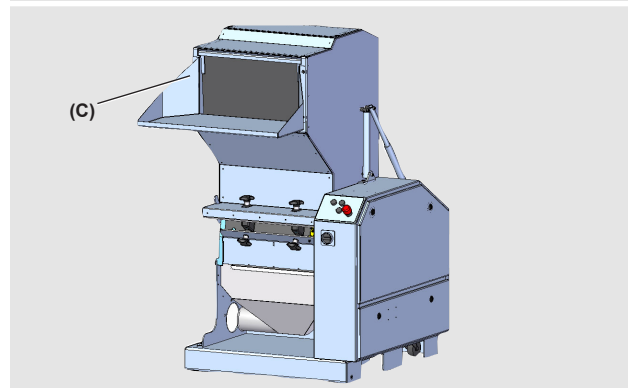
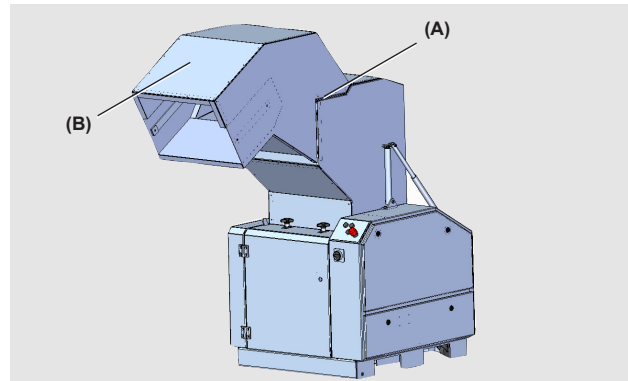

- (A) = Hopper
- (B) = Inlet
- (C) = Feed tray
- (D) = Funnel
- (E) = Hopper device, Gas spring
- (F) = Hopper device, Jack

## Safety equipment

### Flap(s)

The flap(s) prevents fed material from rejecting. The flap(s) also prevents half-finished granulate from stenching out of the inlet. The flap(s) must be installed during start and operation.

The flap(s) is/are designed and adapted to the type of plastic residue that the customer has specified before order. >Page 9:2 “Flap(s)”.

The flap(s) must be regularly checked and replaced as necessary. >Page 7:1 “Flap(s)”.

### Screen, Screen box

The screen prevents access to hazardous components during operation. The screen must be installed during start and operation.

The screen is designed and adapted to the type of plastic residue that the customer has specified before order. The screen can easily be changed to give the required granulate size. >Page 9:18 “Screen”.

The screen is installed in the screen box in the base of the cutter housing. The screen box must be closed during start and operation. The screen box is designed and adapted to the type of plastic residue that the customer has specified before order. >Page 9:15 “Screen box”.

The screen box is provided with star knobs and a safety sensor. >Page 2:19 “Star knob” and “Safety sensor”.

### Granule bin

The granule bin collects the finished granulate. The granule bin must be closed during start and operation.

The granule bin is designed and adapted to the type of plastic residue that the customer has specified before order. >Page 9:20 “Granule bin”.

The granule bin can be provided with a level switch (option). >Page 2:22 “Level switch”.

The granule bin can be provided with a blower (option). >Page 2:10 “Blower Option”.

The granule bin can be provided with a star knob and a safety sensor. A granulator with 8 or 10 mm screen is provided with an extra safety sensor and a star knob at the granule bin. >Page 2:19 “Star knob” and “Safety sensor”.

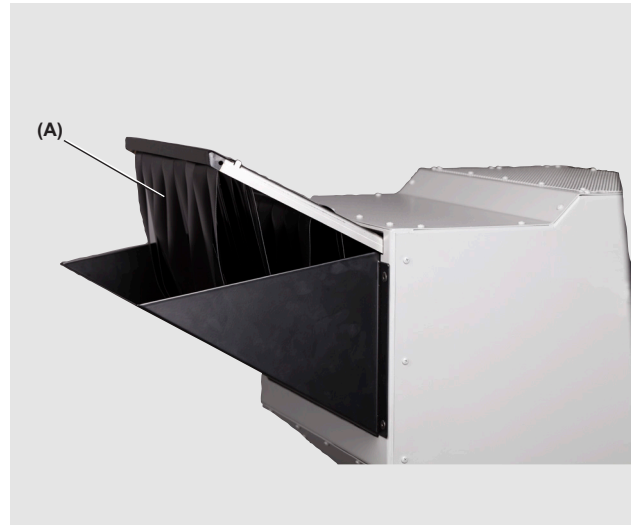

(A) = Flap(s)  
 (B) = Screen  
 (C) = Screen box  
 (D) = Granule bin

## Safety equipment

### Star knob

The machine can be provided with several star knobs. The star knob has a screw with a very long thread. The thread is so long because it has to take such a long time to unscrew the star knob that the rotor will have time to stop completely.

The star knob(s) must be checked regularly. A star knob with worn screw must only be replaced with a new original screw supplied by Conair.

The design and location of star knobs can vary. Examples of where star knobs might be located can be seen in the figure on the right.

The star knob(s) must be checked regularly.  
>Page 7:2 “Safety equipment”.

### Safety sensor

The machine can be provided with several safety sensors. The safety sensor consists of two sensors parts who sends/receives signals to/from each other. The safety sensor stops the machine if its two parts are separated. To be able to start the machine, the two parts must be near each other and a green light should be lit on one of the sensor parts.

The design and location of safety sensors can vary. Examples of where safety sensors might be located can be seen in the figure on the right. The electrical circuit diagram shows the number of safety sensors installed in the supplied machine.

The safety sensors must be checked regularly.  
>Page 7:2 “Safety equipment”.

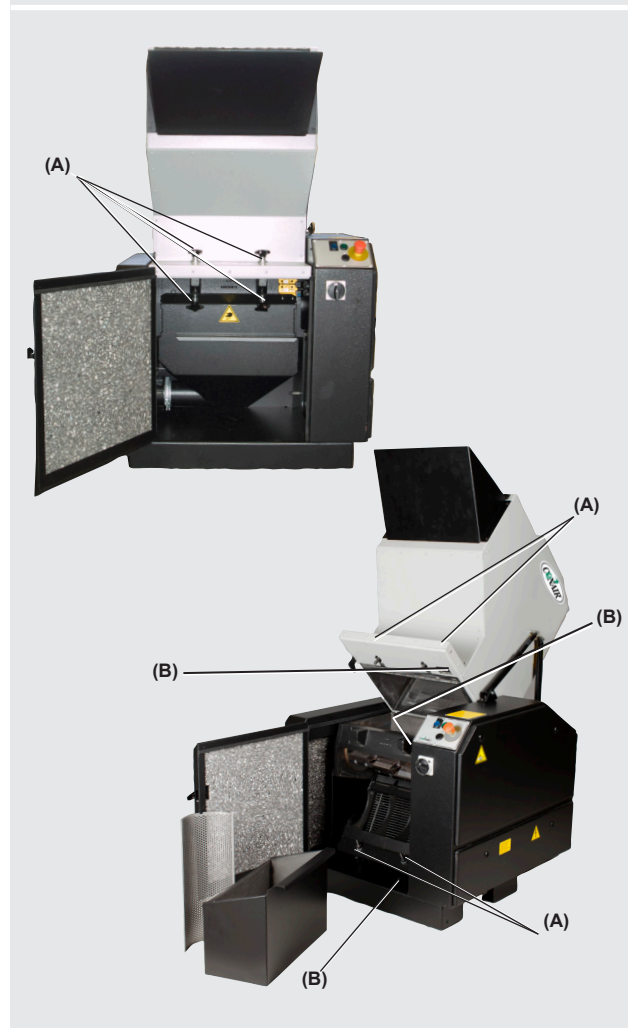
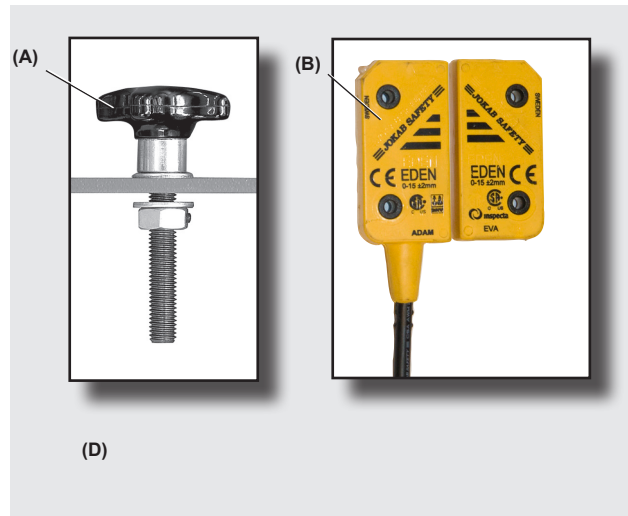

(A) = Star knob  
(B) = Safety sensor

## Safety equipment

### Key to the electrical cabinet

All hatches to electrical cabinet, transmission and pneumatics (if supplied) must be closed and locked during start and operation. The key must be kept by the personnel responsible for the machine's service and safety.

### Electrical cabinet, Operating panel

The machine's control knobs are found on an operating panel. The machine can be provided with several operating panels. The design and location of the operating panel(s) and the knob(s) can vary. Refer to the electrical circuit diagram.

### Main switch

The main switch cuts all 3 phases of the supply voltage. The design and location of the main switch can vary. The granulator's main switch must be locked in position "0" during service.

### Emergency stop

The emergency stop stops the machine in case of emergency. The machine can be provided with several emergency stops. The emergency stop(s) must be checked regularly. >Page 7:1 "Emergency stop(s)".

The design and location of the emergency stop(s) can vary. The electrical circuit diagram shows the number of emergency stop(s) installed in the supplied machine.

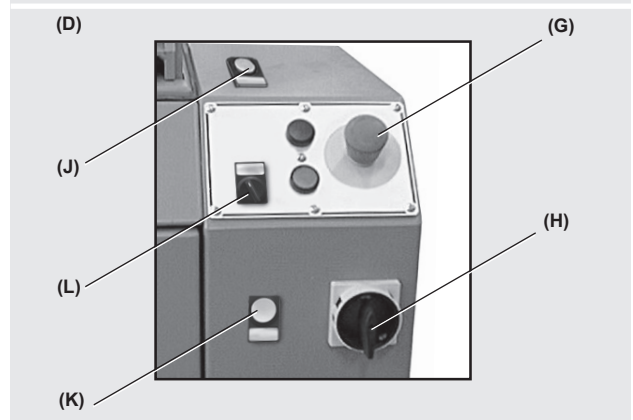
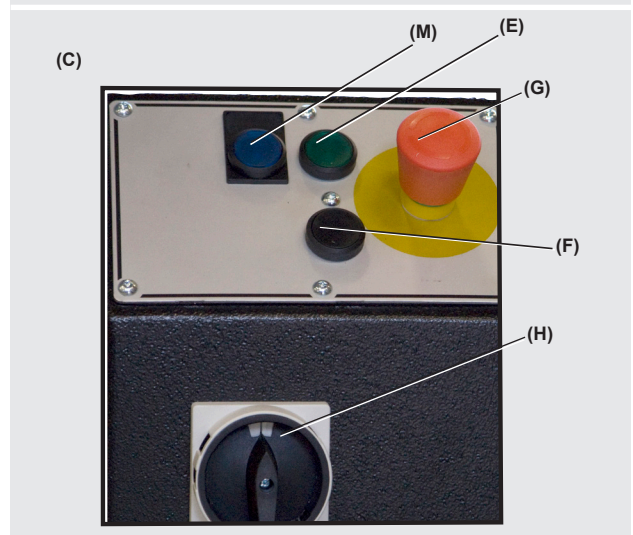
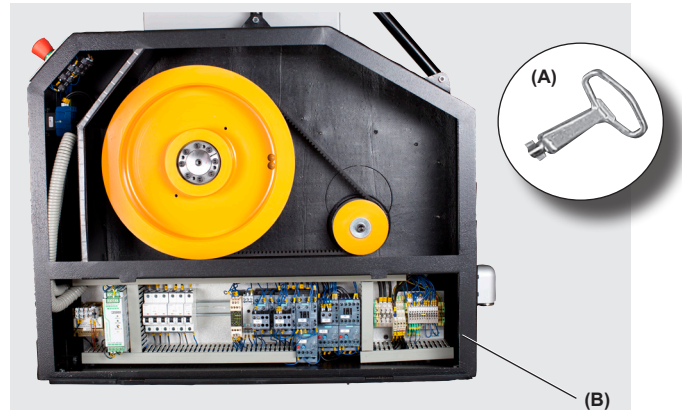

- (A) = Key to the electrical cabinet
- (B) = Electrical cabinet
- (C) = Operating panel, Granulator with light hopper
- (D) = Operating panel, Granulator with heavy hopper
- (E) = Start-button
- (F) = Stop-button
- (G) = Emergency stop
- (H) = Main switch
- (J) = Button "Operate 1"
- (K) = Button "Operate 2"
- (L) = Knob "Hopper, Close / Open"
- (M) = Button "Reset safety relays"

DESCRIPTION

## Overload protection

### General rules, Overload protection

The machine can be provided with several overload protections. The electrical circuit diagram shows the number of overload protections installed in the supplied machine. The overload protection(s) is/are installed inside the electrical cabinet.

The overload protection trips if the granulator or any optional equipment is overloaded. Before resetting an overload protection and before restarting the machine, the reason why the overload protection tripped must be determined. Take necessary actions (for example clean the machine) to prevent the overload protection from immediate tripping when restarting the machine.

### Overload protection, overload relay

If the overload display shows “0” the overload protection has tripped.

If the reset button is in auto mode “A”, the overload protection resets automatically after 2 minutes.

If the reset button is in manual mode “M”, the overload protection must be manually reset by pressing the reset button.

### Overload protection, motor circuit breaker

If the reset knob is in position “0” the overload protection is manually turned off. If the reset knob is in a position between “0” and “1” the overload protection has tripped. The overload protection is reset by turning the reset knob to position “0” and them to “1”.



(A)

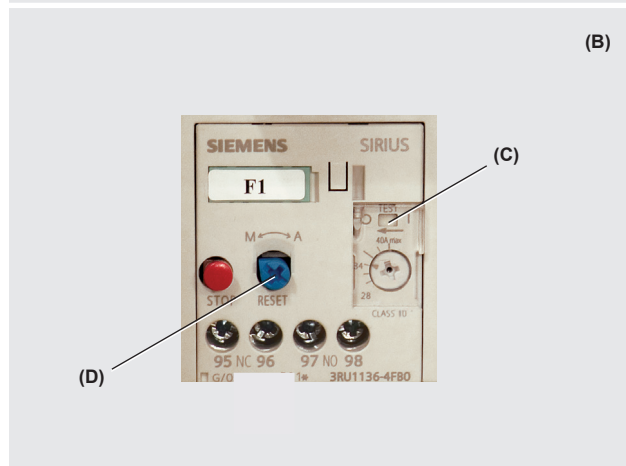

(B)

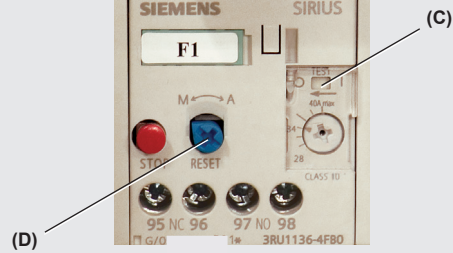

(C)

(D)

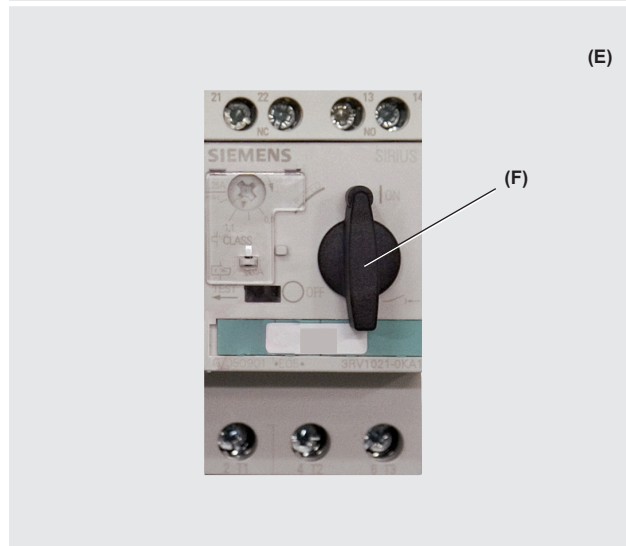

(E)

- (A) = Electrical cabinet
- (B) = Overload protection, Type F1
- (C) = Overload display
- (D) = Reset button
- (E) = Overload protection, Type Q4
- (F) = Reset knob

## Level switch

### General rules, Level switch

The granule bin can be provided with a level switch (option). The level switch monitors the granulate level in the granule bin. As the granulate level gets too high, the level switch takes one or several of the below listed actions:

- Stops the granulator.
- Stops optional feed equipment (such as a band conveyor or a roller feeder).
- Lights up a warning lamp (option).
- Starts up a siren (option).
- Resets the level switch and restarts the granulator and/or the feed equipment as the granulate level in the granule bin has sunk.

The electrical circuit diagram specifies the actual function of the level switch in the supplied machine.

### Level switch, Paddle type

A level switch of paddle type, is provided with rotating paddles. When the granulator is started the paddles starts rotating. If the granulate level gets too high, the paddle is prevented from rotating which cause the switch output to activate.

The sensitivity is adjustable. On delivery the adjusting spring is installed on “Weak” and it can be adjusted to “Strong“. > Page 7:3 point 4 “Level switch”.

### Hour counter

The granulator can be provided with an hours counter (option). The hours counter counts the time the rotor is rotating. The hours counter has no reset.

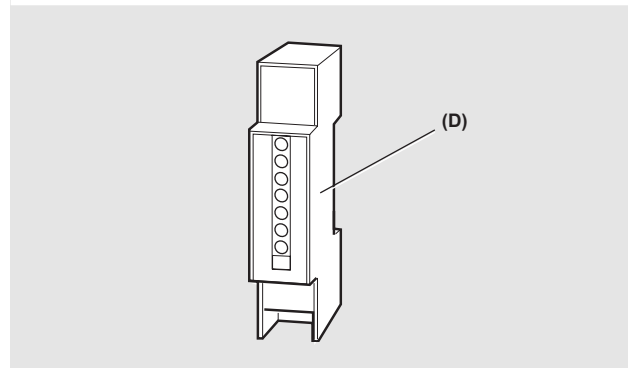
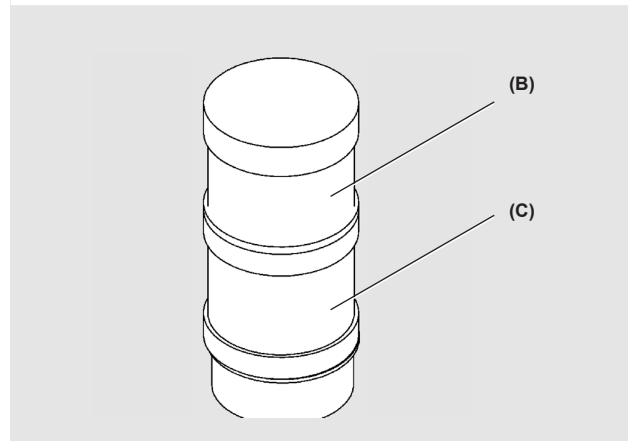
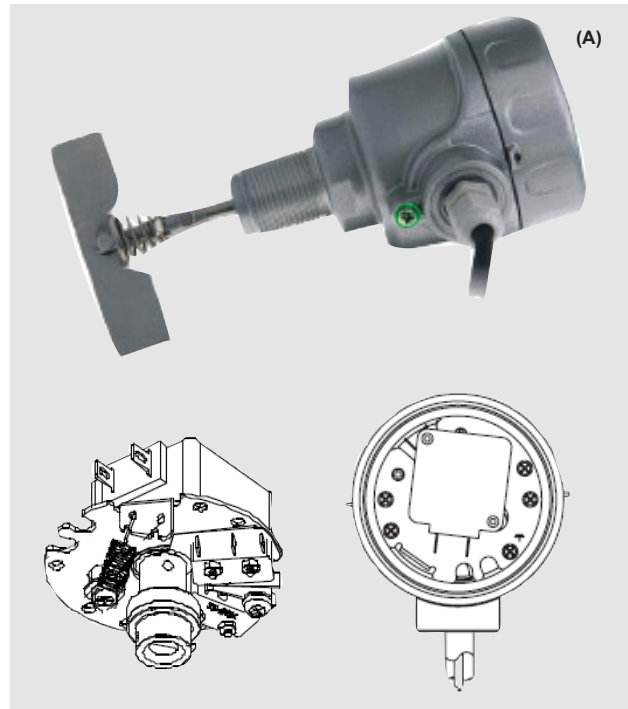

- (A) = Level switch, Paddle type  
 (B) = Siren, Level switch  
 (C) = Warning lamp, Level switch  
 (D) = Hours counter

## Function settings current relay - overcurrent detector (option)

### Application of current relay

When a current relay is installed it is either used to protect the granulator from a too high current level (which can damage the motor) or for detecting when granulator is idle running (detecting idle current level).

When a current relay is used as an overcurrent detector the current relay should detect when the current exceeds the nominal current.

### Functions

The functions that are adjustable are:

- Overcurrent detection "Excess current"  $I^{\wedge}$ 
  - To adjust this function; see next page
- Undercurrent detection - "Under current"  $I_{\vee}$ 
  - Is not used on Conair's granulators.
  - Should be set to "OFF".
- Delay of detection when a overcurrent detection has occurred:  $I^{\wedge}$ Delay ( $T_1$ )
  - Is adjustable but is at delivery set to "3.0 s".
- Delay of detection when a undercurrent detection has occurred:  $I_{\vee}$ Delay
  - It is not possible to adjust if  $I_{\vee}$  is set to OFF.
  - Should not be used or adjusted.
- Delay of detection at startup: onDelay ( $T_2$ )
  - Is not used on Conair's granulators.
  - Is set to "0.0 s" and should not be adjusted.
- Memory: "Mem?"
  - Should be set to "No".
  - If "Mem?"- Yes", when a detection occur the relay remain in status "detected" until the power is cut. If "Mem?" - No", when a detection occur the current level has to decrease (or increase) to a level under (or over) the overcurrent (undercurrent) level to change from status "detected". How much the current level has to decrease (or increase) in relation to the detection value is called hysteresis.
- Hysteresis (HA): "Hyst"
  - To adjust this function; see next page.
- The panel "NC Us=on" should always be set to "NC Us=on". When this panel is changed, the relay works as if all settings were adjusted with the opposite setting.

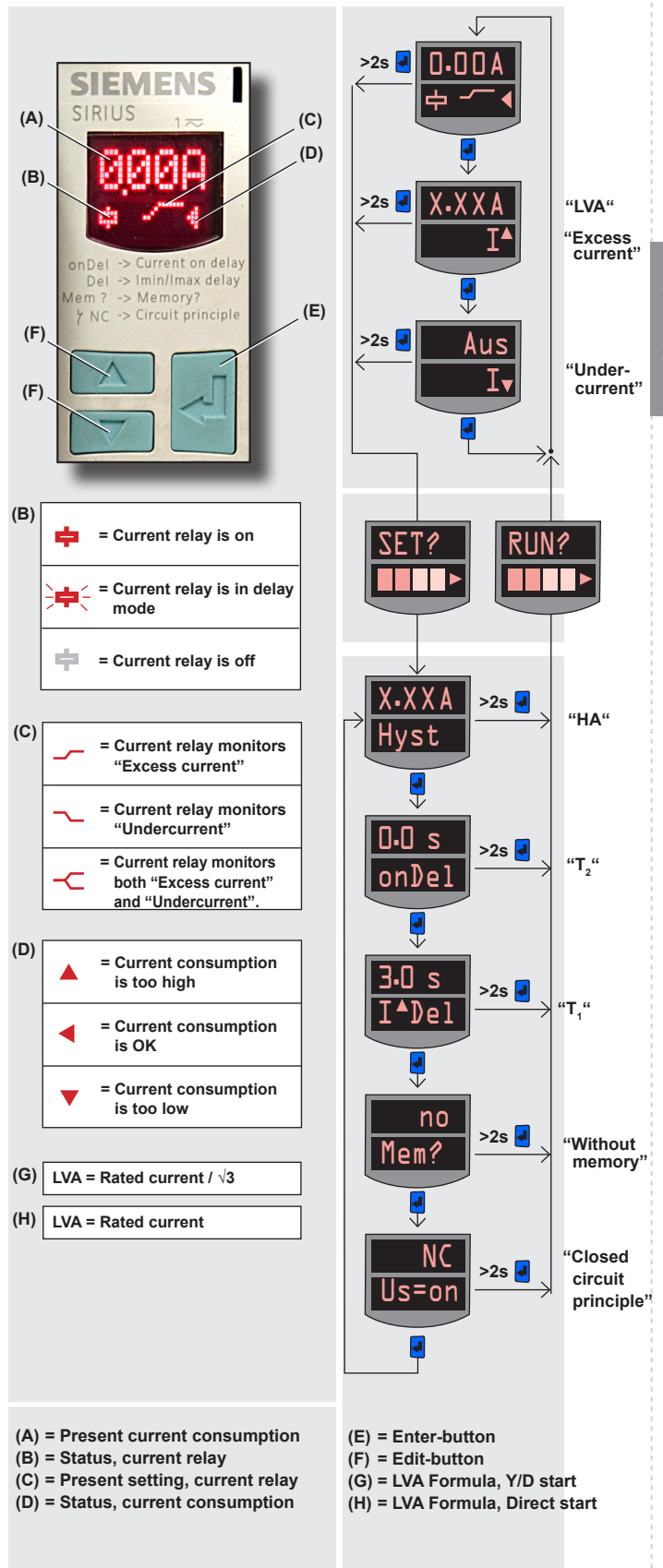

## Function settings current relay - overcurrent detector (opzione)

### Parameters that affects overcurrent detection

- Rated current, motor
- LVA (Limit value, Ampere)
  - Is calculated according to formula (G) or (H) depending on if the granulator is Y/D started or Direct started. (G) if granulator is Y/D started and (H) if granulator is direct started or if it is Y/D-started has and has a visual ammeter.
  - Overcurrent detection value should be set to LVA-value or slightly lower.
- HA (hysteresis, ampere)
  - Hysteresis (HA) should be set to a value lower then the LVA-value. Around one tenth of the LVA-value.
- The panel "NC Us=on" should always be set to "NC Us=on".

### Check of function settings - overcurrent detection

- Decrease the overcurrent detecting value,  $I^{\wedge}$ , to a level lower then idle current level. If the relay detects overcurrent the relay works correctly.
- Increase the overcurrent detecting value,  $I^{\wedge}$ , with approximately 12% (if HA is 10% of LVA). If HA is higher than 10% of LVA the overcurrent setting needs to be increase further.

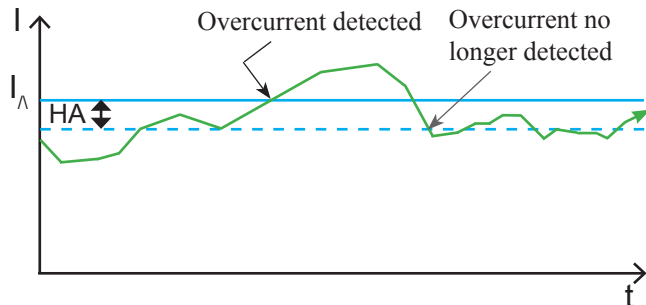

DESCRIPTION

(B)

|  |                                  |
|--|----------------------------------|
|  | = Current relay is on            |
|  | = Current relay is in delay mode |
|  | = Current relay is off           |

(C)

|  |  |
|--|--|
|  | = Current relay monitors "Excess current"                          |
|  | = Current relay monitors "Undercurrent"                            |
|  | = Current relay monitors both "Excess current" and "Undercurrent". |

(D)

|  |                                   |
|--|-----------------------------------|
|  | = Current consumption is too high |
|  | = Current consumption is OK       |
|  | = Current consumption is too low  |

(G) LVA = Rated current /  $\sqrt{3}$

(H) LVA = Rated current

(E) = Enter-button  
(F) = Edit-button  
(G) = LVA Formula, Y/D start  
(H) = LVA Formula, Direct start

## Function settings current relay- Idle running detection (option)

### Application of current relay

When a current relay is installed it is either used to protect the granulator from a too high current level (which can damage the motor) or for detecting when granulator is idle running (detecting idle current level).

When a current relay is used for detecting idle current the current relay should detect when the current level is lower than the “overcurrent value”. The overcurrent value should be slightly higher than idle current level.

### Functions

The functions that are adjustable are:

- Overcurrent detection “Excess current”  $I^{\wedge}$ 
  - Set to slightly higher than idle current level
- Undercurrent detection -”Under current”  $I_{\vee}$ 
  - Is not used on Conair’s granulators.
  - Set to “OFF”.
- Delay of detection when a overcurrent detection has occurred:  $I^{\wedge}$ Delay ( $T_1$ )
  - This function wont affect the current relay while it is used for idle current detection.)
- Delay of detection when a undercurrent detection has occurred:  $I_{\vee}$ Delay
  - It is not possible to adjust if  $I_{\vee}$  is set to OFF.
  - Should not be used or adjusted.)
- Delay of detection at startup: onDelay ( $T_2$ )
  - Is not used on Conair’s granulators.
  - Is set to “0.0 s” and should not be adjusted.
- Memory: ”Mem?”
  - Should be set to “No”.
  - If ”Mem?- Yes”, when a detection occur the relay remain in status “detected” until the power is cut. If ”Mem? - No”, when a detection occur the current level has to decrease (or increase) to a level under (or over) the overcurrent (undercurrent) level to change from status “detected”. How much the current level has to decrease (or increase) in relation to the detection value is called hysteresis.
- Hysteresis (HA): ”Hyst”
  - The hysteresis value should be set to 0.0 A.
- The panel “NC Us=on” should always be set to “NC Us=on”. When this panel is changed, the relay works as if all settings were adjusted with the opposite setting.

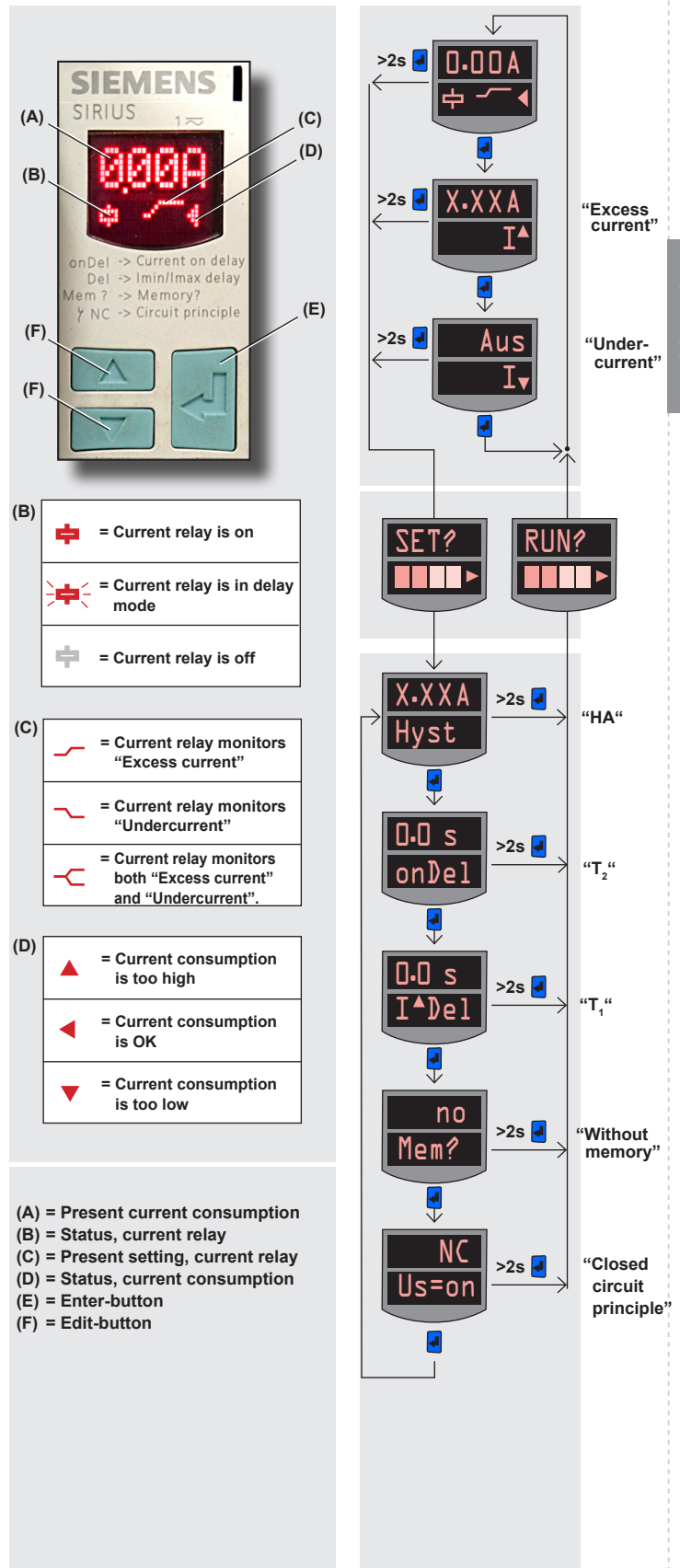

## Function settings current relay- Idle running detection (option)

### Parameters that affects idle running detection

- Idle current level. Set overcurrent detection value to a little more than idle current level (approximately 0,1-0,2 A over idle current level).
- The hysteresis value should be set to 0.0 A.
- The panel “NC Us=on” should always be set to “NC Us=on”.

### Check of function settings - Idle running detection

- Increase the overcurrent setting value to a level higher than idle current level. If the relay detects idle running the relay works correctly.
- Decrease the overcurrent setting value lower than idle current level. The relay should not detect idle running.

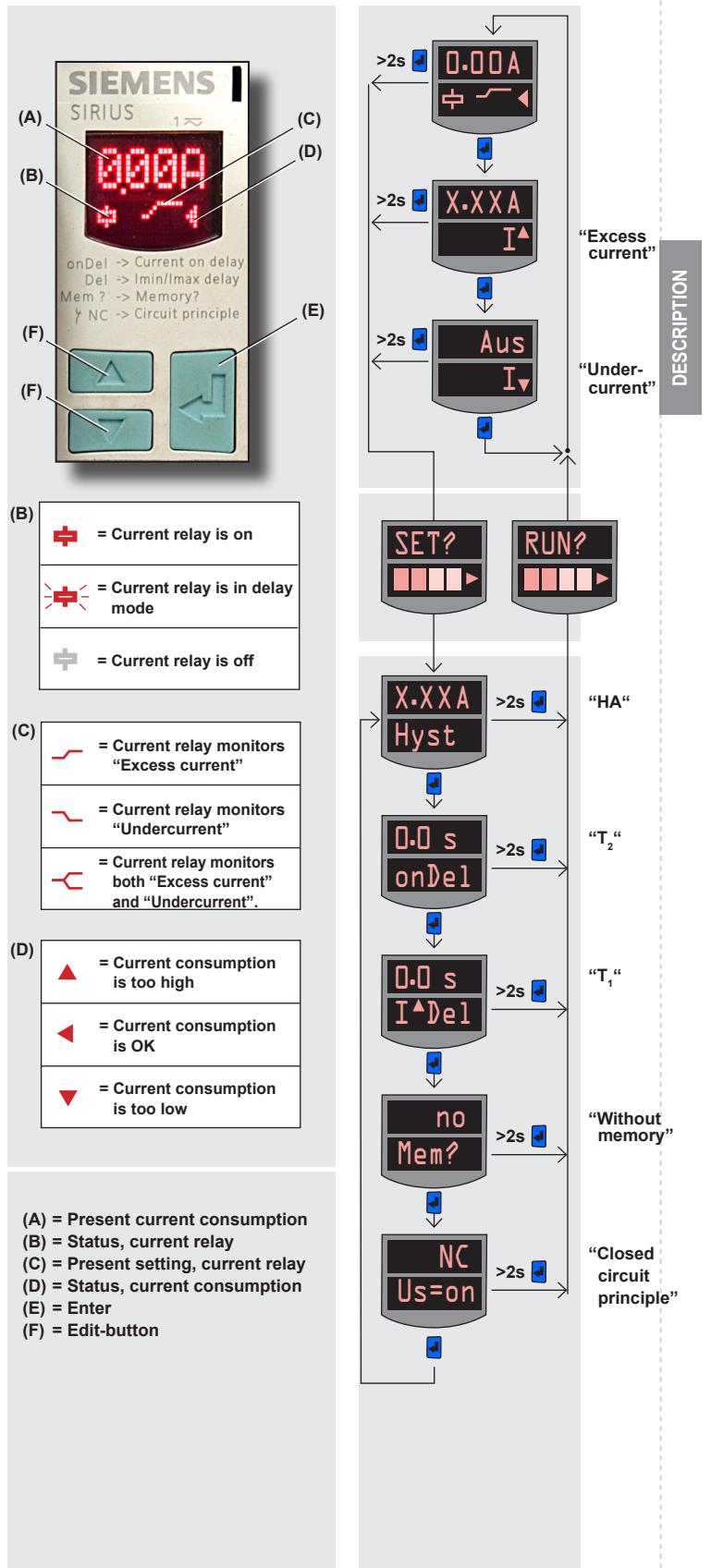

## Transport / Lift

### General rules, Transport / Lift

The machine must only be transported / lifted by trained personnel. All instructions must be observed to avoid personal injury and machinery damage.

### Transport

1. If the machine will be transported exposed to weather and wind: Treat all components that could rust with a rust preventer. Wrap the machine in plastic foil.
2. Machine with wheels: If the machine will be transported a shorter distance on even, dry ground: Transport the machine with its wheels.
3. If the machine will be transported a longer distance or on uneven ground: Fix the machine to a transport pallet with tension straps. Transport / lift the pallet with a fork lift.

### Lift the granulator

1. Close the granulator. >Page 6:4–6:6.
2. Use a fork lift. Insert the forks as shown in figure on the right. Adjust the forks to maximum width. The forks must tangent the inside of the granulator's machine shoes / wheels to prevent the granulator from overbalancing when lifted.
3. Check that no cables or any parts of the safety equipment are pinched when lifting.
4. Lift the granulator. Make sure that the machine will not overbalance when lifted. For information about machine weight, refer to page 2:1 "Technical specifications".



## Actions before first start

---

### General rules, Installing

1. Read page 1:2 “Safety rules, During installing”.
2. Read all of chapter 4 before installation is started.
3. Sign the completed installation, in the end of this chapter.

### Reception inspection

1. Check the dispatch note to ensure that the delivery is complete.
2. Check that the machine has not been damaged during transport. Any damage must be reported to the forwarding agent.

### Put the machine in its working place

1. Refer to layout for required working space.  
>Page 2:3–2:8 “Layout”.
2. Transport / lift the machine to its working area.  
>Page 3:1 “Transport / Lift”.
3. Check that the machine stands horizontal and steady.  
Use a spirit level.

## Actions before first start

### Remove the rust preventer

Un-painted components are treated with rust preventer before delivery and transport. Remove the rust preventer before operating the machine.

1. Read page 7:7 “Cleaning”.
2. Clean following parts inside and outside: Hopper, Cutter housing, Rotor, Knives, Screen, Screen box, Granule bin. Use a low aromatic alkaline degreaser or a gentle solvent. Wipe clean with lint-free rags.

### Check the knife clearance

1. Check the knife clearance. >Page 7:14.

### Technical specifications

1. Fill in correct information, on page 2:1 “General data, Supplied machine”, so that the data corresponds with the machine sign on your supplied machine.
2. Mark the correct alternatives, on page 2:1 “General data, NCF-series”, so that the data corresponds with your supplied machine.
3. Sign the personnel responsible for the machine’s service and safety, on page 2:1.



- (A) = Hopper
- (B) = Cutter housing
- (C) = Rotor
- (D) = Screen
- (E) = Screen box
- (F) = Granule bin

## Electrical connection

### General rules, Electrical connection



1. Read page 4:1 “General rules, Installing”.
2. The machine must be disconnected from the mains before electrical repairs or electrical installing is begun.
3. The machine must be installed in accordance to EN 954-1 Category 3. This means that all cables must be installed so that they will not get damaged during operation.
4. All electrical service, must be done by authorized, trained personnel. No modifications or alterations of the basic electrical settings are permissible unless a written approval has been obtained from Conair’s head office. Refer to the electrical circuit diagram.
5. When replacing electrical components, only use original spare parts supplied by Conair. >Page 9:1 “Spare parts”.

### Emergency stop(s)

1. Read page 4:3 “General rules, Electrical connection”.
2. Check that the supplied emergency stop is within reach at all positions in the machine’s workplace.
3. If the supplied emergency stop is not accessible from all positions in the workplace, the machine must be provided with further emergency stops.

In event of any questions, please contact Conair’s local distributor or Conair’s head office.

### Connect the granulator to the mains

1. Read page 4:3 “General rules, Electrical connection”.
2. Check the phase sequence of the electric mains with a phase sequence display. The granulator is connected for a right-hand turning field. The electric circuit diagram specifies the connection voltage (Volt) and fuse size (Ampere).
3. Connect the granulator to the electrical cabinet.
4. Connect the electrical cabinet to the mains.

## Start the granulator

1. Check that all actions in page 4:1–4:3 are done.
2. Check that all parts of the safety equipment are installed. >Page 2:16.
3. Close the granulator. >Page 6:4–6:6.
4. Start the granulator. >Page 5:1.

### Checks immediately after first start

1. Check that the rotating direction of the granulator's motor corresponds to the arrow on the motor.
2. Additional suffix -U (Blower):  
 Check that the blower's rotating direction corresponds to the arrow on the blower. The blower is functioning even when the rotation direction is wrong, but if the blower's rotating direction is wrong the blower's capacity decreases considerably.
3. If the rotating direction is wrong:
  - a) Stop the granulator. >Page 5:1.
  - b) Read page 4:3 "General rules, Electrical connection".
  - c) Switch over two incoming phases.
  - d) Start the granulator. >Page 5:1.
4. Additional suffix -B (Band conveyor):  
Check the band conveyor. >Page 7:5.
5. Check the emergency stop(s). >Page 7:1.
6. Check the safety equipment. >Page 7:2.
7. Check the knife clearance. >Page 7:14.
8. Level switch (option): Check that the level switch's setting is satisfying. Adjust as necessary. >Page 7:3.
9. Current relay (option): Check that the current relay's setting is satisfying. Adjust as necessary. >Page 7:4.



## Checks 30 hours after first start

---

1. Stop the granulator. >Page 5:1.
2. Check the knife clearance. >Page 7:14.
3. Check the drive belt(s). >Page 7:18.
5. Check the tightening torque on important machine parts. >Page 7:6.

## Installing complete

---

The machine has been installed and checked in accordance with the instructions in chapter 4.

Date: ..... / ..... 20 .....

Name:.....

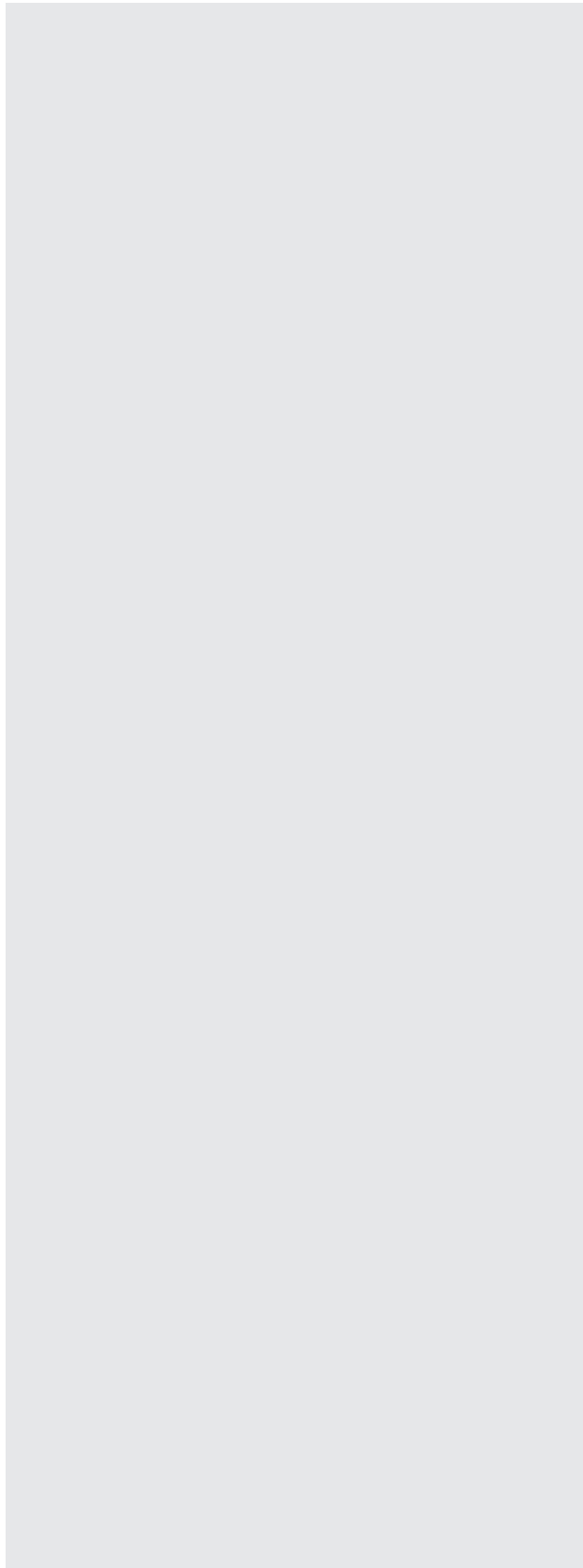

INSTALLING

## Start the granulator

1. Read page 1:3 “Safety rules, During start and operation”.
2. Check that there is no material in hopper or cutter housing.



Important! The granulator must not be started if there is material left in the hopper and cutter housing. When starting, remaining material may brake the rotor and overload the motor. The overload protection will trip and the granulator will stop.



Important! A granulator with blower must not be started if there is material left in granule bin, outlet pipe or blower. When starting, remaining material in the blower, outlet pipe or granule bin can cause serious and irreparable damage to the blower.

3. Put the main switch in position “1”.
4. Reset the emergency stop(s).
5. Reset the safety relays by pushing the button Reset safety relay.
6. Start the granulator. Press the start-button.
7. The granulator is started.



Information! If the granulator or optional equipment does not start once the above points have been attended to, read page 7:20 “Fault tracing”.

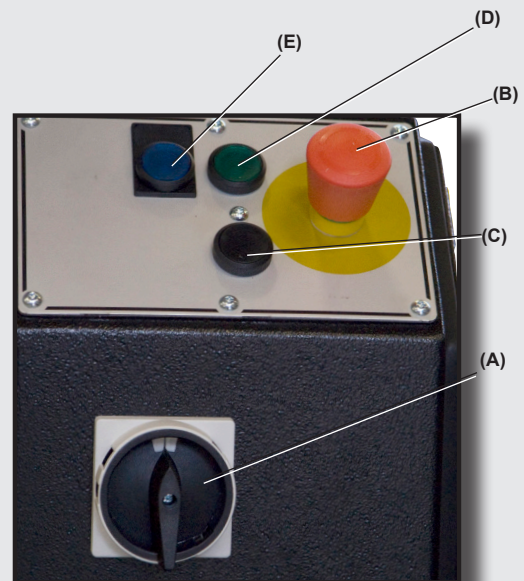

- (A) = Main switch  
 (B) = Emergency stop  
 (C) = Stop-button  
 (D) = Start-button  
 (E) = Reset safety relay-button

## Stop the granulator

1. Stop feeding material. Wait until all material have been fully granulated.



Important! Do not stop the granulator until all material in hopper and cutter housing have been fully granulated.



Important! A granulator with blower must not be stopped until all material have been transported out of the granule bin and the blower.

2. Stop the granulator. Press the stop-button.
3. Press the emergency stop(s).
4. Lock the main switch in position “0”.
5. The granulator is stopped.

## Open the granulator

### General rules, Open the granulator

1. Read page 1:4 "Safety rules, During service".
2. Stop the granulator. >Page 5:1.
3. Additional suffix -B (Band conveyor):  
Remove the band conveyor.

### Open the enclosure

1. Read page 6:1 "General rules, Open the granulator".
2. Open the enclosure's door(s). Pull the enclosure's handle. Open the door(s) 90°.
3. Open the enclosure's rear cover. Unscrew the rear cover's screwdriver lock. Remove the rear cover by lifting it away; in the bottom of the cover plugs exist to hold the cover in place.
4. The enclosure is opened.

### Open the transmission

1. Read page 6:1 "General rules, Open the granulator".
2. Remove the enclosure's rear cover.  
>Page 6:1 point 3 "Open the enclosure".
3. Remove the transmission cover. Unscrew the transmission cover's screwdriver lock.
4. The transmission is available.

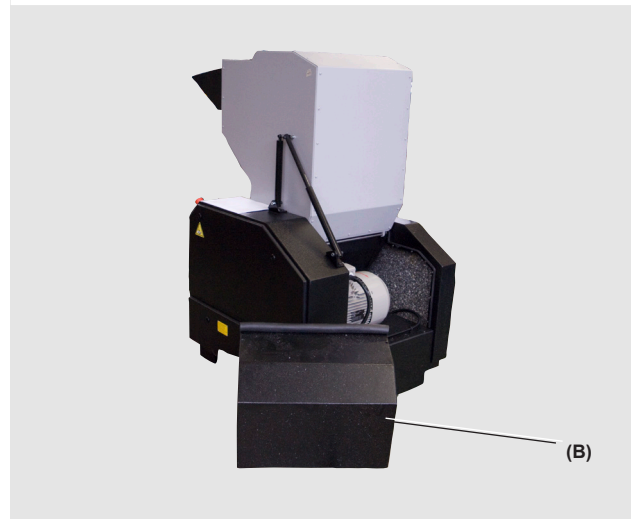
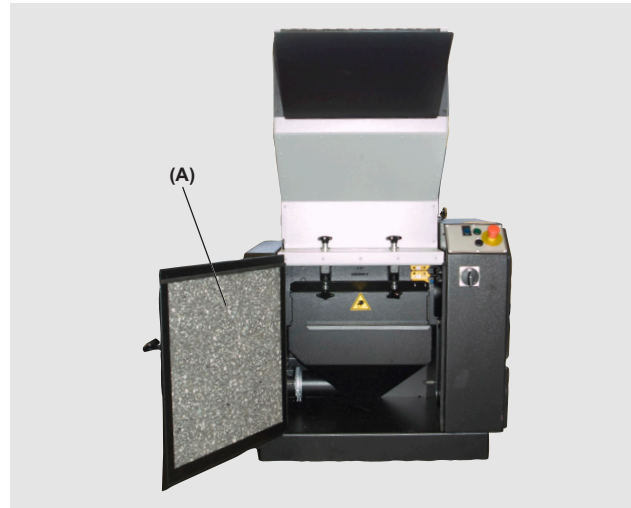

(A) = Door, Enclosure  
(B) = Rear cover, Enclosure  
(C) = Cover, Transmission

## Open the granulator

### Open the granule bin

1. Read page 2:18 “Granule bin”.
2. Read page 2:19 “Star knob” and “Safety sensor”.
3. Open the enclosure’s door(s). >Page 6:1 point 1–2.
4. Granule bin with suction pipe:  
Unscrew the suction pipe’s star knob. Pull out the suction pipe.
5. Remove the granule bin’s quick coupling ring.  
Note! A granule bin with suction pipe can be provided with a cover. Hold the cover while removing / installing the quick coupling ring.
6. Granulator with screen hole diameter .31–.39 in {8–10 mm}: Unscrew the granule bin’s star knob.
7. Remove the granule bin. Move the granule bin along the grooves in the screen box.
8. The granule bin is opened.

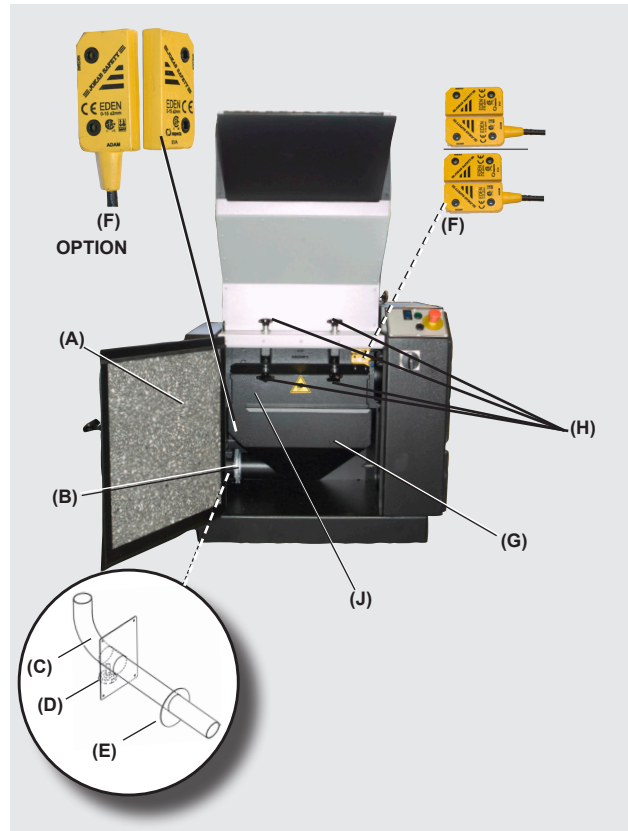

### Open the screen box

1. Read page 2:18 “Screen” and “Screen box”.
2. Open the granule bin. >Page 6:2 point 1–7.
3. Unscrew the screen box’s star knob. Note! Hold the screen box while opening / closing it, so it does not fall uncontrolled.
4. Fold the screen box down.
5. Remove the screen box.
6. Remove the screen.
7. The screen box is opened.

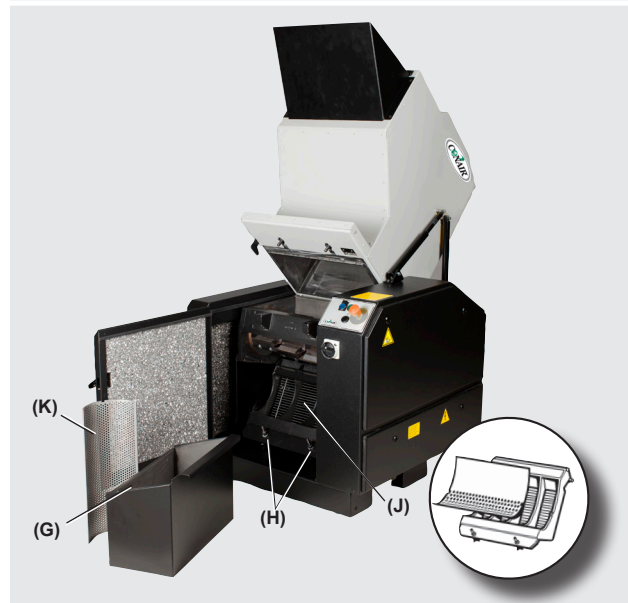

- (A) = Door, Enclosure  
 (B) = Quick coupling ring, Granule bin / Outlet  
 (C) = Suction pipe, Granule bin  
 (D) = Star knob, Suction pipe  
 (E) = Cover, Suction pipe / Granule bin  
 (F) = Safety sensor  
 (G) = Granule bin  
 (H) = Star knob  
 (J) = Screen box  
 (K) = Screen

## Open the granulator

### Open the hopper

1. Read page 6:1 “General rules, Open the granulator”.
2. Read page 2:17 “Hopper”.

#### 3. Open a light hopper:

- a) Unscrew the hopper’s star knob.
- b) Push the hopper upwards.

#### 3. Open a heavy hopper:

- a) Unscrew the hopper’s star knob.
- b) Start the granulator’s current supply.  
>Page 5:1 point 3–4 “Start the granulator”.
- c) Put the knob “Hopper, Close / Open” in position “Open”.
- d) At the same time (two hand operation), press the buttons “Operate 1” and “Operate 2”. Keep the buttons depressed until the jack has opened the hopper.
- e) Stop the granulator’s current supply.  
>Page 5:1 point 3–4 “Stop the granulator”.

4. The hopper is opened.

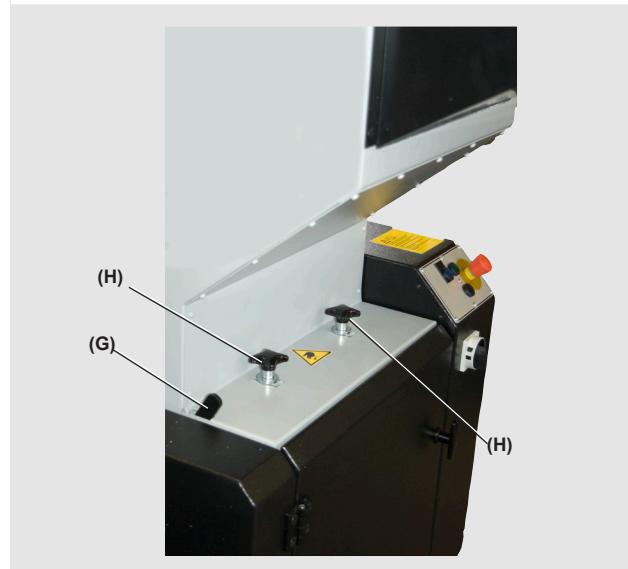
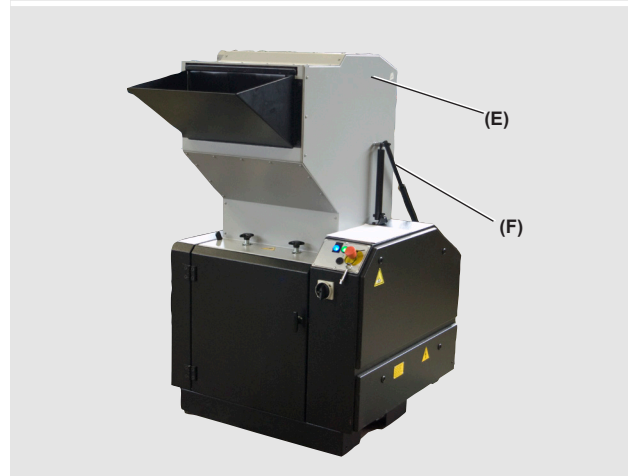
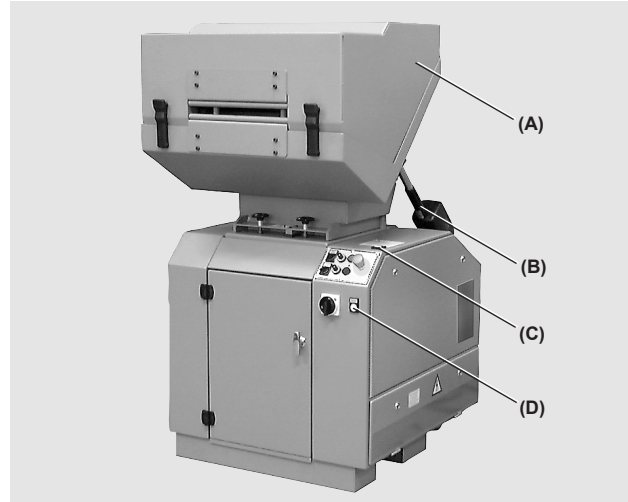

(A) = Heavy hopper  
 (B) = Hopper device, Jack  
 (C) = Button “Operate 1”  
 (D) = Button “Operate 2”

(E) = Light hopper  
 (F) = Hopper device, Gas spring  
 (G) = Tipping catch  
 (H) = Star knob, Hopper

## Close the granulator

### General rules, Close the granulator

1. Read page 1:4 “Safety rules, During service”.
2. Check that all surfaces which are going to touch are clean before closing.
3. Additional suffix -B (Band conveyor): After closing the granulator, put the band conveyor close to the granulator’s hopper / inlet.

### Close the hopper

1. Read page 6:4 “General rules, Close the granulator”.
2. Read page 2:17 “Hopper”.

#### 3. Close a light hopper:

- a) Pull the hopper down.
- b) Release the tipping catch.
- c) Tighten the hopper’s star knob.
- d) Check that the green light on the safety sensor is steady lit.

#### 3. Close a heavy hopper:

- a) Start the granulator’s current supply.  
>Page 5:1 point 3–4 “Start the granulator”.
- b) Put the knob “Hopper, Close / Open” in position “Close”.
- c) At the same time (two hand operation), press the buttons “Operate 1” and “Operate 2”. Keep the buttons depressed until the jack has closed the hopper.
- d) Tighten the hopper’s star knob.
- e) Stop the granulator’s current supply.  
>Page 5:1 point 3–4 “Stop the granulator”.
- f) Check that the green light on the safety sensor is steady lit.

4. The hopper is opened.

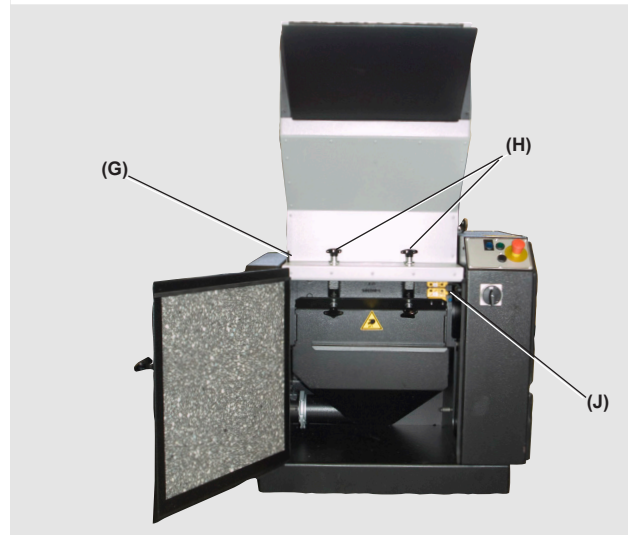
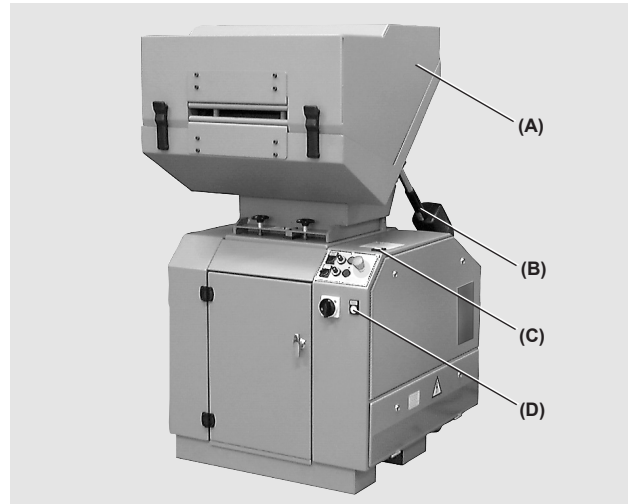

(A) = Heavy hopper  
 (B) = Hopper device, Jack  
 (C) = Button “Operate 1”  
 (D) = Button “Operate 2”  
 (E) = Light hopper

(F) = Hopper device, Gas spring  
 (G) = Tipping catch  
 (H) = Star knob, Hopper  
 (J) = Safety sensor

## Close the granulator

### Close the screen box

1. Read page 2:18 “Screen “ and “Screen box”.
2. Read page 2:19 “Star knob” and “Safety sensor”.
3. Read page 6:4 “General rules, Close the granulator”.
4. Install the screen. Note! A half perforated screen, a so called stitch reducing screen (option), must be installed with the perforated side facing forwards. Refer to figure on the right.
5. Install the screen box. Fold the screen box up.
6. Tighten the screen box’s star knob. Note! Hold the screen box while opening / closing it, so it does not fall uncontrolled.
7. The screen box is closed.
8. Check that the green light on the safety sensor is steady lit.

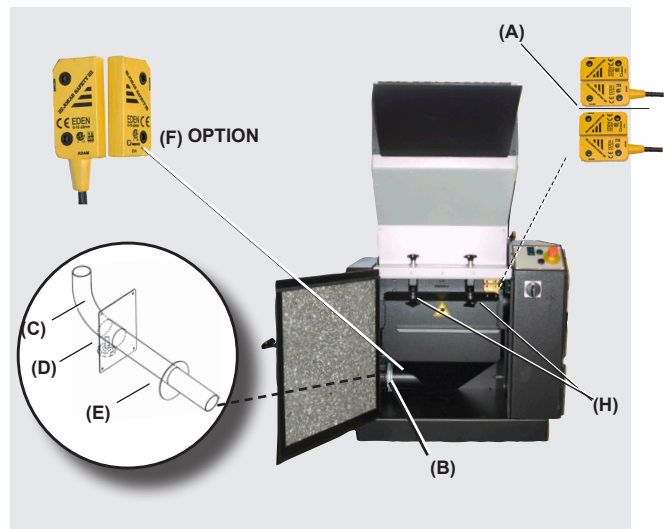

### Close the granule bin

1. Read page 2:18 “Granule bin”.
2. Close the screen box. >Page 6:5 point 1–8.
3. Install the granule bin. Move the granule bin along the grooves in the screen box.
4. Granulator with screen hole diameter .31–.39 in {8–10 mm}: Tighten the granule bin’s star knob. Check that the green light on the safety sensor is steady lit.
5. Granule bin with suction pipe:  
Install the suction pipe. Tighten the suction pipe’s star knob.
6. Install the granule bin’s quick coupling ring. Note! A granule bin with suction pipe can be provided with a cover. Hold the cover while removing / installing the quick coupling ring.
7. Close the enclosure’s door(s). >Page 6:1 point 1–2.
8. The granule bin is closed.

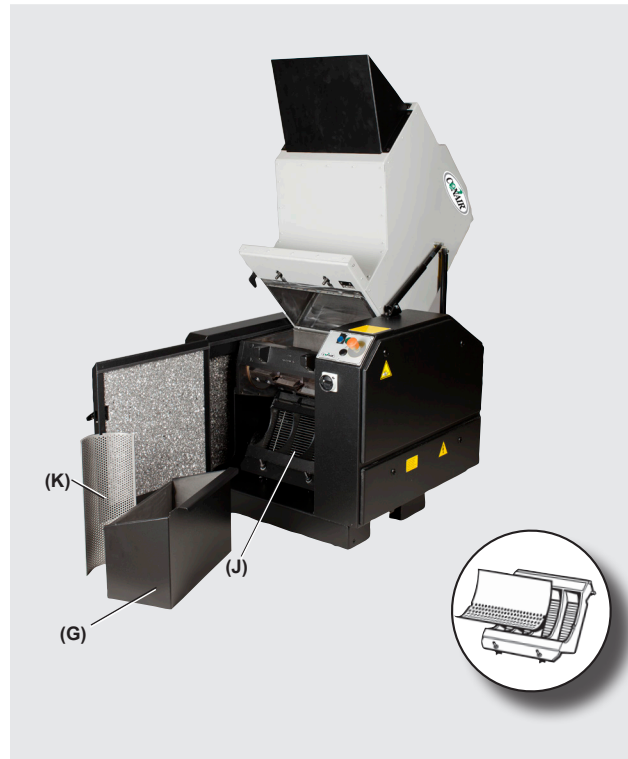

- (A) = Safety sensor, hopper and screen box  
 (B) = Quick coupling ring, Granule bin / Outlet  
 (C) = Suction pipe, Granule bin  
 (D) = Star knob, Suction pipe  
 (E) = Cover, Suction pipe / Granule bin  
 (F) = Safety sensor, Granule bin  
 (G) = Granule bin  
 (H) = Star knob, Screen box  
 (J) = Screen box  
 (K) = Screen

## Close the granulator

### Close the enclosure

1. Read page 6:4 “General rules, Close the granulator”.
2. Close the screen box. >Page 6:5.
3. Close the granule bin. >Page 6:5.
4. Close the enclosure’s door(s). Pull the enclosure’s handle.
5. Close the enclosure’s rear cover. Install the rear cover. Tighten the rear cover’s tightening screws.
6. The enclosure is closed.

### Close the transmission

1. Read page 6:4 “General rules, Close the granulator”.
2. Close the enclosure’s rear cover. >Page 6:6 point 5 “Close the enclosure”.
3. Install the transmission cover. Tighten the transmission cover’s tightening screws.
4. The transmission is closed.

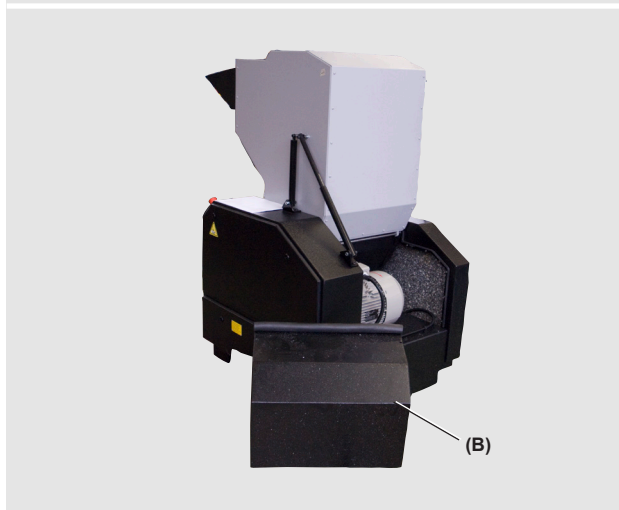

(A) = Door, Enclosure  
 (B) = Rear cover, Enclosure  
 (C) = Cover, Transmission

## General rules, Service



1. Read page 1:4 “Safety rules, During service”.
2. Check / maintain the machine in accordance with the service schedule.
3. Always sign inspections / service in a service report. Copy the original service report, sign the copy and save it in a separate service binder. >Page 8:1 “Service report”.

### Emergency stop(s)

1. Read page 7:1 “General rules, Service”.
2. Read page 2:20 “Emergency stop(s)”. Check the emergency stop(s):
  - a) Start the granulator. >Page 5:1.
  - b) Stop feeding material. Wait until all material have been fully granulated.
  - c) Press the emergency stop. Check that the granulator stops. If the granulator stops, the emergency stop can be reset and the granulator can be operated again.
  - d) **Danger!** If the granulator continues working, although the emergency stop has been pressed, the granulator must be stopped manually at once. >Page 5:1. There is a serious risk of personal injury! Contact the personnel responsible for the machine’s service and safety.



### Flap(s)

1. Read page 7:1 “General rules, Service”.
2. Read page 2:18 “Flap(s)”.
3. Pull the front and the rear stripes out.
4. Check the flap(s). Change as necessary. >Page 9:2 “Flap(s)”.
5. Re-install the opposite way.

### Service schedule

| Interval             | Done by           | Check  |
|----------------------|-------------------|--|
| Once every day       | Operator          | <ul style="list-style-type: none"> <li>• Emergency stop(s)</li> <li>• Flap(s)</li> </ul>                         |
| Once every week      | Trained personnel | <ul style="list-style-type: none"> <li>• Safety equipment</li> <li>• Electrical components</li> </ul>            |
| Once every month     | Trained personnel | <ul style="list-style-type: none"> <li>• Knife sharpness</li> <li>• Knife clearance</li> <li>• Screen</li> </ul> |
| Once every 6th month | Trained personnel | <ul style="list-style-type: none"> <li>• Drive belt(s)</li> <li>• Important tightening torques</li> </ul>        |

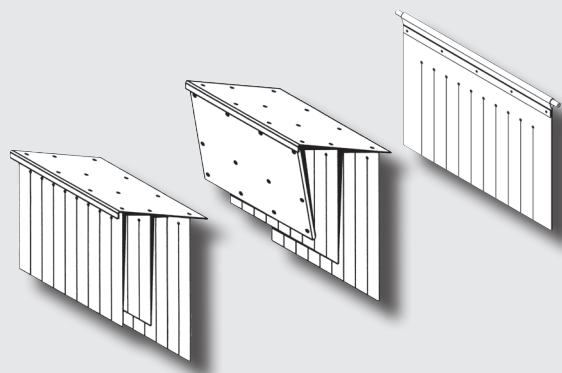
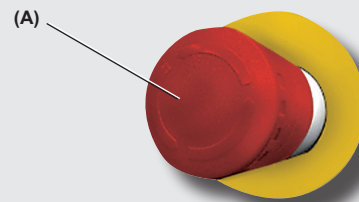

(A) = Emergency stop(s)  
(B) = Flap(s)

## Safety equipment

1. Read page 7:1 “General rules, Service”.
  2. Read page 2:16 “General rules, Safety equipment”. Check that all parts of the safety equipment are installed.
  3. Read page 2:19 “Safety sensor”. Check that the safety sensors are functioning. Check one safety sensor pair at the time.
    - a) Start the granulator. >Page 5:1.
    - b) Stop feeding material. Wait until all material has been fully granulated. While the hopper and screen box aren't opened the safety sensor's light should shine a steady green light, indicating that the sensors are working correctly. If the light is blinking the star knobs needs to be tighten to decrease the distance between the safety sensors.
    - c) Unscrew the two upper star knobs. When the light of the safety sensor starts blinking, the distance between the two sensors is on the edge of what's acceptable. When the light has gone out the distance between the safety sensors is too big and the granulator should stop.
    - d) Check that the granulator stops. If the granulator stops, the safety sensors are functioning and the granulator can be operated again.
-  **Danger!** If the granulator continues working, although the safety sensors have been separated from each other, the granulator must be stopped manually at once. >Page 5:1. There is a serious risk of personal injury! Contact the personnel responsible for the machine's service and safety.
- e) Repeat point c) but unscrew the lower star knobs instead of the upper star knobs.
  - f) Repeat point d).

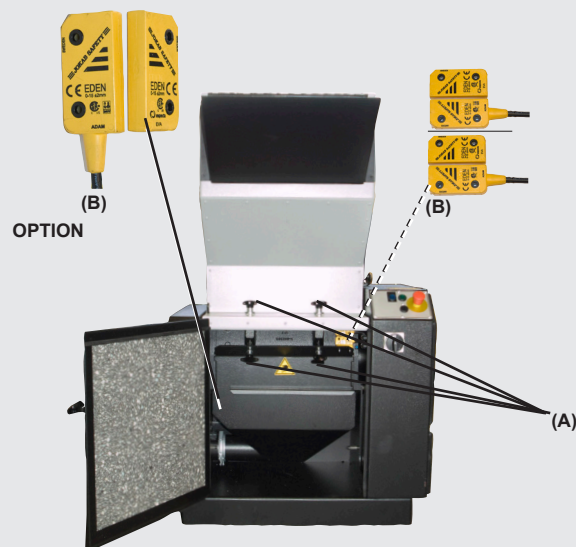
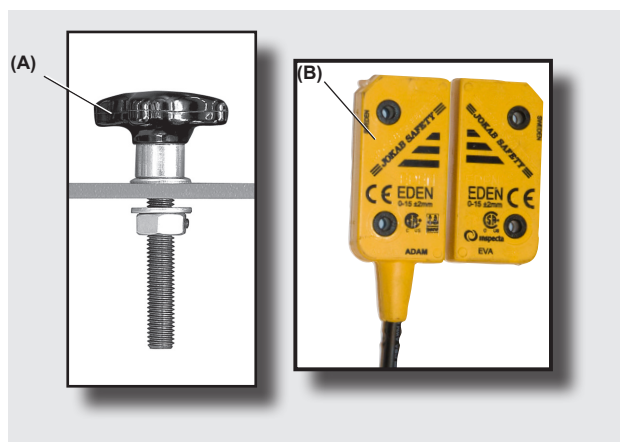

(A) = Star knob  
(B) = Safety sensor

## Electrical components

1. Read page 7:1 “General rules, Service”.
2. Read page 4:3 “General rules, Electrical connection”.
3. Check all the cables. If there are any damaged or loose cables, connectors or components, authorized personnel must be called at once to do repairs.

## Level switch

1. Read page 7:1 “General rules, Service”.
2. Read page 2:22 “Level switch”.
3. Open the granule bin. >Page 6:2.
4. Adjust the level switch’s sensitivity.

Level switch, Paddle type:



- a) Open the level switch top cover
  - b) Unscrew three of the five screws according to the picture to the right. Note that one of them holds the ground cable in place.
  - c) Change the position of the spring in the level switch, see picture to the right. Use nose pliers to change position.
  - d) Put the screws, ground cable and the cover back. Make sure the ground cable is attached as it was before.
5. Close the granule bin. >Page 6:5.

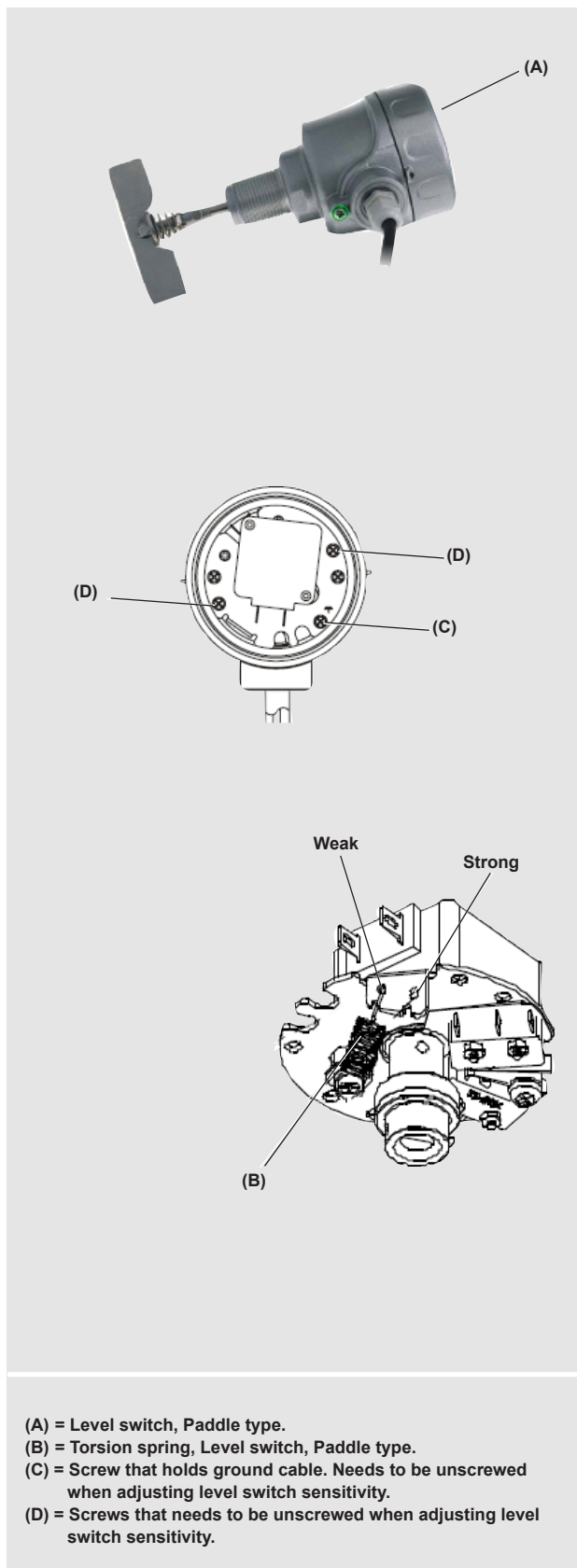

# Current relay

1. Read page 7:1 “General rules, Service”.
2. Read page 2:24-2:27 “Current relay”.
3. Set the wanted reaction time: I<sup>Δ</sup>Delay (T<sub>1</sub>).
4. Set the time delay during start up, OnDelay (T<sub>2</sub>), to 0 sec.
5. Check following points in the electrical circuit diagram:
  - Rated current.
  - Y/D-start or Direct-start. If the granulator is Y/D started and equipped with an ammeter, calculate as if granulator is direct started.
6. Calculate the limit value in Ampere “LVA”. Set I<sup>Δ</sup> (overcurrent detection value) to LVA-value or slightly lower.
7. Set the hysteresis (HA) to a value lower then the LVA-value. Around one tenth of the LVA-value.
8. Set the function settings to “Without memory”, “Excess current” and “NC Us=on” according to page 2:24-2:27.
9. Start the granulator. >Page 5:1.
10. Check that the current relay’s setting is satisfying, see page 2:25 and 2:27. Adjust as necessary.



### Example: Detection of overcurrent

- T<sub>1</sub> is set to 3 sec.
- Rated current is 15 A.
- The granulator is Y/D-started.
- LVA is calculated to 8.7 A.  
 $8.7 A = 15 / \sqrt{3}$
- HA is set to one tenth of LVA.  
HA is calculated to 0.87 A:  
 $0.87 A = 0.1 \cdot 8.7 = 8.7 / 10$
- The function setting is set to “Mem? No”, “Excess current” and “NC Us=on”.

The settings in the example means:

During operation, the relay will trip and stop the feed equipment if the granulator’s current consumption exceeds 8.7 A for over 3 seconds.

The function setting “Mem? No” enables the relay to restart the feed equipment when the granulator’s current consumption has sunk to  $8.7 - 0.87 = 7.83 A$ .

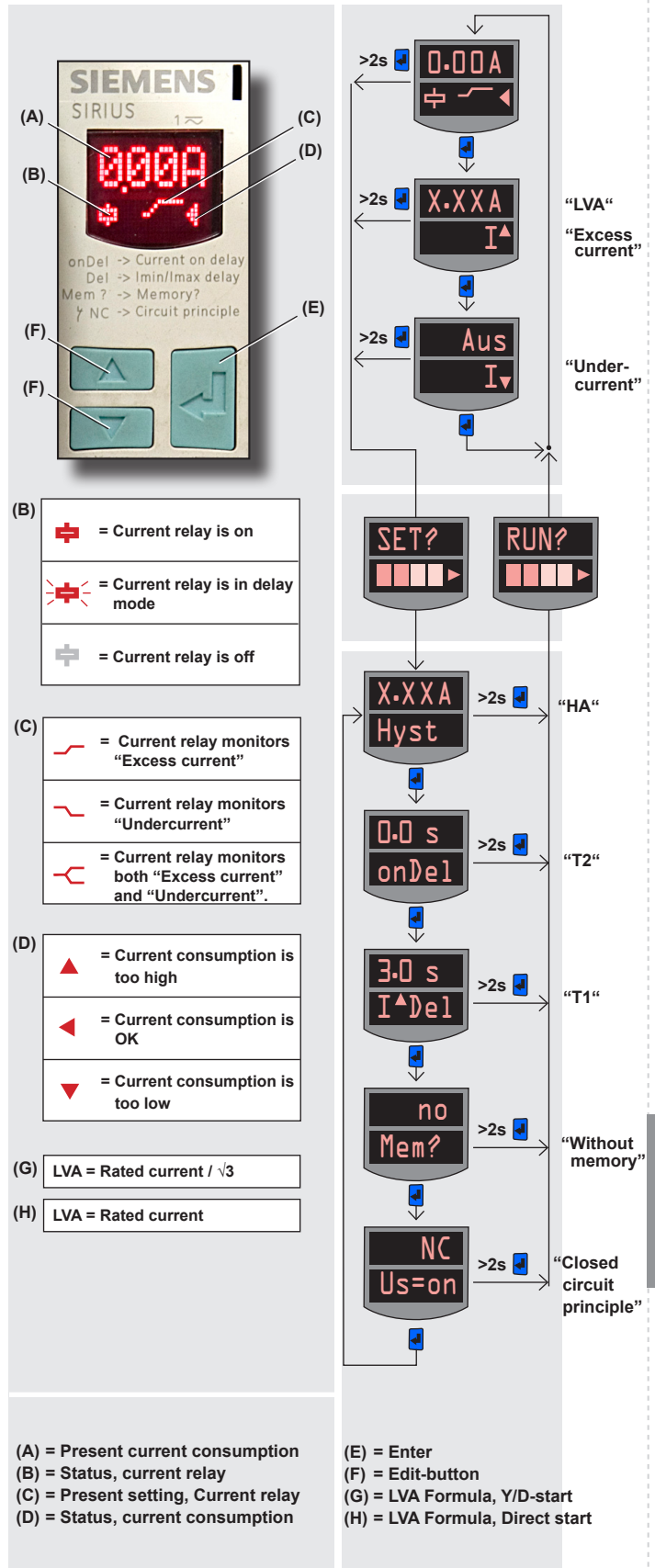

## Band conveyor

1. Read page 7:1 “General rules, Service”.
2. Read page 2:10 “Additional suffix -B”.
3. Check the band’s rotation direction.  
If the rotating direction is wrong:
  - a) Stop the granulator. >Page 5:1.
  - b) Read page 4:3 “General rules, Electrical connection”.
  - c) Switch over two incoming phases.
  - d) Start the granulator. >Page 5:1.
4. Check that the band runs straight.  
If the band runs obliquely:
  - a) Stop the band conveyor.
  - b) Open the covers at the band’s turn drum.
  - c) Adjust the band’s adjusting screws a 1/4 turn at a time.
  - d) Start the band conveyor. Let the band run for a few minutes. Check that the band runs straight.

If the band still runs obliquely, repeat point 4 a–d until the band runs straight.



Note! The band’s length has a tolerance of 1%. The adjusting screws’ tightening torque must never exceed 3.69 lbf·ft {5 N·m}.

5. Close the covers at the band’s turn drum.

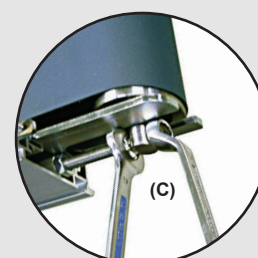
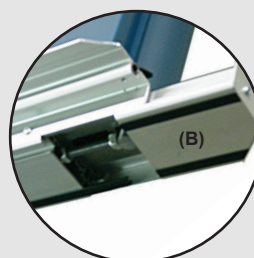
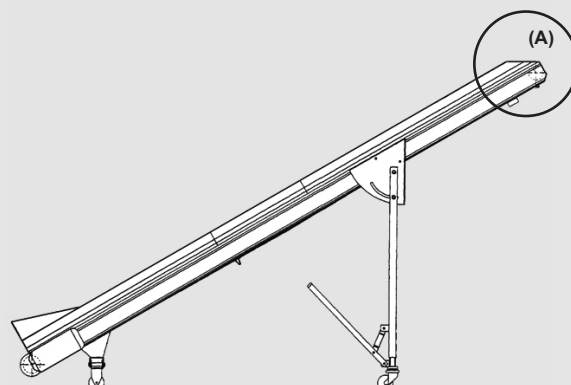
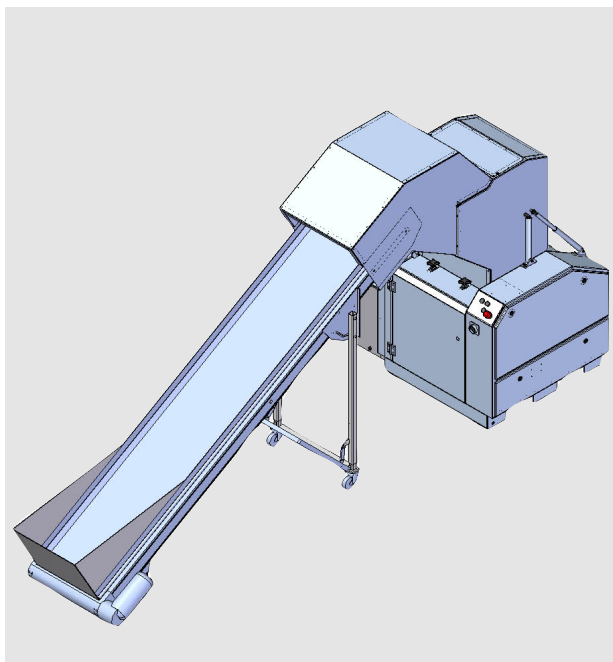

- (A) = Turn drum, Band conveyor  
 (B) = Cover, Turn drum  
 (C) = Adjusting nuts, Band conveyor

## Important tightening torques



Check the tightening torque of important machine parts 30 hours after installation and then regularly every 6 months. Respect specified tightening torques. Use a torque wrench.

1. The fixed knives' tightening screws.  
Tightening torque 29.50 lbf·ft {40 N·m}.
2. The rotating knives' tightening screws.  
Staggered rotor: Tightening torque 55.32 lbf·ft {75 N·m}.  
Open rotor: Tightening torque 162.26 lbf·ft {220 N·m}.
3. The motor's tightening screws.  
Tightening torque 29.50 lbf·ft {40 N·m}.

## Lubrication

All bearings in the granulator are lubricated for life and must not be re-greased.

## Storage

1. Treat all components that could rust with rust preventer for long-term rust protection.
2. Store the machine in a dry area with even temperature.
3. Rotate the rotor manually every 3 months.

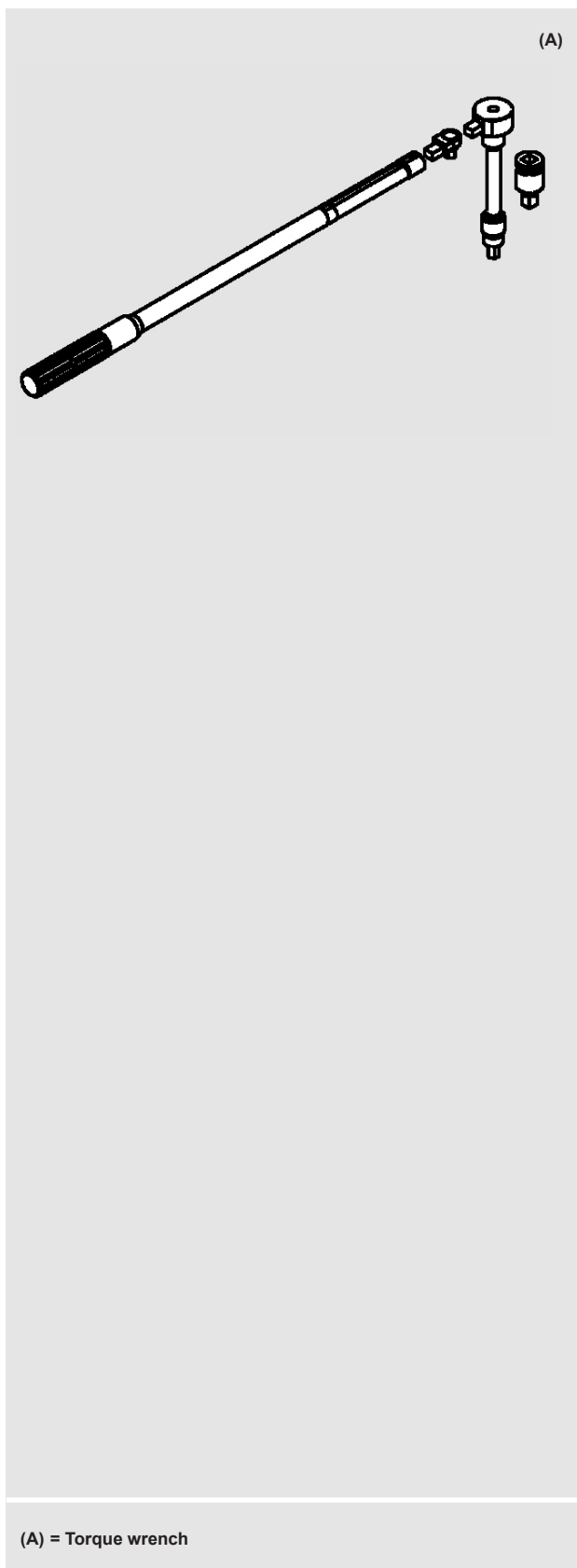

## Cleaning



### **When granulating material that generates dust:**

- a) Clean the granulator's parts once every day or at least once every week.
- b) Clean the bearing housing once every day.



### **In normal operation:**

- a) Clean the granulator's parts at colour change or at least once every 300 hours.
- b) Clean the bearing housing once every week.

1. Read page 7:1 "General rules, Service".
2. Open the granulator. >Page 6:1–6:3.
3. Clean the granulator parts. Use a vacuum cleaner. Clean following parts inside and outside: Hopper, Flap(s), Cutter housing, Screen, Screen box, Granule bin, Enclosure.



Important! Granulate and plastic residue can make the floor slippery.

4. Additional suffix -U (Blower): Clean the blower, outlet pipe and granule bin very carefully. Use a vacuum cleaner.



Note! When starting, remaining material in the blower, outlet pipe or granule bin can cause serious and irreparable damage to the blower.

5. Additional suffix -B (Band conveyor): Clean the band. Use a gentle detergent. Strong detergents can damage the band. Wipe clean with lint-free rags.

6. Clean the bearing housing. Remove the blue painted screws. Blow clean through the holes. Use compressed air and a blow gun. Rotate the rotor a few turns. Tighten the blue painted screws.



Important! Remaining material in the bearing housing can melt and cause serious or irreparable damage to the bearings.



Important! If the rotor is stuck, rotate the rotor in the reverse direction, if necessary tap carefully with a piece of wood. Never use any metal object when trying to release the rotor.



Important! If the hopper, cutter housing, screen box and/or granule bin are filled with compact, melt plastic residue, Conair's distributor or Conair's head office must be contacted for service.

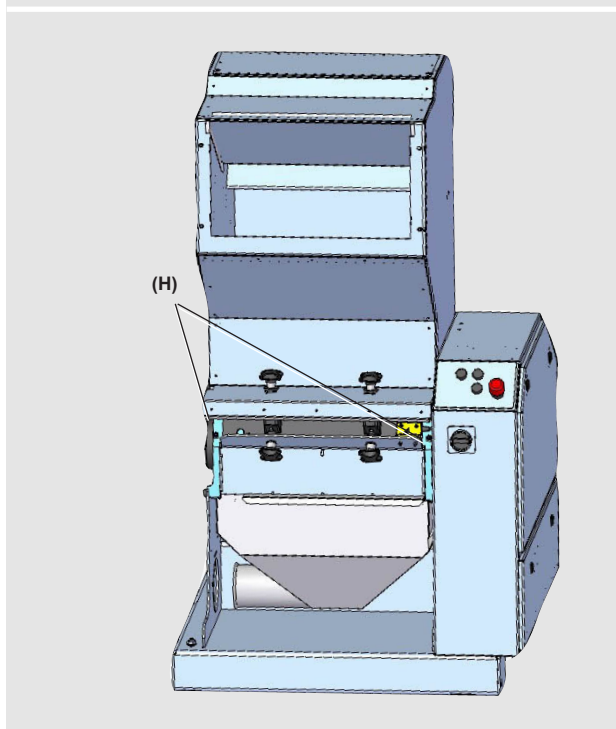
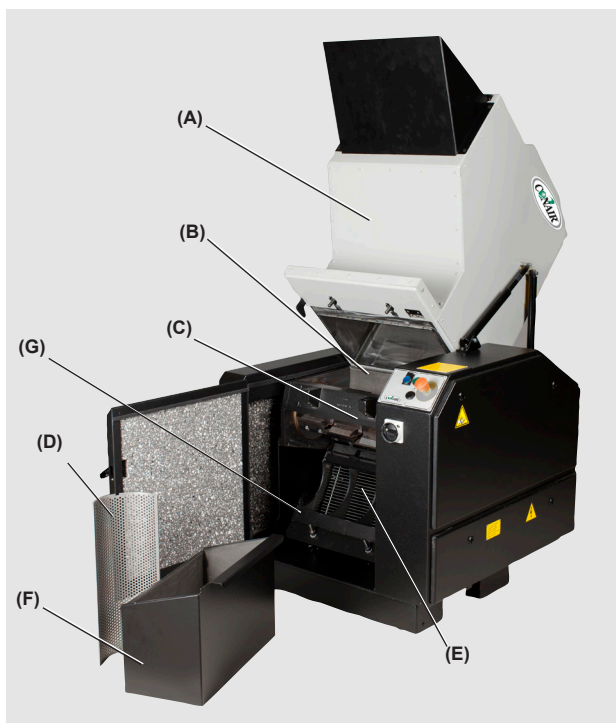

- (A) = Hopper
- (B) = Cutter housing
- (C) = Rotor
- (D) = Screen
- (E) = Screen box
- (F) = Granule bin
- (G) = Outlet pipe, Granule bin
- (H) = Blue screws, Bearing housing

## Knives

### General rules, Knives



1. Read page 7:1 “General rules, Service”.
2. Read page 2:12 “Rotor, Rotating knives”.
3. Read page 2:13 “Cutter housing, Fixed knives”.
4. Read page 2:14 “Grinding fixture”, “Knife clearance” and “Presetting fixture”.
5. Always lock the rotor’s position with a piece of wood while changing the knives.
6. All screws and nuts that are sealed with red paint, are permanently set and glued. These screws and nuts must under no circumstances be unscrewed, tightened or changed.
7. Knife sharpness and knife clearance must be checked regularly. The granulator must never be used with blunt knives. Blunt knives cause abnormal wear and damage the granulator. The rotating knives to a staggered rotor are of disposable type and must be discarded and replaced as necessary. The rotating knives to an open rotor must be regrinded or discarded as necessary. The fixed knives are of disposable type and must be discarded and replaced as necessary. Note! For information regarding blunt knives and knife clearance, read page 7:14 “Knife clearance”. Note! The fixed knives are reversible. This means that the fixed knife has two cutting edges and can be reversed once before discarding is necessary.
8. Every second time tightening screws are unscrewed they must be replaced with new ones.
9. When replacing knives, washers, support rules and tightening screws only use original spare parts supplied by Conair.
10. Respect specified tightening torques. Use a torque wrench.
11. Respect specified measures.

If any of the above listed rules are left unattended, Conair’s responsibility under the Machinery Directive ceases to apply.

In event of any questions, please contact Conair’s local distributor or Conair’s head office.



## Remove the rotating knives

### Granulator with open rotor

1. Read page 7:8 “General rules, Knives”
2. Open the hopper. >Page 6:3.
3. Remove the granule bin. >Page 6:2.
4. Remove the screen box. >Page 6:2.
5. Remove the knives on one knife row at the time.
6. Rotate the rotor to an appropriate position. Lock the rotor’s position with a piece of wood.
7. Unscrew the rotating knife’s tightening screws. Hold the knife while unscrewing the tightening screws.
8. Remove the rotating knife and the washers.
9. Repeat point 6–9 until all rotating knives have been removed.

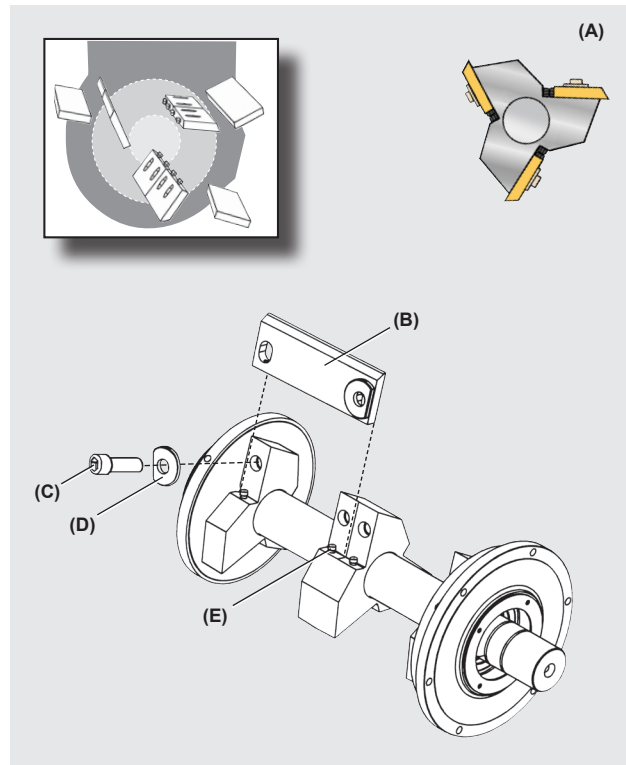

### Granulator with staggered rotor

1. Read page 7:8 “General rules, Knives”
2. Open the hopper. >Page 6:3.
3. Remove the granule bin. >Page 6:2.
4. Remove the screen box. >Page 6:2.
5. Remove the knives on one knife row at the time.
6. Rotate the rotor to an appropriate position. Lock the rotor’s position with a piece of wood.
7. Unscrew the rotating knife’s tightening screws. Hold the knife and the support rule while unscrewing the tightening screws.
8. Remove the rotating knife, the support rule and the washers.
9. Repeat point 6–9 until all rotating knives have been removed.

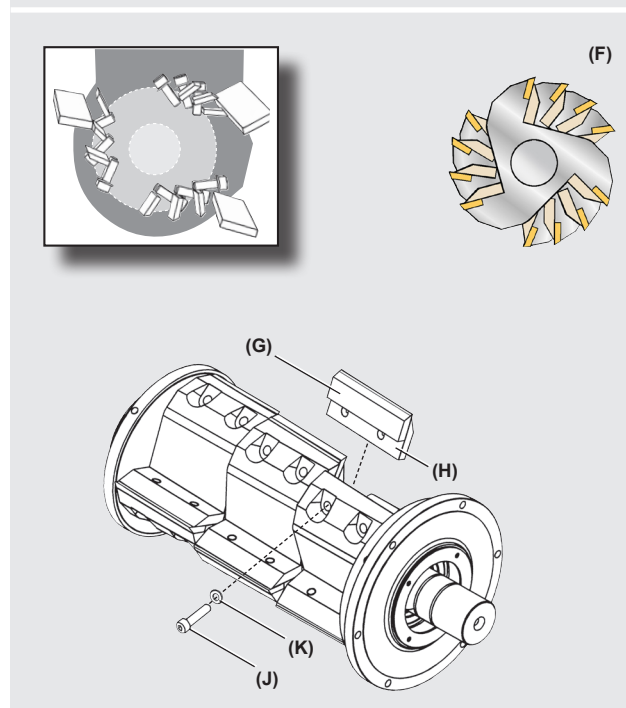

- |                                    |   |
|------------------------------------|---|
| (A) = Open rotor                   | (G) = Rotating knife, Staggered rotor   |
| (B) = Rotating knife, Open rotor   | (H) = Support rule, Open rotor          |
| (C) = Tightening screw, Open rotor | (J) = Tightening screw, Staggered rotor |
| (D) = Washer, Open rotor           | (K) = Washer, Staggered rotor           |
| (E) = Grub screw, Open rotor       |   |
| (F) = Staggered rotor              |   |

## Install the rotating knives

### Granulator with open rotor

1. Read page 7:8 “General rules, Knives”
2. Remove the rotating knives. >Page 7:9.
3. Preset the rotating knives. >Page 7:17.
4. Install one knife at the time.
5. Rotate the rotor to an appropriate position. Lock the rotor’s position with a piece of wood.
6. Check that the knife seat is clean.
7. Install the rotating knife, the washers and the tightening screws. Note! The washers are to be installed so that they fully cover the knife’s screw holes.
8. Press the knife firmly to the bottom of the knife seat. Tighten the knife’s tightening screws. Tightening torque 162.26 lbf·ft {220 N·m}.



Note! Use a rubber head mallet and give the knife a firm punch every now and then meanwhile the tightening torque gradually is increased. This is to ensure that the knife is installed in the very bottom of the knife seat.



Note! The grub screws in the bottom of the knife seat are permanently set and glued. These screws must under no circumstances be unscrewed, tightened or changed.

9. Check the knife clearance. >Page 7:14.
10. Repeat point 5–10 until all rotating knives have been installed.

### Granulator with staggered rotor

1. Read page 7:8 “General rules, Knives”
2. Remove the rotating knives. >Page 7:9.
3. Install one knife at the time.
4. Rotate the rotor to an appropriate position. Lock the rotor’s position with a piece of wood.
5. Check that the knife seat is clean.
6. Install the rotating knife, the support rule, the washers and the tightening screws.
7. Press the knife firmly to the bottom of the knife seat. Tighten the knife’s tightening screws. Tightening torque 55.32 lbf·ft {75 N·m}.



Note! Use a rubber head mallet and give the knife a firm punch every now and then meanwhile the tightening torque gradually is increased. This is to ensure that the knife is installed in the very bottom of the knife seat.

8. Check the knife clearance. >Page 7:14.
9. Repeat point 4–9 until all rotating knives have been installed.

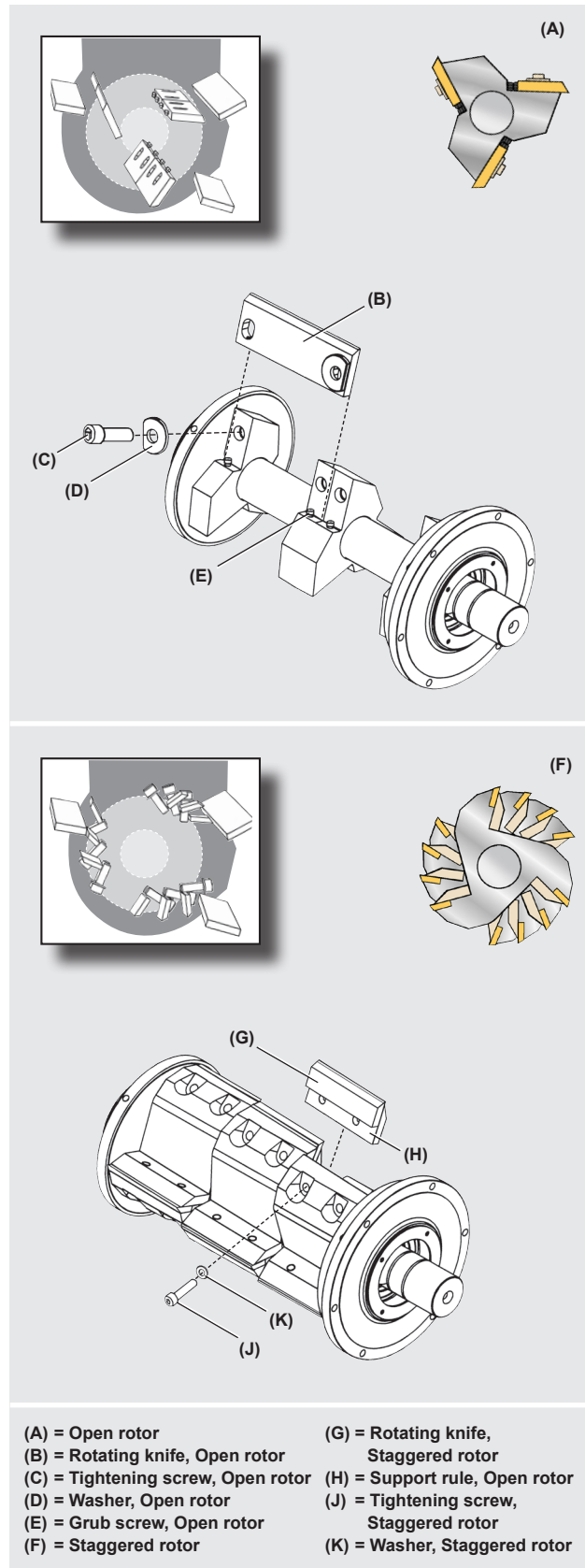

## Knives

### Remove the fixed knife 2nd

1. Read page 7:8 “General rules, Knives”.
2. Open the hopper. >Page 6:3.
3. Remove the granule bin. >Page 6:2.
4. Remove the screen box. >Page 6:2.
5. Rotate the rotor to an appropriate position. Lock the rotor’s position with a piece of wood.
6. Remove the fixed knife 2nd. Refer to figure on the right. Unscrew the support rule’s tightening screws. Hold the knife and the support rule while unscrewing the tightening screws.



Note! Do not tighten / unscrew any screws sealed with red paint. These screws are permanently set and glued!

7. NCF-824: Repeat point 5–7 until both fixed knives 2nd have been removed.

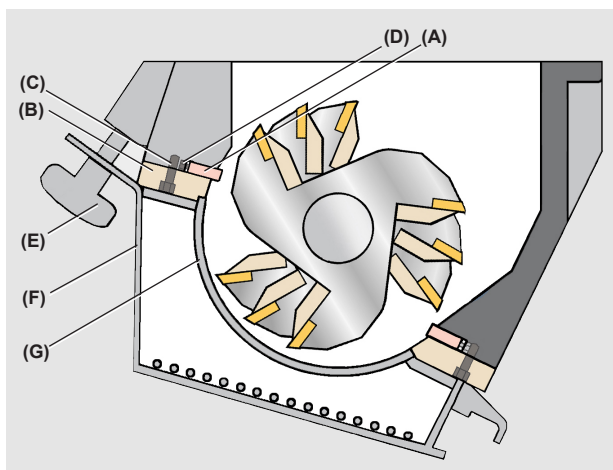

### Install the fixed knife 2nd

1. Read page 7:8 “General rules, Knives”.
2. Remove the fixed knife / fixed knives.
3. Rotate the rotor to an appropriate position. Lock the rotor’s position with a piece of wood.
4. Check that the knife seat is clean.
5. Install the fixed knife, the support rule and the tightening screws. Refer to figure on the right.
6. Press the knife firmly to the bottom of the knife seat.
7. Tighten the knife’s tightening screws. Tightening torque 29.50 lbf·ft {40 Nm}.



Note! Use a rubber head mallet and give the knife a firm punch every now and then meanwhile the tightening torque gradually is increased. This is to ensure that the knife is installed in the very bottom of the knife seat.

8. Check the knife clearance. >Page 7:14.
9. NCF-824: Repeat point 3–9 until both fixed knives 2nd have been installed.

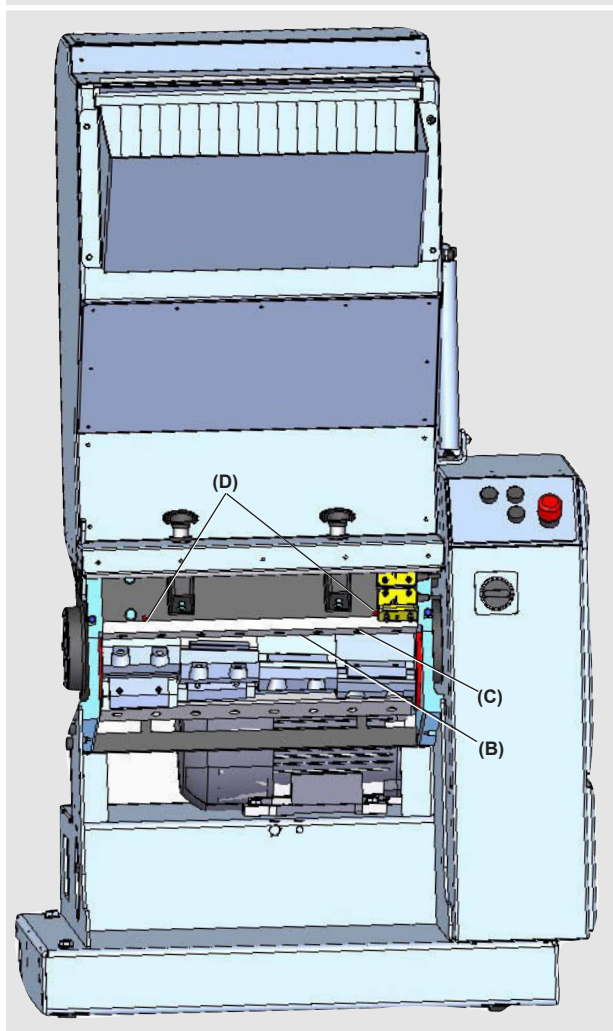

- (A) = Front fixed knife 2nd
- (B) = Support rule, Front fixed knife 2nd
- (C) = Tightening screws, Front fixed knife 2nd
- (D) = Red painted grub screws
- (E) = Star knob, Screen box
- (F) = Screen box
- (G) = Screen

## Knives

### Remove the fixed knife 1st

1. Read page 7:8 “General rules, Knives”.
2. Open the hopper. >Page 6:3.
3. Remove the granule bin. >Page 6:2.
4. Remove the screen box. >Page 6:2.
5. Rotate the rotor to an appropriate position. Lock the rotor’s position with a piece of wood.
6. Remove the fixed knife 1st. Refer to figure on the right. Unscrew the support rule’s tightening screws. Hold the knife and the support rule while unscrewing the tightening screws.



Note! Do not tighten / unscrew any screws sealed with red paint. These screws are permanently set and glued!

7. NCF-824: Repeat point 5–7 until both fixed knives 1st have been removed.

### Install the fixed knife 1st

1. Read page 7:8 “General rules, Knives”.
2. Remove the fixed knife / fixed knives.
3. Rotate the rotor to an appropriate position. Lock the rotor’s position with a piece of wood.
4. Check that the knife seat is clean.
5. Install the fixed knife, the support rule and the tightening screws. Refer to figure on the right.
6. Press the knife firmly to the bottom of the knife seat.
7. Tighten the knife’s tightening screws. Tightening torque 29.50 lbf·ft {40 Nm}.



Note! Use a rubber head mallet and give the knife a firm punch every now and then meanwhile the tightening torque gradually is increased. This is to ensure that the knife is installed in the very bottom of the knife seat.

8. Check the knife clearance. >Page 7:14.
9. NCF-824: Repeat point 3–9 until both fixed knives 1st have been installed.

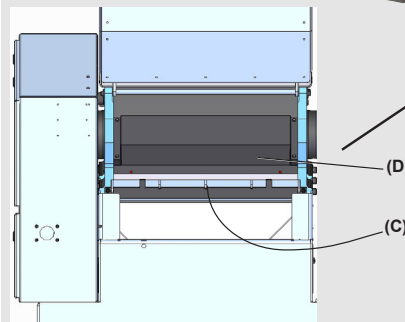
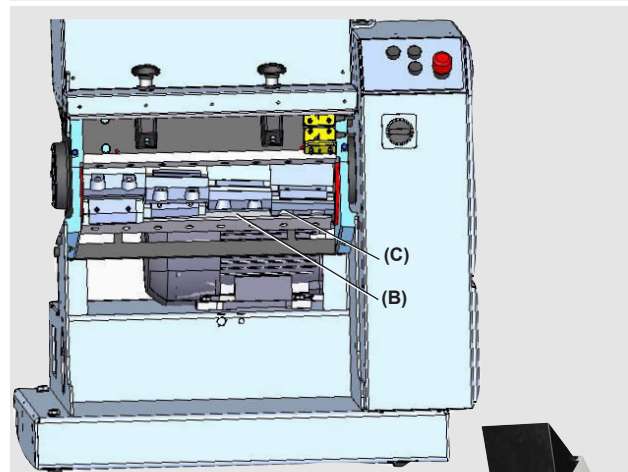
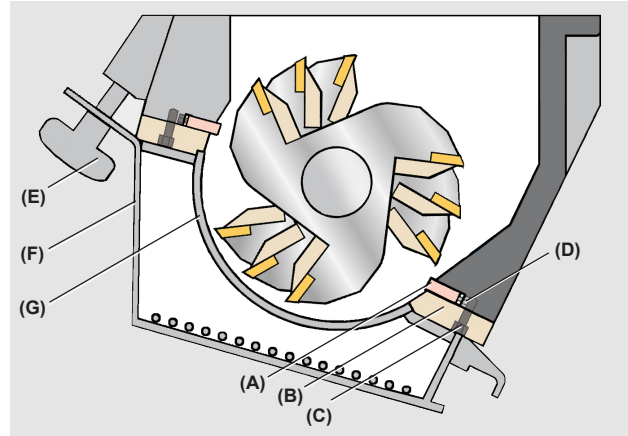

- |   |                  |
|---|------------------|
| (A) = Rear fixed knife 1st                    | (E) = Star knob, |
| (B) = Support rule, Rear fixed knife 1st      | Screen box       |
| (C) = Tightening screws, Rear fixed knife 1st | (F) = Screen box |
| (D) = Red painted grub screws                 | (G) = Screen     |

## Knives

### General rules, Fixed knife 3rd



Information! Fixed knife 3rd is optional.  
>Read page 2:13 “Fixed knives”.



Note! The tightening screws to fixed knife 3rd are tightened / unscrewed from the back side of the granulator.



Granulator with enclosure: Before tightening / unscrewing tightening screws to fixed knife 3rd, the enclosure's rear cover must be removed.

### Remove the fixed knife 3rd

1. Read page 7:8 “General rules, Knives”.
2. Open the hopper. >Page 6:3.
3. Granulator with enclosure: Remove the enclosure's rear cover. >Page 6:1.
4. Remove the granule bin. >Page 6:2.
5. Remove the screen box. >Page 6:2.
6. Rotate the rotor to an appropriate position. Lock the rotor's position with a piece of wood.
7. Remove the fixed knife 3rd. Refer to figure on the right. Unscrew the support rule's tightening screws. Hold the knife and the support rule while unscrewing the tightening screws.



Note! Do not tighten / unscrew any screws sealed with red paint. These screws are permanently set and glued!

8. NCF-824: Repeat point 6–8 until both fixed knives 3rd have been removed.

### Install the fixed knife 3rd

1. Read page 7:8 “General rules, Knives”.
2. Remove the fixed knife / fixed knives.
3. Rotate the rotor to an appropriate position. Lock the rotor's position with a piece of wood.
4. Check that the knife seat is clean.
5. Install the fixed knife, the support rule and the tightening screws. Refer to figure on the right.
6. Press the knife firmly to the bottom of the knife seat.
7. Tighten the knife's tightening screws. Tightening torque 29.50 lbf·ft {40 Nm}.



Note! Use a rubber head mallet and give the knife a firm punch every now and then meanwhile the tightening torque gradually is increased. This is to ensure that the knife is installed in the very bottom of the knife seat.

8. Check the knife clearance. >Page 7:14.
9. NCF-824: Repeat point 3–9 until both fixed knives 3rd have been installed.

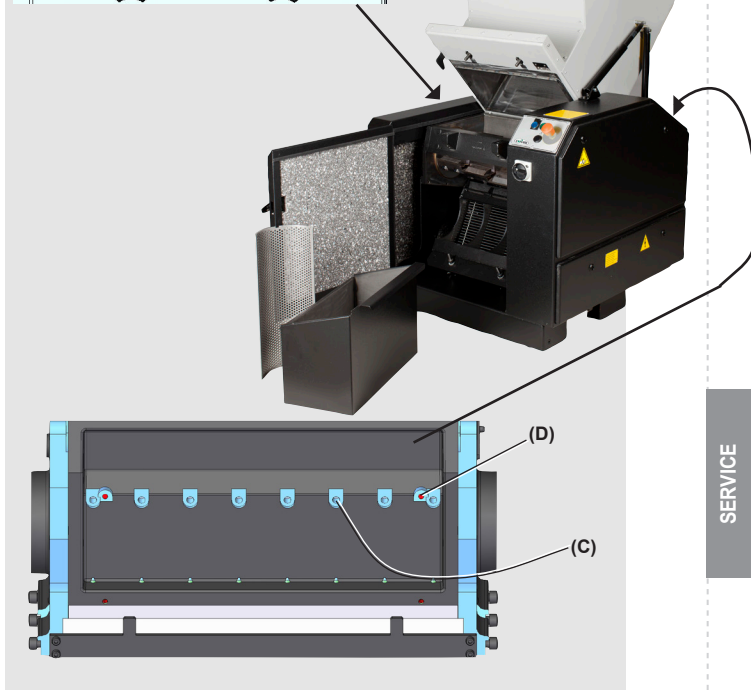
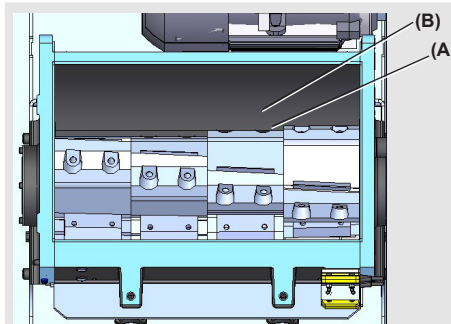
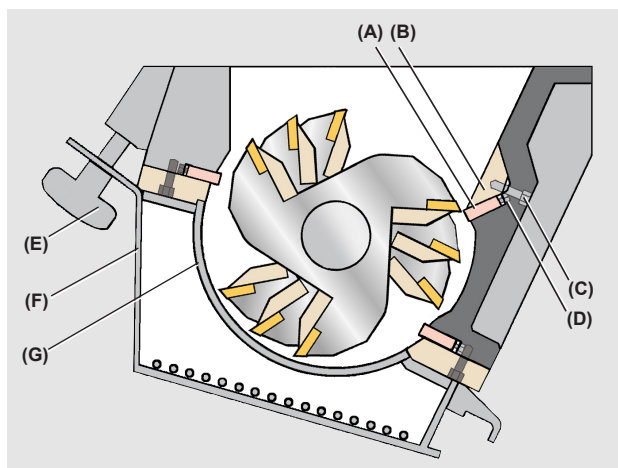

- (A) = Rear fixed knife 3rd
- (B) = Support rule, Rear fixed knife 3rd
- (C) = Tightening screws, Rear fixed knife 3rd
- (D) = Red painted grub screws
- (E) = Star knob, Screen box
- (F) = Screen box
- (G) = Screen

## Knives

### Knife clearance

1. Read page 2:14 “Knife clearance”.
2. Read page 7:8 “General rules, Knives”.
3. Open the hopper. >Page 6:3.
4. Remove the granule bin. >Page 6:2.
5. Remove the screen box. >Page 6:2.
6. Check the knife clearance. Check the knife clearance at one knife seat at the time.
  - a) Rotate the rotor to an appropriate position. Lock the rotor’s position with a piece of wood.
  - b) Put a feeler gauge between the fixed knife and the rotating knife. Put the feeler gauge alternately to the right, to the left and in the middle. Correct knife clearance is .006 – .01 in {0.15 – 0.25 mm}.
7. Repeat point 6 above, until the knife clearance has been checked at all knife seats.



- Note! If the knife clearance is wrong:
- a) Remove the knife. >Page 7:9–7:13.
  - b) Re-install the knife. >Page 7:9–7:12.
  - d) Re-check the knife clearance. >Page 7:14.

8. Close the hopper. >Page 6:4.
9. Close the screen box. >Page 6:5.
10. Close the granule bin. >Page 6:5.
11. Close the enclosure. >Page 6:6.

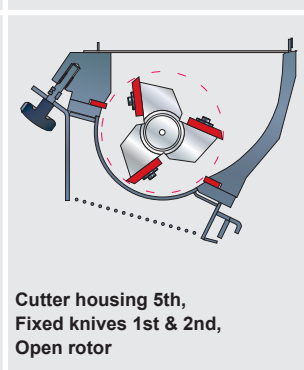
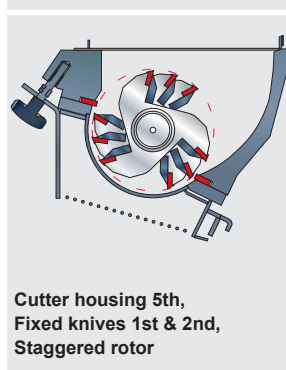
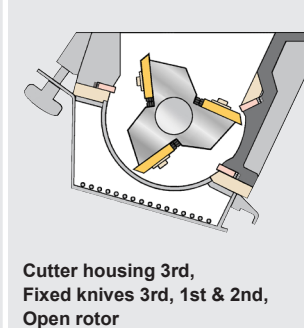
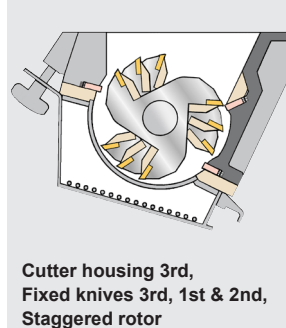
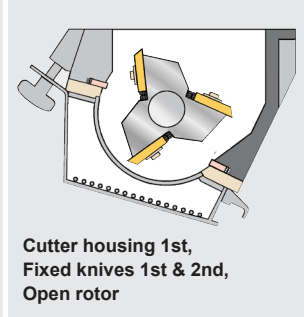
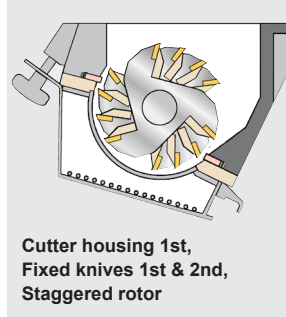
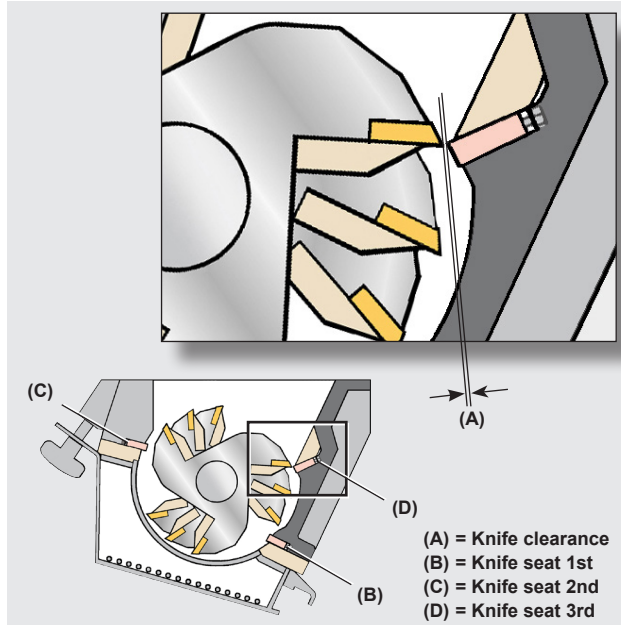

| Knife clearance                           |                                       |   |                                       |
|---|---------------------------------------|---|---------------------------------------|
| Correct knife clearance standard in. {mm} | Correct knife clearance film in. {mm} | Maximal knife clearance standard in. {mm} | Maximal knife clearance film in. {mm} |
| .006-.01<br>{0.15-0.25}                   | .004-.01<br>{0.1-0.25}                | .012<br>{0.30}                            | .012<br>{0.30}                        |



Note! Correct knife clearance and maximal knife clearance depends on type and form of the material to grind. The values above are guidelines.

## Knives

### General rules, Grind the knives



Note! It is only possible to grind the open rotor's rotating knives.

1. Read page 7:8 "General rules, Knives".
2. Always begin grinding the worst and most blunt knife.
3. Grind the knives with accurate precision. It is very important that the relief angle and the cutting angle becomes correct. Respect specified measures.
4. Always cool the knives during grinding. Grind slowly. Make sure that no heat is developed. Knives that are overheated when grinded, loose their hardness, strength and durability. Knives that have been burned or quenched blue, are irreparable and must be discarded.
5. A surface grinder with magnetic table and a grinding fixture ensures that the cutting angles and the relief angles becomes correct.

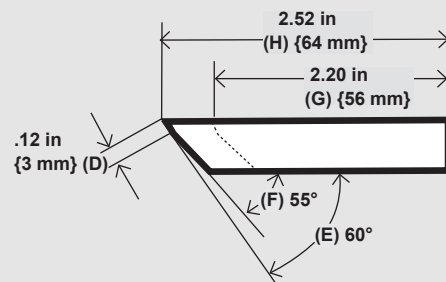
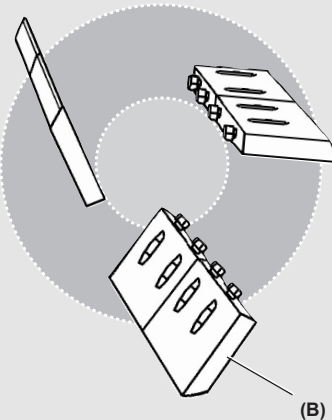
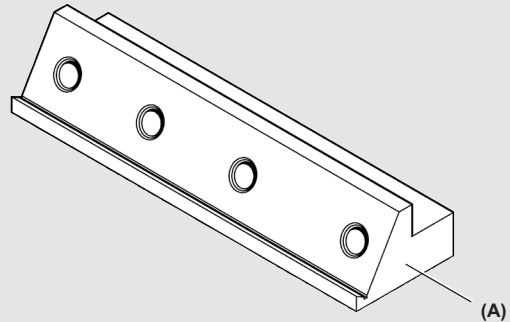

- (A) = Grinding fixture  
 (C) = Rotating knife, Open rotor  
 (D) = Relief surface, Rotating knife  
 (E) = First relief angle, Rotating knife  
 (F) = Second relief angle, Rotating knife  
 (G) = Minimum length, grinded rotating knife  
 (H) = Length, new rotating knife

## Knives

### Grind the rotating knives

1. Read page 7:15 “General rules, Grind the knives”.
2. Install the rotating knife in the grinding fixture. Install the grinding fixture’s distance. Tighten the knife with the grinding fixture’s tightening screws and spherical washers. Refer to the upper figure on the right.
3. Grind the rotating knife’s second relief angle. Use a surface grinder. A correct second relief angle on the rotating knife is  $55^\circ$ . Grind until all irregularities have disappeared.
4. Remove the knife but keep the settings on the surface grinder.



Note! All rotating knives must be grinded equally to maintain the rotor balance. All rotating knives must have the same measure and weight (within a gramme).

5. Repeat point 2–5 until all rotating knives’ second relief angles have been grinded.
6. Install the rotating knife in the grinding fixture. Remove the grinding fixture’s distance. Tighten the knife with the grinding fixture’s tightening screws and spherical washers. Refer to the middle figure on the right.
7. Grind the rotating knife’s cutting edge and first relief angle. Use a surface grinder. A correct first relief angle on the rotating knife is  $60^\circ$ . Grind until the first relief surface becomes .12 in {3 mm}.
8. Remove the knife but keep the settings on the surface grinder.
9. Measure the knife’s length after grinding.



Note! If the rotating knife’s length is less than 2.20 in {56 mm}, the old rotating knife must be discarded and replaced by a new rotating knife.

10. Repeat point 6–10 until all rotating knives’ cutting edges have been grinded.

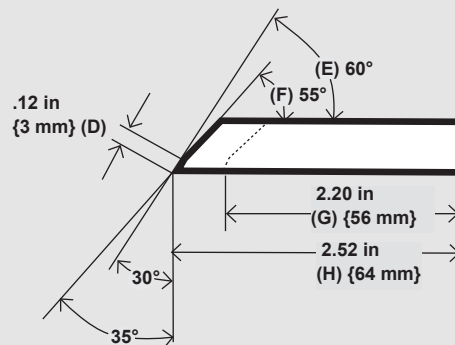
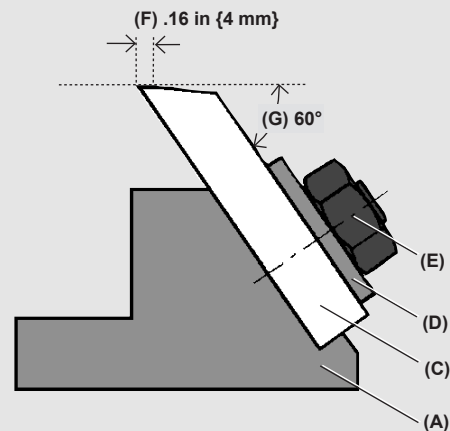
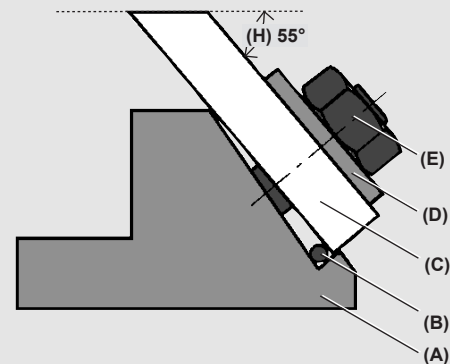

- (A) = Grinding fixture
- (B) = Distance, Grinding fixture
- (C) = Rotating knife
- (D) = Washer, Grinding fixture
- (E) = Tightening screw, Grinding fixture
- (F) = Relief surface, Rotating knife
- (G) = First relief angle, Rotating knife
- (H) = Second relief angle, Rotating knife
- (J) = Minimum length, grinded rotating knife
- (K) = Length, new rotating knife

## Knives

### General rules, Preset the knives



Note! It is only possible to preset the open rotor's rotating knives.

1. Read page 7:8 "General rules, Knives"
2. Only preset new or newly grinded knives.  
>Page 7:15 "Grind the rotating knives".
3. The adjusting screws can be adjusted in a presetting fixture. >Page 2:14 "Presetting fixture".

### Preset the rotating knives

1. Read page 7:17 "General rules, Preset the knives".
2. Tighten the knife's adjusting screws.
3. Install the knife in the presetting fixture. Refer to figure on the right.
4. Adjust the knife's adjusting screws. Tighten / Unscrew until the feeler gauge begins to bind.
5. Gently remove the feeler gauge and the knife.
6. Repeat point 3–6 until all rotating knives have been preset.

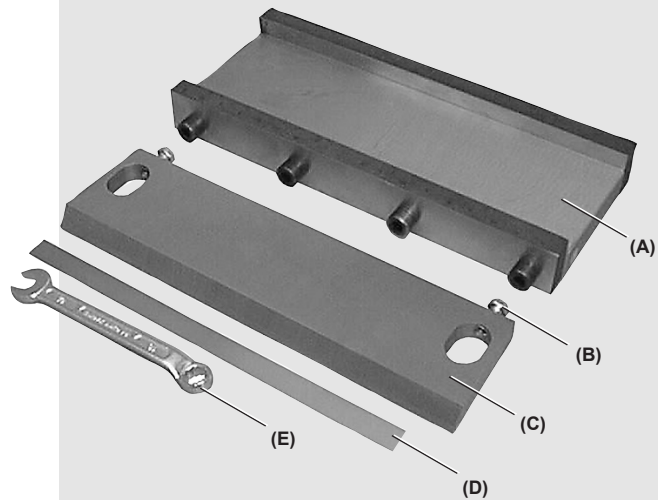
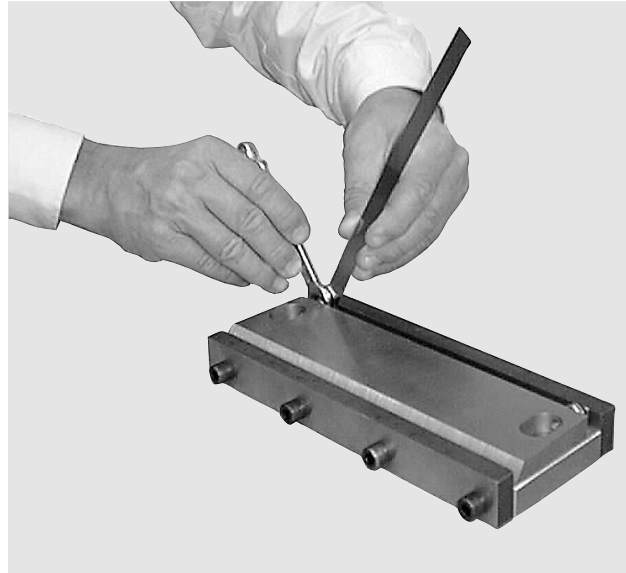

- (A) = Presetting fixture  
 (B) = Adjusting screw, Rotating knife  
 (C) = Rotating knife, Open rotor  
 (D) = Feeler gauge  
 (E) = Tool

## Drive belt(s)

### General rules, Drive belt(s)

1. Read page 7:1 “General rules, Service”.
2. Read page 2:15 “Transmission”.
3. Open the transmission. >Page 6:1.

### Check the drive belt(s)

1. Read page 7:18 “General rules, Drive belt(s)”.
2. Check the condition of the drive belt(s). Rotate the rotor pulley a few turns. Check that the drive belt(s) is/are intact and does/do not have any cracks.
3. Lock the rotor’s position with a piece of wood.
4. Check the belt tension. Check one drive belt at the time:
  - a) Load the drive belt in the middle between the rotor pulley and the motor pulley. Load the drive belt with the force specified in the belt tension table on page 7:18.
  - b) Measure the deflection depth. Correct deflection depth is .20 in {5 mm}.
6. Adjust the belt tension / replace drive belt(s) as necessary. >Page 7:19.
7. Close the transmission. >Page 6:6.

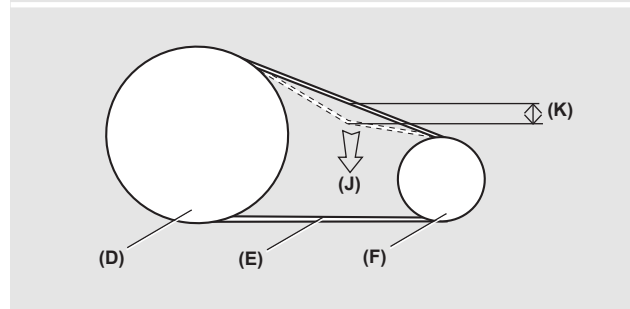
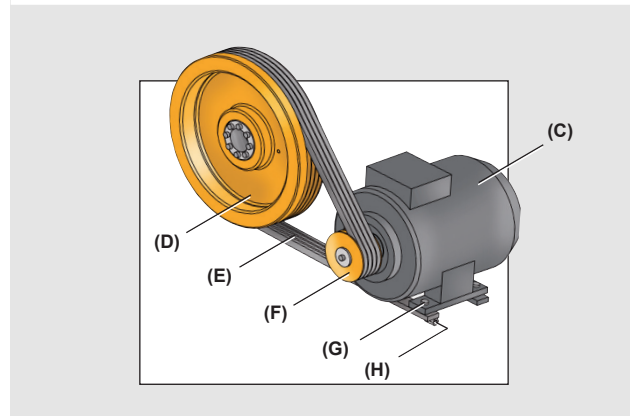
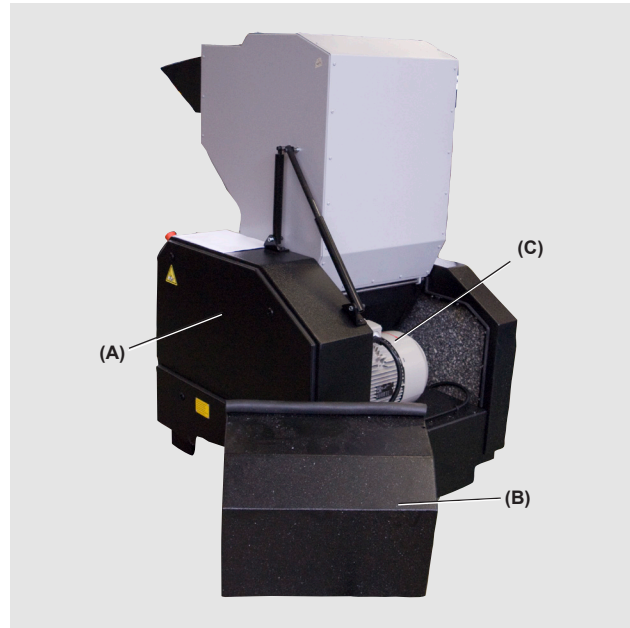

- (A) = Cover, Transmission
- (B) = Rear cover
- (C) = Motor
- (D) = Rotor pulley
- (E) = Drive belt(s)
- (F) = Motor pulley
- (G) = Tightening screws, Motor
- (H) = Adjusting screws, Belt tension
- (J) = Deflection force
- (K) = Deflection depth



| BELT TENSION TABLE | 4.0 kW          |                 | 5.5 kW          |                 |
|--------------------|-----------------|-----------------|-----------------|-----------------|
|                    | New drive belt  | Old drive belt  | New drive belt  | Old drive belt  |
| Deflection depth   | .20 in {5 mm}   | .20 in {5 mm}   | .20 in {5 mm}   | .20 in {5 mm}   |
| Deflection force   | 4.50 lbf {20 N} | 4.50 lbf {20 N} | 4.50 lbf {20 N} | 4.50 lbf {20 N} |

  

|                  | 7.5 kW          |                 | 11.0 kW         |                 |
|------------------|-----------------|-----------------|-----------------|-----------------|
|                  | New drive belt  | Old drive belt  | New drive belt  | Old drive belt  |
| Deflection depth | .20 in 5 mm     | .20 in 5 mm     | .20 in 5 mm     | .20 in 5 mm     |
| Deflection force | 4.50 lbf {20 N} | 4.50 lbf {20 N} | 6.07 lbf {27 N} | 6.07 lbf {27 N} |

## Drive belt(s)

### Adjust the belt tension

1. Read page 7:18 “General rules, Drive belt(s)”.
2. Check the drive belt(s). >Page 7:18.
3. Unscrew the motor’s tightening screws.
4. Adjust the belt tension. Tighten / unscrew the front and the rear adjusting screw.

 Note! Tighten the rear adjusting screw with the same number of turns which the front adjusting screw is unscrewed and vice versa. This is to ensure that the motor still will be parallel with the rotor.

5. Check that the rotor pulley and the motor pulley are in line (tolerance .02 in {0.5 mm}). Check that the motor and the rotor are parallel. Adjust the adjusting screws as necessary.
6. Tighten the motor’s tightening screws. Tightening torque 29.50 lbf·ft {40 N·m}.
7. Check the belt tension. >Page 7:18 “Check the drive belt(s)” point 4.
8. Close the transmission. >Page 6:6.

 Note! When drive belts have been adjusted they must be re-checked after 20 hours of operation.

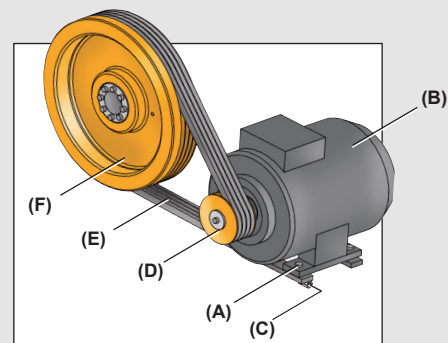
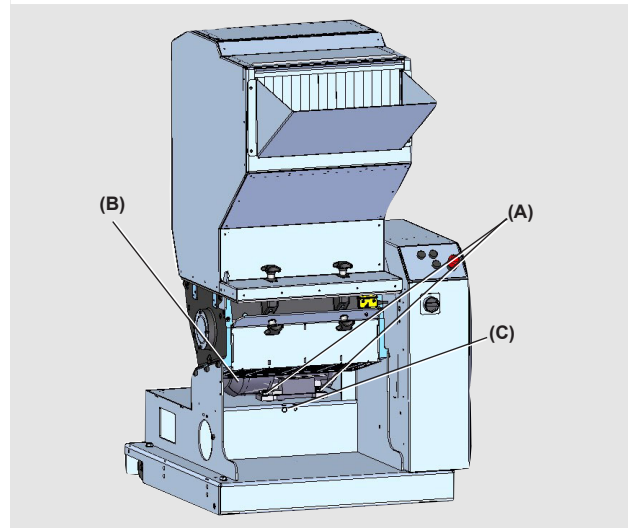
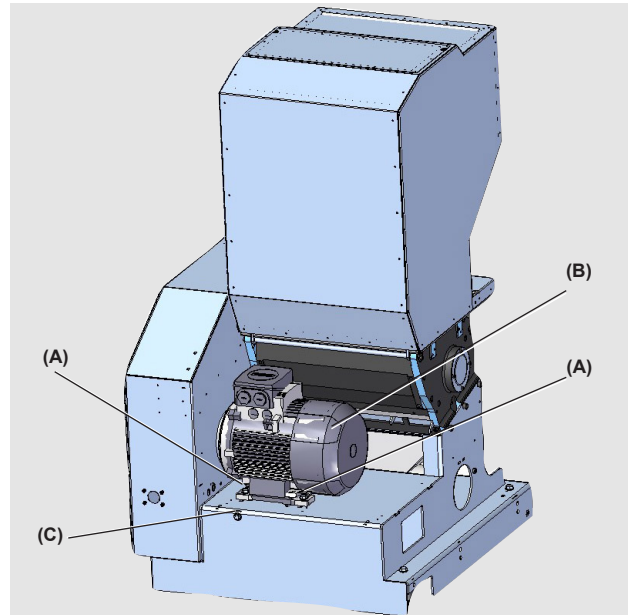

- (A) = Tightening screws, Motor  
 (B) = Motor  
 (C) = Adjusting screws, Belt tension  
 (D) = Motor pulley  
 (E) = Drive belt(s)  
 (F) = Rotor pulley

## Fault tracing

| Fault  | Probable cause   | Actions taken   |
|--|--|---|
| The granulator or any optional equipment does not start or stops unexpectedly. | The emergency stop is activated.   | 1. Reset the emergency stop(s). >Page 5:1.  |
|  | The granulator / the optional equipment is/are not connected to the mains.   | 1. Connect the granulator to the mains. >Page 4:3.<br>2. Connect the mains plug on the band conveyor. (Band conveyor = option).   |
|  | The main switch is in position "0".  | 1. Put the main switch in position "1". >Page 5:1.  |
|  | Screen, screen box, granule bin, hopper, enclosure and/or optional equipment are not properly closed.  | 1. Close the granulator. >Page 6:4–6:6.<br>2. Check that all safety sensors and star knobs are properly installed. >Page 7:2 "Safety equipment".  |
|  | The granulator's overload protection has tripped since the granulator has been overloaded.<br><br>or<br><br>Band conveyor (option): The band conveyor's overload protection has tripped since the band has got stuck or the granulator has been overloaded.<br><br>or<br><br>Blower (option): The blower's overload protection has tripped since the blower has been overloaded. | 1. Reset the overload protection. >Page 2:21 "Overload protection".<br><br>Before restart:<br>2. Clean the granulator. >Page 7:7<br>3. Check the drive belt(s). Adjust the belt tension / replace drive belt(s) as necessary. >Page 7:18–7:19.<br>4. Check the knife sharpness and the knife clearance. >Page 7:14. |
|  | The level switch (option) has stopped the granulator / the optional equipment.<br><br>or<br><br>The level switch's mains plug is disconnected.   | 1. Check the level switch. >Page 7:3.<br>2. Connect the mains plug on the level switch.   |
|  | The current relay has stopped the granulator / the optional equipment.   | 1. Check the current relay. >Page 7:4.  |
| The rotor still rotates even if the hopper is opened.                          | The drive belt(s) is/are worn or the belt tension is wrong.<br><br>or<br><br>The safety equipment is not functioning.  | 1. Check the drive belt(s). Adjust the belt tension / replace drive belt(s) as necessary. >Page 7:18–7:19.<br>2. Check the safety sensors. >Page 7:2 "Safety equipment".  |
|  | The granulator or any optional equipment does not start after normal fault tracing.  | 1. Lock the main switch in position "0".<br>2. Press the emergency stop(s).<br>3. Contact the personnel responsible for the machine's service and safety.<br>4. In event of any questions, please contact Conair's local distributor or Conair's head office.   |





### Service actions, Once every week

|            |         |            |  |   |
|------------|---------|------------|--|---|
| Week ..... | 20..... | Sign:..... | <input type="checkbox"/> Safety equipment, Approved. | <input type="checkbox"/> Electrical components, Approved. |
|            |         |            | <input type="checkbox"/> Bearing housing, Cleaned.   |   |
| Week ..... | 20..... | Sign:..... | <input type="checkbox"/> Safety equipment, Approved. | <input type="checkbox"/> Electrical components, Approved. |
|            |         |            | <input type="checkbox"/> Bearing housing, Cleaned    |   |
| Week ..... | 20..... | Sign:..... | <input type="checkbox"/> Safety equipment, Approved. | <input type="checkbox"/> Electrical components, Approved. |
|            |         |            | <input type="checkbox"/> Bearing housing, Cleaned    |   |
| Week ..... | 20..... | Sign:..... | <input type="checkbox"/> Safety equipment, Approved. | <input type="checkbox"/> Electrical components, Approved. |
|            |         |            | <input type="checkbox"/> Bearing housing, Cleaned    |   |
| Week ..... | 20..... | Sign:..... | <input type="checkbox"/> Safety equipment, Approved. | <input type="checkbox"/> Electrical components, Approved. |
|            |         |            | <input type="checkbox"/> Bearing housing, Cleaned    |   |
| Week ..... | 20..... | Sign:..... | <input type="checkbox"/> Safety equipment, Approved. | <input type="checkbox"/> Electrical components, Approved. |
|            |         |            | <input type="checkbox"/> Bearing housing, Cleaned    |   |
| Week ..... | 20..... | Sign:..... | <input type="checkbox"/> Safety equipment, Approved. | <input type="checkbox"/> Electrical components, Approved. |
|            |         |            | <input type="checkbox"/> Bearing housing, Cleaned    |   |
| Week ..... | 20..... | Sign:..... | <input type="checkbox"/> Safety equipment, Approved. | <input type="checkbox"/> Electrical components, Approved. |
|            |         |            | <input type="checkbox"/> Bearing housing, Cleaned    |   |
| Week ..... | 20..... | Sign:..... | <input type="checkbox"/> Safety equipment, Approved. | <input type="checkbox"/> Electrical components, Approved. |
|            |         |            | <input type="checkbox"/> Bearing housing, Cleaned    |   |
| Week ..... | 20..... | Sign:..... | <input type="checkbox"/> Safety equipment, Approved. | <input type="checkbox"/> Electrical components, Approved. |
|            |         |            | <input type="checkbox"/> Bearing housing, Cleaned    |   |
| Week ..... | 20..... | Sign:..... | <input type="checkbox"/> Safety equipment, Approved. | <input type="checkbox"/> Electrical components, Approved. |
|            |         |            | <input type="checkbox"/> Bearing housing, Cleaned    |   |
| Week ..... | 20..... | Sign:..... | <input type="checkbox"/> Safety equipment, Approved. | <input type="checkbox"/> Electrical components, Approved. |
|            |         |            | <input type="checkbox"/> Bearing housing, Cleaned    |   |
| Week ..... | 20..... | Sign:..... | <input type="checkbox"/> Safety equipment, Approved. | <input type="checkbox"/> Electrical components, Approved. |
|            |         |            | <input type="checkbox"/> Bearing housing, Cleaned    |   |
| Week ..... | 20..... | Sign:..... | <input type="checkbox"/> Safety equipment, Approved. | <input type="checkbox"/> Electrical components, Approved. |
|            |         |            | <input type="checkbox"/> Bearing housing, Cleaned    |   |



### Service actions, Once every month

Month ..... 20 ..... Sign:.....

**Rotating knife:**  Existing knives, Approved.  Knives and screws, Replaced.  Washers/Support rules, Replaced.

**Fixed knife:**  Existing knives, Approved.  Knives and screws, Replaced.  Support rules, Replaced.

**Screen:**  Existing Screen, Approved.  Screen, Replaced.  **Other remarks:**.....

Month ..... 20 ..... Sign:.....

**Rotating knife:**  Existing knives, Approved.  Knives and screws, Replaced.  Washers/Support rules, Replaced.

**Fixed knife:**  Existing knives, Approved.  Knives and screws, Replaced.  Support rules, Replaced.

**Screen:**  Existing Screen, Approved.  Screen, Replaced.  **Other remarks:**.....

Month ..... 20 ..... Sign:.....

**Rotating knife:**  Existing knives, Approved.  Knives and screws, Replaced.  Washers/Support rules, Replaced.

**Fixed knife:**  Existing knives, Approved.  Knives and screws, Replaced.  Support rules, Replaced.

**Screen:**  Existing Screen, Approved.  Screen, Replaced.  **Other remarks:**.....

Month ..... 20 ..... Sign:.....

**Rotating knife:**  Existing knives, Approved.  Knives and screws, Replaced.  Washers/Support rules, Replaced.

**Fixed knife:**  Existing knives, Approved.  Knives and screws, Replaced.  Support rules, Replaced.

**Screen:**  Existing Screen, Approved.  Screen, Replaced.  **Other remarks:**.....

Month ..... 20 ..... Sign:.....

**Rotating knife:**  Existing knives, Approved.  Knives and screws, Replaced.  Washers/Support rules, Replaced.

**Fixed knife:**  Existing knives, Approved.  Knives and screws, Replaced.  Support rules, Replaced.

**Screen:**  Existing Screen, Approved.  Screen, Replaced.  **Other remarks:**.....

Month ..... 20 ..... Sign:.....

**Rotating knife:**  Existing knives, Approved.  Knives and screws, Replaced.  Washers/Support rules, Replaced.

**Fixed knife:**  Existing knives, Approved.  Knives and screws, Replaced.  Support rules, Replaced.

**Screen:**  Existing Screen, Approved.  Screen, Replaced.  **Other remarks:**.....

### Service actions, Once every 6th month

Date ..... / ..... 20 ..... Sign:.....

**Drive belt(s)**  Drive belt(s) / Belt tension, Approved.  Belt tension, Adjusted.  Drive belt(s), Replaced.

**Important tightening torques:**  Approved  Adjusted: .....



### Other remarks

Date ..... / ..... 20 ..... Sign:.....  
 Other remarks:.....  
 .....

Date ..... / ..... 20 ..... Sign:.....  
 Other remarks:.....  
 .....

Date ..... / ..... 20 ..... Sign:.....  
 Other remarks:.....  
 .....

Date ..... / ..... 20 ..... Sign:.....  
 Other remarks:.....  
 .....

Date ..... / ..... 20 ..... Sign:.....  
 Other remarks:.....  
 .....

Date ..... / ..... 20 ..... Sign:.....  
 Other remarks:.....  
 .....

Date ..... / ..... 20 ..... Sign:.....  
 Other remarks:.....  
 .....

Date ..... / ..... 20 ..... Sign:.....  
 Other remarks:.....  
 .....

Date ..... / ..... 20 ..... Sign:.....  
 Other remarks:.....  
 .....

Date ..... / ..... 20 ..... Sign:.....  
 Other remarks:.....  
 .....

Date ..... / ..... 20 ..... Sign:.....  
 Other remarks:.....  
 .....

REPORT

## General rules, Spare parts



Note! When replacing machinery parts, only use original spare parts supplied by Conair. Spare parts orders should be sent to Conair’s local distributor. The following must be specified when spare parts are ordered:

- Serial number according to the machine’s type plate.
- Machine type according to the machine’s type plate.
- Manufacturing year.
- GB-detail, Specification, Article No and Q (Quantity) according to this spare part catalogue.

The performance of your supplied machine may vary from the standard machines described in this instruction manual. In event of any questions, please contact Conair’s local distributor or Conair’s head office.

### Overview

|                                   |           |
|-----------------------------------|-----------|
| Flap(s) .....                     | 9:2       |
| Funnel, Feed tray, Inlet .....    | 9:4–9:5   |
| Hopper.....                       | 9:6–9:7   |
| Hopper device .....               | 9:8–9:9   |
| Safety .....                      | 9:10      |
| Cutter housing .....              | 9:12–9:14 |
| Staggered rotor.....              | 9:15      |
| Open rotor .....                  | 9:16      |
| Knives for a staggered rotor..... | 9:17      |
| Knives for an open rotor .....    | 9:18      |
| Screen.....                       | 9:19      |
| Screen box.....                   | 9:20      |
| Granule bin, Outlet pipe.....     | 9:20      |
| Blower.....                       | 9:21      |
| Transmission .....                | 9:22      |
| Enclosure, Transmission .....     | 9:23      |
| Enclosure.....                    | 9:24      |
| Body.....                         | 9:26      |
| Options.....                      | 9:27      |



### Designations in the spare part catalogue

| P   | SE     | DE       | FR    | GB-DETAIL | SPECIFICATION          | Art No    | Q  | M   | V   |
|-----|--------|----------|-------|-----------|------------------------|-----------|----|-----|-----|
| (A) | KUTTER | ROTOR    | ROTOR | ROTOR     |                        | MF0060102 | 1  | 120 | 3BL |
| 1   | SKRUV  | SCHRAUBE | VIS   | SCREW     | SHS MC6S 5X14          | 838151    | 5  | 60  |     |
|     |        |          |       |           | SHS MC6S 5X14 HARDENED | 832257*   | 5  | 60  |     |
|     |        |          |       |           | SHS MC6S 6X20          | 834521    | 10 | 90  |     |
|     |        |          |       |           | SHS MC6S 6X20 HARDENED | 834522*   | 10 | 90  |     |
| 2   | MUTTER | MUTTER   | ÉCROU | NUT       |                        | 9-40213   | 9  | XX  | -S  |

P = Position number      Art No = Article number      Q = Quantity      M = Model number      V = Variant

If anything has been specified in the M “Model No” column, the item only applies to that model No.

If anything has been specified in the V “Variant” column, the item only applies to that machinery variant.

# Flap(s)

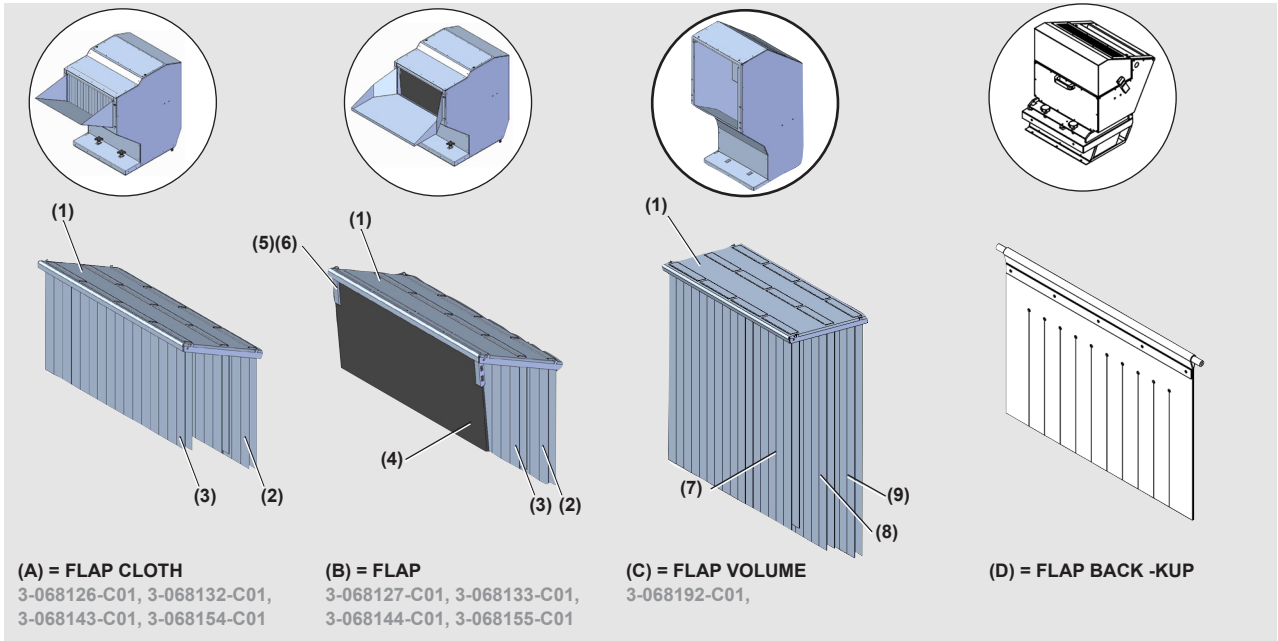

| P   | SE           | FR    | DE      | GB - DETAIL       | SPECIFICATION | ART NO    | Q        | M   | V          |     |
|-----|--------------|-------|---------|-------------------|---------------|-----------|----------|-----|------------|-----|
| (A) | KLAFF VÄV    | VOLET | KLAPPEN | FLAP CLOTH        | COMPLETE SET  | MF0068132 | 1        | 810 | -KU CLOTH  |     |
|     |              |       |         |                   |               | MF0068143 | 1        | 814 |            |     |
|     |              |       |         |                   |               | MF0068126 | 1        | 819 |            |     |
|     |              |       |         |                   |               | MF0068154 | 1        | 824 |            |     |
| (B) | KLAFF        | VOLET | KLAPPEN | FLAP              | COMPLETE SET  | MF0068127 | 1        | 810 | -KU        |     |
|     |              |       |         |                   |               | MF0068133 | 1        | 814 |            |     |
|     |              |       |         |                   |               | MF0068144 | 1        | 819 |            |     |
|     |              |       |         |                   |               | MF0068155 | 1        | 824 |            |     |
| (C) | KLAFF        | VOLET | KLAPPEN | FLAP VLOUME       | COMPLETE SET  | *         | 1        | 810 | -KU VOLUME |     |
|     |              |       |         |                   |               | *         | 1        | 814 |            |     |
|     |              |       |         |                   |               | MF0068192 | 1        | 819 |            |     |
|     |              |       |         |                   |               | *         | 1        | 824 |            |     |
| (D) | KLAFF        | VOLET | KLAPPEN | FLAP BACK         | COMPLETE SET  | *         | 1        | 810 | -KU BACK   |     |
|     |              |       |         |                   |               | *         | 1        | 814 |            |     |
|     |              |       |         |                   |               | *         | 1        | 819 |            |     |
| 1   | KLAFFHÅLLARE | VOLET | KLAPPEN | FLAP HOLDER (120) |               | 80068473  | 1        | XX  |            |     |
| 2   | KLAFF        | VOLET | KLAPPEN | FLAP 120X750      |               | 80068474  | 2        | 810 |            |     |
|     |              |       |         |                   |               |           | 3        | 814 |            |     |
|     |              |       |         |                   |               |           | 4        | 819 |            |     |
|     |              |       |         |                   |               |           | 5        | 824 |            |     |
|     |              |       |         |                   |               |           |          |     |            |     |
| 3   | KLAFF        | VOLET | KLAPPEN | FLAP 120X660      |               | 80068475  | 4        | 810 |            |     |
|     |              |       |         |                   |               |           | 6        | 814 |            |     |
|     |              |       |         |                   |               |           | 8        | 819 |            |     |
|     |              |       |         |                   |               |           | 10       | 824 |            |     |
| 4   | KLAFF        | VOLET | KLAPPEN | FLAP 480X279      |               | 80068373  | 1        | 810 |            |     |
|     |              |       |         |                   |               |           | 80068376 | 1   |            | 814 |
|     |              |       |         |                   |               |           | 80068428 | 1   |            | 819 |
|     |              |       |         |                   |               |           | 80068379 | 1   |            | 824 |

(XX = -810,-814,-819,-824) (\* = WHEN ORDERING THIS DETAIL SPECIFY: PAGE NUMBER + POSITION NUMBER (P) + GB-DETAIL AND SERIAL NUMBER OF YOUR GRANULATOR)

## Flap(s)

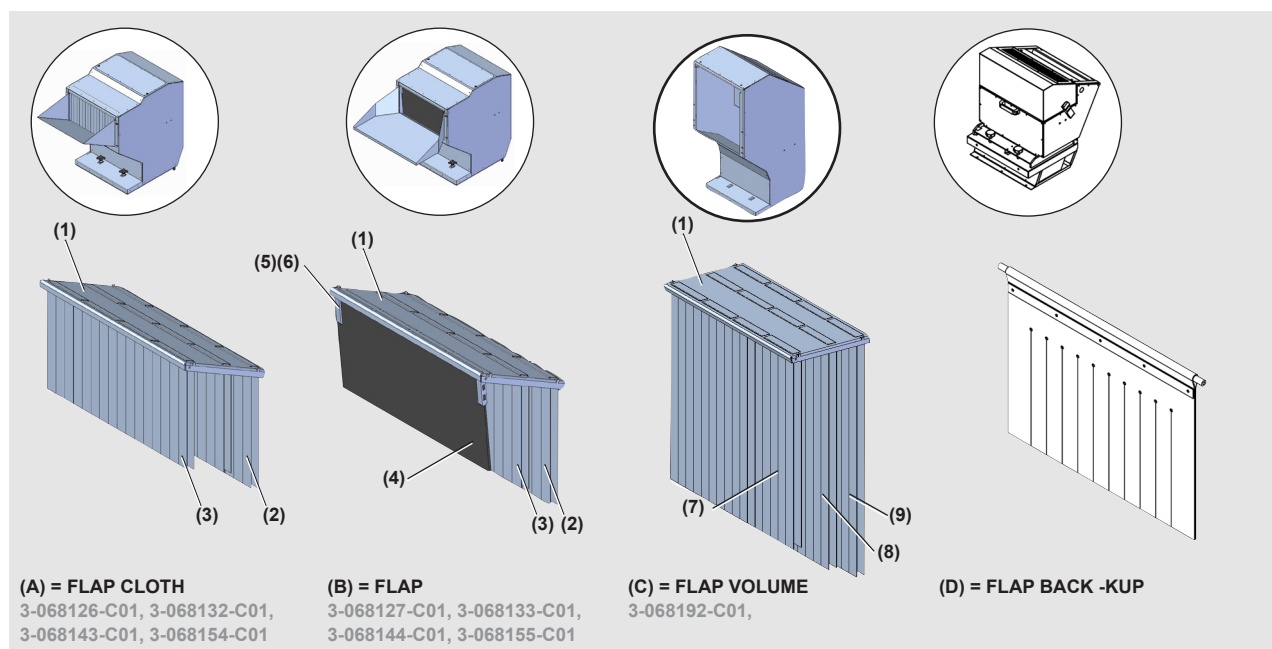

| P  | SE         | FR        | DE        | GB - DETAIL        | SPECIFICATION        | ART NO   | Q | M   | V         |
|----|------------|-----------|-----------|--------------------|----------------------|----------|---|-----|-----------|
| 5  | GÅNGJÄRN   | CHARNIÈRE | SCHARNIER | HINGE FLAP         |                      | 80068429 | 2 | XX  |           |
| 6  | AXEL KLAFF | ABRE      | ACHSE     | FLAP SHAFT D=6X502 |                      | 80068430 | 1 | XX  |           |
| 7  | KLAFF      | VOLET     | KLAPPEN   | FLAP 120X1350      |                      | 80068294 | 2 | 810 | VOLUME    |
|    |            |           |           |                    |                      |          | 3 | 814 |           |
|    |            |           |           |                    |                      |          | 4 | 819 |           |
|    |            |           |           |                    |                      |          | 5 | 824 |           |
| 8  | KLAFF      | VOLET     | KLAPPEN   | FLAP 120X1550      |                      | 80068296 | 2 | 810 |           |
|    |            |           |           |                    |                      |          | 3 | 814 |           |
|    |            |           |           |                    |                      |          | 4 | 819 |           |
|    |            |           |           |                    |                      |          | 5 | 824 |           |
| 9  | KLAFF      | VOLET     | KLAPPEN   | FLAP 120X1650      |                      | 80068295 | 2 | 810 |           |
|    |            |           |           |                    |                      |          | 3 | 814 |           |
|    |            |           |           |                    |                      |          | 4 | 819 |           |
|    |            |           |           |                    |                      |          | 5 | 824 |           |
| 10 | KLAFF      | VOLET     | KLAPPEN   | FLAP               | 240X360 PURE STRIPED | *        | 1 | 810 | -KUP BACK |
|    |            |           |           |                    | 360X360 PURE STRIPED | *        | 1 | 814 |           |
|    |            |           |           |                    | 480X360 PURE STRIPED | *        | 1 | 819 |           |
| 11 | AXEL       | ARBRE     | ACHSE     | SHAFT              | D=12X284 2XM6        | *        | 1 | XX  |           |
| 12 | SKRUV      | VIS       | SCHRAUBE  | SCREW              | SHS MC6S 6X16        | *        | 2 | XX  |           |
| 13 | BRICKA     | RONDELLE  | SCHEIBE   | WASHER             | HARDNED M6 TYPE TBRS | *        | 2 | XX  |           |
| 14 | PLUGG      | BOUCHON   | STECKER   | PLUG               | IKP 38-31/33 S       | *        | 2 | XX  |           |

(XX = -810,-814,-819,-824) (\* = WHEN ORDERING THIS DETAIL SPECIFY: PAGE NUMBER + POSITION NUMBER (P) + GB-DETAIL AND SERIAL NUMBER OF YOUR GRANULATOR)

## Funnel, Feed tray, Inlet

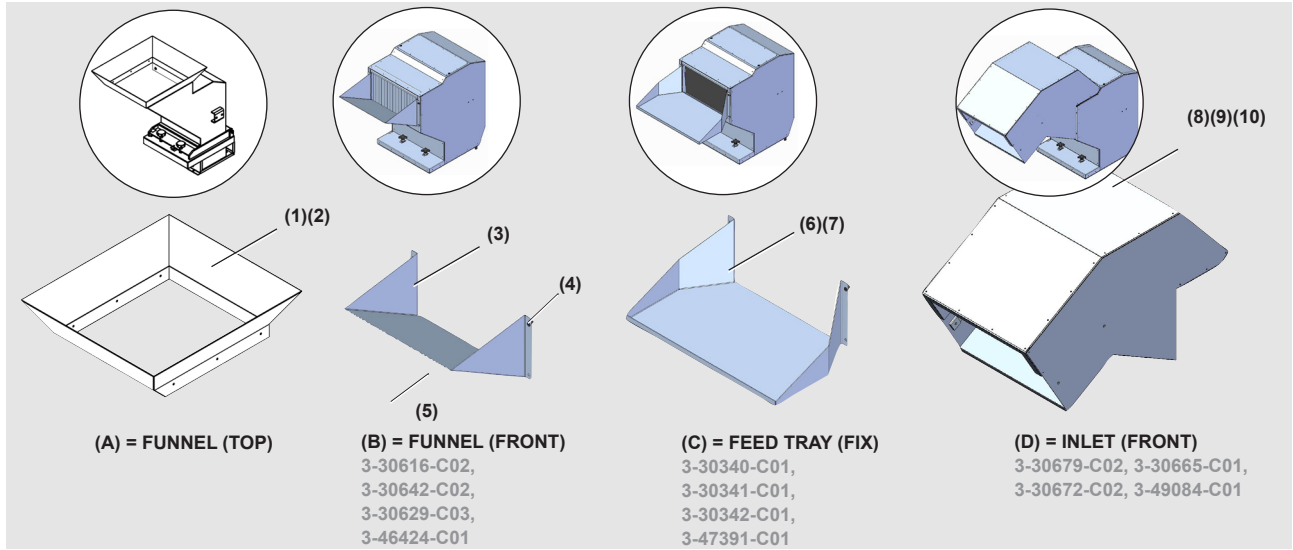

| P  | SE        | FR            | DE           | GB - DETAIL | SPECIFICATION          | ART NO     | Q  | M   | V     |
|--|-----------|---------------|--------------|-------------|------------------------|------------|----|-----|-------|
| (A)  | TRATT     | ENTONNOIR     | TRICHTERAUFS | FUNNEL      | COMPLETE SET           | *          | 1  | 810 | TOP   |
|  |           |               |              |             |                        | *          | 1  | 814 |       |
|  |           |               |              |             |                        | *          | 1  | 819 |       |
|  |           |               |              |             |                        | *          | 1  | 824 |       |
| (B)  | TRATT     | ENTONNOIR     | TRICHTERAUFS | FUNNEL      | COMPLETE SET           | MF330616   | 1  | 810 | FRONT |
|  |           |               |              |             |                        | MF330642   | 1  | 814 |       |
|  |           |               |              |             |                        | MF330629   | 1  | 819 |       |
|  |           |               |              |             |                        | MF346424   | 1  | 824 |       |
| (C)  | MATARBORD | PLATEAU D'ALI | AUFGABETISC  | FEED TRAY   | COMPLETE SET           | MF330340   | 1  | 810 | FIX   |
|  |           |               |              |             |                        | MF330341   | 1  | 814 |       |
|  |           |               |              |             |                        | MF330342   | 1  | 819 |       |
|  |           |               |              |             |                        | MF347391   | 1  | 824 |       |
| (D)  | INLOPP    | ENTRÉE        | EINLASS      | INLET       | COMPLETE SET           | MF330679   | 1  | 810 | INLET |
|  |           |               |              |             |                        | MF330665   | 1  | 814 |       |
|  |           |               |              |             |                        | MF330672   | 1  | 819 |       |
|  |           |               |              |             |                        | MF349084   | 1  | 824 |       |
| 1  | TRATT     | ENTONNOIR     | TRICHTERAUFS | FUNNEL      | 350X520 BLACK          | *          | 1  | 810 | TOP   |
|  |           |               |              |             | 470X520 BLACK          | *          | 1  | 814 |       |
|  |           |               |              |             | 590X520 BLACK          | *          | 1  | 819 |       |
|  |           |               |              |             | 710X520 BLACK          | *          | 1  | 824 |       |
| 2  | NIT       | RIVET         | NIET         | RIVET       | KN 5X16MM FZB          | *          | XX | 6   |       |
| 3  | TRATT     | ENTONNOIR     | TRICHTERAUFS | FUNNEL      | BLACK                  | 8229789    | 1  | 810 | FRONT |
|  |           |               |              |             |                        | 8229788    | 1  | 814 |       |
|  |           |               |              |             |                        | 8229790    | 1  | 819 |       |
|  |           |               |              |             |                        | 8246423-01 | 1  | 824 |       |
| 4  | SKRUV     | VIS           | SCHRAUBE     | SCREW       | SHS MC6LS 8X20         | 9-40587    | 4  | XX  |       |
| 5  | LIST      | BAGUETTE      | LEISTE       | SEALING     | KRONLIST 9 X 3 MM, BLA | 9-92455    | 1  | XX  |       |
| (FRONT = FUNNEL FOR HOPPER FRONT) (TOP= FUNNEL FOR HOPPER TOP) (INLET = INLET FOR HOPPER FRONT)<br>(FIX= FIXED FEED TRAY) (FA= FOLDABLE FEED TRAY) (XX = -810,-814,-819,-824)<br>(* = WHEN ORDERING THIS DETAIL SPECIFY: PAGE NUMBER + POSITION NUMBER (P) + GB-DETAIL AND SERIAL NUMBER OF YOUR GRANULATOR) |           |               |              |             |                        |            |    |     |       |

### Funnel, Feed tray, Inlet

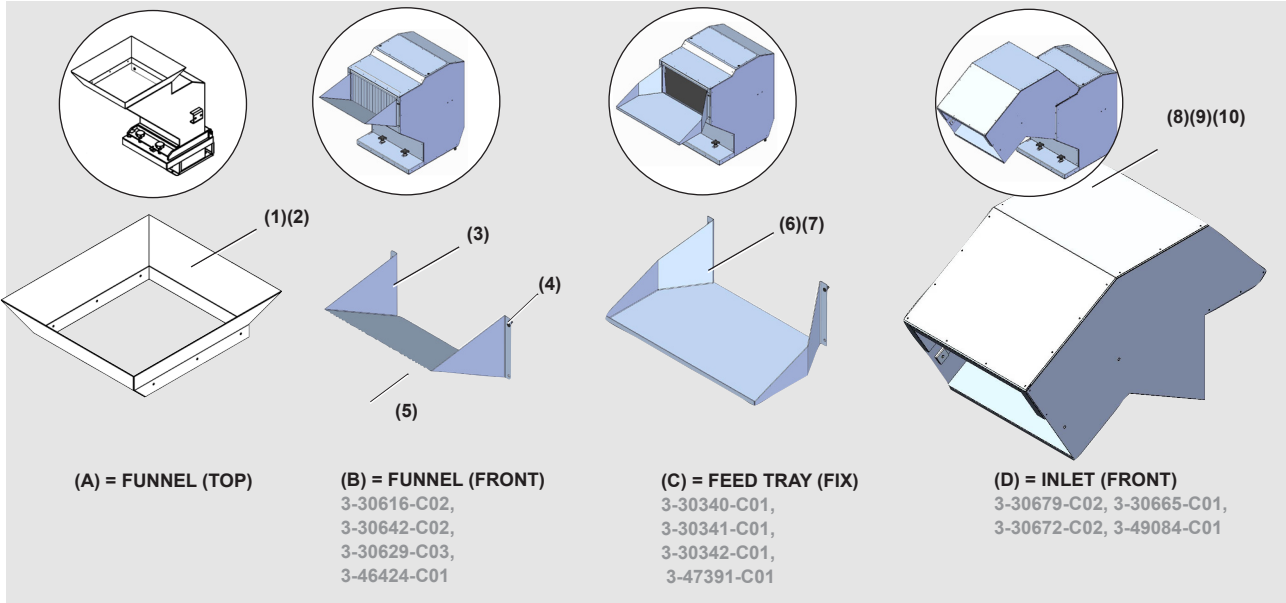

| P  | SE        | FR  | DE          | GB - DETAIL  | SPECIFICATION         | ART NO   | Q | M   | V     |
|----|-----------|---|-------------|--|-----------------------|--|---|-----|-------|
| 6  | MATARBORD | PLATEAU D'ALI   | AUFGABETISC | FEED TRAY  | BLACK                 | 8230494  | 1 | 810 | FIX   |
|    |           |   |             |  |                       | 8229787  | 1 | 814 |       |
|    |           |   |             |  |                       | 8230641  | 1 | 819 |       |
|    |           |   |             |  |                       | 8247384-01   | 1 | 824 |       |
| 7  | SKRUV     | VIS   | SCHRAUBE    | SCREW  | SHS MC6LS 8X20        | 9-40587  | 4 | XX  |       |
| 8  | INLET     | ENTRÉE  | EINLASS     | INLET  | SOUND TRAP            | 8230673  | 1 | 810 | INLET |
|    |           |   |             |  |                       | 8230654  | 1 | 814 |       |
|    |           |   |             |  |                       | 8230666  | 1 | 819 |       |
|    |           |   |             |  |                       | 8249083  | 1 | 824 |       |
| 9  | SKRUV     | VIS   | SCHRAUBE    | SCREW  | SHS MC6S 8X16-12      | 9-40032  | 4 | 810 | INLET |
|    |           |   |             |  | SHS MC6S8X20-12       | 9-40070  | 4 | 814 |       |
|    |           |   |             |  | SHS MC6S 8X16-12      | 9-40032  | 4 | 819 |       |
|    |           |   |             |  | SHS MC6S 8X25-12      | 9-40097  | 4 | 824 |       |
| 10 | LIST      | BAGUETTE  | LEISTE      | SEALING  | SELF-ADHESIVE 15X8 EP | 9-70218  | 1 | XX  |       |
|    |           | (FRONT = FUNNEL FOR HOPPER FRONT)<br>(FIX= FIXED FEED TRAY) |             | (TOP= FUNNEL FOR HOPPER TOP)<br>(FA= FOLDABLE FEED TRAY) |                       | (INLET = INLET FOR HOPPER FRONT)<br>(XX = -810,-814,-819,-824) |   |     |       |

# Hopper

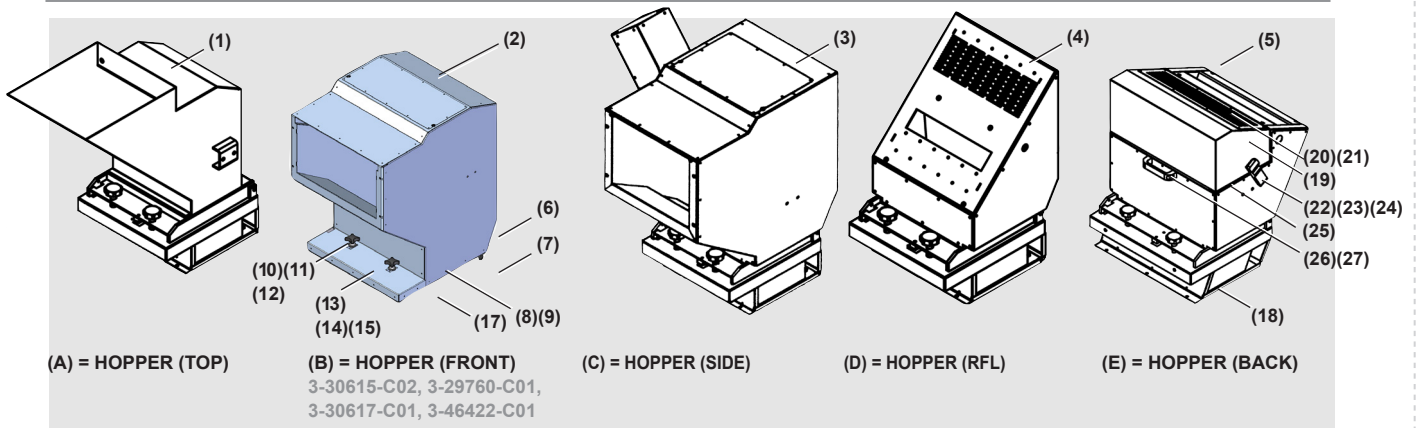

| P   | SE        | FR          | DE       | GB - DETAIL | SPECIFICATION           | ART NO   | Q | M   | V      |
|-----|-----------|-------------|----------|-------------|-------------------------|----------|---|-----|--------|
| (A) | INMATNING | ALIMENTATIO | TRICHTER | HOPPER      | COMPLETE SET            | *        | 1 | 810 | TOP    |
|     |           |             |          |             |                         | *        | 1 | 814 |        |
|     |           |             |          |             |                         | *        | 1 | 819 |        |
|     |           |             |          |             |                         | *        | 1 | 824 |        |
| (B) | INMATNING | ALIMENTATIO | TRICHTER | HOPPER      | COMPLETE SET            | MF330615 | 1 | 810 | FRONT  |
|     |           |             |          |             |                         | MF329760 | 1 | 814 |        |
|     |           |             |          |             |                         | MF330617 | 1 | 819 |        |
|     |           |             |          |             |                         | MF346422 | 1 | 824 |        |
| (C) | INMATNING | ALIMENTATIO | TRICHTER | HOPPER      | COMPLETE SET            | *        | 1 | 810 | SIDE L |
|     |           |             |          |             |                         | *        |   | 814 |        |
|     |           |             |          |             |                         | *        | 1 | 819 |        |
| (D) | INMATNING | ALIMENTATIO | TRICHTER | HOPPER      | COMPLETE SET            | *        | 1 | 814 | RFL    |
|     |           |             |          |             |                         | *        | 1 | 819 |        |
|     |           |             |          |             |                         | *        | 1 | 824 |        |
| (E) | INMATNING | ALIMENTATIO | TRICHTER | HOPPER      | COMPLETE SET            | *        | 1 | 810 | BACK   |
|     |           |             |          |             |                         | *        | 1 | 814 |        |
|     |           |             |          |             |                         | *        | 1 | 819 |        |
| 1   | INMATNING | ALIMENTATIO | TRICHTER | HOPPER      | TOP 240X410             | 8244873  | 1 | 810 | TOP    |
|     |           |             |          |             | TOP 360X410             | 8244695  | 1 | 814 |        |
|     |           |             |          |             | TOP 480X410             | 8244881  | 1 | 819 |        |
|     |           |             |          |             | TOP 600X410             | 8246067  | 1 | 824 |        |
| 2   | INMATNING | ALIMENTATIO | TRICHTER | HOPPER      | FRONT 240X220           | 8130614  | 1 | 810 | FRONT  |
|     |           |             |          |             | FRONT 360X220           | 8129761  | 1 | 814 |        |
|     |           |             |          |             | FRONT 480X220           | 8130618  | 1 | 819 |        |
|     |           |             |          |             | FRONT 600X220           | 8146421  | 1 | 824 |        |
| 3   | INMATNING | ALIMENTATIO | TRICHTER | HOPPER      | FRONT 240X220 SIDE L 10 | 8137332  | 1 | 810 | SIDE L |
|     |           |             |          |             | FRONT 360X220 SIDE L 10 | 8141731  | 1 | 814 |        |
|     |           |             |          |             | FRONT 480X220 SIDE L 10 | 8135459  | 1 | 819 |        |
| 4   | INMATNING | ALIMENTATIO | TRICHTER | HOPPER      | FRONT 300X64 45 DEG     | 8235456  | 1 | 814 | RFL    |
|     |           |             |          |             | FRONT 450X64 45 DEG     | 8238557  | 1 | 819 |        |
|     |           |             |          |             | FRONT 600X64 45 DEG     | 8146471  | 1 | 824 |        |
| 5   | INMATNING | ALIMENTATIO | TRICHTER | HOPPER      | BACK 240X80             | 8234045  | 1 | 810 | BACK   |
|     |           |             |          |             | BACK 360X80             | 8234222  | 1 | 814 |        |
|     |           |             |          |             | BACK 480X80             | 8234039  | 1 | 819 |        |

(TOP = HOPPER TOP) (FRONT = HOPPER FRONTAL BASIC) (SIDE L = HOPPER FRONT AND INLET LEFT) (RFL = HOPPER 45 DEG FOR ROLLER FEEDER) (BACK = HOPPER BACK -KUP) (XX = -810,-814,-819,-824) (ALL = ALL VARIANTS) (\* = WHEN ORDERING THIS DETAIL SPECIFY: PAGE NUMBER + POSITION NUMBER (P) + GB-DETAIL AND SERIAL NUMBER OF YOUR GRANULATOR)

# Hopper

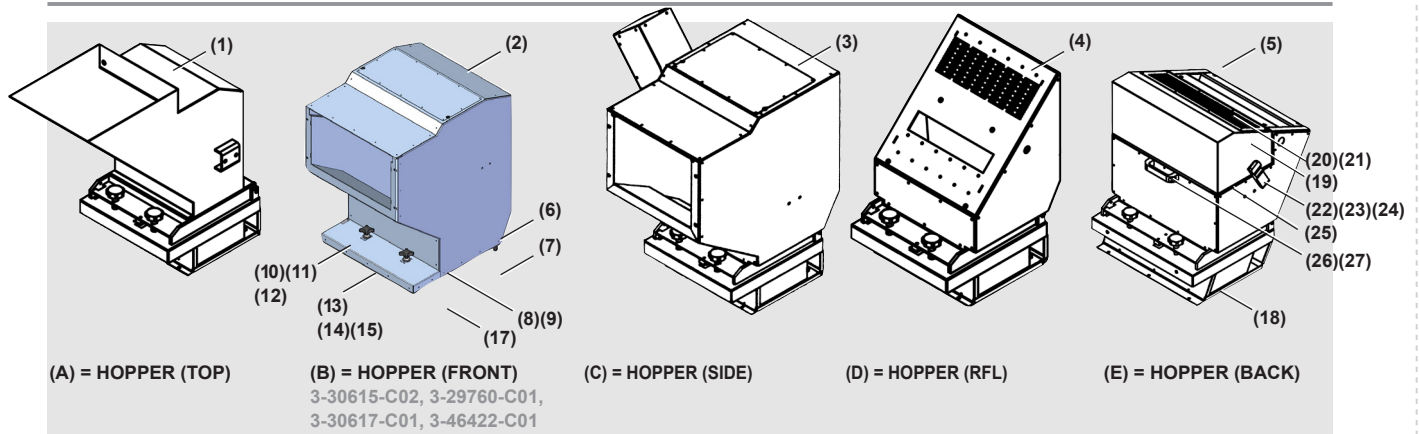

| P  | SE         | FR            | DE          | GB - DETAIL  | SPECIFICATION          | ART NO  | Q    | M   | V    |                 |
|----|------------|---------------|-------------|--------------|------------------------|---------|------|-----|------|-----------------|
| 6  | AXEL       | ARBRE         | ACHSE       | SHAFT        | D=12X284               | 8430495 | 1    | 810 | ALL  |                 |
|    |            |               |             |              | D=12X404               | 8429734 | 1    | 814 |      |                 |
|    |            |               |             |              | D=10X524               | 8430628 | 1    | 819 |      |                 |
|    |            |               |             |              | D=12X644               | 8446076 | 1    | 824 |      |                 |
| 7  | SKRUV      | VIS           | SCHRAUBE    | SCREW        | SHS MC6S 8X25          | 9-40097 | 6    | XX  |      |                 |
| 8  | TÄTNING    | ÉTANCHÉITÉ    | DICHTUNG    | SEALING      | LIST KRONLIST 9 X 3 MM | 9-92455 | 3.5M | XX  |      |                 |
| 9  | TÄTNING    | ÉTANCHÉITÉ    | DICHTUNG    | SEALING      | LIST SELF-ADHESIVE 15X | 9-70218 | 0.5M | XX  |      |                 |
| 10 | LÄSBULT    | BOULON VERR   | SPERRBOLZEN | LOCKING BOLT | M12X85 31/44           | 8430328 | 1    | XX  |      |                 |
| 11 | LÄSBULT    | BOULON VERR   | SPERRBOLZEN | LOCKING BOLT | M12X85 36/39           | 8430327 | 1    | XX  |      |                 |
| 12 | STJÄRNVRED | POIGNÉE ÉTOIL | STERNGRIF   | STAR KNOB    | GN 6335.1 E63-M12      | 9-50532 | 2    | XX  |      |                 |
| 13 | FÄSTE      | FIXATION      | BEFESTIGUN  | BRACKET      | SWITCH BLACK           | 8429646 | 1    | XX  |      |                 |
| 14 | SKRUV      | VIS           | SCHRAUBE    | SCREW        | SHS MC6S 5X10          | 9-40071 | 2    | XX  |      |                 |
| 15 | BRICKA     | RONDELLE      | SCHEIBE     | WASHER       | BRB 13,0               | 9-40155 | 4    | XX  |      |                 |
| 16 | SKRUV      | VIS           | SCHRAUBE    | GRUB SCREW   | S6SS 6X6               | 9-40696 | 1    | XX  |      |                 |
| 17 | INMATN RAM | CADRE         | RAHMEN      | HOPPER FRAME | ---                    | 8129595 | 1    | 810 |      | ALL EXCEPT BACK |
|    |            |               |             |              |                        | 8129596 | 1    | 814 |      |                 |
|    |            |               |             |              |                        | 8129597 | 1    | 819 |      |                 |
|    |            |               |             |              |                        | 8146075 | 1    | 824 |      |                 |
| 18 | INMATN RAM | CADRE         | RAHMEN      | HOPPER FRAME | KNIFE FIXED 3:RD       | *       |      |     | BACK |                 |
|    |            |               |             |              |                        | *       |      |     |      |                 |
|    |            |               |             |              |                        | *       |      |     |      |                 |
| 19 | LJUDFÄLLA  | SILENCIEUX    | SCHALLHAUB  | SOUND TRAP   | AIR INLET              | *       |      |     | BACK |                 |
|    |            |               |             |              |                        | *       |      |     |      |                 |
|    |            |               |             |              |                        | *       |      |     |      |                 |
| 20 | PLÅT       | PLAQUE        | BLECH       | COVER PLATE  | SOUND TRAP             | *       |      |     |      |                 |
|    |            |               |             |              |                        | *       |      |     |      |                 |
|    |            |               |             |              |                        | *       |      |     |      |                 |
| 21 | SKRUV      | VIS           | SCHRAUBE    | SCREW        | MONTAGE DRILWI 4,8X16  | *       |      |     |      |                 |
|    |            |               |             |              |                        |         |      |     |      |                 |
|    |            |               |             |              |                        |         |      |     |      |                 |
| 22 | LÄS        | VERROU        | ARRETIERUN  | TOGGLE       | C7-20                  | *       |      |     |      |                 |
| 23 | SKRUV      | VIS           | SCHRAUBE    | SCREW        | SHS MC6S 12X25         | *       |      |     |      |                 |
| 24 | POPINIT    | RIVET         | NIET        | POP RIVET    | STEEL D 4,8X10,5       | *       |      |     |      |                 |
| 25 | TÄTNING    | ÉTANCHÉITÉ    | DICHTUNG    | SEALING      | LIST SELF-AD FOAM RU   | *       |      |     |      |                 |
| 26 | HANDTAG    | POIGNÉE       | GRIF        | HANDLE       | CLAMP VN 130132-M8     | *       |      |     |      |                 |
| 27 | SKRUV      | VIS           | SCHRAUBE    | SCREW        | SHS MC6S 8X20          | *       |      |     |      |                 |

(TOP = HOPPER TOP) (FRONT = HOPPER FRONTAL BASIC) (SIDE L = HOPPER FRONT AND INLET LEFT)  
 (RFL = HOPPER 45 DEG FOR ROLLER FEEDER) (BACK = HOPPER BACK -KUP) (XX = -810,-814,-819,-824) (ALL = ALL VARIANTS)

## Hopper device

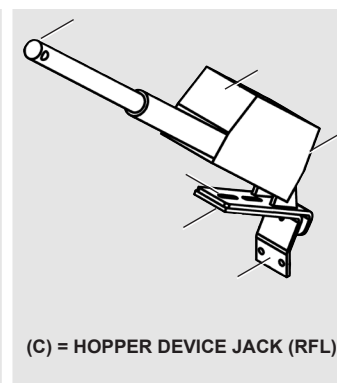
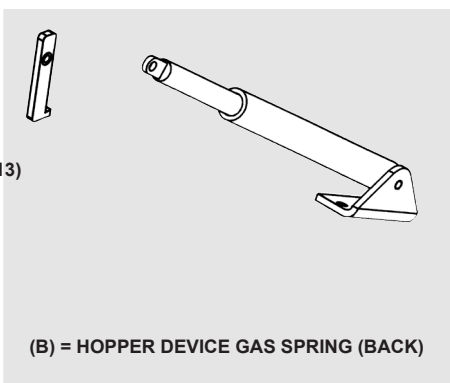
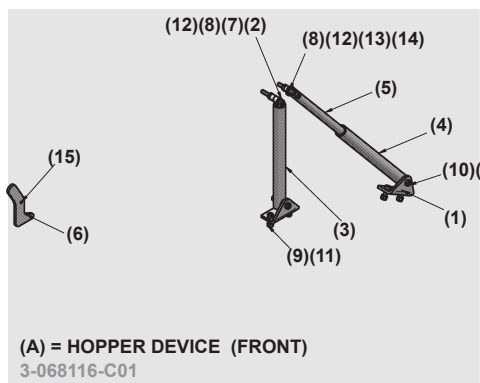

| P  | SE         | FR          | DE         | GB - DETAIL     | SPECIFICATION                 | ART NO   | Q | M  | V     |
|----|------------|-------------|------------|-----------------|-------------------------------|----------|---|----|-------|
| 1  | FÄSTE      | FIXATION    | BEFESTIGUN | BRACKET         | M8 GAS SPRING BLACK           | 8329777  | 2 | XX | FRONT |
| 2  | HYLSA      | DOUILLE     | BUCHSE     | SLEEVE          | D=14/9X11,5                   | 8440637  | 1 | XX |       |
| 3  | HYLSA      | DOUILLE     | BUCHSE     | SLEEVE          | D=28/20X282 GAS SPRING        | 80068432 | 1 | XX |       |
| 4  | HYLSA      | DOUILLE     | BUCHSE     | SLEEVE          | D=28/20X316 GAS SPRING        | 80068433 | 1 | XX |       |
| 5  | HYLSA      | DOUILLE     | BUCHSE     | SLEEVE          | D=19/16X296 GAS SPRING        | 80068434 | 1 | XX |       |
| 6  | STOPP      | STOP        | STOP       | STOP            |                               | 80068435 | 1 | XX |       |
| 7  | GASFJÄDER  | RESS AU GAS | GASFEDER   | GAS SPRING      | 0308-120-084263/700<br>D=19/8 | 9-20832  | 1 | XX |       |
| 8  | SKRUV      | VIS         | SCHRAUBE   | SCREW           | SHS MC6S M8X60-12.9           | 9-40029  | 2 | XX |       |
| 9  | SKRUV      | VIS         | SCHRAUBE   | SCREW           | SHS MC6S M8X20-12.9           | 9-40070  | 4 | XX |       |
| 10 | SKRUV      | VIS         | SCHRAUBE   | SCREW           | SHS MC6S M8X45-12.9           | 9-40140  | 2 | XX |       |
| 11 | MUTTER     | ÉCROU       | MUTTER     | NUT LOC-KING    | M8-8.8                        | 9-40317  | 4 | XX |       |
| 12 | MUTTER     | ÉCROU       | MUTTER     | NUT             | M6M M8 FZB                    | 9-40045  | 2 | XX |       |
| 13 | BRICKA     | RONDELLE    | SCHEIBE    | WASHER HARDENED | M8 AMF DIN 8,4/23-4           | 9-40585  | 3 | XX |       |
| 14 | PLUGG      | BOUCHON     | STECKER    | PLUG            | IKP D=19/15-17X19 S           | 9-50430  | 1 | XX |       |
| 15 | SPÄNNSTIFT | GOUPILLE    | SPANNSTIFT | SPRING PIN      | FRP D=6X28                    | 9-50077  | 1 | XX |       |

(XX = -810,-814,-819,-824) (FRONT = HOPPER DEVICE FOR HOPPER FRONT) (BACK = HOPPER DEVICE FOR HOPPER BACK)  
(RFL = HOPPER DEVICE FOR HOPPER MIT ROLLER FEEDER)

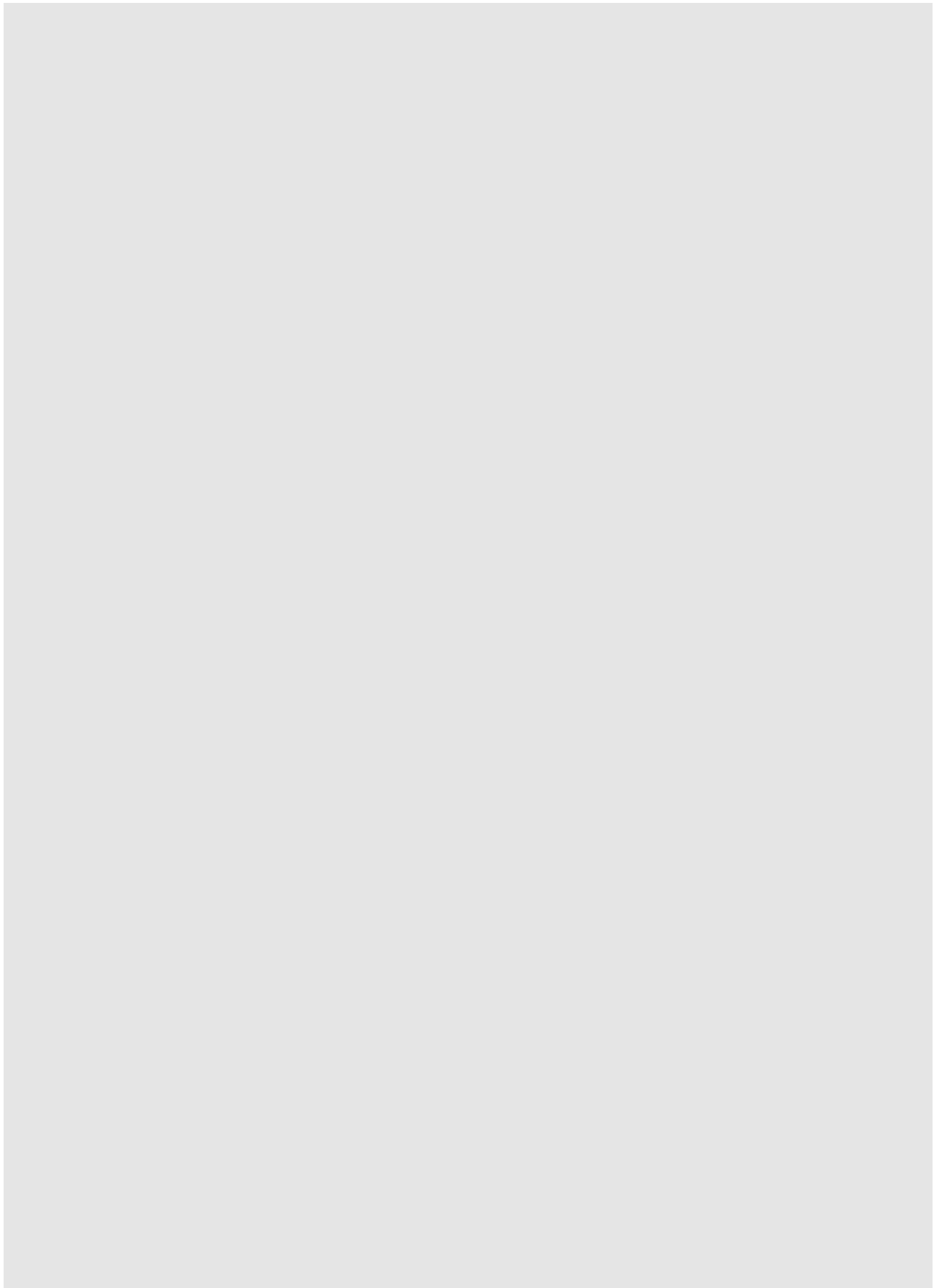

### Safety

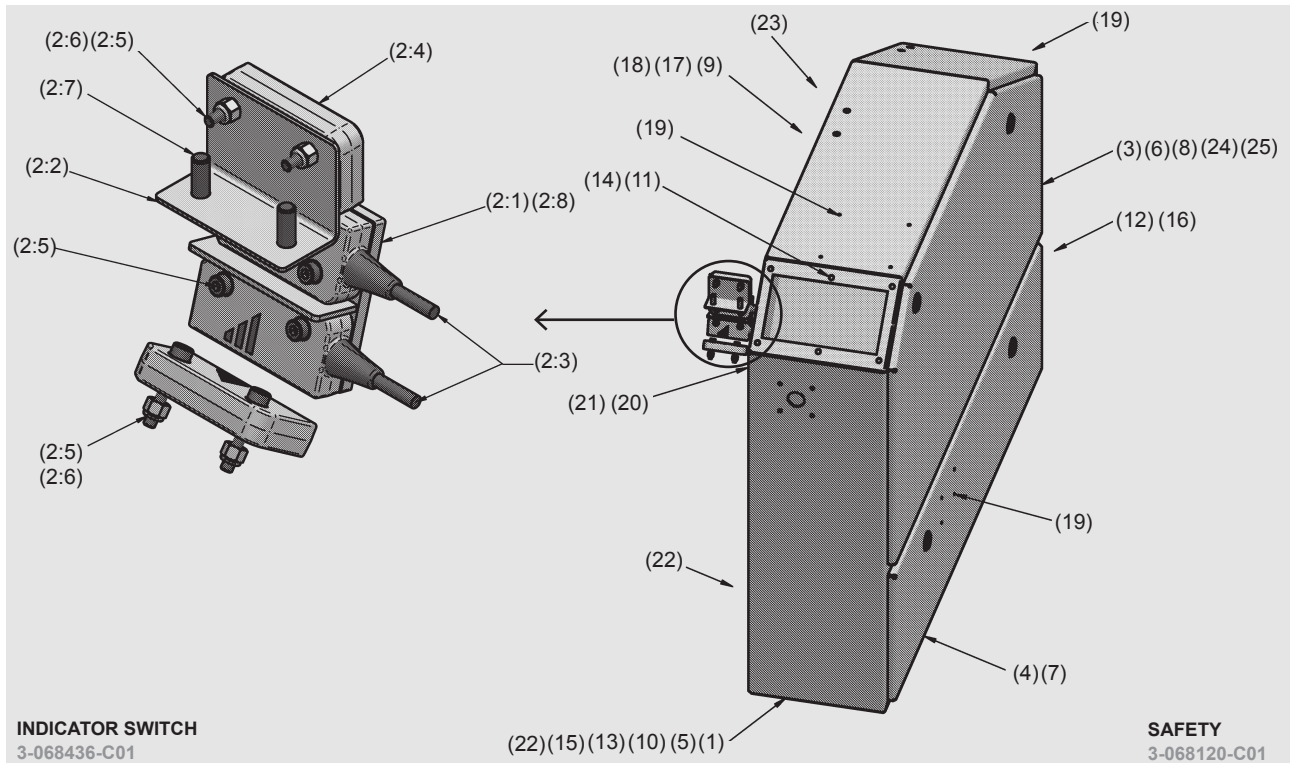

**INDICATOR SWITCH**  
3-068436-C01

**SAFETY**  
3-068120-C01

| P   | SE                   | FR                      | DE                   | GB - DETAIL                | SPECIFICATION         | ART NO   | Q | M  | V   |
|-----|----------------------|-------------------------|----------------------|----------------------------|-----------------------|----------|---|----|-----|
| 1   | KÄPA H<br>GETRIEBE   | CAPOT                   | HAUBE                | COVER R TRANSMIS-<br>SION  |                       | 80068300 | 1 | XX |     |
| 2:1 | FÄSTE                | FIXATION                | BEFESTIGUN           | BRACKET                    |                       | 80068440 | 1 | XX |     |
| 2:2 | FÄSTE INMAT-<br>NING | FIXATION<br>ALIMENTATIO | BEFESTIGUN<br>HOPPER | BRACKET HOPPER<br>(BLACK)  |                       | 80068438 | 1 | XX |     |
| 2:3 | BRYTARE              | DISJONCT                | SCHALTER             | SAFETY SENSOR<br>EDEN ADAM |                       | 9-94839  | 2 | XX |     |
| 2:4 | BRYTARE              | DISJONCT                | SCHALTER             | SAFETY SENSOR<br>EDEN EVA  |                       | 9-94841  | 2 | XX |     |
| 2:5 | SKRUV                | VIS                     | SCHRAUBE             | SCREW                      | SHS MC6S 4X25-12.9    | 9-40638  | 8 | XX |     |
| 2:6 | MUTTER               | ÉCROU                   | MUTTER               | NUT LOC-KING               | M4-8.8                | 9-40315  | 4 | XX |     |
| 2:7 | SKRUV                | VIS                     | SCHRAUBE             | SCREW                      | SHS K6S 6X16-10.9     | 9-40801  | 2 | XX |     |
| 2:8 | SKRUV                | VIS                     | SCHRAUBE             | SCREW                      | SHS MF6S 8X12-10.9    | 9-41053  | 2 | XX |     |
| 3   | LOCK                 | COUVERCLE               | DECKEL               | COVER                      |                       | 8240844  | 1 | XX |     |
| 4   | LUCKA EL             | PORTE<br>ÉLECTRIQUE     | TÜR ELEKTRIK         | DOOR ELECTRICS             |                       | 80068466 | 1 | XX | ALL |
| 5   | ABSORBENT            | AMORTISSEU              | DÄMPFER              | ABSORBER                   | 4X765X464             | 80068468 | 1 | XX |     |
| 6   | BULLER<br>ABSORBENT  | AMORTISSEU              | SCHALL<br>DÄMPFER    | NOISE ABSORBER             | 10X847X422            | 8441102  | 1 | XX |     |
| 7   | DÖRRLÅS              | VERROU                  | SCHLOSS              | LOCK DOOR BLACK            | A=20 L=45 D=22,5      | 9-94863  | 2 | XX |     |
| 8   | DÖRRLÅS              | VERROU                  | SCHLOSS              | LOCK DOOR BLACK            | A16 L=45 D=22,5       | 9-94864  | 2 | XX |     |
| 9   | DÄMPARE              | AMORTISSEU              | DÄMPFER              | DAMPER                     | D=30X15 2X M8X15 HR40 | 9-50784  | 1 | XX |     |
| 10  | SKRUV                | VIS                     | SCHRAUBE             | SCREW TAPPING<br>TAPTITE   | 8X16-8.8              | 9-40444  | 4 | XX |     |
| 11  | SKRUV                | VIS                     | SCHRAUBE             | SCREW TORX KTS             | 5 X 16-8.8 KVAL       | 9-40777  | 6 | XX |     |
| 12  | SKRUV                | VIS                     | SCHRAUBE             | SCREW                      | SHS MC6S 5X14-12.9    | 9-40076  | 4 | XX |     |
| 13  | SKRUV                | VIS                     | SCHRAUBE             | SCREW TAPPING<br>TAPTITE   | M5X12                 | 9-41047  | 2 | XX |     |

(XX = -810,-814,-819,-824) (FRONT = HOPPER DEVICE FOR HOPPER FRONT) (BACK = HOPPER DEVICE FOR HOPPER BACK)  
(RFL = HOPPER DEVICE FOR HOPPER WITH ROLLER FEEDER)

Safety

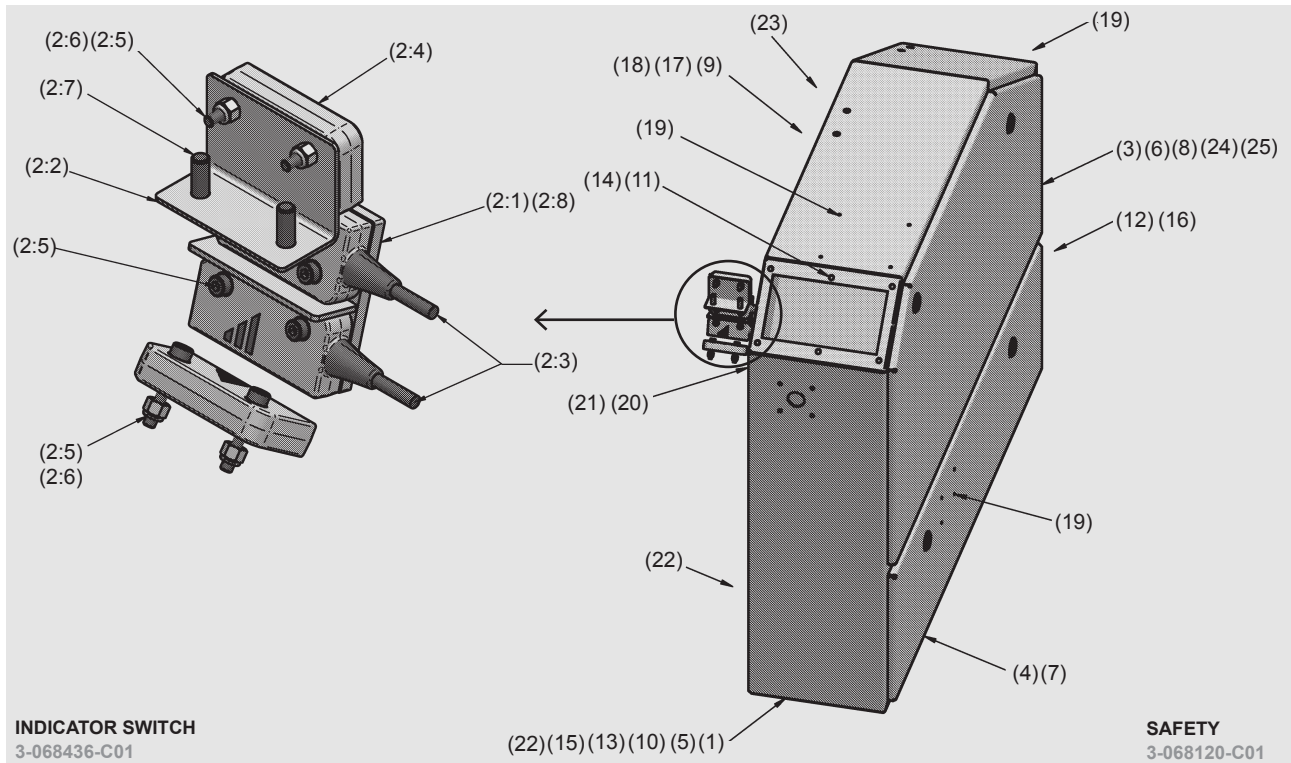

| P  | SE                 | FR                     | DE                     | GB - DETAIL               | SPECIFICATION    | ART NO  | Q  | M  | V   |
|----|--------------------|------------------------|------------------------|---------------------------|------------------|---------|----|----|-----|
| 14 | MUTTER<br>BLINDNIT | ÉCROU                  | MUTTER                 | NUT BLIND RIVET           | M5 0.5-2.0 STEEL | 9-50247 | 6  | XX | ALL |
| 15 | MUTTER<br>BLINDNIT | ÉCROU                  | MUTTER                 | NUT BLIND RIVET           | M6 0.5-3.0 STEEL | 9-50321 | 6  | XX |     |
| 16 | MUTTER             | ÉCROU                  | MUTTER                 | NUT LOC-KING              | M5 A4-80 DIN985  | 9-40912 | 4  | XX |     |
| 17 | MUTTER             | ÉCROU                  | MUTTER                 | NUT LOC-KING              | M8-8.8           | 9-40317 | 1  | XX |     |
| 18 | BRICKA             | RONDELLE               | SCHEIBE                | WASHER BODY               | 8,4 X 24 X 2 FZB | 9-40592 | 1  | XX |     |
| 19 | POP-NIT            | RIVET                  | NIET                   | POP-RIVET                 | ALUMINIUM D 3,2  | 9-40256 | 12 | XX |     |
| 20 | SLANG SKYDD        | PROTECTION<br>DE TUYAU | SCHLAUCHAB-<br>DECKUNG | HOSE PROTECTION           | PAFL 13MM        | 9-10862 | 2  | XX |     |
| 21 | FÖRSKRUV-<br>NING  | GLANDE                 | VER-<br>SCHRAUBUNG     | FITTING, HOSE             | BVWD-M160GT      | 9-11944 | 2  | XX |     |
| 22 | LIST CELLO         | BAGUETTE               | LEISTE                 | LIST CELLO 10X6           | 10X6             | 9-70345 | 1  | XX |     |
| 23 | LIST               | BAGUETTE               | LEISTE                 | LIST SELF-ADHESIVE        | 15X8 EPDM        | 9-70218 | 1  | XX |     |
| 24 | LIST               | BAGUETTE               | LEISTE                 | LIST EDGE PROTEC-<br>TION | D=10.5X14 1-4 MM | 9-70084 | 1  | XX |     |
| 25 | LIST               | BAGUETTE               | LEISTE                 | LIST SEAL EDGE<br>EPDM    | 9,5              | 9-50613 | 1  | XX |     |

(XX = -810,-814,-819,-824)

# Cutter housing

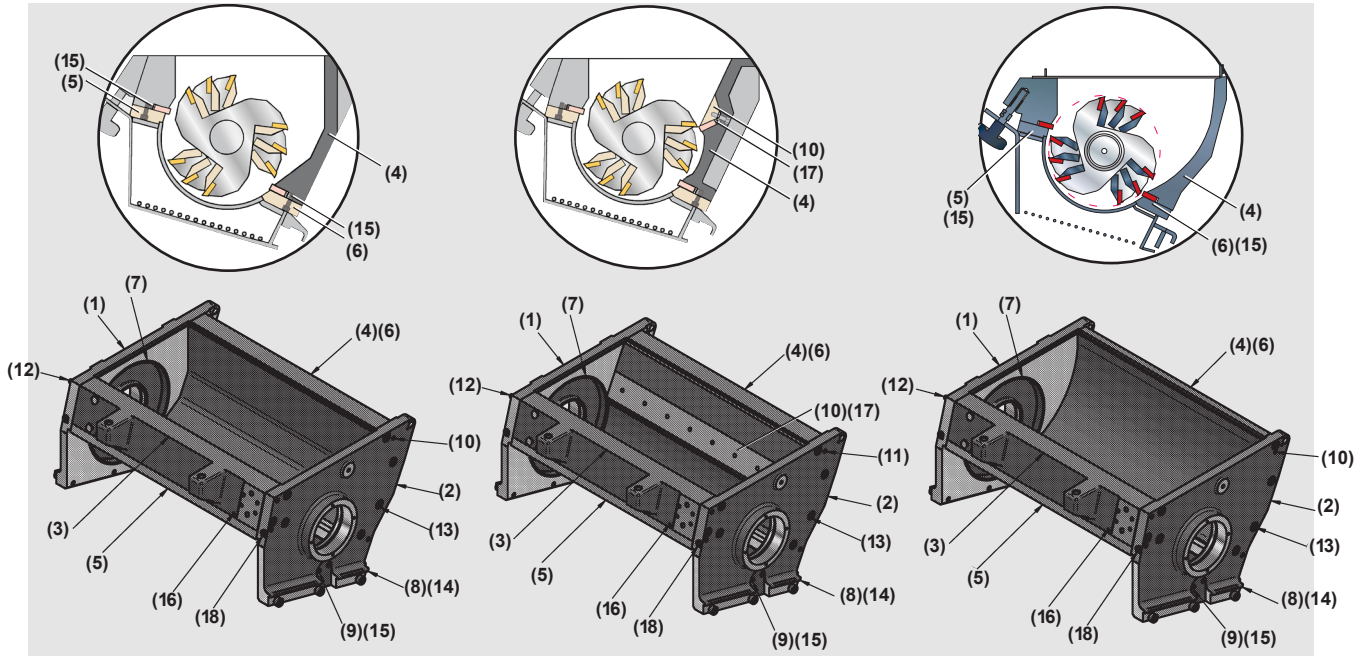

**(A) = CUTTER HOUSING 1ST "TANGENTIAL"**  
 3-68108-C01, 3-68182-C01, 3-68104-C01,  
 3-68185-C01, 3-068100-C01, 3-68179-C01,  
 3-68112-C01, 3-68188-C01

**(B) = CUTTER HOUSING 3RD "PRE-CUT"**  
 3-681209-C01, 3-68183-C01, 3-68105-C01,  
 3-68186-C01, 3-068101-C01, 3-68180-C01,  
 3-68161-C01, 3-68189-C01

**(C) = CUTTER HOUSING 5TH "SUPER-T"**  
 3-68110-C01, 3-68106-C01,  
 3-068102-C01, 3-68162-C01

| P | SE       | FR            | DE           | GB - DETAIL | SPECIFICATION | ART NO   | Q | M   | V     |
|---|----------|---------------|--------------|-------------|---------------|----------|---|-----|-------|
| 1 | SIDA V   | PARTIE GAUCHE | SEITE LINKS  | SIDE LEFT   | CU1ST, CU3RD  | 80068206 | 1 | XX  | BASIC |
|   |          |               |              |             | CU5TH         | 80068200 | 1 | XX  |       |
|   |          |               |              |             | CU1ST, CU3RD  | 80068478 | 1 | XX  | HA    |
|   |          |               |              |             | CU5TH         | 80068480 | 1 | XX  |       |
| 2 | SIDA H   | PARTIE DROIT  | SEITE RECHTS | SIDE RIGHT  | CU1ST, CU3RD  | 80068207 | 1 | XX  | BASIC |
|   |          |               |              |             | CU5TH         | 80068201 | 1 | XX  |       |
|   |          |               |              |             | CU1ST, CU3RD  | 80068479 | 1 | XX  | HA    |
|   |          |               |              |             | CU5TH         | 80068481 | 1 | XX  |       |
| 3 | FRAMSIDA | PARTIE FRON   | SEITE VORNE  | FRONT SIDE  |               | 80068212 | 1 | 810 | BASIC |
|   |          |               |              |             |               | 80068208 | 1 | 814 |       |
|   |          |               |              |             |               | 80068202 | 1 | 819 |       |
|   |          |               |              |             |               | 80068238 | 1 | 824 |       |
|   |          |               |              |             |               | 80068486 | 1 | 810 | HA    |
|   |          |               |              |             |               | 80068490 | 1 | 814 |       |
|   |          |               |              |             |               | 80068482 | 1 | 819 |       |
|   |          |               |              |             |               | 80068494 | 1 | 824 |       |

(CU1ST = CUTTER HOUSING 1ST) (CU1STH = CUTTER HOUSING 1ST HARDENED) (1ST = KNIFE SEAT FIRST) (2ND = KNIFE SEAT 2ND)  
 (CU3RD = CUTTER HOUSING 3RD) (CU3RDH = CUTTER HOUSING 3RD HARDENED) (3RD = KNIFE SEAT 3RD) (XX = -810,-814,-819,-824)  
 (BASIC = STANDARD PERFORMANCE) (HA = HARDENED PERFORMANCE)

### Cutter housing

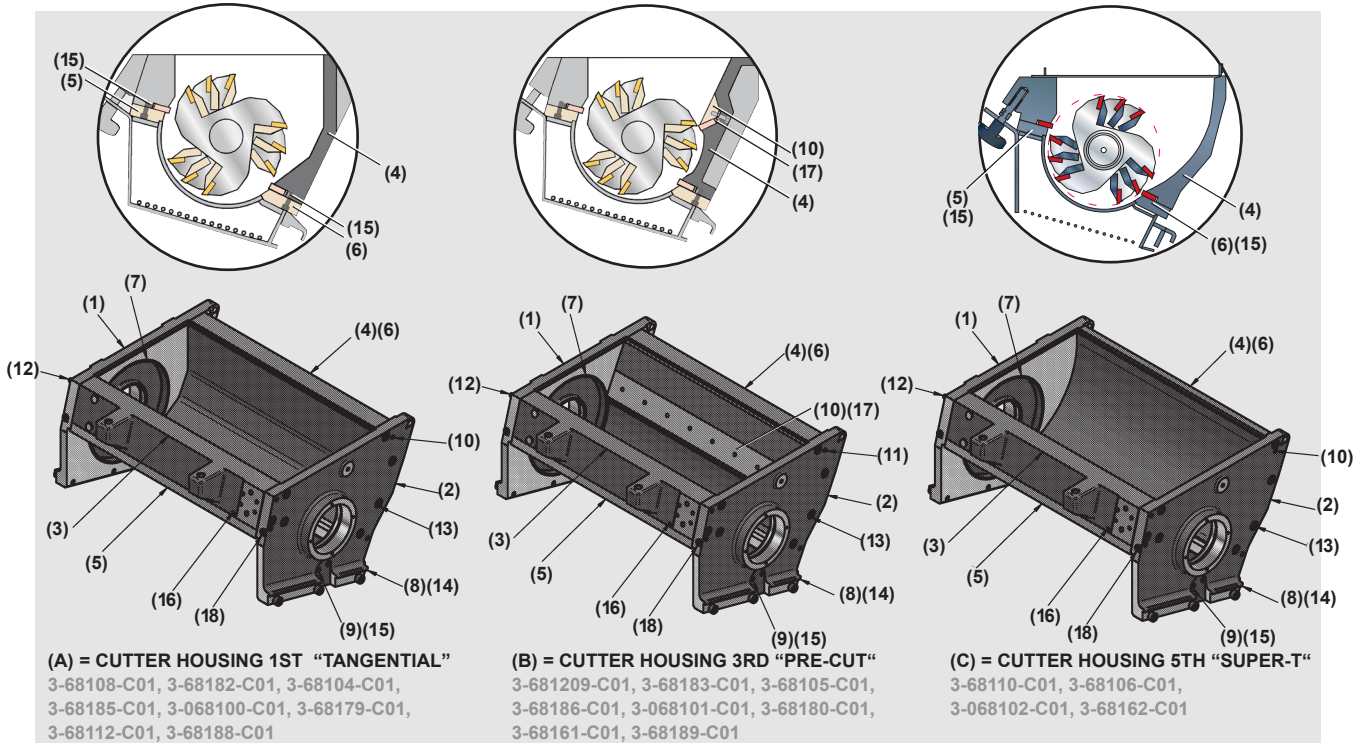

| P        | SE      | FR           | DE           | GB - DETAIL | SPECIFICATION | ART NO   | Q        | M   | V     |
|----------|---------|--------------|--------------|-------------|---------------|----------|----------|-----|-------|
| 4        | BAKSIDA | PARTIE ARRIÉ | SEITE HINTER | BACK SIDE   | CU1ST         | 80068213 | 1        | 810 | BASIC |
|          |         |              |              |             |               | 80068209 | 1        | 814 |       |
|          |         |              |              |             |               | 80068203 | 1        | 819 |       |
|          |         |              |              |             |               | 80068239 | 1        | 824 | HA    |
|          |         |              |              |             |               | 80068487 | 1        | 810 |       |
|          |         |              |              |             |               | 80068491 | 1        | 814 |       |
|          |         |              |              |             |               | 80068483 | 1        | 819 |       |
|          |         |              |              |             |               | 80068495 | 1        | 824 |       |
|          |         |              |              |             |               | CU3RD    | 80068214 | 1   | 810   |
|          |         |              |              |             | 80068210      |          | 1        | 814 |       |
|          |         |              |              |             | 80068204      |          | 1        | 819 |       |
|          |         |              |              |             | 80068242      |          | 1        | 824 | HA    |
|          |         |              |              |             | 80068488      |          | 1        | 810 |       |
|          |         |              |              |             | 80068492      |          | 1        | 814 |       |
|          |         |              |              |             | CU5TH         | 80068484 | 1        | 819 | BASIC |
| 80068496 | 1       | 824          |              |             |               |          |          |     |       |
| 80068215 | 1       | 810          |              |             |               |          |          |     |       |
| 80068211 | 1       | 814          |              |             |               |          |          |     |       |
|          |         |              |              |             |               | 80068205 | 1        | 819 |       |
|          |         |              |              |             |               | 80068241 | 1        | 824 |       |

(CU1ST = CUTTER HOUSING 1ST) (CU1STH = CUTTER HOUSING 1ST HARDENED) (1ST = KNIFE SEAT FIRST) (2ND = KNIFE SEAT 2ND)

(CU3RD = CUTTER HOUSING 3RD) (CU3RDH = CUTTER HOUSING 3RD HARDENED) (3RD = KNIFE SEAT 3RD) (XX = -810, -814, -819, -824)

(BASIC = STANDARD PERFORMANCE) (HA = HARDENED PERFORMANCE)

### Cutter housing

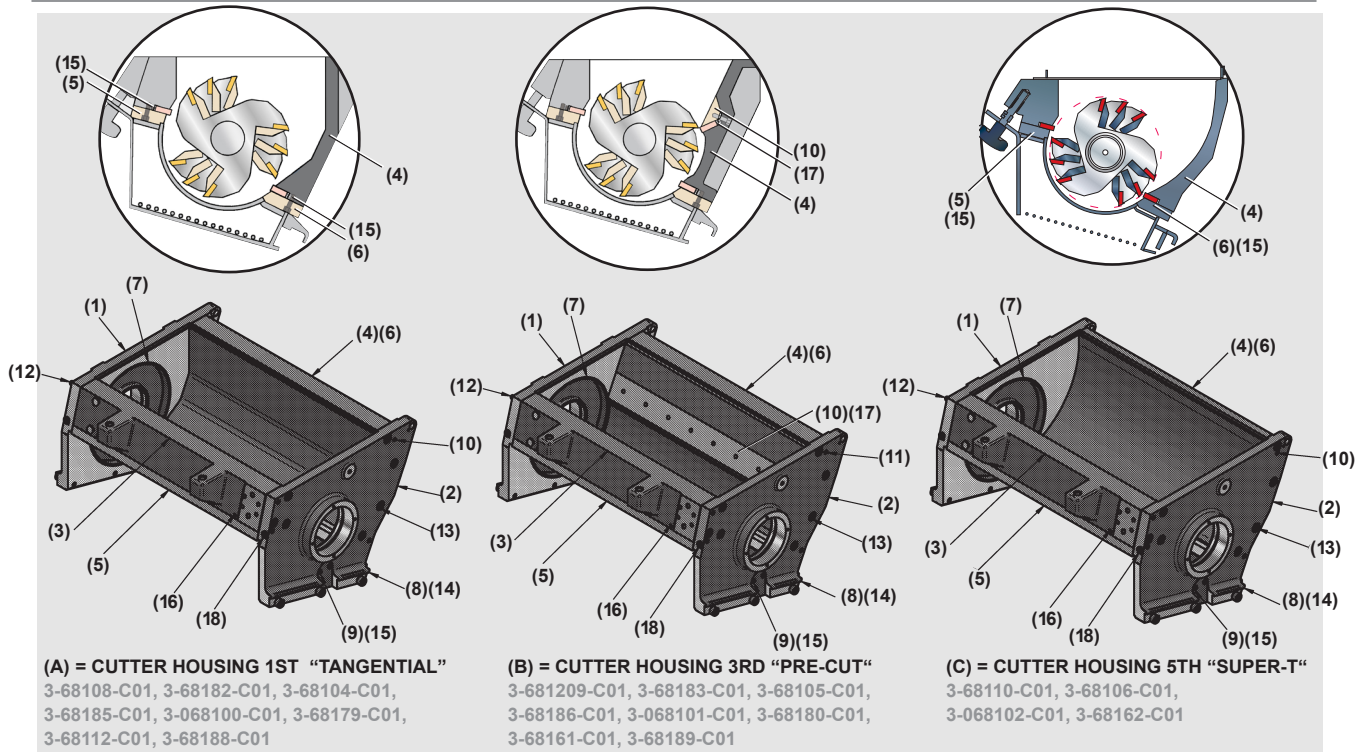

| P   | SE         | FR         | DE          | GB - DETAIL               | SPECIFICATION       | ART NO   | Q  | M   | V     |       |
|---|------------|------------|-------------|---------------------------|---------------------|----------|----|-----|-------|-------|
| 5   | STÖDLINJAL | RÈGLE D'AP | KLEMMLEISTE | SUPPORT RULE              | FRONT HARDENED      | 8430711  | 1  | 810 | ALL   |       |
|   |            |            |             |                           |                     | 8430712  | 1  | 814 |       |       |
|   |            |            |             |                           |                     | 8430713  | 1  | 819 |       |       |
|   |            |            |             |                           |                     | 8244914  | 1  | 824 |       |       |
| 6   | STÖDLINJAL | RÈGLE D'AP | KLEMMLEISTE | SUPPORT RULE              | BACK HARDENED       | 8430708  | 1  | 810 | ALL   |       |
|   |            |            |             |                           |                     | 8430709  | 1  | 814 |       |       |
|   |            |            |             |                           |                     | 8430710  | 1  | 819 |       |       |
|   |            |            |             |                           |                     | 8244915  | 1  | 824 |       |       |
| 7   | RING       | BAUGE      | RING        | RING                      | D=208/200X15 FIXED  | 80068219 | 2  | XX  | ALL   |       |
| 8   | STÖD       | SUPPORT    | ABSTÜTZUN   | SUPPORT                   |                     | 80068218 | 1  | XX  |       |       |
| 9   | LOCK       | COUVERCLE  | DECKEL      | COVER                     |                     | 80068237 | 2  | XX  |       |       |
| 10  | STÖDLINJAL | RÈGLE D'AP | KLEMMLEISTE | SUPPORT RULE 3RD HARDENED |                     | 8229557  | 1  | 810 | CH3RD |       |
|   |            |            |             |                           |                     | 8229558  | 1  | 814 |       |       |
|   |            |            |             |                           |                     | 8229559  | 1  | 819 |       |       |
|   |            |            |             |                           |                     | 8244918  | 1  | 824 |       |       |
| 11  | SPÄNNSTIFT | GOUPILLE   | SPANNSTIFT  | SPRING PIN                | D=8X32              | 9-50079  | 7  | XX  | ALL   |       |
| 12  | SPÄNNSTIFT | GOUPILLE   | SPANNSTIFT  | SPRING PIN                | D=8X40              | 9-50730  | 1  | XX  |       |       |
| 13  | SKRUV      | VIS        | SCHRAUBE    | SCREW                     | SHS MC6S 10X30-12.9 | 9-40845  | 20 | XX  |       |       |
| 14  | SKRUV      | VIS        | SCHRAUBE    | SCREW                     | SHS MC6S 6X20-12.9  | 9-40104  | 4  | XX  |       |       |
| 15  | SKRUV      | VIS        | SCHRAUBE    | SCREW                     | SHS K6S M5X6 A2T    | 9-41042  | 4  | XX  |       |       |
| 16  | SKRUV      | VIS        | SCHRAUBE    | GRUB SCREW                | P6SS 8X30           | 9-40743  | 4  | XX  |       |       |
| 17  | SKRUV      | VIS        | SCHRAUBE    | GRUB SCREW                | P6SS 8X22           | 9-40742  | 2  | XX  |       | CH3RD |
| 18  | SKRUV      | VIS        | SCHRAUBE    | SCREW                     | SHS MC6S 6X10-12.9  | 9-40213  | 2  | XX  |       | ALL   |
| (CU1ST = CUTTER HOUSING 1ST) (CU1STH = CUTTER HOUSING 1ST HARDENED) (1ST = KNIFE SEAT FIRST) (2ND = KNIFE SEAT 2ND)   |            |            |             |                           |                     |          |    |     |       |       |
| (CU3RD = CUTTER HOUSING 3RD) (CU3RDH = CUTTER HOUSING 3RD HARDENED) (3RD = KNIFE SEAT 3RD) (XX = -810,-814,-819,-824) |            |            |             |                           |                     |          |    |     |       |       |
| (ALL = ALL VARIANTS)  |            |            |             |                           |                     |          |    |     |       |       |

## Staggered rotor

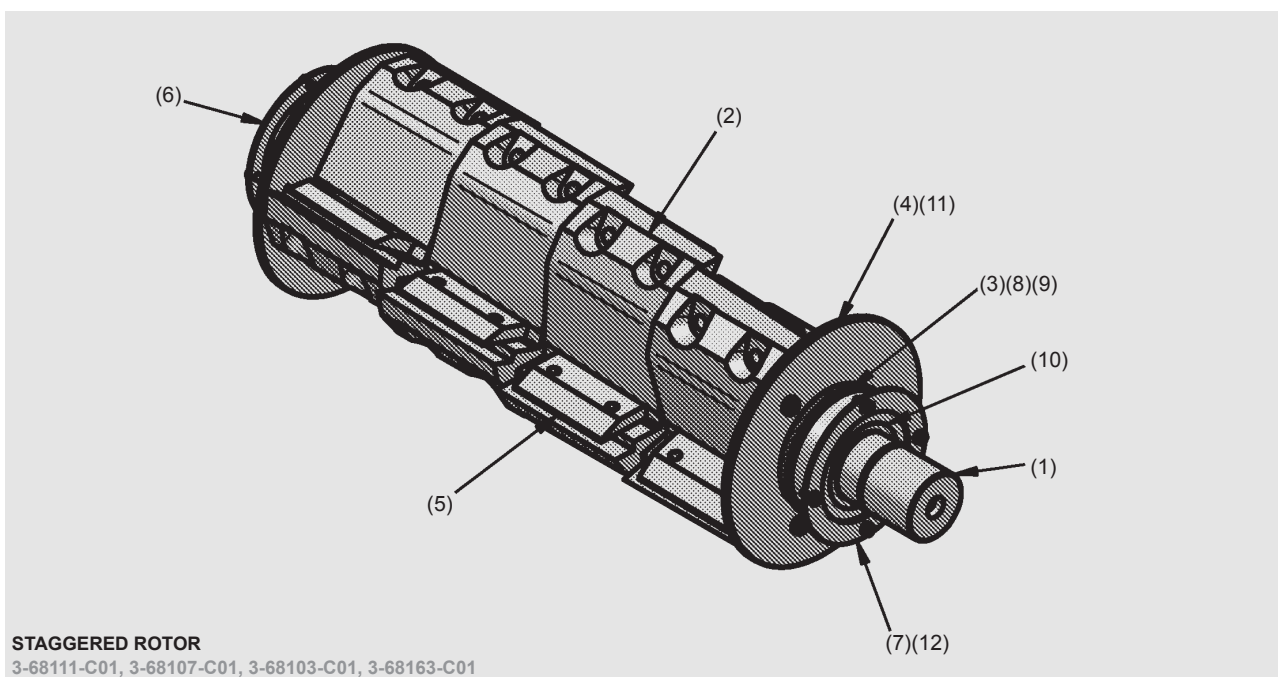

STAGGERED ROTOR

3-68111-C01, 3-68107-C01, 3-68103-C01, 3-68163-C01

| P  | SE                 | FR                        | DE                   | GB - DETAIL          | SPECIFICATION       | ART NO     | Q  | M   | V   |
|----|--------------------|---------------------------|----------------------|----------------------|---------------------|------------|----|-----|-----|
| 1  | KUTTERAXEL         | ARBRE DE ROTOR            | ROTORWELL            | ROTOR SHAFT          |                     | 80068260   | 1  | 810 | ALL |
|    |                    |                           |                      |                      |                     | 80068261   | 1  | 814 |     |
|    |                    |                           |                      |                      |                     | 80068220   | 1  | 819 |     |
|    |                    |                           |                      |                      |                     | 80068262   | 1  | 824 |     |
| 2  | SEGMENT            | SEGMENT                   | SEGMENT              | SEGMENT              |                     | 8129501    | 2  | 810 | ALL |
|    |                    |                           |                      |                      |                     |            | 3  | 814 |     |
|    |                    |                           |                      |                      |                     |            | 4  | 819 |     |
|    |                    |                           |                      |                      |                     |            | 5  | 824 |     |
| 3  | DISTANS KUTTERAXEL | ENTRETOISE ARBRE DE ROTOR | ABSTANDSTÜ ROTORWELL | DISTANCE ROTOR SHAFT |                     | 80068221   | 1  | XX  | ALL |
| 4  | RING               | BAUGE                     | RING                 | RING                 |                     | 8329502    | 2  | XX  |     |
| 5  | STÖDLINJAL         | RÈGLE D'AP                | KLEMMLEISTE          | SUPPORT RULE         | 12X47X9 HA          | 8346410    | 6  | 810 |     |
|    |                    |                           |                      |                      |                     |            | 9  | 814 |     |
|    |                    |                           |                      |                      |                     |            | 12 | 819 |     |
|    |                    |                           |                      |                      |                     |            | 15 | 824 |     |
| 6  | LOCK VÄNSTER       | COUVERCLE                 | DECKEL               | COVER LINKS BLACK    |                     | 8329527-05 | 1  | XX  |     |
| 7  | LOCK HÖGER         | COUVERCLE                 | DECKEL               | COVER RECHT          |                     | 8429528    | 1  | XX  |     |
| 8  | TÄTNINGSRING       | BAGUE D'ÉTANCHÉITÉ        | DICHTUNGS-RING       | SEALING RING         | CR 60X100X10        | 9-60249    | 2  | XX  |     |
| 9  | SPÄRRING           | CIRCLIP, JONC D'ARRÊT     | FÜHRUNGS-RING        | RETAINING RING       | SGH 100             | 9-50895    | 2  | XX  |     |
| 10 | LAGER              | PALIER                    | LAGER                | BEARING 62211-2RS1   | D=100/55X25         | 9-60182    | 2  | XX  |     |
| 11 | SKRUV              | VIS                       | SCHRAUBE             | SCREW                | SHS MC6LS M8X16-8.8 | 9-40579    | 6  | XX  |     |
| 12 | SKRUV              | VIS                       | SCHRAUBE             | SCREW                | SHS MC6S M5X10-12.9 | 9-40071    | 8  | XX  |     |

(XX = -810,-814,-819,-824)

## Open rotor

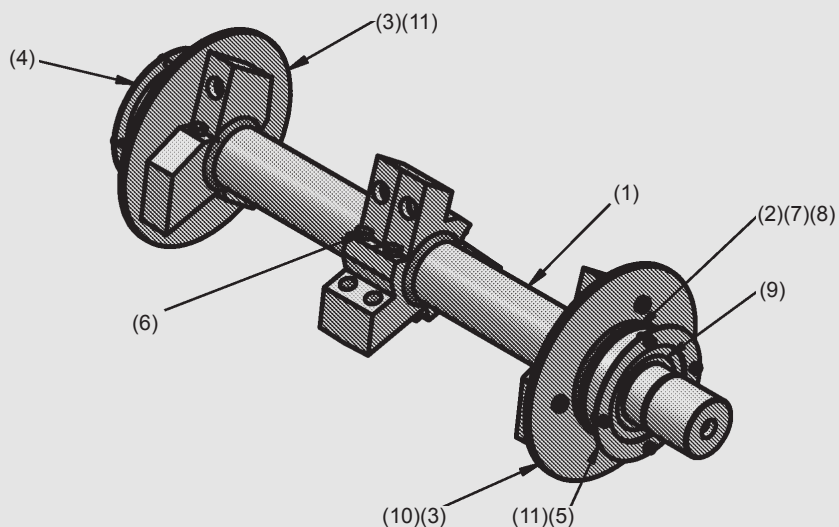

**OPEN ROTOR**

3-68175-C01, 3-68176-C01, 3-68177-C01, 3-68178-C01

| P                          | SE                 | FR                        | DE                   | GB - DETAIL          | SPECIFICATION  | ART NO     | Q  | M   | V   |
|----------------------------|--------------------|---------------------------|----------------------|----------------------|----------------|------------|----|-----|-----|
| 1                          | KUTTERAXEL         | ARBRE DE ROTOR            | ROTORWELL            | ROTOR SHAFT          |                | 80068286   | 1  | 810 | ALL |
|                            |                    |                           |                      |                      |                | 80068288   | 1  | 814 |     |
|                            |                    |                           |                      |                      |                | 80068263   | 1  | 819 |     |
|                            |                    |                           |                      |                      |                | 80068290   | 1  | 824 |     |
| 2                          | DISTANS ROTOR AXEL | ENTRETOISE ARBRE DE ROTOR | ABSTANDSTÜ ROTORWELL | DISTANCE ROTOR SHAFT |                | 80068221   | 1  | XX  |     |
| 3                          | RING               | BAUGE                     | RING                 | RING HARDED          |                | 8430249    | 2  | XX  |     |
| 4                          | LOCK V             | COUVERCLE G               | DECKEL L             | COVER L BLACK        |                | 8329527-05 | 1  | XX  |     |
| 5                          | LOCK H             | COUVERCLE D               | DECKEL R             | COVER R              |                | 8429528    | 1  | XX  |     |
| 6                          | SKRUV              | VIS                       | SCHRAUBE             | ADJUSTING SCREW      | M8X14          | 8443263    | 12 | XX  |     |
| 7                          | TÄTNINGSRING       | BAGUE D'ÉTANCHÉITÉ        | DICHTUNGS-RING       | SEALING RING         | CR 60X100X10   | 9-60249    | 2  | XX  |     |
| 8                          | SPÄRRING           | CIRCLIP, JONC D'ARRÊT     | FÜHRUNGS-RING        | RETAINING RING       | SGH 100        | 9-50895    | 2  | XX  |     |
| 9                          | LAGER              | PALIER                    | LAGER                | BEARING              | 62211-2RS1     | 9-60182    | 2  | XX  |     |
| 10                         | SKRUV              | VIS                       | SCHRAUBE             | SCREW                | SHS MC6LS 8X16 | 9-40579    | 6  | XX  |     |
| 11                         | SKRUV              | VIS                       | SCHRAUBE             | SCREW                | SHS MC6S 5X10  | 9-40071    | 8  | XX  |     |
| (XX = -810,-814,-819,-824) |                    |                           |                      |                      |                |            |    |     |     |

## Knives for a staggered rotor

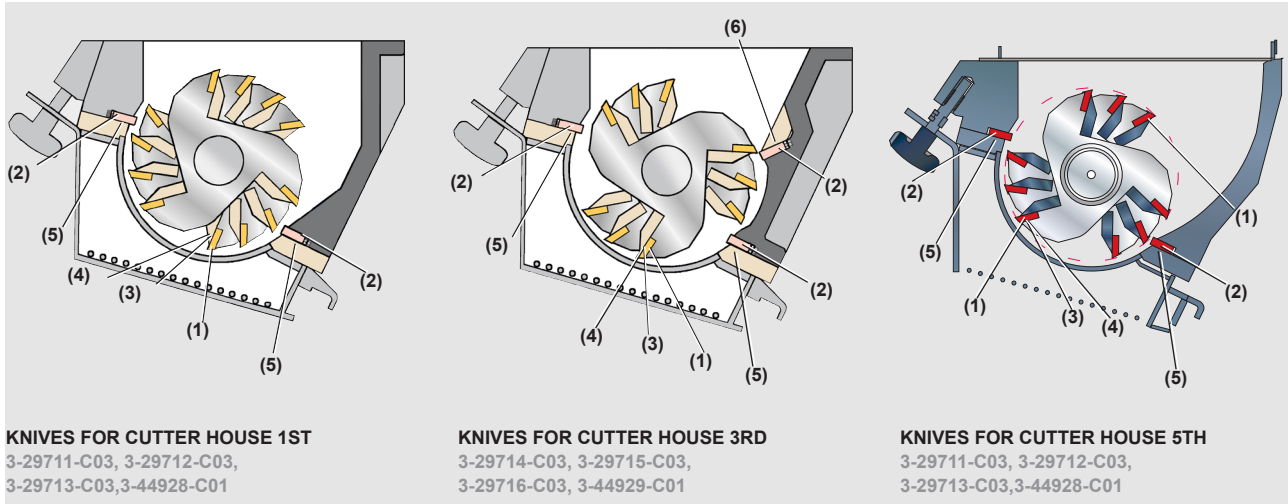

**KNIVES FOR CUTTER HOUSE 1ST**  
3-29711-C03, 3-29712-C03,  
3-29713-C03,3-44928-C01

**KNIVES FOR CUTTER HOUSE 3RD**  
3-29714-C03, 3-29715-C03,  
3-29716-C03, 3-44929-C01

**KNIVES FOR CUTTER HOUSE 5TH**  
3-29711-C03, 3-29712-C03,  
3-29713-C03,3-44928-C01

| P | SE                     | FR                             | DE                       | GB - DETAIL             | SPECIFICATION                               | ART NO  | Q  | M   | V                |
|---|------------------------|--------------------------------|--------------------------|-------------------------|---|---------|----|-----|------------------|
| 1 | KNIV, KUTTER 3<br>BLAD | COUPEAU,<br>ROTOR À 3<br>LAMES | MESSER,<br>3-BLATT-ROTOR | KNIFE, ROTOR 3<br>BLADE |   | 8329503 | 6  | 810 | ALL              |
|   |                        |                                |                          |                         |   |         | 9  | 814 |                  |
|   |                        |                                |                          |                         |   |         | 12 | 819 |                  |
|   |                        |                                |                          |                         |   |         | 15 | 824 |                  |
| 2 | FAST KNIV              | COUPEAUX FIX                   | STATORMESS               | FIXED KNIFE             | CUTTER HOUSE 1ST<br>AND<br>CUTTER HOUSE 5TH | 8329515 | 2  | 810 | CH1ST +<br>CH5TH |
|   |                        |                                |                          |                         |   | 8329516 | 2  | 814 |                  |
|   |                        |                                |                          |                         |   | 8329517 | 2  | 819 |                  |
|   |                        |                                |                          |                         |   | 8344922 | 4  | 824 |                  |
|   |                        |                                |                          |                         | CUTTER HOUSE 3RD                            | 8329515 | 3  | 810 | CH3RD            |
|   |                        |                                |                          |                         |   | 8329516 | 3  | 814 |                  |
|   |                        |                                |                          |                         |   | 8329517 | 3  | 819 |                  |
|   |                        |                                |                          |                         |   | 8344922 | 6  | 824 |                  |
| 3 | SKRUV                  | VIS                            | SCHRAUBE                 | SCREW                   | SHS MC6S 10X40 EHD                          | 9-40004 | 12 | 810 | ALL              |
|   |                        |                                |                          |                         |   |         | 18 | 814 |                  |
|   |                        |                                |                          |                         |   |         | 24 | 819 |                  |
|   |                        |                                |                          |                         |   |         | 30 | 824 |                  |
| 4 | BRICKA                 | RONDELLE                       | SCHEIBE                  | WASHER                  | BRB HB200 10,5X20X2                         | 9-40907 | 12 | 810 | ALL              |
|   |                        |                                |                          |                         |   |         | 18 | 814 |                  |
|   |                        |                                |                          |                         |   |         | 24 | 819 |                  |
|   |                        |                                |                          |                         |   |         | 30 | 824 |                  |
| 5 | SKRUV                  | VIS                            | SCHRAUBE                 | SCREW                   | SHS MC6S 8X25 EHD                           | 9-40778 | 8  | 810 | ALL              |
|   |                        |                                |                          |                         |   |         | 12 | 814 |                  |
|   |                        |                                |                          |                         |   |         | 16 | 819 |                  |
|   |                        |                                |                          |                         |   |         | 20 | 824 |                  |
| 6 | SKRUV                  | VIS                            | SCHRAUBE                 | SCREW                   | SHS MC6S 8X30 EHD                           | 9-40779 | 4  | 810 | CH3RD            |
|   |                        |                                |                          |                         |   |         | 6  | 814 |                  |
|   |                        |                                |                          |                         |   |         | 8  | 819 |                  |
|   |                        |                                |                          |                         |   |         | 10 | 824 |                  |

(XX = -810,-814,-819,-824), (CU1ST = CUTTER HOUSING 1ST), (CU3RD = CUTTER HOUSING 3RD), (CU5TH = CUTTER HOUSING 5TH)

## Knives for an open rotor

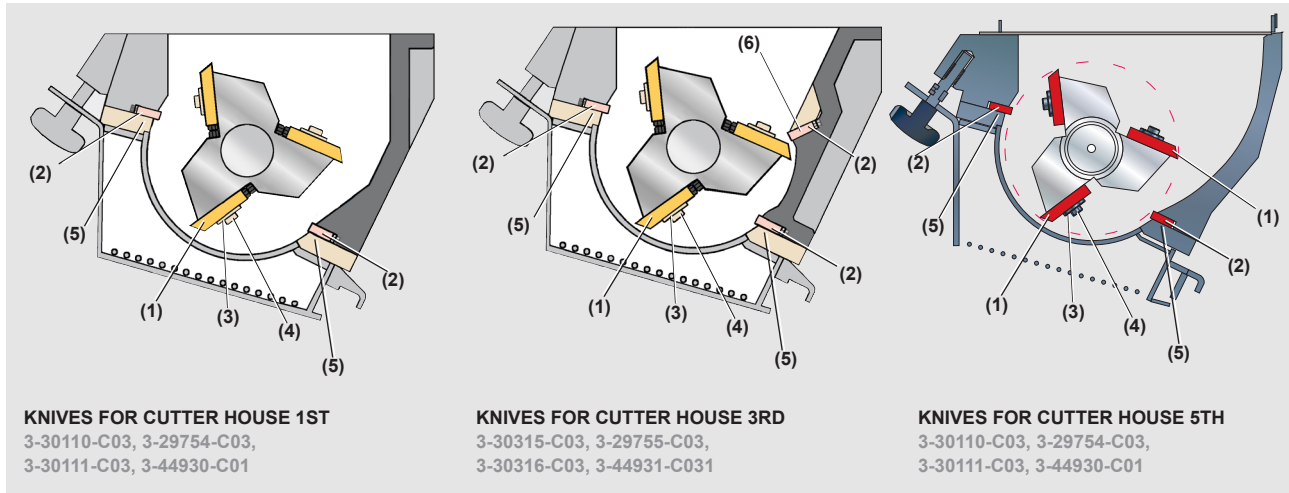

| P  | SE                    | FR                          | DE                          | GB - DETAIL       | SPECIFICATION                               | ART NO  | Q  | M   | V                |  |                  |         |   |     |       |
|--|-----------------------|-----------------------------|-----------------------------|-------------------|---|---------|----|-----|------------------|--|------------------|---------|---|-----|-------|
| 1  | KNIV, ÖPPEN<br>KUTTER | COUPEAU,<br>ROTOR<br>OUVERT | MESSER,<br>OFFENER<br>ROTOR | KNIFE, OPEN ROTOR |   | 8330108 | 6  | 810 | ALL              |  |                  |         |   |     |       |
|  |                       |                             |                             |                   |   | 8329750 | 6  | 814 |                  |  |                  |         |   |     |       |
|  |                       |                             |                             |                   |   | 8330109 | 6  | 819 |                  |  |                  |         |   |     |       |
|  |                       |                             |                             |                   |   | 8244923 | 6  | 824 |                  |  |                  |         |   |     |       |
| 2  | FAST KNIV             | COUPEAUX FIX                | STATORMESS                  | FIXED KNIFE       | CUTTER HOUSE 1ST<br>AND<br>CUTTER HOUSE 5TH | 8329515 | 2  | 810 | CH1ST +<br>CH5TH |  |                  |         |   |     |       |
|  |                       |                             |                             |                   |   | 8329516 | 2  | 814 |                  |  |                  |         |   |     |       |
|  |                       |                             |                             |                   |   | 8329517 | 2  | 819 |                  |  |                  |         |   |     |       |
|  |                       |                             |                             |                   |   | 8344922 | 4  | 824 |                  |  |                  |         |   |     |       |
|  |                       |                             |                             |                   |   |         |    |     |                  |  | CUTTER HOUSE 3RD | 8329515 | 3 | 810 | CH3RD |
|  |                       |                             |                             |                   |   |         |    |     |                  |  |                  | 8329516 | 3 | 814 |       |
|  |                       |                             |                             |                   |   |         |    |     |                  |  |                  | 8329517 | 3 | 819 |       |
|  |                       |                             |                             |                   |   |         |    |     |                  |  |                  | 8344922 | 6 | 824 |       |
| 3  | SKRUV                 | VIS                         | SCHRAUBE                    | SCREW             | SHS MC6LS 16X50 EHD                         | 9-40776 | 12 | XX  | ALL              |  |                  |         |   |     |       |
| 4  | BRICKA                | RONDELLE                    | SCHEIBE                     | WASHER            |   | 8429751 | 12 | XX  | ALL              |  |                  |         |   |     |       |
| 5  | SKRUV                 | VIS                         | SCHRAUBE                    | SCREW             | SHS MC6S 8X25 EHD                           | 9-40778 | 8  | 810 | ALL              |  |                  |         |   |     |       |
|  |                       |                             |                             |                   |   |         | 12 | 814 |                  |  |                  |         |   |     |       |
|  |                       |                             |                             |                   |   |         | 16 | 819 |                  |  |                  |         |   |     |       |
|  |                       |                             |                             |                   |   |         | 20 | 824 |                  |  |                  |         |   |     |       |
| 6  | SKRUV                 | VIS                         | SCHRAUBE                    | SCREW             | SHS MC6S 8X30 EHD                           | 9-40779 | 4  | 810 | CH3RD            |  |                  |         |   |     |       |
|  |                       |                             |                             |                   |   |         | 6  | 814 |                  |  |                  |         |   |     |       |
|  |                       |                             |                             |                   |   |         | 8  | 819 |                  |  |                  |         |   |     |       |
|  |                       |                             |                             |                   |   |         | 10 | 824 |                  |  |                  |         |   |     |       |
| (XX = -810,-814,-819,-824), (CU1ST = CUTTER HOUSING 1ST), (CU3RD = CUTTER HOUSING 3RD), (CU5TH = CUTTER HOUSING 5TH) |                       |                             |                             |                   |   |         |    |     |                  |  |                  |         |   |     |       |

## Screen

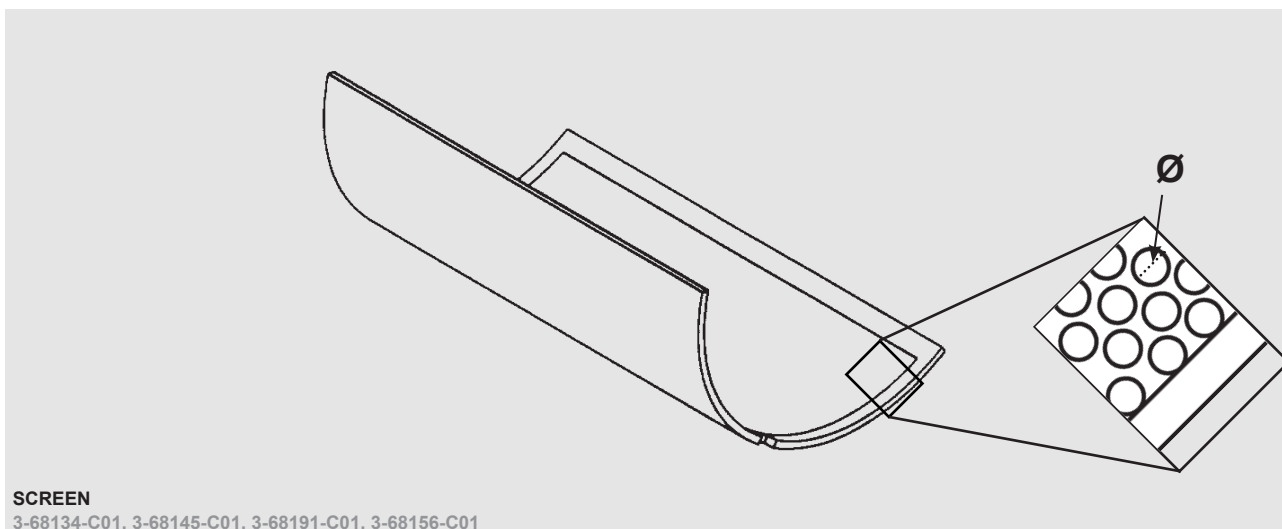

### SCREEN

3-68134-C01, 3-68145-C01, 3-68191-C01, 3-68156-C01

| Screen  |   |            |            |            |            |
|---------|---|------------|------------|------------|------------|
| M       | Ø | 4 mm       | 5 mm       | 6 mm       | 8 mm       |
| NCF-810 |   | 8329574-04 | 8329574-05 | 8329574-06 | 8329574-08 |
| NCF-814 |   | 8329575-04 | 8329575-05 | 8329575-06 | 8329575-08 |
| NCF-819 |   | 8329576-04 | 8329576-05 | 8329576-06 | 8329576-08 |
| NCF-824 |   | 8346065-04 | 8346065-05 | 8346065-06 | 8346065-08 |

| Screen hardened |   |             |             |             |             |
|-----------------|---|-------------|-------------|-------------|-------------|
| M               | Ø | 4 mm        | 5 mm        | 6 mm        | 8 mm        |
| NCF-810         |   | 8430251-04N | 8430251-05N | 8430251-06N | 8430251-08N |
| NCF-814         |   | 8430252-04N | 8430252-05N | 8430252-06N | 8430252-08N |
| NCF-819         |   | 8430253-04N | 8430253-05N | 8430253-06N | 8430253-08N |
| NCF-824         |   | 8448238-04N | 8448238-05N | 8448238-06N | 8448238-08N |

| Screen stitch reduced |   |            |            |            |
|-----------------------|---|------------|------------|------------|
| M                     | Ø | 4 mm       | 5 mm       | 6 mm       |
| NCF-810               |   | 8331688-04 | 8331688-05 | 8331688-06 |
| NCF-814               |   | 8331689-04 | 8331689-05 | 8331689-06 |
| NCF-819               |   | 8431693-04 | 8431693-05 | 8431693-06 |
| NCF-824               |   | 8348239-04 | 8348239-05 | 8348239-06 |

| Screen stitch reduced hardened |   |             |             |             |
|--------------------------------|---|-------------|-------------|-------------|
| M                              | Ø | 4 mm        | 5 mm        | 6 mm        |
| NCF-810                        |   | 8431691-04N | 8431691-05N | 8431691-06N |
| NCF-814                        |   | 8431692-04N | 8431692-05N | 8431692-06N |
| NCF-819                        |   | 8431693-04N | 8431693-05N | 8431693-06N |
| NCF-824                        |   | 8448240-04N | 8448240-05N | 8448240-06N |

## Screen box

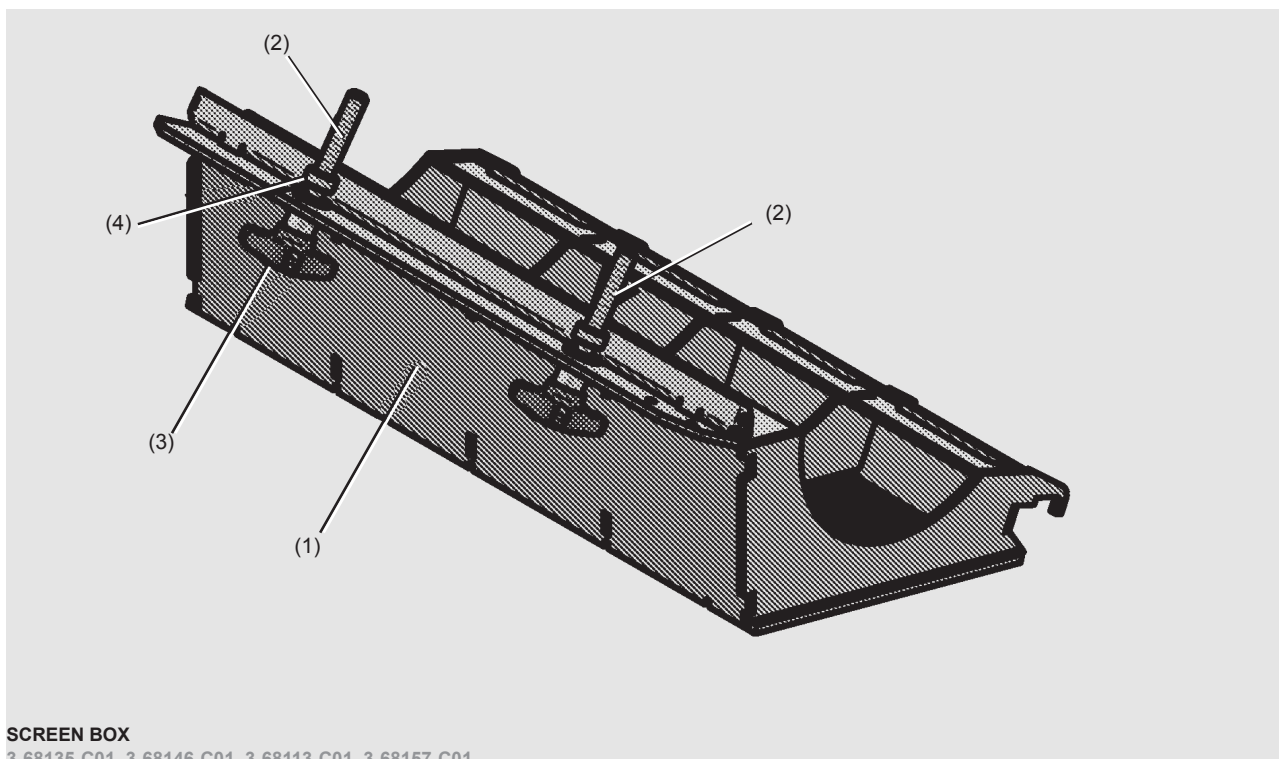

**SCREEN BOX**

3-68135-C01, 3-68146-C01, 3-68113-C01, 3-68157-C01

| P                          | SE                  | FR                                  | DE                    | GB - DETAIL                   | SPECIFICATION         | ART NO   | Q | M   | V   |
|----------------------------|---------------------|-------------------------------------|-----------------------|-------------------------------|-----------------------|----------|---|-----|-----|
| 1                          | SKYDD<br>GALLERLÅDA | PROTECTION,<br>BOÎTE DE<br>TAMISAGE | SCHUTZ,<br>SIEBKASTEN | SCREEN BOX<br>PROTECTIVE GRID |                       | 80068381 | 1 | 810 | ALL |
|                            |                     |                                     |                       |                               |                       | 80068388 | 1 | 814 |     |
|                            |                     |                                     |                       |                               |                       | 80068222 | 1 | 819 |     |
|                            |                     |                                     |                       |                               |                       | 80068341 | 1 | 824 |     |
| 2                          | LÅSBULT             | BOULON VERR                         | SPERRBOLZEN           | LOCKING BOLT                  | M12X107               | 80068517 | 1 | XX  |     |
| 3                          | STJÄRNVRED          | POIGNÉE ÉTOIL                       | STERNGRIFF            | STAR KNOB                     | GN 6335.1 E63-M12 INV | 9-50532  | 2 | XX  |     |
| 4                          | BRICKA              | RONDELLE                            | SCHEIBE               | WASHER                        | BRFB 13X24X2,5        | 9-40816  | 4 | XX  |     |
| (XX = -810,-814,-819,-824) |                     |                                     |                       |                               |                       |          |   |     |     |

## Granule bin, Outlet pipe

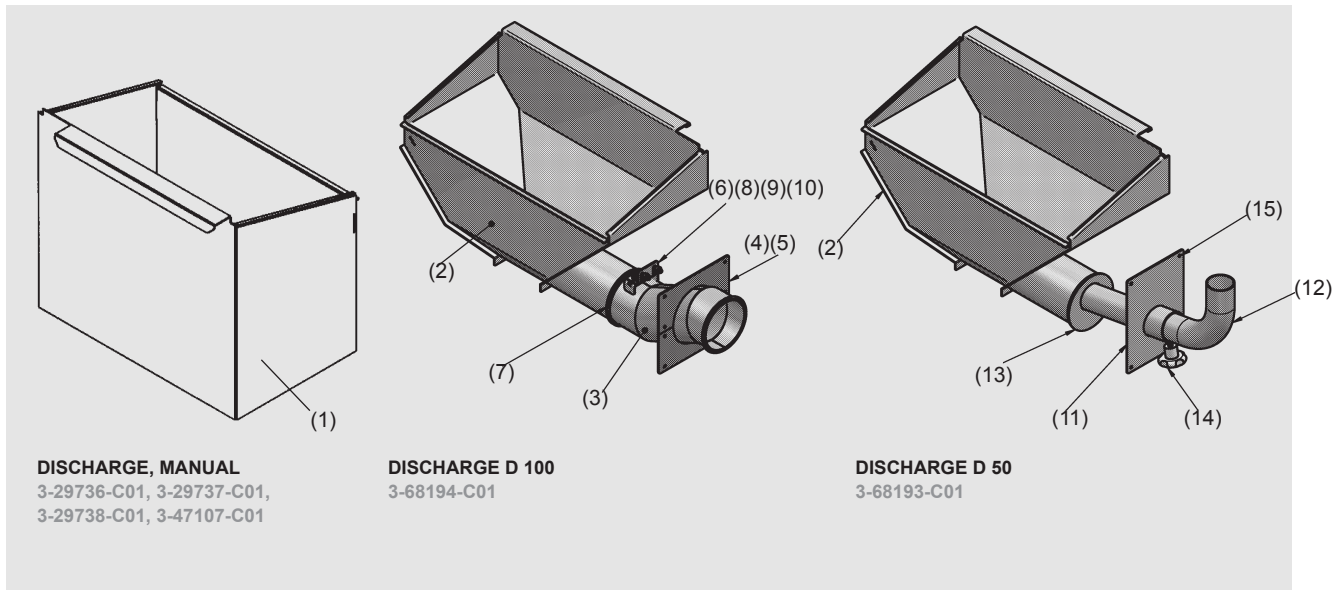

**DISCHARGE, MANUAL**  
3-29736-C01, 3-29737-C01,  
3-29738-C01, 3-47107-C01

**DISCHARGE D 100**  
3-68194-C01

**DISCHARGE D 50**  
3-68193-C01

| P  | SE                                      | FR                                       | DE  | GB - DETAIL                   | SPECIFICATION       | ART NO   | Q | M   | V                 |
|----|---|--|---|-------------------------------|---------------------|----------|---|-----|-------------------|
| 1  | UTMATNING,<br>GRANULAT-<br>LÅDA MANUELL | ALIMENTATION,<br>BAC À MATIÈRE À<br>MAIN | AUSLASS,<br>MAHLGUT-<br>KASTEN<br>MANUELL | OUTLET, MANUAL<br>GRANULE BIN |                     | MF329736 | 1 | XX  | M                 |
|    |   |  |   |                               |                     | MF329737 | 1 | XX  |                   |
|    |   |  |   |                               |                     | MF329738 | 1 | XX  |                   |
|    |   |  |   |                               |                     | MF347107 | 1 | XX  |                   |
| 2  | GRANULAT-<br>LÅDA                       | BAC À MATIÈRE                            | MAHLGUT-<br>KASTEN                        | GRANULE BIN                   |                     | *        | 1 | 810 | D 100<br>D 50     |
|    |   |  |   |                               |                     | *        | 1 | 814 |                   |
|    |   |  |   |                               |                     | 8130087  | 1 | 819 |                   |
|    |   |  |   |                               |                     | *        | 1 | 824 |                   |
| 3  | STOS UTLOPP                             | RACCORD DE<br>SORTIE                     | STUTZEN,<br>AUSLASS                       | FLANGE OUTLET                 | D = 100             | 80068498 | 1 | XX  | D 100, BD,<br>BDE |
|    |   |  |   |                               |                     | 80068459 |   | XX  | D 100, BA         |
| 4  | TÄCKPLÅT                                | PLAQUE                                   | BLECH                                     | COVER PLATE                   | D = 100             | 80068499 | 2 | XX  | D 100, BDE        |
| 5  | POP-NIT                                 | RIVET                                    | NIET                                      | POP-RIVERT                    | STEAL 4,8X10.9      | 9-40432  | 8 | XX  |                   |
| 6  | HÅLLARE STOS                            | FIXATION<br>RACCORD                      | FLANSCH-<br>HALTER                        | HOLDER FLANGE                 |                     | 80068461 | 1 | XX  |                   |
| 7  | SNABBKOPP-<br>LINGSRING                 | BAGUE DE<br>RACORD RAPIDE                | SNELLKUPP-<br>LUNGSRING                   | QUICK COUPLING                | D=100               | 9-20415  | 1 | XX  | D 100             |
| 8  | SKRUV                                   | VIS                                      | SCHRAUBE                                  | SCREW                         | SHS MC6S M6X10-12.9 | 9-40104  | 2 | XX  |                   |
| 9  | SKRUV                                   | VIS                                      | SCHRAUBE                                  | SCREW                         | SHS MC6S M6X20-12.9 | 9-40213  | 2 | XX  |                   |
| 10 | MUTTER                                  | ÉCROU                                    | MUTTER                                    | NUT                           | LOC-KING M6-A2      | 9-40591  | 2 | XX  |                   |
| 11 | FÄSTE                                   | FIXATION                                 | BEFESTIGUN                                | BRACKET                       | D = 50              | 7230248  | 1 | XX  | D 50              |
| 12 | RÖR                                     | TUYAU                                    | ROHR                                      | PIPE                          | D = 50/46 80^       | 8329752  | 1 | XX  | D 50, BD          |
|    |   |  |   |                               |                     | 8330078  | 1 | XX  | D 50, BDE         |
| 13 | LOCK                                    | COUVERCLE                                | DECKEL                                    | COVER                         | D = 110/52          | 8430077  | 1 | XX  |                   |
| 14 | STJÄRNVRED                              | POIGNÉE ÉTOIL                            | STERNGRIF                                 | STAR KNOB WN450               | 50-M8X15            | 9-50095  | 1 | XX  | D 50              |
| 15 | POP-NIT                                 | RIVET                                    | NIET                                      | POP-RIVERT                    | STEEL D 4,8X10,9    | 9-40432  | 4 | XX  |                   |

(M = MANUEL DISCHARGE) (D 100 = DISCHARGE WITH PIPE DIAMETER 100 MM) (D 50 = DISCHARGE WITH PIPE DIAMETER 50 MM)  
(BD = BLOWER DETACHED) (BDE = BLOWER DETACHED, GRANULATOR ENCLOSED) (BA = BLOWER ATTACHED)  
(XX = -810,-814,-819,-824)

# Blower

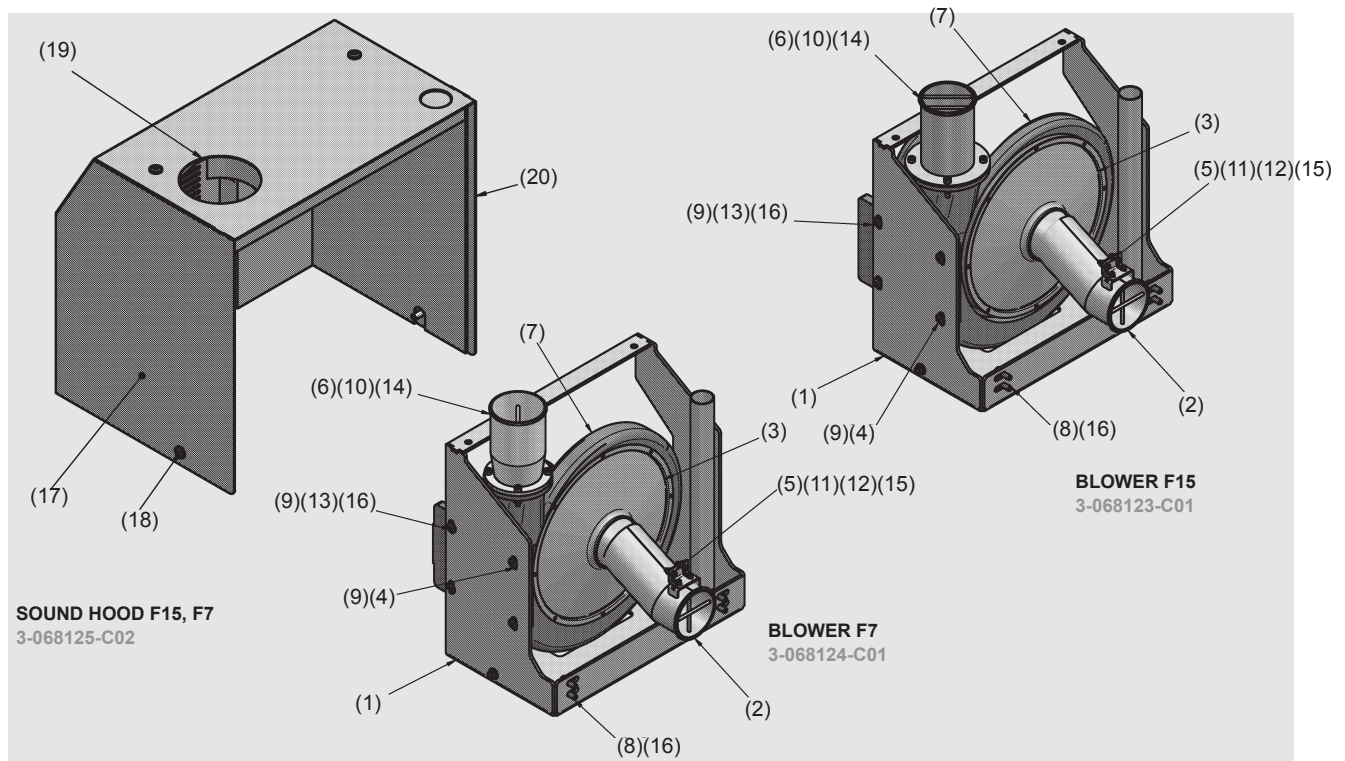

| Blower | Voltage/Frequency |               |           |                                |               |
|--------|-------------------|---------------|-----------|--------------------------------|---------------|
|        | 200-220V/50Hz     | 200-220V/60Hz | 380V/60Hz | 220-240V/50Hz<br>380-420V/50Hz | 440-480V/60Hz |
| F-7    | 920877            | 920878        | 992187    | 920206                         | 992828        |
| F-15   | 920879            | 920880        | 992136    | 920421                         | 992829        |

| P  | SE            | FR                   | DE               | GB - DETAIL                | SPECIFICATION                 | ART NO   | Q | M  | V   |
|----|---------------|----------------------|------------------|----------------------------|-------------------------------|----------|---|----|-----|
| 1  | HÅLLARE       | SUPPORT              | HALTER           | HOLDER F7 F15              |                               | 80068457 | 1 | XX | ALL |
| 2  | STOS          | RACCORD              | STUTZEN          | FLANGE D=100 OK100         |                               | 80068459 | 1 | XX |     |
| 3  | STOS INLOPP   | RACCOR D'ENTRÉE      | STUTZEN, EINLASS | FLANGE INLET               | D=374/101X35                  | 8330267  | 1 | XX |     |
| 4  | HÅLLARE FLÄKT | FIXATION VENTILATEUR | GEBLÄSEHALTER    | HOLDER BLOWER F7/F15 BLACK |                               | 8424655  | 1 | XX |     |
| 5  | HÅLLARE STOS  | FIXATION RACCORD     | FLANSCHHALTER    | HOLDER FLANGE              |                               | 80068461 | 1 | XX |     |
| 6  | STOS UTLOP    | RACCORD DE SORTIE    | STUTZEN, AUSLASS | FLANGE OUTLET              | F15-OK100 L=150               | 8313138  | 1 | XX |     |
|    |               |                      |                  |                            | F7-OK100 L=160                | 8310332  | 1 | XX |     |
| 7  | FLÄKT         | VENTILATEUR          | GEBLÄSE          | GEBLÄSE                    | REFER TO TABLE                |          | 1 | XX |     |
| 8  | SKRUV         | VIS                  | SCHRAUBE         | SCREW                      | SHS MC6S 10X25-12.9 DELTA BLA | 9-41012  | 4 | XX |     |
| 9  | SKRUV         | VIS                  | SCHRAUBE         | SCREW                      | SHS K6SF 10X40-10.9           | 9-41056  | 4 | XX |     |
| 10 | SKRUV         | VIS                  | SCHRAUBE         | SCREW                      | SHS MC6S 8X35-12.9            | 9-40126  | 4 | XX |     |
| 11 | SKRUV         | VIS                  | SCHRAUBE         | SCREW                      | SHS MC6S 6X20-12.9            | 9-40104  | 2 | XX |     |
| 12 | SKRUV         | VIS                  | SCHRAUBE         | SCREW                      | SHS MC6S 6X10-12.9            | 9-40213  | 2 | XX |     |
| 13 | MUTTER        | ÉCROU                | MUTTER           | NUT LOC-KING               | M10-8.8                       | 9-40015  | 2 | XX |     |
| 14 | MUTTER        | ÉCROU                | MUTTER           | NUT LOC-KING               | M8-8.8                        | 9-40317  | 4 | XX |     |
| 15 | MUTTER        | ÉCROU                | MUTTER           | NUT LOC-KING               | M6 A2 STAINLESS               | 9-40951  | 2 | XX |     |
| 16 | BRICKA        | RONDELLE             | SCHEIBE          | WASHER                     | BRB 10,5/22-2 FZB             | 9-40031  | 6 | XX |     |
| 17 | BULLERHUV     | CAPOT ANTI-BRUIT     | SCHALLDÄMMHAUBE  | SOUND HOOD F7, F15         |                               | 80068477 | 1 | XX | ALL |
| 18 | SKRUV         | VIS                  | SCHRAUBE         | SCREW                      | SHS K6SF 10X20-10.9           | 9-41055  | 4 | XX |     |
| 19 | LIST TÄTNING  | BAGUETTE             | LEISTE           | LIST SEALING               | NR. 700310                    | 9-70157  | 1 | XX |     |
| 20 | TAPP          | GOUPILLE             | STIFT            | STUD                       | PS 8X30                       | 940157   | 1 | XX |     |

(XX = -810,-814,-819,-824)

## Transmission

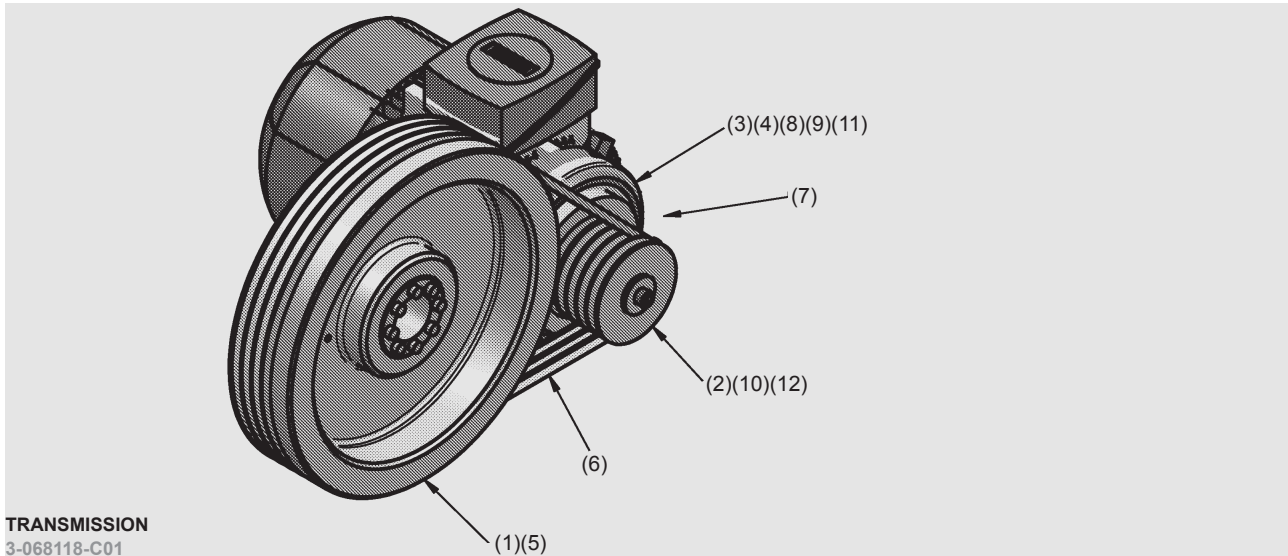

TRANSMISSION  
3-068118-C01

|   |             |             |             |                   | 1                                  | 2                  | 3           | 4                                  |
|---|-------------|-------------|-------------|-------------------|------------------------------------|--------------------|-------------|------------------------------------|
|   | Motor/Start | Motor speed | Rotor speed | V-BELT<br>9-30221 | 200-219V / 50Hz<br>200-220V / 60Hz | 220-240V /<br>50Hz | 380V / 60Hz | 380-420V / 50Hz<br>440-480V / 60Hz |
| A | 4kW/DOL     | 1000        | 260         | 3                 | 9-92801                            | 9-11251-IE2        | 9-92801     | 9-11251-IE2                        |
| B | 5.5kW/DOL   | 1000        | 260         | 3                 | 9-92451                            | 9-11252-IE2        | 9-92451     | 9-11252-IE2                        |
| C | 5.5kW/DOL   | 1500        | 400         | 3                 | 9-92830                            | 9-11240-IE2        | 9-92830     | 9-11240-IE2                        |
| D | 5.5kW/DOL   | 3000        | 840         | 3                 | 9-92717-IE2                        | 9-92501-IE2        | 9-92717-IE2 | 9-92501-IE2                        |
| E | 7.5kW/DOL   | 1500        | 400         | 3                 | 9-92388                            | 9-11173-IE2        | 9-92388     | 9-11173-IE2                        |
| F | 7.5kW/YD    | 1500        | 400         | 3                 | 9-92388                            | 9-11173-IE2        | 9-92738-IE2 | 9-11172-IE2                        |
| G | 7.5kW/DOL   | 3000        | 840         | 3                 | 9-93553-IE2                        |                    | 9-93553-IE2 | 9-92527-IE2                        |
| H | 7.5kW/YD    | 3000        | 840         | 3                 | 9-93553-IE2                        |                    | 9-93330-IE2 | 9-92527-IE2                        |
| J | 11kW/YD     | 1500        | 400         | 4                 | 9-92831                            | 9-11253            | 9-93392-IE2 | 9-11177-IE2                        |
| K | 11kW/YD     | 3000        | 840         | 4                 | 9-93345                            |                    |             | 9-92855-IE2                        |

| P  | SE             | FR                   | DE                | GB - DETAIL       | SPECIFICATION     | ART NO         | Q             | M  | V   |
|----|----------------|----------------------|-------------------|-------------------|-------------------|----------------|---------------|----|-----|
| 1  | REMSKIVA ROTOR | POULIE ROTOR         | RIEMENSCHER ROTOR | PULLEY ROTOR      | 4 SPA 405,5-55    | 9-30233        | 1             | XX | ALL |
| 2  | REMSKIVA MOTOR | POULIE MOTEUR        | RIEMENSCHER MOTOR | PULLEY MOTOR      | 4 SPA 117,5-38    | 9-30234        | 1             | XX |     |
| 3  | REMSTRÄCKARE   | TENDEUR MOTEUR       | RIEMENSCHAN       | BELT STRETCHER    |                   | 80064810       | 2             | XX |     |
| 4  | MOTOR          | MOTEUR               | MOTOR             | MOTOR             |                   | REFER TO TABLE | 1             | XX |     |
| 5  | KLÄMBUSSNING   | COUSSINET DE SERRAGE | KLEMMBUCHSE       | EXPANDING BUSHING | CE06-55           | 9-30222        | 1             | XX |     |
| 6  | KILREM         | COURROIE T           | KEILRIEMEN        | V-BELT            | XPA 1600 LW       | 9-30221        | REF. TO TABLE | XX |     |
| 7  | RING           | BAUGE                | RING              | RING              |                   | 9-70214        | 1             | XX |     |
| 8  | SKRUV          | VIS                  | SCHRAUBE          | SCREW             | HHS M6S 10X35     | 9-40092        | 4             | XX |     |
| 9  | SKRUV          | VIS                  | SCHRAUBE          | SCREW             | HHS M6S 10X140 H. | 9-40744        | 2             | XX |     |
| 10 | SKRUV          | VIS                  | SCHRAUBE          | SCREW             | SHS MC6S 12X30    | 9-40106        | 1             | XX |     |
| 11 | BRICKA         | RONDELLE             | SCHEIBE           | WASHER            | BRB 10,5 FZB      | 9-40031        | 6             | XX |     |
| 12 | BRICKA         | RONDELLE             | SCHEIBE           | WASHER            | 13X49X5 DIN1052   | 9-40648        | 1             | XX |     |

(XX = -810,-814,-819,-824)

# Enclosure

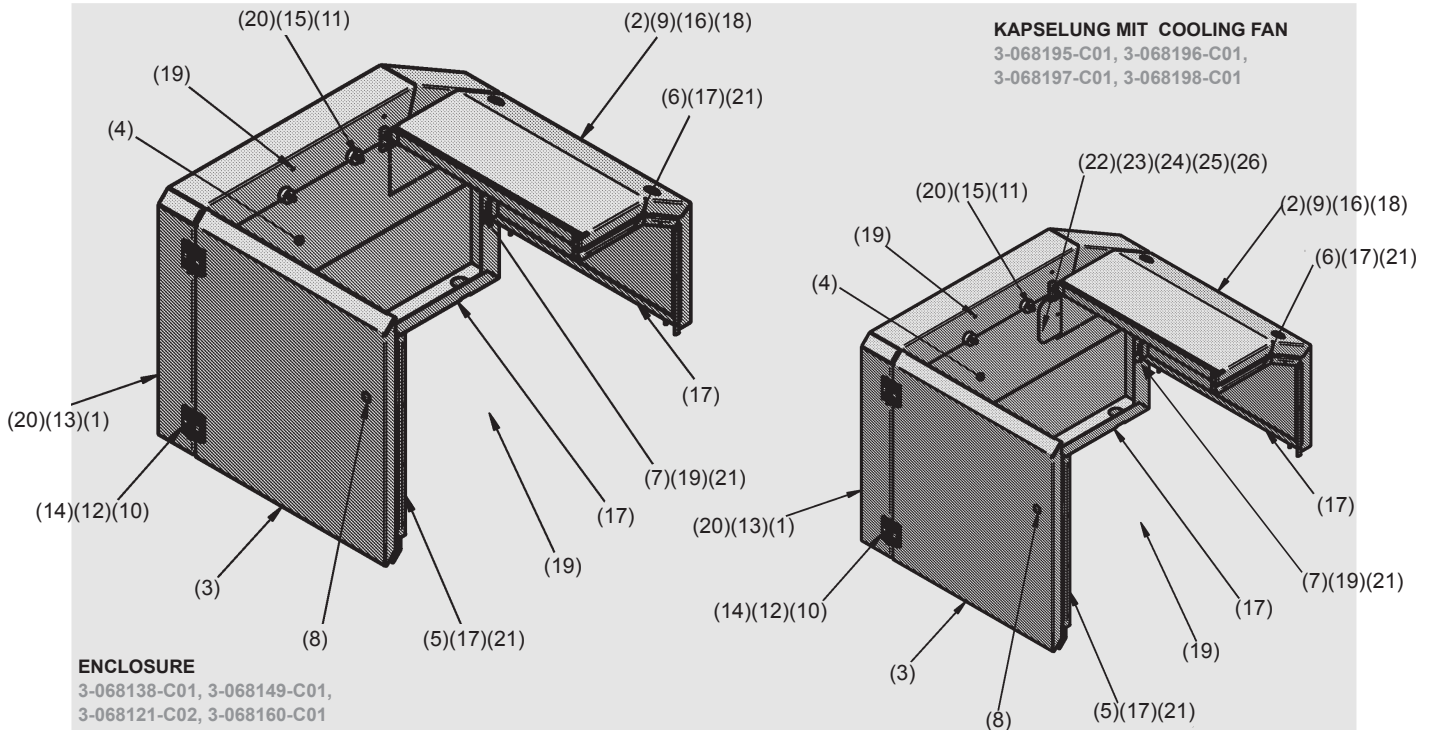

| P  | SE                       | FR                               | DE                           | GB - DETAIL            | SPECIFICATION        | ART NO   | Q | M   | V   |
|----|--------------------------|----------------------------------|------------------------------|------------------------|----------------------|----------|---|-----|-----|
| 1  | KÅPA VÄNSTER             | CAPOT GAUCHE                     | HAUBE LINKS                  | COVER LINKS            |                      | 80068472 |   | XX  |     |
| 2  | KÅPA BAK                 | CAPOT ARRIÈRE                    | HAUBE ZURÜCK                 | COVER BACK             |                      | 80068362 | 1 | 810 |     |
|    |                          |                                  |                              |                        |                      | 80068366 |   | 814 |     |
|    |                          |                                  |                              |                        |                      | 80068476 |   | 819 |     |
|    |                          |                                  |                              |                        |                      | 80068370 |   | 824 |     |
| 3  | DÖRR                     | PORTE                            | TÜR                          | DOOR                   |                      | 80068361 | 1 | 810 |     |
|    |                          |                                  |                              |                        |                      | 80068365 |   | 814 |     |
|    |                          |                                  |                              |                        |                      | 80068450 |   | 819 |     |
|    |                          |                                  |                              |                        |                      | 80068368 |   | 824 |     |
| 4  | ABSORBENT                | AMORTISSEU                       | DÄMPFER                      | ABSORBER KIT ENCLOSURE |                      | 80068451 | 1 | XX  | ALL |
| 5  | HÅLLARE LIST DÖRR        | FIXATION BAGUETTE PORTE          | HALTER TÜR-LEISTE            | HOLDER LIST DOOR       |                      | 80068233 | 1 | XX  |     |
| 6  | HÅLLARE LIST BAK HÖGER   | FIXATION ARRIÈRE BAGUETTE DROITE | HALTER HINTERE LEISTE RECHTS | HOLDER LIST BACK R     |                      | 80068234 | 1 | XX  |     |
| 7  | HÅLLARE LIST BAK VÄNSTER | FIXATION ARRIÈRE BAGUETTE GAUCHE | HALTER HINTERE LEISTE, LINKS | HOLDER LIST BACK L     |                      | 80068235 | 1 | XX  |     |
| 8  | HANDTAG                  | POGNÉE                           | GRIFF                        | HANDLE COMPLETE HIGH   | A=42 L=45 D=22       | 9-94892  | 1 | XX  |     |
| 9  | LÅS                      | VERROU                           | SCHLOSS                      | LOCK DOOR BLACK        | A=42 L=45 D=22,5     | 9-94887  | 2 | XX  |     |
| 10 | GÅNGGÄRN                 | CHARNIÈRE                        | SCHARNIER                    | HINGE METAL BLACK      | 60X606X8             | 9-50640  | 2 | XX  |     |
| 11 | DÄMPARE                  | AMORTISSEU                       | DÄMPFER                      | DAMPER                 | D=30 X 15 M8X15 HR40 | 9-50784  | 2 | XX  |     |
| 12 | SKRUV                    | VIS                              | SCHRAUBE                     | SCREW                  | SHS MF6S M8X25-10.9  | 9-40139  | 8 | XX  |     |
| 13 | SKRUV                    | VIS                              | SCHRAUBE                     | SCREW                  | SHS MC6S M8X20-12.9  | 9-40070  | 2 | XX  | ALL |
| 14 | MUTTER                   | ÉCROU                            | MUTTER                       | NUT BLIND RIVET        | M8X16 0.7-3.0 STEEL  | 9-50196  | 8 | XX  |     |
| 15 | MUTTER                   | ÉCROU                            | MUTTER                       | NUT LOC-KING           | M8-8.8               | 9-40317  | 2 | XX  |     |
| 16 | HANDTAG INFÄLLT          | POGNÉE                           | GRIFF                        | HANDLE P2-53 SOUTHCO   |                      | 9-50757  | 1 | XX  |     |

(XX = -810, -814, -819, -824)

### Enclosure

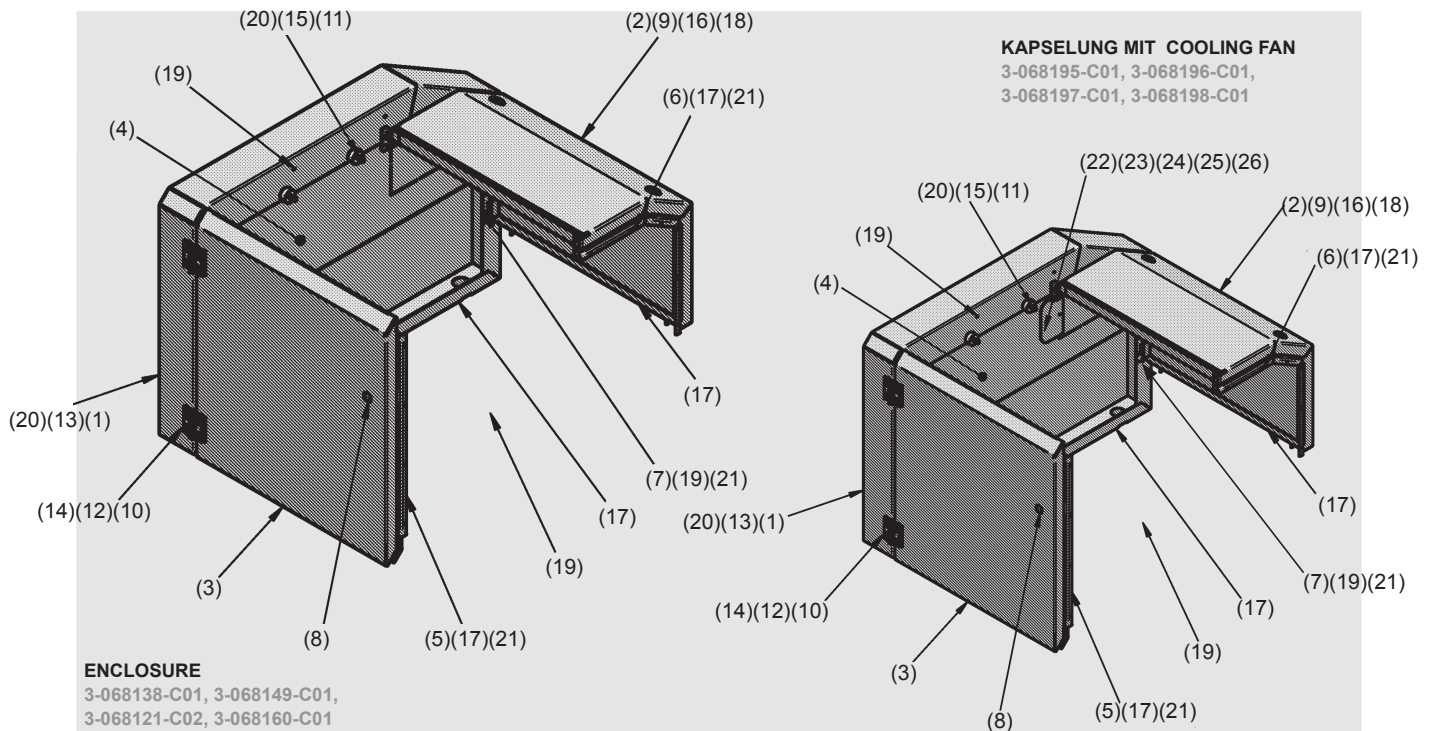

| P  | SE      | FR          | DE         | GB - DETAIL        | SPECIFICATION             | ART NO   | Q  | M  | V   |
|----|---------|-------------|------------|--------------------|---------------------------|----------|----|----|-----|
| 17 | LIST    | BAGUETTE    | LEISTE     | LIST CELLO         | 10X6                      | 9-70345  | 1  | XX | ALL |
| 18 | LIST    | BAGUETTE    | LEISTE     | LIST SEALING       | 30X35 NR. 700090          | 9-94890  | 1  | XX |     |
| 19 | LIST    | BAGUETTE    | LEISTE     | LIST SELF-ADHESIVE | 15X8 EPDM                 | 9-70218  | 1  | XX |     |
| 20 | BRICKA  | RONDELLE    | SCHEIBE    | WASHER BODY        | 8,4X24X2 FZB              | 9-40592  | 4  | XX |     |
| 21 | POP-NIT | RIVET       | NIET       | POP-RIVET          | ALUMINIUM D 4,8X10.9      | 9-40261  | 23 | XX | F   |
| 22 | FÄSTE   | FIXATION    | BEFESTIGUN | BRACKET            | GEBLÄSE                   | 80068523 | 1  | XX |     |
| 23 | FLÄKT   | VENTILATEUR | GEBLÄSE    | BLOWER             | ELECTRONIC 24 V DC 7415FS | 9-92593  | 1  | XX |     |
| 24 | SKRUV   | VIS         | SCHRAUBE   | SCREW              | SHS MC6S                  | 9-40457  | 4  | XX |     |
| 25 | MUTTER  | ÉCROU       | MUTTER     | NUT                | LOC-KING                  | 9-40315  | 4  | XX |     |
| 26 | BRICKA  | RONDELLE    | SCHEIBE    | WASHER             | BRB ISO7089               | 9-40244  | 4  | XX |     |

(XX = -810,-814,-819,-824) (F = ENCLOSUR WITH FAN)

## Body

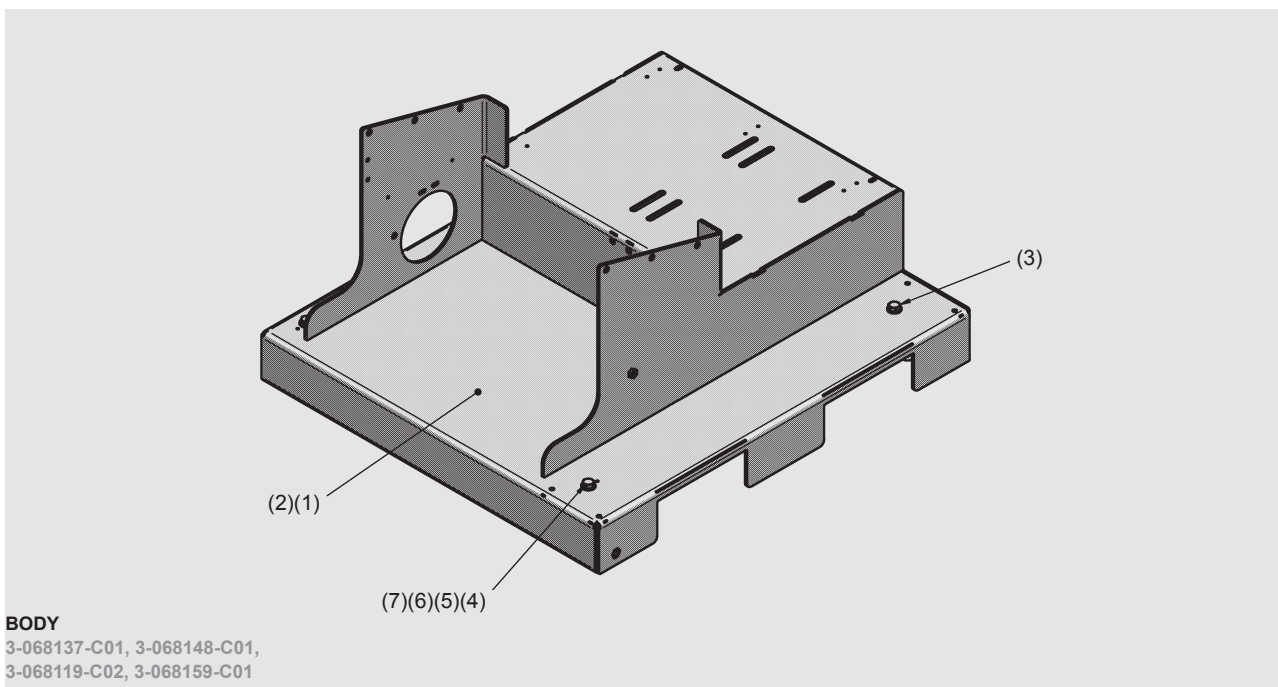

**BODY**  
3-068137-C01, 3-068148-C01,  
3-068119-C02, 3-068159-C01

| P                          | SE         | FR             | DE         | GB - DETAIL       | SPECIFICATION     | ART NO   | Q | M   | V   |
|----------------------------|------------|----------------|------------|-------------------|-------------------|----------|---|-----|-----|
| 1                          | BOTTENPLÅT | PLAQUE DE FOND | BODENPLATT | BOTTOM PLATE      |                   | 80068242 | 1 | 810 | ALL |
|                            |            |                |            |                   |                   | 80068245 | 1 | 814 |     |
|                            |            |                |            |                   |                   | 80068443 | 1 | 819 |     |
|                            |            |                |            |                   |                   | 80068248 | 1 | 824 |     |
| 2                          | ABSORBENT  | AMORTISSEU     | DÄMPFER    | ABSORBER KIT BODY |                   | 80068257 | 1 | 810 |     |
|                            |            |                |            |                   |                   | 80068258 | 1 | 814 |     |
|                            |            |                |            |                   |                   | 80068256 | 1 | 819 |     |
|                            |            |                |            |                   |                   | 80068259 | 1 | 824 |     |
| 3                          | HJUL       | ROULETTE       | RAD        | CASTOR SD4-75-821 | D=75              | 9-50147  | 2 | XX  |     |
| 4                          | HJUL       | ROULETTE       | RAD        | CASTOR SR4-75-821 | D=75              | 9-50148  | 2 | XX  |     |
| 5                          | SKRUV      | VIS            | SCHRAUBE   | SCREW             | HHS M6S 12X30-8.8 | 9-40306  | 4 | XX  |     |
| 6                          | MUTTER     | ÉCROU          | MUTTER     | NUT LOC-KING      | M12 LOW DIN 985   | 9-40847  | 4 | XX  |     |
| 7                          | BRICKA     | RONDELLE       | SCHEIBE    | WASHER            | BRB 13,0/24-2     | 9-40155  | 4 | XX  |     |
| (XX = -810,-814,-819,-824) |            |                |            |                   |                   |          |   |     |     |

Options

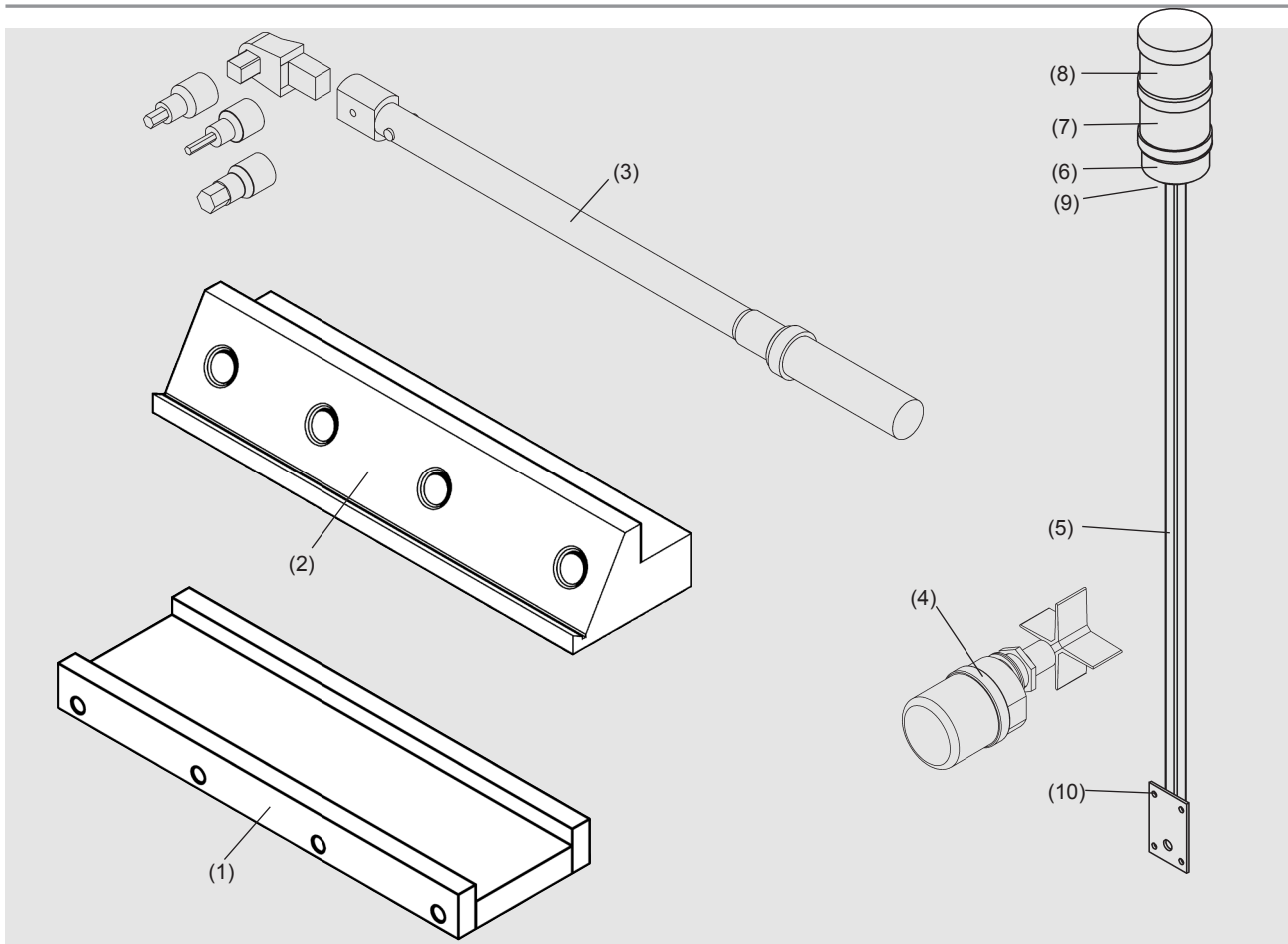

| P  | SE                     | FR                                 | DE                        | GB - DETAIL               | SPECIFICATION | ART NO   | Q | M             | V   |
|----|------------------------|------------------------------------|---------------------------|---------------------------|---------------|----------|---|---------------|-----|
| 1  | KNIVINSTÄLLNINGSFIXTUR | DISPOSITIF D' RÉGLAGE DES COUTEAUX | MESSEREINSTELLVORRICHTUNG | KNIFE SETTING FIXTURE     |               | MF330319 | 1 | 810, 814, 819 | ALL |
|    |                        |                                    |                           |                           |               | MF330324 | 1 | 60            |     |
| 2  | KNIVSLIPNINGSFIXTUR    | DISPOSITIF D' AFFÛTAGE             | SCHLEIVORRICHTUNG         | GRINDING FIXTURE          |               | MM330324 | 1 | XX            |     |
| 3  | MOMENTNYCKELSATS       | KIT CLÉ DYNAMOMÉTRIQUE             | DREHMOMENT-SCHÜSSELSATZ   | TORQUE WRENCH KIT         | 20-200 NM     | MM339559 | 1 | XX            | OC  |
|    |                        |                                    |                           |                           | 40-340 NM     | MM339563 | 1 | XX            | SC  |
| 4  | PADDELVAKT             | TÉMOIN À PALETTE                   | PADDELWÄCHTER             | PADDLE SWITCH             |               | *        | 1 | XX            | ALL |
| 5  | HÅLLARE VARNINGS-LAMPA | SUPPORT                            | HALTER                    | HOLDER WARNING LAMP BLACK |               | 8240465  | 1 | XX            | ALL |
| 6  | FÄSTE                  | FIXATION                           | BEFESTIGUN                | BRACKET WARNING LAMP      |               | 9-12312  | 1 | XX            |     |
| 7  | VARNINGS-LAMPA         | LAMP D' AVERTISSEMENT              | WARNLAMPE                 | WARNING LAMP              | BLINK SDA 24V | 9-12310  | 1 | XX            |     |
| 8  | SUMMER                 | BIPEUR                             | SUMMER                    | BUZZER                    | SDE 24V AUER  | 9-12311  | 1 | XX            |     |
| 9  | SKRUV                  | VIS                                | SCHRAUBE                  | SCREW                     | SHS MC6S 4X30 | 9-40547  | 2 | XX            |     |
| 10 | SKRUV                  | VIS                                | SCHRAUBE                  | SCREW                     | SHS K6S 5X10  | 9-40795  | 4 | XX            |     |

(XX = -810,-814,-819,-824)

(OC = OPEN CUTTER)

(SC = STAGGERED CUTTER)