

USER GUIDE
UGG073-0721

Viper 8 Series Granulator

Models 813, 817



Please record your equipment's model and serial number(s) and the date you received it in the spaces provided.

It's a good idea to record the model and serial number(s) of your equipment and the date you received it in the User Guide. Our service department uses this information, along with the manual number, to provide help for the specific equipment you installed.

Please keep this User Guide and all manuals, engineering prints, and parts lists together for documentation of your equipment.

Date:

Manual Number: UGG073-0721

Serial Number(s):

Model Number(s):

DISCLAIMER: Neither Conair nor its employees shall be liable for errors contained in this User Guide or for incidental, consequential damages in connection with the furnishing, performance or use of this information. Conair makes no warranty of any kind with regard to this information, including, but not limited to, the implied warranties of merchantability and fitness for a particular purpose.

Table of Contents

1-1 Introduction

Purpose of the User Guide	1-2
How the Guide Is Organized	1-2
Your Responsibility as a User	1-2
Foreword	1-3
ATTENTION: Read This So No One Gets Hurt.....	1-4
General Information - Use - Areas.....	1-5
Risks, Protections, and Warnings	1-6
Accident Prevention Guards	1-8
Equipment Symbols	1-9

2-1 Description

What Is the Viper 8 Series Granulator?	2-2
Proper Locations	2-2
Planned Uses, Unplanned Uses, and Improper Use of Granulator	2-2
How the Viper 8 Series Granulator Works	2-3
Specifications	2-5
Base Unit and Motor Drive	2-6
Feeding/Evacuation Configurations	2-7
Rotor Unit and Cutting Chamber	2-8
Evacuation Bin.....	2-9
Control Panel and Wiring Circuit.....	2-10

3-1 Installation

Unpacking the Boxes	3-2
Wiring	3-4
Preparing for Installation	3-5

4-1 Operation

General Information	4-2
Front Panel Controls	4-2
Inspections and Operational Tests of Safety Devices.....	4-3
Irregular Situations, Emergencies, and Alarms	4-3
Stopping the Granulator	4-4

5-1 Maintenance

Maintenance of Your Granulator	5-2
Preventative Maintenance Schedule	5-2
Accessing the Granulator Enclosure	5-3
Cleaning	5-3
Safety Devices.....	5-3
Safety Devices - Inspection	5-4
Replacing Rotor Knives and Fixed Knives	5-5
Sharpening Rotor Knives	5-6
Assembly and Adjustment of Clearance between the Rotor Knife and Fixed Knives.....	5-7
Bearing Greasing	5-9
Drive Belt Inspection	5-11
Taper-lock Bushing.....	5-13
Hopper Tilt/Open Sequence.....	5-15

Bin Removal Sequence	5-17
Checking the Circuit Breaker	5-19
Cutting Chamber Cleaning	5-20
Replacing the Flaps	5-21
6-1 Troubleshooting	
Before Beginning	6-2
A Few Words of Caution.....	6-2
Identifying the Cause of a Problem	6-3
Process Problems.....	6-4
Mechanical Problems	6-5
Electrical Problems	6-6
A Appendix	
We're Here to Help	A-1
How to Contact Customer Service	A-1
Before You Call.....	A-1
Equipment Guarantee.....	A-2
Performance Warranty.....	A-2
Warranty Limitations	A-2
B Appendix	
Glossary	B-1
C Appendix	
Connecting Accessories and Options	C-1
D Appendix	
Parts List.....	D-1

Introduction

Purpose of the User Guide	1-2
How the Guide Is Organized	1-2
Your Responsibilities as a User	1-2
Foreword	1-3
ATTENTION: Read This So No One Gets Hurt.....	1-4
General Information - Use - Areas.....	1-5
Risks, Protections, and Warnings	1-6
Accident Prevention Guards	1-8
Equipment Symbols	1-9
How to Use the Lockout Device	1-10

Purpose of the User Guide

This User Guide describes the Conair Viper 8 Series Granulators and explains step-by-step how to install and operate this equipment.

Before installing this equipment, please take a few moments to read the User Guide and review the diagrams and safety information in the instruction packet. You also should review manuals covering associated equipment in your system. This review will not take long, and it could save you valuable installation and operating time later.

How the Guide Is Organized

Symbols have been used to help organize the User Guide and call your attention to important information regarding safe installation and operation.



Symbols within triangles warn of conditions that could be hazardous to users or could damage equipment. Read and take precautions before proceeding.



Numbers indicate tasks or steps to be performed by the user.



A diamond indicates the equipment's response to an action performed by the user or a situation.



An open box marks items in a checklist.



A circle marks items in a list.



Indicates a tip. A tip is used to provide you with a suggestion that will help you with the maintenance and the operation of this equipment.



Indicates a note. A note is used to provide additional information about the steps you are following throughout the manual.

Your Responsibility as a User

You must be familiar with all safety procedures concerning installation, operation, and maintenance of this equipment. Responsible safety procedures include:

- Thorough view of this User Guide, paying particular attention to hazard warnings, appendices, and related diagrams.
- Thorough review of the equipment itself, with careful attention to voltage sources, intended use, and warning labels.
- Thorough review of instruction manuals for associated equipment.
- Step-by-step adherence to instructions outlined in this User Guide.

Foreword

This equipment is not dangerous to operators if used in accordance with the information given by Conair and if used within the operating conditions as designed.

Furthermore, the safety equipment must be constantly kept operational. All required maintenance operations must be carried out according to specific schedules.

This User Guide must be kept for the whole lifetime of the machine and must be available to operators and service engineers at all times.

The information in this User Guide is the exclusive property of Conair.

This manual is to serve as a guide for installing, operating, and maintaining the equipment. Improper installation can lead to poor performance, personal injury, and/or equipment damage. We recommend the use of qualified installers and service technicians for all installation and maintenance of this equipment.

This manual is for our standard product. The information in this manual is general in nature. Unit-specific drawings and supplemental documents are included with the equipment as needed. Additional copies of documents are available upon request. We strive to maintain an accurate record of all equipment during the course of its useful life.

Due to the ever-changing nature of applicable codes, ordinances, and other local laws pertaining to the use and operation of this equipment, we do not reference them in this manual.

There is no substitute for common sense and good operating practices when placing any mechanical equipment into operation.

We encourage all personnel to familiarize themselves with this manual's contents. Failure to do so may unnecessarily prolong equipment down time.

We trust your equipment will have a long and useful life. If you should have any questions, please contact our Service Department specifying the serial number and model number of the unit as indicated on the nameplate.

Contact Conair
Parts and Service
Phone: 800-458-1960
From outside of the
United States,
Call: 814 437 6861

ATTENTION:

Read This So No One Gets Hurt

We design equipment with the user's safety in mind. You can avoid the potential hazards identified on this machine by following the procedures outlined below and elsewhere in the User Guide.



WARNING: Improper installation, operation, or servicing may result in equipment damage or personal injury.



This equipment should be installed, adjusted, and serviced by qualified technical personnel who are familiar with the construction, operation, and potential hazards of this type of equipment.

All wiring, disconnects, and fuses should be installed by qualified electrical technicians in accordance with electrical codes in your region. Always maintain a safe ground. Do not operate the equipment at power levels other than what is specified on the machine serial tag and data plate.



WARNING: Voltage hazard



This equipment is powered by three-phase alternating current, as specified on the equipment serial tag and data plate.

A properly sized conductive ground wire from the incoming power supply must be connected to the chassis ground terminal inside the electrical enclosure. Improper grounding can result in severe personal injury and erratic machine operation.

Always disconnect and lock out the incoming main power source before opening the electrical enclosure or performing non-standard operating procedures, such as routine maintenance. Only qualified personnel should perform troubleshooting procedures that require access to the electrical enclosure while power is on.



DANGER: Sharp Rotor Knives

Most injuries caused by rotor knives occur when the granulator has been turned off. Handle rotor knives with care at all times.

- Always wear cut-resistant gloves when the granulator chamber is open and when handling rotor knives.
- Always lock out power to the granulator before opening the granulator chamber.

General Information - Use - Areas

The employer shall provide the staff with instructions on injury risks, operator safety equipment, noise emission risks, and on general accident prevention rules according to the international directives and to the legislation of the country in which the machine will be used.

The behavior of personnel, maintenance service engineers, cleaning personnel, inspectors, etc., shall, in any case, conscientiously comply with the accident prevention standards of the country in which the equipment will be used.

This manual only refers to the equipment described herein.

The equipment must only be used by trained operators who have completely read and understand the instructions described in this User Guide.

All instructions, warnings, and general accident prevention rules described in this User Guide must be observed. The manufacturer is not responsible for non-observance of these rules.

 **NOTE:** Before starting work, the operator shall be fully aware of the position and functioning of all controls and features of the equipment. Furthermore, the operator must completely read and understand this User Guide, and take all appropriate safety precautions.



Use Cut Resistant Gloves



Do Not Wear Jewelry

Risks, Protections, and Warnings

General Safety

In order to ensure the health and safety of exposed persons, the granulator has been equipped with the following safeties:

- Fixed guards; and
- Removable guards.

Fixed Safeties

Protective casings, insulating box, and anti-fly-back flaps.

Removable Safeties

These devices and circuits monitor access to the cutting chamber and drive belt.

The cutting chamber is monitored by a safety system designed to protect operators from danger and personal injury.

A mechanical safety monitors the position of the guards by means of limit switches. These limit switches - appropriately connected to the auxiliary circuit - stop the electric motor if the guards are not closed. The control circuit is periodically checked after every startup in order to ensure proper operation. The motor cannot be restarted if power contactor anomalies are found.

Access to the drive area is blocked by a mechanical lock and can be opened by special keys.

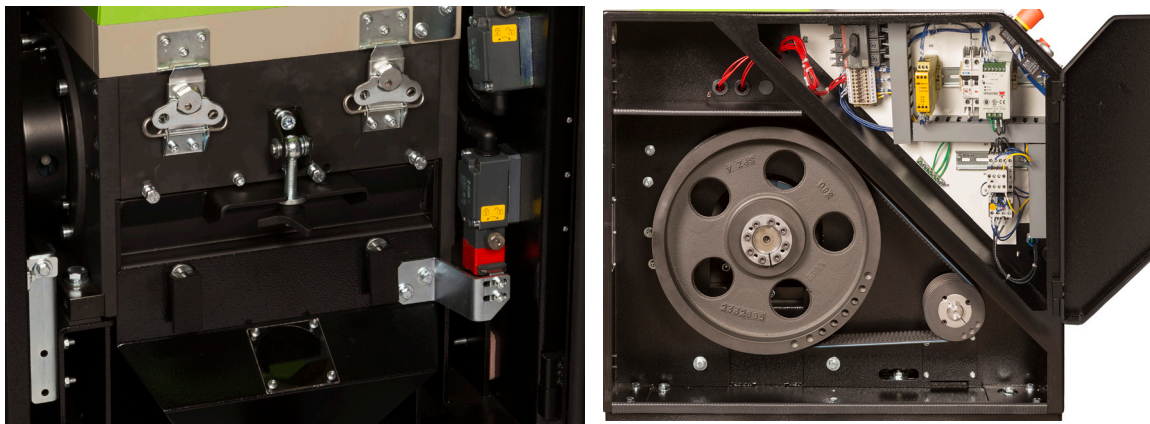

Risks, Protections, and Warnings (continued)

 **NOTE:** If the granulator is supplied with a Roll Feed (traction unit), please refer to the instructions shipped with your equipment.

 **Important!
Granulator Balance**

When the hopper has been tilted / opened, be very careful as the machine could be thrown off balance more easily (*see section on “Maintenance”*).

 **Cutting Edge of Rotor Knives or Hazardous Exposure to Cuts**

Whenever it is necessary to work near the rotor knives of the rotor, use caution. The rotor knives are sharp and may cause injuries.

Although there are safety micro-switches, there are no mechanical interlocks on the rotor. Therefore, when accessing the cutting chamber, remember that the rotor, even if moved manually, could cause serious injuries if parts of the body are inside the chamber.

 **Injuries When Lowering the Hopper - Pinch Hazard**

When the hopper is being lowered, keep hands and arms away from the hopper/granulator meeting surfaces.

Contact Conair
Parts and Service
Phone: 800-458-1960
From outside of the
United States,
Call: 814 437 6861

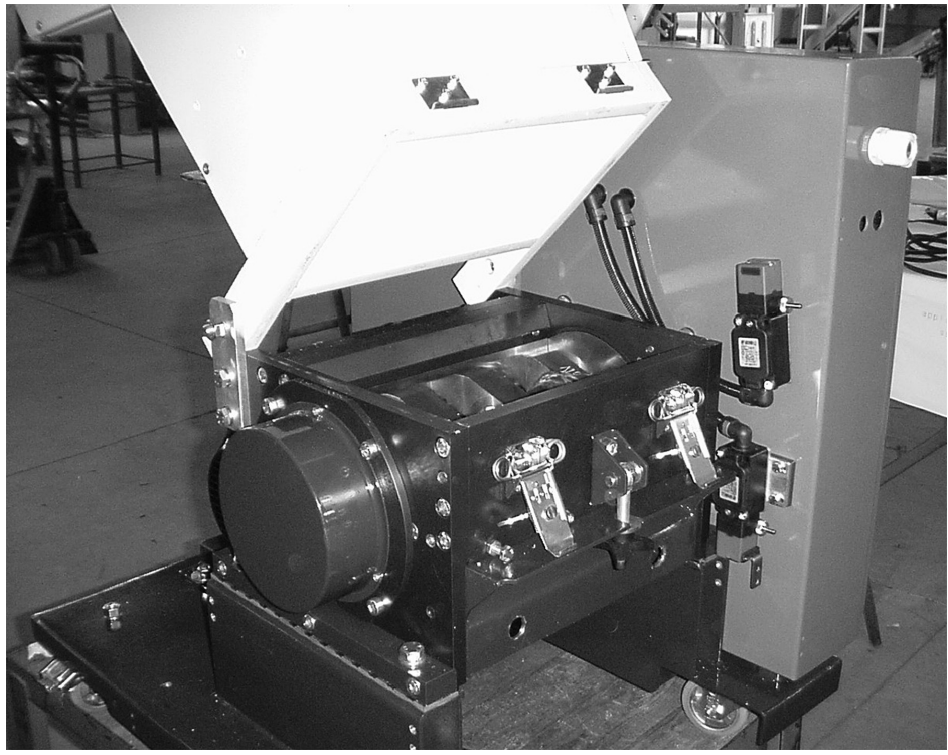

The hopper opening procedure should be executed with two hands to avoid a tipping risk, sharp knife contact, and pinch hazards.

Accident Prevention Guards



Important!

Do not tamper with or remove guards and tags. The manufacturer refuses all responsibility concerning the safety of the equipment if these items have been removed.



Equipment Symbols - Safety

Danger and Attention



High Voltage



Noise Reduction Opening



Danger of Physical Injury



Sharp Rotor Knives



Pinch Hazard



No Maintenance on Moving Parts



No Removal of Safety Devices and Safety Guards



Use Appropriate Protective Devices/ Clothing

Miscellaneous



Hoist Points (See Section on General Information)



Use Safety Glasses



Danger When Opening the Door



Sharp Rotor Knives Cutting



Moving and Rotating Equipment

How to Use the Lockout Device



CAUTION:

Before performing maintenance or repairs on this product, you should disconnect and lockout electrical power sources to prevent injury from unexpected energization or start-up. A lockable device may be provided to isolate this product from potentially hazardous electricity.



WARNING:

Before removing lockout devices and returning switches to the ON position, make sure that all personnel are clear of the machine, tools have been removed and all safety guards reinstalled.

 **NOTE:** Your lockout device may appear slightly different than the one shown in this sample.

Lockout is the preferred method of isolating machines or equipment from energy sources. Your Conair product may be equipped with a lockout device similar to the one pictured below. To use the lockout device:

- 1 Stop or turn off the equipment.**
- 2 Isolate the equipment from the electric power.**
- 3 Turn the rotary disconnect switch to the OFF, or “O” position**
- 4 Secure the device with an assigned lock or tag.**
- 5 The equipment is now locked out.**

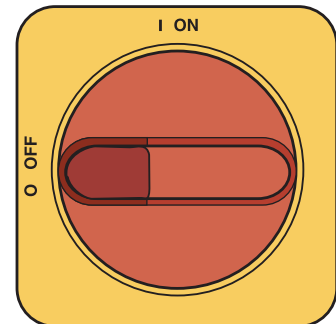
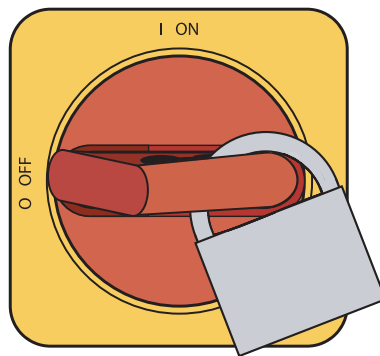
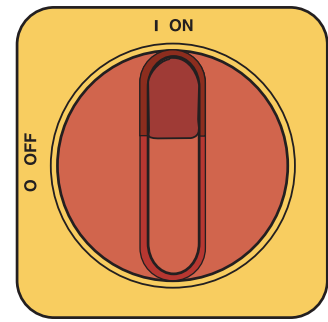

If the equipment has no included lockout device, perform the same procedure upstream of the device as part of premises electrical system.

Description

What Is the 8 Series Granulator? 2-2

Proper Locations 2-2

Planned Uses, Unplanned Uses, and Improper
Use of Granulator 2-2

How the 8 Series Granulator Works 2-3

Specifications 2-5

Base Unit and Motor Drive 2-6

Feeding/Evacuation Configurations 2-7

Rotor Unit and Cutting Chamber 2-8

Evacuation Bin..... 2-9

Control Panel and Wiring Circuit 2-10

What Is the 8 Series Granulator?

A granulator is designed to cut and granulate pieces and scraps of plastic material with minimum use of energy. Basically, the equipment includes a hopper, cutting chamber, and a discharge.

The granulator walls are sound-reducing, designed to decrease noise pollution.

Conair granulators are designed for granulating injection molded, blow molded, or extruded plastic scrap. The function of the granulator can be described as follows:

- The plastic scrap, which must be free from metal and contamination, is fed into the granulator's inlet.
- The plastic scrap falls through the hopper and down into the cutter housing. The cutter housing contains fixed knives and a rotor.
- Rotor knives are mounted on the rotor. The plastic scrap is granulated (cut) between the rotor knives on the rotor and the fixed knives in the cutter housing. Both rotor knives and fixed knives must be replaced or sharpened as necessary.
- The size of the granulate (the cut plastic scrap) is determined by the screen.
- The screen is installed in the screen box in the base of the cutter housing. The screen can easily be changed to give the required granulate size. The screen hole size determines the granulate size.
- The granulate passes through the screen down into the evacuation bin, which collects the finished granulate. The evacuation bin can be emptied manually or evacuated by means of a blower.



IMPORTANT: The granulator must never be used with dull rotor knives. Dull rotor knives cause abnormal wear and damage the granulator.



NOTE: If the granulator is supplied with a Roll Feed (traction unit), please refer to the manual shipped with your Roll Feed (traction unit).

Proper Locations

- 1 The equipment must be levelled correctly and properly fixed to the floor. This equipment is for indoor use only.
- 2 The location should allow normal equipment operating actions and routine maintenance with good lighting and proper ventilation.

Planned Uses, Unplanned Uses, and Improper Use of Granulator

The granulator must be used for granulating the product specified in the contract within the capacity limits identified in the contract. Always check that the material to be ground is not contaminated (e.g. rocks, iron, dirt, etc.).

Using the granulator for granulating other materials or for applications not provided for in the regulations is considered "MISUSE". Therefore, the manufacturer refuses any responsibility concerning damages caused to things or people, and will consider any type of equipment warranty no longer valid.



IMPORTANT: Using the equipment when not explicitly permitted by the instructions specified in the User Guide is considered unplanned or improper, and forbidden, voiding the warranty. Misuse is also dangerous/unsafe for operators and other personnel.

Planned Uses, Unplanned Uses, and Improper Use of Granulator (Continued)

Do not place any part of your body inside the granulator or put improper objects in it.

Do not approach moving parts or parts that could start moving, with any type of object.

Do not disconnect any accessories when the equipment is in operation or in possible startup conditions (power supply connected).

How the 8 Series Granulator Works

The granulating process takes place as described below.

The scrap to be ground is fed into the hopper and follows the path shown by the arrows. It falls into the cutting chamber, along the anti-fly-back channel which is shaped to prevent material from coming out during the granulating phase. Here, it is cut by a rotor with hardened rotor knives. The cutting action is achieved between a rotor knife and a fixed knife.

A drilled screen located under the rotor allows the properly sized material to spill into the bin. The dimension of the holes in the screen determines the size of the granule.

At this point, the recycled granule is picked up by the evacuation system.

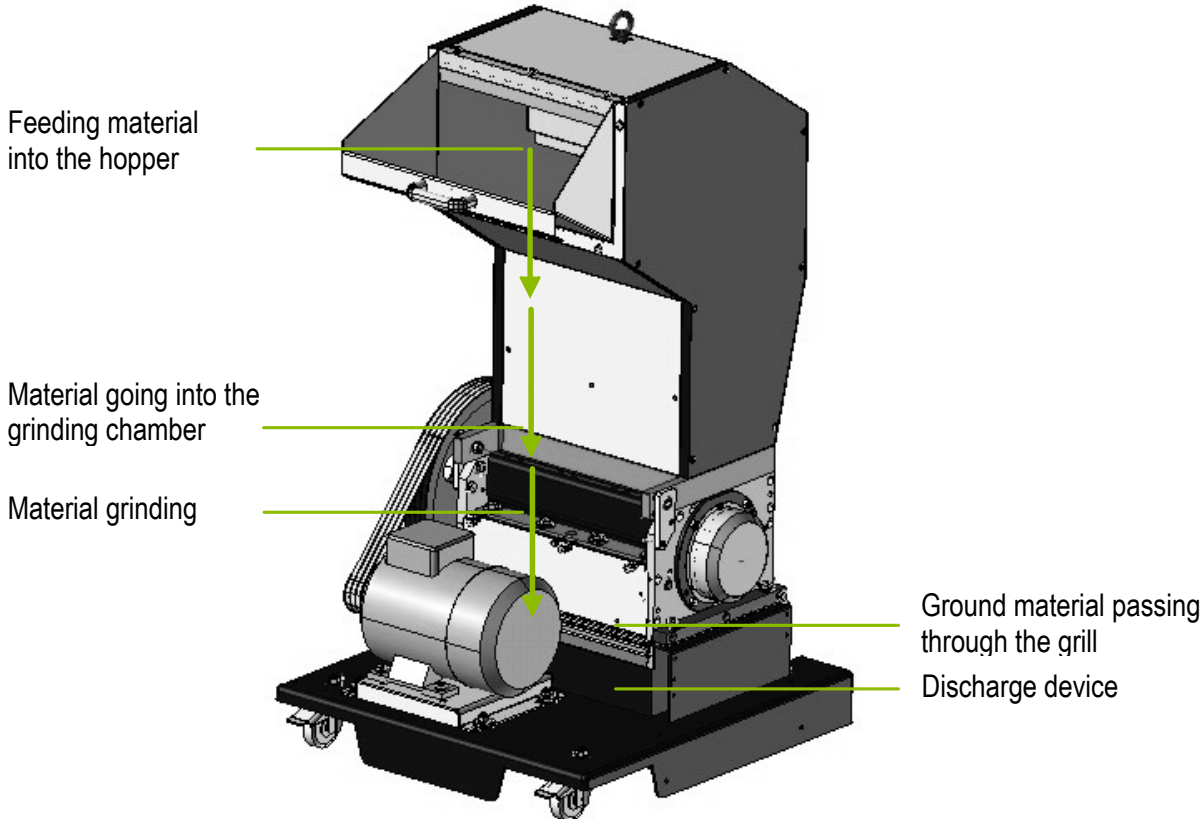

(Continued)

How the 8 Series Granulator Works (Continued)

The main units of the granulator are:

- Feeding unit/hopper (1);
- Rotor unit and cutting chamber (2-3);
- Bin and evacuation (4); and
- Base unit and motor drive (5).

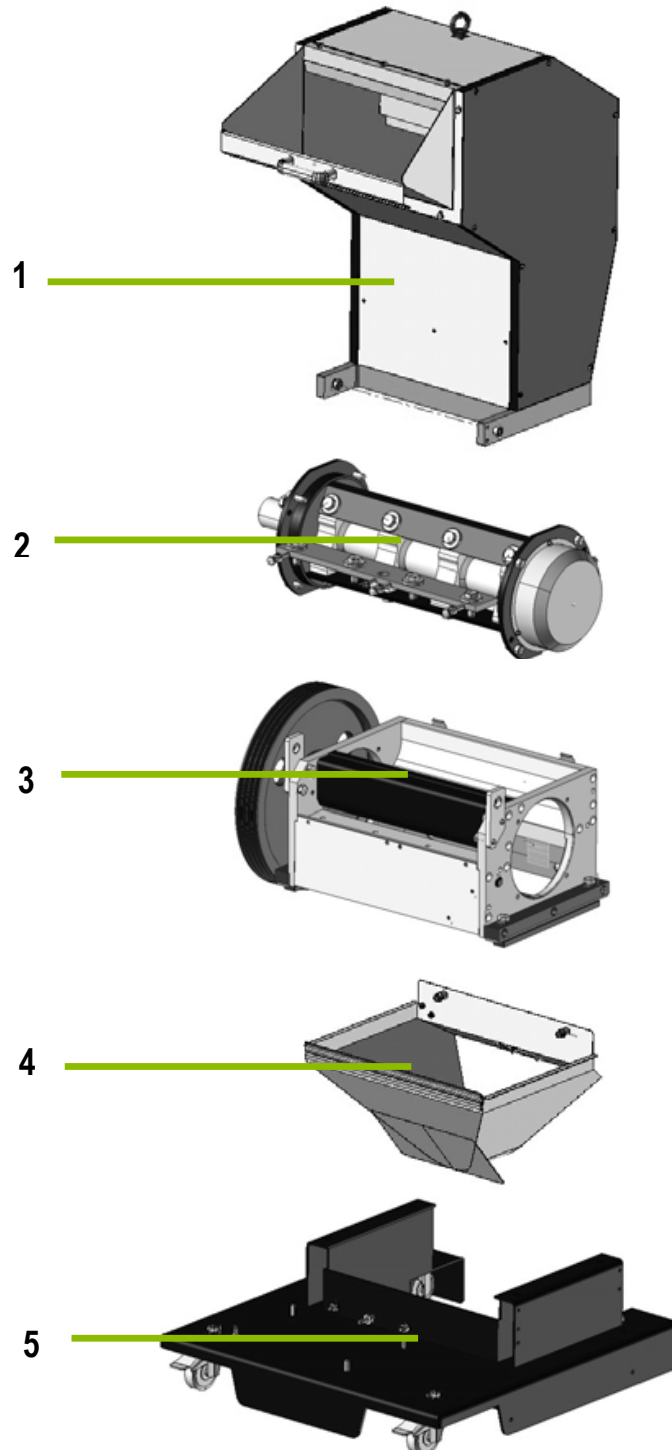

Specifications

The technical specifications of the equipment are shown below (data only referred to the granulator).

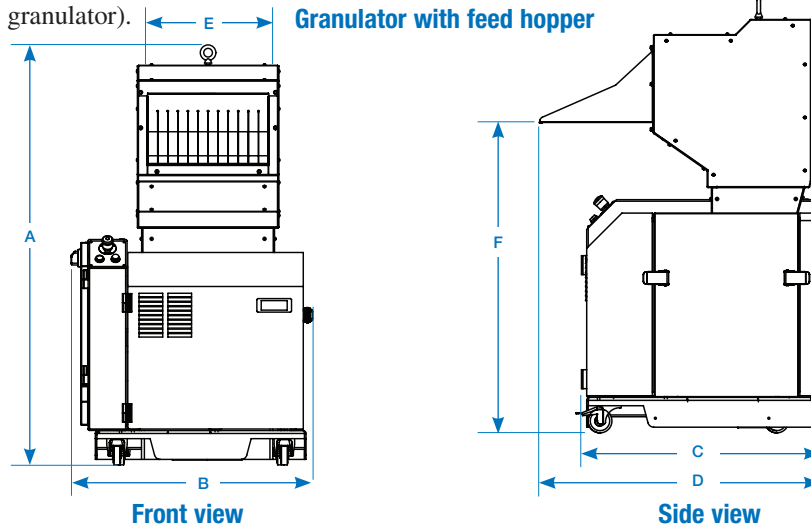

Application Note

Allow appropriate clearance above machine for hopper tilting during maintenance.

Models	813	817
Performance characteristics		
Throughput range * lbs/hr {kg/hr}	up to 190 {86}	up to 275 {125}
Rotor diameter inches {mm}		7 {180}
Rotor speed rpm		280
Rotor type		3-blade weldedopen
Rotating knives x fixed knives		3 x 2
Standard screen hole size inches {mm}		3/16 {5}
Cutter house configuration		tangential
Cutting chamber inches {mm}	7.8 x 12.6 {200 x 320}	7.8 x 16.5 {200 x 420}
Motor power Hp {kW}	5 {4} standard ; 7.5 {5.5} optional	5 {4} standard ; 7.5 {5.5}, 10 {7.5} optional
Dimensions inches {mm}		
A - Overall height		54.8 {1391}
B - Width	26.8 {680}	30.7 {780}
C - Depth		29.9 {760}
D - Overall depth		36.8 {935}
E - Feed hopper opening width	12.2 {310}	16.1 {410}
F - Height to hopper infeed		41.0 {1041}
Approximate weight † lb {kg}		
Installed	705 {320}	836 {380}
Shipping	900 {408}	1075 {488}
Voltages Full load amps based on motor size ‡		
		5 Hp
230/3 phase/60 Hz		13.0
460/3 phase/60 Hz (standard)		6.5
575/3 phase/60 Hz		5.2

Specification Notes

* Throughputs are provided as a capacity guideline only. Throughput will be greater or lesser than the values shown according to the selected screen size and the shape, size, thickness and properties of the material to be cut.

† Weight is estimated and will vary based on configuration

‡ FLA data for reference purposes only. Does not include any accessories added such as blower or conveyor motor loads. Includes main 5 Hp motor only. For true, full FLA for power circuit design of specific machine refer to electrical

diagram of the machine order or nameplate applied to machine at shipment. Other voltages available.

Consult Conair for a material test to help in determining the correct granulator model for your application.

Specifications may change without notice. Consult with a Conair representative for the most current information.

Base Unit and Motor Drive

The base (6) is made of metal; it is mounted on the casters (5). The motor drive consists of a three-phase asynchronous motor with four mounting bolts (4), sliding on the base so that it serves as a tightener (2 - motor pulley) for the V-belt drive (3). The V-belt drive transfers power to the rotor flywheel (1), carrying out a vibration damping action at the same time.

A fixed protection covers the driving pulley, belts, and flywheel pulley to ensure operator's safety.

The driving pulley (2) and the flywheel pulley (1) are respectively mounted with a tapered bushing and a self-locking element to optimize the driving transmission and the alignment of the belts.

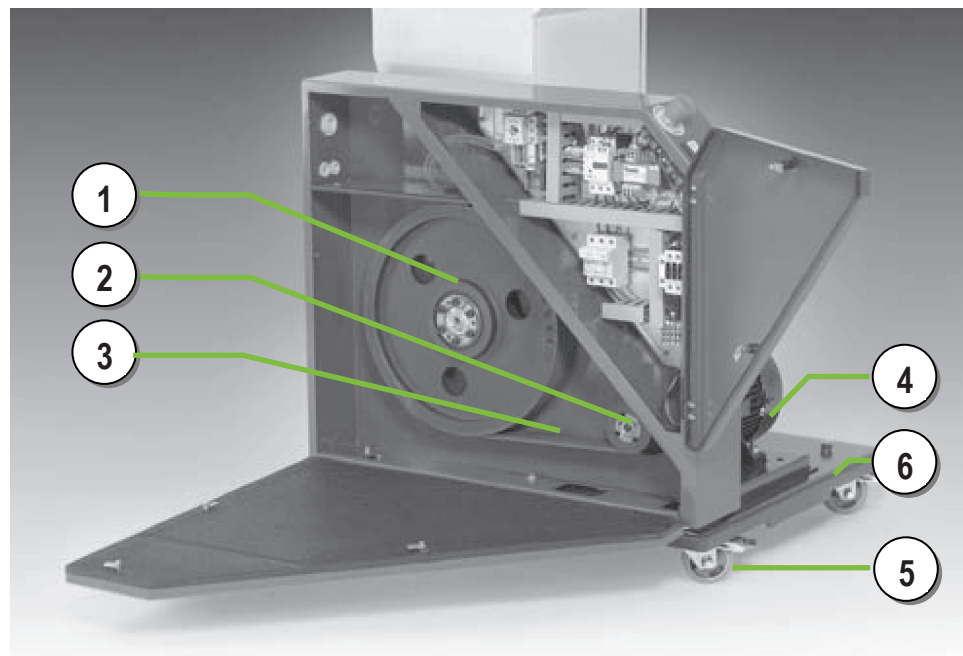

Feeding/Evacuation Configurations

Hand Feeding

The standard top feed hopper allows easy dropping of scrap into the granulator by hand. Safe, low speed/ low noise operation means the 6-Series can be located near personnel with no concerns.

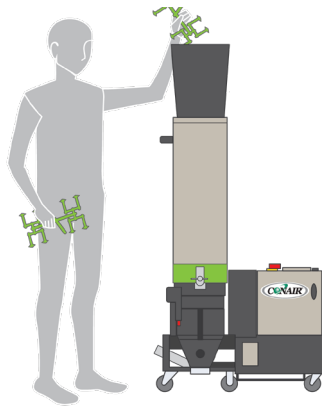

Robot Feeding

The standard, open top feed hopper includes a bolt-on funnel that provides a large target for robotic scrap feeding.

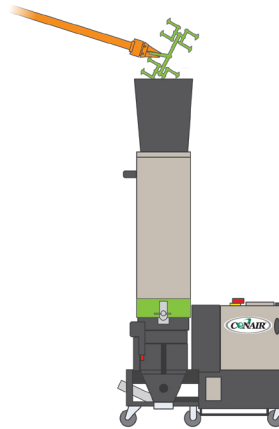

Description
2

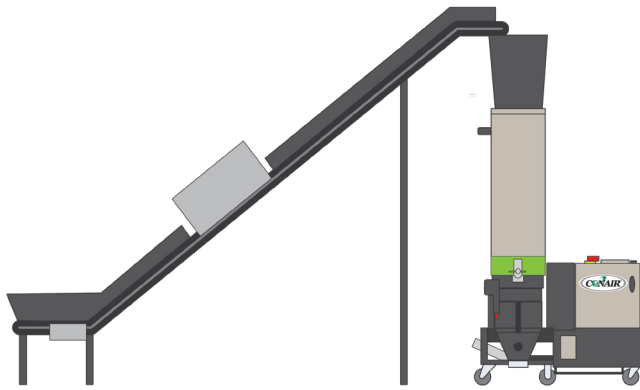

Conveyor Feeding

Optimized, meter feeding of scrap by a compact, speed-controlled conveyor. Conveyor can include a metal detector that stops conveying when metal in the scrap is detected.

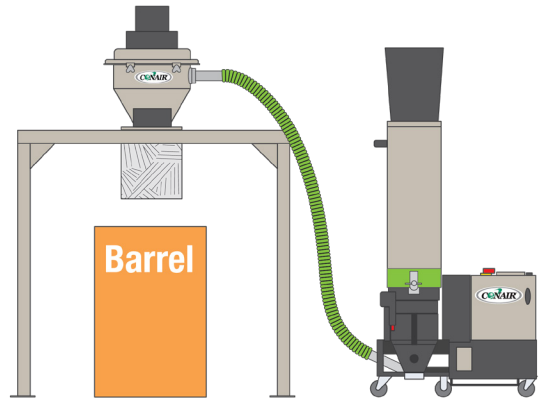

Vacuum Take-off Evacuation

A vacuum pick-up tube is used to pull granulate from the compact drawer. Multiple types of loaders/receivers can be used, programmed to convey by a sensor in the granulator drawer or special loading control settings.

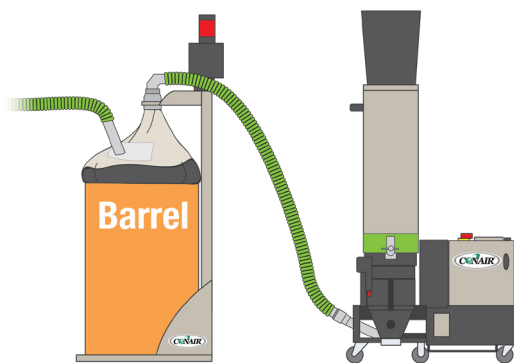

Compressed Air to EVB Evacuation

A pick-up tube with venturi is used to pull granulate from the granulator drawer and push it into a barrel. Conair's CAML-EVB compressed air evacuation system can be set to move granulate on a timed basis, or with a demand sensor.

Vacuum System Evacuation

Multiple granulators can be emptied by a central vacuum system to a common collection bin or box. Each granulator is equipped with a vacuum pick-up tube and a material line valve, sequenced by the central loading control (e.g. Conair FLX-128).

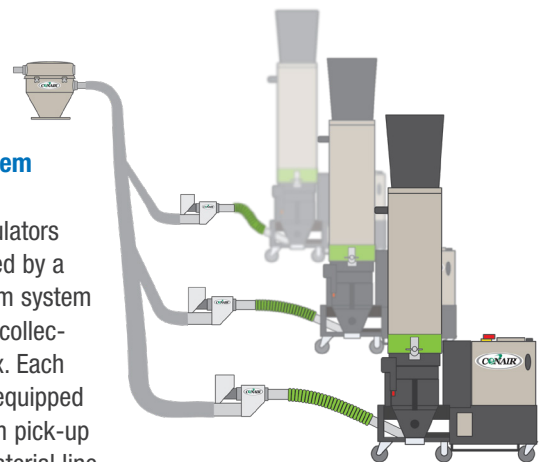

Rotor Unit and Cutting Chamber

The cutting chamber is where the rotor cuts the material introduced by the feeding hopper. The rotor holds the rotating knives.

Cutting takes place in several stages in the cutting chamber. First, the part is cut into small bites between the rotating knives, and the fixed knives. Then the bites are cut into smaller granules as the rotating knives cut them against the screen, and the pieces fall through the screen into the bin. The final size of the granule is determined by the screen size.



Evacuation Bin

The evacuation bin consists of a:

- Sizing screen and
- Evacuation bin or collecting bin (optional).

The granulating phase goes on until the material introduced reaches the required dimension (granule size). This is achieved by means of a drilled screen located in the cutting chamber discharge area. The only way for the granulated material to exit is through the uniformly spaced holes in the screen. Therefore, the granule size is dependent on the diameter of the holes.

The granulated material drops into the evacuation bin (1) or collecting bin (2) which lets you manually remove the product.

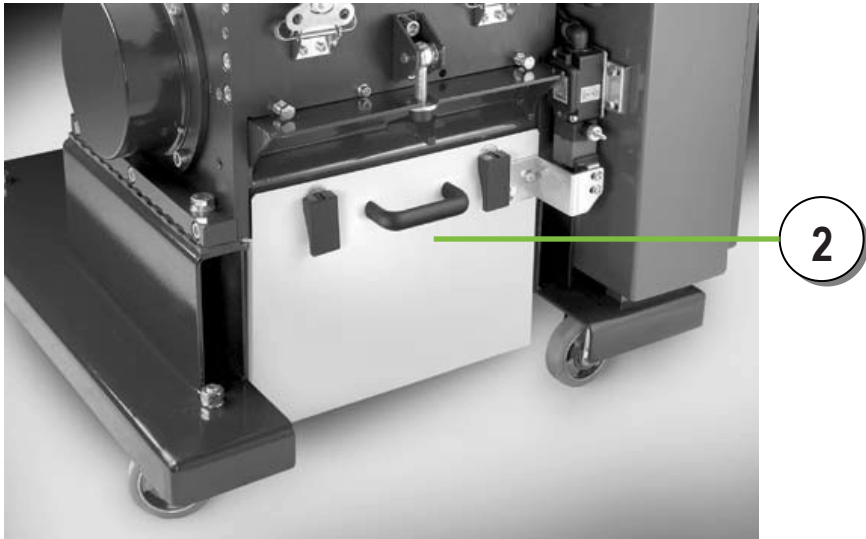
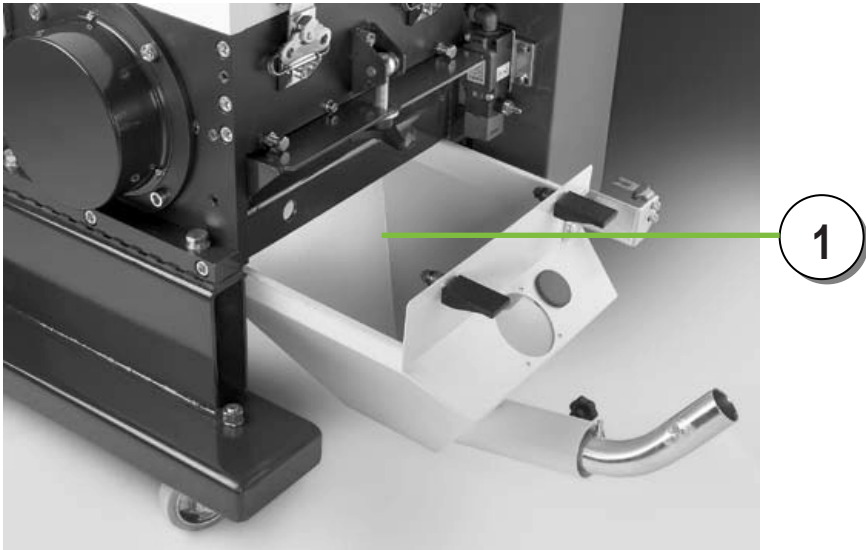

Control Panel and Wiring Circuit

The electric cabinet is normally integrated in the casing unit and contains all electromechanical components and controls required for managing electrical power.



WARNING: Improper installation, operation, or servicing may result in equipment damage or personal injury/death.



This equipment should be installed, adjusted, and serviced by qualified technical personnel who are familiar with the construction, operation, and potential hazards of this type of equipment.

All wiring, disconnects, and fuses should be installed by qualified electrical technicians in accordance with electrical codes in your region. Always maintain a safe ground. Do not operate the equipment at power levels other than what is specified on the machine serial tag and data plate.





Pos.	Description
1	Main Switch/Lockout Device
2	Emergency Stop
3	Start Button
4	Stop Button

Installation

Unpacking the Boxes	3-2
Wiring	3-4
Preparing for Installation	3-5

Unpacking the Boxes

 **NOTE:** When unloading, at least two qualified technicians should be present (lift truck operators, crane operators).

 **WARNING:** Personnel must not walk under or pass by goods being loaded/unloaded. The same goes for the signaler who shall provide assistance for handling.

Conair refuses all responsibility concerning this step which must be carried out by qualified industrial machinery handling personnel (lift truck operators, slingers), provided with the required protective equipment (safety shoes, work gloves, helmet, goggles).

 **IMPORTANT!:** At least a 5000 lb capacity forklift or crane, with appropriately sized straps, must be used as shown to lift and move the granulator. The lifting lug on the hopper should NOT be used to lift the granulator.

 **IMPORTANT!:** Lift the granulator as shown in the illustration. Do not use a lifting lug on the hopper. This lug is designed only to install the hopper on the chassis, and is not designed to lift the entire machine.

 **WARNING:** Keep body and hands away when the equipment is being lowered. Non-compliance with these instructions could result in serious injuries.

Upon receiving the shipment, always perform a thorough inspection of the contents and compare it to the enclosed packing list. Make sure all parts listed are present and that no visible damage exists.

Inspect all of the equipment in the presence of the freight carrier's representative for damage during shipment. Note any damage on the delivery receipt before signing it. If damage is evident, file a claim immediately against the carrier as it is their responsibility to pay for any damage incurred during shipping. Make sure to include a detailed report of the damage along with photos.

Conair granulators come in one or more boxes/skids depending on the model and options ordered. Depending on which model is ordered, the granulator may come fully assembled as a single unit, or as a base and hopper separated, in addition to any other options ordered as part of your granulating system.

- 1 Carefully remove the granulator and components from their shipping container(s).** Note that the granulator is secured to its shipping container.
- 2 Unbolt any additional items secured to the shipping pallet.**
- 3 Remove all packing material, protective paper, tape and plastic.**
- 4 Identify all components** supplied with the selected configuration, and carefully inspect all components to make sure no damage occurred during shipping and that you have all the necessary hardware.
- 5 Take a moment to record serial numbers** and electrical power specifications in the blanks provided on the back of this User Guide's title page. The information will be helpful if you ever need service or parts.

The granulator is easy to install, if you plan the location and prepare the area properly.

 **WARNING: Improper installation, operation, or servicing may result in equipment damage or personal injury.**



This equipment should be installed, adjusted, and serviced by qualified technical personnel who are familiar with the construction, operation, and potential hazards of this type of machine.

All wiring, disconnects, and fuses should be installed by qualified electrical technicians in accordance with electrical codes in your region. Always maintain a safe ground. Do not operate the equipment at power levels other than what is specified on the machine serial tag and data plate.

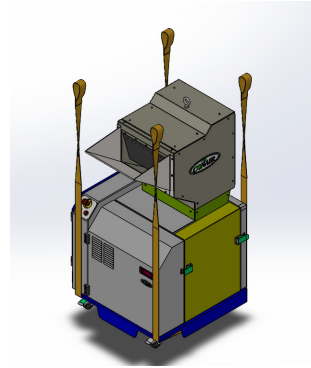

Unpacking the Boxes (Continued)

Make sure the installation area provides:

- A three-phase power source supplying the correct current for your granulator.** Check the serial tag on the unit for required voltage, phase, frequency, and full load amps. Check the last page of the electrical power prints for the disconnect fuse size and minimum wire connection size. All wiring should be completed by qualified personnel and should comply with your region's electrical codes.
- A clean, well-ventilated environment.** The room temperature should not exceed 104°F {40°C} with 95% non-condensing humidity and should not fall below 32°F {0°C}.
- Minimum clearance for safe operation and maintenance.** The diagram at the left shows minimum clearance for operation. You also need enough clearance in rear for water hookups. For maintenance, you should move the granulator to provide at least 36 in. {91 cm} on any side of the granulator. Additionally, your required electrical codes may require a larger service area in front of the electrical panel.

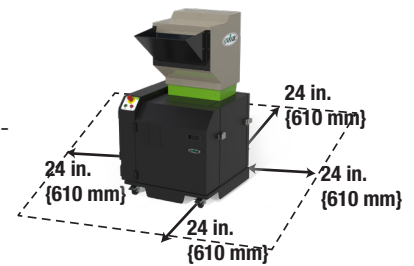

 **NOTE:** The Viper 8 Series requires front and rear access. The operator side (front) is where feeding and control occurs. The rear side is access to the bin and screen.

Wiring



WARNING: Improper installation, operation, or servicing may result in equipment damage or personal injury.



This equipment should be installed, adjusted, and serviced by qualified technical personnel who are familiar with the construction, operation, and potential hazards of this type of equipment.

All wiring, disconnects, and fuses should be installed by qualified electrical technicians in accordance with electrical codes in your region. Always maintain a safe ground. Do not operate the equipment at power levels other than what is specified on the machine serial tag and data plate.

This operation must be carried out by a qualified technician (electrician), and in accordance to local, regional, and national guidelines.

Before connecting the equipment to the main power, it is necessary to:

- Check if the voltage shown on the equipment matches the power supply voltage (permissible variation: voltage $\pm 10\%$, mains frequency: $\pm 2\%$).
- Make sure the ground system is properly connected to the outlet.
- Make sure the electric panel power supply line is able to supply power at least equal to the power on the machine (including the motor breakaway current).
- The equipment has a connection cable (3-poles + ground) with a suitable cross section. It must be connected - in accordance with the user's country current regulations - to a suitable plug (not supplied), according to the customer's needs.
- Make sure the equipment is not crushing the power cable.
- Protect the power supply line from over-voltage (e.g. atmospheric discharges).
- Protect the power supply line from thermal or magnetic over-voltage with appropriately coordinated devices (fuses or automatic switches).

 **NOTE:** For granulators with a Roll Feed (traction unit), see instructions shipped with your Roll Feed (traction unit).

Contact Conair
Parts and Service
Phone: 800-458-1960.
From outside of the
United States,
Call: 814 437 6861.

 **NOTE:** This information is for standard 460 units. Refer to the wiring diagrams that came with your equipment.

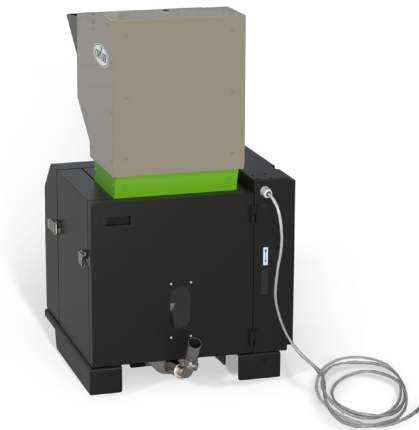

Preparing for Installation

Granulator Cleaning

In order to protect the cutting chamber, Conair covers the equipment with a layer of lubricant. It is recommended that this layer be removed using a non-corrosive detergent before starting up.



DANGER: Sharp Rotor Knives

Most injuries caused by rotor knives occur when the granulator has been turned off. Handle rotor knives with care at all times.

- Always wear cut-resistant gloves when the granulator chamber is open and when handling rotor knives.
- Always lock out power to the granulator before opening the granulator chamber.

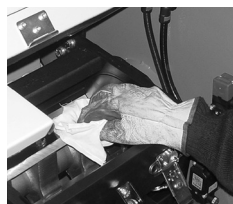

Direction of Rotation of Motor

Reverse phases if the motor runs opposite the direction shown by the arrow located on the belt guard casing.



WARNING: Voltage hazard



This equipment is powered by three-phase alternating current, as specified on the equipment serial tag and data plate.

A properly sized conductive ground wire from the incoming power supply must be connected to the chassis ground terminal inside the electrical enclosure. Improper grounding can result in severe personal injury and erratic machine operation.

Always disconnect and lock out the incoming main power source before opening the electrical enclosure or performing non-standard operating procedures, such as routine maintenance. Only qualified personnel should perform troubleshooting procedures that require access to the electrical enclosure while power is on.



(Continued)

Preparing for Installation (Continued)

Screen

Before operating the equipment, it is necessary to check to make sure the screen is properly fixed to the support and if it is suitable for the granule size required for production (*see the Maintenance section*).



Rotor Knives and Fixed Knives

Before operating the equipment, it is necessary to check to make sure the rotor knives are intact, properly fixed to the support, and properly adjusted (*see the Maintenance section*). This inspection may be left out if the installation is carried out by Conair technicians.



DANGER: Sharp Rotor Knives

Most injuries caused by rotor knives occur when the granulator has been turned off. Handle rotor knives with care at all times.

- Always wear cut-resistant gloves when the granulator chamber is open and when handling rotor knives.
- Always lock out power to the granulator before opening the granulator chamber.



Operation

General Information	4-2
Front Panel Controls	4-2
Operation of the Granulator	4-3
Inspections and Optional Tests of Safety Devices	4-3
Irregular Situations, Emergencies, and Alarms	4-3
Stopping the Granulator	4-4

General Information

 **NOTE:** For granulators with a Roll Feed (traction unit), see instructions shipped with your Roll Feed (traction unit).

Contact Conair
Parts and Service
Phone: 800-458-1960.
From outside of the
United States,
Call: 814 437 6861.

If all installation procedures mentioned so far have been carried out, the granulator is ready for operation. It is now possible to start up the granulator.



WARNING:

Every granulator startup should take place with granulator totally empty.

Front Panel Controls

Refer to electrical drawings that shipped with your equipment.

The main front panel components are:

- **Door-lock main switch (lockout device)**

This acts directly on the main switch: position “0” cuts off power supply to the electric control panel in order to open the electric control panel door; position “1” connects the circuit to the power supply mains.

- **Start button and stop button**

Each motor in the system is controlled by start buttons and stop buttons.

The following conditions are required for operation:

- Main switch (lockout device) closed (panel on);
- Emergency stop-button inactive (released);
- Guards closed, and
- No damage to the electromechanical components inside the electric control panel.

The motor starts and the power indicator light illuminates when the start button is pressed. When the stop button is pressed, the motor stops. Power to the control panel remains.

- **Emergency stop button (red mushroom push-button with a yellow background)**

If this button - which should be used only in case of danger - is pressed during normal operation, it will open the control circuit, thereby cutting off power to the motors.

To start up the machine again, after eliminating the emergency condition, reset the E-stop button (2) and turn it counterclockwise. Then press start button (3).

There could be other buttons on the panel: for more information, *refer to the wiring diagram.*

 **NOTE:** If the emergency button has been pressed during the cutting phase, with material inside the cutting chamber, clean the chamber before resetting the emergency button. This is done in order to avoid rotor blockage and belt slippage.

Operation of the Granulator

Check the machine when running **idle**, in other words without material inside.

Before starting the machine with material, it is absolutely necessary to check to make sure that the machine operates properly with no material.

- 1 Power the machine by turning the main switch (1).
- 2 Press the start button on the granulator.



Pos.	Description
1	Main Switch/Lockout Device
2	Emergency Stop
3	Start Button
4	Stop Button

Inspections and Operational Tests of Safety Devices

Inspections and operational tests of the safety devices installed on the granulator **must** be carried out before starting up the granulator and at least every week after starting up the machine.

- Visual inspection for possible damage and correct positioning of the guards.
- The test is carried out by starting the granulator with a manual sequence.

Irregular Situations, Emergencies, and Alarms

 **IMPORTANT:** If any irregular functioning situations described in the troubleshooting table occur, the operator is only allowed to stop the machine. Only qualified personnel are allowed to eliminate the causes that have produced such irregular operation.

Stopping the Granulator

 **NOTE:** In order to avoid problems with the next startup, the granulator must be stopped when the cutting chamber is empty.

Temporary Stop

- 1 Press E-stop button.

Stopping the Machine for an Extended Period

For example at the end of the working day:

- 1 Press motor stop button.
- 2 Disconnect the power supply mains.



WARNING: Improper installation, operation, or servicing may result in equipment damage or personal injury.



This equipment should be installed, adjusted, and serviced by qualified technical personnel who are familiar with the construction, operation, and potential hazards of this type of equipment.

All wiring, disconnects, and fuses should be installed by qualified electrical technicians in accordance with electrical codes in your region. Always maintain a safe ground. Do not operate the equipment at power levels other than what is specified on the machine serial tag and data plate.

Micro Switch Opening and Closing Sequence

Opening

- 1 Press the Stop button on the electric control panel.
- 2 Turn the dial clockwise to unlock the safety switch.

Stopping the Granulator (Continued)

Closing

- 1 Use the main switch then **close the removable guards**.
- 2 Close the micro-switch (1).
- 3 Press the granulator **Start button** on the electric control panel.

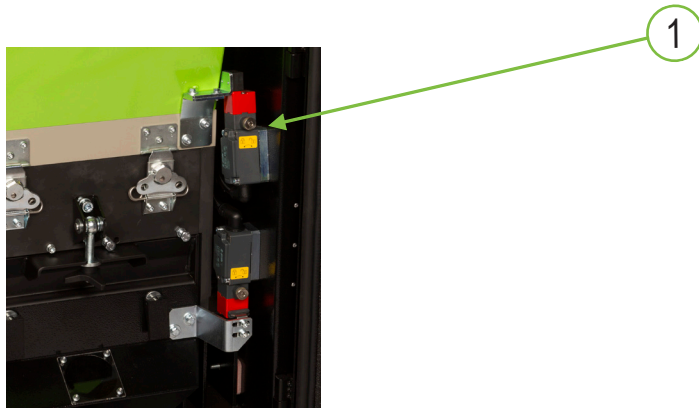

Resetting

Before restarting the granulator, it is necessary to:

- 1 Check the **hopper and evacuation bin lockup** so that the safety limit switches can allow the start up operation (guards in correct position).
- 2 Press the **start button (2)** on the front panel to start the granulator.



Maintenance

Maintenance of Your Granulator	5-2
Preventative Maintenance Schedule	5-2
Accessing the Granulator Enclosure	5-3
Cleaning	5-3
Safety Devices	5-3
Safety Devices - Inspection	5-4
Replacing Rotor Knives and Fixed Knives	5-5
Sharpening Rotor Knives	5-6
Assembly and Adjustment of Clearance between the Rotor Knife and Fixed Knives	5-7
Bearing Greasing	5-9
Drive Belt Inspection	5-11
Taper-lock Bushing	5-13
Hopper Tilt/Open Sequence	5-15
Bin Removal Sequence	5-17
Checking the Circuit Breaker	5-19
Cutting Chamber Cleaning	5-20
Replacing the Flaps	5-21

Maintenance of Your Granulator

Depending on which features, options, and additions you ordered with your granulator, your maintenance procedures may differ from what is shown in this user guide. Please note that all illustrations, photos, and instructions are based on a typical configuration of a granulator. Always refer to the wiring diagrams and other documentation - including manuals from the manufacturer, and parts used on your granulator - when completing any maintenance or troubleshooting tasks.

Contact Conair
Parts and Service
Phone: 800-458-1960.
From outside of the
United States,
Call: 814-437-6861.

If you have any questions or concerns about your granulator, feel free to call Conair's Parts and Service departments for assistance.

Preventative Maintenance Schedule

Once the granulator is in service, we suggest following the maintenance procedures as described. The importance of a properly established preventive maintenance program cannot be overemphasized. Taking the time to follow these simple procedures will result in substantially reduced downtime, reduced repair costs, and an extended useful lifetime for the unit. However, to maintain the best performance, we recommend the following maintenance schedule.

- **Daily or as often as necessary.**
 - Disassemble rotor knives and fixed knives.**
 - Sharpen rotor knives and fixed knives.**
 - Assemble and adjust the clearance between rotor knives and fixed knives.**
 - Perform maintenance on the hopper.**
 - Remove bin and screen.**
 - Perform opening door sequence.**
 - Replace screen.**
 - Clean cutting chamber.**
 - Clean cutting chamber mating surfaces.**
 - Replace straps.**
 - Keep the unit and the area around it clean.**

Check for and remove lint, dust, or other obstructions on the granulator, especially around air vent areas. Keep floor around the unit dry.
- **Monthly or as often as necessary.**
 - Inspect safety devices.**
 - Inspect/replace hopper flaps.**
- **Quarterly (every three months) or as often as necessary.**
 - Grease bearings.** *Refer to "Bearing Greasing" in this section.*
- **Every six months or as often as necessary.**
 - Check / Replace drive belt.**

Contact Conair
Parts and Service
Phone: 800-458-1960
From outside of the
United States,
Call: 814-437-6861

Accessing the Granulator Enclosure

Depending on which model, features, options, and additions you ordered with your equipment, it may appear different and operate differently from the illustrations and photos shown in this user guide.



WARNING: Electrical shock and hot surface hazards.

Before attempting maintenance of any kind on the granulator, you must stop the unit, disconnect and lockout the main power supply, and allow the unit to cool to less than 100°F {38°C}.

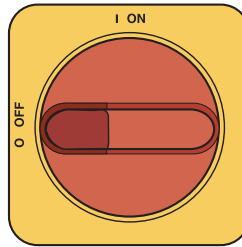

WARNING: Improper installation, operation, or servicing may result in equipment damage or personal injury.



This equipment should be installed, adjusted, and serviced by qualified technical personnel who are familiar with the construction, operation, and potential hazards of this type of machine.

All wiring, disconnects, and circuit breakers should be installed by qualified electrical technicians in accordance with electrical codes in your region. Always maintain a safe ground. Do not operate the equipment at power levels other than what is specified on the machine serial tag and data plate.

Cleaning

Clean the granulator only when it is stopped and electric and pneumatics are locked and tagged out.

Safety Devices

After the beginning of each shift, check the operation of the emergency push-buttons. After starting the motor, press the emergency button: the motor must stop. The control must also include photocells, limit switches on the gates and doors of protection, and other safety devices may be installed.

If any sensors do not work, contact Conair technical support.

IMPORTANT: Do not modify any of the safety devices.

Contact Conair
Parts and Service
Phone: 800-458-1960
From outside of the
United States,
Call: 814-437-6861

Safety Devices - Inspection

 **NOTE:** The following picture shows an example. Please refer to the drawings shipped with your equipment.

These activities – which must be carried out according to the preventative maintenance schedule – will make it possible to identify failures before starting work activities. Electrical devices that need to be checked are: limit switches on removable guards, the emergency stop button, other options ordered.

Make sure the limit switch (1) and support (2) are fastened as the operating machine vibrations could loosen the screws.

 **NOTE:** If the granulator is supplied with a Roll Feed (traction unit), please refer to the manual shipped with your Roll Feed (traction unit).

Contact Conair
Parts and Service
Phone: 800-458-1960.
From outside of the
United States,
Call: 814 437 6861.

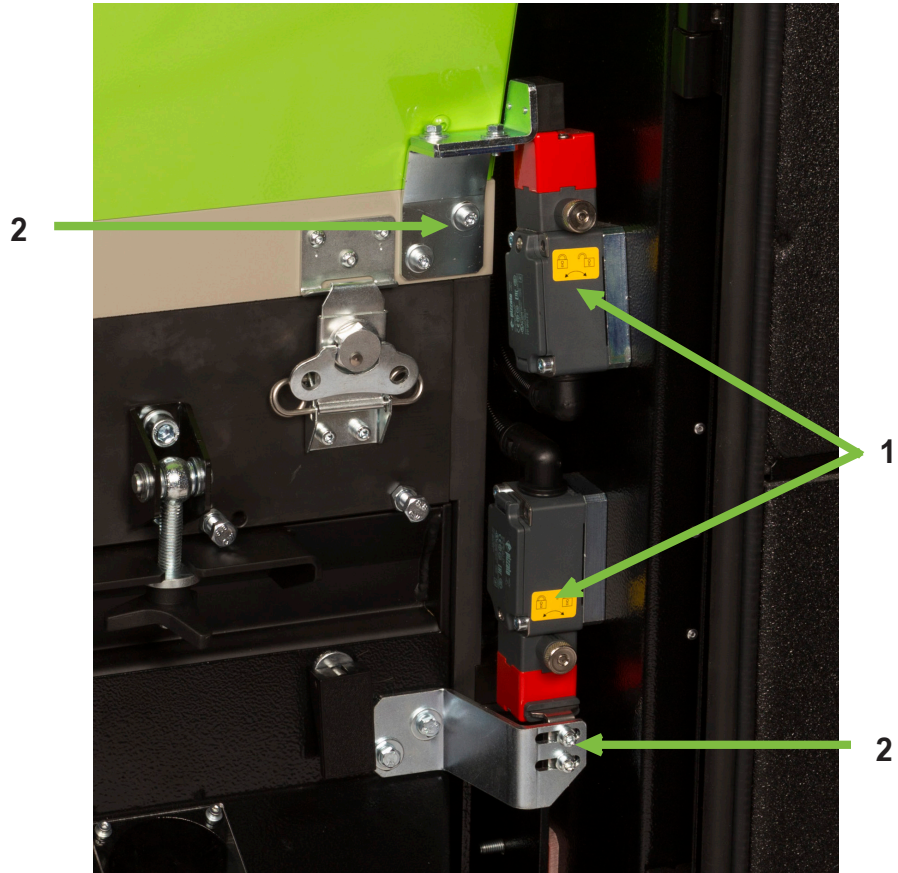

Replacing Rotor Knives and Fixed Knives

When the granulator starts getting particularly noisy or when the ground material starts getting dusty, rotor knives are no longer in good condition and it is time to sharpen or replace them.

Follow the steps below.

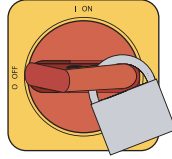

- 1 Disconnect and lockout the main power.**
- 2 Check the orientation of the fixed knives** so that they can meet the movable rotor knives properly. If any metal parts accidentally go inside the granulator, chipping/damaging the cutting edge, the rotor knives will have to be replaced.
- 3 Open the granulator only when you are sure the rotor has stopped.**
By removing a rotor knife, the shaft is thrown off balance and might start turning by itself, thereby bringing its center of gravity downwards. Before removing the rotor knives, block the rotor with a soft wood bar/block.
- 4 Loosen the bolts (2) until they can be extracted, allowing the removal of the rotor knife (1).** Repeat the same operation for the other rotor knives.
- 5 Back up the set screw (6), remove the bolts (4), remove plate of the first fixed knife (5) and, while holding it firmly (gloved hands), pull out the lock screw (7), thereby freeing the fixed knife (3).**

Contact Conair
Parts and Service
Phone: 800-458-1960.
From outside of the
United States,
Call: 814 437 6861.

IMPORTANT: Wear proper cut-resistant gloves: **do not test the cutting edge of the rotor knives, not even with gloves on.**

 **NOTE:** Remember that the rotor knives are hard and fragile. Do not bump or drop them.

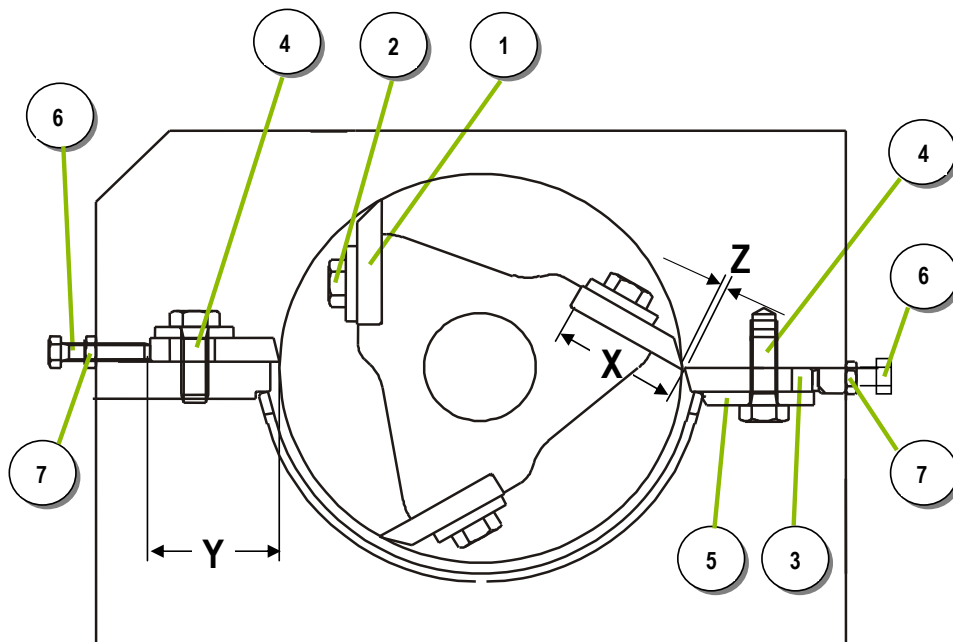

Sharpening Rotor Knives

IMPORTANT: Wear proper cut-resistant gloves. Do not test the cutting edge of the rotor knives, not even when wearing gloves.

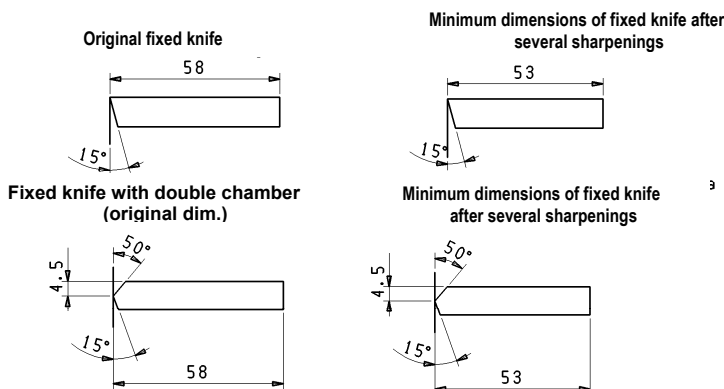
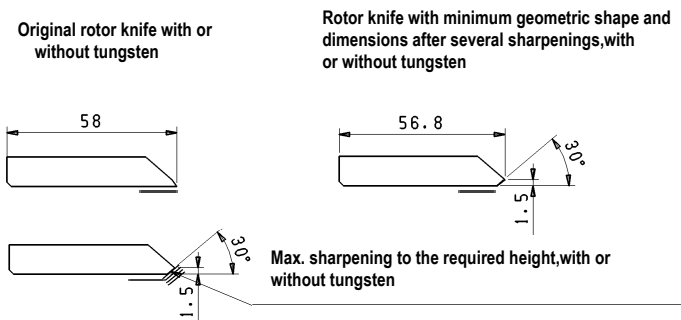

NOTE: Conair recommends having a spare set of rotor knives on hand to minimize down time.

NOTE: Conair offers knife sharpening through Parts - call us first! If you want to sharpen knives yourself, follow these procedures.

Contact Conair
Parts and Service
Phone: 800-458-1960.
From outside of the
United States,
Call: 814 437 6861.

NOTE: Remember that the rotor knives are hard and fragile. Do not bump or drop them.

IMPORTANT: After sharpening, all rotor knives must have the same height.

The rotor knives and fixed knives must be replaced when the height, after several sharpenings, reaches a minimum of 2.24 in. {56.9 mm} (rotor knives) and of 2.09 in. {53.1 mm} (fixed knives) or when they are cracked/chipped. In this last case, thoroughly clean the machine as any metal splinter could cause serious damage.

After the sharpening, the rotor knives and fixed knives have to be pre-adjusted on a work bench by means of the suitable jig supplied by the manufacturers.

When the granulator starts getting particularly noisy, or when the ground material starts getting dusty, the rotor knives are no longer in good condition. It is time to sharpen them. To achieve this operation, follow the steps below.

- 1 Check the orientation of the fixed knives** so that they can meet the movable rotor knives properly.
- 2 Replace the rotor knives** if any metal parts accidentally go inside the granulator, thereby causing chipping of the cutting edge.
- 3 Sharpen the rotor knives** according to the indications shown in the picture. The picture shows the angles required to achieve the best cutting conditions and preserve the rotor knives rotation length.

It should be noted that, if sharpening is not carried out according to these indications, the yield of the machine could decrease in terms of quality and productive capacity.

In order to avoid overheating the material with subsequent loss of hardness and toughness, sharpening should be carried out with plenty of cooling.

Assembly and Adjustment of Clearance between the Rotor Knife and Fixed Knives

Install the rotor knives and fixed knives by following the disassembly procedure in reverse order. Do not tighten the screws.

IMPORTANT: Wear proper cut-resistant gloves. **Do not test the cutting edge of the rotor knives, even when wearing gloves.**

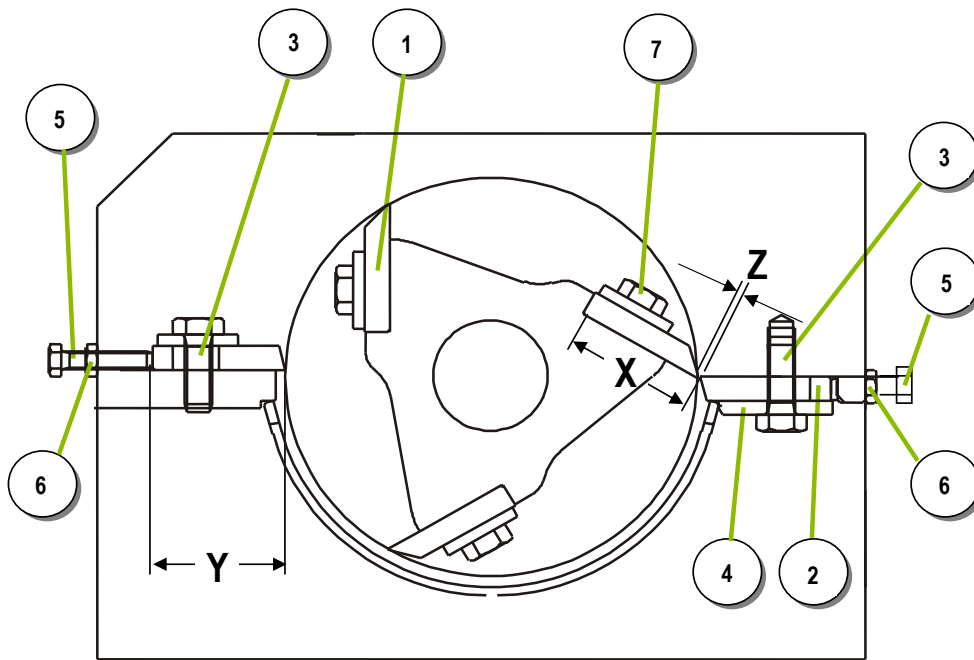

IMPORTANT: In order to guarantee a constant rotor knives rotation length, the movable rotor knives (1) (which are all sharpened at the same length), should be perfectly tight against the shaft shoulder. Then, tighten the screws (7) with a torque wrench.

The distance between the rotor knives and fixed knives is based on the type of cutting. For standard cutting, distance (Z) is 0.008 - 0.010 in. {0.20 - 0.25 mm}. For trim cutting (fixed knife with double chamber), distance (Z) should be 0.003 - 0.004 in. {0.08 - 0.10 mm}. Distance (Z) is achieved by adjusting the fixed knives with the set screws (5) and lock screws (6) before ultimately tightening the screws (3) with the torque wrench.

NOTE: "trim cutting" fixed knife with double chamber is lesser used optional configuration

Torque Bolts

Make sure all bolts and nuts are tightened by using a torque wrench.

Movable rotor knives are screwed to the rotor. It is important to check periodically if these screws are tight in order to prevent the rotor from jamming due to collisions between the rotor knives and fixed knives.

- 1** Manually and slowly turn the rotor assembly to check if it is free.
- 2** Close all the parts again and get the machine ready for operation.

Assembly and Adjustment of Clearance between the Rotor Knife and Fixed Knives (Continued)

Rotor Knives and Fixed Knives Fastening Screws Technical Features

Adjustment and torque table. Use a torque wrench to tighten the grade 8.8 bolts.

Rotor knives = M12 X 35 mm grade 8.8 tightening torque 79 N·m

Fixed knives = M12 X 35 mm grade 8.8 tightening torque 79 N·m

	Ms (lb-in.)	Ms (lb-ft.)	Ms (N·m)
M12	699	58	79

Bearing Greasing

! IMPORTANT:

Refer to Section “ATTENTION: Read This So No One Gets Hurt..” and read it carefully.

In order to carry out this operation, the bearing housings have been supplied with grease fittings.

NOTE: The following picture shows an example. Please refer to the drawings shipped with your equipment.

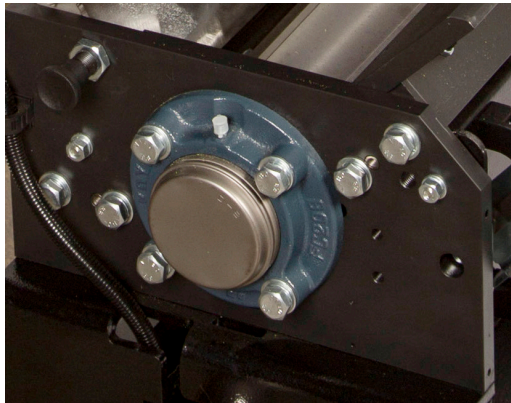

Proceed as follows:

- 1 Use the emergency stop switch in order to prevent the machine from starting up** (due to accidental operations) when the power is switched on.
- 2 Use the grease fittings as shown in the picture only when you are sure that the machine is not running.**
- 3 Inject the grease into the grease fittings.**
- 4 Periodically (every 4 - 6 months) grease the bearing housings with multi-use lithium EP-1 grease or equivalent** according to the features specified in the table:

Thickening agent (soap)	Lithium
Basic oil	Mineral
Consistency (NLGI)	3
Operating temperature range	-22 - 248°F { -30 - + 120°C }
Rust preventer additives	
Good water resistance	

Bearing Greasing (Continued)

IMPORTANT: Be careful when using grease: avoid contact with eyes. Do not disperse into the environment.

Refer to the "Troubleshooting" section of this manual.

Never grease before the first startup (unless otherwise specified). Thoroughly clean the grease fitting before each lubrication. Gently introduce the grease. If possible, slowly turn the shaft with gloved hands.

Over-greasing is harmful. It is preferred to grease frequently and in small quantities (about 0.35 oz { 10 gr}). Never lubricate with oil - just grease. Do not mix different greases.

Greasing should be carried out with machine not running, and disconnected from power.

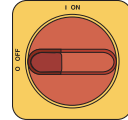

5 Close all the parts and reset electrical connections.

It is recommended to use only the required amount of grease. Do not use too much grease. If necessary, remove excess lubricant, grease, or redundant graphite with a proper cloth.

Exceeding or lack of lubricant may cause inconsistent machine operation.

Use only recommended lubricants or lubricants with equivalent features. Lubricants should be qualitatively known and tested.

Grease Fittings

Inject the grease in the grease fittings with a proper pump until greasing is completed. The periodicity of greasing also depends on the operating conditions of the machine. The type of grease to be used is specified on the previous page.

Ball Bearings

The ISO 281 Standards rates the endurance of a rolling bearing according to the number of revolutions it can reach before any fatigue phenomena start to occur on one of its races or rolling parts.

Identical and functional bearings (both those to be tested in a lab and those used for practical purposes) used in identical conditions, may have different endurance.

Contact Conair
Parts and Service
Phone: 800-458-1960.
From outside of the
United States,
Call: 814 437 6861.

Drive Belt Inspection



DANGER:

Make sure power is OFF. Accidental startup can result in serious injury.

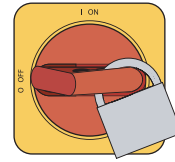

Belt Replacement

- 1 Lockout.**
- 2 Belts must be replaced by qualified personnel only.**
- 3 Replace belts only when belt drive is NOT running and power is disconnected.**
- 4 Make sure the electric power is off.**
- 5 Reduce the distance between the pulleys by sliding the motor and by loosening the four bolts (A) and the counter-pressure screws (B) .**
- 6 Remove belts to be replaced.**
- 7 Always replace all belts at the same time with belts of the same specifications.**
- 8 Always install all required belts.**
- 9 Use the same belts as those supplied with the machine.** If that is not possible, make sure that: the cross-section of the belt is suitable and can be used with the pulley (the belt is, to a feasible extent, as long as the original belt).

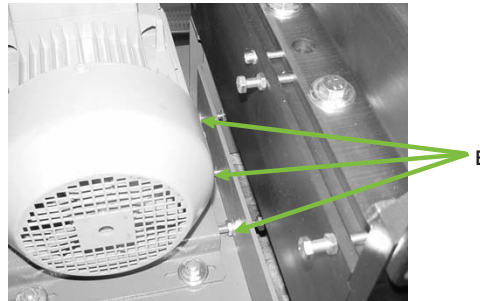
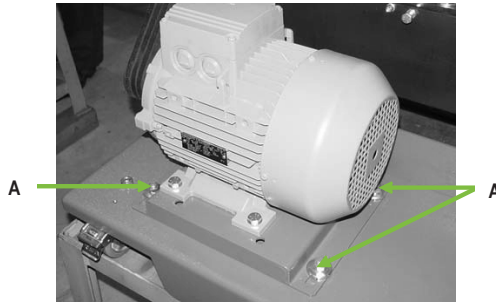

NOTE: The following picture shows an example. Please refer to the drawings shipped with your equipment.

Contact Conair
Parts and Service
Phone: 800-458-1960.
From outside of the
United States,
Call: 814 437 6861.

Drive Belt Inspection (Continued)

Belt Installation

Before positioning the belts on the pulleys, check the following:

- Wear of pulley grooves. If the grooves are worn, it is highly recommended they be replaced. Otherwise, the belts will quickly start to deteriorate.
- Cleanness of the sides of the pulley grooves which could have traces of oil or sediment.

When installing, the belt should not be forced into the pulley grooves with a tool. Generally, for easy installation, just reduce the distance between the pulleys or the tension of the tightener; otherwise, it will be necessary to remove at least one of the pulleys.

To ensure proper operation and avoid an untimely failure, the belts should be stored without any heavy creases and should not be exposed to extremely high or low temperatures or to high dampness.

Each drive should be protected to ensure the safety of persons and to prevent abrasive or improper material from damaging the pulleys.

Install the belts by following the above-mentioned disassembly procedure in reverse order.

Drive Tensioning

- Pulley alignment. Perfect alignment should be achieved in order to increase belt life.
- The best tension is the lowest that does not make the belt slip under maximum load conditions.
- Frequently check the tension during the first 24/48 running-in hours.
- Overtensioning can reduce life of the belt and of the bearings.
- Keep belts free from any improper material which may cause slippage.
- Check drive periodically. Tension it when it starts slipping.

Use the following procedure to check the tension of conventional drives:

1 Measure the length of the free portion (t).

Deflection, belt = 0.12 in. { 3 mm }.

Deflection force first assembly = 6.07 lbf { 27 N }.

Max Force of the deflection (re-tensioning) = 5.40 lbf { 24 N }.

Contact Conair
Parts and Service
Phone: 800-458-1960.
From outside of the
United States,
Call: 814 437 6861.

Taper-lock Bushing

ASSEMBLY

Screw when being tightened



DISASSEMBLY

Loosen tightening screw

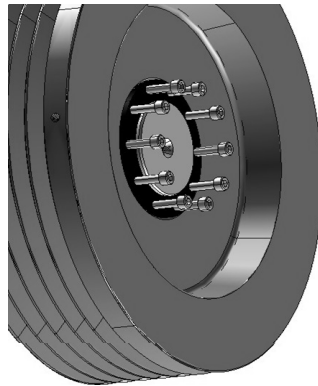

 **NOTE:** The following picture shows an example. Please refer to the drawings shipped with your equipment.

A taper-lock bushing is a connection component that allows a driving transmission. The granulator is equipped with a taper-lock bushing mounted on the flywheel pulley.

This is a self-centering taper-lock bushing.

Removal Instructions

- 1 Loosen and remove all tightening screws.**
- 2 Fit the screws in the front cone removal threading.**
- 3 Gradually tighten the screws in a crisscross sequence** until the first cone is freed.
- 4 Manually tighten the screws** until they start to oppose resistance again.
- 5 Gradually tighten the screws again in a crisscross sequence** until the second cone is freed, hence freeing the whole self-locking element.
- 6 Take the taper-lock bushing off the shaft and off the hub.**

Reusing the Taper-lock Bushing

- 1 Thoroughly clean the taper-lock bushing surfaces.**
- 2 Slightly oil the surfaces.**
- 3 Reinstall the cones in their original position.** Make sure the removal threading matches the flat reaction surface.
- 4 Repeat the same assembly and disassembly procedures.**

Taper-lock Bushing (Continued)

Installation Instructions

- 1** Thoroughly clean the contact surfaces of the shaft and hub and then apply a thin film of fluid mineral oil on them.
- 2** Make sure the tolerances fall within the permissible range (h8/H8), and then fit the self-locking element between the shaft and hub. Make sure the adjustment of the slots of the tightening cones are opposed to the right and to the left and adjust the shell slots downwards.
- 3** When the hub shows a centering base, **loosen all screws before installing the element in the housing.** Remove two screws and fit them in the removal threading in order to move the two cones away as far as possible. By doing so, the assembly and disassembly operations will be easier. Before starting to tighten, remember to put the two screws back into their holes.
- 4** Manually tighten the screws until the cones contact the shaft and the outer ring contacts the hub.
- 5** Tighten the screws in a crisscross sequence by using a calibrated torque wrench. Continue until you reach 50% of the torque value specified for the screws in the table (see Figure 1).
- 6** Repeat the same operation in a crisscross sequence and with torque wrench calibrated at 100% of the value specified in the table.
- 7** Check again if the torque of the screws is equal to the torque shown in the table by executing 2.5 revolutions clockwise (see Figure 2).
- 8** When the two and a half revolutions have been executed to tighten the screws at their rated torque, the torque wrench (calibrated at 60% of the rated tightening torque value) must trigger.

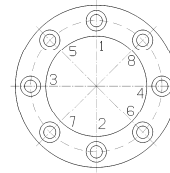

Figure 1

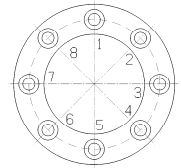

Figure 2

No other additional action is required after this operation.

Coarse Pitch Screws CLASS 12.9		
Mean Friction Factor $\mu=0.14$		
Coarse pitch	MA (lb-ft.)	MA (N·m)
M 6	1.3	1.7
M 8	3.0	4.1
M 10	6.1	8.3
M 12	10.7	14.5
M 14	17.0	23.0
M 16	26.2	35.5
M 18	35.8	48.5
M 20	50.9	69.0
M 22	68.6	93.0
M 24	88.5	120
M 27	132.8	180
M 30	177.0	240

LEGEND:

MA = (Deca-newton, N·m meters)

12.9 = Class unified by screw manufacturers according to the material resistance values.

Hopper Tilt/Open Sequence

Before tilting the hopper, perform the following steps.

- 1 Stop the granulator by means of the wheel with brake (1).**
- 2 Release the screw (2) from the safety microswitch to open the hopper.**
- 3 Open the latches (3).**
- 4 Carefully tilt the hopper (4).**

 **NOTE:** The following picture shows an example. Please refer to the drawings shipped with your equipment.

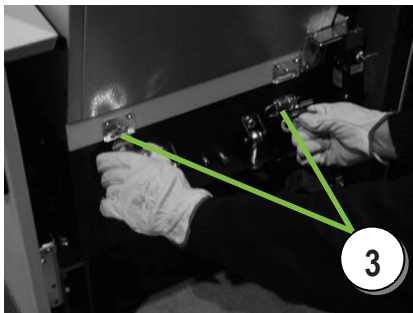
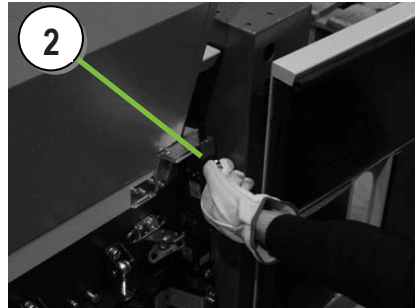

ATTENTION: Wait until the machine is cool before beginning maintenance.

Hopper Tilt/Open Sequence (Continued)

Closing the Hopper

- 1** Reset the microswitch using the reset button.
- 2** Press the start button on the electric panel to restart the machine.



WARNING:

Before operating the actuator for the hopper lifting, be sure that the stay bolts are completely released.

- 3** Cover the cutting chamber in order to prevent material or tools from accidentally falling inside of it.
- 4** Clean the hopper (vacuum lodged material) without striking it, deforming it, or scraping it. Use a bag to collect scrap (do not scatter it).
- 5** Always make sure that the machine is stable and that, when moving the hopper, it cannot strike anything or anyone.
- 6** Remove the covering on the cutting chamber and clean the chamber with an aspirator.



NOTE: If the machine is provided with an insulation box, open it and proceed as described above

Bin Removal Sequence

Before removing the bin, carry out the following procedure as in previous maintenance sections.

- Press the stop button to stop the machine. Press the E-stop.
- Unlock the microswitch using the button on the electric panel.
- Wait until the indicator for unlocking the microswitch switches ON (the time is set by the manufacturer).
- Close the main switch after opening the removable guards.



NOTE: The following picture shows an example. Please refer to the drawings shipped with your equipment.

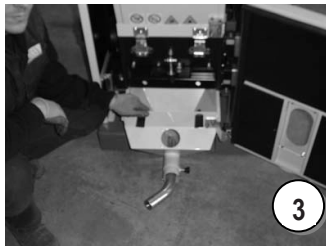
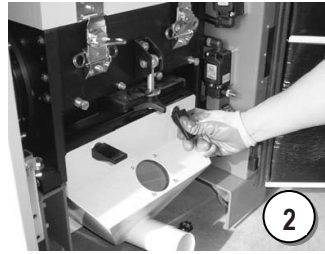
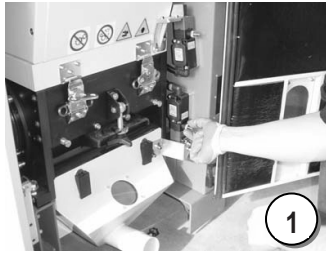

- 1** Release the screw (1) from the safety microswitch.
- 2** Release the expansion lockups (2).
- 3** Pull out the collecting loader/bin (3).
- 4** Loosen the handwheel (4).
- 5** Open the screen-holder (5).
- 6** Pull out the sorting screen (6).

Bin Removal Sequence (Continued)

The screen-holder opening is cushioned by a gas piston placed on the housing.

 **NOTE:** The following picture shows an example. Please refer to the drawings shipped with your equipment.

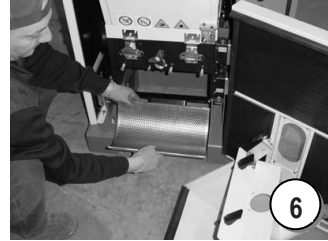

7 Clean the screen-holder (eliminate stuck material) without striking it, deforming it, or scraping it.

8 Clean the screen without scratching it or deforming it.

 **NOTE:** If the machine is provided with an insulation box, open it and proceed as described above.

Repositioning the Bin

1 Reposition the bin and fasten it.

2 Reset the microswitch using the reset button.

3 Press the machine start button on the electric panel to restart the machine.

Checking the Circuit Breaker

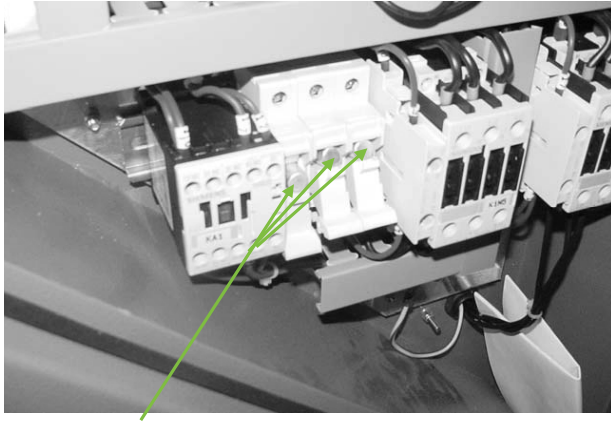

 **NOTE:** The following picture shows an example. Please refer to the drawings shipped with your equipment.

The intervention of the control circuit protective circuit breaker means that an anomaly has occurred and has caused an excessive electric current absorption. Therefore, it is necessary to identify and solve the problem that has caused this anomaly and replace the tripped circuit breaker.

Follow the steps below to carry out this operation.

- 1 Press the the stop button.**
- 2 Use the main lockout in order to prevent the machine from starting up** when the power is switched on.
- 3 Open the electric control panel.** Check for a tripped breaker.
- 4 Flip any circuit breaker that has tripped.**
- 5 Put back all parts.**
- 6 Reset the stop button.** Make sure the start switch is off (OFF position).

The granulator can be started only after properly removing all material residues from the cutting chamber.

Cutting Chamber Cleaning

 **NOTE:** The following picture shows an example. Please refer to the drawings shipped with your equipment.



Every time different color material is used, thoroughly clean the screen cutting chamber as well as the bin with compressed air and/or with an aspirator.

In order to access the cutting chamber, *see “Hopper Tilt/Open Sequence”, and “Bin Removal Sequence” in this section of the manual.*

 **NOTE:** Do not put objects in the cutting chamber: introduce only the opening of the aspirator.



DANGER:

Rotor knives are sharp and fragile. Keep hands and body away from the rotor knives. If needed, turn the shaft with a softwood board.

IMPORTANT: Wear proper cut-resistant gloves. Do not test the cutting edge of the rotor knives, even when wearing gloves.

- 1** Remove any material twisted around the ends of the shaft with pliers or tongs.
- 2** Keep the shaft from accidentally turning by using a block made of soft wood.
- 3** Install the screen again (every time the rotor knife is sharpened, turn the screen to prevent the holes from being ovalized and eventually replaced).
- 4** Close the screen-holder.
- 5** Reposition the collecting bin (make sure it is empty).
- 6** Make sure that the cutting chamber is empty and that the rotor knives are properly positioned and in good condition.
- 7** Close the hopper and make sure that its supporting surface is clean.
- 8** Make sure that all guards are in place and fully functional. Otherwise, stop and replace or repair them.

Replacing the Flaps



 **NOTE:** The following picture shows an example. Please refer to the drawings shipped with your equipment.

To make the replacement of the flap :

- 1 Loosen the fixing nuts.**
- 2 Remove the stay plate.**
- 3 Withdraw the plastic flap.**
- 4 Flaps are fastened with bi-adhesive hook-and-loop fasteners. Before replacing the flap, remove the fasteners inside the hopper and clean the sheet metal part with detergent.**
- 5 Apply the adhesive side and fasten the flap.**

Contact Conair
Parts and Service
Phone: 800-458-1960.
From outside of the
United States,
Call: 814 437 6861.

Troubleshooting

Before Beginning	6-2
A Few Words of Caution.....	6-2
Identifying the Cause of a Problem	6-3
Process Problems.....	6-4
Mechanical Problems	6-5
Electrical Problems	6-6

Before Beginning

You can avoid most problems by following the recommended installation, operation, and maintenance procedures outlined in this User Guide. If you have a problem, this section will help you determine the cause and tell you how to fix it.

Before you begin troubleshooting:

Additional manuals and prints for your Conair equipment may be ordered through the Customer Service or Parts Department for a nominal fee. Most manuals can be downloaded free of charge from the product section of the Conair website. www.conairgroup.com

- Find any wiring, parts, and assembly diagrams that were shipped with your equipment. These are the best reference for correcting a problem. The diagrams will note any custom features or options not covered in this User Guide.
- Verify that you have all instructional materials related to the granulator. Additional details about troubleshooting and repairing specific components are found in these materials.
- Check that you have the manual(s) for other equipment connected in the system. Troubleshooting may require investigating other equipment attached to, or connected with the granulator.

A Few Words of Caution



WARNING: Improper installation, operation, or servicing may result in equipment damage or personal injury.

This equipment should only be installed, adjusted, and serviced by qualified technical personnel who are familiar with the construction, operation, and potential hazards of this type of machine.

All wiring, disconnects, and fuses should be installed and adjusted by qualified electrical technicians in accordance with electrical codes in your region. Always maintain a safe ground. Do not operate the equipment at power levels other than what is specified on the machine serial tag and data plate.



WARNING: Electrical hazard



Before performing maintenance or repairs on this product, disconnect and lock out electrical power sources to prevent injury from unexpected energization or start-up. A lockable device has been provided to isolate this product from potentially hazardous electricity.



DANGER: Sharp Rotor Knives

Most injuries caused by rotor knives occur when the granulator has been turned off. Handle rotor knives with care at all times.

- Always wear cut-resistant gloves when the granulator chamber is open and when handling rotor knives.
- Always lock out power to the granulator before opening the granulator chamber.



DANGER: Pinch Hazard

Injuries when lowering the hopper.



When the hopper is being lowered, keep hands and arms away from the hopper/granulator surfaces.

Identifying the Cause of a Problem

The Troubleshooting section covers problems directly related to the operation and maintenance of the granulator. This section does not provide solutions to problems that originate with other equipment. Additional troubleshooting help can be found in manuals supplied with the other equipment.

The main problems you will see with the granulator are:

- **Process concerns.**
- **Mechanical problems.** This section contains problems that may be related to operation of the granulator.
- **Electrical problems.**

Additional troubleshooting help can be found in the documentation manuals included with this User Guide.

Process Problems

Look in this section when you have problems such as rotor blockage.

Symptom	Possible Cause	Solution
A) Rotor blockage	1) Overfeeding. 1a) Cutting chamber clogged. 2) Introduction of material other than plastic. 3) Discharge device clogged. 4) Screen clogged. 5) Bearing(s) seized. 6) Inadequate tension of drive belts.	Reduce feeding capacity. Clean chamber. Grind only plastic materials. Empty discharge device. Remove screen, clean it, and make sure it is not damaged. Replace bearing(s). Check belt tension, adjust belt tension, and check motor slide bolts.
B) Abnormal dusty ground material	1) Rotor knives inadequately sharpened. 2) Rotor knives sharpened with wrong angles. 3) Deteriorated screen. 4) Excessive clearance between rotor knives and fixed knives. 5) Wrong direction of motor rotation.	Re-sharpen or replace rotor knives. Re-sharpen or replace rotor knives. Replace screen. Check clearance and adjust, if necessary. Check direction of rotation and, if necessary, modify the electrical connections.
C) Overheated material	1) See points: A3. B1 - B2 - B3. 2) Screen with holes too small. 3) Cooling circuit is interrupted or obstructed.	See points: A3. B1 - B2 - B3. Call Technical Service. Check the continuity of the cooling system.
D) Reduction of productivity	1) See points: B1 - B3 - B4.	See points: B1 - B3 - B4.
E) Flyback	1) Flaps damaged.	Replace flaps. Call Technical Service.

Mechanical Problems

Look in this section when the final product does not meet standards: cracks in rotor knives or breakage of rotor knives.

Symptom	Possible Cause	Solution
A) Bearings overheated	1) Excessive tension of belts.	Check belt tension and, if necessary, adjust.
	2) Inadequate lubrication.	Lubricate housings properly.
B) Cracks in the rotor knives or breakage of rotor knives	1) Cutting of prohibited material.	Call Technical Service. Replace rotor knives.
	2) Improper sharpening.	Replace rotor knives.
	3) Rotor knife/fixed knife mechanical interference.	Replace rotor knives.
C) Rotor knives moving from their housings	1) Abnormal support of rotor knives.	Clean the supporting surface of the rotor knives.
	2) Loose rotor knife fastening bolts.	Tighten the bolts properly.
	3) Stretched rotor knife fastening bolts.	Replace bolts with new identical bolts and torque appropriately.
D) Excessive rotor knife wear	1) Cutting of prohibited material.	Call Technical Service. Sharpen or replace rotor knives.
E) Screen-holder not locked	1) Wrong positioning of screen.	Remove and re-position screen.
F) Incomplete hopper lockup	1) Supporting surface not clean.	Clean supporting surface.
G) Excessive noise	1) Worn rotor knives.	Sharpen rotor knives and, if necessary, replace them.
	2) Overfeeding.	Reduce feeding rate.
	3) Flaps damaged.	Replace flaps. Call Technical Service.
	4) Cutting of prohibited material.	Call Technical Service.
	5) Rotor knives and fixed knives contact.	Check rotor knife - fixed knife clearance and, if necessary, adjust, sharpen, or replace rotor knives.
H) Vibrations	1) Rotor knives not sharpened.	Sharpen rotor knives.
	2) Shaft is unbalanced.	Call Technical Service.
	3) Bearings are worn-out or not lubricated.	Call Technical Service. Lubricate housings.

Electrical Problems

Look in this section when you have problems such as rotor blockage.

Symptom	Possible Cause	Solution
A) Motor does not start	1) Safety microswitch.	Check bin microswitch. Call Technical Service.
	2) Electric power failure.	Check and, if necessary, replace fuses or reset automatic switch (if equipped).
	3) Motor contactor not powered.	Check main line and auxiliary circuits safety devices.
	4) Emergency push-button pressed.	Reset emergency push-button.
	5) Thermal relay and automatic devices triggered.	Reset: in case of recurring triggering, check operating current and, if necessary, call Technical Service.
B) Excessive motor absorption	1) Overfeeding	Reduce feed rate.

We're Here to Help

Conair has made the largest investment in customer support in the plastics industry. Our service experts are available to help with any problem you might have installing and operating your equipment. Your Conair sales representative also can help analyze the nature of your problem, assuring that it did not result from misapplication or improper use.

How to Contact Customer Service

To contact Customer Service personnel, call:



 **NOTE:** Normal operating hours are 8:00 am - 5:00 pm EST. After hours emergency service is available at the same phone number.

From outside the United States, call: 814-437-6861

You can commission Conair service personnel to provide on-site service by contacting the Customer Service Department. Standard rates include an on-site hourly rate, with a one-day minimum plus expenses.

Before You Call...

If you do have a problem, please complete the following checklist before calling Conair:

- Make sure you have all model, control type from the serial tag, and parts list numbers for your particular equipment. Service personnel will need this information to assist you.
- Make sure power is supplied to the equipment.
- Make sure that all connectors and wires within and between control systems and related components have been installed correctly.
- Check the troubleshooting guide of this manual for a solution.
- Thoroughly examine the instruction manual(s) for associated equipment, especially controls. Each manual may have its own troubleshooting guide to help you.

Additional manuals and prints for your Conair equipment may be ordered through the Customer Service or Parts Department for a nominal fee.

Most manuals can be downloaded free of charge from the product section of the Conair website.

www.conairgroup.com

Equipment Guarantee

Conair guarantees the machinery and equipment on this order, for a period as defined in the quotation from date of shipment, against defects in material and workmanship under the normal use and service for which it was recommended (except for parts that are typically replaced after normal usage, such as filters, liner plates, etc.). Conair's guarantee is limited to replacing, at our option, the part or parts determined by us to be defective after examination. The customer assumes the cost of transportation of the part or parts to and from the factory.

Performance Warranty

Conair warrants that this equipment will perform at or above the ratings stated in specific quotations covering the equipment or as detailed in engineering specifications, provided the equipment is applied, installed, operated, and maintained in the recommended manner as outlined in our quotation or specifications.

Should performance not meet warranted levels, Conair at its discretion will exercise one of the following options:

- Inspect the equipment and perform alterations or adjustments to satisfy performance claims. (Charges for such inspections and corrections will be waived unless failure to meet warranty is due to misapplication, improper installation, poor maintenance practices, or improper operation.)
- Replace the original equipment with other Conair equipment that will meet original performance claims at no extra cost to the customer.
- Refund the invoiced cost to the customer. Credit is subject to prior notice by the customer at which time a Return Goods Authorization Number (RGA) will be issued by Conair's Service Department. Returned equipment must be well crated and in proper operating condition, including all parts. Returns must be prepaid.

Purchaser must notify Conair in writing of any claim and provide a customer receipt and other evidence that a claim is being made.

Warranty Limitations

Except for the Equipment Guarantee and Performance Warranty stated above, Conair disclaims all other warranties with respect to the equipment, express or implied, arising by operation of law, course of dealing, usage of trade or otherwise, including but not limited to the implied warranties of merchantability and fitness for a particular purpose.

Glossary

Granulator:

Equipment that cuts material inside the cutting chamber, thereby reducing its size until the product goes into the evacuation bin through appropriately sized screen holes.

Cutting chamber:

Equipment area where material is cut/reduced.

Feeding devices:

Feeding may occur manually through an opening, or automatically through devices installed on the equipment or connected to it. Automatic feeding occurs through devices such as, auger screws, belts, etc., or by means of suction systems, etc., or traction units located upstream.

Evacuation devices:

Devices receiving granulated material or finished products. Discharge may occur by the force of gravity or devices such as auger screws, belts, etc., or through suction, blowing, etc.

Rotor:

Rotary cutting device with blades installed inside the cutting chamber.

Fixed knives:

Fixed knives installed inside the cutting chamber.

Rotor knives:

Tool used for cutting material attached to the rotor.

Screen:

Drilled plate usually located in the cutting chamber evacuation bin. It is used for allowing the granulated material or appropriately sized finished product to pass through.

Working area:

A place where the operator feeds the machine.

Loading surface:

A surface used for preparing the material to be fed into the granulator. The person in charge of feeding the machine must not stand on this surface. (If it is possible to stand on this surface, it should be considered a working surface.)

Connecting Accessories and Options

In many instances, your Viper granulator has additional features or is connected to other devices. This appendix gives further information about the control logic, and the electrical connections features and accessories such as: rotor brake, in feed conveyors, metal detectors, high-level discharge, optional alarm lights and horns, under-speed relay, blowers, and loading/conveying options.

Please refer to this appendix as you connect and operate these accessories/options. Contact Conair's Customer Care department with any questions.

Contact Conair
Parts and Service
Phone: 800-458-1960
From outside of the
United States,
Call: 814 437 6861

Granulator Logic

When the rotor motor is stopped (M1), the M1 normally closed (N.C.) contact in the Unlock circuit gives the permission to unlock all safety interlock switches. When the Unlock pushbutton is depressed, the R1 relay latches and the Unlock Light will flash (flasher timer). After the On-delay Safety relay (Pilz-PZA) times out (60 seconds), the Unlock Light will change from flashing to solid and the power will be supplied to safety interlock switches. Feedback from the safety interlock switches will enable the Hopper Open Motor circuit (Series 17 and 23).

For the Viper Granulators equipped with a rotor brake:

An Unlock signal is sent to the rotor brake (just like the Screen Access and Hopper Access keyed interlock switches).

To open the machine:

1 Stop the granulator rotor motor.

2 Push the “Unlock” button. This starts the 60 second timer.

 **Note:** This is considered the “spin-down” timer for the machine. The timer setting is approximately 60 seconds. The timer value may vary by machine since it is rotor inertia dependent.

3 With the spin-down complete, the control provides power to the key interlock solenoids, unlocking those switches.

 **Note:** The safety key interlocks do not need to have power to insert the key - only to release the key.

4 With key interlocks “un-locked”, manually remove the discharge bin, open the screen cradle, perform hopper tilt, and release the rotor brake brackets if equipped.



 **Note:** Once one of the key actuators have been removed from the interlock switch, the rotor and any auxiliary motors cannot run - only the Hopper Lift motors will run (Series 17 and 23).

5 Press the E-stop to turn off the control power then perform the required “lock-out/tag-out” prior to putting any tools on/in the machine.

6 Perform the maintenance / service required for the machine.

Options

To close the machine:

- 1 Close screen cradle and return the rotor brake back to the safe position** (Series 17 and 23).
 **Note:** The safety key interlocks do not need to have power to insert the key - only to release the key.
- 2** If applicable, **remove the “lock-out/tag-out” and turn on main power supply.**
- 3** If the E-stop was depressed earlier, **pull the E-stop out to enable machine.**
- 4 Close the hopper (if powered open/close style).** Otherwise, hopper can be closed in Step 5.
 **Note:** No motors will run as long as the key actuators are NOT in safety interlocks.
- 5 Lock all latches and confirm all safety items pass inspection.**
- 6 The downstream equipment and the granulator rotor motors can now be started.**

High-amp Option (used to stop the In-Feed conveyors):

The ammeter has two outputs, Set-Point 1 (SP1) and Set-Point 2 (SP2). The first set-point is the WARNING or the first high amp limit which is approximately 66% of FLA of the rotor motor. The second set-point is the HIGH amp limit. This usually has a set-point of approximately 80% FLA of the rotor motor. These two signals are wired in a configuration so the High amp alarm turns on an alarm and the contact stops the in-feed conveyor momentarily. The alarm turns off when the WARNING level signal stops. This creates a window for “stopping” the in-feed conveyor until the FLA drops down to the WARNING level - or about 66% of the FLA of the rotor motor. Once below the WARNING level, the in-feed conveyor restarts automatically.

Metal Detector on the In-feed Conveyor:

The metal detector on the in-feed conveyor is typically a Sesotec. A signal from the metal detector can represent the metal detector is OK, or the Metal Detector is OK and there is no metal. These signals are dry contacts from the metal detectors relay output. They are typically normally closed (N.C.). They remain closed by the “OK” and “No Metal” logic, opening when there is a fault on the detector or when there is metal present. This signal ties in to the in-feed conveyor and stops the conveyor from moving. It requires some action from an operator to re-start the conveyor. The action is set in the metal detector. Refer to the metal detector operator’s manual for details.

High Level Bin Discharge (Directed to the optional tower light [custom] or alarm horn):

This can be proximity or a rotary level switch. Some of the bin configurations under the granulator warrant two level switches: one for each side of the two part compartmentalized bin. When the level exceeds the bin's capacity, an alarm light is lit and the in-feed conveyor is stopped. The rotor can be set up by the user to stop by removing a jumper on the contacts of the R7 relay. The rotor and in-feed conveyor must be restarted by operator.

Surge Bin High Level:

The surge high level option turns on surge bin high level light and turns the in-feed conveyor off. This is available on custom control panels only and is achieved by adding a relay (R11) and an alarm light.

Under-speed Relay:

The under-speed relay provides protection from the rotor slowing down under a large load. This protects the rotor motor from overheating and belt over-slippage. It is typically set for 50% of the nominal speed of the rotor. The low RPM alarm can be set to activate the R5 relay and drop out the rotor motor circuit. It includes a Low RPM Alarm Reset pushbutton.

Starting Order of Granulator and Associated Loading and Evacuating Auxiliary Equipment:

Downstream first:

- 1** Size reduction blower (SRB) or discharge blower;
- 2** Rotor; and
- 3** In-feed conveyor

Optional Purge Button (on some Granulators):

This is a momentary pushbutton that allows the customer to wire directly into their Loading/Conveying system terminal blocks. The pushbutton has a normally open (N.O.) and a normally closed (N.C.) contact. It provides a means to evacuate the granulator bin.

Viper 8 Series Recommended Spare Parts

VIPER 813	Part Number
ROTOR KNIVES	72501604
FIXED KNIVES	72501603
ROTOR KNIVES TC COATED	725016041
FIXED KNIVES TC COATED	725016031
KNIFE HARDWARE (ROTOR AND FIXED)	725018012
KNIFE WASHERS (ROTOR ONLY)	725018048
DRIVE BELT	725018017
SAFETY SWITCH	725018004
VIPER 817	
ROTOR KNIVES	72501606
FIXED KNIVES	72501605
ROTOR KNIVES TC COATED	725016061
FIXED KNIVES TC COATED	725016051
KNIFE HARDWARE (ROTOR AND FIXED)	725018012
KNIFE WASHERS (ROTOR ONLY)	725018048
DRIVE BELT	725018017
SAFETY SWITCH	725018004

Contact Conair
 Parts and Service
 Phone: 800-458-1960
 From outside of the
 United States,
 Call: 814 437 6861

