



USER GUIDE  
UGG009/1103

# CW Granulators



**INTRODUCTION** • Introduction • **TECHNICAL SPECIFICATION** • Dimensions • Types of cutter housings • Data • Sound level • **FUNCTION DESCRIPTION** • General • Safety system • Main switch • Emergency stop • Cutter lock • Safety switches • Standstill monitor • Important parts which belongs to the granulator • safety system • Before the granulator can be started • **SECURITY** • Safety system • Markings on the granulator and optional equipment that stipulate caution • Parts of the safety system • Important parts belonging to the safety system of the granulator • Functional description of parts of the safety system • Emergency stop • Cutter lock • Safety switches • Standstill monitor • Safety instructions • Safety instructions and safety measures during operation

Please record your equipment's model and serial number(s) and the date you received it in the spaces provided.

It's a good idea to record the model and serial number(s) of your equipment and the date you received it in the User Guide. Our service department uses this information, along with the manual number, to provide help for the specific equipment you installed.

Please keep this User Guide and all manuals, engineering prints and parts lists together for documentation of your equipment.

Date:

---

Manual Number: UGG009/1103

---

Serial Number(s):

---

Model Number(s):

---

**DISCLAIMER:** The Conair Group, Inc., shall not be liable for errors contained in this User Guide or for incidental, consequential damages in connection with the furnishing, performance or use of this information. Conair makes no warranty of any kind with regard to this information, including, but not limited to the implied warranties of merchantability and fitness for a particular purpose.

# Table of Contents

<b>1.</b>	<b>Introduction</b>	
	Introduction .....	1-2
<b>2.</b>	<b>Technical specification</b>	
	Dimensions .....	2-2
	Types of cutter housings .....	2-2
	Data .....	2-3
	Sound level .....	2-4
<b>3.</b>	<b>Function description</b>	
3.1	General .....	3-2
3.2	Safety system .....	3-5
	– Main switch .....	3-5
	– Emergency stop .....	3-6
	– Cutter lock .....	3-6
	– Safety switches .....	3-6
	– Standstill monitor .....	3-7
	– Important parts which belongs to the granulator safety system .....	3-7
	– Before the granulator can be started .....	3-7
<b>4.</b>	<b>Security</b>	
4.1	Safety system .....	4-2
	– Markings on the granulator and optional equipment that stipulate caution .....	4-2

–	Parts of the safety system . . . . .	4-3
–	Important parts belonging to the safety system of the granulator . . . . .	4-3
4.2	Functional description of parts of the safety system . . . . .	4-4
–	Emergency stop . . . . .	4-4
–	Cutter lock . . . . .	4-4
–	Safety switches . . . . .	4-4
–	Standstill monitor . . . . .	4-5
4.3	Safety instructions . . . . .	4-6
–	Safety instructions and safety measures during operation . . . . .	4-6
–	Safety instructions and safety measures concerning the electrical system . . . . .	4-7
–	Safety instructions and safety measures with regard to cleaning, maintenance and service . . . . .	4-7
4.4	Personal safety equipment . . . . .	4-10
–	Ear protection . . . . .	4-10
–	Protective gloves . . . . .	4-10
–	Protective goggles . . . . .	4-10
4.5	Safety instructions and caution when changing knives . . . . .	4-11
–	Length, dimensions and strength class on screws . . . . .	4-12
–	Tightening torque and torque wrench . . . . .	4-12
–	Tips for installation of knives . . . . .	4-12

## 5. Installation

5.1	Place of use . . . . .	5-2
–	Floor, foundation, place of use . . . . .	5-2
–	Safety distance when opening the hopper . . . . .	5-2
5.2	Install the hopper . . . . .	5-3
5.3	Install the front inlet part . . . . .	5-5
5.4	Electrical connection . . . . .	5-6
–	Location of the electrical cabinet . . . . .	5-6
–	Check the direction of rotation of the granulator motor . . . . .	5-6
–	Check the direction of rotation of the blower motor . . . . .	5-7
–	Check the direction of rotation of the optional equipments . . . . .	5-7
–	If any direction of rotation is wrong . . . . .	5-7

5.5	Installation	5-8
	– Adjust the granulator stand	5-8
5.6	Actions before the first start	5-9
	– Clean the granulator from anticorrosive agent	5-9
	– Check before the first start	5-9
5.6.1	Two hours after first start	5-9
5.6.2	20 - 30 hours after first start	5-10
5.7	Open the cutter house door, hopper, granule bin and screen box	5-11
	– Open the cutter house door	5-11
	– Open the hopper	5-12
	– Open the granule bin and screen box and changing the screen	5-13
5.8	Close the screen box, granule bin, cutter house door and hopper	5-15
	– Install the screen box and screen	5-15
	– Install the granule bin	5-16
	– Close the hopper	5-16
	– Close the cutter house door	5-17

## 6. Operation and daily maintenance

6.1	Start and stop	6-2
	– Start	6-2
	– Stop	6-3
6.2	Inspection	6-4
	– Daily inspection	6-4
	– Weekly inspection	6-4
	– Monthly inspection	6-5
	– Inspection every 3 month	6-5
	– Inspection every 6 month or 1000 running hours	6-5
6.3	Stoppage and overloading of granulator	6-7
	– Stoppage in cutter housing	6-7
	– Stoppage in blower	6-8
	– Stoppage in hopper	6-8
	– Stoppage in material conveyance system	6-8

6.4	Cleaning	6-10
	– Re-install after cleaning	6-13
6.5	Fault finding	6-15
	– The granulator does not start	6-15
	– The granulator stops for some unaccountable reason	6-16
	– The cutter house door can not be opened	6-17
	– The hopper can not be opened	6-17
	– Granulator with band conveyor the conveyor does not start	6-18

## 7. Service

7.1	Knife changing	7-2
	– Length, dimensions and strength class on screws	7-3
	– Tightening torque and torque wrench	7-3
	– Check the type of cutter housing	7-3
	– Rotating knives	7-3
	– Fixed knives	7-4
	– To change the knives	7-4
	– Screws and nuts with red marking	7-5
	– Removing of knives	7-5
	Removing of rotating knives	7-5
	Removing of fixed knives	7-6
	– Installing of knives	7-9
	– Pre-setting of knives	7-9
	– Pre-setting	7-10
	– Installing of pre-set knives	7-10
	First install the fixed knives	7-11
	Installing of rotating knives	7-14
	– Check the knife installation	7-16
	– 4 - 8 hours after knife changing	7-16
7.2	Grinding of knives	7-17
	– Cool the knives when you grind them.	7-17
	– Grinding fixture	7-17
	– First grind the relief angle	7-18

-	Then grind the cutting angle on the knife edge	7-18
-	Grinding rotating knives	7-18
-	Grinding of rear fixed knife no. 1, front fixed knife no. 2, the fourth and fifth fixed knife	7-19
-	Grinding the third fixed knife	7-21
7.3	Transmission	7-22
-	Inspection of the drive belts	7-22
-	Checking and adjustment of the drive belt tension	7-23
7.4	Lubrication	7-25
7.5	Cutter lock	7-26

## 8. Spare parts list, Overview

8.1	Cutter housing	8-3
8.2	Cutter 3-blade and 5-blade	8-5
8.3	Knives	8-6
8.4	Transmission 380-420 Volt/50Hz	8-7
8.5	Transmission 60Hz	8-8
8.6	Screen and screen box	8-9
8.7	Granule bin	8-10
8.8	Hopper front	8-11
8.9	Inlet, sound trap, flap	8-12
8.10	Outfeed, blower F25	8-13
8.11	Outfeed, blower F40	8-14
8.12	Body	8-15
8.13	Jack	8-16
8.14	Cutter lock	8-17
8.15	Enclosure	8-18
8.16	Electrical components	8-19
8.17	Security	8-20

8.18	Flywheel	8-21
8.19	Cyclone and dust filter	8-22
8.20	Tools and fixtures	8-23

## 9. Wiring diagram

9.1	Current sensing relay	9-3
	– Connection	9-3
	– Setting	9-3
	Default setting for this granulator	9-4
	– Example	9-5

## 10. Layout

10.1	Layout	10-2
------	--------	------

## 11. Options, Overview

11.1	Knife pre-setting fixture	11-3
11.2	Cutter housing, changing rear side of the cutter housing	11-5
11.3	Friction clutch, cutter belt pulley, flywheel	11-6
11.4	Blower F25 and F40, safety, installation, maintenance	11-7
11.5	Speed monitor	11-9
11.6	Paddle monitor	11-10
	– Setting the paddle monitor sensitivity	11-10
11.7	Band conveyor	11-11
	– Safety, installation, electrical connection, start	11-11
	– Maintenance, fault finding	11-12
	– Spare parts for band conveyor	11-14

## 12. Transport, lift and storage

	– Lift and transport to place of use	12-4
	– Storage	12-5

## 13. Service and maintenance schedule

Machine data .....	13-2
- Installation .....	13-3
- Inspection .....	13-5
Weekly inspection .....	13-5
Monthly inspection .....	13-8
Inspection every 3 month .....	13-10
Inspection every 6 month or 1000 running hours .....	13-12
- Knife changing .....	13-14
- Malfunctions .....	13-15
- Notes .....	13-16

## A Appendix

Service/Warranty Information .....	A-1
------------------------------------	-----



# Introduction

---

Introduction . . . . . 1-2

# Introduction

This manual is for CONAIR's CW granulators. Models 1824, 1836 and 1848.

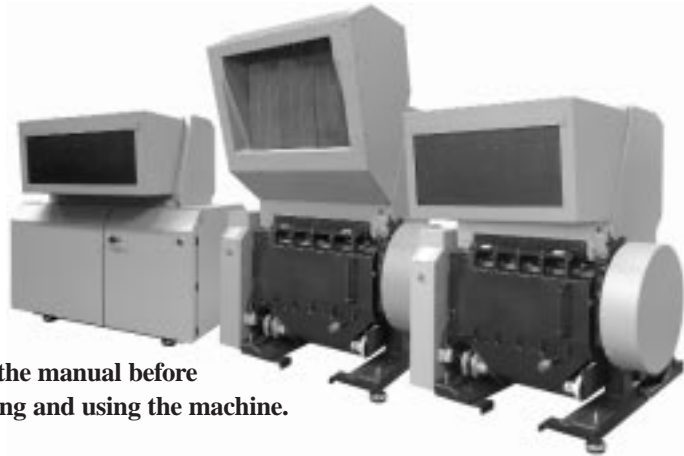

**Study the manual before installing and using the machine.**

The CW Granulator granulator is as standard equipped with a 3-blade cutter but can as an option be equipped with a 5-blade cutter.



**Take care when the knives are exposed, they are sharp and could cause personal injury.**

This CONAIR granulator is designed to granulate waste resulting from injection molding, blow molding or extrusion. The plastic waste must be free from contamination such as metal, poisonous, flammable or explosive items or any other substances that in any way are unhealthy.

Permission in writing is required from the supplier of the machine before using it to process any other products or material. The supplier of the machine is always to be consulted in the event of any doubt.

The granulator is not intended for the processing of wood, household or garden refuse, medicaments or substances detrimental to health unless express written permission is obtained from the supplier of the machine.

The size and performance of the granulator is designed and adapted to suit the type of plastic waste specified by the customer on ordering.

Approval must be obtained from the Conair head office for granulating other products and materials for the warranty conditions to apply.

The granulators are designed so that maintenance and cleaning can be done quickly and easily, both routine maintenance and changing of materials.

All service is to be performed by trained service personnel.

This manual contains instructions for installation, operation and service.

Section 5 contains instructions for service personnel concerning installation.

Section 7 contains instructions for service personnel.

Section 11 contains information concerning optional equipment for the machine.

Section 13 contains installation and service diagrams for the machine. The entire machine guarantee and Conair's product responsibility will become invalid if the installation and service diagram is not filled in and signed.

The remaining sections contain instructions for the operator.

In the delivery of the CW Granulator granulator is included:

One instruction manual in English.

One tool bag containing:

- one 22 mm hexagon socket wrench to open the cutter house door.
- two presetting fixtures, compact models, to pre-set the knives.
- one feeler gauge 0.20 mm.
- touch-up paint.

Any modification or conversion of the granulator is subject to written approval from Conair's head office, with the object of preventing injury or damage and to maintain the guarantee and product liability.

Please contact the local Conair agent or the Conair head office in the event of any questions.

Head Office:

Conair

One Conair Drive

Pittsburgh, PA 15202

Phone. 412-312-6000

Fax. 412-312-6227

Homepage: [www.conairnet.com](http://www.conairnet.com)

E-mail: [info@conairgroup.com](mailto:info@conairgroup.com)

We reserve the right to make continuous design and material changes  
and to amend specifications without prior notice.



# Technical Specification

---

Dimensions . . . . .	2-2
Types of cutter housings . . . . .	2-2
Data . . . . .	2-3
Sound level . . . . .	2-4

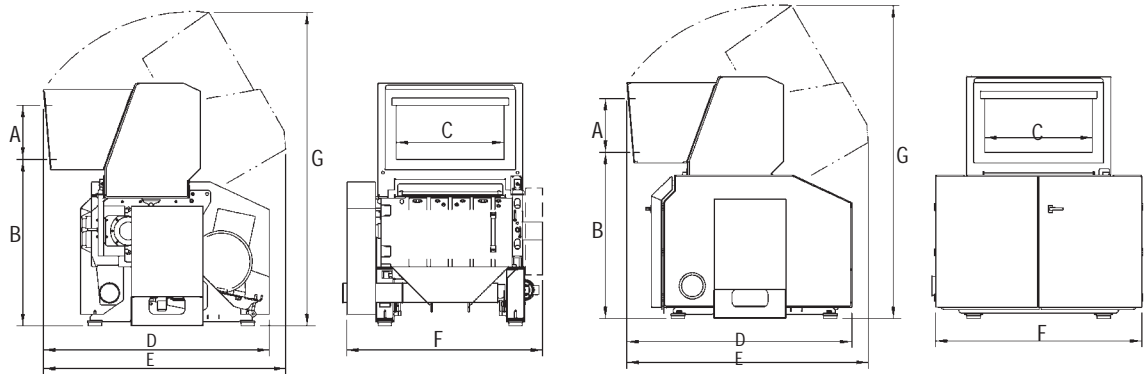

Machine				With Soundproofing		
	1824	1836	1848	1824	1836	1848
A	1400	1400	1400	1400	1400	1400
B	450	450	450	450	450	450
C	600	900	1200	600	900	1200
D	1900	1900	1900	1900	1900	1900
E	2040	2040	2040	2040	2040	2040
F	1340	1640	1940	1440	1740	2040
G	2640	2640	2640	2640	2640	2640

See also Section 10. Layout

## Types of Cutter Housings

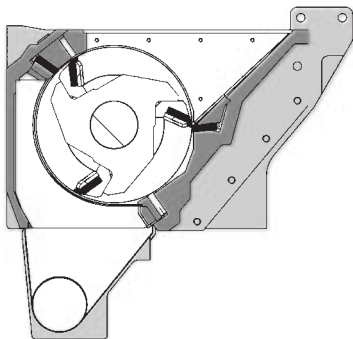

Cutter with 3 rotating knives.  
The basic version of cutter house.  
The cutter housing is fitted with 2 fixed counter knives.  
Fixed counter knife 1 and 2.  
Space available for two additional fixed counter knives to increase capacity.  
Fixed counter knife 4 and 5.

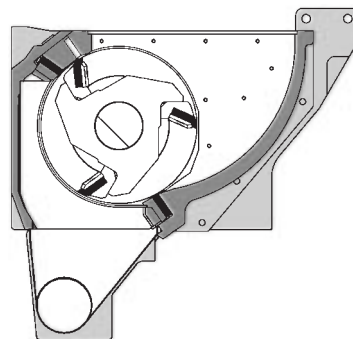

Cutter with 3 rotating knives.  
The cutter house intended for bulky items.  
The cutter housing is fitted with 2 fixed counter knives.  
Fixed counter knife 2 and 5.  
Space available for one additional fixed counter knife to increase capacity.  
Fixed counter knife 4.

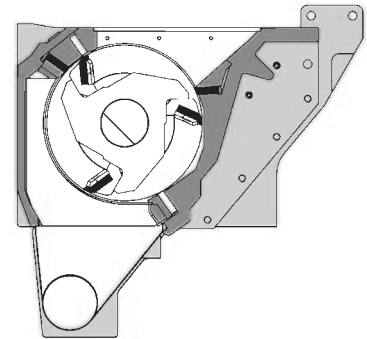

Cutter with 3 rotating knives.  
The cutter house intended for precutting function.  
The cutter housing is fitted with 2 fixed counter knives.  
Fixed counter knife 2 and 3.  
Space available for two additional fixed counter knives to increase capacity.  
Fixed counter knife 4 and 5.

## Data

Motor power	1824 standard	22.0 kW
option	18.5; 30.0; 37.0; 45.0; 55.0 kW	
Motor power	1836 standard	30.0 kW
option	18.5; 22.0; 37.0; 45.0; 55.0 kW	
Motor power	1848 standard	37.0 kW
option	18.5; 22.0; 30.0; 45.0; 55.0 kW	
<b>V-belts</b>	50 Hz motor:	18.5; 22.0 kW ..... 3 pcs. 30.0; 37.0 kW ..... 4 pcs. 45.0; 55.0 kW ..... 6 pcs.
	60 Hz motor:	18.5; 22.0 kW ..... 3 pcs. 30.0; 37.0 kW ..... 5 pcs. 45.0; 55.0 kW ..... 6 pcs.
<b>Cutter speed</b>		525 rpm.
<b>Capacity</b>	1824	< 600 kg/h.
	1836	< 900 kg/h.
	1848	< 1200 kg/h.
<b>Blower type</b>	F-25 (1824 and 1836 only)	2.20 kW
	F-40	4.00 kW
<b>Cutter size</b> (diameter x width)	1824	450 x 600 mm.
	1836	450 x 900 mm.
	1848	450 x 1200 mm.
<b>Rotating knives</b>		
		3-blade cutter      5-blade cutter
	1824	2 x 3 pcs.      2 x 5 pcs.
	1836	2 x 3 pcs.      2 x 5 pcs.
	1848	2 x 3 pcs.      2 x 5 pcs.
<b>Fixed knives</b>		2 pcs. (2 x 2 pcs.)
	– Fixed knife no. 1	1 pc. (2 pcs.)
	– Fixed knife no. 2	1 pc. (2 pcs.)
	– Fixed knife no. 3 (option)	1 pc. (2 pcs.)
	– Fixed knife no. 4 (option)	1 pc. (2 pcs.)
	– Fixed knife no. 5 (option)	1 pc. (2 pcs.)

## Data (continued)

<b>Screen Ø</b>	standard	8 mm.
	option.	5; 6; 10; 12; 17; 25 mm.
<b>Weight</b>	1824	with extraction fan approx. 2,350 kg.
	1836	with extraction fan approx. 2,850 kg.
	1848	with extraction fan approx. 3,550 kg.
	1824	with soundproofing and extraction fan approx. 2,500 kg.
	1836	approx. 3,000 kg.
	1848	approx. 3,700 kg.

## Sound level

**Sound level** ..... range about 80 - 85 dBA

The equivalent acoustic pressure level of the granulator in operation (granulation of plastics) is within the range stated above. The acoustic pressure level is measured 1 meter from the granulator and 1.6 meters above the floor.

The acoustic pressure level may vary and is dependent on the type of granulated plastics, the shape of granulated items, granulator feed equipment and the general surroundings (premises).

Ear protection is recommended to avoid damage to hearing.

# Functional Description

---

3.1 General . . . . .	3-2
3.2 Safety system . . . . .	3-5
– Main switch . . . . .	3-5
– Emergency stop . . . . .	3-6
– Cutter lock . . . . .	3-6
– Safety switches . . . . .	3-6
– Standstill monitor . . . . .	3-7
– Important parts which belongs to the granulator safety system . . . . .	3-7
– Before the granulator can be started	3-7

## 3.1 General

The granulator is designed to granulate injection molded, blow molded or extruded plastics waste.

The plastic waste must be free from contamination such as metal, poisonous, flammable, explosive or any other substances that in any way are unhealthy.

The granulator is controlled by start/stop controls on a control panel.

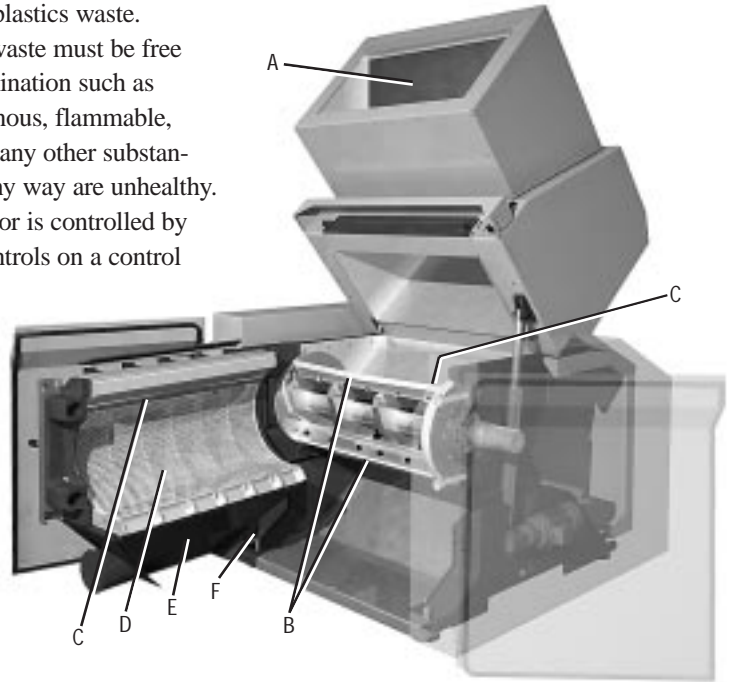

The plastic waste is fed in to the hopper “A” and falls down into the cutter housing, where rotating knives “B” cut the plastics against fixed knives “C” to granulate.

A perforated screen “D” determines the size of the granulate.

The screen is located in the front and lower section of the cutter housing and can easily be changed to give the desired granulate size.

The granulate passes the screen and falls down through the granule bin “E” towards the outlet pipe “F” for further transport.

The granulator is optimized prior to order and adapted to the customer requirements, with the aid of three cutter-house widths: 18-24, 18-36 and 18-48. and three types of cutter houses:

- The basic version of cutter house.
- Cutter house intended for bulky items.
- Cutter house intended for precutting.

The type of cutter housing can subsequently be altered and adapted, if the need arises, by changing the rear part of the cutter housing. Please contact Conair’s head office with regard to altering the type of cutter housing.

A cutter with 5 rotating knives is available as an option to further enhance the wide range of use for the CW granulator.

## Types of cutter housings

### The basic version of cutter house

Cutter with 3 rotating knives. The basic version of cutter house.

The cutter housing is equipped with 2 fixed counter knives. Fixed counter knife no. 1 and no. 2.

Space is available for two additional fixed counter knives which gives a higher capacity. Fixed counter knife no. 4 and no. 5.

### The cutter house intended for bulky items

Cutter with 3 rotating knives. The cutter house intended for bulky items.

The cutter housing is equipped with 2 fixed counter knives. Fixed counter knife no. 2 and no. 5.

Space is available for one additional fixed counter knife which gives a higher capacity. Fixed counter knife no. 4.

### The cutter house intended for precutting

Cutter with 3 rotating knives. The cutter house intended for precutting function.

The cutter housing is equipped with 2 fixed counter knives. Fixed counter knife no. 2 and no. 3.

Space is available for two additional fixed counter knives which gives a higher capacity. Fixed counter knife no. 4 and no. 5.

## Extraction blower

Granulators equipped with an optional extraction blower eject the granulate into a cyclone, for air separation.

The granulate are then ready for reuse in the production machine, or for transportation to a container for later use.

## Simple cleaning



The CW granulator facilitates access for simple and fast cleaning.

The cutter housing is opened via a door and an electric jack opens the hopper.

Access to all the places that need cleaning when changing color or type of plastics is quick and easy.

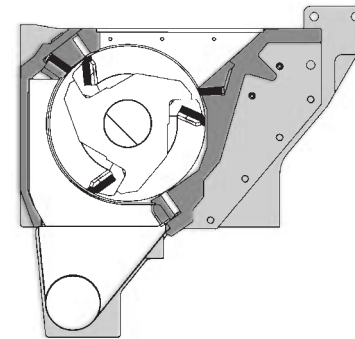
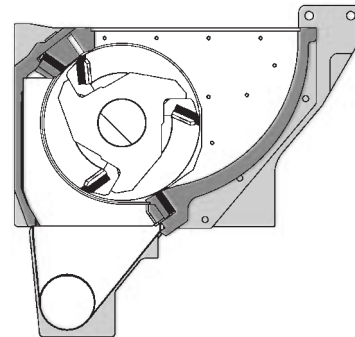
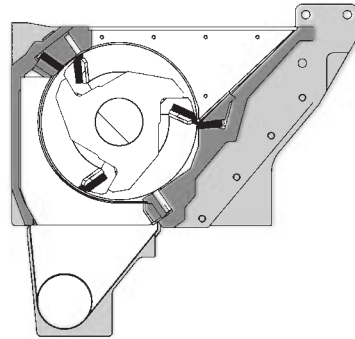

### **Belt conveyor**

Granulator models may be equipped with an optional belt conveyor. The conveyor can be equipped with a metal detector.

### **Grinding the knives**

All knives in the granulator can be re-ground. Sharpening is best done using a special grinding fixture. The fixture is an optional feature and is not included in delivery of the machine.



## 3.2 Safety system

The granulator has a safety system to prevent access to dangerous components during operation.

The granulator has knives which rotate at high speed and with great force. The granulator is therefore equipped with main switch, emergency stop, cutter lock safety switches and standstill monitor to avoid personal injury.

The safety system must not be changed or modified under any circumstances. If the safety system of the granulator is changed or modified, the machine can be dangerous to use, presenting a serious risk of personal injury.

All maintenance and service to the safety system of the granulator must be carried out by personnel with the necessary knowledge.

If the safety system of the granulator is modified in any way, Conair's responsibility under the Machinery Directive ceases to apply.

Only spare parts from Conair may be used when replacing safety components.

### Safety instructions

Instructions and safety measures in this manual are to be followed to avoid personal injury and damage to the machine.

### Main switch

The main switch is located on the electric cabinet.

The main switch breaks all three poles of the incoming 3-phase power.



Position 1 is "On"



Position 0 is "Off"

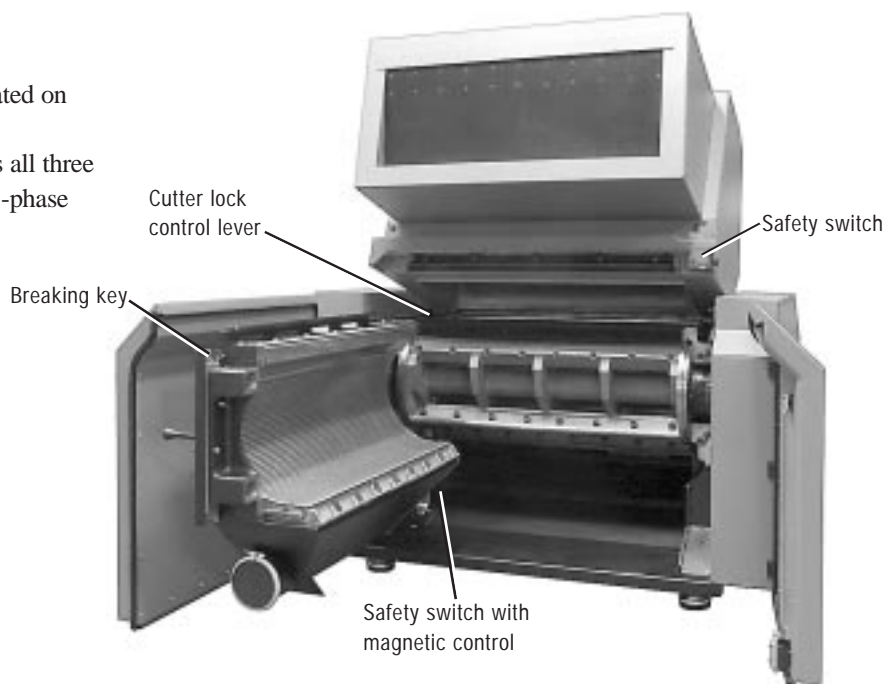

## Emergency stop

One emergency stop is located on the control panel. The granulator can be equipped with extra emergency stops. The emergency stop is activated by pressing the button. Resetting is effected by turning the button in the direction of the arrow (counterclockwise).



## Cutter lock

The CW granulator is equipped with a cutter lock. The cutter lock is activated automatically when the hopper opens. The cutter lock control lever resets automatically when the hopper closes. A control lever is provided to release the cutter lock manually for service and maintenance purposes.

## Safety switches

The CW Granulator granulator models have safety switches of the position switch type:

The safety switches cut the control current in the granulator, so that the granulator stops if the cutter house door, hopper or granule bin changes position.

This granulator has 2 safety switches:

- 1 Safety switch with a breaking key at the hopper, located between the hopper and the cutter housing. The safety switch is integrated with the lock to the cutter house door. The safety switch senses that the cutter house door is closed and that the hopper seals housing. If the hopper or the cutter house door changes position, the granulator stops.
- 1 Safety switch with magnetic control to the granule bin. The safety switch to the granule bin sense when the granule bin is installed. The granulator cannot be started unless the granule bin is installed.



The granulator can be equipped with additional safety features depending on optional equipments.

Accordingly, check the electric circuit diagram for your granulator, to see, how many safety switches just your granulator is equipped with.



## Standstill monitor

The CW granulator has a standstill monitor, which senses inductively when the cutter has stopped. The standstill monitor locks the breaking key to the locking device on the door to the cutter house, so long time as the cutter is in motion. The locking device to the cutter house door can not be opened if the cutter is in motion.

## Important parts which belongs to the granulator safety system

- The granulator inlet part should always be installed during operation.
- The granulator must never be used without the hopper inlet part.
- The granule bin must always be properly installed.
- The cutter house door must always be properly closed.

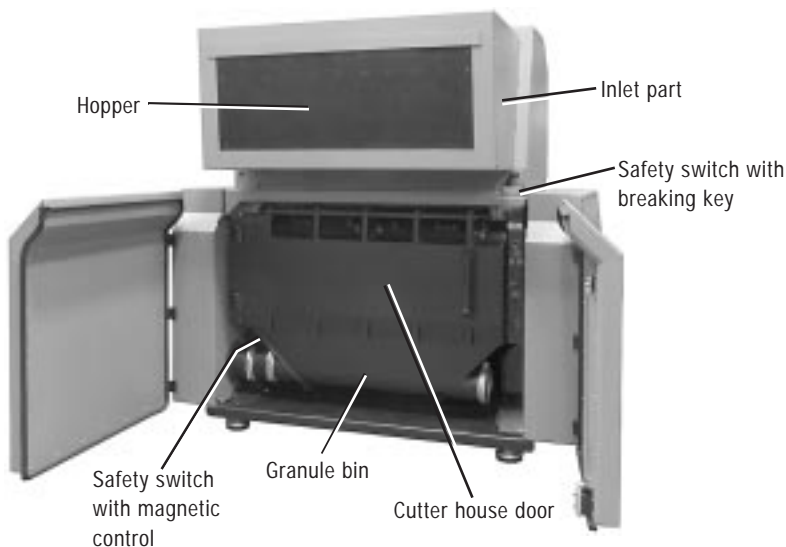

## Before the granulator can be started

- The hopper must be closed.  
The safety switch senses that the hopper seals tightly against the cutter housing.
- The granule bin must be properly installed.
- The cutter house door must always be properly closed.  
The safety switch checks that the cutter house door is closed.
- The granulator safety relay must be reset.



# Security

---

4.1	Safety system	4-2
	– Markings on the granulator and optional equipment that stipulate caution	4-2
	– Parts of the safety system	4-3
	– Important parts belonging to the safety system of the granulator	4-3
4.2	Functional description of parts of the safety system	4-4
	– Emergency stop	4-4
	– Cutter lock	4-4
	– Safety switches	4-4
	– Standstill monitor	4-5
4.3	Safety instructions	4-6
	– Safety instructions and safety measures during operation	4-6
	– Safety instructions and safety measures concerning the electrical system	4-7
	– Safety instructions and safety measures with regard to cleaning, maintenance and service	4-7
4.4	Personal safety equipment	4-10
	– Ear protection	4-10
	– Protective gloves	4-10
	– Protective goggles	4-10
4.5	Safety instructions and caution when changing knives	4-11
	– Length, dimensions and strength class on screws	4-12
	– Tightening torque and torque wrench	4-12
	– Tips for installation of knives	4-12



**Read through the whole instruction manual before installing and using the machine.**

All service must be done by trained and competent personnel.

Any modification or conversion of the granulator is subject to approval by Conair, with the object of preventing injury or damage and to maintain the guarantee and product responsibility.

Instructions for lifting and transporting the granulator are in section 12 of this instruction manual.

## 4.1 Safety system

The granulator has knives which rotate with great force and at high speed. The granulator is therefore equipped with a safety system to prevent contact with dangerous parts during operation in order to avoid personal injury.

### Markings on the granulator and optional equipment that stipulate caution

Parts of the granulator and its optional equipment that imply danger, the need of caution or particular attention are marked accordingly.



**WARNING! Dangerous voltage!**

This sign is on the door to the electrical cabinet and connection boxes.



**WARNING! Cutting or pinch risk!**

This sign is placed where there is a risk of being cut or pinched.



**WARNING! Be careful!**

This sign is located by all danger areas, where care and extra attention is required.



**WARNING! Pinch risk!**

This sign is placed where there is a risk of being pinched, extra attention is required.

The instruction manual contains the same marking where particular attention is emphasized.

## Parts of the safety system

The parts of the safety system shall prevent contact with dangerous items during operation in order to avoid personal injury.

### **The safety system includes:**

- Emergency stop
- Cutter lock – mechanical brake
- Safety switches – position switches
- Standstill monitor– with inductive sensing

The granulator safety system must not be changed or modified under any circumstances.

If the safety system is modified in any way, Conair's responsibility under the Machinery Directive ceases to apply.

The function of the safety system is described in section 3 of the instruction manual.

Only spare parts from Conair must be used to replace components of the safety system.

## Important parts belonging to the safety system of the granulator

- The granulator inlet part should always be installed during operation.
- The granulator shall never be used without the inlet part.
- The granule bin should always before start be properly installed.
- The cutter house door must always be properly closed.

## 4.2 Functional description of parts of the safety system

### Emergency stop

Red round push-button on yellow base, is on the control panel.

The granulator can be fitted with additional emergency stops, depending on the function and optional equipment.

The emergency stop is activated by pressing the button.

Resetting is effected by turning the button in the direction of the arrow (counterclockwise).

Resetting of a emergency stop button with key lock is effected by:

- Open (unlock) the emergency stop button lock using a key, then turn the button in the direction of the arrow (counterclockwise).

### Cutter lock

The cutter lock is activated automatically when the hopper opens and the cutter and knives in the granulator are accessible.

The cutter lock consists of a mechanical brake, which keep the cutter belt-pulley still with a rubber damper, when the hopper is opened.

A control lever is provided to release the cutter lock manually for service and maintenance purposes.

The cutter lock control lever resets automatically when the hopper closes.

### Safety switches

#### **Safety switch of the position switch type**

Safety switch of position switch type with magnet, at the granule bin, cut the control current in the granulator, so that the granulator stops if a safe position change position or is opened.

The safety switch of position switch type with breaking key, cut the control current in the granulator, so that the granulator stops if a safe position change position or is opened.

The safety switch of position switch type located at a roll feeder or a roll package only stops the roll feeder.

## Standstill monitor

The standstill monitor checks inductively that the cutter has stopped.

The standstill monitor influences the safety switch between the hopper and the cutter housing. The safety switch holds the breaking key to the locking device on the cutter house door locked, so long time as the standstill monitor senses that the granulator cutter is in motion.

The lock to the cutter house door cannot be opened, while the time the cutter is in motion.

An indication lamp in the knob "Hopper operate I" on electrical cabinet and a green diode lamp on the safety switch lights, when the standstill monitor senses that the granulator cutter has stopped. The lock in the safety switch opens simultaneously, the lock which locks the breaking key to the locking device on the cutter house door.

## 4.3 Safety instructions

The following safety measures shall always be followed when handling the granulator:

### Safety instructions and safety measures during operation



- At least one emergency stop shall always be within reach of the operator.
- It shall not be possible to start the granulator until the hopper and the door to the cutter house are properly closed.
- The granulator must not be used without the granule bin. The granule bin is part of the safety devices on the granulator. The granule bin must always be installed during operation.



- Flammable material or material which is contaminated by flammable substances/liquids may not be processed in the granulator. Serious risk of fire or explosion.



- Never remove the protective grids or pipes connected to the outfeed, granule bin or blower.
- Never remove the flaps from hopper.

### Blowers



- Conair's blowers are intended for dust- and material conveying. The temperature of the conveyed material must never exceed 80°C.
- It is not permitted to use the blowers in humid environments, unprotected outdoors, in explosive atmospheres or in surroundings where the temperature exceeds 40°C or goes below -20°C.



- Conair's blowers have very high suction power. **WARNING!** Objects and clothing can easily be sucked in to the blower inlet and cause personal injury.



- The stream of air from the discharge opening is very powerful. **WARNING!** Granulate and objects which have been sucked in to the blower, will be thrown out at very high speed and can cause personal injury. Never put the hand directly in front of the blower discharge opening.

### Granulator with band conveyor



- Observe care so that conveyor band with dogs do not grip clothings, or arms and feet.
- If the belt conveyor is used for hot plastic waste: Ensure that the hot plastic waste is deposited on the middle of the band, ie, uneven heating of the band could cause it to run askew.

### Granulator with roll feeder



- There must always be a gap between the feed rolls. There must never be metallic contact between the feed rolls.



- There must always be a gap between the scrapers and the feed rolls.  
The scrapers must never have metallic contact with the feed rolls.

**Safety instructions and safety measures concerning the electrical system**



- Electrical installation must only be done by a competent electrician!
- The electrical cabinet of the machine contains hazardous high voltage.
- The electrical cabinet door must never be opened when the granulator is in operation.
- Immediately after the granulator hopper is opened during service and maintenance, break the power supply with the main switch on the electrical cabinet. Then lock the knob to the main switch.



- Never insert fingers, hands or arms into openings of the granulator, if not the knob to the main switch is in “Off” (0) position and locked.
- The key for the electrical cabinet is a safety component.  
The key must be kept by the person who is responsible for granulator safety, service and maintenance.
- Never change or modify the basic electrical settings of the granulator, without first obtaining permission from Conair.  
If the granulator settings are changed, the machine can be seriously damaged.  
All Warranties and Conair’s Product Liability will be void, if the basic settings of the granulator are changed.
- All electrical maintenance and service work must be done by trained and competent personnel.

**Safety instructions and safety measures with regard to cleaning, maintenance and service**



- All service must be carried out by trained personnel in order to avoid personal injury or damage to the machine.



- Never leave the granulator without supervision while the cutter lock is released. Danger of personal injury and damage to the machine.
- **WARNING!** Granulate and plastic rests on the floor can cause risk of slipping!  
Risk of slipping depending of granulate and plastic rests, is especially hazardous when the cutter house door is open, during cleaning, maintenance and service.



- Always use protective goggles and protective gloves during cleaning, maintenance and service.



- **NOTE:** When the cutter house door and the hopper have been opened for service or maintenance, it is recommended that the cutter in the granulator is covered by using a carpet.  
This to avoid that any person can be injured in contact with the cutter.



- Take care when the knives are accessible, they are sharp and could cause personal injury.
- Never try to stop a cutter by hand when it is moving, even when the moving is slowly.

Cutter, cutter shaft and cutter belt pulley, and flywheel if any, is a heavy unit. The energy of a cutter in motion is considerable.

The danger of injury to fingers and hands is very great.

- **NOTE:** Never use help when closing the door to the cutter house. Close the door to the cutter house alone.

The cutter house door is heavy, and the risk of injuring fingers or hands increases when two or more persons works, to close the cutter house door. Be careful!

- The door to the cutter house must be opened fully, otherwise it will not be possible to open or close the hopper.



- There is a danger of being crushed when opening or closing the hopper, door to the cutter house, screen box and granule bin, be careful!
- **NOTE:** Never use help when cleaning the granulator. Carry out the cleaning alone and observe caution!

The risk of injuring fingers or hands increase if two or more persons are used to clean the granulator.



- **NOTE:** The flap package in the hopper to the is heavy with an extraction fan and sound proofing. There is danger of personal injury or damage to the machine if the flap package is dropped.



- The key for the electrical cabinet must be kept by the person who is responsible for granulator safety, service and maintenance. The key is a safety component.

### Knives



- The machine contains rotating knives. They are sharp and can cause personal damage, even when they are not rotating.
- At all work on the fixed knives placed in the cutter house door, it is recommended that the cutter in the granulator is covered by using a carpet.

This to avoid that any person can be injured in contact with the cutter.

- Be careful when you handle knives, they are sharp and can cause personal injury.



- If the cutter must be turned manually, – do this with very great care!
- Conair knives are made from hardened steel.  
**NOTE:** Hardened steel knives are brittle and can crack if they are dropped or are handled carelessly.
- It requires skill & experience to grind knives.  
Please let a skilled, experienced craftsman grind the knives.

### Transmission



- There is a pinch risk at inspection and adjustment of the drive belts.  
WARNING! Pinch risk between pulleys and drive-belts.

### Granulator with band conveyor



- During maintenance of band conveyor, pull out the plug on the electrical cabinet!

### Granulator with roll feeder



- There is a pinch risk during opening or closing of the roll feeder and roll package, be careful.



- When the roll package have been folded up for service and maintenance, cover the hopper inlet opening so that no screws and tools can fall down into the cutter housing.

## 4.4 Personal safety equipment

### Ear protection



Conair recommends that ear protection is used during all granulation of plastics.

Granulation of hard plastic, big plastic details, or plastic lumps can cause high and dangerous sound.

Observe also that low sound levels during a long time is dangerous.

Reduce the risk of damage to hearing. Use ear protection or earplugs.

Avoid standing in front of the granulator hopper inlet opening.

**Signs of overload after granulating plastic parts and lumps of plastic are:**

- Ringing sound, tones or ear pain.
- Difficulty in hearing people speaking when the granulator has stopped.
- A sense of water in the ears.

### Protective gloves



Be careful at all handling of knives, they are sharp and can cause personal injury.

Use protective gloves when changing knives, so as not to injury fingers or hands.

Always use protective gloves at cleaning, maintenance and service!

### Protective goggles



Conair recommends that safety goggles are used during all granulation of plastics.

Always use protective goggles at cleaning, maintenance and service!

## 4.5 Safety instructions and caution when changing knives

The following safety measures and caution, shall be observed when changing knives:



**NOTE:** Make sure that there never are any granulate or plastic rests on the floor during changing of knives.

**WARNING! Granulate and plastic rests on the floor can cause risk of slipping!**

**If anyone slips or falls during changing of knives, or handling of knives, it can cause serious personal injury.**



**NOTE:** The granulator is equipped with a cutter lock!

**NOTE:** Before starting to change the knives! Check that the cutter lock of the granulator brakes the cutter, immediately after the hopper is opened!

**WARNING!**

**NOTE:** When you release the cutter lock, the cutter auto-rotates, for instance at removing or installing of rotating knives.

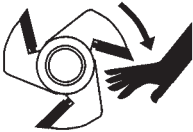

**The cutter auto-rotates when the center of gravity becomes unstable when removing or installing knives.**

**So therefore be careful when changing knives, so as not to injure fingers or hands.**



**OBSERVE! Never resort to help** when removing or installing rotating knives. Always carry out knife changing alone, so as to minimize the risk of injury to fingers or hands.

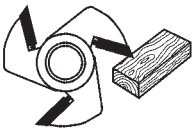

**The cutter lock brakes the cutter belt pulley, but for safety reasons, when screws on knives are removed or installed with tightening torque, always secure the cutter to the cutter housing using a strong block of wood, to avoid that the brake can glide.**



**Always use protective gloves when changing knives!**

Each time the set of knives is changed, the screws which hold the knives must be replaced by new ones.

Every second time re-sharpened knives are installed, the screws which hold the knives must be replaced by new ones.

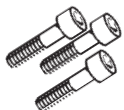



When installing rotating knives, always install all the rotating knives on the cutter, so that the cutter will be balanced.

### Length, dimension and strength class on screws

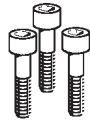

All screws which retain the knives are of high strength class.

Only screws supplied by Conair may be used for installing knives.

Conair's responsibility and guarantee become invalid unless genuine

Conair screws of the right length, dimension and strength class are used.

### Tightening torque and torque wrench



It is very important that the knives are torqued to correct tightening torque.

All screws must be tightened using a torque wrench to the specified tightening torque which is stated in the machine instruction manual.

If a torque wrench is not used or if screws are not tightened to the specified tightening torque which is stated in the machine instruction manual, Conair's responsibility and guarantee become invalid.

### Tips for installation of knives:

Mark each knife, with a felt-tip pen when each task is carried out:



= The knife clearance is correctly set.



= The knife screws are torqued to the correct torque.



= The knife clearance has been re-checked and is correct.

### Tips for installation of pre-set knives:

Mark each knife, with a felt-tip pen when each task is carried out:



= The knife clearance is correctly set in the pre-setting fixture.



= The knife screws are torqued to the correct torque.



= The knife clearance has been re-checked and is correct.

# Maintenance

---

- 5.1 Place of use ..... 5-2
  - Floor, foundation, place of use ..... 5-2
  - Safety distance when opening the hopper ..... 5-2
- 5.2 Install the hopper ..... 5-3
- 5.3 Install the front inlet part ..... 5-5
- 5.4 Electrical connection ..... 5-6
  - Location of the electrical cabinet ..... 5-6
  - Check the direction of rotation of the granulator motor .... 5-6
  - Check the direction of rotation of the blower motor ..... 5-7
  - Check the direction of rotation of the  
optional equipments ..... 5-7
  - If any direction of rotation is wrong ..... 5-7
- 5.5 Installation ..... 5-8
  - Adjust the granulator stand ..... 5-8
- 5.6 Actions before the first start ..... 5-9
  - Clean the granulator from anticorrosive agent ..... 5-9
  - Check before the first start ..... 5-9
  - 5.6.1 Two hours after first start ..... 5-9
  - 5.6.2 20 - 30 hours after first start ..... 5-10
- 5.7 Open the cutter house door, hopper, granule bin and  
screen box ..... 5-11
  - Open the cutter house door ..... 5-11
  - Open the hopper ..... 5-12
  - Open the granule bin and screen box and changing  
the screen ..... 5-13
- 5.8 Close the screen box, granule bin, cutter house  
door and hopper ..... 5-15
  - Install the screen box and screen ..... 5-15
  - Install the granule bin ..... 5-16
  - Close the hopper ..... 5-16
  - Close the cutter house door ..... 5-17

# 5. Installation



Read through the whole section 5 before installing the machine. All instructions must be followed in the order shown to avoid damage.

Lift and transport



Read and follow the instructions in section 12 for lifting and transportation of the granulator.



Depending on the mode of transport and delivery the granulator can be delivered with the hopper or hopper inlet part unmounted.

## 5.1 Place of use

A free space is needed around the granulator to facilitate cleaning, service and maintenance.

### Floor, foundation, place of use

Check and make sure that the floor on the place of use is horizontally and is sufficiently strong for the granulator in operation. If the floor is uneven it should be levelled before installation. Safety distance when opening the hopper

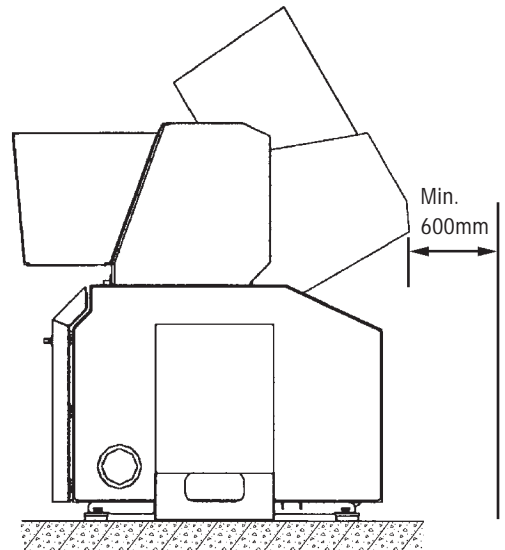

**NOTE:** When opening the granulator hopper a safety zone of at least 600 mm must be kept clear behind the granulator hopper, when the hopper is opened. Check the layout of the granulator in section 10 to see how much space your granulator requires.

## 5.2 Install the hopper

Depending of the way of transport and delivery, the granulator can be delivered with the hopper and the front inlet part to the hopper uninstalled.

When installing the hopper to the granulator, the jack must be able to operate. The jack can not operated before the granulator is connected to the mains.

**1** Noise encapsulated machine, open the doors.

**2** Open the cutter house door,  
*see section 5.7*

**3** Fit two lifting eyes and lift the  
by using a lifting strap.

**4** Lower carefully down and fit the hopper  
against the cutter housing.

**5** Fasten the hopper against the  
rear hinge list, (screws M12,  
tightening torque 220 Nm).

**6** Connect the granulator to  
the mains and turn the main  
switch to position "1" On.

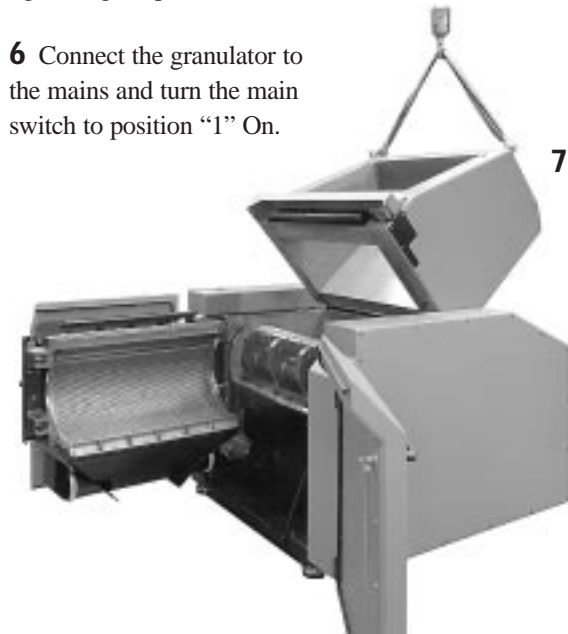

**7** Fold the hopper backwards  
and fit the upper bracket to  
jack against hopper.

(continued)

## 5.2 Install the hopper (continued)

- 8 Check so that no emergency stop is activated.
- 9 Check on rear side of the hopper, in which position of the bracket the hinge list is installed.  
When the hinge list is installed in the front holes of the bracket (as shown in the illustration) . . . .

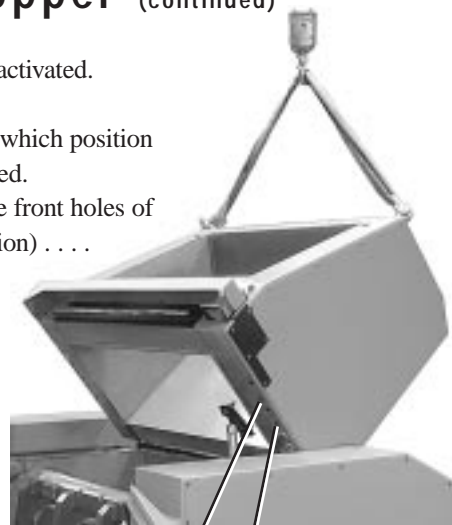
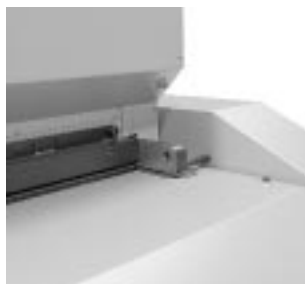

Screw hole no. 2 and 4

- the upper bracket to the jack should be installed in the screw holes 2 and 4.

The jack lifting rod should be vertical after installing.

- 10 Operate the jack so that the screws easily fits into correct screw holes.
- 11 Fasten the screws (M16) to the upper bracket with a tightening torque of 220 Nm.



- 12 Close the hopper.
- 13 Remove the lifting strap and the lifting eyes.

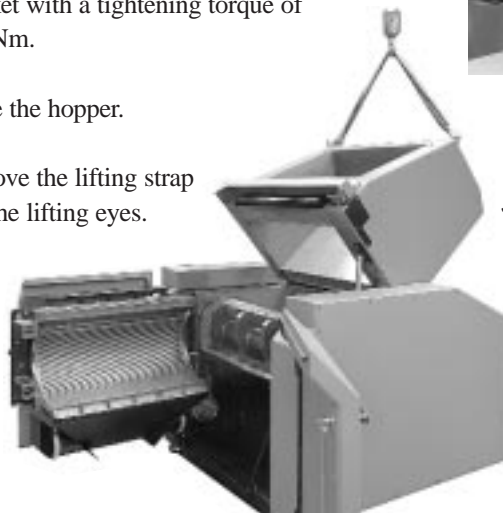

- 14 Call for an qualified electrician to connect the safety switch at hopper.

## 5.3 Install the front inlet part

The hopper can because of space be delivered with the front inlet part uninstalled. The front inlet part can be installed as per following instructions:

- 1 Fit two lifting eyes on top of the front inlet part.
- 2 Fit a lifting strap and then lift the front inlet part.
- 3 Install the flap package.
- 4 Lift carefully the front inlet part to the hopper. Hook in the front inlet part into the hopper. Make sure that the lower guide plate fits into the hopper opening.

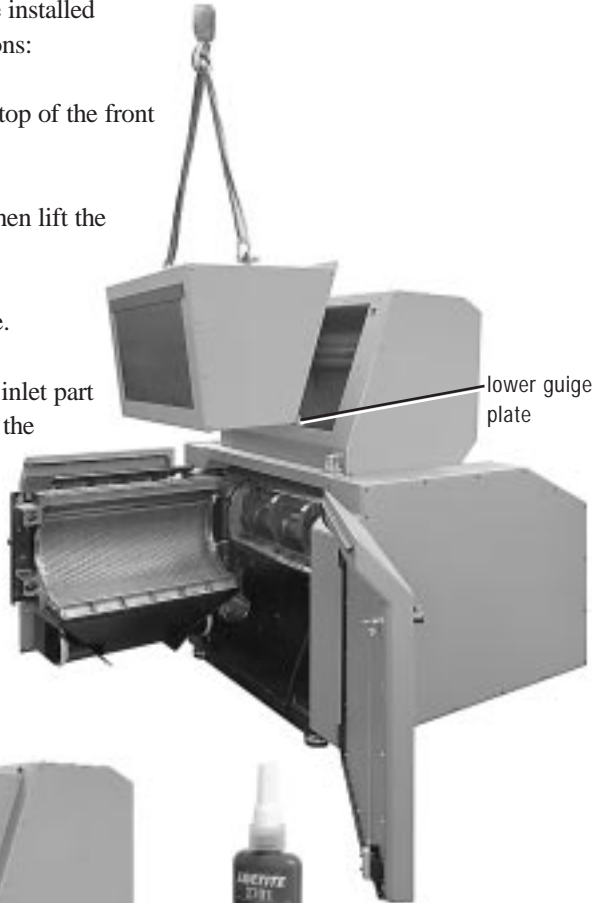

- 5 Fasten the front inlet part by screws in the upper list. Use thread locking and fasten the screws M10 with a tightening torque of 45 Nm.

## 5.4 Electrical connection

To install the granulator the granulator hopper must be opened. The hopper cannot be operated until the granulator is electrically connected.

Connect the granulator to the main power supply. The rated connecting voltage (Volt) and size of fuse (Am) for the machine is stated in the electrical circuit diagram.



**NOTE:** The granulator may only be connected to the main supply by an authorized electrician.

The granulator is connected for a right-hand rotating field on delivery.

Check the phase sequence of the power supply using a phase-sequence indicator and connect the granulator with a connector to the mains power supply.

### Location of the electrical cabinet

The electrical cabinet, with main switch, start panel and emergency stop, must be positioned so that the emergency stop on the start panel is always within reach of the operator during operation and feeding of granulation goods.

If the operator cannot reach the emergency stop knob on the start panel, during operation of the granulator. The granulator must be fitted with at least one additional emergency stop by the responsible electrician as part of the initial installation. At least one emergency stop knob shall always be within reach of the operator in the working range of the granulator, including optional equipment for the granulator such as belt conveyor, shredder, dust filter, etc.



**NOTE:** At least one emergency stop shall always be within reach of the operator.

### Check the direction of rotation of the granulator motor:

Ensure that the granulator stands horizontally and steady.



**IMPORTANT!** Check so that all machine shoes take up load.

- Undo and remove the side plate on left side of the granulator.
- Noise encapsulated machine open the doors.
- Ensure that the cutter house door and the hopper are properly closed.
- Noise encapsulated machine close the doors.



## 5.4 Electrical connection (continued)

- Set the main power switch to position “1” On.
- Ensure that the emergency stop is not activated.
- Start the granulator, press the “Start”-button and stop immediately, press the “Stop” -button.
- Before the motor stops, check the direction of rotation of the granulator motor in relation to the arrow on cutter-belt pulley.



**WARNING.** There is danger of being crushed when checking the direction of rotation of the drive belts.

**WARNING.** Danger of being crushed between belt pulleys and drive belts.

### Check the direction of rotation of the blower motor

- Ensure that the direction of rotation of the blower corresponds to the arrow on the blower casing.



**TIP:** Start and immediately stop the motor.

Before the blower motor stops, – carefully insert the end of a cable tie at the rear through the ventilation opening of the motor and feel in which way the motor is rotating.



**NOTE:** The blower will blow even if the direction of rotation is wrong but the result will be less than 25% of the rated capacity.

### Check the direction of rotation of the optional equipments

- Granulator with belt conveyor, – check direction of motion of the belt conveyor.
- Granulator with roll feed, – check direction of motion of the rollers.

### If any direction of rotation is wrong:

- Stop the granulator, press the “Stop”-button.
- Set the main power switch in position “0” Off.
- Ensure that the main supply is broken.
- Open the electric cabinet and shift two incoming phases to the main power switch.



**NOTE:** Sign the executed electric installation in the machine maintenance schedule.

## 5.5 Installation

### Adjust the granulator stand

Set up the granulator in the place of use.

Adjust so that the granulator cutter housing leveled horizontally.

Use a spirit level!



- Noise encapsulated machine open the doors.
- Open the door to the cutter housing. *see section 5.5*
- Open the hopper. *see section 5.5*  
Open the hopper only sufficiently for the spirit level that you are using.
- Close the door to the cutter housing properly. *see section 5.6*
- Adjust the horizontal position of the cutter housing in depth and sideways.  
Adjust the cutter housing using the machine shoes on the stand, use a spirit level.  
Adjust so that the cutter housing is accurately in horizontal level.

**NOTE:** The distribution of weight may not be altered when adjusting the machine shoes.

**NOTE:** If the granulator cutter housing is not accurately in horizontal level, it may be difficult to open and close the door to the cutter housing.



**IMPORTANT!** Make sure that all of the machine shoes carry load.

- Open the door to the cutter housing. *see section 5.5*
- Close the hopper, *see section 5.6*
- Close the door to the cutter housing properly, *see section 5.6*
- Noise encapsulated machine close the doors.



**NOTE:** Sign the executed installation in the machine maintenance schedule.

## 5.6 Actions before the first start

### Clean the granulator from anticorrosive agent.

Unpainted parts of the machine are treated with oil as protection prior to transportation and delivery. Clean the granulator from anticorrosive agent.

Remove the anticorrosive agent using low-aromatic White spirit or cold degreasing agent. Then wipe dry and clean with lintless rag.

### Check before the first start

- Ensure that the cutter housing is accurately in horizontal level.



**IMPORTANT!** Ensure that all of the machine shoes carry load.

- Ensure that at least one emergency stop knob is always within reach of the operator inside the working range of the granulator, including optional equipment for the granulator such as belt conveyor, shredder, dust filter, etc.
- Check tightening torque of screws to the knives.

Check tightening torque to the fixed knives:

- rear (no. 1), front (no. 2) and possibly third fixed knife . . . . . 600 Nm
- fourth and fifth fixed knife . . . . . 600 Nm

Check tightening torque to the rotating knives:

- granulator with 3-blade cutter . . . . . 600 Nm
- granulator with 5-blade cutter . . . . . 600 Nm

To check the knife clearance and tightening torque, read section 7.1 “Knife changing”.

- Check the knife clearance using a feeler gauge, check in the middle of the cutter housing and in the outer ends of the knives, the knife clearance must be 0.20 - 0.50 mm.



**NOTE:** Sign the executed inspection in the machine maintenance schedule.

### 5.6.1 Two hours after the first start

- 1 Check the tightening torque of all screws which are holding the granulator knives. First check the screws which are holding the fixed knives. Then check the screws which are holding the rotating knives.
- 2 Check the knife clearance between all rotating knives in the granulator against the rear and the front fixed knives (fixed knife no. 1 and fixed knife no. 2). The knife clearance must be 0.20 - 0.50 mm.
- 3 Check the screws which hold the granulator motor to the motor mounting bracket.

Motor power	screw	tightening torque
18.5 och 22.0 kW	M12 . . . . .	80 Nm
30.0; 37.0 och 45.0 kW	M16 . . . . .	200 Nm
55.0 kW	M20 . . . . .	400 Nm

(continued)

### 5.6.1 Two hours after the first start (continued)



**NOTE:** Sign the executed inspection in the machine maintenance schedule.

- 4 Check adjustment of the granulator motor mounting bracket, check the screws “G” and the nuts “H” to the adjusting screws. Check that the nuts to the adjusting screws are properly counter-tightened, and that they locks the setting of the motor mounting bracket. *see section 7.3*

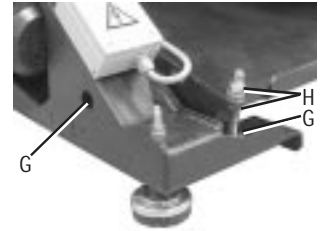

### 5.6.2 20 - 30 hours after the first start

- 1 Check condition and tension of the drive belts the first time after 20 to 30 hours at normal load. Checking and adjusting tension of the drive belts is described in section 7.3 “Transmission” in this instruction manual.
- 2 Check the tightening torque of the screws for the upper bracket of the jack against the hopper. Tightening torque 140 Nm.
- 3 Check the tightening torque of the screws for the lower bracket of the jack against the stand.

Jack 5000 N	M10 x 4 . . . . .	tightening torque 45 Nm.
Jack 15000 N	M20 . . . . .	tightening torque 300 Nm.
- 4 Check the tightening torque of the screws which holds the hopper against the rear hinge, tightening torque 200 Nm.
- 5 Check the tightening torque of the screws which holds the locking rule on cutter house door, tightening torque 200 Nm.
- 6 Ensure that the cutter housing is accurately in horizontal level.



**IMPORTANT!** Ensure that all of the machine shoes carry load.

- 7 Make a thorough general inspection. Ensure that there are no loose parts, screws, nuts or components on the machine. Consult your Conair agent/dealer or Conair’s Corporate office in Pittsburgh, Pennsylvania if there is any item that does not correspond to your expectations, or if there is any part of the machine that is faulty or that requires attention or repair.



**NOTE:** Sign the executed inspection in the machine maintenance schedule.

## 5.7 Open the cutter house door, hopper, granule bin and screen box



Immediately after opening the cutter house door and hopper, switch “Off” both the main power switch and the granulator switch.



Take care when the knives are accessible, they are sharp and could cause personal injury.

### Open the cutter house door

- 1 Stop the feeding of material to the granulator. Wait until all material in the granulator is complete granulated and the blower has emptied the granule bin and material conveyor system.
- 2 Stop the granulator, press the “Stop” button.
- 3 Noise encapsulated machine open the doors.
- 4 Loosen the coupling rings “J” on the outlet pipe. Move the coupling rings to the side and remove the short pipe stub.
- 5 Wait until the granulator cutter has stopped. A standstill monitor sense when the cutter has stopped.
- 6 The safety switch “K” holds the locking device to the cutter house door locked, until the standstill monitor sense that the granulator cutter has stopped. An indication lamp in the knob “Hopper operate I” on electrical cabinet and a green diode lamp on the safety switch lights, when the locking of the breaking key in the safety switch opens.

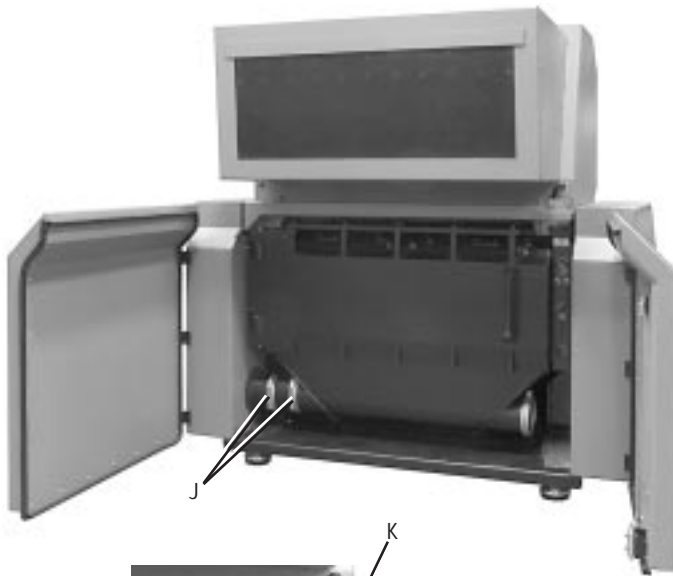

## 5.7 Open the cutter house door, hopper, granule bin and screen box

(continued)

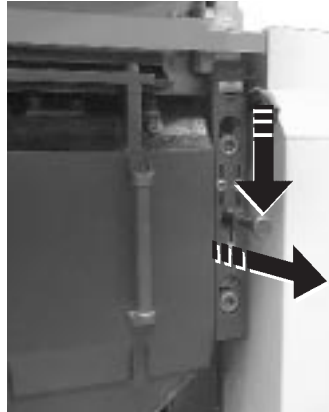

**7** First pull the lock handle outwards and then press the lock handle down.

**8** Unscrew the screws “L”, hex wrench 22 mm.

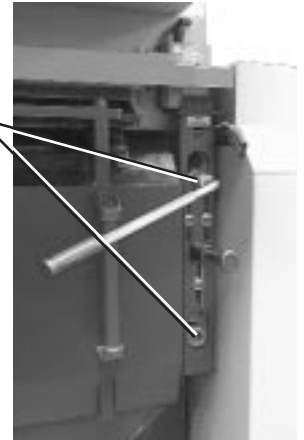

**9** First pull the lock handle outwards and then press the lock handle down.

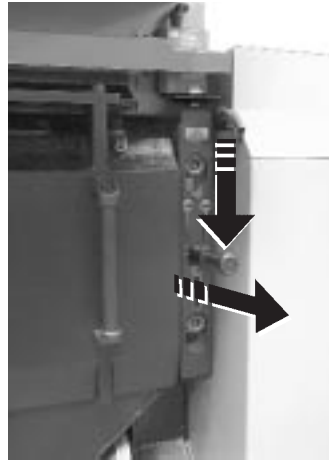

**10** Grip the door handle and open the door to the cutter housing.

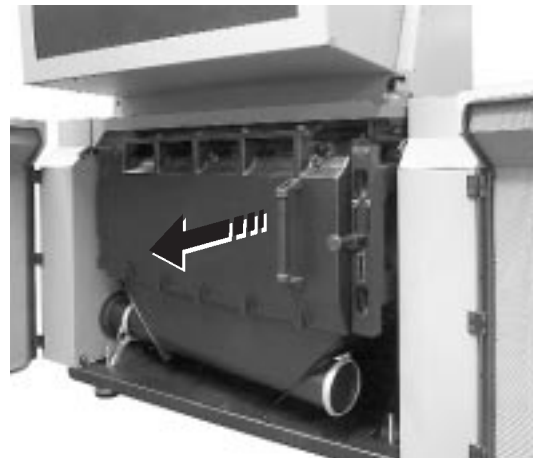

### Open the hopper

An electric jack opens the hopper. The jack is located inside the granulator.



**NOTE:** The the cutter house door must be opened, to enable the hopper to be opened.

**11** The safety switch by the granule bin checks that the cutter house door is opened.

A lamp lights in the right operating button “Hopper operate II” on the electrical cabinet, when the cutter house door is opened sufficiently to allow the hopper to be opened.

## 5.7 Open the cutter house door, hopper, granule bin and screen box

(continued)

- 12** The operation buttons for opening the hopper are located on the electrical cabinet.
- Set the knob "Hopper close/open" to "Open".  
The opening is two-hand controlled for safety reasons.
  - Ensure that the lamps in both the buttons "Hopper operate I" and "Hopper operate II" lights.
  - Press the buttons "Hopper operate I" and "Hopper operate II" simultaneously to open the hopper.  
A position switch senses and stops the opening action when the hopper is fully opened.
  - When the hopper opens the cutter lock is activated mechanically and brakes the cutter-belt pulley.

**13** Set the main power switch to position "0" Off.

**14** Unplug the granulator connector from the electric power supply.

**15** Press the emergency stop knob.

### Open the granule bin and screen box and changing the screen

The granule bin, screen and screen box are fitted inside the cutter housing.

**16** Open the cutter house door fully.

**17** Remove the granule bin "E". Grip the granule bin and pull it forward in the direction of the arrow.



**NOTE:** Hold the granule bin by a two-hand grip so that it does not fall without control.



**NOTE:** When the cutter house door and the hopper have been opened for service or maintenance, recommends that the cutter in the granulator covers by using a carpet.

This to avoid that any person can be injured in contact with the cutter.



**NOTE:** The the cutter house door must be opened, to enable access to the granule bin, screen and screen box.

## 5.7 Open the cutter house door, hopper, granule bin and screen box (continued)

**18** The screen “D” is easily accessible and can be lifted out, for replacement or cleaning.

**19** The screen box “M” is also easily accessible and can be lifted out easily, for cleaning.



Fantastic! the CW granulator features excellent accessibility.



**NOTE:** The screen box is heavy. Hold the screen box so that it does not fall without control.



**NOTE:** NOTE! The screen box is heavier than you think.

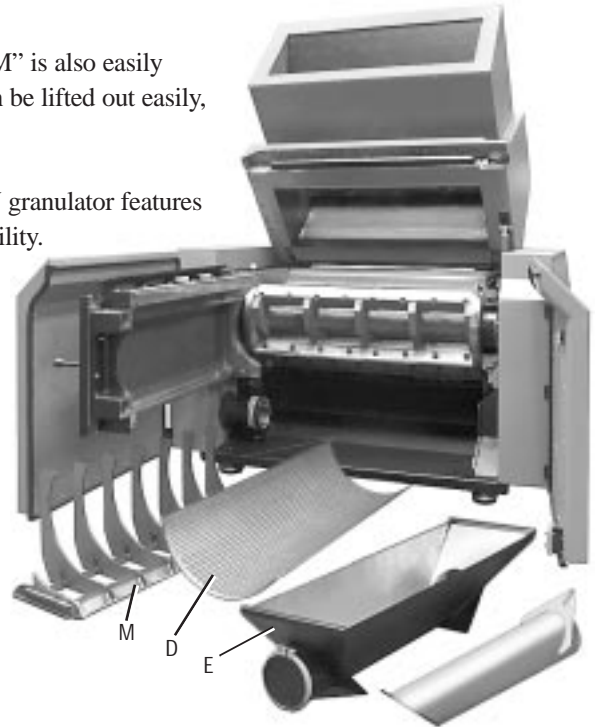

## 5.8 Close the screen box, granule bin, cutter house door and hopper



**NOTE:** Ensure that all surfaces that make contact with one another are well cleaned before closing.



Observe caution because there is danger of being crushed when closing.

### Install the screen box and screen

#### 1 Install the screen box “M”.



**NOTE:** The screen box is heavy.

Take a firm two-hand grip on the screen arcs of the screen box, lift and slide in the screen box in the guides on the cutter house door.



**NOTE:** Push in the screen box firmly to stop.

#### 2 Lift the screen “D” into the screen box and adjust it sideways.



Then, with both hands, push in the lower edge of the screen. The screen then follows the screen arcs, make sure and check that the two recesses in the screen falls in into the positions, on the two lugs on the outer screen arcs.

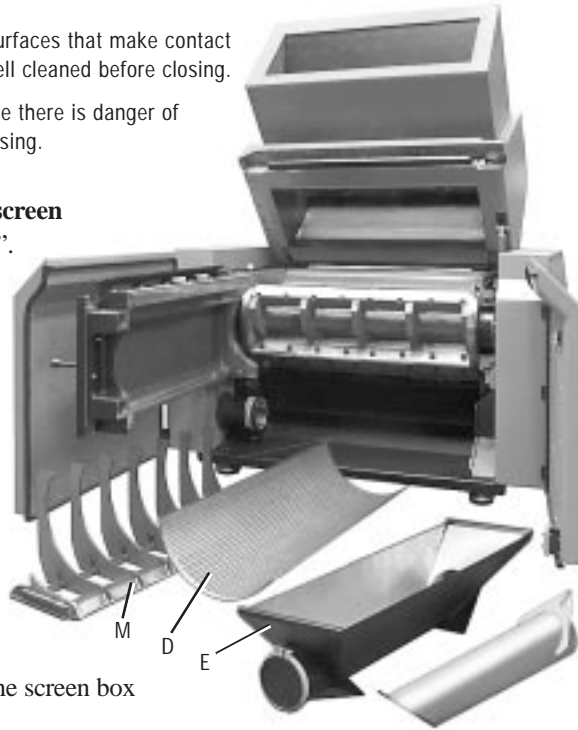

## 5.8 Close the screen box, granule bin, cutter house door and hopper (continued)

### Install the granule bin

**3** 1836 and 1848 Fit the distribution plate in correct direction inside the granule bin.

**4** Install the granule bin “E”. Take a firm two-hand grip on the granule bin, lift and slide the granule bin in on the guides on screen box.



**NOTE:** Push in the granule bin firmly to stop.

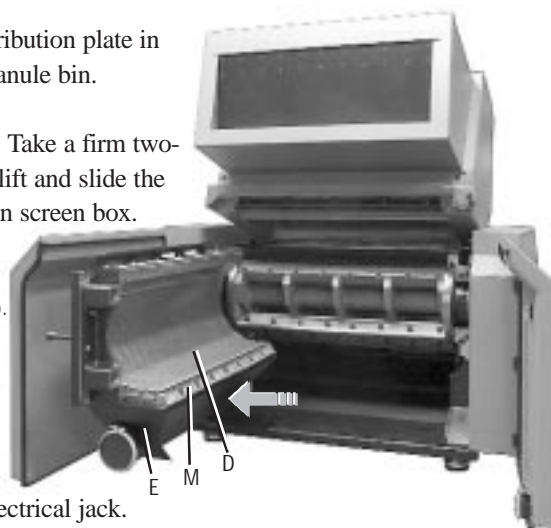

### Close the hopper

The hopper is closed by an electrical jack.

The jack is located inside the granulator.

**4** Plug in the granulator connector to the main power supply.

**5** Set the main power switch to position “1” On.

**6** Reset the emergency stop knob.



**7** **NOTE:** The cutter house door must be opened, to enable the hopper to be closed.

- The safety switch by the granule bin checks that the cutter house door is opened.

**8** The operation buttons for closing the hopper are located on the electrical cabinet.

- Set the knob “Hopper close/open” to “Close”.

The closing is two-hand controlled for safety reasons.

- Ensure that the lamps in both of the buttons “Hopper operate I” and “Hopper operate II” lights.

- Press the buttons “Hopper operate I” and “Hopper operate II” simultaneously to close the hopper.

A limit switch senses and stops the closing action when the hopper is fully closed.

- When the hopper closes, the cutter lock opens mechanically to release the cutter.

## 5.8 Close the screen box, granule bin, cutter house door and hopper (continued)

### Close the cutter house door

 **9** **NOTE:** The hopper must be closed before closing the cutter house door.

 **NOTE:** Never use help when closing the door to the cutter house.

 Close the door to the cutter house alone. The cutter house door is heavy! The risk of injuring fingers or hands increases when two or more persons works, to close the cutter house door. Be careful!

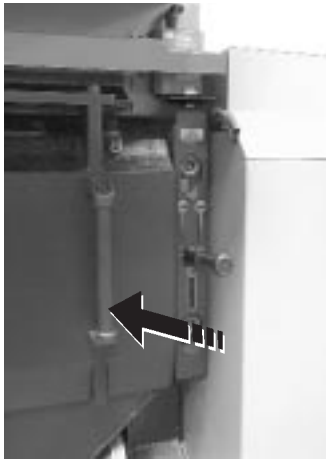

**10** Close the cutter house door.

**11** First pull the lock handle outwards and then lift the lock handle upwards.

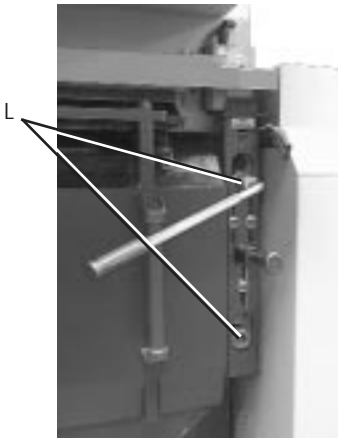
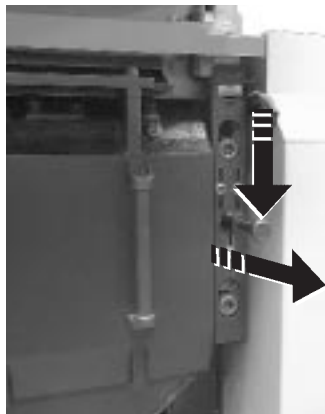

**12** Fasten the screws “L”, hex wrench 22 mm.

## 5.8 Close the screen box, granule bin, cutter house door and hopper (continued)

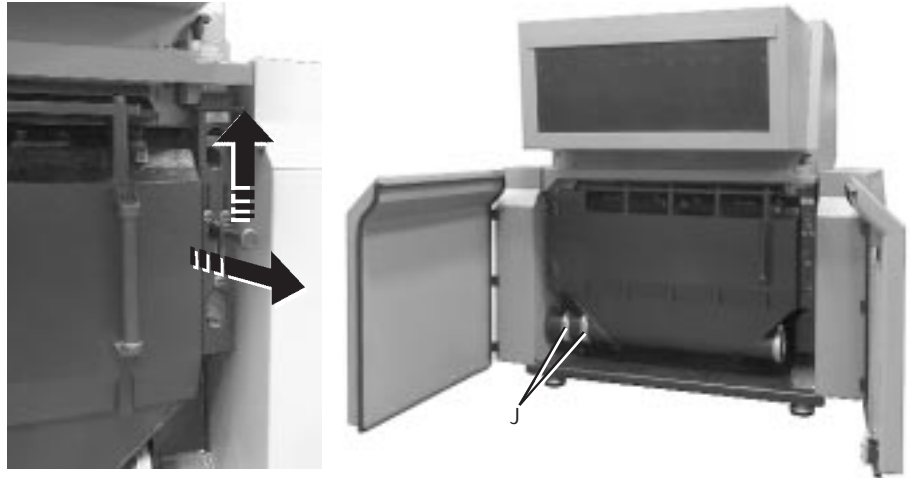

- 13** First pull the lock handle outwards. Then lift the handle upwards so that the breaking key enters the safety switch.
- 14** Install the short pipe stub with the coupling rings “J” to the outlet.
- 15** Noise encapsulated machine close the doors.
- 16** Reset the safety relay. The blue lamp in the button lights when the safety relay is reset.



- 17** Start the granulator.

# Operation and Daily Maintenance

---

6.1	Start and stop .....	6-2
	– Start .....	6-2
	– Stop .....	6-3
6.2	Inspection .....	6-4
	– Daily inspection .....	6-4
	– Weekly inspection .....	6-4
	– Monthly inspection .....	6-5
	– Inspection every 3 month .....	6-5
	– Inspection every 6 month or 1000 running hours .....	6-5
6.3	Stoppage and overloading of granulator .....	6-7
	– Stoppage in cutter housing .....	6-7
	– Stoppage in blower .....	6-8
	– Stoppage in hopper .....	6-8
	– Stoppage in material conveyance system .....	6-8
6.4	Cleaning .....	6-10
	– Re-install after cleaning .....	6-13
6.5	Fault finding .....	6-15
	– The granulator does not start .....	6-15
	– The granulator stops for some unaccountable reason ...	6-16
	– The cutter house door can not be opened .....	6-17
	– The hopper can not be opened .....	6-17
	– Granulator with band conveyor the conveyor does not start .....	6-18

## 6.1 Start and stop

The main switch is located on the electrical cabinet. Starting and stopping is controlled by push buttons on the control panel.

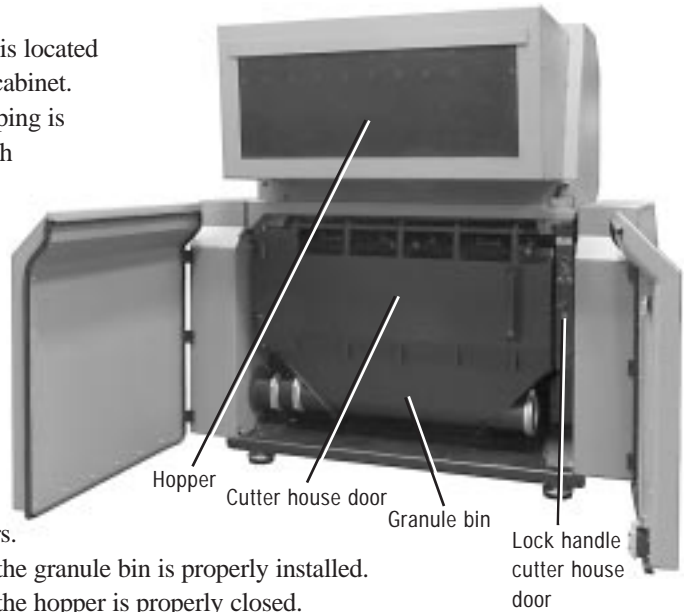

### Start

- Open the doors.
  - check that the granule bin is properly installed.
  - check that the hopper is properly closed.
  - check that the cutter house door is properly closed.
  - check that the lock handle to the the cutter house door locks the cutter house door properly.
  - check that the socket cap screws inside the locking device are properly tightened.

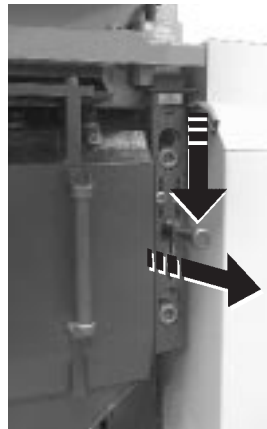

First pull the lock handle outwards and then press the lock handle down.



Check the screws, hex wrench 22 mm.

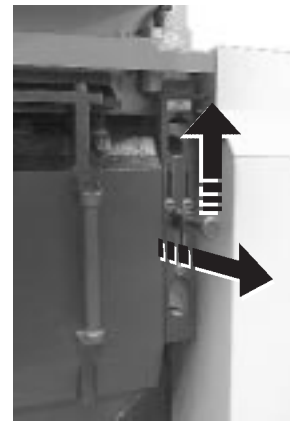

First pull the lock handle outwards. Then lift the lock handle upwards so that the breaking key enters the safety switch.

## 6.1 Start and stop (continued)

- Close the doors.
- Check that the extraction blower is connected properly.
- Turn the main switch to position “1” On.
- Check that the emergency stop is not activated.
- Reset the safety relay, press “Reset safety relay”.
- Start the granulator, press the “Start” button.



Conair recommends that ear protections are used during all granulation of plastics. Granulation of hard plastic, big plastic details, or plastic lumps can cause high and dangerous sound.



Observe also that low sound levels during a long time is dangerous.

Conair recommends that safety goggles are used during all granulation of plastics.

### Stop

Stop the feeding of material to the granulator.



**NOTE:** Then wait until all material in the granulator are completely granulated and the blower have emptied the granule bin and material conveyance system from granulate.

If the granulator is stopped with material left in hopper, cutter housing, granule bin or transport system the residual material will clog the cutter in the granulator and the material conveyance system during re-start.

Residual material will break the cutter in the granulator or the blower during re-start. The granulator motor or the blower motor will be overloaded and any of the overloading protections will trigger.



**NOTE:** A manual cleaning of the granulator, hopper, screen, screen box, granule bin, fan and material conveyance system are then nec restart.

- Stop the granulator, press the “Stop”-button.
- Turn the main switch to position “0” Off.
- Pull the mains plug out of the mains outlet.
- Press the emergency stop-button.



## 6.2 Inspection

There must be no plastic material left in the granulator when inspection is carried out.



**NOTE:** All servicing must be done by trained personnel in order to avoid personal injury and damage to the machine.

### Daily inspection

**Flaps in the hopper.** Check that the flaps are undamaged. Replace damaged flaps at once. Damaged flaps can drop down into the cutter housing and damage the knives. Damaged flaps also entail the risk of material ejection.

**Emergency stop.** Check the emergency stop function. Start the granulator and stop it with the emergency stop(s).

**Reset.** Turn the stop button in the direction of the arrow (counterclockwise).

### Weekly inspection

**Cables.** Check the electric cables of the machine for wear or other damage. Replace damaged cables at once.

**Safety switches.** Check the function of the safety switches. This granulator has 2 safety switches:

- 1 at the hopper, between the hopper and cutter housing.
- 1 at the granule bin.

Check the hopper safety switch.

- Open the doors.
- Pull out and press the lock handle down 1 step.
- Close the doors and try to start the granulator.
- It should not be possible to start the granulator before the hopper and the cutter house door are properly closed.
- Lock the cutter house door and close the granulator properly.

Check the granule bin safety switch.

- Open the doors.
- Open the cutter house door and remove the granule bin.
- Close the cutter house door properly.
- Close the doors and try to start the granulator.
- It should not be possible to start the granulator without the granule bin.
- Install the granule bin and close the granulator properly.

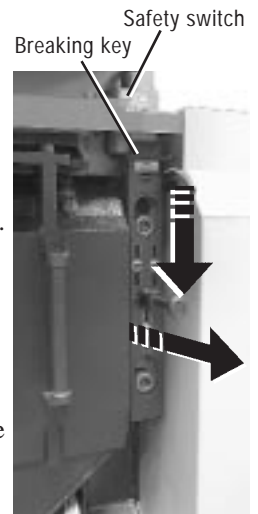

**NOTE:** Sign the executed inspection in the machine maintenance schedule.

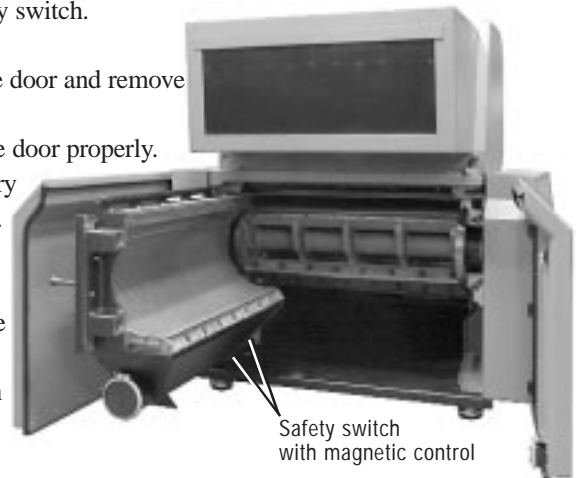

## Monthly inspection

- 1 Check the function of the cutter lock. Check that the cutter lock is automatically activated and that the cutter brakes when the hopper opens.
- 2 Check that the standstill monitor keeps the lock handle to the cutter house door locked so long time as the cutter is in motion.



**NOTE:** Sign the executed inspection in the machine maintenance schedule.

## Inspection every 3 months

- 1 The drive belts should be inspected every three months. Check the condition of the drive belts and that they are intact. *see section 7.3*
- 2 Check the hinges to the cutter house door every three months. Check the position of the lower hinge pin. The hinge pin may never fall down or be visible at the bottom of the cutter house door. Should the hinge pin fall out of position, use a hammer and a piece of wood between to knock/hammer the pin back up into position flush with the bottom of the door.



**NOTE:** Sign the executed inspection in the machine maintenance schedule.

## Inspection every 6 months or 1000 hours of operation

- 1 Check that the granulator stands steady and that the cutter house is accurately in horizontal level, read section 5.3.
- 2 Check that all of the machine shoes carry load.



**IMPORTANT!** Make sure that all of the machine shoes carry load.

- 3 Check tension of the drive belts. *see section 7.3 "Transmission"*
- 4 Check the screws holding the granulator motor to the motor mounting bracket.

Motor power	screw	tightening torque
18.5 and 22.0 kW	M12 .....	80 Nm.
30.0; 37.0 and 45.0 kW	M16 .....	200 Nm.
55.0 kW	M20 .....	400 Nm.

- 5 Check the adjusting screws and the nuts to the granulator motor mounting bracket.
  - Check that the nuts are properly counter tightened, so that they locks the setting of the adjusting screws. *see section 7.3*
- 6 Check the tightening torque of the screws to the upper mounting of the jack against the hopper.  
Tightening torque 140 Nm.

## 6.2 Inspection (continued)

- 7** Check the tightening torque of the screws to the lower mounting of the jack against the stand.
- |      |         |         |       |                           |
|------|---------|---------|-------|---------------------------|
| Jack | 5000 N  | M10 x 4 | ..... | tightening torque 45 Nm.  |
| Jack | 15000 N | M20     | ..... | tightening torque 300 Nm. |
- 8** Check that oil is not leaking from the jack gear housing.
- 9** Check the tightening torque of the screws which holding the hopper against the rear the hinge part, tightening torque 220 Nm.
- 10** Check the tightening torque of the screws which holds the locking rule to the cutter house door, tightening torque 220 Nm.
- 11** Make a thorough general inspection.
- Check so that there are no loose parts, screws, nuts or components on the machine.
- 12** Check general wear of the granulator.
- Check the granulator inside and all functional parts.
  - Check also parts not normally subjected to wear.
- 13** If the granulator is equipped with a cutter-belt pulley or a flywheel with friction clutch.
- Check the tightening torque of the screws in the friction clutch.  
*see section 11.2*  
Tightening torque 20 Nm.
-  **14** Check the granulator optional equipments.
- ..... Check function and general wear.

**NOTE:** Sign the executed inspection in the machine maintenance schedule.

## 6.3 Stoppage and overloading of granulator

### Stoppage in cutter housing

#### Cutter stoppage

If the granulator is overloaded so that the cutter has jammed.

Open the cutter house door carefully, then undo and remove the granule bin, screen and screen box. Opening *see section 5.7*.

Open the hopper carefully, opening *see section 5.7*.

If the cutter has jammed, use a wooden pole and carefully try to release the cutter in reverse rotational direction.

Clean the hopper, cutter housing, screen, screen box and granule bin.

Reset the granulator motor's overload protector in the electrical cabinet – *see section 6.5 "Fault-finding"*.

#### Overfilling in cutter housing

Look for and attend to the cause of overfilling in the granulator.

- Check the hopper, granule bin and outfeed (blower, transport pipe, cyclone filter etc.).
- Check the knives and knife tolerance. If the granulator knives are blunt and un-sharpened, or if the knife clearance is incorrect, this can cause overfilling in the cutter housing.

Check the knives. Sharpen or replace the knives, or adjust the knife clearance. *see section 7.2 "Sharpening of knives"*

- Check the drive belts. If the tension of drive belts is too low, the transmission will slip and the cutter's rotational speed will drop too low – this can cause overfilling in the cutter housing.

Clean the hopper, cutter housing, screen, screen box and granule bin.

Reset the granulator motor's overload protector in the electrical cabinet – *see section 6.5 "Fault-finding"*.

- Check the granulator's screen. The dimensions of the holes in the granulator's screen must be appropriate to the material to be granulated, and if the size of the holes is wrong this can lead to overfilling in the cutter house.

Contact Conair's local distributor or Conair's head office.

#### Hardened lumps in the cutter housing, screen box and granule bin

If the cutter housing, screen box, screen and granule bin are filled with compacted stiffened/hardened plastic.

Contact Conair's local distributor or Conair's head office.



**NOTE:** Before troubleshooting, attending to mechanical faults and maintenance work, switch "Off" the granulator main switch and "Break the power supply" to the granulator and the granulator optional fittings.



**NOTE:** Never use metal objects to try and release a jammed cutter. This can damage the cutter, knives, knife positions, support rules and cutter housing.

By heat-treating the cutter housing and screen box the plastic can be melted away. In order to be able to apply heat treatment, the cutter housing must be removed from stand, hopper and enclosure.

This is work which can be carried out by Conair's service department at the head office.

A change of bearings is always necessary after heat treatment.

The granule bin, screen and screen box must be changed.

After dismantling the cutter housing the granule bin must be removed.

A granule bin filled with stiffened/hardened plastic can in most cases only be removed by means of cutting treatment.

A granule bin filled with stiffened/hardened plastic cannot be heat-treated without the fit changing.

These parts cannot be re-used after the heat treatment.

An alternative way of removing hardened plastic is by means of mechanical treatment. Removing hardened/stiffened plastic mechanically is very time-consuming. Furthermore, there is a big risk of damaging the rotor, knives, knife positions, support rules, cutter housing and screen.

### **Stoppage in blower**

Look for and attend to the cause of the stoppage in the blower.

- Check there is no stoppage in the transport pipes, cyclone, dust filter and collecting container.  
Clean and empty transport pipes, cyclone, dust filter and collecting container.
- Check that the blower rotational direction is in accordance with the arrow on the blower hood.

### **Stoppage in hopper**

Look for and attend to the cause of the stoppage in the hopper.

- The hopper feed speed is too high or pieces too large.  
Clean the hopper and lower the feed speed.
- The cutter housing is overfilled.  
Look for and attend to the cause of the overfilling in the cutter housing – see previous section.

### **Stoppage in material conveyance system**

Look for and attend to the cause of the stoppage in the material conveyance system.

- Overfilling or stoppage in the granule bin, transport pipes, cyclone, dust filter or collecting container.  
Clean and empty transport pipes, cyclone, dust filter and collecting container.



**NOTE:** The blower blows even if the rotational direction is wrong, but capacity will be less than 25%.

- Check that the blower's rotational direction is in accordance with the arrow on the blower hood.



**NOTE:** The blower blows even if the rotational direction is wrong, but capacity will be less than 25%.

### **Smell of melted plastic and smoke formation**

- Overfilling or stoppage in transport pipes, cyclone, dust filter or collecting container.

The blower functions easily and the granulator grinds plastic into powder and subsequently into a hot mass.



**WARNING!** If the granulator is turned off, the result will be hardened lumps in the cutter house.

Read the section on hardened lumps in the cutter housing.



**WARNING!** Risk of fire in the cutter house.



**NOTE:** Do NOT turn off the granulator. Try to attend to, release and evacuate the stoppage in transport pipes, cyclone, dust filter or collecting container.

Then clean and empty the granule bin, transport pipes, cyclone, dust filter and collecting container.

## 6.4 Cleaning

Clean when changing, monthly or at least once every 300 hours of operation.



**WARNING! Granulate and plastic rests on the floor can cause risk of slipping!**



**Risk of slipping depending of granulate and plastic rests, is especially hazardous during cleaning, when the cutter house door is opened. Be careful!**

Use a vacuum cleaner when cleaning the granulator.

Do not use compressed air and a blow nozzle.

Because then you must also clean the surroundings, after cleaning the granulator.



**NOTE:** Never use help when cleaning the granulator.  
Carry out the cleaning alone and observe caution!

The risk of injuring fingers or hands increase if two or more persons are used to clean the granulator.



Be careful when the hopper and the cutter house door are opened.

The knives are then accessible, they are sharp and could cause personal injury.



Always use protective goggles and protective gloves during cleaning!



Ensure so that no material enters the safety switches!

Read section 6.1 “Start and stop” and section “Stop”.



Wait until the granulator and material conveyor system are empty of granulate.

## 6.4 Cleaning (continued)

Read section 5.7 “Open the cutter house door, hopper, screen box and granule bin” which describes how to open the granulator. Then follow the points below.

- 1 Stop the granulator
  - press the ”Stop”-button.
- 2 Clean the flaps in the hopper.
  - With extraction fan and soundproofing fold the forward flap inwards and up 90°, grip the forward list and pull the flap-package straight out.



**NOTE:** The flap package with extraction fan and sound proofing machine is heavy!



If the flap package drops there is risk of personal injury and damage



- With extraction fan, sound proofing, and conveyor pull out the outer flaps and the inner flaps.
- With extraction fan, sound proofing for sheet material profiles. Do not remove the flap, clean the flap when the hopper is opened.

## 6.4 Cleaning (continued)

- 3 Noise encapsulated machine open the doors.
- 4 Undo the coupling rings to the outlet.  
Move the coupling rings to side and remove the short outlet stub.

5 Open the cutter house door.

6 Open the hopper.



- 7 Break power supply to the granulator.
  - turn the main switch to position “0” Off
  - pull the main plug out of the main outlet
  - press the emergency stop-button

8 Clean the inside of the hopper

9 Clean the outside of the hopper.

10 Remove and clean the granule bin. 1836 and 1848 clean also the distribution plate inside the granule bin.



11 Lift out and clean the screen.

12 Lift out and clean the screen box.

13 Clean the inside of the cutter house door.

14 Clean the inside of the cutter housing.



The knives are heavy and sharp and could cause personal injury.

15 Clean the outlet pipes, from the outlet pipe stub against the granule bin and all the way to the blower inlet. If plastic lumps or material are sucked into the blower at re-start, the blower can be seriously damaged and must be replaced.

16 Granulator with band conveyor. Clean the belt using a light cleaning agent.



The CW granulator features an excellent accessibility for quick cleaning.



**NOTE:** Hold the screen box so that it does not fall out of control.



**NOTE:** NOTE! the screen box is heavier than you think.



**NOTE:** If the cutter lock is released, to manually rotate the cutter, do this with very great care!



**NOTE:** It is very important that there is no material left in the transport pipes or in the blower inlet pipe.

## Re-install after cleaning



**NOTE:** There is a pinch risk during closing, be careful.

**1** Install the screen box. Take a firm two-hand grip on the screen arcs of the screen box, lift and slide in the screen box in the guides on the cutter house door.



**NOTE:** Push in the screen box firmly to stop.

**2** Install the the screen.

**3** Install the granule bin. 1836 and 1848 — Fit the distribution plate in correct direction inside the granule bin. Take a firm two-hand grip on the granule bin, lift and slide the granule bin in on the guides on the screen box.



**NOTE:** Push in the granule bin firmly to stop.

**4** Clean the outside of the cutter housing and all the mating surfaces during closing.

**5** Close the hopper.



**NOTE:** The hopper is closed by an electrical jack.

**NOTE:** The cutter house door must be opened, to enable the hopper to be closed.

**6** Plug in the granulator connector to the mains power supply.

**7** Turn the main switch to position “1” On.

**8** Reset the emergency stop knob.

**9** The operation buttons for closing the hopper are located on the electrical cabinet.

- Ensure that the lamps in both of the buttons “Hopper operate I” and ”Hopper operate II” lights.
- Set the knob “Hopper close/open” to “Close”.
- Press the buttons “Hopper operate I” and ”Hopper operate II” simultaneously to close the hopper.





**NOTE:** The hopper must be closed, before closing the cutter house door.



**NOTE:** Never use help when closing the cutter house door. Close the cutter house door alone!

**10** Close the cutter house door.



The cutter house door is heavy. The risk of injuring fingers or hands increases when two or more persons work, to close the cutter house door.

**Be careful!**

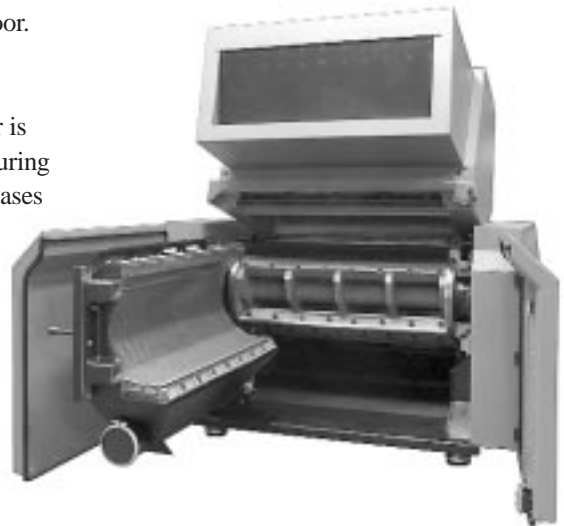

**11** Install and fasten the short pipe stub with the coupling rings.

**12** Clean and make sure that there are no granulate left in the space outside the cutter housing and inside the granulator encapsulating before closing the doors.

**13** Close the doors.

**14** Install the flaps in hopper.

- Unit with extraction fan and sound proofing: Fold the forward flap 90° upwards, lift and slide the flap package straight in.
- Unit with extraction fan, sound proofing, and conveyor: Install the inner flap and the outer flaps.



**NOTE:** Check and make sure that there are no granulate and plastic residue left on the floor after cleaning.

**Warning! Granulate and plastic rests cause slipping risk!**

**15** Check that the hopper is empty.

**16** Turn the main switch to position “1” On.

**17** Check that the emergency stop not is activated.

**18** Reset the safety relay, press the “Reset safety relay” button.

**19** Start the granulator, press the “Start” button.



## 6.5 Fault finding

The granulator does not start

- Check the main switch.  
Turn the main switch to position “1” On.
- Reset the safety relay, press the “Reset safety relay”-button.  
The granulator will not start, if the safety relay not is reset.  
The cutter lock keeps the cutter braked until the safety relay is reset.  
Reset the safety relay and start the granulator.  
The blue lamp in the button lights when the safety relay is reset.
- Check if the emergency stop is activated.  
Reset, turn the button(s) in the direction of the arrow (counterclockwise).
- Check the granulator safety switches.  
The granulator will not start if any of the safety switches breaks the control current to the granulator.

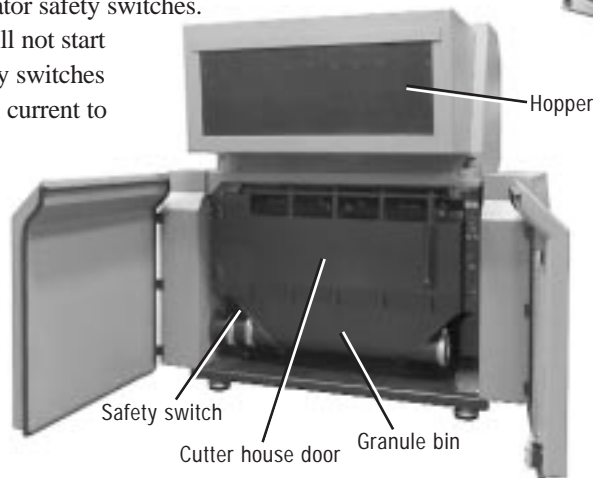

Open the doors and check that:

- the hopper and cutter house door are properly closed.
- the granule bin is properly installed.
- the locking device on the cutter house door is properly closed.

First pull the lock handle outwards. Then lift the lock handle upwards and check so that the breaking key has entered the safety switch.

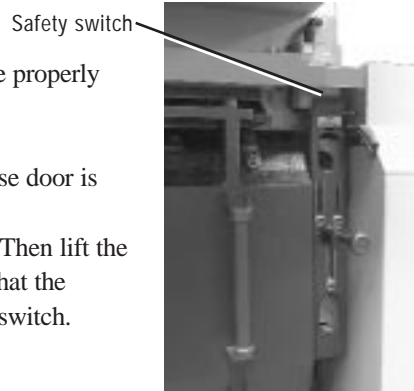

- Check so that there is no material in the hopper or cutter housing before start. If there is material in hopper or cutter housing, the granulator cutter will be impeded at start. The granulator motor will be over loaded and the overload circuit breaker trips.

Clean the granulator.

Check the overload circuit breaker “F1” for the granulator motor in the electrical cabinet.

If the overload circuit breaker trips shows “0” in the window “A”.

Reset, press the “Reset” button “B”.

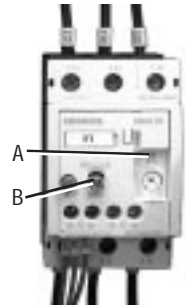

- Granulator with blower the granulator will not start, if the extraction blower does not start.

Check the motor protection switch “Q2” in the electrical cabinet to the extraction blower.

If the motor protection switch has switched “Off”, the switch knob is standing in a position between “0” and “1”.

Reset – first turn the switch knob to position “0” and then to position “1”.

Check so that there is no material in the cutter housing, granule bin or conveyor system before start.

If there is material in cutter housing, granule bin or conveyor system, the blower motor will be impeded at start. The blower motor will be overloaded and the motor protection switch trips.

Re-start the granulator, granule bin and conveyor system.

Re-start the granulator.



- If the granulator is equipped with a speed monitor, and if the cutter does not reach the correct speed after start, the granulator stops, the speed monitor trips.

Check that there is no material in the hopper or cutter housing before start.

If there is material in hopper or cutter housing, the cutter will be impeded and does not reach correct speed, the speed monitor trips.

Clean and restart the granulator.

Ensure that the drive belts are not slipping.

The speed monitor has no reset.



**The granulator stops for some unaccountable reason**

- Check the overload circuit breaker for the granulator motor  
The granulator motor has an overload circuit breaker, “F1”, in the electrical cabinet, which trips if you jam or overload the granulator.  
Check the overload circuit breaker “F1” for the granulator motor in the electrical cabinet.

If the overload circuit breaker trips shows “0” in the window “A”.

Reset, press the “Reset” button “B”

Clean the granulator before re-start.

- Check the granulator knives and knife tolerance.  
If the granulator knives are blunt and unsharpened, or if the knife clearance is incorrect, this can result in stoppage. The granulator motor overload circuit breaker will trip.  
Check the knives. Sharpen or replace the knives, or adjust the knife clearance, see next section.
- If the granulator is equipped with a speed monitor and the cutter speed falls too low during granulating, the speed monitor will trip.  
Ensure that the drive belts are not slipping.  
The speed monitor has no reset.  
Clean and restart the granulator.
- If the drive belts tension not is enough, the transmission will slip and the granulator motor overload protection trips.  
Check and adjust the drive belt tension. *see section 7.3 “Transmission”*
- At a bad or loose contact in connection to a safety switch/limit switch, the granulator will stop.  
Call for an qualified electrician for fault-finding and appropriate measures.



**NOTE:** Never bypass a safety switch or limit switch.

### **The cutter house door can not be opened**

- The door to the cutter housing cannot be opened if the cutter is in motion.  
The granulator cutter must stop, before the cutter house door can be opened.  
The granulator has a standstill monitor which senses inductively, when the cutter has stopped.  
The standstill monitor locks the breaking key to the locking device on cutter house door, so long time as the cutter is in motion.  
An indication lamp in the knob “Hopper operate I” on electrical cabinet and a green diode lamp on the safety switch lights, when the locking of the breaking key in the safety switch opens.

### **The hopper can not be opened**

- Check the main switch.  
Turn the main switch to position “I” On.
- The granulator cutter must stop and the cutter house door must be properly open, before the hopper can be opened.  
Check that the lamps in both the buttons “Hopper operate I” and “Hopper operate II” lights.
- Check so that no emergency stops are activated.

- The hopper screw jack has an motor protection switch “Q4”, in the electrical cabinet, which trips if you overload the jack.  
If the motor protection switch has switched “Off”, the switch knob is standing in a position between “0” and “1”.  
Reset – first turn the switch knob to position “0” and then to position “1”.



**Granulator with band conveyor the conveyor does not start**

- Check the main switch.  
Turn the main switch to position “1” On.
- Check so that no emergency stops are activated.
- Check that the connector to the band conveyor is connected to electrical cabinet.
- Check the band conveyor motor protection switch “Q3” in the electrical cabinet, it trips, if you run to stop or overload the conveyor belt.  
If the motor protection switch has switched “Off”, the switch knob is standing in a position between “0” and “1”.  
Reset – first turn the switch knob to position “0” and then to position “1”.  
Clean and make sure that there is no material left on the conveyor belt before re-starting.



**NOTE:** Check also the wiring diagram, supplements and deviations may be applicable.

# Service

---

7.1	Knife changing	7-2
-	Length, dimensions and strength class on screws	7-3
-	Tightening torque and torque wrench	7-3
-	Check the type of cutter housing	7-3
-	Rotating knives	7-3
-	Fixed knives	7-4
-	To change the knives	7-4
-	Screws and nuts with red marking	7-5
-	Removing of knives	7-5
	Removing of rotating knives	7-5
	Removing of fixed knives	7-6
-	Installing of knives	7-9
-	Pre-setting of knives	7-9
-	Pre-setting	7-10
-	Installing of pre-set knives	7-10
	First install the fixed knives	7-11
	Installing of rotating knives	7-14
-	Check the knife installation	7-16
-	4 - 8 hours after knife changing	7-16
7.2	Grinding of knives	7-17
-	Cool the knives when you grind them	7-17
-	Grinding fixture	7-17
-	First grind the relief angle	7-18
-	Then grind the cutting angle on the knife edge	7-18
-	Grinding rotating knives	7-18
-	Grinding of rear fixed knife no. 1, front fixed knife no. 2, the fourth and fifth fixed knife	7-19
-	Grinding the third fixed knife	7-21
7.3	Transmission	7-22
-	Inspection of the drive belts	7-22
-	Checking and adjustment of the drive belt tension	7-23
7.4	Lubrication	7-25
7.5	Cutter lock	7-26

## 7. Service



**NOTE:** When the cutter house door and the hopper have been opened for service or maintenance, recommends that the cutter in the granulator covers by using a carpet.

All service must be carried out by trained personnel in order to avoid personal injury or damage to the machine.

### 7.1 Knife changing



**NOTE:** Make sure that there never are any granulate or plastic rests on the floor during changing of knives.

**WARNING! Granulate and plastic residue on the floor can cause risk of slipping!**

**If anyone slips or falls during changing of knives, or handling of knives, it can cause serious personal injury.**



**NOTE:** The granulator is equipped with a cutter lock!

**NOTE:** Before starting to change the knives! Check that the cutter lock of the granulator brakes the cutter, immediately after the hopper is opened!

#### **WARNING!**

**NOTE:** When you release the cutter lock, the cutter auto-rotates, for instance at removing or installing of rotating knives.



The cutter auto-rotates when the center of gravity becomes unstable when removing or installing knives. So therefore be careful when changing knives, so as not to injure fingers or hands.



**OBSERVE! Never resort to help when removing or installing rotating knives. Always carry out knife changing alone, so as to minimize the risk of injury to fingers or hands.**

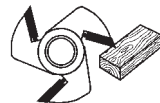

**The cutter lock brakes the cutter belt pulley, but for safety reasons, when screws on knives are removed or installed with tightening torque, always secure the cutter to the cutter housing using a strong block of wood, to avoid that the brake can glide. Be careful when handling the knives, they are sharp and can cause personal injury.**



Always use protective gloves when changing knives!

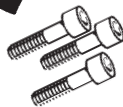

Each time the set of knives is changed, the screws which hold the knives must be replaced by new ones.

Every second time re-sharpened knives are installed, the screws which hold the knives must be replaced by new ones.



When installing rotating knives, always install all the rotating knives on the cutter, so that the cutter will be balanced.

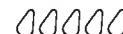

Check the screen for wear when the knives are changed.

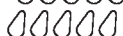

Change the screen when the holes begin to be pear shaped.

## 7.1 Knife changing (continued)

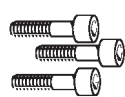

### Length, dimension and strength class on screws

All screws which retain the knives are of high strength class.

Only screws supplied by Conair may be used for installing knives.



Conair's responsibility and guarantee become invalid unless genuine Conair screws of the right length, dimension and strength class are used.

### Tightening torque and torque wrench

It is very important that the knives are torqued to correct tightening torque.

All screws must be tightened using a torque wrench to the specified tightening torque which is stated in the machine instruction manual.

If a torque wrench is not used or if screws are not tightened to the specified tightening torque which is stated in the machine instruction manual, Conair's responsibility and guarantee become invalid.

### Check the type of cutter housing

Check which type of cutter housing your granulator have and how many fixed knives it is equipped with.

Fixed knife  
no. 2 and no. 4

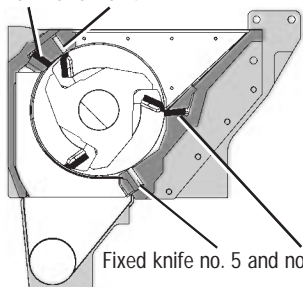

Fixed knife  
no. 2 and no. 4

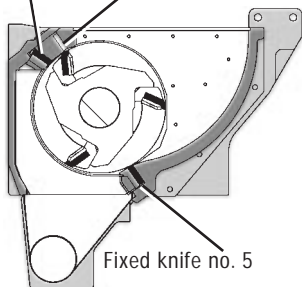

Fixed knife  
no. 2, no. 4 and no. 3

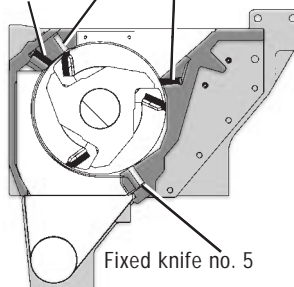

Your CW Conair granulator reflects a high technical level, and is manufactured with such a precision that all knives in the granulator can be pre-set before they are installed in the cutter housing. With a knife clearance precision of 0.20 mm.



**NOTE:** Both fixed and rotating knives!

### Rotating knives

The rotating knives, 3-blade cutter and 5-blade cutter, are installed with support rules, one pair per rotating knife pair.

Tightening torque 600 Nm.

The rotating knives have fixed set knife positions in the cutter.

The knife clearance for the knives 0.20 - 0.50 mm is set with an pre-setting fixture, before the knives are installed in the knife positions in the cutter.

An pre-setting fixture of the compact model type, for pre-setting of the rotating knives art. no. 3-45470 is delivered in the granulator tool bag.

A bigger pre-setting fixture more exact art.no. 3-45082 is available as an option.

# 7.1 Knife changing (continued)

## Fixed knives

The fixed knives are installed with support rules, one pair per fixed knife pair.

Tightening torque 600 Nm.

The fixed knives have fixed set positions in the cutter housing/cutter house door.

The knife clearance for the knives 0.20 - 0.50 mm is set with an pre-setting fixture, before the knives are installed in the knife positions in the cutter housing/cutter house door.

A pre-setting fixture of the compact model type, for pre-setting of the fixed knives art. no. 3-45470 is delivered in the granulator tool bag.

A bigger pre-setting fixture more exact art.no. 3-45082 is available as an option.

## To change the knives

Noise encapsulated machine:

- open the doors.
- loosen and remove the protective plate on rear side of the granulator.

Open the cutter house door and hopper.

Remove the granule bin, screen and screen box

- read section 5.5.



**Tips!** Lock the cutter house door in open position.

With a block of wood, size 25 x 50, length 230 mm, the cutter house door can be stopped in the open position.

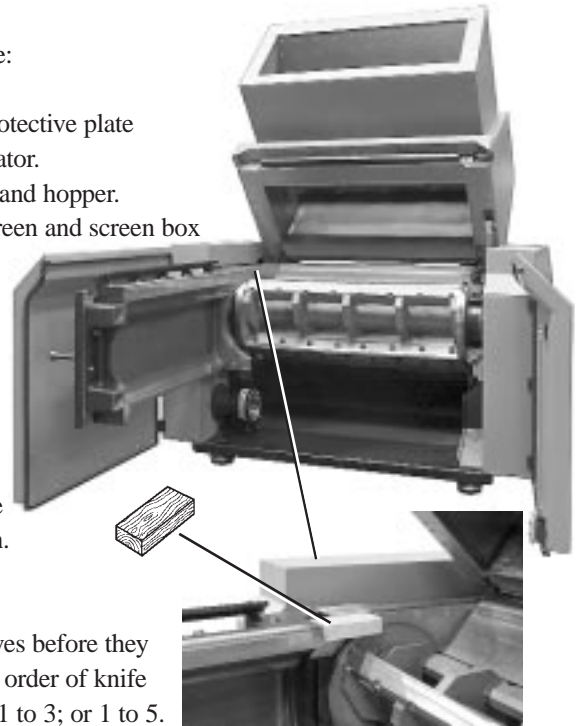

**NOTE:** Make sure that the block of wood is of good quality.

**Warning. A block which breaks during work can cause personal injury!**



## Mark the knives

Mark support rules and knives before they are removed. First mark the order of knife position on the cutter with: 1 to 3; or 1 to 5.

Then mark the position of the support rules on the rotating knives with right, left and order on the cutter.

Then mark the position of the support rules on the fixed knives.

## If the knives are removed for grinding.

Mark each knife before removing it with the position right, left and order on the cutter.

It makes the knife re-installation simpler and quicker!

## 7.1 Knife changing (continued)

### Cutter lock

The cutter lock brakes the cutter belt pulley automatically when the hopper opens.

The cutter lock can be released manually by a control lever, during the moment the cutter need to be turned.

The control lever for is located in the space between the left side of the cutter housing and the transmission cover.



**NOTE:** Let the cutter lock brake the granulator cutter all the time the knife changing takes.

Release the cutter lock only the short time and on the moment the cutter need to be manually turned.

### Screws and nuts with red marking



**IMPORTANT!** All screws and nuts which are marked with red color, are screws and nuts which have fixed settings.

These settings are made during the manufacturing of the granulator, and should under no circumstances be changed.

If the any screw or nut marked with red color change position, by using of tools the granulator will loose important basic settings.



**NOTE:** If any color marking is broken or have changed positions, all of Conair's responsibility and guarantee become invalid.

### Removing of knives

#### Removing of rotating knives



**NOTE:** The cutter lock effectively brakes the cutter belt pulley, but for safety reasons, lock the cutter against the cutter housing using a strong block of wood to avoid self-rotation when screws are loosened with torque.

The cutter, cutter shaft, cutter belt pulley and poss. flywheel is together a big and very heavy unit. The energy of a cutter in motion is very big when it is in motion. The risk and danger of injury to fingers and hands is very great.



**NOTE:** In the moment the cutters must be turned manually, do this with very great care! The knives are heavy and sharp and could cause personal injury.



**NOTE:** Never try to stop a cutter by hand when it is moving, even if the moving is slowly.

## 7.1 Knife changing (continued)

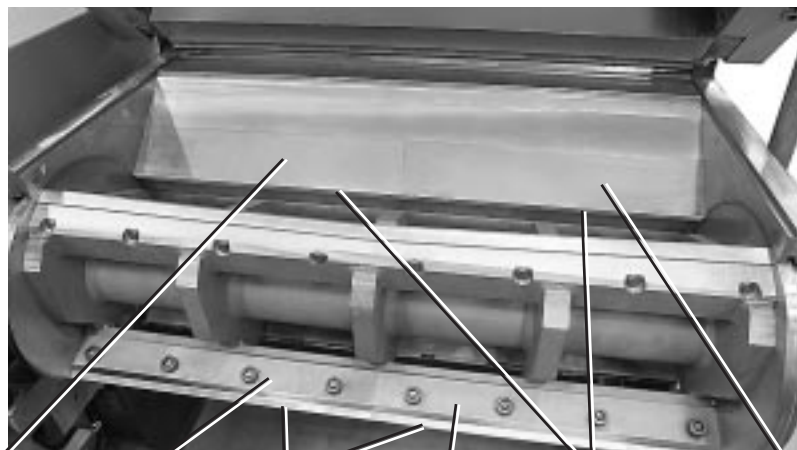

Support rule Support rule Rotating knife pair Support rule Fixed knife pair no.1 (rear) Support rule

### 3-blade cutter and 5-blade cutter

- 1 Undo and remove the socket cap screws which fasten the support rules and the rotating knives (hex 17 mm). The knives and support rules are now loose.



**NOTE:** Hold both the support rule and the knife, when the last screw for the knife is undone and removed.



**Remember!** Mark the support rule and the knife.



**NOTE:** Be careful! If the cutter lock is released the cutter auto-rotates when the centre of gravity becomes unstable.

- 2 Lift out the support rules and the rotating knives.
- 3 Clean the knife positions where the knives were located.

### Removing of fixed knives

Each fixed knife consists of one pair of support rules and one knife pair.



**NOTE:** Depending on the model of the cutter housing the granulator can be equipped with five different fixed knives.



**Remember!** Screws and nuts marked with red color must never change position.

Fixed knife pair no. 1 (rear)

- 1 Noise encapsulated machine, loosen and remove the protective plate on rear side of the granulator.
- 2 Undo and remove the socket cap screws which fasten the support rules and the fixed knife pair (hex 17 mm).

## 7.1 Knife changing (continued)

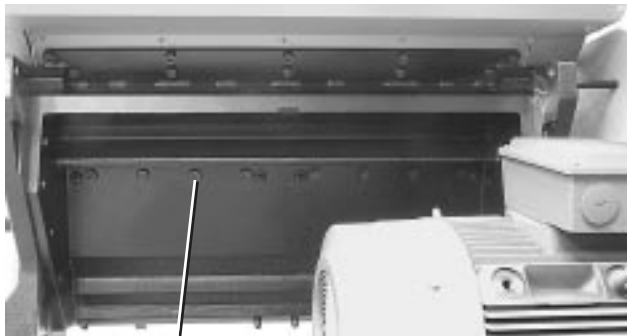

Socket cap screws to fixed knife no. 1

The socket cap screws which fasten the support rules and the fixed knife pair, are undone from rear side of the cutter housing.

- 3 Mark and lift out the support rules to the fixed knife pair.
- 4 Mark and lift out the fixed knife pair.
- 5 Clean the knife positions where the knives were located.

### Fixed knife no. 2 (front)

- 1 Undo and remove the socket cap screws which fasten the support rules and the fixed knife pair (hex 17 mm).

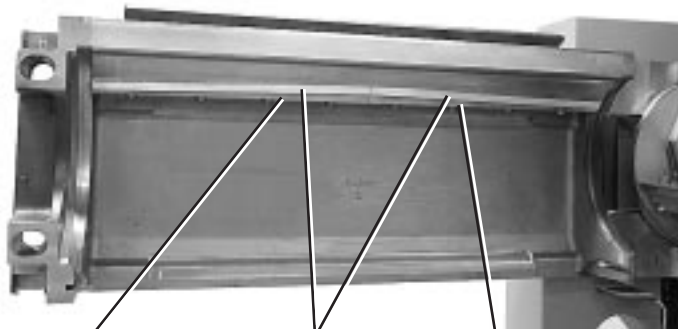

Support rule    Fixed knife pair no. 2 (front)    Support rule

The socket cap screws which fasten the support rules and the fixed knife pair, are undone from inside of the cutter house door.



**NOTE:** The fixed knife and the support rules are heavy, be careful!



**NOTE:** Hold both the support rule and the fixed knife, when undone and removing the last screw to the support rule.

## 7.1 Knife changing (continued)

- 2 Lift out and mark each support rule together with the knife to the fixed knife pair.
- 3 Clean the knife positions where the knives were located.

### Fixed knife no. 3 (rear upper, option)

- 1 Noise encapsulated machine, loosen and remove the protective plate on rear side of the granulator.
- 2 Undo and remove the socket cap screws which fasten the support rules and the fixed knife pair (hex 17 mm).  
The socket cap screws which fasten the support rules and the fixed knife pair, are undone from rear side of the cutter housing.
- 3 Mark and lift out the support rules to the fixed knife pair.
- 4 Mark and lift out the fixed knife pair.
- 5 Clean the knife positions where the knives were located.

### Fixed knife no. 4 (front upper, option)

- 1 Undo and remove the socket cap screws which fasten the support rules and the fixed knife pair.  
The socket cap screws which fasten the support rules and the fixed knife pair, are undone from outside of the cutter house door.



NOTE: The fixed knife and the support rules are heavy, be careful!

- 2 Mark and lift out the support rules.
- 3 Mark and lift out the fixed knife pair.
- 4 Clean the knife positions where the knives were located.

# 7.1 Knife changing (continued)

## Fixed knife no. 5 (lower, option)

**1** Undo and remove the socket cap screws which fasten the support rules and the fixed knife pair (hex 17 mm).

The socket cap screws which fasten the support rules and the fixed knife pair, are undone from underneath the front side of the cutter housing.

**2** Mark and lift out the support rules to the fixed knife pair.

**3** Mark and lift out the fixed knife pair.

**4** Clean the knife positions where the knives were located.

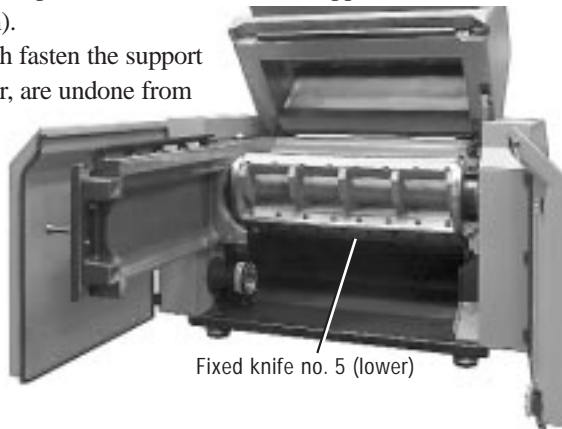

Fixed knife no. 5 (lower)



**NOTE:** Hold both the support rule and the fixed knife, when the last screw for the support rule is undone and removed.



**NOTE:** The fixed knife and the support rules are heavy, be careful!



**NOTE:** All knives which are to be installed should be pre-set before installing. Both fixed and rotating knives!



**NOTE:** Each time the set of knives is changed, the screws and washers which fasten the knives must be replaced by new ones.



**NOTE:** Every second time re-sharpened knives are installed, the screws and washers which fasten the knives must be replaced by new ones.

## Installing of knives

The knife attachments for both fixed and rotating knives must have been properly cleaned.

The screws which retain the knives are of high strength class.

Only screws supplied by Conair may be used for installing knives.

It is very important that the knives are torqued to correct tightening torque.

To install the fixed and rotating knives a strong torque wrench is needed.

The knives tightening torque

Front and rear fixed knife . . . . .	600 Nm
Rotating knives . . . . .	600 Nm

## Pre-setting of knives



**NOTE:** The knives must be sharpened before pre-setting.

## Pre-setting fixture

In the delivery of the CW granulators, are two pre-setting fixtures of the compact model included. One pre-setting fixture to rotating knives and one fixture to fixed knives. Furthermore one 8 mm hex wrench and a 0.20 mm feeler gauge are included, for pre-setting of all knives in the granulator. The pre-setting fixtures makes the knife installation simpler and quicker. The pre-setting fixtures are calibrated against the fixed set positions in the granulator. The fixtures makes it simply and quick to pre-set the knives to a 0.20 - 0.50 mm knife clearance.

The pre-setting fixture of compact model for rotating knives is marked "R"

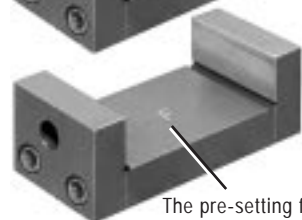

The pre-setting fixture of compact model for fixed knives is marked "F"

## 7.1 Knife changing (continued)

Pre-setting fixtures are available in two different models.

A bigger fixture is available as an option art.no. 3-45082. The bigger fixture gives a very exactly pre-setting of clearance for the rotating knives before installing.

### Pre-setting

- 1 Screw the adjustment screws in somewhat (into the knife) on the knife.
- 2 Place the pre-setting fixture right in front of one of the knife adjusting screws, with the knife edge backward and upwards.
- 3 Put an 0.20 mm feeler gauge between the knife edge and the rear of the fixture.
- 4 Use a hex wrench (8 mm) and unscrew the adjustment screws until the feeler gauge begins to bind.
- 5 Place the pre-setting fixture right in front of the knife second adjusting screw, with the knife edge backward and upwards.
- 6 Put an 0.20 mm feeler gauge between the knife edge and the rear of the fixture.
- 7 Use a hex wrench (8 mm) and unscrew the adjustment screws until the feeler gauge begins to bind.
- 8 Then the pre-setting is completed and the knife can be installed in the granulator.



### Installing of pre-set knives



**NOTE:** All knife positions must be properly cleaned and free from oil and grease!



Tips for installation of pre-set knives:  
Mark each knife, with a felt-tip pen when each task is carried out:

-  = The knife clearance is correctly set in the knife fixture.
-  = The knife screws are torqued to the correct torque.
-  = The knife clearance has been rechecked and is correct.

## 7.1 Knife changing (continued)

First install the fixed knives

First install fixed knife no. 1; or fixed knife no. 3 (rear fixed knife)

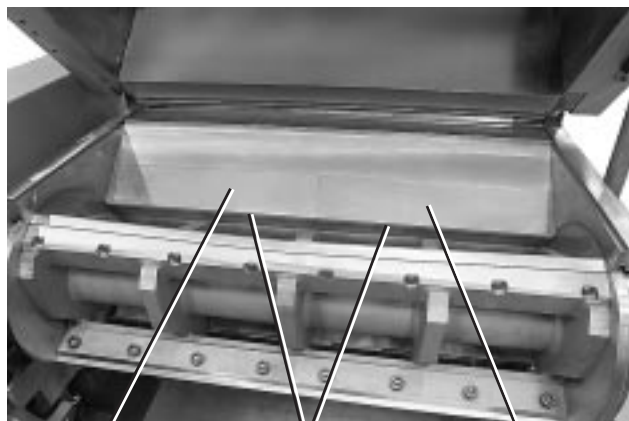

Support rule      Fixed knife pair no.3 (rear)      Support rule

**1** Install the knife pair in the knife position.

**2** Install the support rules.

**3** Fit the socket cap screws so that the support rules lightly support the knife pair. The socket cap screws are fitted from the rear of the cutter housing.

**4** Fasten the knife with the socket cap screws and the support rules and tighten with an alternated increased torque to 200 Nm (hex 17 mm).

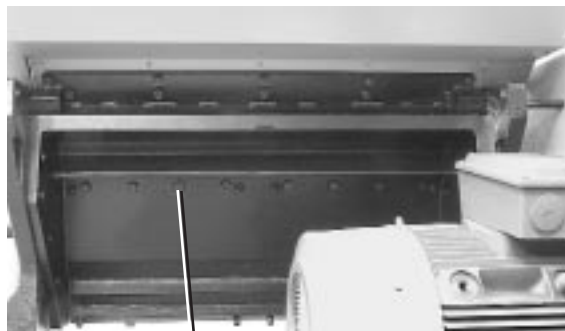

Socket cap screws to fixed knife no. 1

**5**  **NOTE:** Use a plastic or rubber mallet and knock/hammer the knives hardly in against the rear of the knife position.



**6** Fasten the knife with the socket cap screws and the support rules furthermore with an alternated increased torque to 400 Nm.



**NOTE:** Knock/hammer between the alternately increasing tightening torque with the plastic or rubber mallet, so that the knives firmly goes in to the rear of the knife position.

**7** Fasten the knife with the socket cap screws and the support rules furthermore with an alternated increased torque to 600 Nm.

## 7.1 Knife changing (continued)

### Then install fixed knife no. 2 (front)

**1** Install one support rule together with one knife at a time.

Fit the socket cap screws so that the support rule lightly hold the knife.

The socket cap screws are fitted from the inside of the cutter house door.

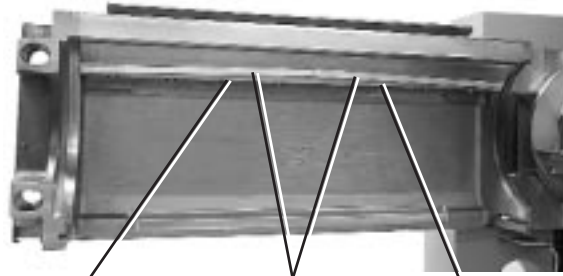

Support rule Fixed knife pair no. 2 (front) Support rule



**2 Tips!** Lock the cutter house door in open position.

Use a block of wood, size 25 x 50, length 230 mm.

It could otherwise be difficult to fasten the socket cap screws to the front fixed knife to the correct tightening torque. Because the tightening makes in the same direction as the door is closed.

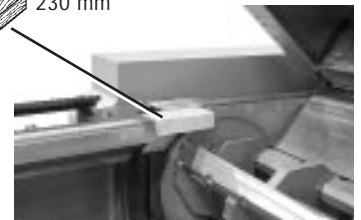
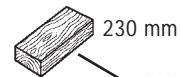

**3** Fasten the knife with the socket cap screws and the support rules and tighten with an alternated increased torque to 100 Nm.

**4**  **NOTE:** Use a plastic or rubber mallet and knock/hammer both the knives and the support rules hardly in and up against the rear of the knife position.



**5** Fasten the knife with the socket cap screws and the support rules further with an alternated increased torque to 200 Nm.



**NOTE!** Knock/hammer between the alternately increasing tightening torque with the plastic or rubber mallet, so that both the knives and the support rules firmly goes up and in to the rear of the knife position.

**6** Fasten the knife with the socket cap screws and the support rules furthermore with an alternated increased torque to 400 Nm.



**NOTE!** Knock/hammer between the alternately increasing tightening torque with the plastic or rubber mallet, so that both the knives and the support rules firmly goes up and in to the rear of the knife position.

## 7.1 Knife changing (continued)

- 7 Fasten the knife with the socket cap screws and the support rules furthermore with an alternated increased torque to 600 Nm.

### Then install fixed knife no. 4 (option)

The fourth fixed knife is installed in exactly the same way as the front fixed knife, the front fixed knife no. 2. Read and follow the above description.

### Install the fifth fixed knife (option)

- 1 Install one support rule together with one knife at a time.

Fit the socket cap screws so that the support rule lightly hold the knife.

The socket cap screws which fasten the support rules and the fixed knife pair, are fitted from underneath the front of the cutter housing.

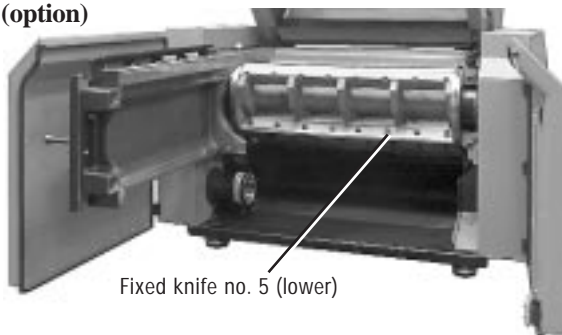

- 2 Fasten the knife with the socket cap screws and the support rules and tighten with an alternated increased torque to 200 Nm.

- 3  **NOTE:** Use a plastic or rubber mallet and knock/hammer the knives hardly down and in against the rear of the knife position.



- 4 Fasten the knife with the socket cap screws and the support rules furthermore with an alternated increased torque to 400 Nm.

-  **NOTE:** Knock/hammer between the alternately increasing tightening torque with the plastic or rubber mallet, so that the knives firmly goes down and in to the rear of the knife position.

- 5 Fasten the knife with the socket cap screws and the support rules furthermore with an alternated increased torque to 600 Nm.

# 7.1 Knife changing (continued)

## Installing of rotating knives



**NOTE:** Make sure that there never are any granulate or plastic residue on the floor during changing of knives.

**WARNING!** Granulate and plastic residue on the floor can cause risk of slipping!

If anyone slips or falls during changing of knives, or handling of knives, it can cause serious personal injury.



**WARNING! NOTE:** The granulator is equipped with a cutter lock, but when the cutter lock is released the cutter auto-rotates, at installing of rotating knives.

The cutter auto-rotates when the center of gravity becomes unstable when installing knives.

So therefore be careful when changing knives, so as not to injure fingers or hands.



**OBSERVE! Never resort to help when installing rotating knives.**

**Always carry out knife changing alone, so as to minimize the risk of injury to fingers or hands.**



The cutter lock brakes the cutter belt pulley, but for safety reasons, when screws on knives are installed with tightening torque, always secure the cutter to the cutter housing using a strong block of wood, to avoid that the brake can glide.



Be careful when handling the knives, they are sharp and can cause personal injury.

Always use protective gloves when changing knives!

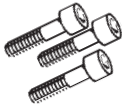

Each time the set of knives is changed, the screws which hold the knives must be replaced by new ones.

Every second time re-sharpened knives are installed, the screws which hold the knives must be replaced by new ones.



When installing rotating knives, always install all the rotating knives on the cutter, so that the cutter will be balanced.

**NOTE:** The knife positions must be properly cleaned and free from grease!

## 7.1 Knife changing (continued)

- 1 Install one rotating knife pair at a time, in the knife positions on the cutter, with support rules and socket cap screws, so that the support rules lightly support the rotating knife pair.

Use a plastic or rubber mallet and knock/hammer the knife pair in against the rear of the knife position, so that they firmly goes in against the rear of the knife position.



Support rule    Rotating knife pair    Support rule

- 2 Fasten the rotating knives with the socket cap screws and the support rules at a tightening torque of about 50 Nm.
- 3 Check with care, that the rotating knife pair can pass all the fixed knives freely.

**If the rotating knife pair can pass all the fixed knives freely.**

Continue to install the remaining knife pairs according to steps 1 - 3 as per above.

**If the rotating knife pair cannot pass all the fixed knives freely.**

Use a plastic or rubber mallet and knock/hammer the knife pair in against the rear of the knife position.

- Then check again with care that the rotating knife pair can pass all the fixed knives freely.

If the rotating knife pair cannot pass all the fixed knives freely.

Remove the fixed knife pair which the rotating knife pair cannot pass freely.

Check and make a new pre-setting of the fixed knife pair. Then re-install the fixed knife pair.

Then continue from step 3 above.

(continued)

## 7.1 Knife changing (continued)

- 4 Fasten all the rotating knife pairs with the socket cap screws and the support rules with an alternated increased torque to 200 Nm.

- 5  **NOTE:** Use a plastic or rubber mallet and knock/hammer the knives hardy in against the rear of the knife position.



- 6 Fasten the knife with the socket cap screws and the support rules further with an alternated increased torque to 400 Nm.

- 7 Fasten the knife with the socket cap screws and the support rules furthermore with an alternated increased torque to 600 Nm.

### Check the knife installation

- 8 Re-check the tightening torque for all the fixed knife pairs, 600 Nm.

- 9 Then re-check the knife clearance of all rotating knife pairs against the fixed knife no. 1 (rear).

Use a feeler gauge, the clearance should be 0.20 - 0.50 mm.

### If the knife clearance of any rotating knife pair is incorrect

Undo the screws to the knife pair, then knock/hammer the knife pair in against the rear of the knife position, so that the knives firmly goes in to the rear of the knife position.

Then continue from step 3 as per above for this knife pair.

- 10 Re-check the tightening torque for all the rotating knife pairs.  
If the tightening torque of any screw to any of the rotating knife pairs is changed, the knife clearance for this knife pair must also be re-checked again.

**NOTE:** Sign in the service schedule when knife changing is completed.

### 4 - 8 hours after knife changing

- 1 Re-check the tightening torque for all the rotating knife pairs.
- 2 If the tightening torque of any screw to any of the rotating knife pairs is changed, the knife clearance for this knife pair must also be re-checked again.

**NOTE:** Sign in the service schedule when the re-check after knife installation is completed.



**NOTE:** Knock/hammer between the alternately increasing tightening torque with the plastic or rubber mallet, so that the knives firmly goes in to the rear of the knife position.

## 7.2 Grinding of knives

**NOTE:** The instruction for knife grinding refers to 3 different knives.

Grinding of:

- rotating knives.
- rear fixed knife no. 1, front fixed knife no. 2, fourth and fifth fixed knife.
- third fixed knife.

All knives must be ground precisely, to give the correct cutting and relief angles. Otherwise the granulator loses its efficiency.



Be careful when you handle knives!



Knives are sharp and can cause personal injury.

Only grind the marked surfaces, and respect the specified dimensions!



**NOTE:** Conair knives are made from hardened steel.

Hardened steel knives are brittle and can crack if they are dropped or are handled carelessly.



It requires skill to grind knives, so please let a skilled, experienced craftsman grind the knives.

### Cool the knives when you grind them

Heat is developed during grinding, so the knives must be cooled when they are being ground. Knives which are exposed to excessive heat, are burned or blued, lose their hardness, strength and durability.

Knives which are burned, blued, or exposed to excessive heat, can not be repaired by grinding away the blued or burned color.

Blued or burned knives are useless.

### Grinding fixture (option).

For CW granulator models use the Conair grinding fixture art.no. 3-45652.

Using the grinding fixture and a surface grinder with magnetic table, all the knives in the granulator can be ground with the precise, correct cutting and relief angles.

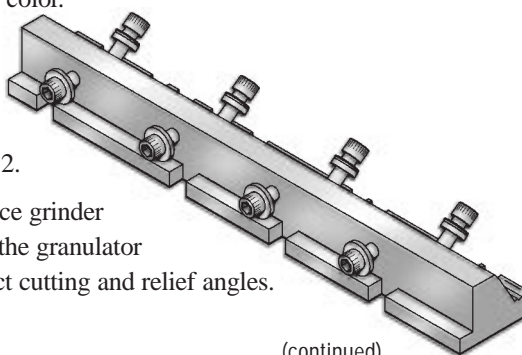

(continued)

## 7.2 Grinding of knives (continued)

### First grind the relief angle

Grind the relief angle first. Grind the relief angle until there are no uneven spots on the knife edge.

Cool the knives when you grind them, grind slowly and make sure that no heat is generated.



**NOTE:** If a knife is blued or burned, it is useless.

### Then grind the cutting angle on the knife edge

When the relief angle has been ground and there are no uneven spots on the knife edge, you can grind the cutting angle on the knife edge. The knife is "sharpened" and is given a knife edge in new, fresh steel.

Cool the knives when you grind them, grind slowly and make sure that no heat is generated.



**NOTE:** If the knife edge is blued or burned, the knife is useless.

### Grinding of rotating knives

The rotating knives consist of a set of several knife pairs. Keep the complete set of knives together, as one unit.

### Balancing

The cutter in the granulator is balanced during manufacture. To retain balance in the cutter, all the rotating knives must have exactly the same weight.

All rotating knives in a set of knives must therefore be ground exactly the same.

After grinding, the knives must all have the same weight, to within a gram.

Follow the instruction and use the grinding fixture and surface grinder with magnetic table, to make all the rotating knives exactly the same weight, cutting and relief angle.

### Grinding

Grind the worst knife first. The adjusting screws on the knives do not need to be removed. The grinding fixture has cutouts for the adjusting screws.

Grind the relief angle on the worst knife first

Relief angle 55°.

- Install the knife in the fixture as shown in the illustration, with the knife's rear lower edge in the outer groove on the grinding fixture.
- Fix the knife, use the screws and the spherical washers which belong to the grinding fixture.

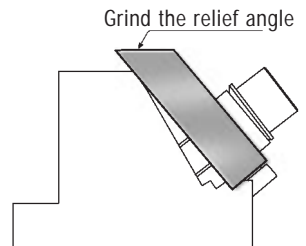

(continued)

## 7.2 Grinding of knives (continued)

- Grind the relief angle until the knife edge does not have any irregularities.
- **NOTE:** Retain the settings on the surface grinder and grind the relief angles on all the rotating knives exactly the same.



Grind the cutting angle

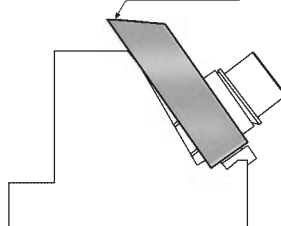

### Grind the cutting angle on the knives

Cutting angle 50°.

- Install the knife in the fixture as shown in the illustration, with the knife's rear lower edge in the middle groove on the grinding fixture.
- Fix the knife, use the screws and the spherical washers which belongs to the grinding fixture.
- Grind the cutting angle until the knife edge is exactly 4 mm wide.

- **NOTE:** Retain the settings on the surface grinder and grind the cutting angles on all the rotating knives exactly the same.

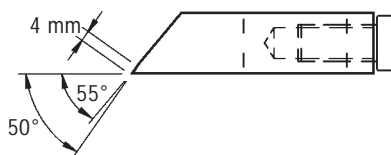

### Minimum knife dimensions

- The knives can be ground down to the dimensions in the adjacent illustration. After that, the knives are used up and must be replaced by new ones.

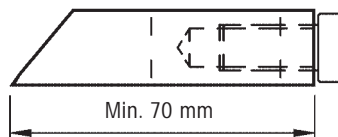

### Grinding of rear fixed knife no. 1, front fixed knife no. 2, the fourth and fifth fixed knife.

The rear fixed knife no. 1, the front fixed knife no. 2, the knife no. 4 and no. 5 are identical.

The knives have two cutting sides and are reversible.

Each knife can be ground with two cutting sides.

This means that the knives can be turned over and two cutting sides can be used before they have to be re-ground.

The front and rear knives do not need to be ground to the same dimensions.

Follow the instruction, use grinding fixture and surface grinder with magnetic table. The grinding fixture gives the fixed knives precise and correct cutting angles.

(continued)

## 7.2 Grinding of knives (continued)

### Grinding

Grind one knife at a time.

Cutting angle  $90^\circ$ .

- Install the knife in the fixture as shown in the illustration.
- Fix the knife, use the screws and the flat hardened washers which belong to the grinding fixture.
- Grind two cutting angles until the knife edges do not have any irregularities.

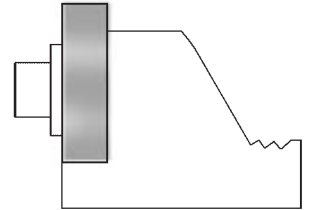

### Minimum knife dimensions

- The knives can be ground down to the dimensions in the adjacent illustration. After that, the knives are used up and must be replaced by new ones.

Grind the cutting angle  $90^\circ$

Grind the cutting angle  $90^\circ$

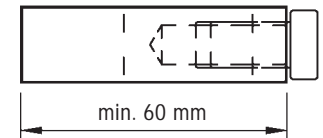
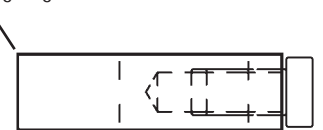

(continued)

## 7.2 Grinding of knives (continued)

### Grinding the third fixed knife

The third fixed knife is ground on the same side of the grinding fixture as the rotating knives.

Follow the instruction and use the grinding fixture and surface grinder with magnetic table. The grinding fixture gives the third fixed knife the precise and correct cutting angle.

### Grinding

Grind the cutting angle on the knife

Cutting angle 60°.

- Install the knife in the fixture as shown in the illustration, with the knife's rear lower edge in the inner groove on the grinding fixture.
- Fix the knife, use the screws and the flat hardened washers which belongs to the grinding fixture.
- Grind the cutting angle until the knife edge does not have any irregularities.

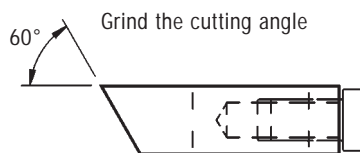
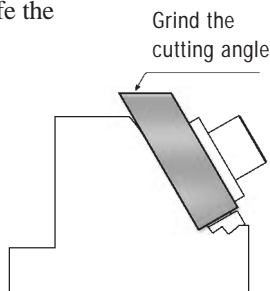

### Minimum knife dimensions

- The knife can be ground down to the dimensions in the adjacent illustration. After that, the knife is used up and must be replaced by a new one.

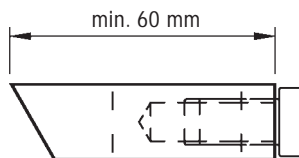

## 7.3 Transmission

The machine is driven by 3 to 6 pcs drive-belts depending on granulator size and motor size.

20 -30 hours after installation and operation at normal load of the granulator, the tension and condition of the drive-belts must be checked at the first time.

Then the drive belts should be inspected every 3 months. Check the condition and that the drive belts are intact, undamaged and without any cracks.

Check the drive-belt tension every 6 months.

### Inspection of the drive-belts

To check the drive belts

Stop the granulator according to section “6.1 Stop”.

- Press the ”Stop” button.
- Turn the main switch to position “0” Off.
- Unplug the granulator connector from the electric power supply
- Press the emergency stop knob.
- Open the cutter house door.
- Open the hopper.
- Undo and remove the protective plate on left side of the granulator.



### Check the drive belts

- Rotate the drive-belts one complete turn.  
Check that all drive belts are intact, undamaged and without any cracks.



**WARNING!** Pinch risk between pulleys and drive-belts.

- Re-place the protective plate on left side of the granulator.



(continued)

## 7.3 Transmission (continued)

### Inspection and adjustment of the drive belt tension

To check the drive belt tension

Stop the granulator according to section “6.1 Stop”.

- Press the “Stop”-button.
- Turn the main switch to position “0” Off.
- Unplug the granulator connector from the electric power supply
- Press the emergency stop knob.
- Open the cutter house door.
- Open the hopper.
- Undo and remove the protective plate on left side of the granulator.
- Rotate the drive-belts one complete turn.



**WARNING! Pinch risk between pulleys and drive-belts.**

- Check the motor size, kilowatt (kW) and hertz (Hz) in the wiring diagram.
- Check the belt tension by loading each drive-belt with 75 N in the mid-way between the cutter and motor pulleys.

Measure the deflection in mm. at the same time.

- The table below shows how much it should be possible to deflect the drive belts.

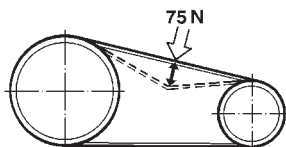

Motor 50 Hz	18.5/22 kW	30/37 kW	45/55 kW
It should by a load of 75 N be possible to deflect the drive-belts max:			
When installing a new belt	15 mm	14 mm	15 mm
When re-check (6 months)	19 mm	19 mm	19 mm
Motor 60 Hz	18.5/22 kW	30/37 kW	45/55 kW
It should by a load of 75 N be possible to deflect the drive-belts max:			
When installing a new belt	18 mm	17 mm	16 mm
When re-check (6 months)	23 mm	23 mm	20 mm

### Adjustment of the drive belts

The drive belt tension is adjusted by the angle of the motor mounting bracket. The angle of the motor mounting bracket regulate the distance between motor and cutter pulley.

- On a soundproofed machine, undo and remove the protective cover at rear of the granulator and the protective plate on right side of the granulator.
- Unscrew the screws “G” about 1/2 a turn.
- Then adjust the angle of the motor mounting bracket using the adjusting and counter nuts “H” 4 pcs.

(continued)

## 7.3 Transmission (continued)

Make sure that the motor mounting bracket is in horizontal level after adjusting. Check using a spirit level.

If the motor mounting bracket is not horizontal, the belt pulleys do not align. The drive belts will get wear sideways, with risk of the drive belts can break or jump off.

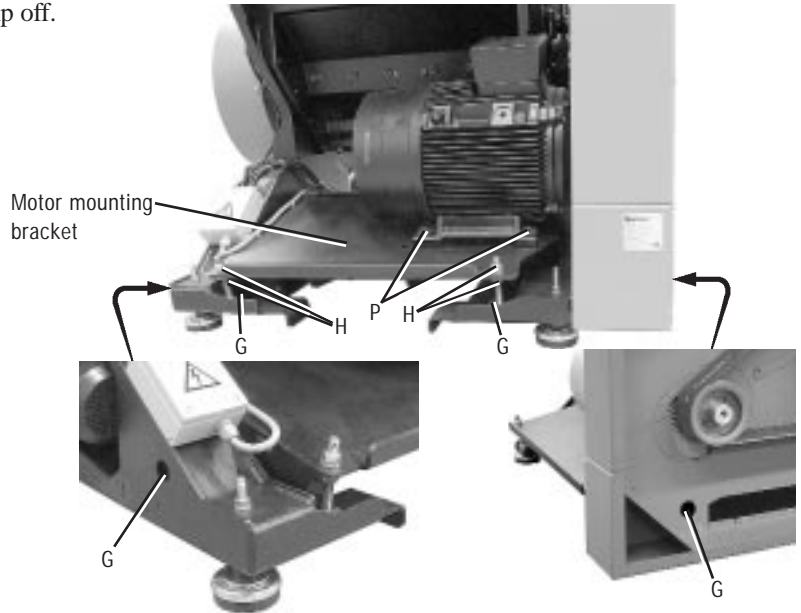

- When the drive belts have correct tension. Lock the setting of the motor mounting bracket.  
Lock the adjusting nuts with the counter nuts. Hold the settings of the adjusting nuts with a fixed open-ended spanner and tighten the counter nut against the adjusting nut to a torque of 300 Nm.
- Fasten the screws “G” to a torque of 300 Nm.
- After adjusting the drive belts tension, check the screws “P” (4 pcs.) which holds the granulator motor to the motor mounting bracket.

Motor power	screw	tightening torque
18.5 and 22.0 kW	M12	80 Nm.
30.0; 37.0 and 45.0 kW	M16	200 Nm.
55.0 kW	M20	400 Nm.



**NOTE:** Note belt tension adjustments in the machine service schedule.



**NOTE:** Sign the service schedule, when the re-check is completed.

- Re-place the protective plate on the left side of the granulator.
- On a machine with soundproofing, re-install the protective cover at rear of the granulator and the protective plate on right side of the granulator.
- If the drive belts tension is adjusted or if the drive belts are re-placed, the belt tension and condition should be re-checked after 20 - 30 hours at normal load. Check also that the settings of the adjusting nuts are locked with the counter nuts.

## 7.4 Lubrication

The granulator has enclosed grooved bearings lubricated for life and can not be lubricated later on.

For any repair or maintenance please contact the local Conair distributor or the Conair head office.

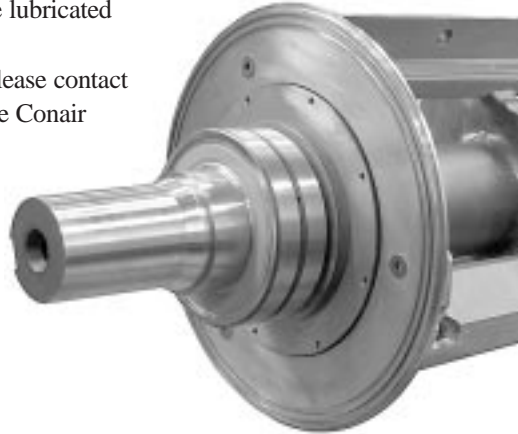

## 7.5 Cutter lock

The CW granulator is equipped with a cutter lock.  
The cutter lock brakes the cutter belt pulley with aid of a mechanical brake.

**NOTE:** The cutter lock is activated automatically when the hopper opens.

### **The cutter lock can be opened manually**

The cutter lock can be opened manually during cleaning, service and maintenance of the granulator.

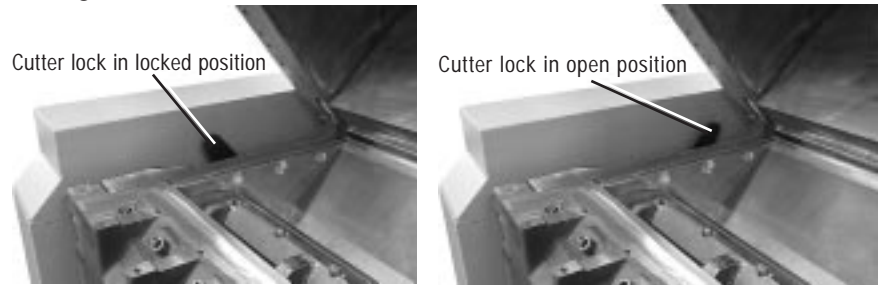

### **Inspection**

Check the function of the cutter lock every three months.

Check that the cutter lock is automatically activated when the hopper opens and that the cutter brakes.

If the cutter lock not brakes the cutter, contact Conair's service department in order to change the rubber damper to the cutter lock.

Changing the rubber damper

Changing the rubber damper is not a simple matter.

To change the rubber damper must:

- The side plate on left side of the granulator be removed.
- The upper side cover on left side of the granulator be removed.
- The cutter belt pulley be removed:
  - reduce the drive belts tension
  - remove the drive belts
  - remove the cutter belt pulley by using a puller and a lifting device

Then the rubber damper to the cutter lock can be changed.

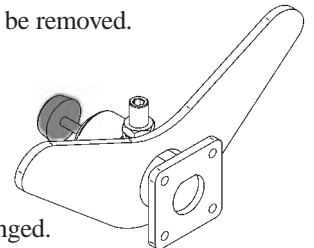

## Spare Parts List

---

8.1	Cutter housing	8-3
8.2	Cutter 3-blade and 5-blade	8-5
8.3	Knives	8-6
8.4	Transmission 380-420 Volt/50Hz	8-7
8.5	Transmission 60Hz	8-8
8.6	Screen and screen box	8-9
8.7	Granule bin	8-10
8.8	Hopper front	8-11
8.9	Inlet, sound trap, flap	8-12
8.10	Outfeed, blower F25	8-13
8.11	Outfeed, blower F40	8-14
8.12	Body	8-15
8.13	Jack	8-16
8.14	Cutter lock	8-17
8.15	Enclosure	8-18
8.16	Electrical components	8-19
8.17	Security	8-20
8.18	Flywheel	8-21
8.19	Cyclone and dust filter	8-22
8.20	Tools and fixtures	8-23

### Ordering spare parts

Only use spare parts from Conair when replacing machine parts.

When ordering, the following should be specified:

- Machine designation, as specified on the machine plate.
- Serial number, as specified on the machine plate.
- Part number, as specified in the spare parts list.
- Quantity, as specified in this spare parts list.

# 8.1 Cutter Housing

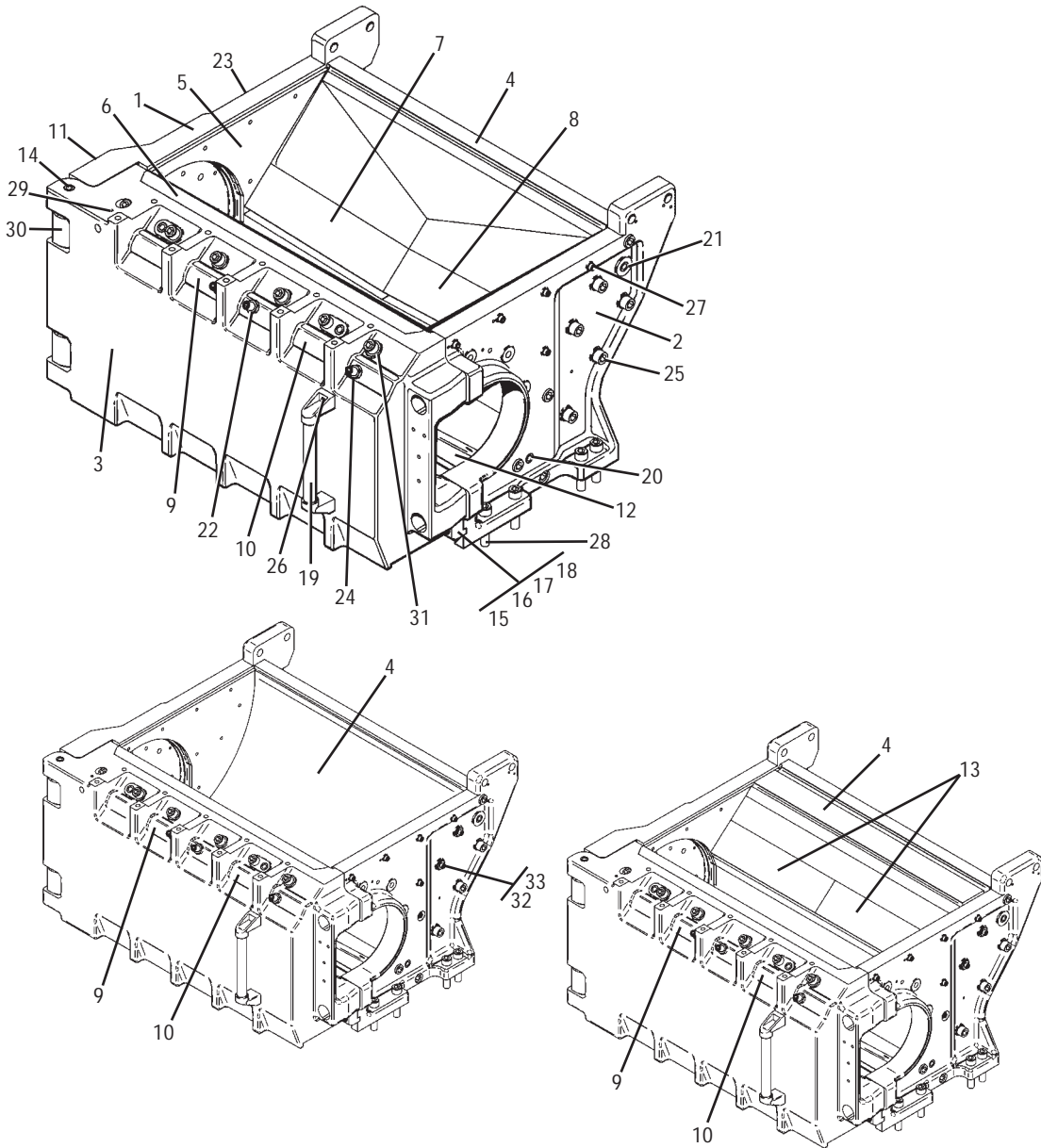

(continued)

## 8.1 Cutter Housing (continued)

Pos	Qty.									Art. no.	Description	Note
										3-45010	1824 Cutter housing 1-st 2-nd 5-th	Basic version of cutter house
										3-45088	1824 Cutter housing 5-th 2-nd	Cutter house for bulky items
										3-45089	1824 Cutter housing 3-rd 2-nd 5-th	Cutter house for precutting
										3-45030	1836 Cutter housing 1-st 2-nd 5-th	Basic version of cutter house
										3-45038	1836 Cutter housing 5-th 2-nd	Cutter house for bulky items
										3-45045	1836 Cutter housing 3-rd 2-nd 5-th	Cutter house for precutting
										3-45046	1848 Cutter housing 1-st 2-nd 5-th	Basic version of cutter house
										3-45073	1848 Cutter housing 5-th 2-nd	Cutter house for bulky items
										3-45074	1848 Cutter housing 3-rd 2-nd 5-th	Cutter house for precutting
1	1	1	1	1	1	1	1	1	1	1-45104	Side left	
2	1	1	1	1	1	1	1	1	1	1-45105	Side right	
3	1	1	1	-	-	-	-	-	-	1-45100	Front side	
	-	-	-	1	1	1	-	-	-	1-45106	- " -	
	-	-	-	-	-	-	1	1	1	1-45110	- " -	
4	1	-	-	-	-	-	-	-	-	1-45101	Back side	
	-	1	-	-	-	-	-	-	-	1-45103	- " -	
	-	-	1	-	-	-	-	-	-	1-45102	- " -	
	-	-	-	1	-	-	-	-	-	1-45107	- " -	
	-	-	-	-	1	-	-	-	-	1-45109	- " -	
	-	-	-	-	-	1	-	-	-	1-45108	- " -	
	-	-	-	-	-	-	1	-	-	1-45111	- " -	
	-	-	-	-	-	-	-	1	-	1-45113	- " -	
	-	-	-	-	-	-	-	-	1	1-45112	- " -	
5	2	2	-	2	-	2	2	-	2	2-45117	Side, inner	
	-	-	2	-	2	-	2	-	-	2-45174	- " -	
6	1	1	1	-	-	-	-	-	-	1-45686	Holder	
	-	-	-	1	1	1	-	-	-	1-45118	- " -	
	-	-	-	-	-	-	1	1	1	1-45424	- " -	
7	1	-	-	-	-	-	-	-	-	2-45683	Support rule, left	1-st
	-	-	-	1	-	-	-	-	-	2-45138	- " -	1-st
	-	-	-	-	-	-	1	-	-	2-45435	- " -	1-st
8	1	-	-	-	-	-	-	-	-	2-45684	Support rule, right	1-st
	-	-	-	1	-	-	-	-	-	2-45139	- " -	1-st
	-	-	-	-	-	-	1	-	-	2-45436	- " -	1-st
9	1	1	1	-	-	-	-	-	-	2-45681	Support rule, left	2-nd
	-	-	-	1	1	1	-	-	-	2-45140	- " -	2-nd
	-	-	-	-	-	-	1	1	1	2-45433	- " -	2-nd
10	1	1	1	-	-	-	-	-	-	2-45682	Support rule, right	2-nd
	-	-	-	1	1	1	-	-	-	2-45141	- " -	2-nd
	-	-	-	-	-	-	1	1	1	2-45434	- " -	2-nd
11	1	1	1	-	-	-	-	-	-	2-45679	Support rule, left	5-th
	-	-	-	1	1	1	-	-	-	2-45142	- " -	5-th
	-	-	-	-	-	-	1	1	1	2-45431	- " -	5-th
12	1	1	1	-	-	-	-	-	-	2-45680	Support rule, right	5-th
	-	-	-	1	1	1	-	-	-	2-45143	- " -	5-th
	-	-	-	-	-	-	1	1	1	2-45432	- " -	5-th
13	-	-	2	-	-	-	-	-	-	2-45685	Support rule	3-rd
	-	-	-	-	-	2	-	-	-	2-45176	- " -	3-rd
	-	-	-	-	-	-	-	-	2	2-45439	- " -	3-rd
14	2	2	2	2	2	2	2	2	2	3-45149	Shaft, hinge	
15	1	1	1	1	1	1	1	1	1	4-45654	Guide, front side	
16	1	1	1	1	1	1	1	1	1	4-45655	Guide, side, right	
17	1	1	1	1	1	1	1	1	1	940134	Screw M16	
18	1	1	1	1	1	1	1	1	1	940566	Screw M10	
19	1	1	1	1	1	1	1	1	1	950645	Handle	
20	2	2	2	2	2	2	2	2	2	950644	Parallel pin	
21	4	4	4	4	4	4	4	4	4	950667	Parallel pin	
22	7	7	7	7	7	7	7	7	7	940392	Nut M20	
23	1	1	1	1	1	1	1	1	1	940600	Screw M20	
24	12	8	12	12	8	12	12	8	12	940862	Grub screw	
25	17	11	17	17	11	17	17	11	17	940072	Screw M20	
26	2	2	2	2	2	2	2	2	2	940097	Screw M8	
27	10	10	10	10	10	10	10	10	10	940211	Screw	
28	8	8	8	8	8	8	8	8	8	940819	Screw	
29	1	1	1	1	1	1	1	1	1	940825	Grub screw M10	
30	6	6	6	6	6	6	6	6	6	960220	Slide bearing	
31	4	4	4	6	6	6	6	6	6	940703	Screw	
32	-	6	-	-	6	-	-	6	-	940003	Screw M10	
33	-	6	-	-	6	-	-	6	-	940020	Washer	

## 8.2 Cutter 3-blade and 5-blade

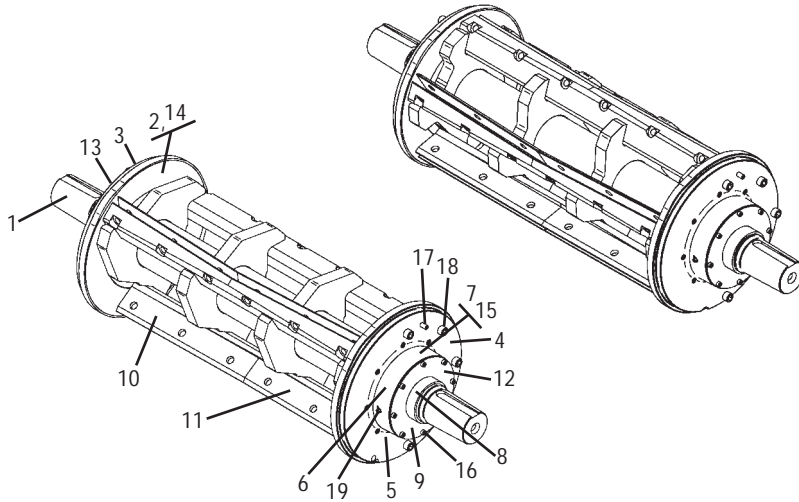

Pos	Qty.						Art. no.	Description
							3-45011	1824 Cutter 3-blade
							3-45031	1836 Cutter 3-blade
							3-45047	1848 Cutter 3-blade
							3-45081	1824 Cutter 5-blade
							3-45061	1836 Cutter 5-blade
							3-45079	1848 Cutter 5-blade
1	1	-	-	-	-	-	3-45011	Rotor 3-blade beam
	-	1	-	-	-	-	1-45124	- " -
	-	-	1	-	-	-	1-45423	- " -
	-	-	-	1	-	-	3-45081	Rotor 5-blade beam
	-	-	-	-	1	-	1-45189	- " -
	-	-	-	-	-	1	1-45454	- " -
2	2	2	2	-	-	-	2-45119	Side, rotating
	-	-	-	2	2	2	2-45190	- " -
3	1	1	1	1	1	1	1-45771	Bearing housing, left
4	1	1	1	1	1	1	1-45772	Bearing housing, right
5	2	2	2	2	2	2	3-45133	Bearing cover, inner
6	2	2	2	2	2	2	3-45134	Distance, sealing ring
7	2	2	2	2	2	2	3-45135	Bearing ring, inner
8	2	2	2	2	2	2	3-45136	Bearing ring, outer
9	2	2	2	2	2	2	3-45137	Bearing cover, outer
10	3	-	-	5	-	-	3-45524	Support rule, knife rotating, left
	-	3	-	5	-	-	3-45144	- " -
	-	-	3	-	-	5	3-45425	- " -
11	3	-	-	5	-	-	3-45525	Support rule, knife rotating, right
	-	3	-	5	-	-	3-45145	- " -
	-	-	3	-	-	5	3-45426	- " -
12	2	2	2	2	2	2	992877	Roller bearing, sealed
13	2	2	2	2	2	2	960168	Guide ring
14	12	12	12	20	20	20	940377	Screw SHS
15	2	2	2	2	2	2	960219	Sealing ring
16	32	32	32	32	32	32	940070	Screw M8
17	4	4	4	4	4	4	950668	Parallel pin
18	10	10	10	10	10	10	940674	Screw M16
19	2	2	2	2	2	2	940921	Screw SHS

## 8.3 Knives

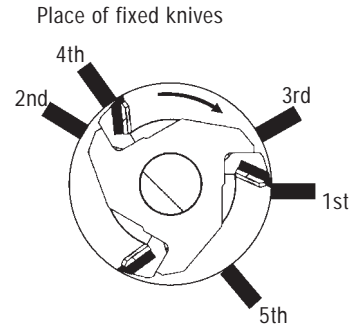
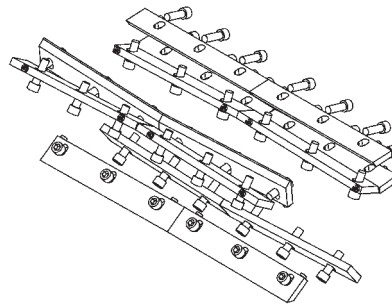

Pos	Ant.								Art. no.	Description	Note
									3-45010	1824 Cutter housing 1-st 2-nd 5-th	Basic version of cutter house
									3-45088	1824 Cutter housing 5-lh 2-nd	Cutter house for bulky items
									3-45089	1824 Cutter housing 3-rd 2-nd 5-th	Cutter house for precutting
									3-45030	1836 Cutter housing 1-st 2-nd 5-th	Basic version of cutter house
									3-45038	1836 Cutter housing 5-lh 2-nd	Cutter house for bulky items
									3-45045	1836 Cutter housing 3-rd 2-nd 5-th	Cutter house for precutting
									3-45046	1848 Cutter housing 1-st 2-nd 5-th	Basic version of cutter house
									3-45073	1848 Cutter housing 5-lh 2-nd	Cutter house for bulky items
									3-45074	1848 Cutter housing 3-rd 2-nd 5-th	Cutter house for precutting
3-Blade cutter											
1	3	3	3	-	-	-	-	-	3-45492	Rotating knife, left	
	-	-	-	3	3	3	-	-	3-45171	- " -	
	-	-	-	-	-	-	3	3	2-45182	- " -	
2	3	3	3	-	-	-	-	-	3-45494	Rotating knife, right	
	-	-	-	3	3	3	-	-	3-45172	- " -	
	-	-	-	-	-	-	3	3	2-45184	- " -	
3	12	12	12	18	18	18	24	24	940096	Screw, rotating knives, M20	High strength class *)
4	6	4	4	-	-	-	-	-	3-45490	Fixed knife	
	-	-	-	6	4	4	-	-	3-45170	- " -	
	-	-	-	-	-	-	6	4	3-45181	- " -	
5	-	-	2	-	-	-	-	-	3-45496	Fixed knife, 3-rd	
	-	-	-	-	-	2	-	-	3-45175	- " -	
	-	-	-	-	-	-	-	2	3-45187	- " -	
6	-	-	-	-	-	-	-	-	3-45458	Distance, support rule	1824
	-	-	-	-	-	-	-	-	3-45150	- " -	1836
	-	-	-	-	-	-	-	-	3-45480	- " -	1848
7	8	8	8	12	12	12	16	16	940072	Screw, fixed knife 2-nd 4-lh 5-lh, M20	High strength class *)
8	4	-	4	6	-	6	8	-	940746	Screw, fixed knife 1-st 3-rd, M20	High strength class *)
5-Blade cutter											
1	5	5	5	-	-	-	-	-	3-45492	Rotating knife, left	
	-	-	-	5	5	5	-	-	3-45171	- " -	
	-	-	-	-	-	-	5	5	2-45182	- " -	
2	5	5	5	-	-	-	-	-	3-45494	Rotating knife, right	
	-	-	-	5	5	5	-	-	3-45172	- " -	
	-	-	-	-	-	-	5	5	2-45184	- " -	
3	20	20	20	30	30	30	40	40	940096	Screw, rotating knives, M20	High strength class *)
4	6	4	4	-	-	-	-	-	3-45490	Fixed knife	
	-	-	-	6	4	4	-	-	3-45170	- " -	
	-	-	-	-	-	-	6	4	3-45181	- " -	
5	-	-	2	-	-	-	-	-	3-45496	Fixed knife, 3-rd	
	-	-	-	-	-	2	-	-	3-45175	- " -	
	-	-	-	-	-	-	-	2	3-45187	- " -	
6	-	-	-	-	-	-	-	-	3-45458	Distance, support rule	1824
	-	-	-	-	-	-	-	-	3-45150	- " -	1836
	-	-	-	-	-	-	-	-	3-45480	- " -	1848
7	8	8	8	12	12	12	16	16	940072	Screw, fixed knife 2-nd 4-lh 5-lh, M20	High strength class *)
8	4	-	4	6	-	6	8	-	940746	Screw, fixed knife 1-st 3-rd, M20	High strength class *)

\*) NOTE: Only screws, nuts, washers and bolts supplied by Conair may be used for installing knives.

If not genuine Conair screws, nuts, washers and bolts of the right length, dimension and strength class are used, Conair's responsibility and guarantee become invalid.

# 8.4 Transmission 380-420Volt/50Hz

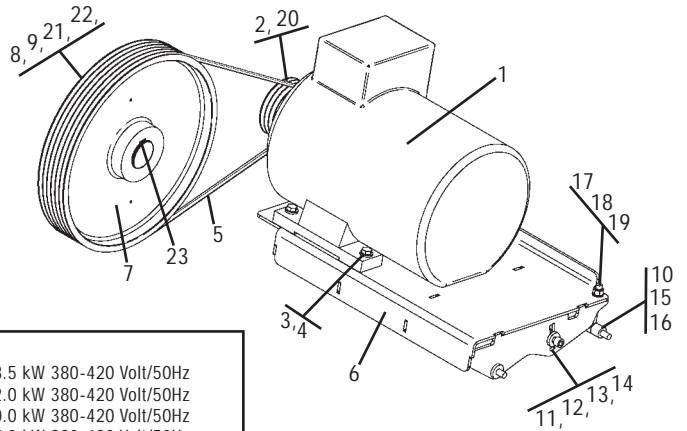

Pos	Qty.	Art. no.	Description
1	1	910019	Transmission 18.5 kW 380-420 Volt/50Hz
	-	911217	Transmission 22.0 kW 380-420 Volt/50Hz
	-	910021	Transmission 30.0 kW 380-420 Volt/50Hz
	-	910133	Transmission 37.0 kW 380-420 Volt/50Hz
	-	910106	Transmission 45.0 kW 380-420 Volt/50Hz
	-	910113	Transmission 55.0 kW 380-420 Volt/50Hz
2	1	930248	Motor 18.5 kW 380-420 Volt/50Hz 1500 rpm
	-	930265	Motor 22.0 kW 380-420 Volt/50Hz 1500 rpm
	-	930266	Motor 30.0 kW 380-420 Volt/50Hz 1500 rpm
	-	930262	Motor 37.0 kW 380-420 Volt/50Hz 1500 rpm
	-	930260	Motor 45.0 kW 380-420 Volt/50Hz 1500 rpm
	-	930260	Motor 55.0 kW 380-420 Volt/50Hz 1500 rpm
2	1	930248	Expanding bushing
	-	930265	" "
	-	930266	" "
	-	930262	" "
3	4	940060	Washer, hardened
	-	940017	" "
	-	940352	" "
4	4	940737	Hex head screw
	-	940254	" "
	-	940482	" "
5	3	930260	Drive-belt
6	1	2-45865	Motor mounting bracket
	-	2-45217	" "
	-	2-45444	" "
7	1	3-45455	Pulley, cutter
8	1	4-45191	Washer, shaft end
9	1	4-45192	Washer, locking shaft end
10	2	4-45221	Distance
11	4	4-45248	Washer
12	2	4-45220	Washer
13	2	940914	T-slots nut M20
14	4	940365	Screw M20
15	2	940819	Screw SHS
16	2	950563	Eye bolt M20
17	2	940572	Nut M20
18	4	940313	Washer
19	2	940186	Nut, locking M20
20	1	930261	Pulley, motor
21	1	940399	Hex head screw
22	1	940033	Hex head screw
23	1	950031	Key, R28x16x140

NOTE: Transmission with more alternative motors are available, contact Conair

## 8.5 Transmission 60Hz

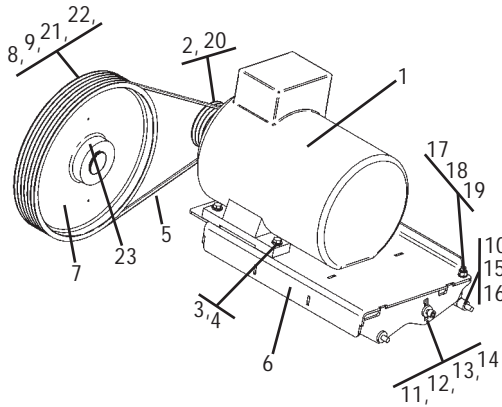

Pos	Qty.						Art. no.	Description
								Transmission 18.5 kW 60Hz
								Transmission 22.0 kW 60Hz
								Transmission 30.0 kW 60Hz
								Transmission 37.0 kW 60Hz
								Transmission 45.0 kW 60Hz
								Transmission 55.0 kW 60Hz
1	1	-	-	-	-	-	992840	Motor 18.5 kW 200-220 Volt/60Hz 1800 rpm
	1	-	-	-	-	-	910019	- " - 18.5 kW 440-480 Volt/60Hz 1800 rpm
	1	-	-	-	-	-	992868	- " - 18.5 kW 380 Volt/60Hz 1800 rpm
	-	1	-	-	-	-	992739	- " - 22.0 kW 200-220 Volt/60Hz 1800 rpm
	-	1	-	-	-	-	911217	- " - 22.0 kW 440-480 Volt/60Hz 1800 rpm
	-	1	-	-	-	-	992869	- " - 22.0 kW 380 Volt/60Hz 1800 rpm
	-	-	1	-	-	-	993162	- " - 30.0 kW 200-220 Volt/60Hz 1800 rpm
	-	-	1	-	-	-	910021	- " - 30.0 kW 440-480 Volt/60Hz 1800 rpm
	-	-	1	-	-	-	993164	- " - 30.0 kW 380 Volt/60Hz 1800 rpm
	-	-	-	1	-	-	992496	- " - 37.0 kW 200-220 Volt/60Hz 1800 rpm
	-	-	-	1	-	-	910133	- " - 37.0 kW 440-480 Volt/60Hz 1800 rpm
	-	-	-	1	-	-	992371	- " - 37.0 kW 380 Volt/60Hz 1800 rpm
	-	-	-	-	1	-	993163	- " - 45.0 kW 200-220 Volt/60Hz 1800 rpm
	-	-	-	-	1	-	910106	- " - 45.0 kW 440-480 Volt/60Hz 1800 rpm
	-	-	-	-	1	-	992358	- " - 45.0 kW 380 Volt/60Hz 1800 rpm
	-	-	-	-	-	1	993161	- " - 55.0 kW 200-220 Volt/60Hz 1800 rpm
	-	-	-	-	-	1	910113	- " - 55.0 kW 440-480 Volt/60Hz 1800 rpm
	-	-	-	-	-	1	993165	- " - 55.0 kW 380 Volt/60Hz 1800 rpm
2	1	1	-	-	-	-	930248	Expanding bushing
	-	-	1	-	-	-	930265	- " -
	-	-	-	1	1	-	930266	- " -
	-	-	-	-	-	1	930262	- " -
3	4	4	-	-	-	-	940060	Washer, hardened
	-	-	4	4	4	-	940017	- " -
	-	-	-	-	-	4	940352	- " -
4	4	4	-	-	-	-	940737	Hex head screw
	-	-	4	4	4	-	940254	- " -
	-	-	-	-	-	4	940482	- " -
5	3	3	5	5	6	6	930260	Drive-belt
6	1	1	1	1	1	1	2-45865	Motor mounting bracket 1824
	1	1	1	1	1	1	2-45217	- " - 1836
	1	1	1	1	1	1	2-45444	- " - 1848
7	1	1	1	1	1	1	3-45455	Pulley, cutter
8	1	1	1	1	1	1	4-45191	Washer, shaft end
9	1	1	1	1	1	1	4-45192	Washer, locking shaft end
10	2	2	2	2	2	2	4-45221	Distance
11	4	4	4	4	4	4	4-45248	Washer
12	2	2	2	2	2	2	4-45220	Washer
13	2	2	2	2	2	2	940914	T-slots nut M20
14	4	4	4	4	4	4	940365	Screw M20
15	2	2	2	2	2	2	940819	Screw SHS
16	2	2	2	2	2	2	950563	Eye bolt M20
17	2	2	2	2	2	2	940572	Nut M20
18	4	4	4	4	4	4	940313	Washer
19	2	2	2	2	2	2	940186	Nut, locking M20
20	1	1	1	1	1	1	930264	Pulley, motor
21	1	1	1	1	1	1	940399	Hex head screw
22	1	1	1	1	1	1	940033	Hex head screw
23	1	1	1	1	1	1	950031	Key, R28x16x140

**NOTE:** Transmission with more alternative motors are available, contact Conair

## 8.6 Screen and Screen Box

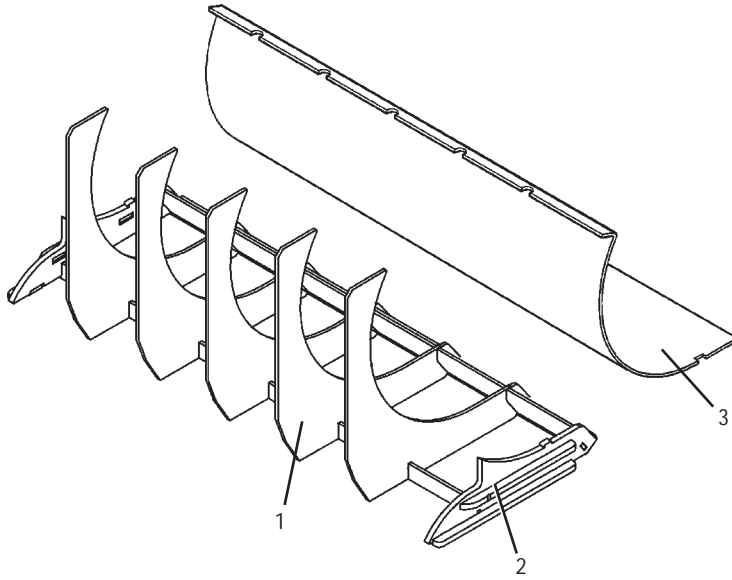

Pos	Qty.			Art. no.	Description
				3-45020	Screen box 1824
				3-45040	Screen box 1836
				3-45056	Screen box 1848
1	1	-	-	1-45692	Screen box
	-	1	-	1-45154	- " -
	-	-	1	1-45427	- " -
2	2	2	2	950646	Sprung bolt M10
3	1	-	-	2-45646	Screen
	-	1	-	2-45647	- " -
	-	-	1	2-45674	- " -
	1	-	-	2-45767	Screen hardened
	-	1	-	2-45768	- " -
	-	-	1	2-45769	- " -

**NOTE:** Specify art no. and required hole diameter Ø 5, 6, 10,12, 17 or 25 mm.

## 8.7 Granule Bin

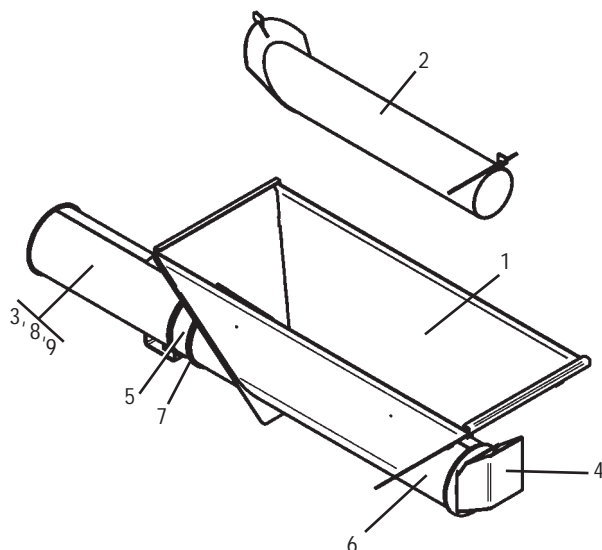

Pos	Qty.			Art. no.	Description
	┌			3-45083	Discharge granule bin OK160 1824
		┌		3-45042	Discharge granule bin OK160 1836
			┌	3-45058	Discharge granule bin OK160 1848
1	1	-	-	1-45776	Granule bin OK160
	-	1	-	1-45160	- " -
	-	-	1	1-45437	- " -
2	-	1	-	3-45879	Distribution plate
	-	-	1	3-45877	- " -
3	1	1	1	3-45193	Flange, outlet OK160
4	1	1	1	2-45441	Air inlet granule bin OK160
5	1	1	1	920098	Pipe OK160 x 60
6	1	1	1	920203	Bolt coupling OK160
7	2	2	2	920107	Quick coupling OK160
8	1	1	1	940660	Hex head screw
9	1	1	1	940031	Washer BRB

## 8.8 Hopper front - soundproofing, soundproofing and extraction fan

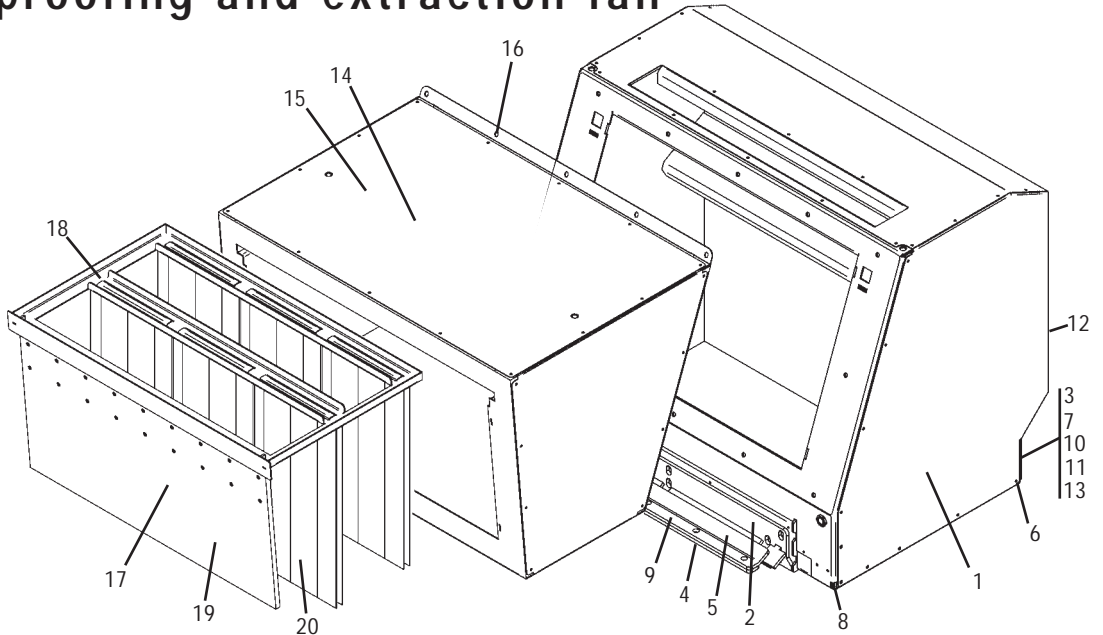

Pos	Qty.	Art. no.	Description	Pos	Qty.	Art. no.	Description
		3-45013	Hopper front 600 x 450	14		3-45014	Inlet, complete 600 x 450
		3-45033	Hopper front 900 x 450			3-45034	Inlet, complete 900 x 450
		3-45049	Hopper front 1200 x 450			3-45050	Inlet, complete 1200 x 450
1	1	2-45880	Hopper front	15	1	2-18362	Inlet 600 x 450
	-	2-45250	- " -		-	2-45267	- " - 900 x 450
	-	2-45321	- " -		-	2-45342	- " - 1200 x 450
2	1	3-45896	Sealing, front	16	5	940052	Screw M10
	-	3-45235	- " -	17		3-45016	Flap, complete 600 x 450
	-	3-45320	- " -			3-45036	Flap, complete 900 x 450
3	1	3-45890	Sealing, back			3-45052	Flap, complete 1200 x 450
	-	2-45239	- " -	18	1	2-45930	Flap holder 604 x 454
	-	3-45317	- " -		-	2-45280	- " - 904 x 454
4	1	3-45895	Ruler, front, lower		-	1-45358	- " - 1204 x 454
	-	3-45231	- " -	19	1	2-45933	Flap 618 x 470
	-	3-45318	- " -		-	2-45283	- " - 918 x 470
5	1	3-45894	Ruler, front, upper		-	2-45354	- " - 1218 x 470
	-	3-45232	- " -	20	4	3-45786	Flap double
	-	3-45319	- " -		6		
6	2	4-45294	Sealing, front piece				
7	2	4-45249	Shaft				
8	8	940250	Screw M5				
9	14	940177	Screw M16				
10	2	940032	Screw M8				
11	4	940444	Screw M8				
12	3	940074	Screw M16				
13	2	940585	Washer, hardened				

## 8.9 Inlet, sound trap, flap - Soundproofing, conveyor, and extraction fan

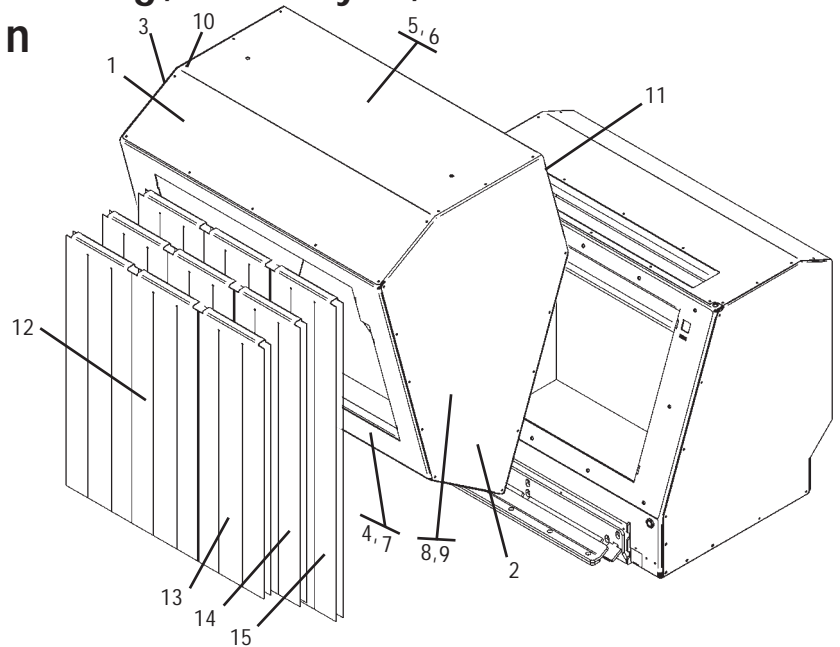

Pos	Qty.		Art. no.	Description	
			3-45015	Inlet -KB, complete 600	1824
			3-45035	Inlet -KB, complete 900	1836
			3-45051	Inlet -KB, complete 1200	1848
1	1	-	2-45924	Inlet -KB 600	
	-	1	2-45300	- " - 900	
	-	-	2-45535	- " - 1200	
2	1	1	2-45296	Side plate, left	
3	1	1	2-45297	Side plate, right	
4	1	-	3-45923	Bottom plate	
	-	1	3-45298	- " -	
	-	-	3-45543	- " -	
5	1	-	3-45922	Top plate	
	-	1	3-45299	- " -	
	-	-	3-45542	- " -	
6	1	-	3-45921	Absorber, inlet, upper	
	-	1	3-45396	- " -	
	-	-	3-45541	- " -	
7	1	-	3-45920	Absorber, inlet, lower	
	-	1	3-45398	- " -	
	-	-	3-45540	- " -	
8	2	2	3-45399	Absorber, inlet, side, inner	
9	2	2	3-45414	Absorber, inlet, side, outer	
10	54	54	940915	Screw 6x12	
11	12	12	940052	Screw M10	
12			3-45017	Flap, complete	1824 Soundproofing and conveyor
			3-45037	Flap, complete	1836 Soundproofing and conveyor
			3-45053	Flap, complete	1848 Soundproofing and conveyor
13	2	3	2-45790	Flap	310 x 1000
14	2	3	2-45791	Flap	310 x 1100
15	2	3	2-45793	Flap	310 x 1300

## 8.10 Outfeed, blower F25

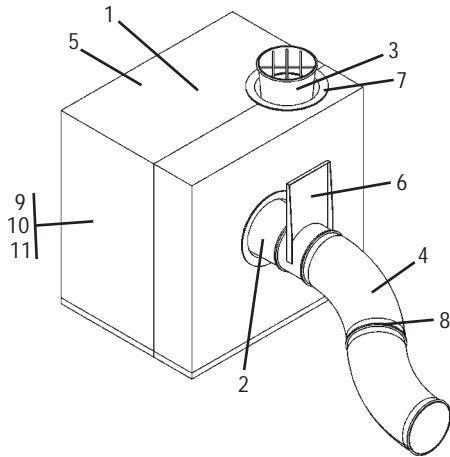

Pos	Qty.	Art. no.	Description
		3-29249	Blower F25, complete
1	1	2-06036	Sound hood
2	1	2-08679	Flanged pipe, inlet OK160
3	1	2-08684	Flanged pipe, outlet OK160
4	2	4-17781	Pipe bend OK160 45°
5	1	920210	Blower F25
6	1	920197	Shutter OK160
7	2	970153	Sealing ring
8	4	920107	Quick-action ring
9	12	940022	Hex. head screw M12
10	16	940155	Washer BRB
11	12	940207	Nut M12

## 8.11 Outfeed, Blower F40 and HZS 18/45

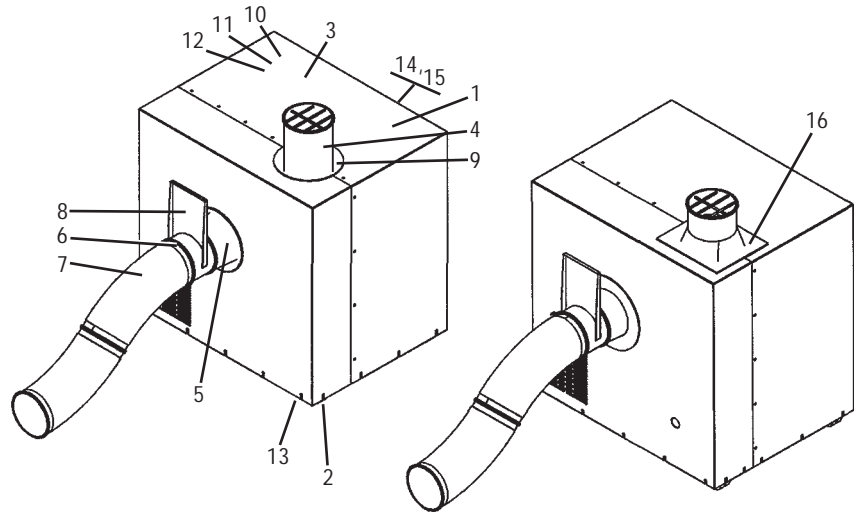

Pos	Qty.	Art. no.	Description	Note
1	1	3-40638	Blower F40	
	-	3-40315	Blower HZS 18/45	
	-	3-08841	Sound hood	
2	-	3-07483	- " -	
	4	950427	Castor	
	1	920883	Blower F40, 5,5 kW	200-220 V 50 Hz
	-	920884	- " -	200-220 V 60 Hz
	-	991343	- " -	380-420 V 60 Hz
	-	991032	Blower HZS 18/45, 5,5 kW	380 V 60 Hz
	-	920190	- " -	380-420 V 50 Hz
	-	992264	- " -	440-480 V 60 Hz
	-	91655	Blower HZS 18/45, 7,5 kW	380 V 60 Hz
	-	991459	- " -	380-420 V 50 Hz
4	-	991458	- " -	440-480 V 60 Hz
	1	3-08683	Flanged pipe, outlet	
-	1	3-18754	- " -	
5	1	3-08677	Flanged pipe, inlet	
6	4	920107	Quick-action ring	
7	2	4-17781	Pipe bend 45o	
8	1	920197	Shutter	
9	2	970153	Sealing ring	
10	16	940207	Nut, M12	
11	16	940022	Hex head screw, M12	
12	16	940155	Washer	
13	31	940552	Hex head screw, M6	
14	1	911032	Connector, 6-pol	
15	1	911006	Connector, 6-pol	
16	-	970255	Sealing	

## 8.12 Body

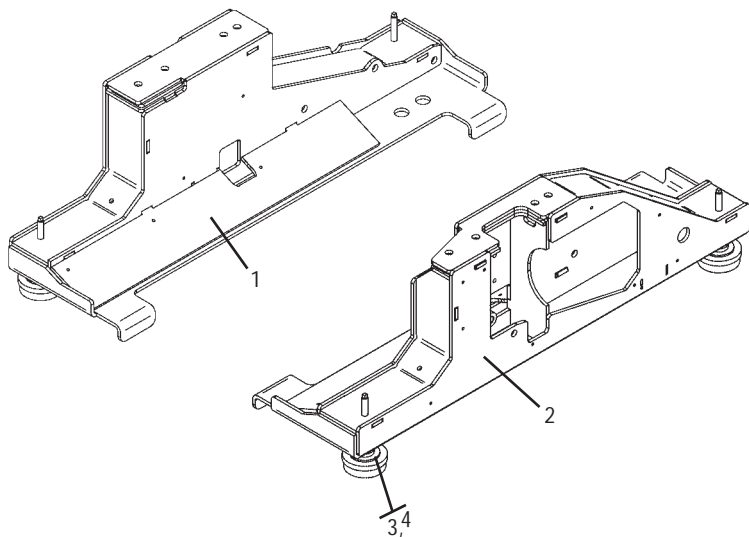

Pos	Qty.				Art. no.	Description
	┌	┐	└	┘		
					3-45024	Body 1824
					3-45024	Body 1836
					3-45024	Body 1848
1	1	1	1		2-45200	Stand, left
2	1	1	1		2-45208	Stand, right
3	12	12	12		4-45248	Washer
4	4	4	4		950308	Machine shoe D 120 M16

## 8.13 Jack

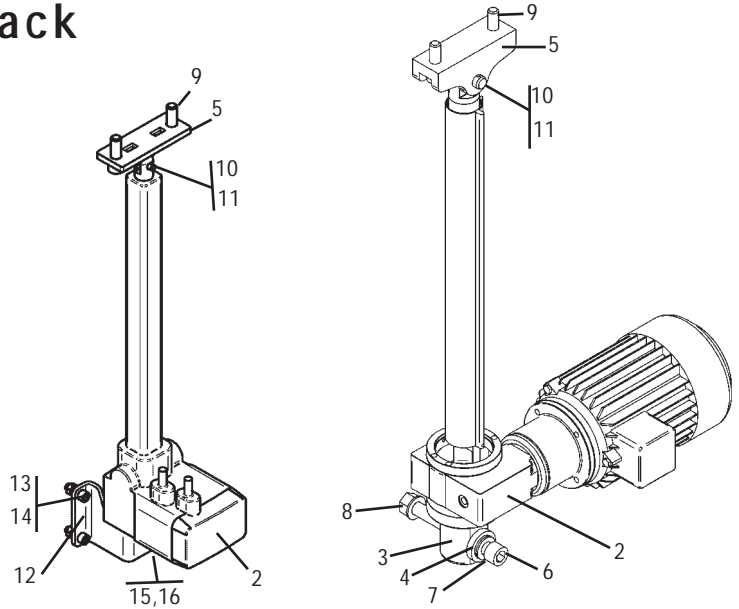

Pos	Qty.						Art. no.	Description
1	1	1	1	-	-	-	3-45062	1824 soundproofing, soundproofing and extraction fan
	-	-	-	1	1	1	3-45018	1836 soundproofing, soundproofing and extraction fan
2	1	1	1	-	-	-	993152	1848 soundproofing, soundproofing and extraction fan
	-	-	-	1	1	1	993040	1824 soundproofing and conveyor, soundproofing, conveyor and extraction fan
3	-	-	-	2	2	2	4-45230	1836 soundproofing and conveyor, soundproofing, conveyor and extraction fan
4	-	-	-	1	1	1	4-45248	1848 soundproofing and conveyor, soundproofing, conveyor and extraction fan
5	1	1	1	-	-	-	3-45784	Jack complete
	-	-	-	1	1	1	3-45614	Jack 5000 N
6	-	-	-	1	1	1	940941	Jack 15000 N
7	-	-	-	3	3	3	940313	Bushing, rubber
8	-	-	-	1	1	1	940079	Washer
9	2	2	2	-	-	-	940674	Swing bracket
	-	-	-	2	2	2	940425	- " -
10	2	2	2	-	-	-	940945	Socket head screw M20
	-	-	-	1	1	1	940913	Washer
11	2	2	2	-	-	-	940946	Nut M20
	-	-	-	1	1	1	940927	Screw M16
12	1	1	1	-	-	-	3-45226	- " -
13	4	4	4	-	-	-	940845	Bracket
14	4	4	4	-	-	-	940030	Screw M10
15	2	2	2	-	-	-	960057	Nut M10
16	2	2	2	-	-	-	940155	Slide bearing
								Washer

## 8.14 Cutter Lock

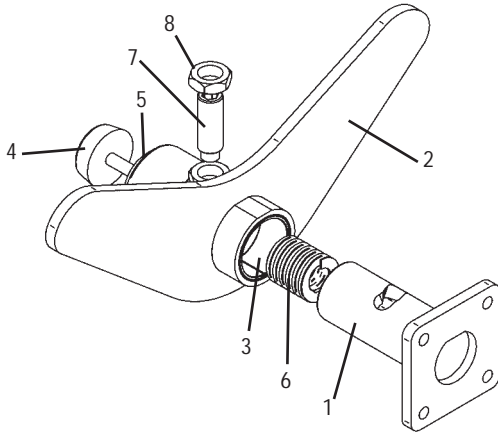

Pos	Qty.	Art. no.	Description
		2-45446	Rotor locking 1824
		2-45446	Rotor locking 1836
		2-45446	Rotor locking 1848
1	1	3-45452	Rotor locking fixed part
2	1	2-45453	Rotor locking movable part
3	2	960221	Slide bearing
4	1	950687	Damper
5	1	940030	Nut M10
6	1	950685	Compression spring
7	1	940862	Grub screw M20
8	1	940392	Nut M20

# 8.15 Enclosure

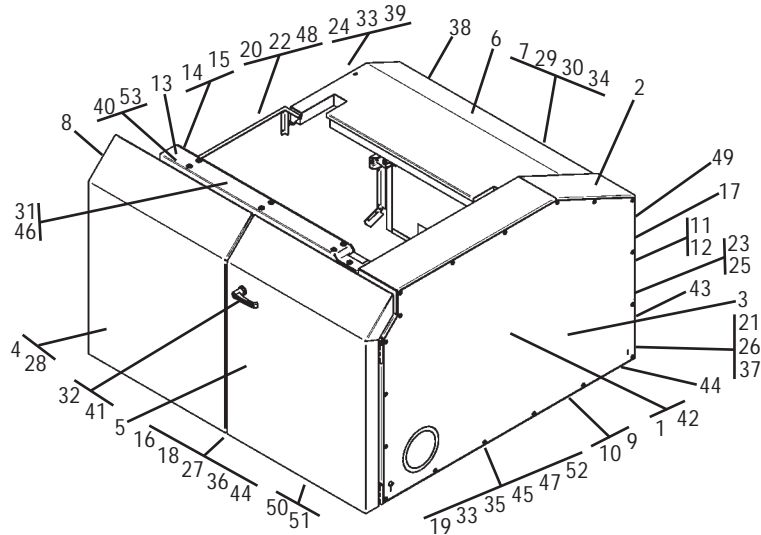

Pos	Qty.	Art. no.	Description	Pos	Qty.	Art. no.	Description
		3-45025	1824 Enclosure			3-45025	1824 Enclosure
		3-45043	1836 Enclosure			3-45043	1836 Enclosure
		3-45059	1848 Enclosure			3-45059	1848 Enclosure
1	1	2-45361	Cover, right	22	1	3-45375	Holder, list back left
2	1	3-45569	Cover, right upper	23	1	3-45376	Holder, list back right
3	1	3-45364	Enclosure, cover right	24	1	3-45510	Holder, list back lower left
4	1	1-45622	Door, left	25	1	3-45511	Holder, list back lower right
	-	1-45366	- " -	26	2	3-45471	Absorbent 80, Enclosure
	-	1-45387	- " -	27	1	3-45509	Absorbent, door
5	1	1-45369	Door, right	28	1	3-45629	Absorbent, door, left
6	1	1-45625	Cover, back middle		-	3-45668	- " -
	-	1-45377	- " -	29	1	3-45631	Absorbent, cover back middle
	-	1-45383	- " -		-	3-45563	- " -
7	1	2-45627	Cover, back lower		-	3-45670	- " -
	-	2-45548	- " -	30	1	3-45630	Absorbent, cover back lower
	-	2-45666	- " -		-	3-45564	- " -
8	1	2-45628	Back plate, door left		-	3-45669	- " -
	-	2-45367	- " -	31	1	3-45633	Absorbent, distance, hopper
	-	2-45386	- " -	32	1	950689	Lock, door
9	1	2-45370	Back plate, door right	33	4	950585	Hinge 100*75*8
10	1	1-45795	Bottom plate	34	1	970156	List 427010
	-	1-45372	- " -	35	33	940885	Screw SHS
	-	1-45384	- " -	36	6	940070	Screw M8
11	2	3-45378	Bracket, cover back middle	37	1	940729	Screw M8
12	4	3-45547	Bracket, cover back lower	38	4	940196	Screw SHS
13	1	3-45975	Distance, front hopper	39	4	940791	Screw SHS
	-	3-45529	- " -	40	7	940801	Screw M6
	-	3-45656	- " -	41	1	940126	Screw M8
14	1	3-45977	Distance, middle hopper	42	14	940444	Screw M8
	-	3-45530	- " -	43	6	940806	Screw M8
	-	3-45659	- " -	44	42	940750	Screw 4.2
15	1	3-45978	Distance, back hopper	45	5	940077	Screw M6
	-	3-45371	- " -	46	14	940552	Screw M6
	-	3-45385	- " -	47	8	940955	Screw SHS
16	1	4-45687	Distance, L=104 cover	48	40	940623	Pop-riwet
17	1	4-45339	Distance, D=20/10x104 cover	49	4	940016	Nut M8
18	1	3-45341	Distance, lock door	50	3	950550	Nut blind rivet M6
19	2	3-45389	Distance, hinge door	51	26	950551	Nut blind rivet M8
20	1	3-45373	Holder, list front left	52	2	940027	Nut M6
21	1	3-45374	Holder, list front right	53	7	940860	Washer, body

## 8.16 Electrical Components

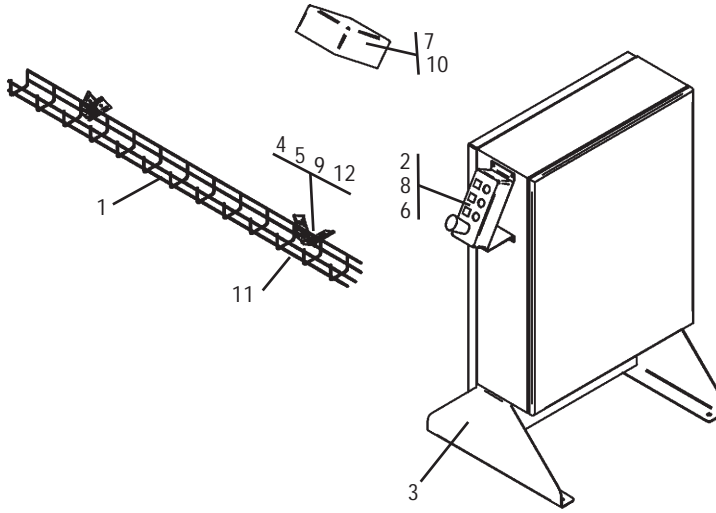

Pos	Qty.			Art. no.	Description
				3-45026	Electrical components 1824
				3-45076	Electrical components 1836
				3-45077	Electrical components 1848
1	1	-	-	3-45501	Wire duct way 75 x 55, 948
	-	1	-	3-45502	Wire duct way 75 x 55, 1248
	-	-	1	3-45503	Wire duct way 75 x 55, 1548
2	1	1	1	3-20942	Bracket
3	1	1	1	2-42136	Stand
4	2	2	2	911466	Wire duct way, angle
5	2	2	2	911464	Wire duct way, joint
6	1	1	1	911502	Operating box
7	1	1	1		Junction box
8	4	4	4	940552	Screw M6
9	2	2	2	940444	Screw M8
10	4	4	4	940443	Screw M8
11	2	2	2	940667	Coach bolt
12	2	2	2	940203	Nut

## 8.17 Security

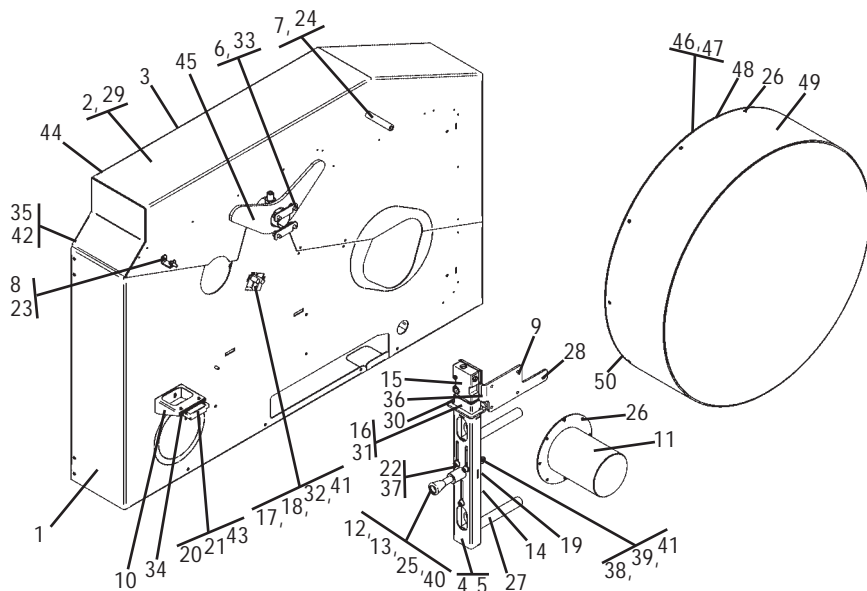

Pos	Qty.	Art. no.	Description	Pos	Qty.	Art. no.	Description
		3-45078	Safety, noise encapsulated machine			3-45078	Safety, noise encapsulated machine
		3-45023	Safety, unencapsulated machine			3-45023	Safety, unencapsulated machine
		3-45075	Safety, unencapsulated w flywheel			3-45075	Safety, unencapsulated w flywheel
1	1	2-45254	Cover	26	8	940032	Screw M8
2	1	3-45473	Cover, left upper	27	2	940918	Screw SHS
3	1	3-45247	Cover, left	28	14	940444	Screw M8
4	2	3-45234	Locking clip	29	18	940885	Socket head screw M8
5	1	3-45810	Cover plate, lock	30	2	940090	Screw M5
6	4	4-45474	Distance	31	2	940926	Screw
7	1	4-45339	Distance	32	3	940898	Screw M10
8	1	4-45340	Distance	33	4	940573	Screw SHS
9	1	3-45813	Bracket, switch	34	4	940547	Screw SHS
10	1	3-45194	Bracket, switch	35	4	940510	Socket head screw M8
11	-	3-45146	Protection, shaft	36	2	940076	Screw M5
12	1	4-45937	Handle	37	6	940031	Washer BRB
13	1	950681	Knob	38	1	940944	Lock washer
14	3	4-45939	Sleeve 20/11-28	39	1	940960	Washer BRB
15	1	993207	Switch, key	40	6	940961	Washer, spring
16	1	911649	Key, switch	41	6	940030	Nut M10
17	1	911758	Sensor, inductive	42	4	940016	Nut M8
18	1	911759	Sensor, inductive	43	4	940315	Nut M4
19	1	950697	Compression spring	44	18	950551	Nut, blind rivet
20	1	911727	Switch magnet	45	1	2-45446	Rotor locking
21	1	911728	Switch magnet	46	-	4-45478	Distance
22	3	940298	Screw M10	47	-	4-45479	Distance
23	2	940070	Screw M8	48	-	3-45459	Flywheel guard, inner
24	3	940729	Screw M8	49	-	3-45462	Flywheel guard, outer
25	1	940200	Screw M8	50	-	940355	Screw M8



## 8.19 Cyclone and Dust Filter

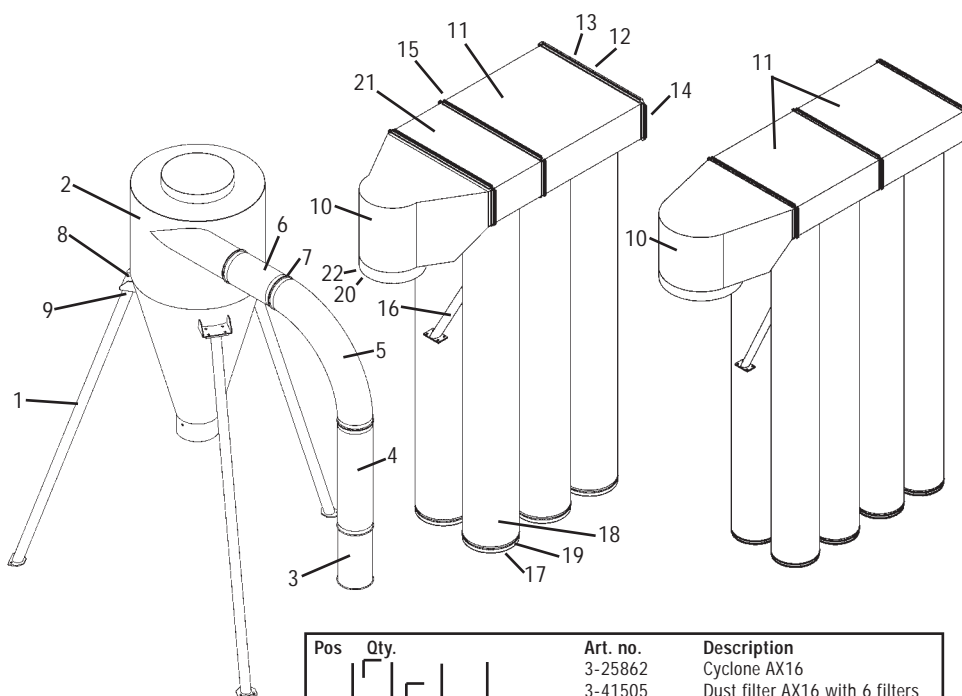

Pos	Qty.			Art. no.	Description
				3-25862	Cyclone AX16
				3-41505	Dust filter AX16 with 6 filters
				3-36427	Cyclone AX20
				3-41507	Dust filter AX20 with 8 filters
1	3	-		4-00448	Leg
			3	4-00493	- " -
2	1	-		3-03037	Cyclone OK160
			1	2-03101	- " -
3	1	-	1	920105	Pipe, telescopic
4	1	-		4-11766	Pipe OK160, 600
			1	4-11765	Pipe OK160, 970
5	1	-	1	4-11769	Pipe bend OK160, 90o
6	1	-	1	4-11767	Pipe OK160, 300
7	5	-	5	920107	Quick action ring
8	12	-	12	940028	Hex head screw M10
9	12	-	12	940030	Nut M10
10	-	1	-	3-04539	Connection part
			1	3-04537	- " -
11	-	1	-	3-04538	Filter box part
12	-	1	-	3-04517	Side plate, filter
13	-	6	-	4-07633	Rail, assembly
14	-	6	-	4-07634	Rail, assembly
15	-	1	-	3-04209	Bracket, support, filter box
16	-	1	-	4-04212	Support, filter box
			1	4-04208	- " -
17	-	6	-	3-04220	Bottom plate, filter box
18	-	6	-	920332	Filter, D=300
			8	920333	- " -
19	-	12	-	3-10592	Tightening strap, D=300
20	-	1	-	970040	Clip list
21	-	1	-	3-07623	Filter box part
22	-	12	-	940431	Self tapping screw

## 8.20 Tools and Fixtures

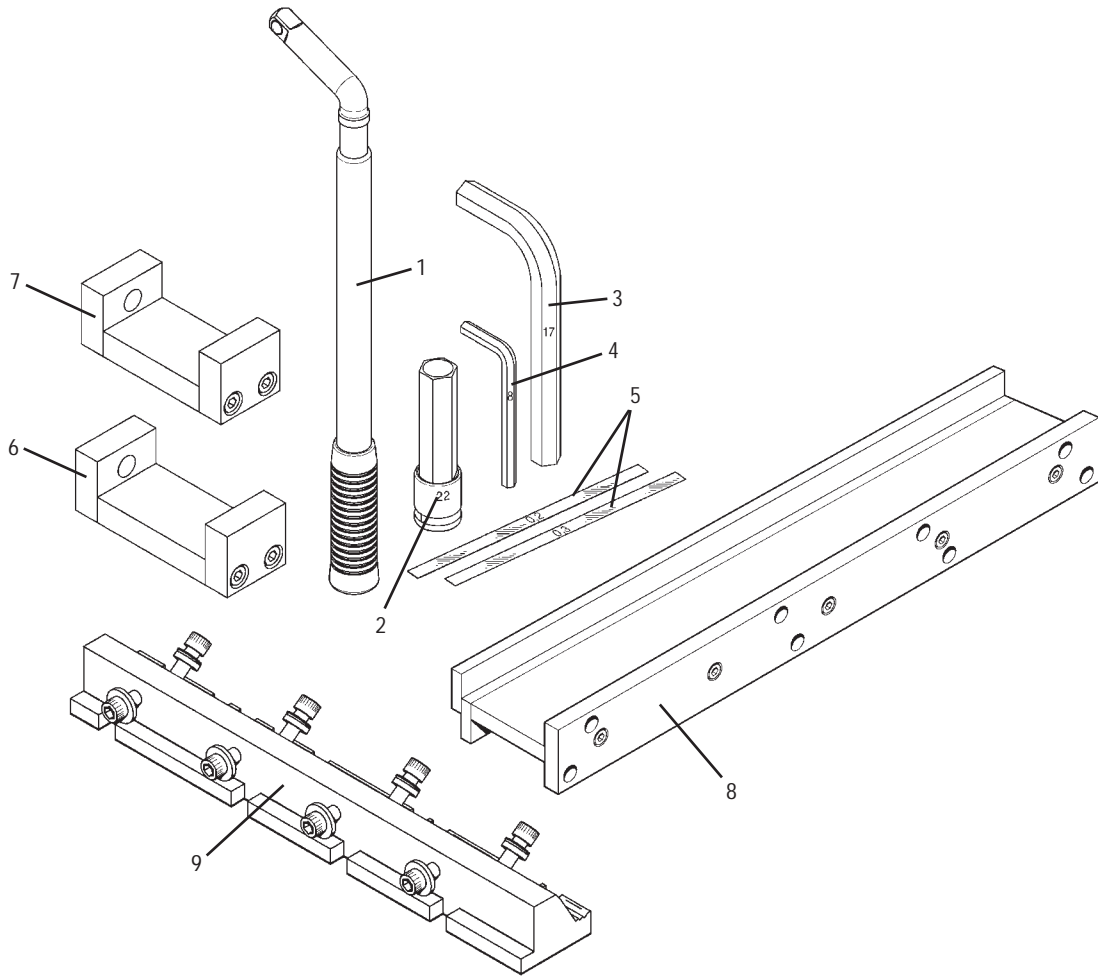

Pos	Qty.	Art. no.	Description
1	1	970294	Tool, telescopic 1/2"
2	1	4-45497	Bits 1/2", 22 mm
3	1	970297	Hex wrench 17 mm
4	1	970296	Hex wrench 8 mm
5	1		Feeler gauge 0.20 mm
	1		Feeler gauge 0.30 mm
6	1	3-45470	Knife pre-set fixture for rotating knives
7	1	3-45469	Knife pre-set fixture for fixed knives
8	1	3-45082	Knife pre-set fixture for fixed and rotating knives
9	1	3-45652	Grinding fixture for knives



# Wiring Diagram

---

9.1 Current sensing relay . . . . .	9-3
– Connection . . . . .	9-3
– Setting . . . . .	9-3
Default setting for this granulator . . . . .	9-4
– Example . . . . .	9-5

# 9. Wiring Diagram

Never change or modify the basic electrical settings of the granulator, without first obtaining permission from the Conair Head Office.

If the granulator settings are changed, the machine can be seriously damaged.

All Warranties and Conair's Product Liability will be void, if the basic settings of the granulator are changed.

All electrical maintenance and service work must be done by trained and competent personnel!

Electrical installation must only be done by a competent electrician!

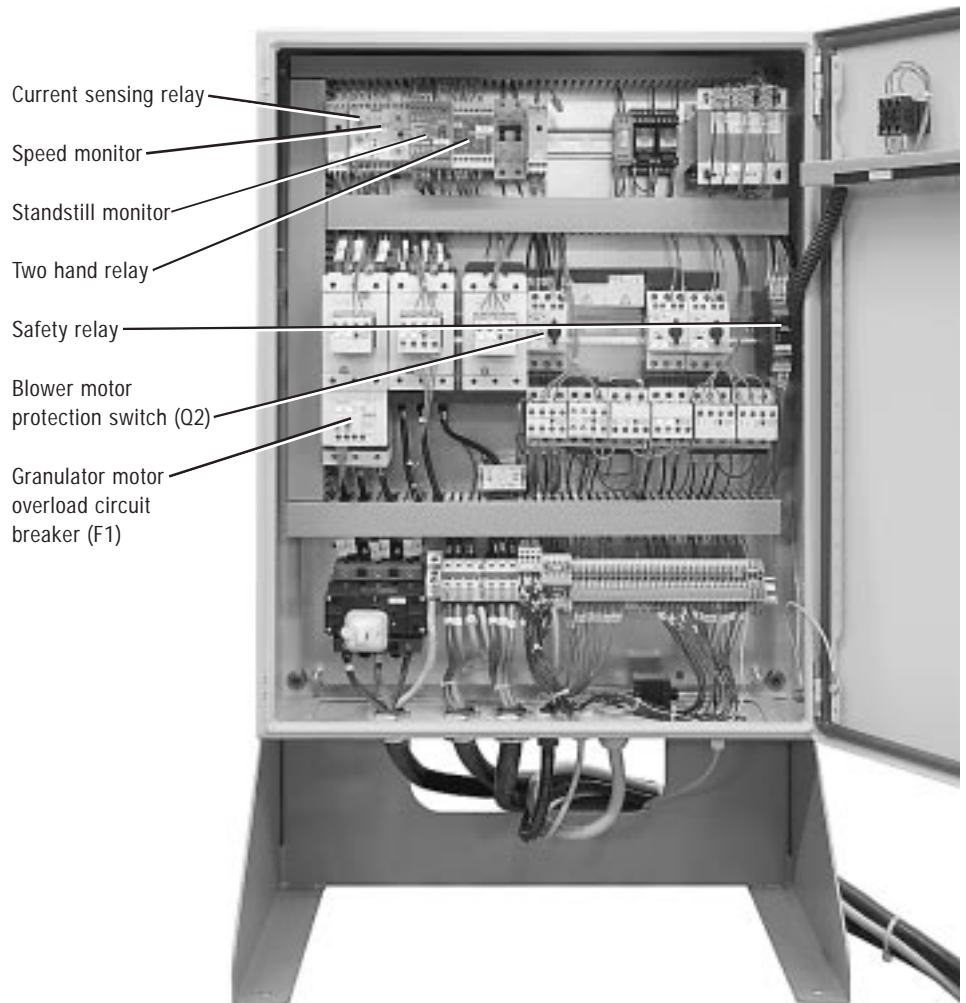

# 9.1 Current sensing relay

The granulator can be equipped with an optional current sensing relay to control the feed equipment.

The current sensing relay detects the granulator motor current consumption and can temporarily stop accessories such as conveyors, roller feeders etc to avoid putting further material into the hopper, when the granulator is running under heavy loading.

The relay stops and re-starts accessory equipment automatically, without re-setting.

### Relay functions and normal settings:

- T1 – Reaction time, time delay which prevents the relay from opening during an intermittent high loading (0.1 - 3 sec.).  
Default reaction time is 3.0 seconds.
- T2 – Time delay on starting, which prevents the relay from opening when the granulator is started (0.1 - 10 sec.).  
The default start delay is 0.1 seconds.
- A – Limit value, adjustable between 0 - 100 %.  
Default setting depends on the current transformer size.  
Check the current transformer size and then check the default setting for this granulator.
- B – Hysteresis, adjustable between 5 - 50% of the set limit.  
Default hysteresis is 20 %.
- C – Yellow LED, relay status indication.
  - Lit when everything is OK, i.e. when the current is below the limit value.
  - Goes out if there is an alarm.
- D – Green LED, indication for control current OK.

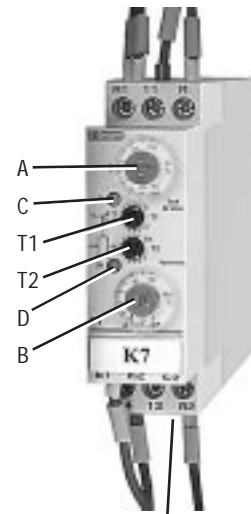

Function choice with or without memory

### Connection

The current sensing relay is connected in series with the granulator motor via a current transformer. The transformer is connected between M and E1/E2/E3 depending on the secondary current.

(For transformers with transformation to 1 A, this is connected to E1.)

- Set function choice
- with or without memory.
  - with under-current or excess current.

### Setting

The limit value is set with “A” for the upper % setting. The current value at which you want the relay to open. Note that the percentage knob depends on current transformer size and the measurement input used, E1, E2 or E3.

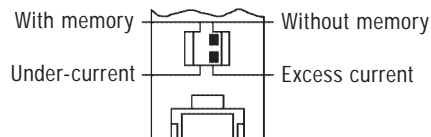
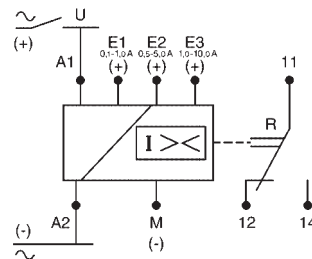

## 9.1 Current sensing relay (continued)

A simple way to find the correct limit value for your granulator is to have the granulator motor in normal operation, then turn the knob back from 100% until the relay drops. Then turn the knob forwards until the limit is just above this level.

The lower % setting, “B”, is used to set the hysteresis-in level. The level after alarm when the relay should re-start the feed equipment/conveyor. If the hysteresis knob is set at 20%, the relay will re-start the feed equipment when the current has gone down to the limit value plus the hysteresis value of 20%.

“T1” is a time delay, which determines the time that the granulator motor can exceed the set limit value before the relay drops.

“T2” is a time delay, which is only activated when the granulator starts. This time delay prevents the relay from dropping when the granulator is started and when the current usually exceeds the set limit value for the relay.

Function setting with or without memory. When you use the “With memory” setting, the relay does not re-start the feed equipment of the granulator when the current has fallen to the limit value plus the hysteresis value. The relay memory setting must be re-set manually first.

The default setting of this function choice is “Without memory”.

Function selection, with under-current or excess current. We measure the current used by the granulator, so the selector should be in the “Excess current” position.

### Default setting for this granulator:

Granulator motor, rated current: .....  $\sqrt{3}$  ..... = A

(recommended fuse in mains min 1,5 x granulator motor rated current)

Current transformer: ..... /1A

Time delay reaction time T1: 3.0 sec.  other value: .....

Time delay at start T2: 0.1 sec.  other value: .....

Limit values: % ..... = .....A

Hysteresis: % ..... = .....A

Function choice:  with memory  without memory  under-current

excess current

## 9.1 Current sensing relay (continued)

### Example

The granulator is equipped with a current sensing relay to control a conveyor.

A motor of 55 kW has a rated current of about 97 A.

The current in one phase will be approx 97 A/ i.e. 56 A per phase. \*)

### Relay setting:

Motor size 97 A/ = 56 A per phase

T1 – Set reaction time is 3.0 seconds.

T2 – Set start delay is 0.1 second.

A – Limit value 56 %.

B – Hysteresis 20 %.

C – Yellow LED is lit, current is below the limit value.

D – Green LED is lit.

Function selection in mode without memory.

The current transformer size is 100/1A.

The current transformer is connected to E1 (1 A).

On a current sensing relay with a transformation ratio of 100/1, the limit value “A” should be set to 56 % corresponding 56 A (100 A = 100 %).

The current sensing relay detects the current consumption of the granulator motor and stops the conveyor, when the granulator motor consumption exceeds 56 A for 3 seconds, to prevent further material from being fed into the hopper.

The Yellow LED flashes when the current exceeds the set limit value, and goes out when the conveyor stops. The Green LED is lit.

The relay re-starts the conveyor automatically when the granulator motor consumption has fallen 20 % below 56 A, i.e. to 45 A without a time delay.

The Yellow and Green LEDs are lit.

\*) If only one electric wire is passing through the center hole in the transformer: Count with the current in one phase.

If a several electric wires are passing through the center hole in the transformer: Count with the whole motor current.

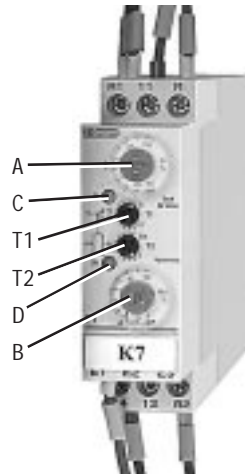



# Layout

---

10.1 Layout . . . . . 10-2

# 10. Layout

## CW Granulator, hopper front

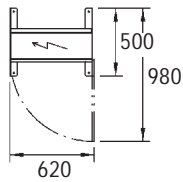
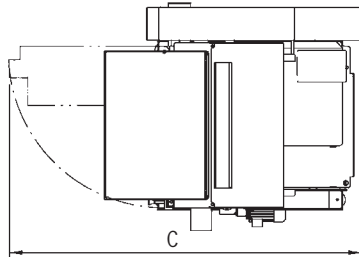
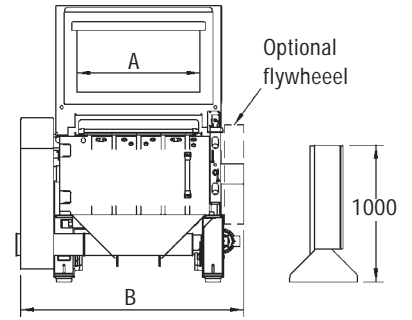
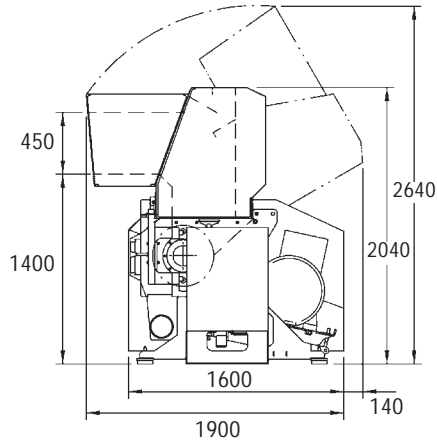

Model	1824	1836	1848
A	600	900	1200
B	1340	1640	1940
C	2300	2600	2900

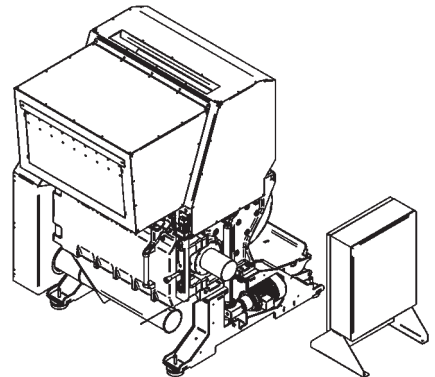

**CW Series with soundproofing**

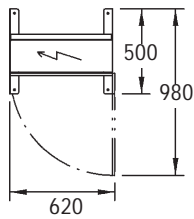
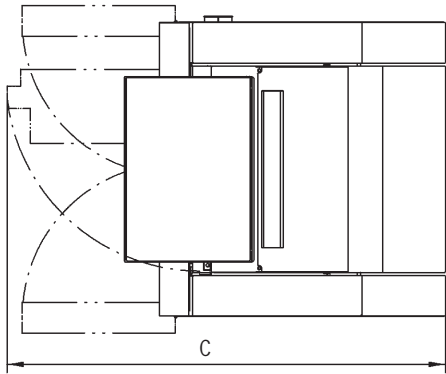
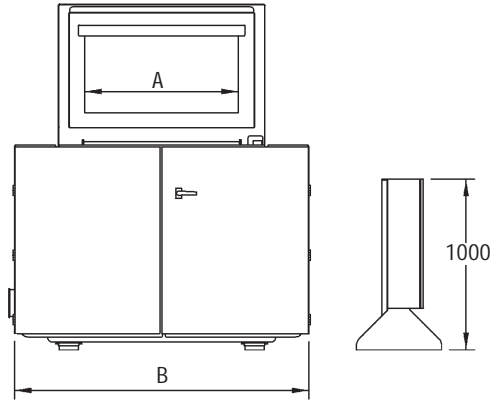
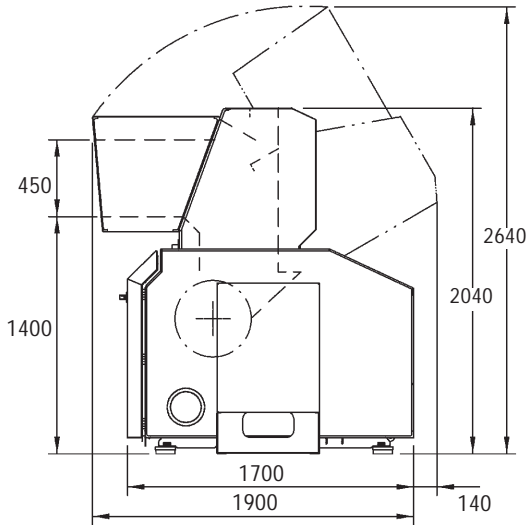

Model	1824	1836	1848
A	600	900	1200
B	1440	1740	2040
C	2300	2600	2900

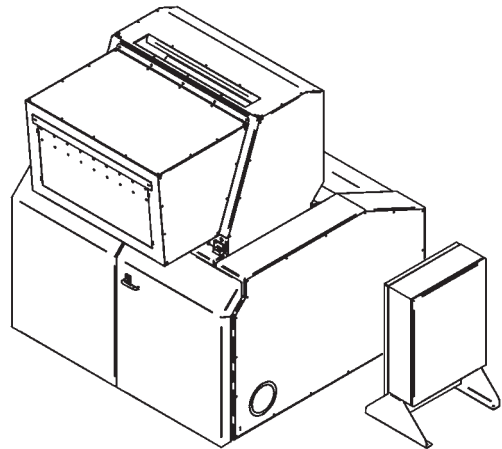

### CW Series with soundproofing and conveyor

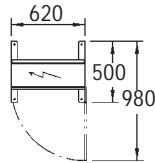
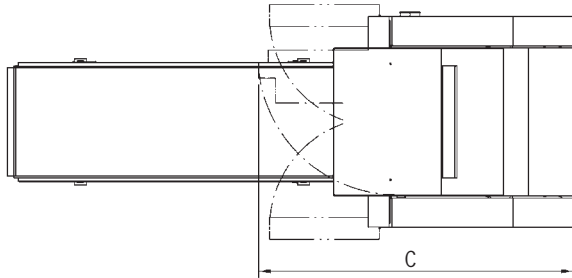
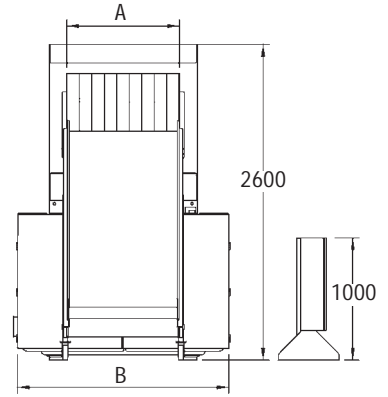
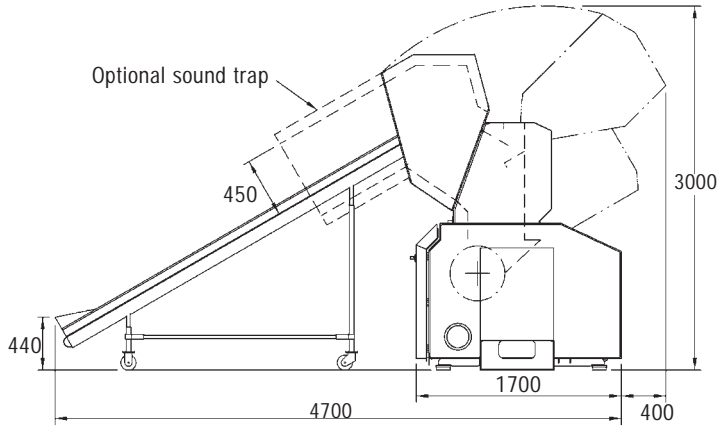

Model	1824	1836	1848
A	600	900	1200
B	1440	1740	2040
C	2300	2600	2900

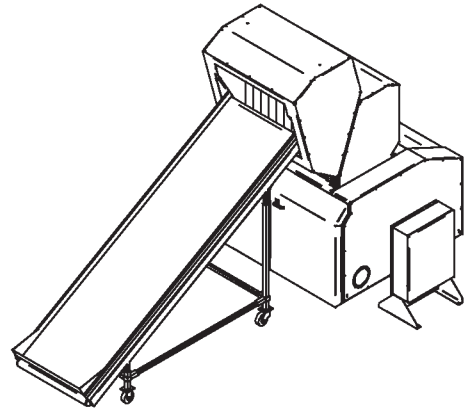

# Options

---

11.1 Knife pre-setting fixture . . . . .	11-3
11.2 Cutter housing, changing rear side of the cutter housing . . . . .	11-5
11.3 Friction clutch, cutter belt pulley, flywheel . . . . .	11-6
11.4 Blower F25 and F40, safety, installation, maintenance . . . . .	11-7
11.5 Speed monitor . . . . .	11-9
11.6 Paddle monitor . . . . .	11-10
– Setting the paddle monitor sensitivity . . . . .	11-10
11.7 Band conveyor . . . . .	11-11
– Safety, installation, electrical connection, start	11-11
– Maintenance, fault finding . . . . .	11-12
– Spare parts for band conveyor . . . . .	11-14

# Ordering spare parts

Only use original Conair spare parts when replacing machinery components.

When ordering spare parts, please specify:

- Machine type/designation, on the machine's rating plate.
- Serial number, on the machine's rating plate.
- Part number, from this list of spare parts.
- Number of components.

# 11.1 Knife pre-setting fixture

Your CW Conair granulator reflects a high technical level, and is manufactured with such a precision that all knives in the granulator can be pre-set before they are installed in the cutter housing.

Two pre-setting fixtures of the compact model type, for pre-setting of fixed and rotating knives are delivered in the granulator tool bag.

A bigger pre-setting fixture with higher precision is available as an option, art.no. 3-45082.

The pre-setting fixture makes the knife installation simpler and quicker.

The pre-setting fixture is calibrated against the fixed knife positions in the granulator.

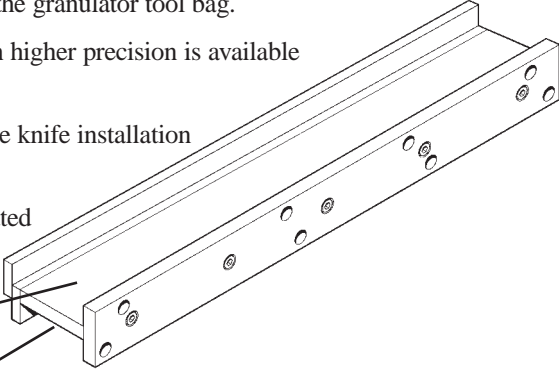

Setting position for rotating knives  
Setting position for fixed knives

## Rotating knives

The rotating knives, have fixed set knife positions in the cutter.

The bigger pre-setting fixture makes it easy to pre-set the rotating knives to a knife clearance of 0.20 mm, before the knives are installed in the knife positions on the cutter.

## Fixed knives

The fixed knives, have fixed set knife positions in the cutter house/cutter house door.

The bigger pre-setting fixture makes it easy to pre-set the fixed knives to a knife clearance of 0.20 mm, before the knives are installed in the cutter house/cutter house door.

(continued)

# 11.1 Knife pre-setting fixture

(continued)

## Pre-setting of knives

An 8 mm hex wrench and a 0.20 mm feeler gauge, to pre-set all knives in the granulator, is in the granulator tool bag.

**NOTE:** The knives must be sharpened before pre-setting.

- 1** Screw the adjustment screws in somewhat (into the knife) on the knife which is to be pre-set.
- 2** Place the knife in correct position on the knife fixture and so that the knife adjusting screws are accessible through the holes in the fixture.  
The knife should lie with the knife edge backward and upwards.
- 3** Put an 0.20 mm feeler gauge between the the edge of the knife and the rear of the fixture.
- 4** Use the hex wrench (8 mm) unscrew the adjustment screws until the feeler gauge begins to bind.
- 5** Then the pre-setting is completed and the knife can be installed in the granulator.

**NOTE:** All the knife adjusting screws should be set!

## 11.2 Cutter housing, changing rear side of the cutter housing

Conair's CW granulator is one of the world's most advanced granulators.

The type of cutter housing can subsequently be adapted to new applications by changing the rear side of the cutter housing.

This involves precision work that can and must be done by Conair's service department, with the object of maintaining accuracy and tolerances (cutter, knives, knife positions, presetting sizes, etc).

Please contact Conair's local agent or Conair's Corporate office.

### Types of cutter housings

#### The basic version of cutter house

Cutter with 3 rotating knives. The basic version of cutter house.

The cutter housing is equipped with 2 fixed counter knives.

- Fixed counter knife no. 1 and no. 2.

Space is available for two additional fixed counter knives which gives a higher capacity.

- Fixed counter knife no. 4 and no. 5.5.

#### The cutter house intended for bulky items

Cutter with 3 rotating knives.

The cutter house intended for bulky items.

The cutter housing is equipped with 2 fixed counter knives.

- Fixed counter knife no. 2 and no. 5.

Space is available for one additional fixed counter knife which gives a higher capacity.

- Fixed counter knife no. 4.

#### The cutter house intended for precutting

Cutter with 3 rotating knives. The cutter house intended for precutting function.

The cutter housing is equipped with 2 fixed counter knives.

- Fixed counter knife no. 2 and no. 3.

Space is available for two additional fixed counter knives which gives a higher capacity.

- Fixed counter knife no. 4 and no. 5.

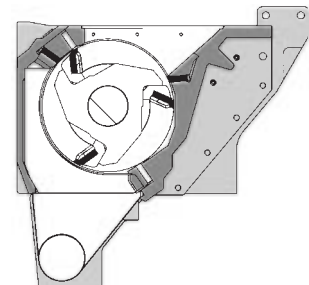
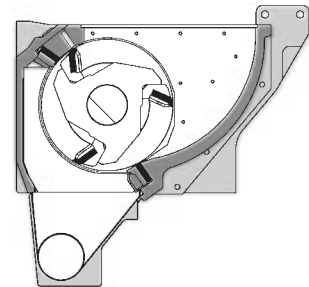
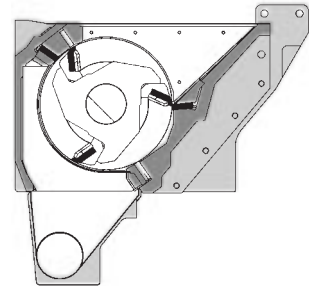

# 11.3 Friction clutch, cutter belt pulley, flywheel

The cutter belt pulley and flywheel can be equipped with a friction clutch to minimize damage in the event of stoppage in the granulator. When the machine is delivered, the clutch is set to transmit torque corresponding to normal granulating.

Check the friction clutch every 6 months.

- Remove the protective plate which covers the cutter belt pulley or the flywheel.
- Cut off the twined locking wires which pair-wise locks the setting screws.
- Check the tightening torque of the screws in the friction clutch. (hex wrench 17 mm).

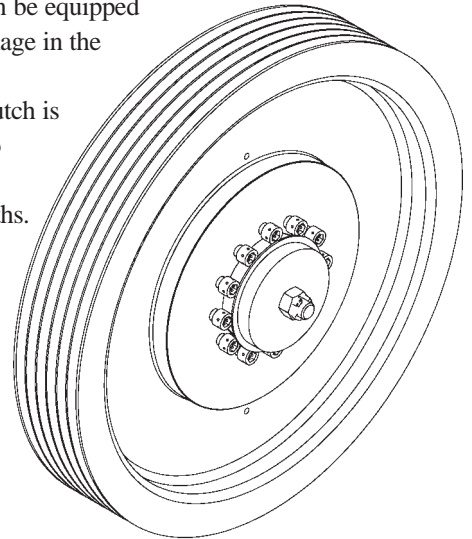

The torque is not dependent on the size of the motor:

The tightening torque of the screws should be max. . . . . 20 Nm.

Lock the screw settings pair-wise.

Lock by interconnecting two screws pair-wise with a steel wire. Twine the steel wire so that it locks the setting of the screws.



**NOTE:** The tightening torque of the friction clutch must never be increased.

If the clutch slips during normal granulating, even if the tightening torque is correct, the clutch discs may need to be degreased or replaced.

Contact your local Conair distributor or Conair corporate office.

## 11.4 Blower F25 and F40

Conair's blowers F25 and F40 are intended for dust and material conveying.



**NOTE:** The temperature of the conveyed material must never exceed

It is not permitted to use the blowers in surroundings where the temperature exceeds 40°C or goes below -20°C.

It is not permitted to rebuilt, modify or use the blowers in explosive atmospheres. F25 and F40 are available with or without soundproofing.

### Safety

The following safety advice must be observed, to avoid personal injury, damage to peripheral equipment and to the fan itself.

It is not permitted to use the blowers in humid environments or unprotected outdoors.



**WARNING!** F25 and F40 have very high suction power.

Ensure that no large pieces of plastic are drawn into the blower. If large pieces of plastic are drawn into the blower they could seriously damage the impeller and blower housing.

Objects and clothing can easily be sucked into the blower inlet and cause personal injury. Blowers F25 and F40 must therefore never be used with an unprotected inlet opening.



**WARNING!** F25 and F40 produce a very powerful stream of air at the discharge opening.

**NOTE:** The stream of air from the discharge opening is very powerful. Granulate and objects which have been sucked in to the blower, will be thrown out at very high speed and can cause personal injury. Never put the hand directly in front of the blower discharge opening.



### Electrical connection

Electrical connection must only be done by a competent electrician.



### Sound level

The sound pressure level is not the same at different blower speeds. If a fan is used without a sound-damping housing, ear protection should be used to prevent hearing damage.

(continued)

## 11.4 Blower F25 and F40 (continued)

### **Installation**

Check that the fan does not have any transport damage before installation and commissioning.

### **Arrangements and mounting**

The blower can be mounted horizontally or vertically.

It is not permitted to use the blowers in humid environments or unprotected outdoors.

Before the blower is taken into service, check that the blower impeller rotates freely and does not have any imbalance. Then install the blower so that it can not vibrate.

Install a protective grating on the exhaust opening.

Make sure that the electrical motor is provided with sufficient ventilation, the maximum permissible ambient temperature is 40°C.

### **Maintenance**

The blower has enclosed grooved ball bearings lubricated for life and can not be lubricated later on.

For any repair or maintenance please contact the local Conair distributor or the Conair corporate office.

### **Spare parts**

*See section 8.*

# 11.5 Speed monitor

The machine can as an option be equipped with a speed monitor.

The speed monitor is set at the factory and does not normally require re-adjustment. The speed monitor triggers and stops the granulator if the rotor does not reach the correct speed after starting, or if the speed drops to a level too low for granulating.

The sensors to the speed monitor are placed on the cutter belt pulley

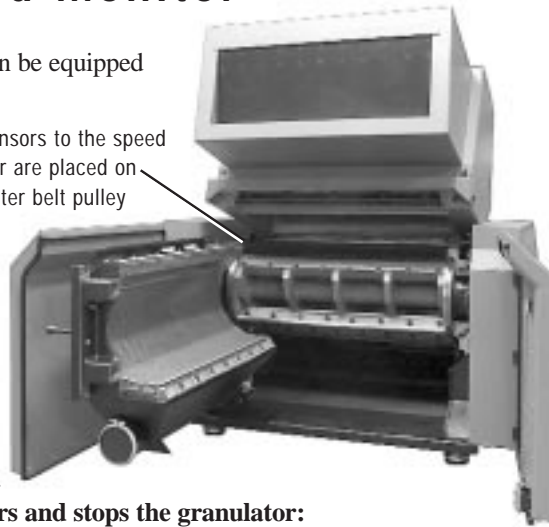

**If the speed monitor triggers and stops the granulator:**

Check that the drive belts do not slip.

The speed monitor has not reset.

Check that there is no material left in the granulator before re-starting.

Clean and re-start the granulator.



Speed monitor relay in electrical cabinet.

## 11.6 Paddle monitor

The granulator can be optionally equipped with one or several paddle monitors.

The paddle monitor is a level monitor which senses the granule level in the granule bin or outlet pipe stub.



The paddle monitor senses and stops the granulator, or the granulator feed equipment, such as the band conveyor, roll feed etc. when the level in the granule bin/outlet pipe stub rises too high.

The paddle monitor stops and re-starts the granulator or the optional feed equipment without needing to be re-set.



**NOTE:** The paddle monitor must never be used as handle during opening or emptying of the granule bin. Seriously risk of electrical burn injuries!

### Setting the paddle monitor sensitivity

The sensitivity of the paddle monitor is adjustable.

- Open, remove the textile tape and unscrew the cover over the microswitches in the paddle monitor.
- Adjust the position of the torsion spring.



Use a needle-nosed pliers to change the spring position.

The normal setting of the torsion spring is the 2nd hole from the left.

Reducing the paddle monitor sensitivity:

(The paddle monitor breaks the connection more slowly)

- Turn the torsion spring to the left.

Increasing the paddle monitor sensitivity:

(The paddle monitor breaks the connection more quickly)

- Turn the torsion spring to the right.

- Fit and tighten the cover over the paddle monitor microswitches.



**NOTE:** Then lock the cover using textile tape.

## 11.7 Band conveyor

The band conveyor is designed for transporting plastic waste. The conveyor is constructed from steel beam. The frame pieces are assembled with cross sections and screw.

The conveyor can be fitted with a metal detector.

Instructions for the metal detector, see separate instruction manual.

### Safety

When performing any work with the band conveyor, both the circuit-breaker and the main switch must be “Off”. Alternatively, the connector must be pulled out of the power point on the granulator’s electrical cabinet!

The conveyor is designed for plastic waste. Do not use the conveyor for tasks other than it is intended for.

Nobody should be on the conveyor or step on it during operation.

If the conveyor has stopped due to an error, or if the emergency stop has been pressed, it must not be re-started until the cause has been established and the appropriate action has been taken.

Mobile conveyors must always be transported in a lowered position.



**Warning!** When using the conveyor belt with carriers: Be careful not to let the carriers catch your foot, arm, or article of clothing.



**NOTE:** Be careful when moving or transporting the conveyor.

### Band conveyor with sound trap

The sound trap makes that the center of gravity for the conveyor come high up. The conveyor can easily fall or tip over when being moved or lifted.

### Installation

When installing, adjust so that the band conveyor is balanced diagonally.

If the floor of the installation site is very uneven, it should be made even before installation.

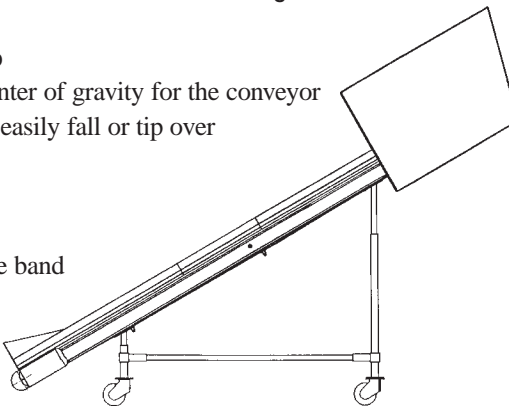

(continued)

## 11.7 Band conveyor (continued)

### Electrical connection

**The band conveyor should be connected up by an authorized electrician.**

Connect the band conveyor to the electrical cabinet with a connector.

Alternatively, connect the cable to electrical cabinet according to the markings and the granulator's wiring diagram.

Switch on the main switch on the electrical cabinet. Press the start button and check that the belt moves in the right direction.

If the belt moves in the wrong direction.

Shift the two phases in connection to the contactor for the band conveyor in the electrical cabinet. Alternatively, shift the two phases in the connection to the connector.

### Starting

When the band conveyor is started for the first time, the belt's position on the rollers should be checked. The belt must not move obliquely.

### If the belt moves obliquely.

To gain access to the adjusting screws, remove the hoods by the turning roller.

When the belt moves obliquely. Screw only one adjusting screw at a time.

Only screw a 1/4 turn.

Wait and let the belt move for a few minutes.

Check, adjust, wait, and check again until the belt moves straight.

### Belt tension.

The conveyor belt's length has 1% tolerance. Never tension the belt's adjusting screws with a greater tightening torque than 5 Nm.

When the belt has been adjusted. Stop the band conveyor and fit the hoods.

### Maintenance

During all maintenance work on the band conveyor, both the circuit-breaker and the main switch must be "Off". Alternatively, the connector must be pulled out of the power point!

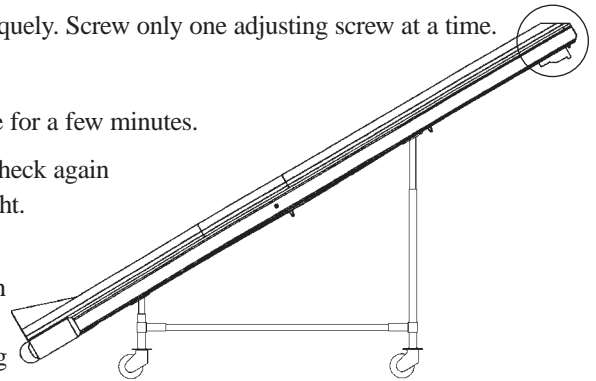

(continued)

## 11.7 Band conveyor (continued)

Regularly check the conveyor belt's wear and its position on the rollers.

The belt must not move obliquely! Adjust as necessary according to the instructions under "Starting - If the belt moves obliquely", see previous section.

Clean the belt using a light cleaning agent. Do not use any sharp objects, strong cleaning agents or chemicals which can damage the belt.

### Fault-finding

#### The band conveyor does not start

Check the band conveyor motor protection switch .

The band conveyor motor has an motor protection switch, Q3, in the electrical cabinet box, which trips if you jam or overload the conveyor belt.

If the motor protection switch has switched "Off", the switch will be in position "0".

Reset – set the switch to position "1".

Check that there is no material left on the conveyor belt before re-starting.

Also check the granulator's wiring diagram, supplements and deviations may be applicable.



## Spare parts for band conveyor

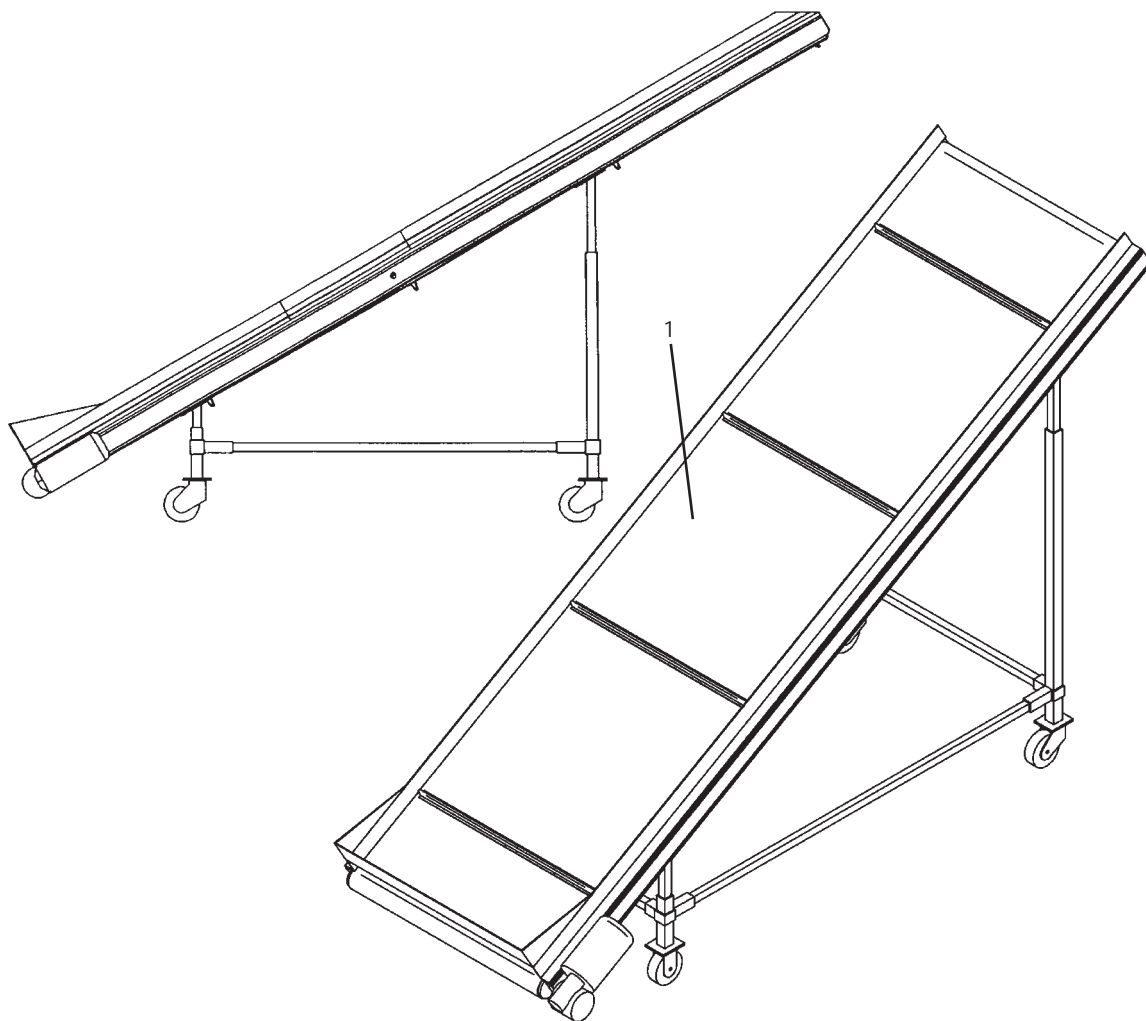

Pos	Qty.	Art. no.	Description	
1	1	3-45028	Band conveyor 1824, complete	
		3-45044	Band conveyor 1836, complete	
		3-45060	Band conveyor 1848, complete	
		2-	Band conveyor	
2	4	1	Band conveyor	
		1	Band conveyor	
		4	9-92814	Wheel, turnable
		4		

# Transport, Lifting, and Storage

---

- Lift and transport to place of use . . . . . 12-4
- Storage . . . . . 12-5

# 12. Transport, lifting and storage

The machine should be transported by trained personnel.

The machine is delivered packed in protective plastic foil, fixed to a transport pallet with straps.

Unpacking and receiving inspection

- Check that the machine has not been damaged during transport.



**NOTE:** Report any damage to the forwarding agent.

- Do not unpack the machine before it has been transported to where it is going to be used.
- Check with the delivery note that the delivery is complete.



### **Lift and transport to place of use by means of a fork-lift truck**

The machine should be lifted and handled by means of a fork-lift truck which has extended long forks.



**NOTE:** The machine must not be lifted by using lifting straps!

The machine weighs incl. packaging, approx. 3250 - 4000 kg, *see also "Technical specification", section 2.*

Space requirements, *see Layout, section 10.*

The hopper and doors must be properly closed before lift and transport.



### **OBSERVE! The weight point of the machine is unequal!**

The front side of the machine (door side) is normally heavier than the rear side. The machine is normally lifted from front side, but depending on the granulator:

- motor size, manufacture and weight
- type of hopper
- possible optional equipment

the weight of the machine and distribution of weight varies.

On delivery shows signs on the machine from which side and how the machine can be lifted.



**IMPORTANT!** Two yellow signs shows the positions for the truck forks during lift.



**NOTE:** Then shows at least one additional sign, the shortest permissible fork length and the weight of the machine.

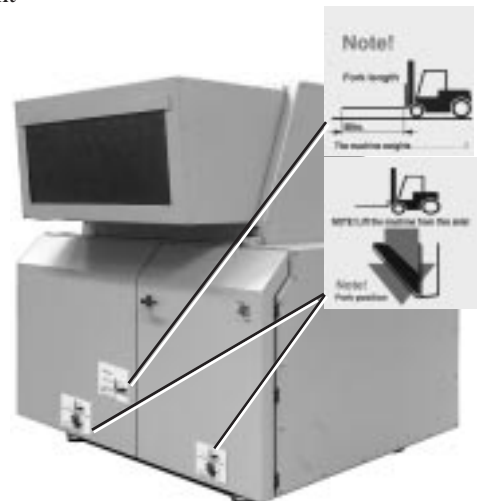

(continued)

# 12. Transport, lifting and storage

(continued)

Lift the machine with care and in the way shown in this section.

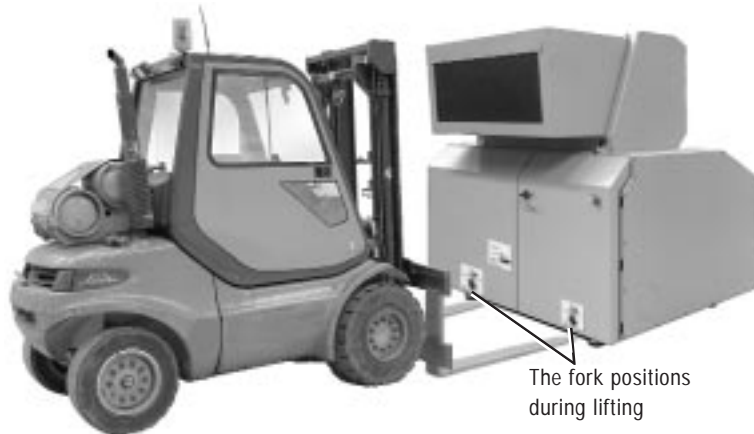

## **Machine with uninstalled hopper or inlet part**

The granulator can because of way of transport be delivered with the hopper or front inlet part uninstalled.

On top of the hopper or top of the front inlet part there is in this case eyebolts fitted which are intended for lifting with lifting straps.

Use these eyebolts only to lift the hopper or the front inlet part.



**NOTE:** A complete machine must never be lifted by using the eyebolts and lifting straps on the hopper or front inlet part!

## **Positioning and installation in place of use**

*See Installation, section 5.*

(continued)

# 12. Transport, lifting and storage

(continued)

Lift and transport to place of use by help of a crane/traversing crane  
The machine should be lifted and handled by means of a crane or a traversing crane.



**NOTE:** Use profile beams and lifting straps!



**NOTE:** Make sure that each one lifting beam can carry the machine weights without to be deformed.

The machine weighs incl. packaging, approx. 3250 - 4000 kg, *see also "Technical specification", section 2.*

The hopper and doors must be properly closed before lift and transport.



**OBSERVE! The weight point of the machine is unequal!**

The front side of the machine (door side) is normally heavier than the rear side, but depending on the granulator:

- motor size, manufacture and weight
- type of hopper
- possible optional equipment

the weight of the machine and distribution of weight varies.

Fit two profile beams under the frame of the machine.



**IMPORTANT!** Place the profile beams to the positions where the yellow signs shows the positions for the truck forks during lift.

Fit a upper lifting beam and lifting straps on the way shown in the illustration. Balance the weight point of the granulator.

Lift the machine with great care and make sure that nobody stays underneath or close to the machine during lifting.

(continued)

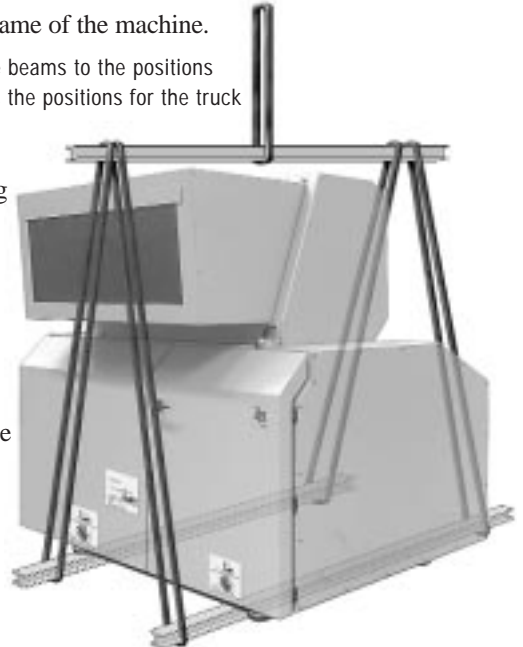

# 12. Transport, lifting and storage

(continued)

## **Storage**

The machine is packed for transport to the place where it is to be used.

On delivery it is protected with Castrol DWX 22 anti-rust oil.

## **Long-term storage/Conservation**

- Store the machine in a room with a stable, dry temperature.
- Treat the unpainted surfaces of the machine with rust preventer, such as Castrol DWX 22.

DWX 22 will protect the machine up to 12 months.

Alternatively, DWX 160 will provide protection for 24 - 36 months.



# Service and maintenance schedule

---

Machine data . . . . .	13-2
- Installation . . . . .	13-3
- Inspection . . . . .	13-5
Weekly inspection . . . . .	13-5
Monthly inspection . . . . .	13-8
Inspection every 3 month . . . . .	13-10
Inspection every 6 month or 1000 running hours . . . . .	13-12
- Knife changing . . . . .	13-14
- Malfunctions . . . . .	13-15
- Notes . . . . .	13-16

# 13. Service and maintenance schedule

Read the instruction manual before maintenance and service. All maintenance and service must be done by trained personnel.

If you have any questions, please contact the local Conair distributor or the Conair head office.

Local distributor: .....  
.....  
.....

### Head office:

Conair  
One Conair Drive  
Pittsburgh, PA 15202  
Phone. 412-312-6000  
Fax. 412-312-6227

### Machine data

Machine type: .....Serial number: .....  
Year of manufacture: 20 .....  
Motor: .....V. ....Hz. ....kW  
Wiring diagram: .....

### Safety, maintenance and service

Contact person responsible for granulator safety, maintenance and service

Name: .....	Phone: .....
Name: .....	Phone: .....
Name: .....	Phone: .....
Name: .....	Phone: .....
Name: .....	Phone: .....
Name: .....	Phone: .....
Name: .....	Phone: .....
Name: .....	Phone: .....
Name: .....	Phone: .....
Name: .....	Phone: .....
Name: .....	Phone: .....

**Installation**

- The safety measure 600 mm behind the granulator hopper, when the hopper is opened checked.
- The cutter housing stands horizontally and the stands all machine shoes takes up load.
- The granulator have been cleaned from anti-rust oil.
- The screws tightening torque to the fixed knife no. 1 (rear) have been checked ..... Nm.
- The screws tightening torque to the fixed knife no. 2 (front) have been checked ..... Nm.
- The screws tightening torque to the rotating knives have been checked ..... Nm.
- The screws tightening torque to the fixed knife no. 3 have been checked ..... Nm.
- The screws tightening torque to the fixed knife no. 4 have been checked ..... Nm.
- The screws tightening torque to the fixed knife no. 5 have been checked ..... Nm.
- Knife clearance checked, knife clearance at the knives outer sides ..... and the knives center .....
- The screws tightening torque which fastening the hopper have been checked.
- Oil level in worm gear to the roll feeder checked.

**Electrical connection**

- Voltage connection checked ..... Voltage. .... Hz.
  - Size of fuse controlled 1-phase ..... A. 3-phase 3 x ..... A.
  - The phase sequence of the mains checked.
  - The granulator have been connected to right-hand field phase sequence.
  - At least one emergency stop knob is always within reach of the operator inside the working range of the granulator.
- The granulator have been on installation fitted with additional ..... emergency stops.
- The rotation direction of the granulator motor have been checked.
  - The rotation direction of the blower motor have been checked.
  - The direction of the band conveyer have been checked.
  - Band conveyer, the band position on rollers have been checked.
  - The direction of the roll feeder have been checked.
  - Optional equipment, direction, function and connection have been checked.

**The machine have been installed as per section 5 in this instruction manual by:**

Date: ... / ... .20 ... Name: .....

Responsible and qualified electrician: Name: .....

**Two hours after first start**

- The screws tightening torque to the fixed knife no. 1 (rear) have been re-checked . . . . .Nm.
- The screws tightening torque to the fixed knife no. 2 (front) have been re-checked . . . . .Nm.
- The screws tightening torque to the rotating knives have been re-checked . . . . .Nm.
- The screws tightening torque to the fixed knife no. 3 have been re-checked . . . . .Nm.
- The screws tightening torque to the fixed knife no. 4 have been checked . . . . .Nm.
- The screws tightening torque to the fixed knife no. 5 have been checked . . . . .Nm.
- Knife clearance re-checked, knife clearance at the knives outer sides . . . . . and the knives center. . . . .
- The screws tightening torque which hold the granulator motor to the motor mounting bracket . . . . . Nm.
- The nuts on the adjusting screws which hold the motor mounting bracket setting are counter-tightened checked . . . . . Nm.

Inspection done by Date: . . . / . . . 20 . . . . .Name: . . . . .

**20 - 30 hours after first start**

- The drive belt condition have been checked.
- The drive belt tension have been checked. The drive belt tension have been adjusted.
- The screws tightening torque to the upper bracket of the jack against the hopper checked . . . . .Nm.
- The screws tightening torque to the lower bracket of the jack against the stand checked . . . . .Nm.
- The screws tightening torque to the hopper against the rear hinge checked . . . . .Nm.
- The screws tightening torque to the which holds the locking rule to cutter house door checked . . . . .Nm.
- The cutter housing stands horizontally and the stands all machine shoes takes up load.
- General inspection OK.

Inspection done by Date: . . . / . . . 20 . . . . .Name: . . . . .















# Inspection every 6 months or 1000 hours of operation

Read the Instruction manual section 6.2 Inspection.

**NOTE:** All inspection of the machine must be done by trained personnel.

If there are any notes or faults, contact the person responsible for safety, maintenance and service at once.

Sign checks when they have been approved.

..... / ..... 20 ..... Sign: .....    ..... / ..... 20 ..... Sign: .....    ..... / ..... 20 ..... Sign: .....  
..... / ..... 20 ..... Sign: .....    ..... / ..... 20 ..... Sign: .....    ..... / ..... 20 ..... Sign: .....  
..... / ..... 20 ..... Sign: .....    ..... / ..... 20 ..... Sign: .....    ..... / ..... 20 ..... Sign: .....  
..... / ..... 20 ..... Sign: .....    ..... / ..... 20 ..... Sign: .....    ..... / ..... 20 ..... Sign: .....  
..... / ..... 20 ..... Sign: .....    ..... / ..... 20 ..... Sign: .....    ..... / ..... 20 ..... Sign: .....  
..... / ..... 20 ..... Sign: .....    ..... / ..... 20 ..... Sign: .....    ..... / ..... 20 ..... Sign: .....  
..... / ..... 20 ..... Sign: .....    ..... / ..... 20 ..... Sign: .....    ..... / ..... 20 ..... Sign: .....  
..... / ..... 20 ..... Sign: .....    ..... / ..... 20 ..... Sign: .....    ..... / ..... 20 ..... Sign: .....  
..... / ..... 20 ..... Sign: .....    ..... / ..... 20 ..... Sign: .....    ..... / ..... 20 ..... Sign: .....  
..... / ..... 20 ..... Sign: .....    ..... / ..... 20 ..... Sign: .....    ..... / ..... 20 ..... Sign: .....  
..... / ..... 20 ..... Sign: .....    ..... / ..... 20 ..... Sign: .....    ..... / ..... 20 ..... Sign: .....  
..... / ..... 20 ..... Sign: .....    ..... / ..... 20 ..... Sign: .....    ..... / ..... 20 ..... Sign: .....  
..... / ..... 20 ..... Sign: .....    ..... / ..... 20 ..... Sign: .....    ..... / ..... 20 ..... Sign: .....  
..... / ..... 20 ..... Sign: .....    ..... / ..... 20 ..... Sign: .....    ..... / ..... 20 ..... Sign: .....  
..... / ..... 20 ..... Sign: .....    ..... / ..... 20 ..... Sign: .....    ..... / ..... 20 ..... Sign: .....  
..... / ..... 20 ..... Sign: .....    ..... / ..... 20 ..... Sign: .....    ..... / ..... 20 ..... Sign: .....  
..... / ..... 20 ..... Sign: .....    ..... / ..... 20 ..... Sign: .....    ..... / ..... 20 ..... Sign: .....  
..... / ..... 20 ..... Sign: .....    ..... / ..... 20 ..... Sign: .....    ..... / ..... 20 ..... Sign: .....  
..... / ..... 20 ..... Sign: .....    ..... / ..... 20 ..... Sign: .....    ..... / ..... 20 ..... Sign: .....  
..... / ..... 20 ..... Sign: .....    ..... / ..... 20 ..... Sign: .....    ..... / ..... 20 ..... Sign: .....  
..... / ..... 20 ..... Sign: .....    ..... / ..... 20 ..... Sign: .....    ..... / ..... 20 ..... Sign: .....  
..... / ..... 20 ..... Sign: .....    ..... / ..... 20 ..... Sign: .....    ..... / ..... 20 ..... Sign: .....  
..... / ..... 20 ..... Sign: .....    ..... / ..... 20 ..... Sign: .....    ..... / ..... 20 ..... Sign: .....





# Malfunctions

..... / ..... 20 .....	Fault: .....	.....
	.....	.....
	Action: .....	Sign .....
..... / ..... 20 .....	Fault: .....	.....
	.....	.....
	Action: .....	Sign .....
..... / ..... 20 .....	Fault: .....	.....
	.....	.....
	Action: .....	Sign .....
..... / ..... 20 .....	Fault: .....	.....
	.....	.....
	Action: .....	Sign .....
..... / ..... 20 .....	Fault: .....	.....
	.....	.....
	Action: .....	Sign .....
..... / ..... 20 .....	Fault: .....	.....
	.....	.....
	Action: .....	Sign .....
..... / ..... 20 .....	Fault: .....	.....
	.....	.....
	Action: .....	Sign .....
..... / ..... 20 .....	Fault: .....	.....
	.....	.....
	Action: .....	Sign .....
..... / ..... 20 .....	Fault: .....	.....
	.....	.....
	Action: .....	Sign .....

# Notes

..... / ..... 20 .....	Notes: .....	
	Action: .....	
		..... Sign .....
..... / ..... 20 .....	Notes: .....	
	Action: .....	
		..... Sign .....
..... / ..... 20 .....	Notes: .....	
	Action: .....	
		..... Sign .....
..... / ..... 20 .....	Notes: .....	
	Action: .....	
		..... Sign .....
..... / ..... 20 .....	Notes: .....	
	Action: .....	
		..... Sign .....
..... / ..... 20 .....	Notes: .....	
	Action: .....	
		..... Sign .....
..... / ..... 20 .....	Notes: .....	
	Action: .....	
		..... Sign .....
..... / ..... 20 .....	Notes: .....	
	Action: .....	
		..... Sign .....
..... / ..... 20 .....	Notes: .....	
	Action: .....	
		..... Sign .....

# We're Here to Help

Conair has made the largest investment in customer support in the plastics industry. Our service experts are available to help with any problem you might have installing and operating your equipment. Your Conair sales representative also can help analyze the nature of your problem, assuring that it did not result from misapplication or improper use.

Additional manuals and prints for your Conair equipment may be ordered through the Customer Service or Parts Department for a nominal fee.

## How to Contact Customer Service

To contact Customer Service personnel, call:



From outside the United States, call: 814-437-6861

You can commission Conair service personnel to provide on-site service by contacting the Customer Service Department. Standard rates include an on-site hourly rate, with a one-day minimum plus expenses.

## Before You Call...

**If you do have a problem, please complete the following checklist before calling Conair:**

- Make sure you have all model, serial and parts list numbers for your particular equipment. Service personnel will need this information to assist you.
- Make sure power is supplied to the equipment.
- Make sure that all connectors and wires within and between control systems and related components have been installed correctly.
- Check the troubleshooting guide of this manual for a solution.
- Thoroughly examine the instruction manual(s) for associated equipment, especially controls. Each manual may have its own troubleshooting guide to help you.
- Check that the equipment has been operated as described in this manual.
- Check accompanying schematic drawings for information on special considerations.

## Equipment Guarantee

Conair guarantees the machinery and equipment on this order, for a period as defined in the quotation from date of shipment, against defects in material and workmanship under the normal use and service for which it was recommended (except for parts that are typically replaced after normal usage, such as filters, liner plates, etc.). Conair's guarantee is limited to replacing, at our option, the part or parts determined by us to be defective after examination. The customer assumes the cost of transportation of the part or parts to and from the factory.

## Performance Warranty

Conair warrants that this equipment will perform at or above the ratings stated in specific quotations covering the equipment or as detailed in engineering specifications, provided the equipment is applied, installed, operated and maintained in the recommended manner as outlined in our quotation or specifications.

Should performance not meet warranted levels, Conair at its discretion will exercise one of the following options:

- Inspect the equipment and perform alterations or adjustments to satisfy performance claims. (Charges for such inspections and corrections will be waived unless failure to meet warranty is due to misapplication, improper installation, poor maintenance practices or improper operation.)
- Replace the original equipment with other Conair equipment that will meet original performance claims at no extra cost to the customer.
- Refund the invoiced cost to the customer. Credit is subject to prior notice by the customer at which time a Return Goods Authorization Number (RGA) will be issued by Conair's Service Department. Returned equipment must be well crated and in proper operating condition, including all parts. Returns must be prepaid.

Purchaser must notify Conair in writing of any claim and provide a customer receipt and other evidence that a claim is being made.

## Warranty Limitations

**Except for the Equipment Guarantee and Performance Warranty stated above, Conair disclaims all other warranties with respect to the equipment, express or implied, arising by operation of law, course of dealing, usage of trade or otherwise, including but not limited to the implied warranties of merchantability and fitness for a particular purpose.**